



# THE DATASHEET OF IN-S32GTLS



## Features

- 3.2 x 2.7 SMD LED
- Close responsively to the human eye spectrum ·
- Light to Current, analog output ·
- Good output linearity across wide illumination range ·
- Low sensitivity variation across various light sources ·

## Applications

- Detection of ambient light to control display backlighting
- Mobile devices
- Computing device
- Consumer device
- Automatic residential and commercial management
- Automatic contrast enhancement for electronic signboard
- Ambient light monitoring device for daylight and artificial light

## Description

The IN-S32GTLS is a popular 3.2 x 2.7mm package with versatile design capabilities. It is a PCB type molding style LED which can be used in various applications.

## Recommended Solder Pattern

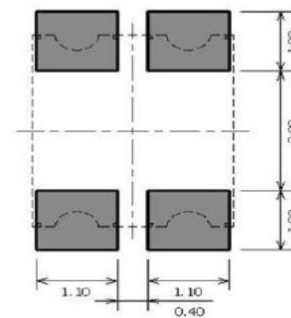
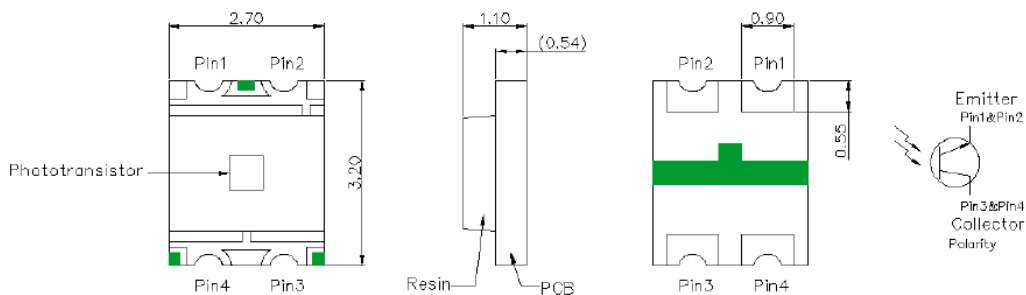

Figure 1. IN-S32GTLS Solder Pattern

## Package Dimensions in mm



### Notes:

1. All dimensions are in millimeters (inches).
2. Tolerance is  $\pm 0.25$  mm (.010 ") unless otherwise noted.

Figure 2. IN-S32GTLS Package Dimensions

## Converting Photocurrent to Voltage

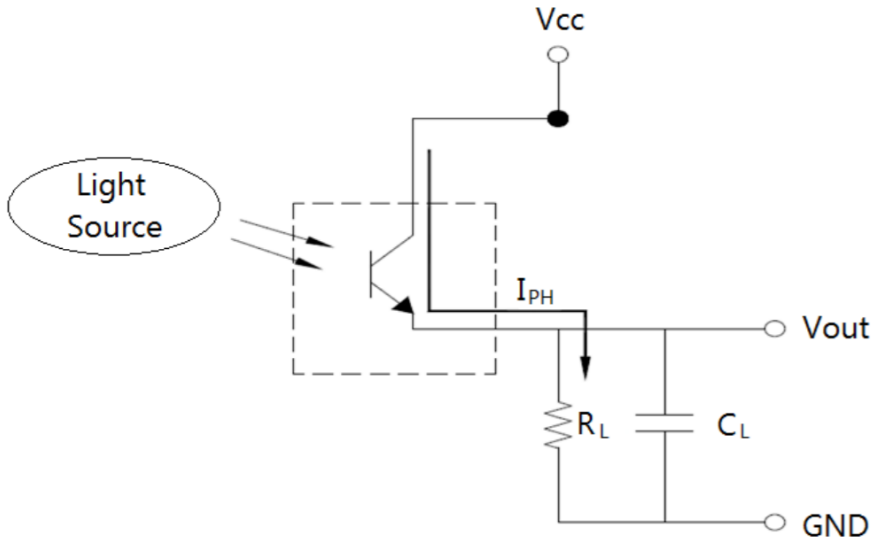

### Notes:

1. The output voltage (V<sub>out</sub>) is the product of photocurrent (I<sub>PH</sub>) and loading resistor (R<sub>L</sub>)
2. A right loading resistor shall be chosen to meet the requirement of maximum ambient light, and output saturation voltage:

$$V_{out(max.)} = I_{PH(max.)} \times R_L \leq V_{out(saturation)} = V_{cc} - 0.4V$$

## Absolute Maximum Rating at 25°C

Symbol	Parameters	Ratings	Units	Notes
BV <sub>CEO</sub>	Collector-Emitter Breakdown Voltage	60	V	1
BV <sub>ECO</sub>	Emitter-Collector Breakdown Voltage	4	V	2
T <sub>opr</sub>	Operating Temperature	-40~+85	°C	
T <sub>stg</sub>	Storage Temperature	-40~+100	°C	
T <sub>sol</sub>	Soldering Temperature	260	°C	3

### Notes

1. Test conditions: I<sub>C</sub>=100μA, E<sub>v</sub>=0 Lx.
2. Test conditions: I<sub>E</sub>=100μA, E<sub>v</sub>=0 Lx.
3. Soldering time ≤ 5 seconds.

### ESD Precaution

ATTENTION: Electrostatic Discharge (ESD) protection



The symbol above denotes that ESD precaution is needed. ESD protection for GaP and AlGaAs based chips is necessary even though they are relatively safe in the presence of low static-electric discharge. Parts built with AlInGaP, GaN, or/and InGaN based chips are STATIC SENSITIVE devices. ESD precaution must be taken during design and assembly. If manual work or processing is needed, please ensure the device is adequately protected from ESD during the process.

Please be advised that normal static precautions should be taken in the handling and assembly of this device to prevent damage or degradation which may be induced by electrostatic discharge (ESD).

## Electro-Optical Characteristics

Symbol	Parameters	Test conditions	Min	Typ	Max	Units	Notes
$\lambda_D$	Rang Of Spectral Bandwidth	---	390	-	700	nm	
$\lambda_P$	Wavelength Of Peak Sensitivity	---	-	630		nm	
$BV_{CEO}$	Collector-Emitter Breakdown Voltage	$I_C=100\mu A$ $E_v=0$ Lx	60	-	-	V	
$BV_{ECO}$	Emitter-Collector Breakdown Voltage	$I_E=100Ma$ $E_v=0$ Lx	4	-	-	V	
$V_{CE(sat)}$	Collector-Emitter Saturation Voltage	$I_C=2mA$ $E_v=1000$ Lx	-	-	0.4	V	
$I_{CEO}$	Collector Dark Current	$V_{CE}=10V$ $E_v=0$ Lx	-	-	100	nA	
$I_{PH1}$	Light Current (1)	$V_{CE}=5V$ , $E_v=100$ Lx	5	30	-	$\mu A$	1
$I_{PH2}$	Light Current (2)	$V_{CE}=5V$ , $E_v=1000$ Lx	50	300	-	$\mu A$	1
$I_{PH3}$	Light Current (3)	$V_{CE}=5V$ , $E_v=1000$ Lx	150	620	-	$\mu A$	2
$I_{PH4}$	Light Current (4)	$V_{CE}=5V$ , $E_v=1000$ Lx	150	790	-	$\mu A$	3
$V_o$	Saturation Output Voltage	$V_{CC}=5V$ , $E_v= 1000$ Lx , $RL=75K$	4.5	4.6		V	

### Notes

1. White LED light (Color Temperature = 6500K) is used as light source.
2. Illuminance by CIE standard illuminant-A / 2856K, incandescent lamp.
3. Sunlight (Color Temperature = 4600K) is used as light source.

## Typical Characteristic Curves

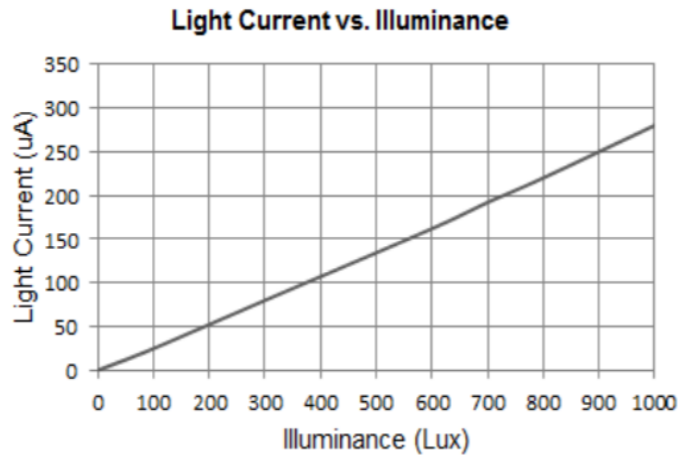
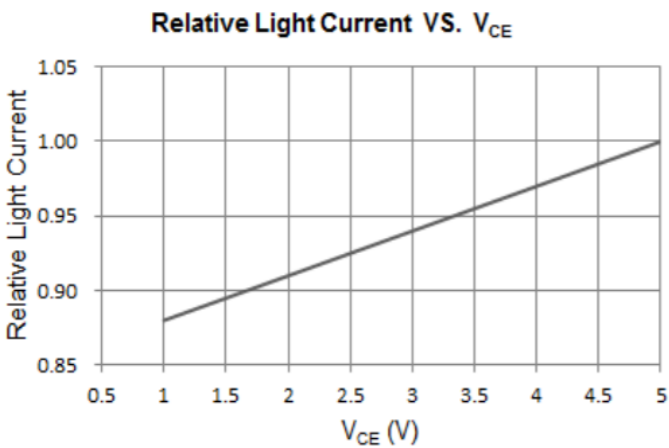
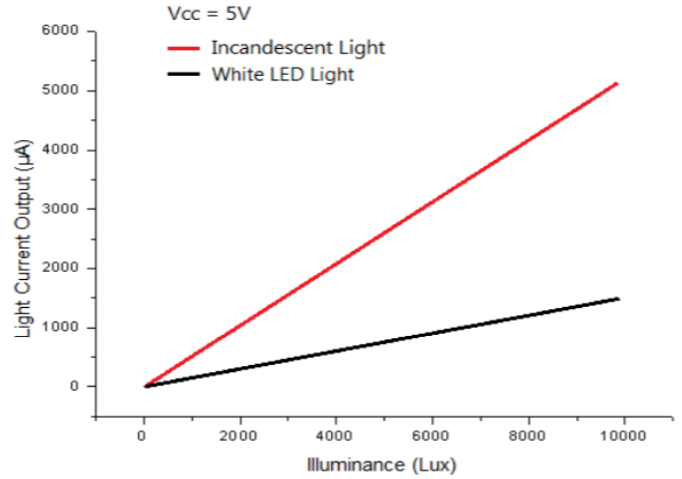
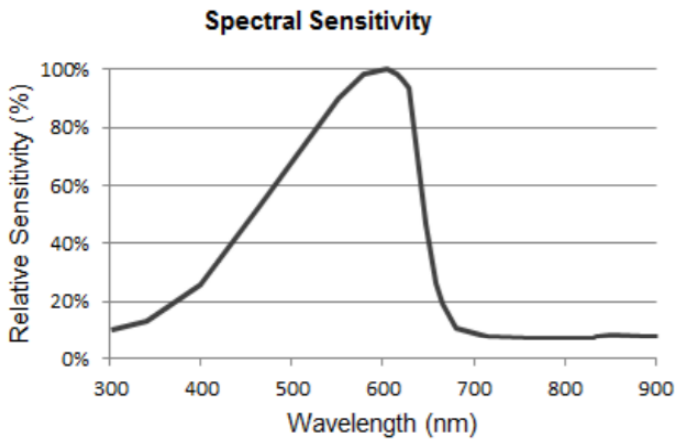

## Ordering Information

Product	Symbol	Parameters	Test conditions	Min	Typ	Max	Units	Orderable Part Number
IN-S32GTLS	IPH1	Light Current (1)	VCE=5V , Ev=100 Lx	5	30	-	μA	IN-S32GTLS
	IPH2	Light Current (2)	VCE=5V , Ev=1000 Lx	50	300	-	μA	
	IPH3	Light Current (3)	VCE=5V , Ev=1000 Lx	150	620	-	μA	

**Label Specifications**

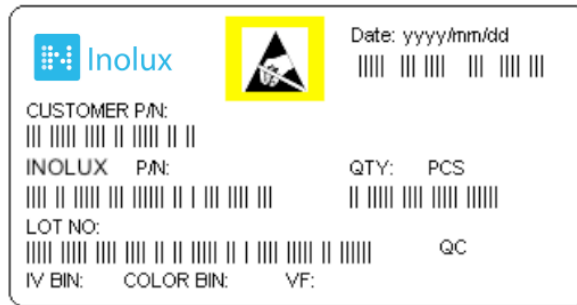

**Inolux P/N:**

I	N	-	S	3	2	G	T		LS	-	-	-	-	-
			Material	Package		Variation	Orientation	Lens	Color		Customized Stamp-off			
Inolux	SMD		S = PCB Type	32G=3.2x2.7 1.1mm			T = Top Mount	(Blank) = Clear U = Diffused	LS=Light sensor					

**Lot No.:**

Z	2	0	1	7	01	24	001
Internal Tracker	Year (2017, 2018, .....)				Month	Date	Serial

**Packaging Information: 3000pcs Per Reel**

**Tape Dimension**

**Packaging  
Tape Dimension**

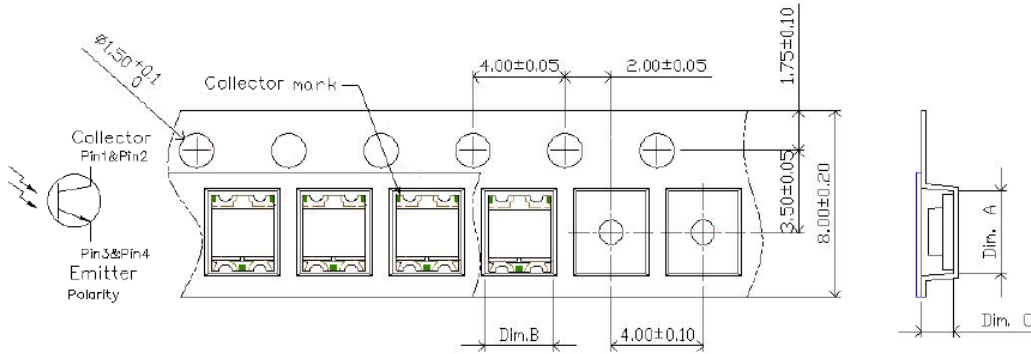

Dim. A	Dim. B	Dim. C	Q'ty/Reel
$3.40 \pm 0.1$	$2.90 \pm 0.1$	$1.30 \pm 0.05$	3K

Unit: mm

**Reel Dimension**

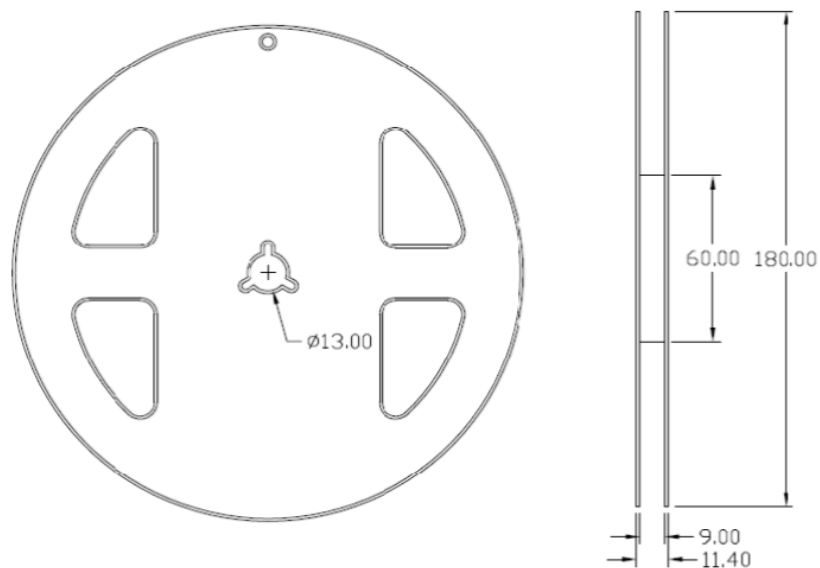

## Packing Dimension

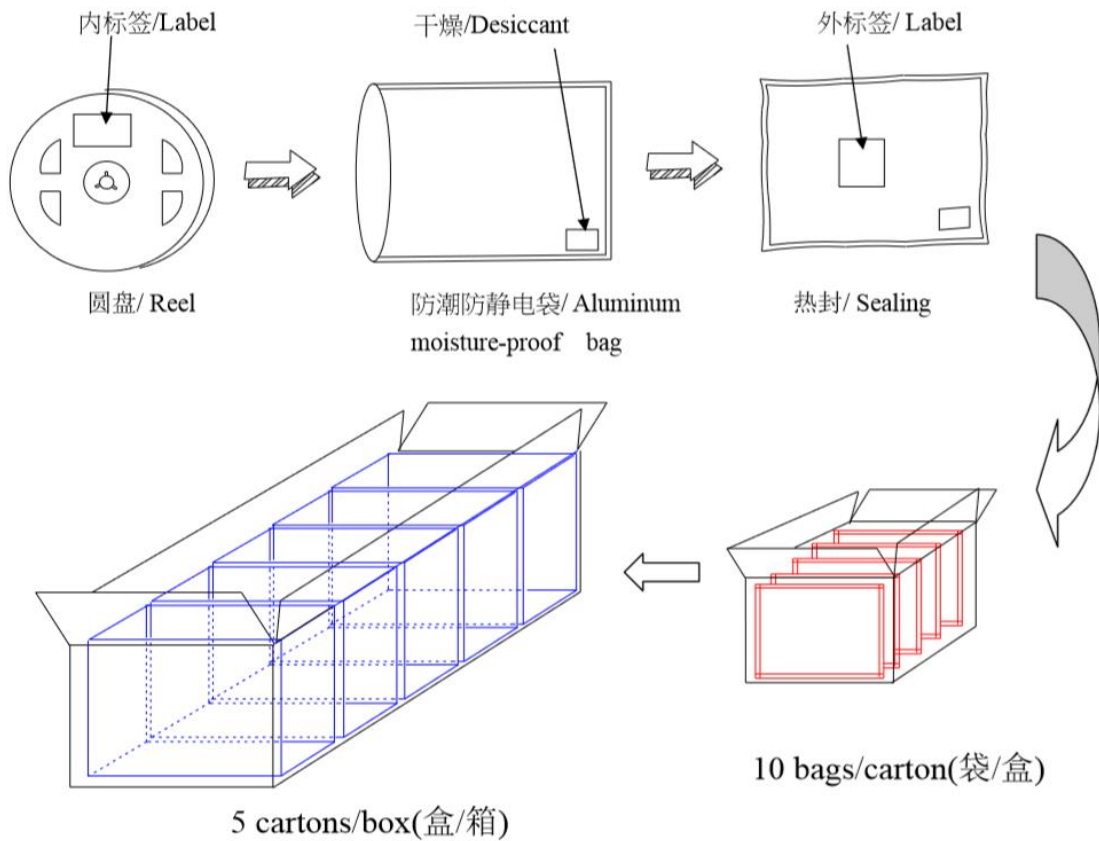

5 boxes per carton are available depending on shipment quantity.

	Specification	Material	Quantity
Carrier tape	Per EIA 481-1A specs	Conductive black tape	3000pcs per reel
Reel	Per EIA 481-1A specs	Conductive black	
Label	IN standard	Paper	
Packing bag	220x240mm	Aluminum laminated bag/ no-zipper	One reel per bag
Carton	IN standard	Paper	Non-specified

**Others:**

Each immediate box consists of 5 reels. The 5 reels may not necessarily have the same lot number or the same bin. Each reel has a label identifying its specification; the immediate box consists of a product label as well.

## Dry Pack

All SMD optical devices are **MOISTURE SENSITIVE**. Avoid exposure to moisture at all times during transportation or storage. Every reel is packaged in a moisture protected anti-static bag. Each bag is properly sealed prior to shipment.

Upon request, a humidity indicator will be included in the moisture protected anti-static bag prior to shipment.

The packaging sequence is as follows:

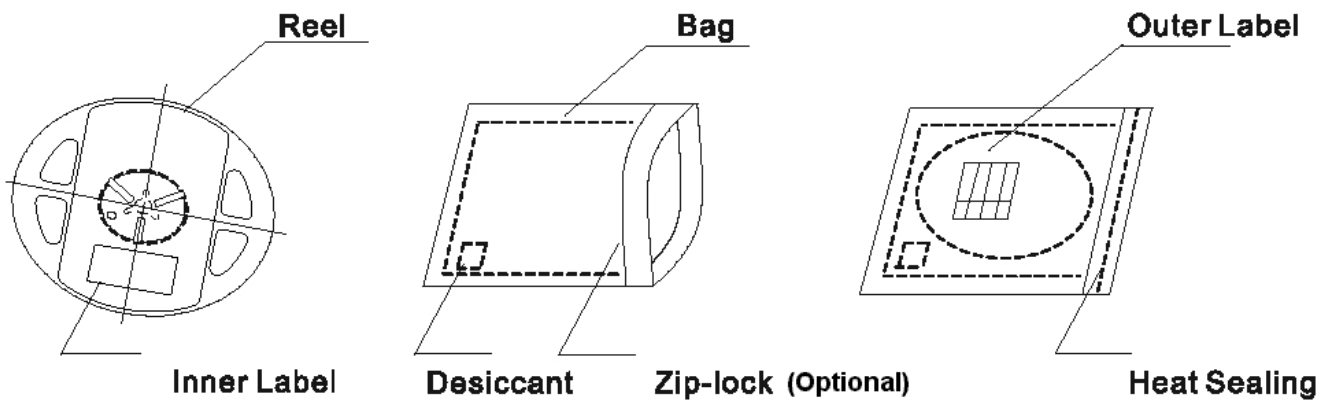

## Reflow Soldering

- Recommended tin glue specifications: melting temperature in the range of 178~192 °C
- The recommended reflow soldering profile is as follows (temperatures indicated are as measured on the surface of the LED resin):

Lead-free Solder Profile

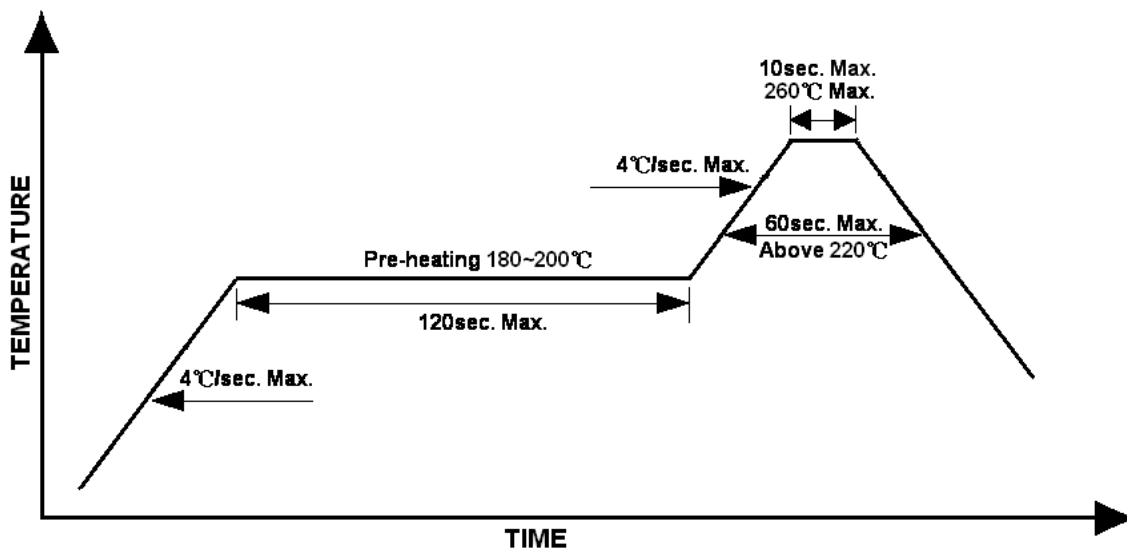

## Precautions

- Avoid exposure to moisture at all times during transportation or storage.
- Anti-Static precaution must be taken when handling GaN, InGaN, and AlInGaP products.
- It is suggested to connect the unit with a current limiting resistor of the proper size. Avoid applying a reverse voltage.
- Avoid operation beyond the limits as specified by the absolute maximum ratings.
- Avoid direct contact with the surface through which the LED emits light.
- If possible, assemble the unit in a clean room or dust-free environment.

### **Reworking**

- Rework should be completed within 5 seconds under 260 °C.
- The iron tip must not come in contact with the copper foil.
- Twin-head type is preferred.

### **Cleaning**

Following are cleaning procedures after soldering:

- An alcohol-based solvent such as isopropyl alcohol (IPA) is recommended.
- Temperature x Time should be 50°C x 30sec. or <30°C x 3min
- Ultra sonic cleaning: < 15W/ bath; bath volume ≤ 1liter
- Curing: 100 °C max, <3min

### **Cautions of Pick and Place**

- Avoid stress on the resin at elevated temperature.
- Avoid rubbing or scraping the resin by any object.
- Electro-static may cause damage to the component. Please ensure that the equipment is properly grounded. Use of an ionizer fan is recommended.

## Reliability

Item	Frequency/ lots/ samples/ failures	Standards Reference	Conditions
Precondition	For all reliability monitoring tests according to JEDEC Level 2	J-STD-020	1.) Baking at 85°C for 24hrs 2.) Moisture storage at 85°C/ 60% R.H. for 168hrs
Solderability	1Q/ 1/ 22/ 0	JESD22-B102-B And CNS-5068	Accelerated aging 155°C/ 24hrs Tinning speed: 2.5+0.5cm/s Tinning: A: 215°C/ 3+1s or B: 260°C/ 10+1s
Resistance to soldering heat		CNS-5067	Dipping soldering terminal only Soldering bath temperature A: 260+/-5°C; 10+/-1s B: 350+/-10°C; 3+/-0.5s
Operating life test	1Q/ 1/ 40/ 0	CNS-11829	1.) Precondition: 85°C baking for 24hrs 85°C/ 60%R.H. for 168hrs 2.) Tamb25°C; IF=20mA; duration 1000hrs
High humidity, high temperature bias	1Q/ 1/ 45/ 0	JESD-A101-B	Tamb: 85°C Humidity: 85% R.H., IF=5mA Duration: 1000hrs
High temperature bias	1Q/ 1/ 20	IN specs.	Tamb: 55°C IF=20mA Duration: 1000hrs
Pulse life test	1Q/ 1/ 40/ 0		Tamb25°C, If=20mA,, Ip=100mA, Duty cycle=0.125 (tp=125 μs, T=1sec) Duration 500hrs)
Temperature cycle	1Q/ 1/ 76/ 0	JESD-A104-A IEC 68-2-14, Nb	A cycle: -40 degree C 15min; +85 degree C 15min Thermal steady within 5 min.. 300 cycles 2 chamber/ Air-to-air type
High humidity storage test	1Q/ 1/ 40/ 0	CNS-6117	60+3°C 90+5/-10% R.H. for 500hrs
High temperature storage test	1Q/ 1/ 40/ 0	CNS-554	100+10°C for 500hrs
Low temperature storage test	1Q/ 1/ 40/ 0	CNS-6118	-40+5°C for 500hrs

## Revision History

Changes since last revision	Page	Version No.	Revision Date
Initial Release		1.0	01-31-2019

## DISCLAIMER

INOLUX reserves the right to make changes without further notice to any products herein to improve reliability, function or design. INOLUX does not assume any liability arising out of the application or use of any product or circuit described herein; neither does it convey any license under its patent rights, nor the rights of others.

## LIFE SUPPORT POLICY

INOLUX's products are not authorized for use as critical components in life support devices or systems without the express written approval of the President of INOLUX or INOLUX CORPORATION. As used herein:

1. Life support devices or systems are devices or systems which, (a) are intended for surgical implant into the body, or (b) support or sustain life, and (c) whose failure to perform when properly used in accordance with instructions for use provided in the labeling, can be reasonably expected to result in a significant injury of the user.
2. A critical component in any component of a life support device or system whose failure to perform can be reasonably expected to cause the failure of the life support device or system, or to affect its safety or effectiveness.

## Looking for pricing, stock, or lifecycle information?

Click below to explore more details on WIN SOURCE:

 [View IN-S32GTLS](#) on WIN SOURCE

 [Inolux](#) Information

## Optimize Your Supply Chain with WIN SOURCE Solutions

-  Global Sourcing Solution
-  Obsolete Management
-  Cost Control Management
-  Shortage Management
-  Alternative Solution
-  Excess Inventory Management