



**THE DATASHEET OF
MAX33042EAKA+T**



MAX33042E

+5V, 4Mbps CAN Transceiver with ±40V Fault Protection, ±25V CMR, and ±40kV ESD in 8-Pin SOT23

General Description

The MAX33042E is a +5V CAN transceiver with integrated protection for industrial applications. This device has extended ±40V fault protection for equipment where overvoltage protection is required. It also incorporates high ±40kV ESD Human Body Model (HBM) protection and an input common-mode range (CMR) of ±25V, exceeding the ISO 11898-2 CAN standard of -2V to +7V. This makes it well suited for applications where there is moderate electrical noise that can influence the ground levels between two nodes or systems.

This device operates at a high-speed CAN data rate, allowing up to 4Mbps on short distance networks. Maximum speed on large networks may be limited by the number of nodes, the type of cabling used, stub length, and other factors. The MAX33042E includes a dominant timeout to prevent bus lockup caused by controller error or by a fault on the TXD input. When the TXD remains in the dominant state (low) for longer than t_{DOM} , the driver is switched to the recessive state, releasing the bus and allowing other nodes to communicate.

The transceiver features a STBY pin for three modes of operation; standby mode for low current consumption, normal high-speed mode, or a slow slew rate mode when an external 26.1kΩ resistor is connected between ground and the STBY pin. A shutdown pin enables the device to further save power consumption where the transmitter and receiver are turned off.

The MAX33042E is available in 8-pin SOT23 and 8-pin SOIC packages. Both packages operate over the -40°C to +125°C temperature range.

Applications

- Industrial Equipment
- Instrumentation
- Motor Control
- Building Automation

Benefits and Features

- Integrated Protection Increases Robustness
 - Increased Protection on CANH and CANL
 - ±40V Fault Tolerant
 - ±40kV ESD HBM Protection
 - ±12kV Contact and ±15kV Air-Gap ESD (ISO 10605, IEC 61000-4-2) Protection
 - ±25V Extended Common-Mode Input Range (CMR)
 - Short-Circuit Protection
 - Transmitter-Dominant Timeout Prevents Lockup
 - Thermal Shutdown
- Provides Flexible Design Options
 - Slow Slew Rate to Minimize EMI
 - Low-Current Standby Mode
 - Shutdown Pin to Save Power
- Small Package Option to Save PCB Area
 - 8-Pin SOT23
- High-Speed Operation of up to 4Mbps
- Operating Temperature Range of -40°C to +125°C

Ordering Information appears at end of data sheet.

Simplified Block Diagram

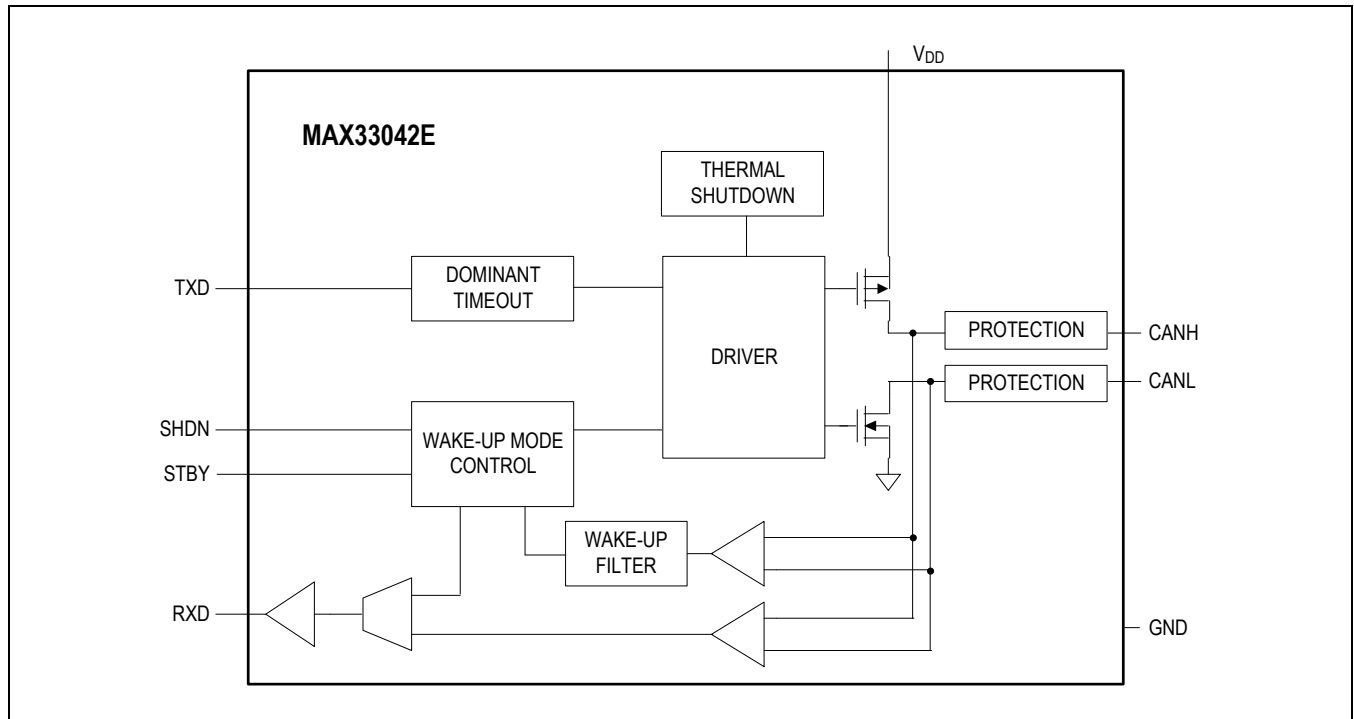

+5V, 4Mbps CAN Transceiver with ±40V Fault Protection, ±25V CMR, and ±40kV ESD in 8-Pin SOT23

MAX33042E

Absolute Maximum Ratings

V _{DD}	-0.3V to +6.0V
CANH or CANL (Continuous)	-40V to +40V
TXD, STBY, SHDN	-0.3V to +6.0V
RXD.....	-0.3V to +6.0V
Short-Circuit Duration.....	Continuous
Continuous Power Dissipation (SOT23)	
Multilayer Board (T _A = +70°C, derate 9.5mW/°C above +70°C) 761.9mW

Continuous Power Dissipation (SOIC)	
Multilayer Board (T _A = +70°C, derate 7.4mW/°C above +70°C) 588.2mW
Operating Temperature Range.....	-40°C to +125°C
Junction Temperature.....	+150°C
Storage Temperature Range	-60°C to +150°C
Soldering Temperature (reflow).....	+260°C
Lead Temperature (soldering, 10s).....	+300°C

Stresses beyond those listed under "Absolute Maximum Ratings" may cause permanent damage to the device. These are stress ratings only, and functional operation of the device at these or any other conditions beyond those indicated in the operational sections of the specifications is not implied. Exposure to absolute maximum rating conditions for extended periods may affect device reliability.

Package Information

8 SOT23

Package Code	K8CN+2C
Outline Number	21-0078
Land Pattern Number	90-0176
Thermal Resistance, Four-Layer Board	
Junction to Ambient (θ _{JA})	105°C/W
Junction to Case (θ _{JC})	42.3°C/W

8 SOIC

Package Code	S8+2C
Outline Number	21-0041
Land Pattern Number	90-0096
Thermal Resistance, Four-Layer Board	
Junction to Ambient (θ _{JA})	136°C/W
Junction to Case (θ _{JC})	38°C/W

For the latest package outline information and land patterns (footprints), go to www.maximintegrated.com/packages. Note that a "+", "#", or "-" in the package code indicates RoHS status only. Package drawings may show a different suffix character, but the drawing pertains to the package regardless of RoHS status.

Package thermal resistances were obtained using the method described in JEDEC specification JESD51-7, using a four-layer board. For detailed information on package thermal considerations, refer to www.maximintegrated.com/thermal-tutorial.

Electrical Characteristics

(V_{DD} = 4.5V to 5.5V, R_{LD} = 60Ω, C_{LD} = 100pF, C_L = 15pF, T_A = T_{MIN} to T_{MAX}, unless otherwise specified. Typical values are at V_{DD} = 5.0V and T_A = +25°C, unless otherwise specified.) (Note 1)

PARAMETER	SYMBOL	CONDITIONS	MIN	TYP	MAX	UNITS
POWER						

**+5V, 4Mbps CAN Transceiver with
±40V Fault Protection, ±25V CMR,
and ±40kV ESD in 8-Pin SOT23**

MAX33042E

($V_{DD} = 4.5V$ to $5.5V$, $R_{LD} = 60\Omega$, $C_{LD} = 100pF$, $C_L = 15pF$, $T_A = T_{MIN}$ to T_{MAX} , unless otherwise specified. Typical values are at $V_{DD} = 5.0V$ and $T_A = +25^\circ C$, unless otherwise specified.) (Note 1)

PARAMETER	SYMBOL	CONDITIONS		MIN	TYP	MAX	UNITS
Supply Voltage	V_{DD}			4.5		5.5	V
Dominant Supply Current	I_{DD_DOM}	TXD = SHDN = STBY = 0V	No load		5	9	mA
			$R_{LD} = 60\Omega$		50	70	
Recessive Supply Current	I_{DD_REC}	$V_{DD} = TXD = 5.0V$, STBY = SHDN = 0V	No load		3		mA
			CANH shorted to CANL		3		
Shutdown Current	I_{SHDN}	SHDN = STBY = TXD = V_{DD}			0.03	3	μA
Standby Supply Current	I_{STBY}	STBY = TXD = V_{DD}			45	70	μA
UVLO Threshold Rising	V_{UVLO_R}	V_{DD} rising				4.25	V
UVLO Threshold Falling	V_{UVLO_F}	V_{DD} falling		3.45			V
FAULT PROTECTION							
ESD Protection (CANH, CANL to GND)			HBM, JEDEC JS-001-2017		±40		kV
			Air-Gap ISO 10605, IEC 61000-4-2		±15		
			Contact ISO 10605, IEC 61000-4-2		±12		
ESD Protection (All Other Pins)			HBM		±4		kV
Fault Protection Range	V_{FP}	CANH or CANL to GND		-40		+40	V
Thermal Shutdown	T_{SHDN}				+160		$^\circ C$
Thermal Shutdown Hysteresis	T_{HYST}				+20		$^\circ C$
LOGIC INTERFACE (RXD, TXD, STBY, SHDN)							
Input High Voltage	V_{IH}			0.7 x V_{DD}			V
Input Low Voltage	V_{IL}	TXD, SHDN				0.8	V
TXD Input Pullup Resistance	R_{PU_TXD}			100		250	k Ω
STBY Input Pullup Resistance	R_{PU_STBY}			100		250	k Ω
Slow Slew Rate Resistor	R_{SLEW_ON}	External resistor size from STBY to ground to enable slow slew rate mode			26.1		k Ω
SHDN Input Pulldown Resistance	R_{PD_SHDN}			1			M Ω
Output High Voltage	V_{OH}	Sourcing 4mA, TXD = V_{DD}		$V_{DD} -$ 0.4V			V
Output Low Voltage	V_{OL}	Sinking 4mA, TXD = 0V				0.4	V
CAN BUS DRIVER							
Bus Output Voltage (Dominant)	V_{O_DOM}	$t < t_{DOM}$, TXD = 0V	CANH		2.75	4.5	V
			CANL		0.5	2.25	
Bus Output Voltage (Recessive)	V_{O_REC}	TXD = V_{DD} , no load	CANH		2	3	V
			CANL		2	3	
Bus Output Differential Voltage (Dominant)	V_{OD_DOM}	TXD = 0V	$R_{CM} = 156\Omega$, -5V $\leq V_{CM} \leq +10V$, Figure 1		1.5	3	V
			$R_{CM} = \text{open}$		1.5	3	

**+5V, 4Mbps CAN Transceiver with
±40V Fault Protection, ±25V CMR,
and ±40kV ESD in 8-Pin SOT23**

MAX33042E

($V_{DD} = 4.5V$ to $5.5V$, $R_{LD} = 60\Omega$, $C_{LD} = 100pF$, $C_L = 15pF$, $T_A = T_{MIN}$ to T_{MAX} , unless otherwise specified. Typical values are at $V_{DD} = 5.0V$ and $T_A = +25^\circ C$, unless otherwise specified.) (Note 1)

PARAMETER	SYMBOL	CONDITIONS		MIN	TYP	MAX	UNITS
Output Voltage Standby	V_{O_STBY}	TXD = STBY = V_{DD} , no load		70		160	mV
Bus Output Differential Voltage (Recessive)	V_{OD_REC}	TXD = V_{DD}	$R_{LD} = 60\Omega$	-120		+12	mV
			No load	-500		+50	
Short-Circuit Current	I_{SC_CANH}	TXD = 0V, CANH = -40V			2	5	mA
	I_{SC_CANL}	TXD = 0V, CANL = +40V			2	5	
RECEIVER							
Common-Mode Input Range	V_{CM}	CANH or CANL to GND, RXD output valid		-25		+25	V
Common-Mode Input Range Standby Mode	V_{CM_STBY}	CANH or CANL to GND, RXD output valid		-12		+12	V
Input Differential Voltage (Dominant)	V_{ID_DOM}	$-25V \leq V_{CM} \leq +25V$, TXD = V_{DD}				0.9	V
Input Differential Voltage (Recessive)	V_{ID_REC}	$-25V \leq V_{CM} \leq +25V$, TXD = V_{DD}		0.5			V
Standby Input Differential Voltage (Dominant)	$V_{ID_STBYDOM}$	$-12V \leq V_{CM} \leq +12V$, TXD = V_{DD}				1.15	V
Standby Input Differential Voltage (Recessive)	$V_{ID_STBYREC}$	$-12V \leq V_{CM} \leq +12V$, TXD = V_{DD}		0.45			V
Input Differential Hysteresis	V_{ID_HYS}	$-25V \leq V_{CM} \leq +25V$			90		mV
Input Resistance	R_{IN}	TXD = V_{DD}		10		50	k Ω
Differential Input Resistance	R_{IN_DIFF}	TXD = V_{DD}		20		100	k Ω
Input Capacitance	C_{IN}	TXD = V_{DD} (Note 2)			18	35	pF
Differential Input Capacitance	C_{IN_DIFF}	TXD = V_{DD} (Note 2)			9	18	pF
Input Leakage Current	I_{LKG}	$V_{DD} = 0V$, CANH = CANL = 5.0V			150	250	μA
SWITCHING							
Driver Rise Time	t_R	R_{CM} = open, Figure 1	$V_{STBY} = 0V$		5		ns
			26.1k Ω resistor from STBY to GND		40		
Driver Fall Time	t_F	R_{CM} = open, Figure 1	$V_{STBY} = 0V$		10		ns
			26.1k Ω resistor from STBY to GND		80		
TXD to RXD Loop Delay	t_{LOOP}	STBY = 0V	Dominant to Recessive, Figure 2		60	100	ns
			Recessive to Dominant, Figure 2		60	100	
TXD Propagation Delay (Recessive to Dominant)	t_{ONTXD}	$V_{DD} = 5V$, R_{CM} is open, Figure 1			25	50	ns
TXD Propagation Delay (Dominant to Recessive)	t_{OFFTXD}	$V_{DD} = 5V$, R_{CM} is open, Figure 1			25	50	ns

+5V, 4Mbps CAN Transceiver with ±40V Fault Protection, ±25V CMR, and ±40kV ESD in 8-Pin SOT23

MAX33042E

($V_{DD} = 4.5V$ to $5.5V$, $R_{LD} = 60\Omega$, $C_{LD} = 100pF$, $C_L = 15pF$, $T_A = T_{MIN}$ to T_{MAX} , unless otherwise specified. Typical values are at $V_{DD} = 5.0V$ and $T_A = +25^\circ C$, unless otherwise specified.) (Note 1)

PARAMETER	SYMBOL	CONDITIONS	MIN	TYP	MAX	UNITS
RXD Propagation Delay (Recessive to Dominant)	t_{ONRXD}	$V_{DD} = 5V$, Figure 3		40	70	ns
RXD Propagation Delay (Dominant to Recessive)	t_{OFFRXD}	$V_{DD} = 5V$, Figure 3		30	70	ns
TXD-Dominant Timeout	t_{DOM}	Figure 4	1.3		4.3	ms
Wake-Up Time	t_{WAKE}	Figure 5		2		μs
Standby Propagation Delay (Dominant to Recessive)	t_{PLH_STBY}	$STBY = V_{DD}$, Figure 5		350		ns
Standby to Normal Mode Delay	t_{D_STBYN}	$C_L = 15pF$, Figure 6		20		μs
Normal to Standby Dominant Delay	t_{D_NSTBY}	$C_L = 15pF$, Figure 6		35		μs
Shutdown to Normal Delay	t_{D_SHDNN}	$C_L = 15pF$, Figure 7		25		μs

Note 1: All units are 100% production tested at $T_A = +25^\circ C$. Specifications over temperature are guaranteed by design.

Note 2: Not production tested. Guaranteed at $T_A = +25^\circ C$.

Timing Diagrams

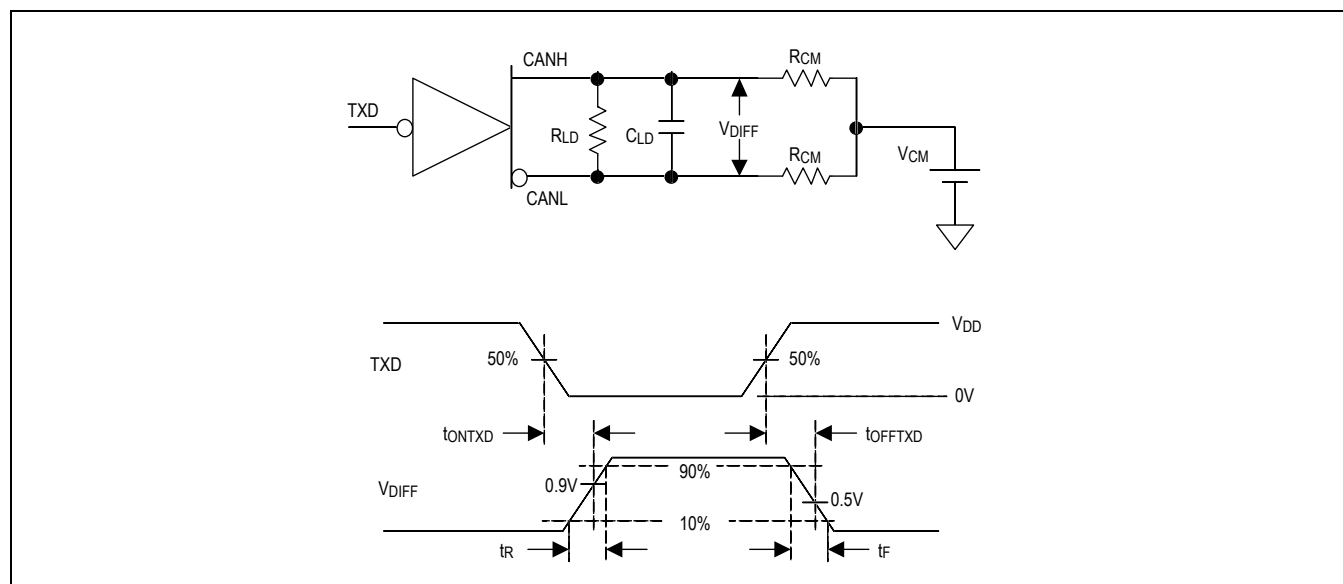

Figure 1. Transmitter Test Circuit and Timing Diagram

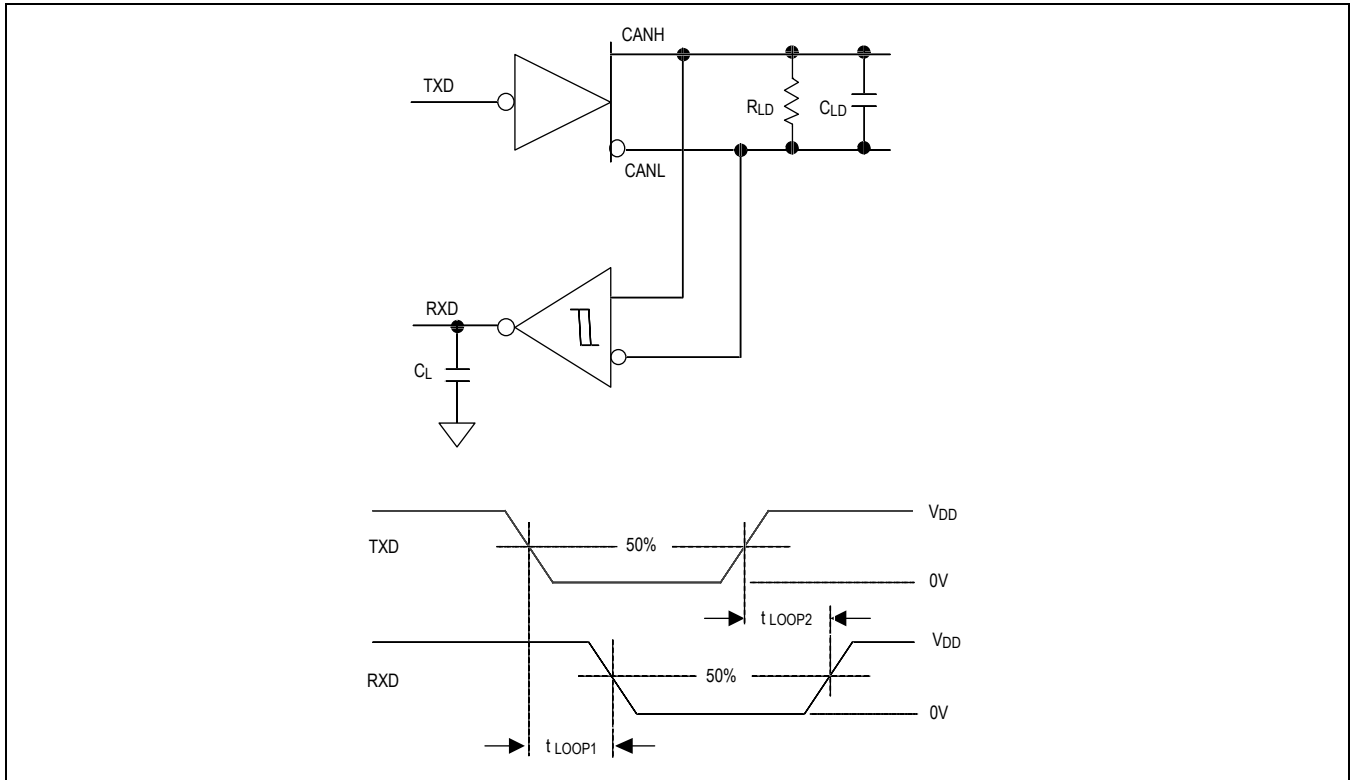

Figure 2. TXD to RXD Loop Delay

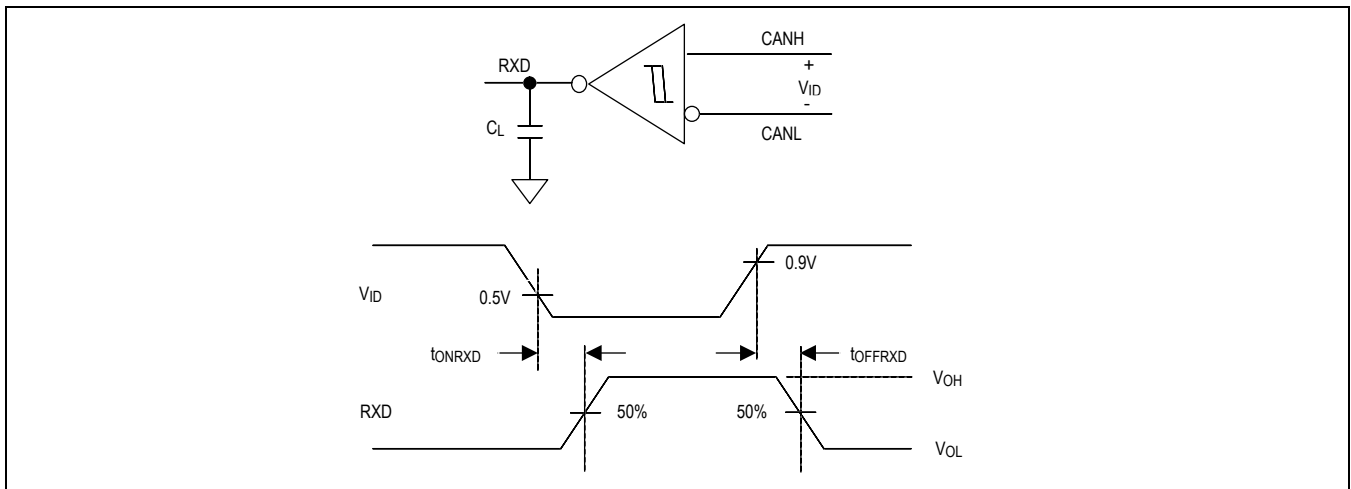

Figure 3. RXD Timing Diagram

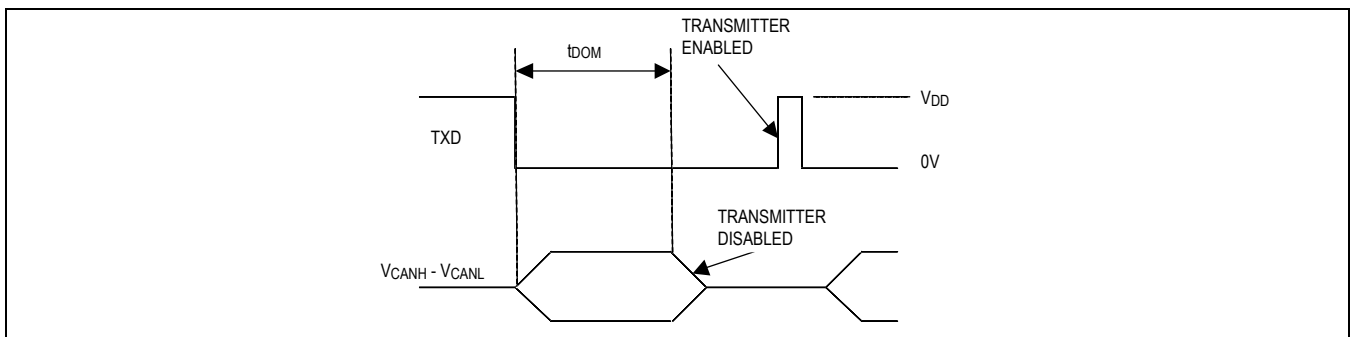

Figure 4. Transmitter-Dominant Timeout Timing Diagram

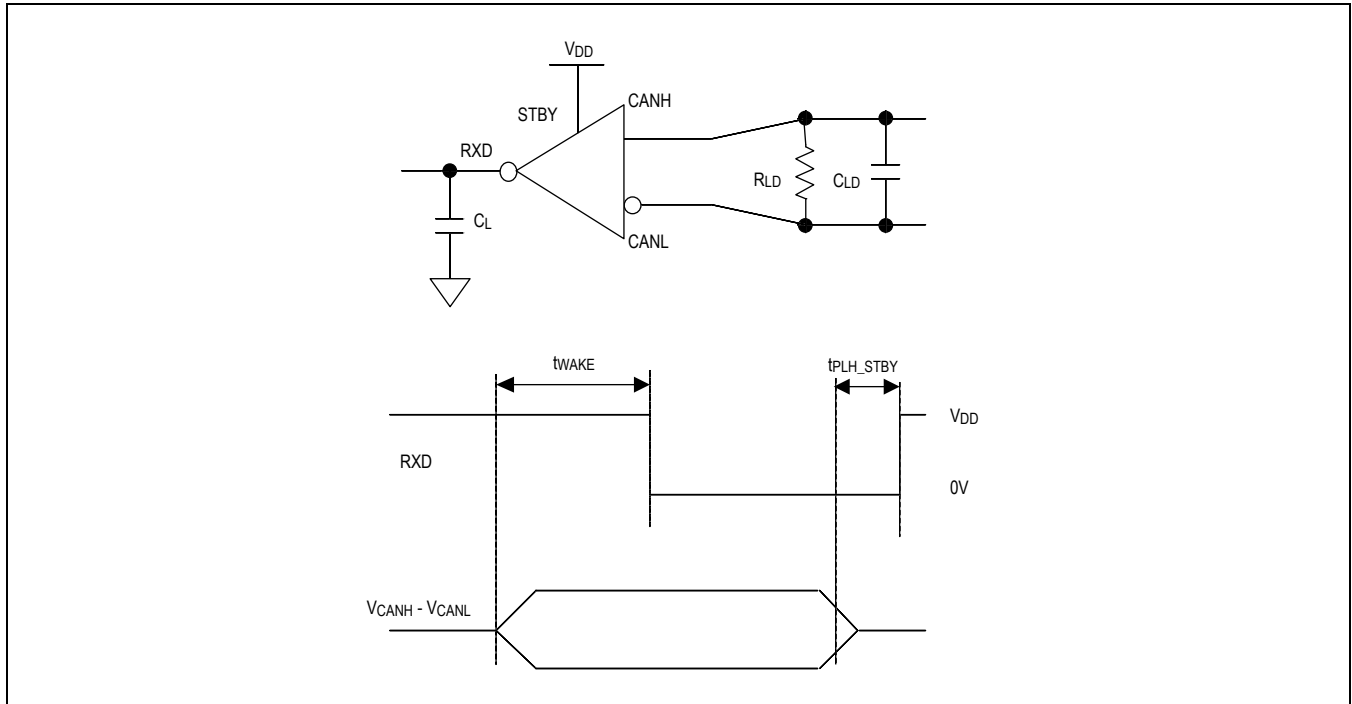

Figure 5. Standby Receiver Propagation Delay

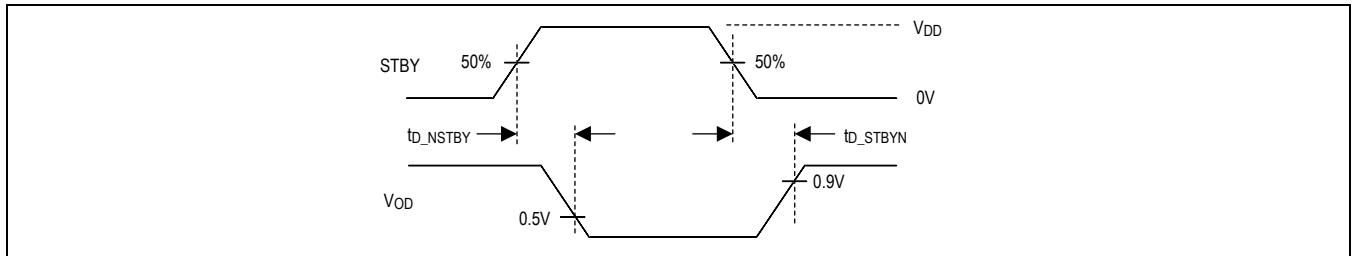

Figure 6. Standby Mode Timing Diagram

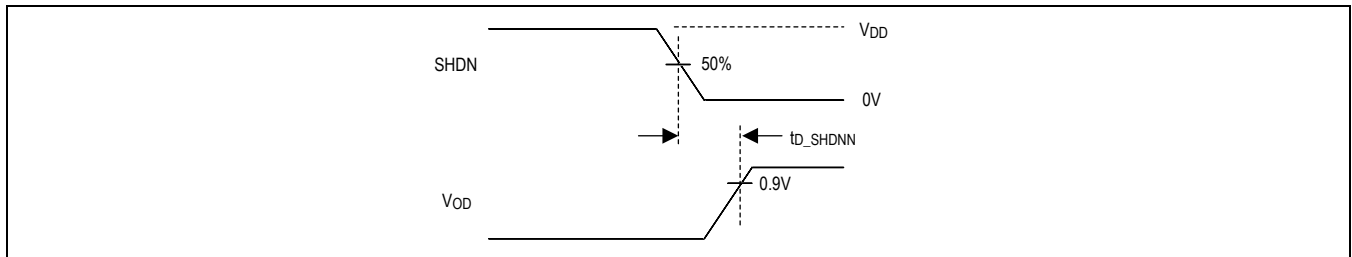

Figure 7. Shutdown Mode Timing Diagram

+5V, 4Mbps CAN Transceiver with ±40V Fault Protection, ±25V CMR, and ±40kV ESD in 8-Pin SOT23

MAX33042E

Typical Operating Characteristics

$V_{DD} = 5V$, $R_{LD} = 60\Omega$, $C_{LD} = 100pF$, $C_L = 15pF$, $T_A = +25^\circ C$, unless otherwise noted.

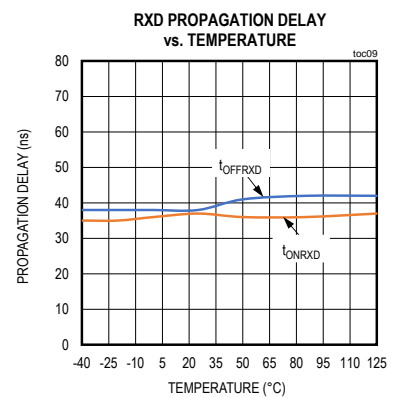
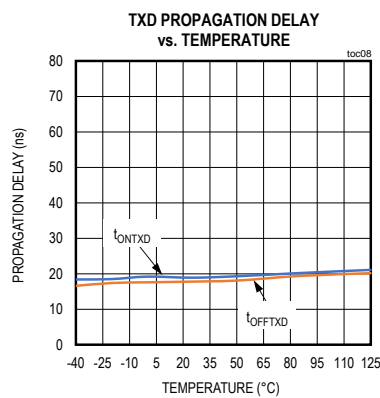
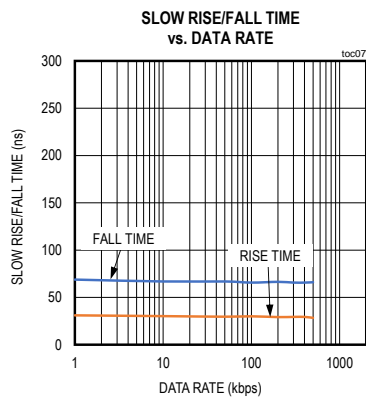
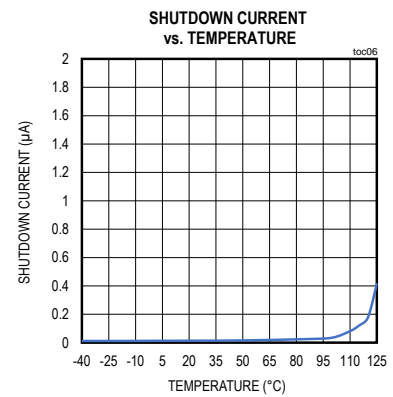
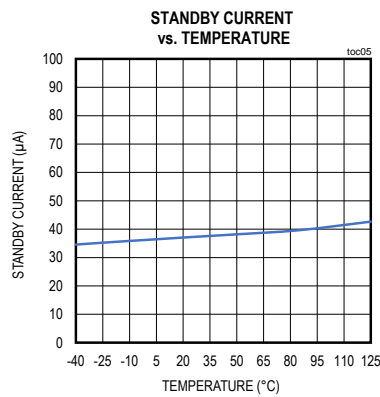
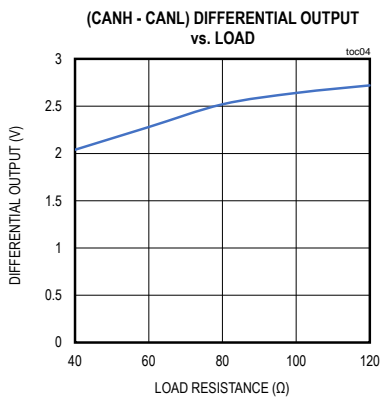
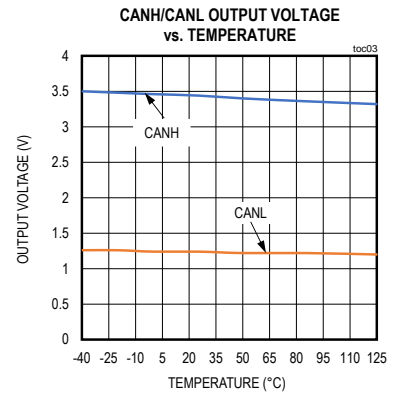
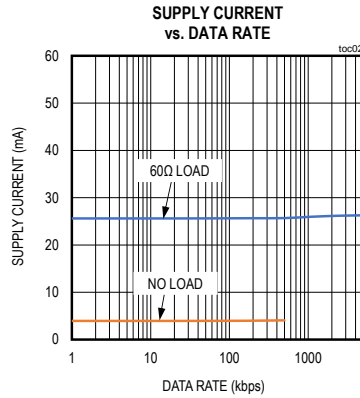
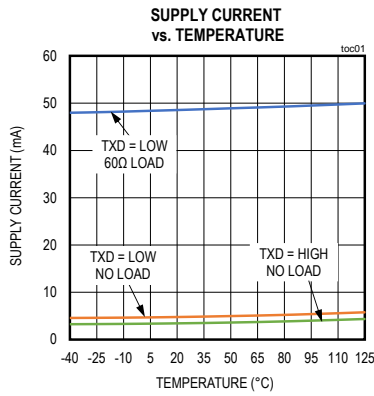

+5V, 4Mbps CAN Transceiver with ±40V Fault Protection, ±25V CMR, and ±40kV ESD in 8-Pin SOT23

MAX33042E

$V_{DD} = 5V$, $R_{LD} = 60\Omega$, $C_{LD} = 100pF$, $C_L = 15pF$, $T_A = +25^\circ C$, unless otherwise noted.

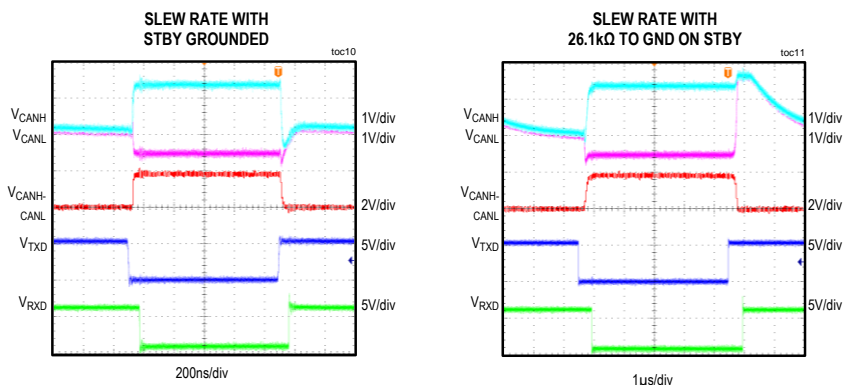

Pin Configurations

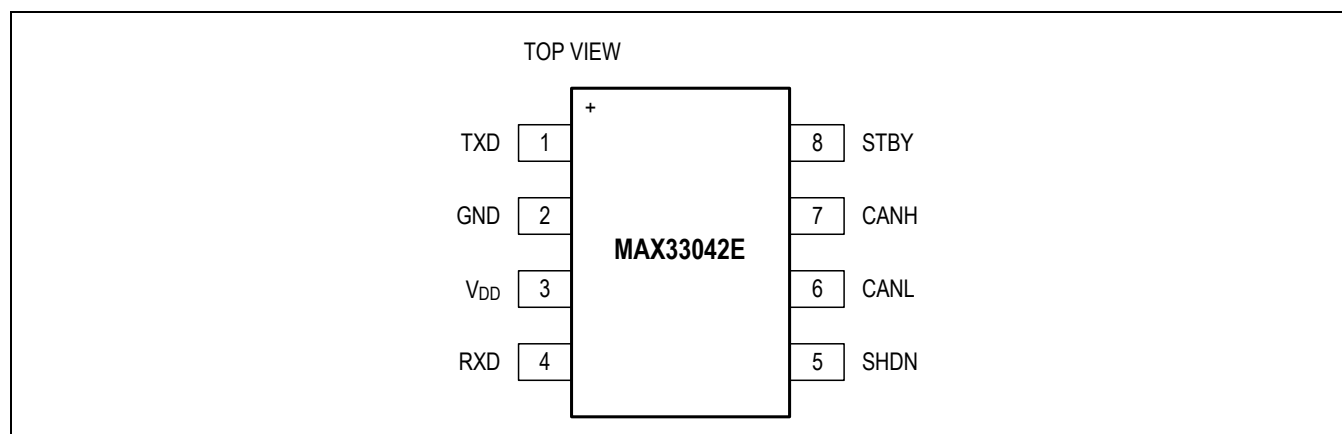

Pin Descriptions

PIN	NAME	FUNCTION
1	TXD	Transmit Data Input. Drive TXD high to set the driver in the recessive state. Drive TXD low to set the driver in the dominant state. TXD has an internal pullup to V_{DD} .
2	GND	Ground
3	V_{DD}	Supply Voltage. Bypass V_{DD} to GND with a $0.1\mu F$ capacitor.
4	RXD	Receive Data Output. RXD is high when CANH and CANL are in the recessive state. RXD is low when CANH and CANL are in the dominant state.
5	SHDN	Shutdown input, CMOS/TTL compatible. Drive SHDN high to put MAX33042E in shutdown. SHDN has an internal pulldown resistor to GND.
6	CANL	CAN Bus-Line Low
7	CANH	CAN Bus-Line High
8	STBY	Standby Mode. A logic-high on STBY pin selects the standby mode. In standby mode, the transceiver is not able to transmit data and the receiver is in low-power mode. A logic-low on STBY pin puts the transceiver in normal operating mode. A $26.1k\Omega$ external resistor can be used to connect the STBY pin to ground for the slow slew rate.

Functional Diagrams

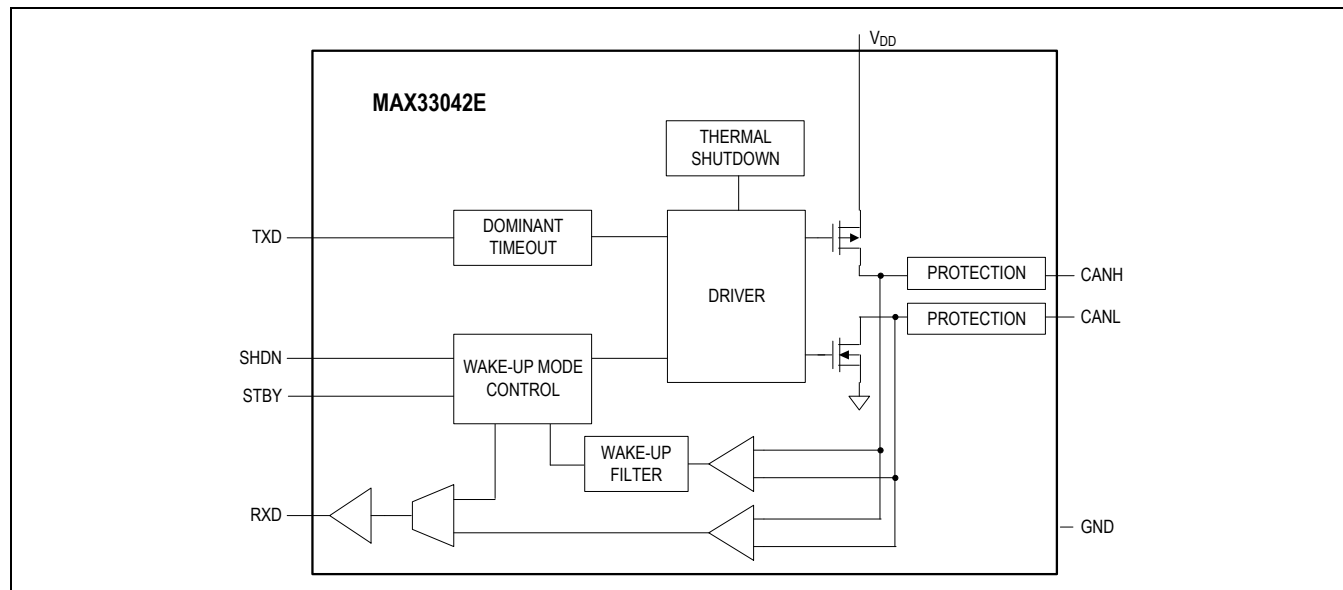

Detailed Description

The MAX33042E is a fault-protected CAN transceiver designed for industrial applications with a number of integrated robust protection features. This device provides a link between the CAN protocol controller and the physical wires of the bus lines in a control area network (CAN). They can be used for DeviceNet™ applications as well.

The CAN transceiver is fault-protected on CANH and CANL up to ±40V, making it suitable for applications where overvoltage protection is required. This device is rated up to a high ±40kV ESD HBM on CANH and CANL, suitable for protection during the manufacturing process, and even in the field where there is human interface for installation and maintenance. In addition, a common-mode voltage of ±25V enables communication in noisy environments where there are ground plane differences between different systems due to the close proximity of heavy equipment machinery or operation from different transformers. This device's dominant timeout prevents the bus from being blocked by a hung-up microcontroller. The CANH and CANL outputs are short-circuit, current-limited, and protected against excessive power dissipation by thermal shutdown circuitry that places the driver outputs in a high-impedance state.

These devices can operate up to 4Mbps with a standby mode where it shuts off the transmitter and reduces the current to 45µA, typ.

±40V Fault Protection

The MAX33042E features ±40V of fault protection. The CANH and CANL data lines are capable of withstanding a short from -40V to +40V. This extended overvoltage range makes The MAX33042E suitable for applications where accidental shorts to power supply lines are possible due to human intervention.

Transmitter

The transmitter converts a single-ended input signal (TXD) from the local CAN controller to differential outputs for the CANH and CANL bus lines. The truth table for the transmitter and receiver is provided in Table 1.

Transmitter Output Protection

The MAX33042E protects the transmitter output stage against a short-circuit to a positive or negative voltage by limiting the driver current. Thermal shutdown further protects the devices from excessive temperatures that may result from a short or high ambient temperature. The transmitter returns to normal operation once the temperature is reduced below the threshold.

Transmitter-Dominant Timeout

The device features a transmitter-dominant timeout (t_{DOM}) that prevents erroneous CAN controllers from clamping the bus to a dominant level by maintaining a continuous low TXD signal. When TXD remains in the dominant state (low) for greater than 2.5ms typical t_{DOM} , the transmitter is disabled, releasing the bus to a recessive state (Figure 4). After a dominant timeout fault, the transmitter is re-enabled when receiving a rising edge at TXD. The transmitter-dominant timeout limits the minimum possible data rate to 9kbps for standard CAN protocol.

Receiver

The receiver reads the differential input from the bus line CANH and CANL and transfers this data as a single-ended output RXD to the CAN controller. It consists of a comparator that senses the difference, $V_{DIFF} = (CANH - CANL)$, with respect to an internal threshold of 0.7V. If $V_{DIFF} > 0.9V$, a logic-low is present on RXD. If $V_{DIFF} < 0.5V$, a logic-high is present. The CANH and CANL common-mode range is ±25V. RXD is a logic-high when CANH and CANL are shorted or terminated and undriven.

Standby Mode

Drive the STBY pin high for standby mode, which switches the transmitter off and the receiver to a low current and low-speed state. The supply current is reduced during standby mode. The bus line is monitored by a low differential comparator to detect and recognize a wakeup event on the bus line. Once the comparator detects a dominant bus level greater than 2μs typical t_{WAKE} , RXD pulls low. Drive the STBY pin low for normal operation.

Slow Slew Rate

Connect a 26.1kΩ resistor between ground and the STBY pin to reduce the slew rate on the transmitter output. The STBY pin voltage should be between 0.1V to 0.6V to remain in slow slew rate. This will change the MAX33042E with a slow slew rate of 50V/μs for rising edge compared with normal mode at 200V/μs. For falling edge, the slow slew rate is 30V/μs compared with normal mode at 110V/μs.

Table 1. Transmitter and Receiver Truth Table (When Not Connected to the Bus)

MODE	TXD	TXD LOW TIME	CANH	CANL	BUS STATE	RXD
Normal (STBY = low)	Low	< t_{DOM}	High	Low	Dominant	Low
Normal (STBY = low)	Low	> t_{DOM}	$V_{DD}/2$	$V_{DD}/2$	Recessive	High
Normal (STBY = low)	High	X	$V_{DD}/2$	$V_{DD}/2$	Recessive	High
Standby (STBY = high)	X	X	High	Low	Dominant	Low
Standby (STBY = high)	X	X	$V_{DD}/2$	$V_{DD}/2$	Recessive	High
Shutdown (SHDN = STBY = high)	X	X	$V_{DD}/2$	$V_{DD}/2$	Recessive	High

X = Don't care

Shutdown Mode

Drive the SHDN pin high for shutdown mode, which switches the transmitter and receiver off. The supply current is reduced to maximum of 3μA during shutdown mode. Drive the SHDN pin low for normal operation.

Applications Information

Reduced EMI and Reflections

In multidrop CAN applications, it is important to maintain a single linear bus of uniform impedance that is properly terminated at each end. A star, ring, or tree configuration should never be used. Any deviation from the end-to-end wiring scheme creates a stub. High-speed data edges on a stub can create reflections back down to the bus. These reflections can cause data errors by eroding the noise margin of the system.

Although stubs are unavoidable in a multidrop system, care should be taken to keep these stubs as short as possible, especially when operating with high data rates.

Typical Application Circuits

Multidrop CAN Bus

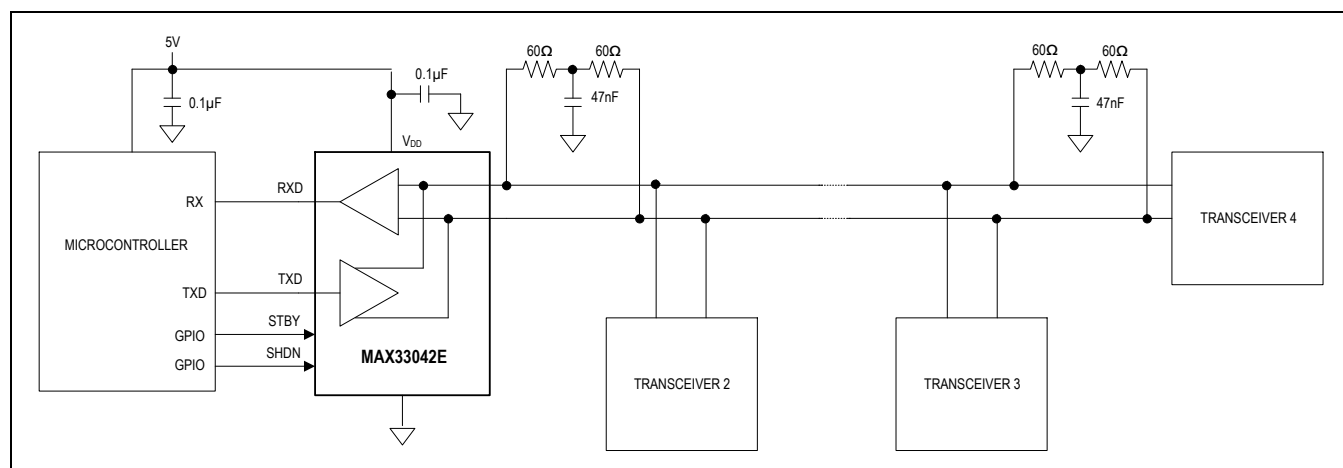

Ordering Information

PART NUMBER	TEMP RANGE	PIN-PACKAGE
MAX33042EASA+	-40°C to +125°C	8 SO
MAX33042EASA+T	-40°C to +125°C	8 SO
MAX33042EAKA+	-40°C to +125°C	8 SOT23
MAX33042EAKA+T	-40°C to +125°C	8 SOT23

+Denotes a lead (Pb)-free/RoHS-compliant package.

*Future product—contact factory for availability.

+5V, 4Mbps CAN Transceiver with
±40V Fault Protection, ±25V CMR,
and ±40kV ESD in 8-Pin SOT23

MAX33042E

Revision History

REVISION NUMBER	REVISION DATE	DESCRIPTION	PAGES CHANGED
0	1/21	Release for market intro	—
1	12/21	Updated Typical Applications Circuits, Multidrop CAN Bus	13
2	1/22	Updated Ordering Information	13



Looking for pricing, stock, or lifecycle information?

Click below to explore more details on WIN SOURCE:

- ⊖ [View MAX33042EAKA+T on WIN SOURCE](#)
- ⊖ [Maxim Integrated Information](#)

Optimize Your Supply Chain with WIN SOURCE Solutions

- ✓ Global Sourcing Solution
- ✓ Obsolete Management
- ✓ Cost Control Management
- ✓ Shortage Management
- ✓ Alternative Solution
- ✓ Excess Inventory Management