



**THE DATASHEET OF
1ED3125MU12FXUMA1**



EiceDRIVER™ 1ED312xMU12F Compact

Datasheet

Single-channel 3.0 kV (rms) isolated gate driver IC with active Miller clamp or separate output

Feature list

- Single channel isolated gate driver
- For use with 600 V/650 V/1200 V/1700 V/2300 V IGBTs, Si and SiC MOSFETs
- Up to 14.0 A typical peak output current
- 40 V absolute maximum output supply voltage
- High common-mode transient immunity CMTI > 200 kV/μs
- Separate source and sink outputs or active Miller clamp with active shutdown and short circuit clamping
- Galvanically isolated coreless transformer gate driver
- 3.3 V and 5 V input supply voltage
- Suitable for operation at high ambient temperature and in fast switching applications
- UL 1577 certification $V_{ISO} = 3.0$ kV (rms) for 1 min (File E311313)

Potential applications

- AC and brushless DC motor drives
- High voltage DC-DC converter and DC-AC inverter
- Induction heating resonant application
- UPS-systems
- Commercial air-conditioning (CAC)
- Server and telecom switched mode power supplies (SMPS)
- Solar inverters, e.g. for 1500 V (DC) systems



PG-DSO-8

Product validation

Qualified for industrial applications according to the relevant tests of JEDEC47/20/22.

Device information

Product type	Typical output current and configuration	UVLO ($V_{UVLOL2,min}$)	Certification (File E311313)	Package marking
1ED3124MU12F	14.0 A separate source and sink	10.5 V	UL	3124MU12
1ED3125MU12F	10.0 A and 3.0 A clamp	10.5 V	UL	3125MU12
1ED3127MU12F	10.0 A and 3.0 A clamp	12.0 V	UL	3127MU12

Description

Description

The 1ED312xMU12F (1ED-X3 Compact) gate driver ICs are galvanically isolated single channel gate driver ICs for IGBT, MOSFET and SiC MOSFET in PG-DSO-8 package. They provide a typical output current of up to 14.0 A on separate source and sink pins or a typical output current of 10.0 A with an additional 3.0 A active Miller clamp.

The input logic pins operate on a wide input voltage range from 3 V to 15 V using CMOS threshold levels to support 3.3 V microcontrollers.

Data transfer across the isolation barrier is realized by the coreless transformer technology.

All variants have logic input and driver output undervoltage lockout (UVLO), and active shutdown.

The gate drivers are certified according to UL 1577

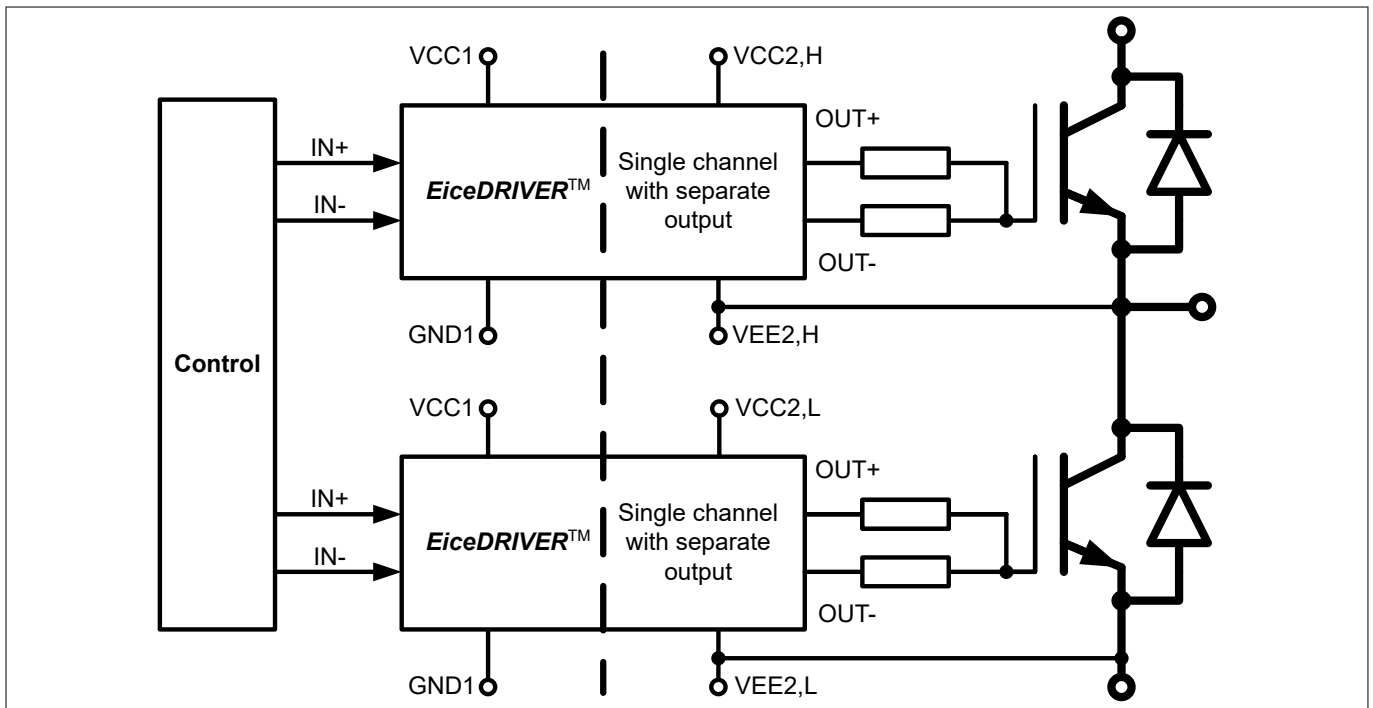

Figure 1 Typical application using separate output variant

Table of contents

	Table of contents	3
1	Block diagram reference	4
2	Related products	5
3	Pin configuration and description	6
4	Functional description	8
4.1	Supply	8
4.2	Protection features	9
4.2.1	Undervoltage lockout (UVLO)	9
4.2.2	Active shut-down	9
4.2.3	Short circuit clamping	9
4.2.4	Active Miller clamp	9
4.3	Non-inverting and inverting inputs	10
4.4	Driver outputs	10
5	Electrical characteristics and parameters	11
5.1	Absolute maximum ratings	11
5.2	Operating parameters	12
5.3	Electrical characteristics	13
5.3.1	Power supply	13
5.3.2	Logic input	13
5.3.3	Gate driver	14
5.3.4	Dynamic characteristics	14
5.3.5	Active shut down	15
6	Insulation characteristics	16
6.1	Recognized under UL 1577 (File E311313)	16
7	Package dimensions	17
	Revision history	17
	Disclaimer	18

1 Block diagram reference

1 Block diagram reference

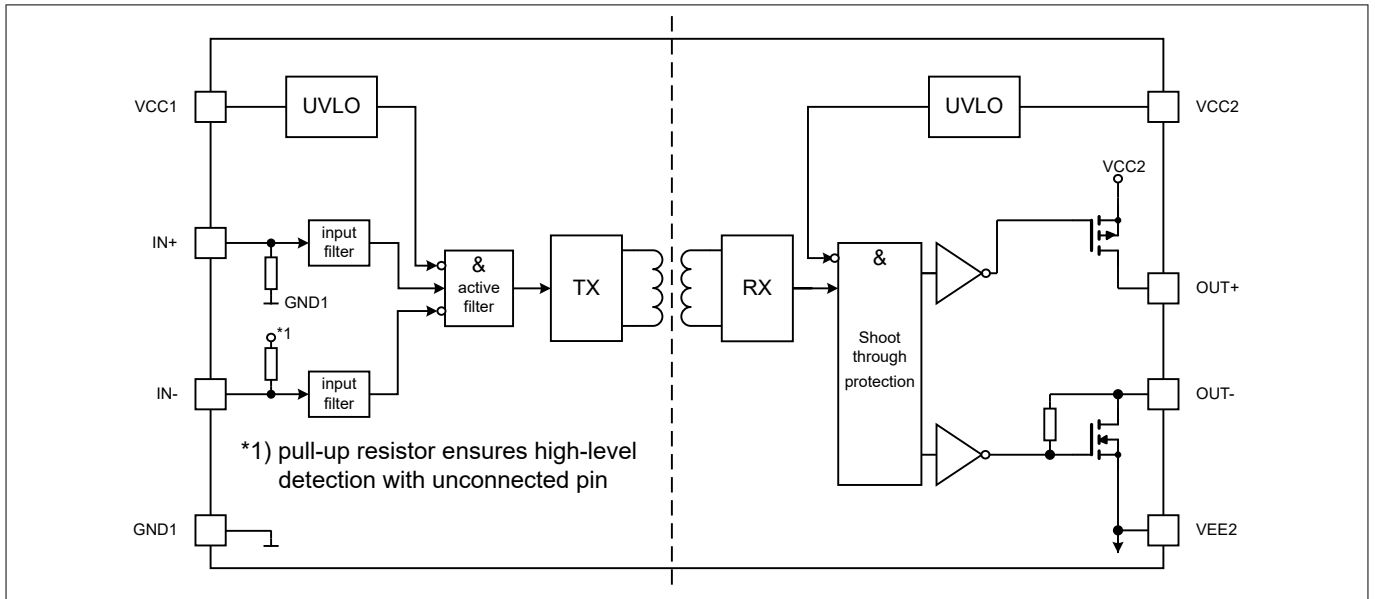

Figure 2 Block diagram separate source and sink output variants

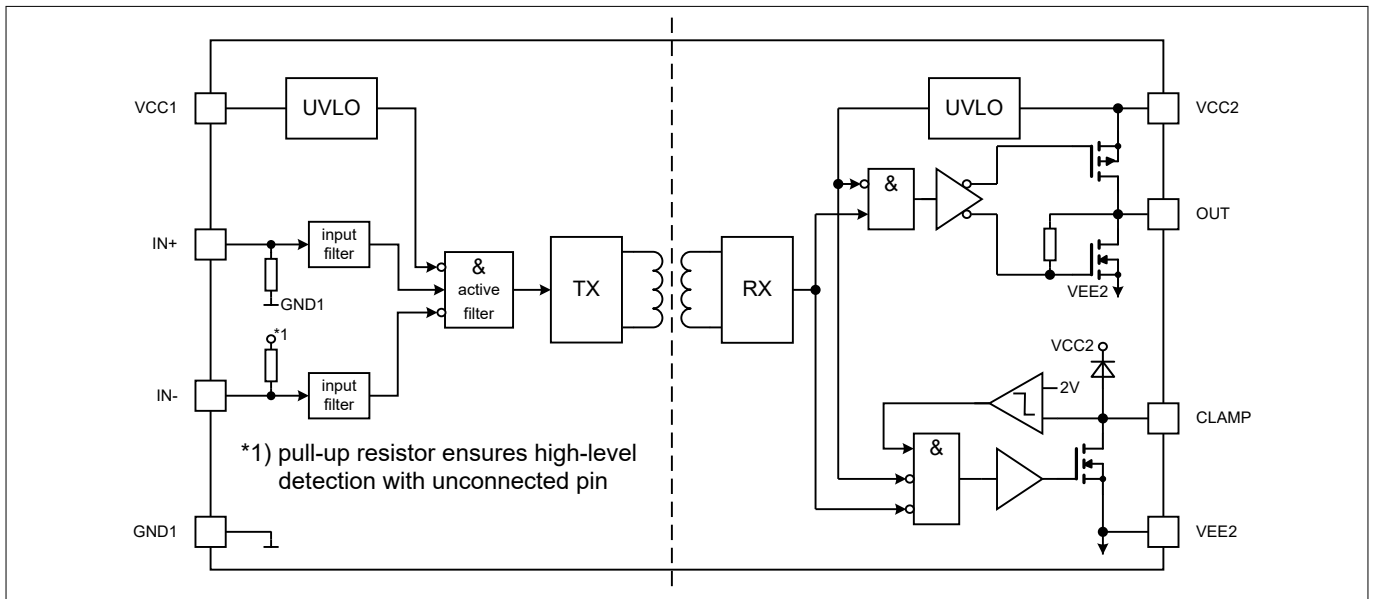

Figure 3 Block diagram output with CLAMP variants

2 Related products

2 Related products

Note: Please consider the gate driver IC power dissipation and insulation requirements for the selected power switch and operating condition.

Product group	Product name	Description
TRENCHSTOP™ IGBT Discrete	IKWH40N65WR6	650 V, 40 A IGBT with anti-parallel diode in TO-247-3-HCC
	IHW30N160R5	1600 V, 30 A IGBT Discrete with anti-parallel diode in TO-247
	IKW15N120CS7	1200 V IGBT7 S7, 15 A IGBT with anti-parallel diode in TO247
	IKQ75N120CS7	1200 V IGBT7 S7, 75 A IGBT with anti-parallel diode in TO247-3
CoolSiC™ SiC MOSFET Discrete	IMBF170R1K0M1	1700 V, 1000 mΩ SiC MOSFET in TO-263-7 with extended creepage
	IMZA120R040M1H	1200 V, 40 mΩ SiC MOSFET in TO247-4 package
	IMZA120R014M1H	1200 V, 14 mΩ SiC MOSFET in TO247-4 package
	IMBG120R030M1H	1200 V, 30 mΩ SiC MOSFET in TO-263-7 package
	IMYH200R012M1H	2000 V, 12 mΩ SiC MOSFET in TO-247-PLUS with high creepage and clearance
CoolSiC™ SiC MOSFET Module	FS33MR12W1M1H_B11	EasyPACK™ 1B 1200 V, 33 mΩ sixpack module
	FF17MR12W1M1H_B11	EasyDUAL™ 1B 1200 V, 17 mΩ half-bridge module
	FF4MR12W2M1H_B11	EasyDUAL™ 2B 1200 V, 4 mΩ half-bridge module
	F4-17MR12W1M1H_B11	EasyPACK™ 1B 1200 V, 17 mΩ fourpack module
TRENCHSTOP™ IGBT Modules	F4-100R17N3E4	EconoPACK™ 3 1700 V, 100 A fourpack IGBT module
	F4-200R17N3E4	EconoPACK™ 3 1700 V, 200 A fourpack IGBT module
	FP10R12W1T7_B11	EasyPIM™ 1B 1200 V, 10 A three phase input rectifier PIM IGBT module
	FS100R12W2T7_B11	EasyPACK™ 2B 1200 V, 100 A sixpack IGBT module
	FP150R12KT4_B11	EconoPIM™ 3 1200V three-phase PIM IGBT module
	FS200R12KT4R_B11	EconoPACK™ 3 1200 V, 200 A sixpack IGBT module

Table 1 Evaluation boards

Part number	Description
EVAL-1ED3121MX12H	Half-bridge evaluation board for 1ED3121MU12H
EVAL-1ED3122MX12H	Half-bridge evaluation board for 1ED3122MU12H
EVAL-1ED3124MX12H	Half-bridge evaluation board for 1ED3124MU12H

3 Pin configuration and description

3 Pin configuration and description

Pin configuration PG-DSO-8 of 1ED3124MU12F

Table 2 Pin configuration

Pin No.	Name	Function
1	VCC1	Positive logic supply
2	IN+	Non-inverted driver input (active high)
3	IN-	Inverted driver input (active low)
4	GND1	Logic ground
5	VCC2	Positive power supply output side
6	OUT+	Driver source output
7	OUT-	Driver sink output
8	VEE2	Power ground

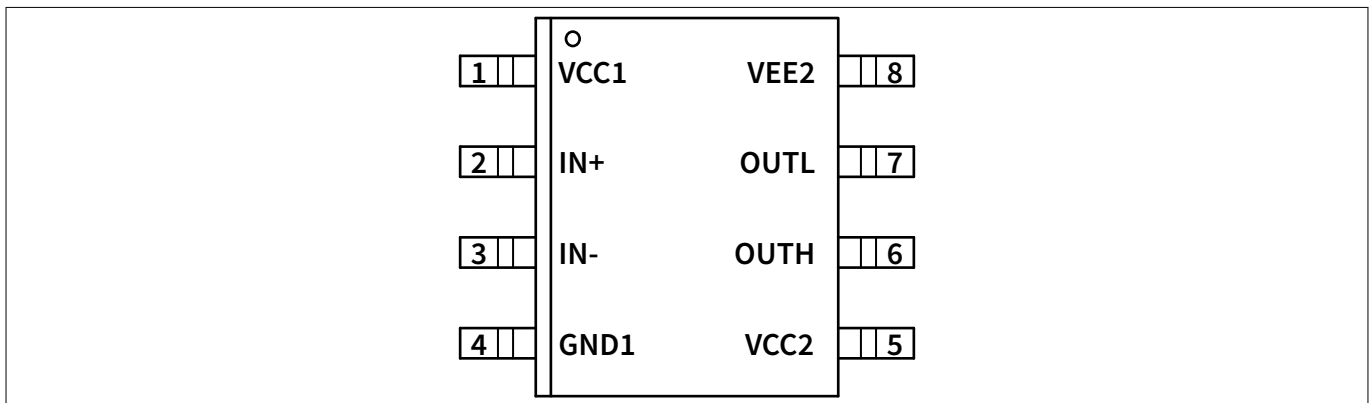

Figure 4 PG-DSO-8 (top view)

Pin configuration PG-DSO-8 of 1ED3125MU12F, 1ED3127MU12F

Table 3 Pin configuration

Pin No.	Name	Function
1	VCC1	Positive logic supply
2	IN+	Non-inverted driver input (active high)
3	IN-	Inverted driver input (active low)
4	GND1	Logic ground
5	VCC2	Positive power supply output side
6	OUT	Driver source and sink output
7	CLAMP	Active Miller clamp output
8	VEE2	Power ground

3 Pin configuration and description

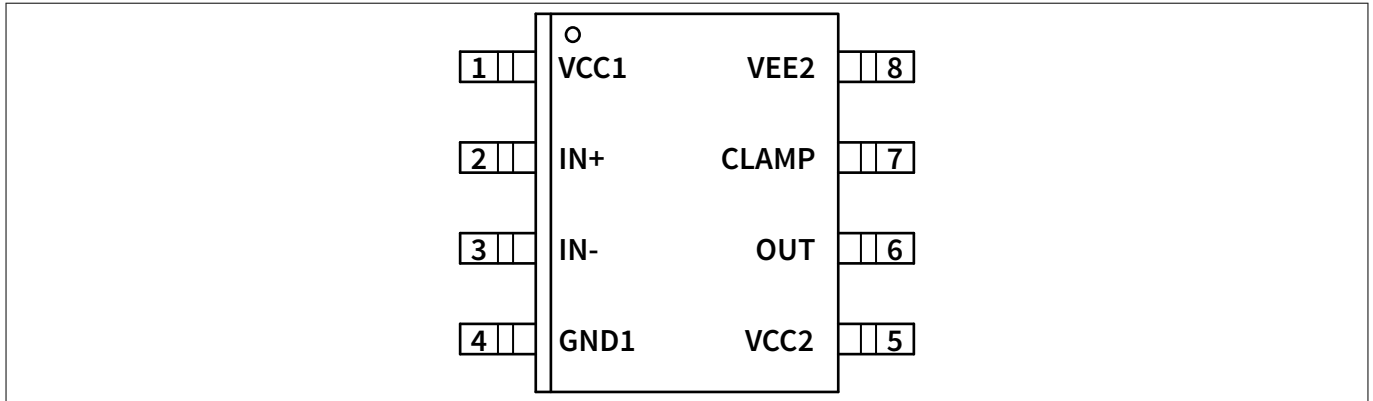

Figure 5 PG-DSO-8 (top view)

Pin description

- *VCC1*: Logic input supply voltage of 3.3 V up to 15 V wide operating range
- *GND1*: Ground connection of input circuit.
- *IN+*: Non-inverted control signal for driver output. An internal filter provides robustness against noise at *IN+*. An internal weak pull-down resistor favors off-state.
- *IN-*: Inverted control signal for driver output. An internal filter provides robustness against noise at *IN-*. An internal weak pull-up resistor favors off-state.
- *VCC2*: Positive power supply pin of output driving circuit. A proper blocking capacitor has to be placed close to this supply pin.
- *VEE2*: Reference ground of the output driving circuit. In case of a bipolar supply (positive and negative voltage referred to IGBT emitter) this pin is connected to the negative supply voltage.
- *OUT+*: Driver source output pin to turn on external IGBT. During on-state the driving output is switched to *VCC2*. Switching of this output is controlled by *IN+* and *IN-*. This output will also be turned off at an UVLO event.
- *OUT-*: Driver sink output pin to turn off external IGBT. During off-state the driving output is switched to *VEE2*. Switching of this output is controlled by *IN+* and *IN-*. In case of UVLO an active shut down keeps the output voltage at a low level.
- *OUT*: Combined source and sink output pin to external IGBT. The output voltage will be switched between *VCC2* and *VEE2*. Switching of this output is controlled by *IN+* and *IN-*. In case of an UVLO event this output will be switched off and an active shut down keeps the output voltage at a low level.
- *CLAMP*: The clamp function ties its output to *VEE2* during off-state. It activates as soon as the gate voltage has dropped below 2.0 V referred to *VEE2* after a turn-off command. Connect this pin directly to the IGBT gate to avoid parasitic turn-on of the connected IGBT.

4 Functional description

4 Functional description

The 1ED312xMU12F (1ED-X3 Compact) are general purpose IGBT gate drivers. Basic control and protection features support fast and easy design of highly reliable systems.

The integrated galvanic isolation between control input logic and driving output stage grants additional safety. Its input voltage supply range supports the direct connection of various signal sources like DSPs and microcontrollers.

4.1 Supply

The driver can operate over a wide supply voltage range, either unipolar or bipolar.

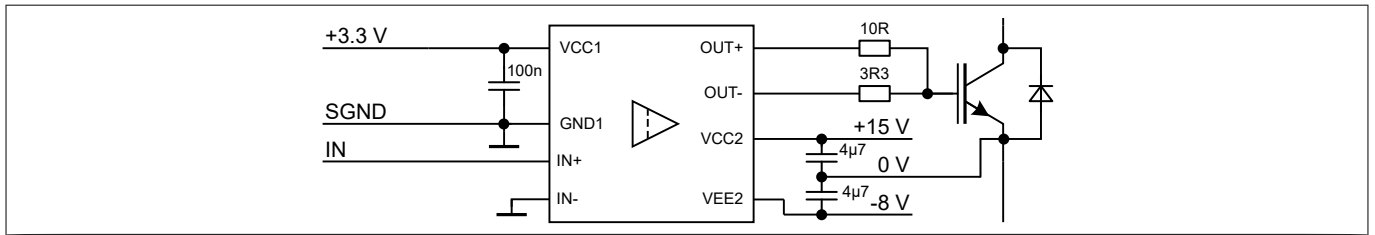

Figure 6 Application example bipolar supply

With bipolar supply the driver is typically operated with a positive voltage of 15 V at VCC2 and a negative voltage of -8 V at VEE2 relative to the emitter of the IGBT. Negative supply can help to prevent a dynamic turn on due to the additional charge which is generated from IGBT's input capacitance.

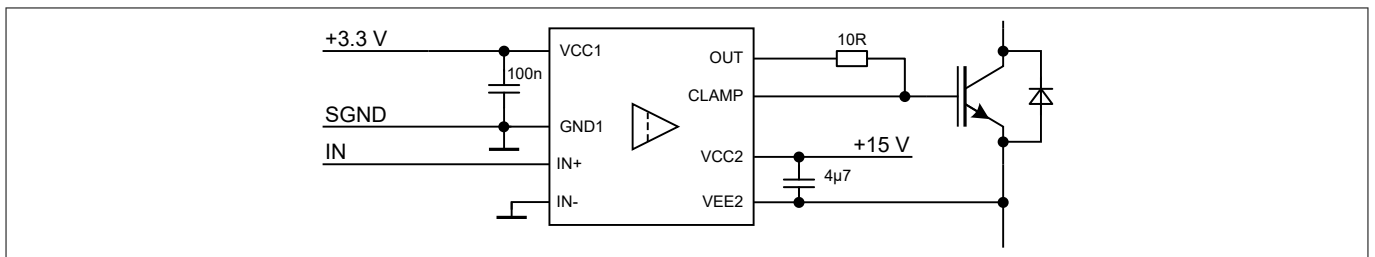

Figure 7 Application example unipolar supply

For unipolar supply configuration the driver is typically supplied with a positive voltage of 15 V at VCC2. In this case, careful evaluation for turn off gate resistor selection is recommended to avoid dynamic turn on. Both supply options are usable with either output configuration separate source and sink as well as output with active Miller clamp.

4 Functional description

4.2 Protection features

4.2.1 Undervoltage lockout (UVLO)

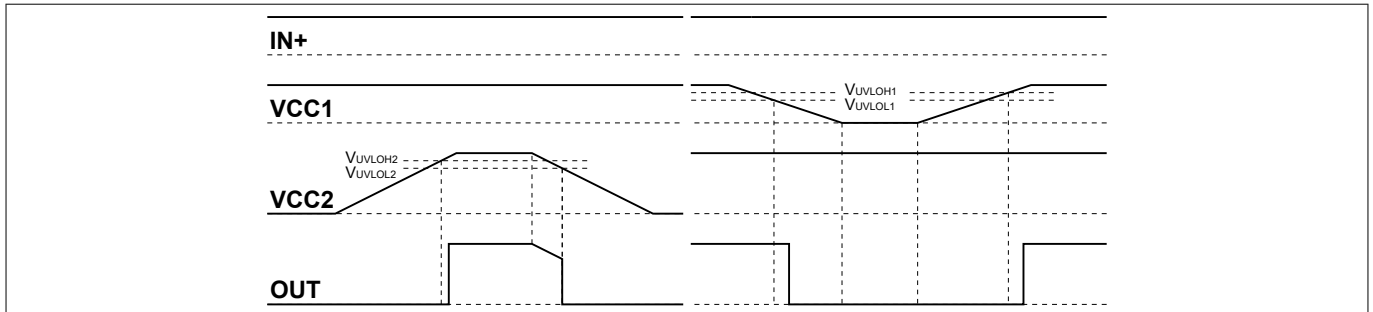

Figure 8 UVLO behavior

To ensure correct switching of IGBTs the device is equipped with an undervoltage lockout for input and output independently. Operation starts only after both VCC levels have increased beyond the respective V_{UVLOH} levels.

If the power supply voltage V_{VCC1} of the input chip drops below V_{UVLOL1} a turn-off signal is sent to the output chip before power-down. The IGBT is switched off and the signals at $IN+$ and $IN-$ are ignored until V_{VCC1} reaches the power-up voltage V_{UVLOH1} again.

If the power supply voltage V_{VCC2} of the output chip goes down below V_{UVLOL2} the IGBT is switched off and signals from the input chip are ignored until V_{VCC2} reaches the power-up voltage V_{UVLOH2} again.

Note: V_{VCC2} is always referred to $VEE2$ and does not differentiate between unipolar or bipolar supply.

4.2.2 Active shut-down

The active shut-down feature ensures a safe IGBT off-state in case the output chip is not connected to the power supply or an undervoltage lockout is in effect. The IGBT gate is clamped at $OUT-$ or $CLAMP$ to $VEE2$.

4.2.3 Short circuit clamping

During short circuit the IGBTs gate voltage tends to rise because of the feedback via the Miller capacitance. An internal protection circuit at $OUT+$ or $CLAMP$ limits this voltage to a value slightly higher than the supply voltage. A maximum current of 500 mA may be fed back to the supply through this path for 10 μ s. If higher currents are expected or tighter clamping is desired external Schottky diodes may be added.

4.2.4 Active Miller clamp

In a half bridge configuration the switched off IGBT tends to dynamically turn on during turn on phase of the opposite IGBT. A Miller clamp allows sinking the Miller current across a low impedance path in this high dV/dt situation. Therefore in many applications, the use of a negative supply voltage can be avoided. During turn-off, the gate voltage is monitored and the clamp output is activated when the gate voltage drops below typical 2 V (referred to $VEE2$). The clamp is designed for a Miller current in the same range as the nominal output current.

4 Functional description

4.3 Non-inverting and inverting inputs

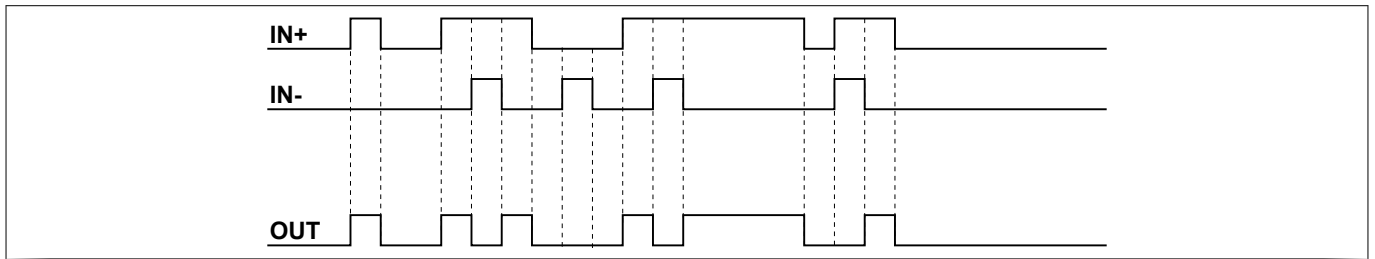

Figure 9 Logic input to output switching behavior

There are two possible input modes to control the IGBT. At non-inverting mode $IN+$ controls the driver output while $IN-$ is set to low. At inverting mode $IN-$ controls the driver output while $IN+$ is set to high. A minimum input pulse width is defined to filter occasional glitches.

4.4 Driver outputs

The output driver section uses MOSFETs to provide a rail-to-rail output. This feature permits that tight control of gate voltage during on-state and short circuit can be maintained as long as the driver's supply is stable. Due to the low internal voltage drop, switching behavior of the IGBT is predominantly governed by the gate resistor. Furthermore, it reduces the power to be dissipated by the driver.

5 Electrical characteristics and parameters

5 Electrical characteristics and parameters

5.1 Absolute maximum ratings

Absolute maximum ratings are defined as ratings, which when being exceeded may lead to destruction of the integrated circuit. Unless otherwise noted all parameters refer to GND1.

Table 4 Absolute maximum ratings

Parameter	Symbol	Values		Unit	Note or test condition
		Min.	Max.		
Input to output offset voltage	V_{OFFSET}	–	2300	V	$V_{\text{VEE2,max}} - V_{\text{VEE2,min}}$ with $V_{\text{VEE2,max}} \geq V_{\text{GND1}} \geq V_{\text{VEE2,min}}$ ^{1) 2)}
Power supply output side	V_{VCC2}	-0.3	40	V	³⁾
Gate driver output ($OUT+$, $OUT-$, OUT , $CLAMP$)	V_{OUT}	$VEE2 - 0.3$	$VCC2 + 0.3$	V	³⁾
Power supply input side	V_{VCC1}	-0.3	17	V	$VCC1 - GND1$
Logic input voltages ($IN+$, $IN-$)	V_{IN}	-0.3	6.5	V	$IN - GND1$
Junction temperature	T_J	-40	150	°C	–
Storage temperature	T_{Stg}	-55	150	°C	–
Power dissipation (input side)	$P_{\text{D,IN}}$	–	100	mW	$T_A = 65^\circ\text{C}$ ⁴⁾
Power dissipation (output side)	$P_{\text{D,OUT}}$	–	500	mW	$T_A = 65^\circ\text{C}$ ⁵⁾
Thermal resistance junction to ambient	$R_{\text{thJA,OUT}}$	–	151	K/W	$T_A = 85^\circ\text{C}$ 150 mil, 1s0p, $P_J = 500$ mW
Characterization parameter junction to package top input side	Ψ_{Jtop}	–	3.3	K/W	
ESD robustness	$V_{\text{ESD,HBM}}$	–	4	kV	Human body model ⁶⁾
	ESD,CDM	–	TC 1000	–	Charged device model ⁷⁾

- 1) for functional operation only
- 2) See also Chapter 6 on page 16
- 3) With respect to VEE2
- 4) IC input-side power dissipation is derated linearly with 6.6 mW/°C above 135 °C
- 5) IC output-side power dissipation is derated linearly with 6.6 mW/°C above 74 °C
- 6) According to ANSI/ESDA/JEDEC-JS-001-2017 (discharging a 100 pF capacitor through a 1.5 kΩ series resistor).
- 7) According to ANSI/ESDA/JEDEC-JS-002-2014 (TC = test condition in volt)

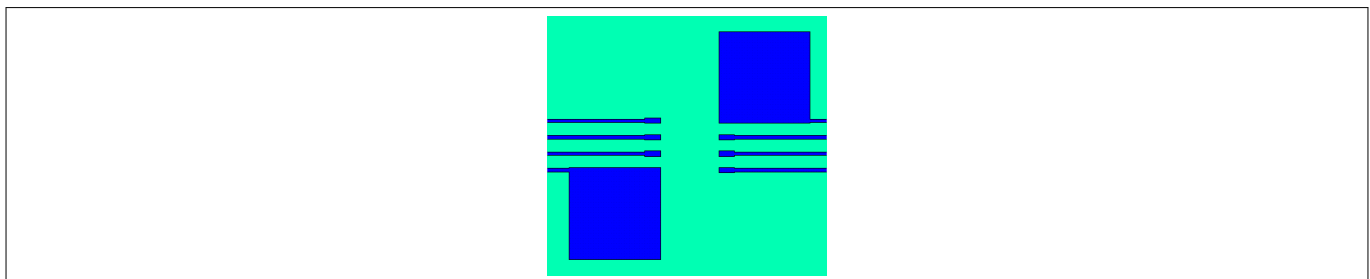

Figure 10 Reference layout for thermal data (Copper thickness 35 μm)

This PCB layout represents the reference layout used for the thermal characterization of the 150 mil package.

5 Electrical characteristics and parameters

5.2 Operating parameters

Within the operating range the IC operates as described in the functional description. Unless otherwise noted all parameters refer to *GND1*.

Table 5 Electrical characteristics

Parameter	Symbol	Values		Unit	Note or test condition
		Min.	Max.		
Power supply output side	V_{VCC2}	10	35	V	1)
Power supply input side	V_{VCC1}	3.1	15	V	–
Logic input voltages ($IN+$, $IN-$)	V_{IN}	-0.3	5.5	V	–
Switching frequency	f_{SW}	–	1	MHz	max P_D applies
Ambient temperature	T_A	-40	125	°C	–
Common mode transient immunity (CMTI)	CMTI	-200	200	kV/ μ s	$V_{OFFSET, test} = 1500$ V

1) With respect to *VEE2*

5 Electrical characteristics and parameters

5.3 Electrical characteristics

Note: The electrical characteristics include the spread of values in supply voltages, load and junction temperatures given below. Typical values represent the median values at $T_A = 25^\circ\text{C}$. Unless otherwise noted all voltages are given with respect to their respective GND (GND1 for pins 1 to 3 and VEE2 for pins 5 to 7).

5.3.1 Power supply

Table 6 Power supply

Parameter	Symbol	Values			Unit	Note or test condition
		Min.	Typ.	Max.		
UVLO threshold input side (on)	V_{UVLOH1}	–	–	3.1	V	–
UVLO threshold input side (off)	V_{UVLOL1}	2.5	–	–	V	–
UVLO hysteresis input side	V_{HYS1}	0.1	0.2	–	V	–
UVLO threshold output side (on)	$V_{UVLOH2,1}$	–	–	12.5	V	1ED3124MU12F, 1ED3125MU12F
UVLO threshold output side (off)	$V_{UVLOL2,1}$	10.5	–	–	V	
UVLO threshold output side (on)	$V_{UVLOH2,2}$	–	–	14.2	V	1ED3127MU12F
UVLO threshold output side (off)	$V_{UVLOL2,2}$	12.0	–	–	V	
UVLO hysteresis output side	V_{HYS2}	0.8	–	–	V	–
Quiescent current input side	I_{Q1}	–	–	1.1	mA	static, output low
Quiescent current output side	I_{Q2}	–	–	2	mA	
Start up time	t_{START}	–	2.5	20	μs	1)
UVLO detection filter time	t_{UVLOft}	50	–	–	ns	1)

1) Parameter is not subject to production test - verified by design/characterization

5.3.2 Logic input

Table 7 Logic input

Parameter	Symbol	Values			Unit	Note or test condition
		Min.	Typ.	Max.		
$IN+$, $IN-$ logic low input voltage	$V_{IN,L}$	–	–	1.1	V	–
$IN+$, $IN-$ logic high input voltage	$V_{IN,H}$	2.5	–	–	V	–
$IN+$, $IN-$ low/high hysteresis	$V_{IN,HYS}$	0.5	0.8	–	V	–
$IN+$, $IN-$ input current	I_{IN}	–	–	100	μA	$V_{VCC1} = 5\text{ V}; V_{IN} \leq V_{VCC1}$
$IN+$ pull down resistor	$R_{IN,PD}$	–	75	–	k Ω	to GND1
$IN-$ pull up resistor	$R_{IN,PU}$	–	75	–	k Ω	ensures high-level detection with unconnected pin

5 Electrical characteristics and parameters

5.3.3 Gate driver

All gate driver output parameters valid for $V_{CC2} = 15\text{ V}$ supply voltage unless specified otherwise.

Table 8 Gate driver

Parameter	Symbol	Values			Unit	Note or test condition
		Min.	Typ.	Max.		
1ED3125MU12F, 1ED3127MU12F						
High level output peak current	$I_{OUT,H}$	4.0	10.0	–	A	¹⁾ $V_{CC2-OUT} = 15\text{ V}$, Output on
High level output on resistance	$R_{DSON,H}$	0.26	0.50	0.85	Ω	$I_{OUT,H} = 0.1\text{ A}$
Low level output peak current	$I_{OUT,L}$	4.0	9.0	–	A	¹⁾ $OUT-VEE2 = 15\text{ V}$, Output off
Low level output on resistance	$R_{DSON,L}$	0.23	0.38	0.65	Ω	$I_{OUT,L} = 0.1\text{ A}$
Low level clamp peak current	$I_{CLAMP,L}$	2.0	3.0	–	A	¹⁾ $V_{CLAMP} = 2.0\text{ V}$
Low level clamp on resistance	$R_{DSON,CLP}$	0.26	0.45	0.75	Ω	$I_{OUT,L} = 0.1\text{ A}$
CLAMP threshold voltage	V_{CLAMP}	1.6	2.0	2.4	V	CLAMP-VEE2
CLAMP comparator to CLAMP activation delay time	t_{CLPDLY}	–	–	80	ns	¹⁾ $V_{CLAMP} \leq 2.0\text{ V}$
1ED3124MU12F						
High level output peak current	$I_{OUT,H}$	6.0	13.5	–	A	¹⁾ $V_{CC2-OUT+} = 15\text{ V}$, Output on
High level output on resistance	$R_{DSON,H}$	0.26	0.38	0.65	Ω	$I_{OUT,H} = 0.1\text{ A}$
Low level output peak current	$I_{OUT,L}$	6.0	14.0	–	A	¹⁾ $OUT-VEE2 = 15\text{ V}$, Output off
Low level output on resistance	$R_{DSON,L}$	0.21	0.28	0.6	Ω	$I_{OUT,L} = 0.1\text{ A}$
all variants						
High level output voltage	$\Delta V_{OUT,H}$	–	–	0.3	V	$V_{CC2}-V_{OUT,H}$; $I_{OUT} = 20\text{ mA}$
Low level output voltage	$\Delta V_{OUT,L}$	–	–	0.1	V	$V_{CC2}-V_{OUT,H}$; $I_{OUT} = 20\text{ mA}$
Short circuit clamp voltage between $OUT+/CLAMP$ and V_{CC2}	V_{CLP}	–	–	2.0	V	Output on, $I_{OUT} = 500\text{ mA}$, $t < 10\text{ }\mu\text{s}$

1) Parameter is not subject to production test - verified by design/characterization

5.3.4 Dynamic characteristics

Dynamic characteristics are measured with $V_{VCC1} = 5\text{ V}$ and $V_{VCC2} = 15\text{ V}$.

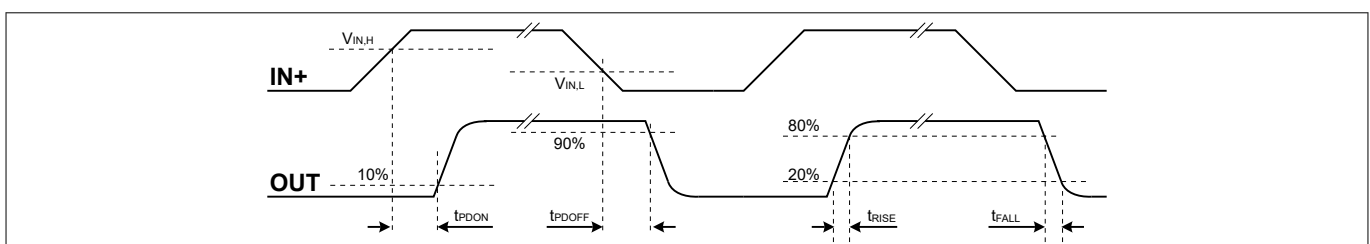

Figure 11 Propagation delay, rise and fall time

5 Electrical characteristics and parameters

Table 9 Filter and propagation delay characteristics (all other variants)

Parameter	Symbol	Values			Unit	Note or test condition
		Min.	Typ.	Max.		
Input to output propagation delay ON	t_{PDON}	80	90	100	ns	$C_{LOAD} = 100 \text{ pF}$, I_N turn-on threshold to 10% output on
Input to output propagation delay OFF	t_{PDOFF}	80	90	100	ns	$C_{LOAD} = 100 \text{ pF}$, I_N turn-off threshold to 90% output off
Input to output propagation delay distortion	t_{PDISTO}	-5	0	5	ns	$t_{PDOFF} - t_{PDON}$
Input pulse suppression time (filter time)	t_{INFLT}	30	-	-	ns	shorter pulses will not propagate to the output
Minimum input pulse length	t_{MININ}	-	-	40	ns	-
Input to output propagation delay variation due to temperature	$t_{PD,T}$	-	-	14	ns	¹⁾
Input to output propagation delay distortion variation due to temperature	$t_{PDISTO,T}$	-	-	3	ns	¹⁾
Input to output, part to part propagation delay ON variation	$ t_{PDON,P2P} $	-	-	7	ns	^{1) 2)} $C_{LOAD} = 100 \text{ pF}$

1) Parameter is not subject to production test - verified by design/characterization

2) Absolute value at same ambient and operating conditions.

Table 10 Dynamic output characteristics

Parameter	Symbol	Values			Unit	Note or test condition
		Min.	Typ.	Max.		
Rise time	t_{RISE}	-	-	15	ns	$C_{LOAD} = 100 \text{ pF}$
Fall time	t_{FALL}	-	-	15	ns	$C_{LOAD} = 100 \text{ pF}$
Rise time	t_{RISE}	-	-	30	ns	$C_{LOAD} = 1 \text{ nF}$
Fall time	t_{FALL}	-	-	30	ns	$C_{LOAD} = 1 \text{ nF}$

5.3.5 Active shut down

Table 11 Active shut down

Parameter	Symbol	Values			Unit	Note or test condition
		Min.	Typ.	Max.		
Active shut down voltage, cold	$V_{ACTSD,C}$	-	-	1.9	V	$I_{OUT} = 10 \text{ mA}$; V_{CC2} un-supplied; $T_A < 20^\circ\text{C}$
Active shut down voltage, hot	$V_{ACTSD,H}$	-	-	1.7	V	¹⁾ $I_{OUT} = 10 \text{ mA}$; V_{CC2} un-supplied; $T_A \geq 20^\circ\text{C}$

1) Parameter is not subject to production test - verified by design/characterization

6 Insulation characteristics

6 Insulation characteristics

Table 12 Safety limiting values

This coupler is suitable for rated insulation only within the given safety limiting values. Compliance with the safety limiting values shall be ensured by means of suitable protective circuits.

Description	Symbol	Characteristic	Unit
Maximum ambient safety temperature	T_S	150	°C
Maximum input-side power dissipation at $T_A = 25^\circ\text{C}^{1)}$	P_{SI}	100	mW
Maximum output-side power dissipation at $T_A = 25^\circ\text{C}^{2)}$	P_{SO}	717	mW

1) IC input-side power dissipation is derated linearly with 6.6 mW/°C above 135 °C

2) IC output-side power dissipation is derated linearly with 5.7 mW/°C above 25°C

Table 13 Package specific insulation characteristics

Description	Symbol	Characteristic	Unit
Minimum external clearance	CLR	>4	mm
Minimum external creepage	CPG	>4	mm
Minimum comparative tracking index	CTI	600	-
Insulation capacitance	C_{I0}	0.9	pF

6.1 Recognized under UL 1577 (File E311313)

Table 14 Recognized under UL 1577

Description	Symbol	Characteristic	Unit
Insulation Withstand Voltage / 1 min	V_{ISO}	3000	V (rms)
Insulation Test Voltage / 1 s	$V_{ISO,TEST}$	3600	V (rms)

7 Package dimensions

7 Package dimensions

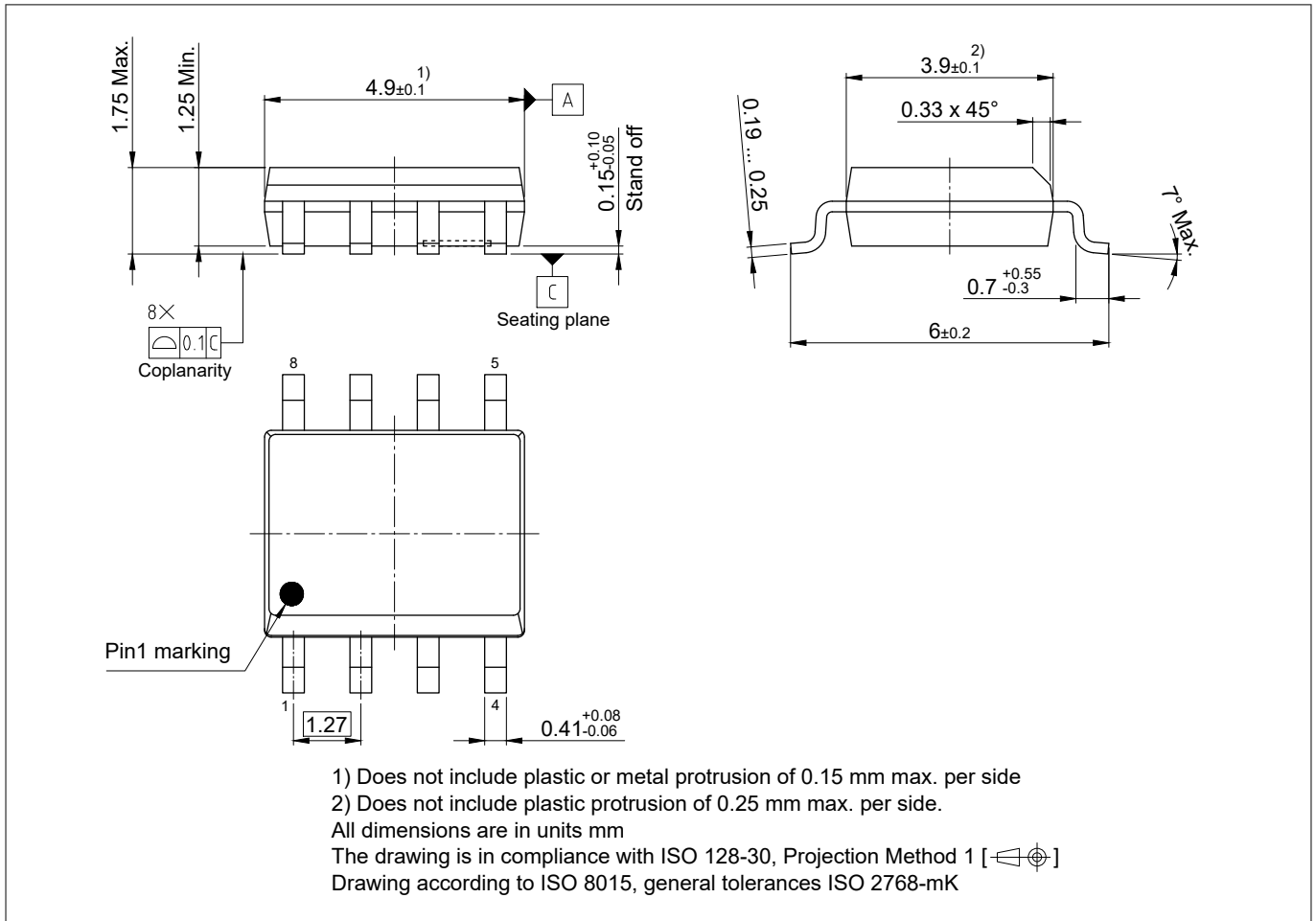

Figure 12 PG-DSO-8 (Plastic (green) dual small outline package, 150 mil)

Revision history

Reference	Description
v2.0 (2021-02-23)	Final datasheet based on 1ED31xxMU12H
(2021-09-01)	New version number schema: Target/Preliminary datasheet: 0.XY; Final datasheet: 1.XY
1.10 (2021-10-11)	Product variant and related electrical characteristics added, related products updated, package marking added, package rendering updated
1.20 (2022-08-09)	Correction of thermal related parameters Added new product variant and related electrical characteristics
1.30 (2023-06-26)	adding package specific insulation characteristics

Trademarks

All referenced product or service names and trademarks are the property of their respective owners.

Edition 2023-06-26

Published by

Infineon Technologies AG

81726 Munich, Germany

© 2023 Infineon Technologies AG

All Rights Reserved.

Do you have a question about any aspect of this document?

Email: erratum@infineon.com

Document reference

IFX-xgd1587538263084

Important notice

The information given in this document shall in no event be regarded as a guarantee of conditions or characteristics ("Beschaffheitsgarantie").

With respect to any examples, hints or any typical values stated herein and/or any information regarding the application of the product, Infineon Technologies hereby disclaims any and all warranties and liabilities of any kind, including without limitation warranties of non-infringement of intellectual property rights of any third party.

In addition, any information given in this document is subject to customer's compliance with its obligations stated in this document and any applicable legal requirements, norms and standards concerning customer's products and any use of the product of Infineon Technologies in customer's applications.

The data contained in this document is exclusively intended for technically trained staff. It is the responsibility of customer's technical departments to evaluate the suitability of the product for the intended application and the completeness of the product information given in this document with respect to such application.



Warnings

Due to technical requirements products may contain dangerous substances. For information on the types in question please contact your nearest Infineon Technologies office.

Except as otherwise explicitly approved by Infineon Technologies in a written document signed by authorized representatives of Infineon Technologies, Infineon Technologies' products may not be used in any applications where a failure of the product or any consequences of the use thereof can reasonably be expected to result in personal injury.

Looking for pricing, stock, or lifecycle information?

Click below to explore more details on WIN SOURCE:

-  [View 1ED3125MU12FXUMA1 on WIN SOURCE](#)
-  [Infineon Technologies Information](#)

Optimize Your Supply Chain with WIN SOURCE Solutions

-  Global Sourcing Solution
-  Obsolete Management
-  Cost Control Management
-  Shortage Management
-  Alternative Solution
-  Excess Inventory Management