



**THE DATASHEET OF
1ED44175N01BXTSA1**



1ED44175N01B

Single-channel low-side IGBT gate driver IC with over-current protection

Features

- Over-current detection with negative voltage input
- -0.246 V over-current threshold with accurate $\pm 5\%$ tolerance
- Single pin for fault output and enable
- Programmable fault clear time
- Under voltage lockout for IGBTs
- CMOS Schmitt-triggered inputs
- 3.3 V, 5 V and 15 V input logic compatible
- 25 V V_{CC} voltage supply support (max)
- Output in phase with input
- -10 Vdc negative Input capability of OCP pin
- 3 kV ESD HBM
- RoHS compliant

Potential applications

- Digitally controlled PFC
- Home appliances
- Air conditioner
- Industrial applications
- General purpose low-side gate driver for single-ended topologies



Description

The 1ED44175N01B is a low-voltage, power IGBT, non-inverting gate driver. Proprietary latch-up immune CMOS technologies enable ruggedized monolithic construction. The logic input is compatible with standard CMOS or LSTTL output. The output driver features a current buffer stage. The 1ED44175N01B has OCP pin for over current protection sense and a FAULT status output (when activated, EN/\overline{FLT} pin is internally pulled down). The EN/\overline{FLT} needs to be externally pulled up to provide normal operation, pulling EN/\overline{FLT} low disable the driver. Internal circuitry on V_{CC} pin provides an under voltage lockout protection that holds output low until V_{CC} supply voltage is within operating range.

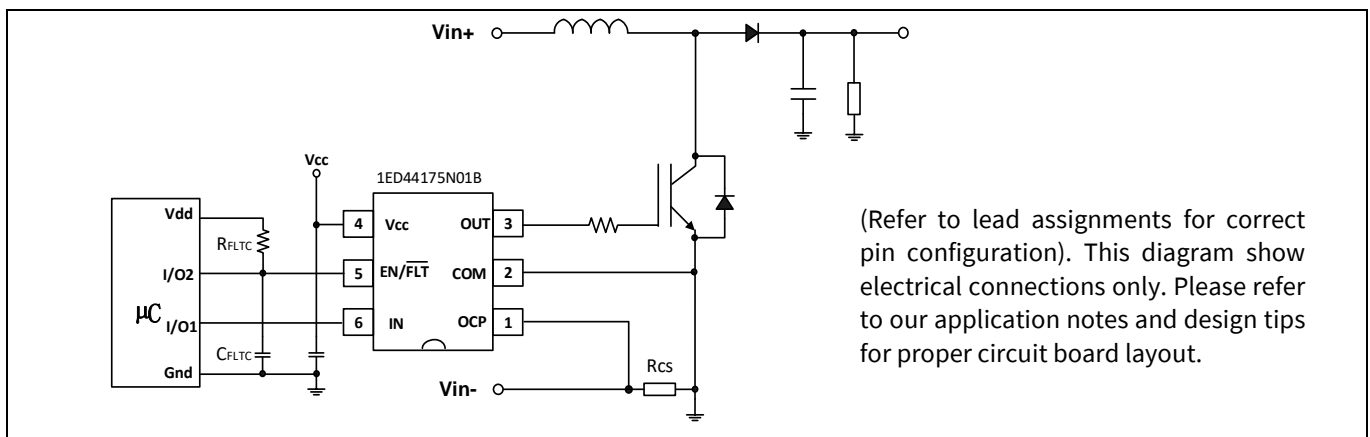

Figure 1 Typical application

Ordering information

Product type	Package	Standard pack		Orderable part number
		Form	Quantity	
1ED44175N01B	PG-SOT23-6-3	Tape and Reel	3000	1ED44175N01BXTSA1

Product validation

Qualified for industrial applications according to the relevant tests of JEDEC JESD47/22 and J-STD-020.

Table of contents

1	Block diagram	3
2	Pin configuration and functionality	4
2.1	Pin configuration.....	4
2.2	Input/output logic truth table.....	5
3	Qualification information	6
4	Electrical parameters	7
4.1	Absolute maximum ratings.....	7
4.2	Recommended operating conditions.....	7
4.3	Static electrical characteristics.....	8
4.4	Dynamic electrical characteristics.....	8
5	Application information and additional details	9
5.1	IGBT gate driver.....	9
5.2	Switching and timing relationships.....	9
5.3	Input logic compatibility.....	10
5.4	Undervoltage lockout (V _{CC}).....	10
5.5	Over current protection (OCP).....	11
5.6	Fault reporting and programmable fault clear timer.....	12
5.7	Enable input.....	12
6	Package outline: PG-SOT23-6-3	13
7	Tape and reel details	14
8	Part marking information	15
9	Similar products	16
10	Related documents	17
	Revision history	18

1 Block diagram

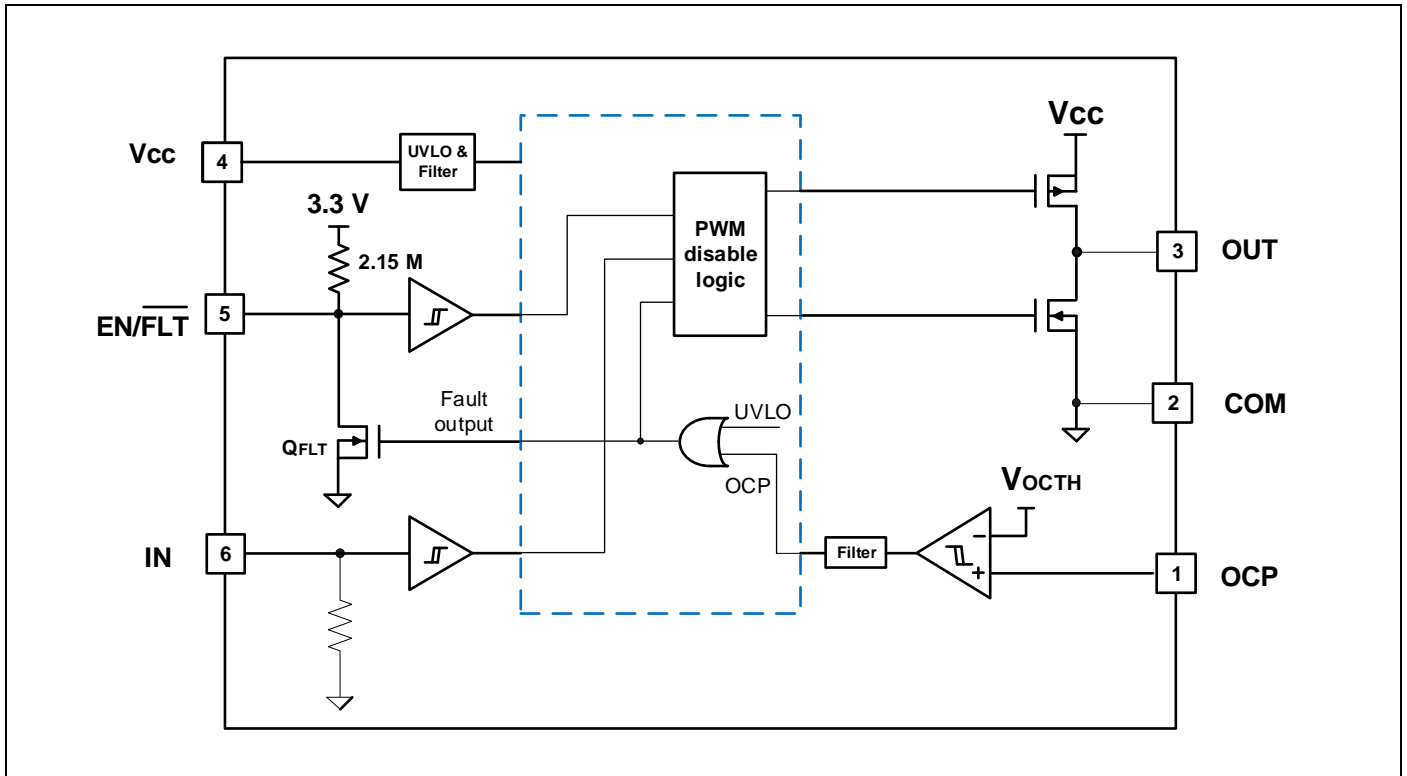

Figure 2 Block diagram

2 Pin configuration and functionality

2.1 Pin configuration

Table 1 Pin configuration

Pin no.	Name	Function
1	OCP	Current sense input
2	COM	Ground
3	OUT	Gate drive output
4	Vcc	Supply Voltage
5	EN/ $\overline{\text{FLT}}$	Enable, fault reporting and fault clear time program pin, three functions: <ol style="list-style-type: none"> 1. Logic input to enable I/O functionality. I/O logic functions when ENABLE is high. 2. Fault reporting function like over-current or undervoltage lockout, this pin has negative logic and an open-drain output. 3. Fault clear time program with external resistor and capacitor.
6	IN	Logic input for gate driver output (OUT), in phase

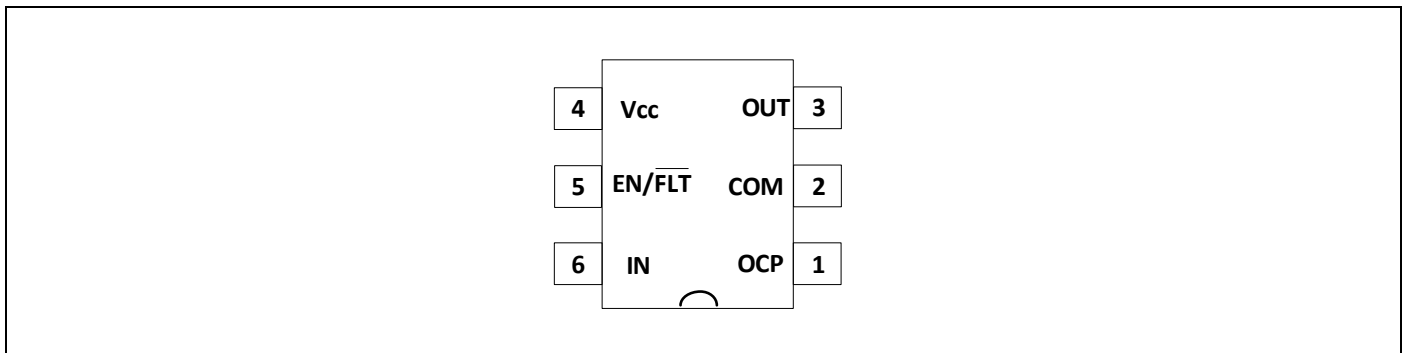

Figure 3 PG-SOT23-6-3 (top view)

2.2 Input/output logic truth table

Table 2 Input/output logic truth table

IN	UVLO ¹⁾	OCP ²⁾	EN/ $\overline{\text{FLT}}$ ³⁾	OUT	Note
L	H	L	H	L	OUT = L
H	H	L	H	H	OUT = H
X	L	X	L	L	OUT = L, EN/ $\overline{\text{FLT}}$ = L, (UVLO protection will disable input signals until EN/ $\overline{\text{FLT}}$ returns to high level.)
X	H	H	L	L	OUT = L, EN/ $\overline{\text{FLT}}$ = L, (Over current protection will disable input signals until EN/ $\overline{\text{FLT}}$ returns to high level.)
X	H	X	L	L	OUT = L (Externally pull down EN/ $\overline{\text{FLT}}$ pin will disable I/O logic until EN/ $\overline{\text{FLT}}$ returns to high level.)

1) UVLO "L" state is under-voltage protection.

2) OCP "H" state is over-current protection.

3) EN/ $\overline{\text{FLT}}$ "H" state is EN/ $\overline{\text{FLT}}$ pin externally pulling up and internally pull down MOSFET (Q_{FLT}) is off. (See Block Diagram.)

3 Qualification information

Qualification level		Industrial ¹⁾
		Comments: This family of ICs has passed JEDEC's Industrial qualification. Consumer qualification level is granted by extension of the higher Industrial level.
Moisture sensitivity level		MSL1 ²⁾ 260°C (per JEDEC standard J-STD-020)
ESD	Charged device model	1.5 kV (per ANSI/ESDA/JEDEC standard JS-002)
	Human body model	3 kV (per ANSI/ESDA/JEDEC standard JS-001)
IC latch-up test		Class II, Level A (per JESD78)
RoHS compliant		Yes

- 1) Higher qualification ratings may be available should the user have such requirements. Please contact your Infineon sales representative for further information.
- 2) Higher MSL ratings may be available for the specific package types listed here. Please contact your Infineon sales representative for further information.

4 Electrical parameters

4.1 Absolute maximum ratings

Absolute maximum ratings indicate sustained limits beyond which damage to the device may occur. The device may not function or not be operable above the recommended operating conditions and stressing the parts to these levels is not recommended. In addition, extended exposure to stresses above the recommended operating conditions may affect device reliability. All voltage parameters are absolute voltages referenced to COM. The thermal resistance and power dissipation ratings are measured under board mounted and still air conditions.

Table 3 Absolute maximum ratings

Symbol	Definition	Min	Max	Units
V_{CC}	Fixed supply voltage	- 0.3	25	V
V_O	Output voltage (OUT)	- 0.3	$V_{CC} + 0.3$	
V_{OCP}	Voltage at current sense pin (OCP)	- 10	$V_{CC} + 0.3$	
$V_{EN/\overline{FLT}}$	Voltage at enable and fault reporting pin (EN/\overline{FLT})	- 0.3	$V_{CC} + 0.3$	
V_{IN}	Logic input voltage (IN)	- 10	$V_{CC} + 0.3$	
P_D	Package power dissipation @ $T_A \leq 25^\circ\text{C}$	—	0.5	W
R_{thJA}	Thermal resistance, junction to ambient	PG-SOT23-6	250	$^\circ\text{C}/\text{W}$
T_J	Junction temperature	- 40	150	$^\circ\text{C}$
T_S	Storage temperature	- 55	150	
T_L	Lead temperature (soldering, 10 seconds)	—	260	

4.2 Recommended operating conditions

For proper operation, the device should be used within the recommended conditions. All voltage parameters are absolute voltages referenced to COM unless otherwise stated in the table.

Table 4 Recommended operating conditions

Symbol	Definition	Min	Max	Units
V_{CC}	Fixed supply voltage	12.7	20	V
V_O	Output voltage	COM	V_{CC}	
V_{OCP}	Voltage at current sense pin (OCP)	-5	V_{CC}	
$V_{EN/\overline{FLT}}$	Voltage at enable and fault reporting pin (EN/\overline{FLT})	0	V_{CC}	
V_{IN}	Logic input voltage (IN)	- 5	V_{CC}	
T_A	Ambient temperature	- 40	125	$^\circ\text{C}$

4.3 Static electrical characteristics

$V_{CC} = 15V$, $T_A = 25^\circ C$ unless otherwise specified. The V_{INL} , V_{INH} , V_{ENL} , V_{ENH} , V_{OCTH} , and I_{IN} , I_{FLT} parameters are referenced to COM and are applicable to input leads: IN, OCP and EN/ \overline{FLT} . The V_O and I_O parameters are referenced to COM and are applicable to the output lead: OUT.

Table 5 Static electrical characteristics

Symbol	Definition	Min	Typ	Max	Units	Test Conditions
V_{CCUV+}	Vcc supply undervoltage positive going threshold	11.2	11.9	12.7	V	
V_{CCUV-}	Vcc supply undervoltage negative going threshold	10.3	11	11.8		
V_{CCUVH}	Vcc supply undervoltage lockout hysteresis	—	0.9	—		
V_{INL}	Logic “0” input voltage (OUT = LO)	0.8	1.0	1.2		
V_{INH}	Logic “1” input voltage (OUT = HI)	1.9	2.1	2.3		
V_{ENL}	Logic “0” disable voltage	0.8	1.0	1.2		
V_{ENH}	Logic “1” enable voltage	1.9	2.1	2.3		
V_{OH}	High level output voltage, $V_{CC} - V_{OUT}$	—	0.02	0.1		
V_{OL}	Low level output voltage, V_{OUT}	—	0.02	0.1	$I_O = 2 \text{ mA}$	
V_{OCTH}	Current limit threshold voltage	-259	-246	-233	mV	
I_{IN+}	Logic “1” input bias current IN pin	35	50	70	μA	$V_{IN} = 5 \text{ V}$
I_{IN-}	Logic “0” input bias current IN pin	-10	-6	—		$V_{IN} = 0 \text{ V}$
I_{OCC}	Quiescent V_{CC} supply current	—	700	1200	A	$V_{IN} = 0 \text{ V}$ or 5 V
I_{O+}	Output sourcing short circuit pulsed current	2	2.6	—		$V_O = 0 \text{ V}$, $PW \leq 2 \mu s$
I_{O-}	Output sinking short circuit pulsed current	2	2.6	—		$V_O = 15 \text{ V}$, $PW \leq 2 \mu s$
I_{FLT}	EN/ \overline{FLT} pull down sinking current	18	—	—	mA	$V_{EN/\overline{FLT}} = 0.4 \text{ V}$
V_{ACTSD}	Active shut down voltage	—	2.0	2.3	V	$V_{CC} = \text{open}$, $I_{OUT}/I_{O-} = 0.1$

4.4 Dynamic electrical characteristics

$V_{CC} = 15 \text{ V}$, $T_A = 25^\circ C$, and $C_L = 1000 \text{ pF}$ unless otherwise specified.

Table 6 Dynamic electrical characteristics

Symbol	Definition	Min	Typ	Max	Units	Test Conditions
t_{on}	Turn-on propagation delay	—	50	75	ns	Figure 6 V_{IN} pulse = 5 V
t_{off}	Turn-off propagation delay	—	50	75		
t_r	Turn-on rise time	—	5	—		
t_f	Turn-off fall time	—	5	—		
t_{DISA}	Disable propagation delay	—	50	75		Figure 12 V_{EN} pulse = 5 V
t_{OCPDEL}	Over current protection propagation delay	—	230	350		Figure 9, Figure 10 $R_{EN} = 10 \text{ k}\Omega$ to V_{CC} V_{OCP} pulse = - 0.5 V
t_{OCPFLT}	OCP to low level EN/ \overline{FLT} signal delay	—	200	320	μs	Figure 9, Figure 10 $V_{CC} = 3.3 \text{ V}$ $R_{FLTC} = 1 \text{ M}\Omega$ to Vdd, $C_{FLTC} = 150 \text{ pF}$ to COM
t_{FLTC}	FAULT clear time	80	103	130		
t_{BLK}	Over current protection blanking time	100	180	250		ns
t_{VCCUV}	V_{CC} supply UVLO filter time *	—	2	—	μs	Figure 8

*Parameter verified by design, not tested in production.

5 Application information and additional details

Information regarding the following topics is included as subsections within this section of the datasheet.

- IGBT gate driver
- Switching and timing relationships
- Input logic compatibility
- Undervoltage lockout protection
- Over current protection (OCP)
- Fault reporting and programmable fault clear timer
- Enable input

See the **1ED44175N01B application note AN2019-37** Low - side driver with over current protection and fault/enable (negative current sense) for interface circuit examples and recommended layout guidelines.

5.1 IGBT gate driver

The 1ED44175N01B is designed to drive IGBT power devices. Figure 4 and Figure 5 illustrate several parameters associated with the gate driver functionality of the driver. The output current of the driver, used to drive the gate of the power switch, is defined as I_o . The voltage that drives the gate of the external power switch is defined as V_{OUT} .

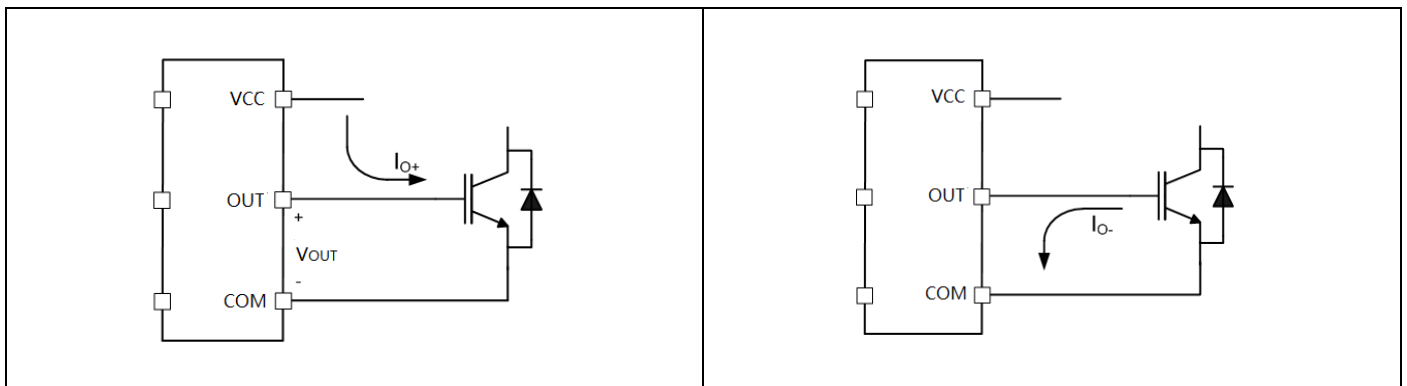

Figure 4 Gate output sourcing current

Figure 5 Gate output sinking current

5.2 Switching and timing relationships

The relationships between the input and output signals of the 1ED44175N01B are illustrated below Figure 6. From the figure, we can see the definitions of several timing parameters (i.e. t_{on} , t_{off} , t_r , and t_f) associated with this device.

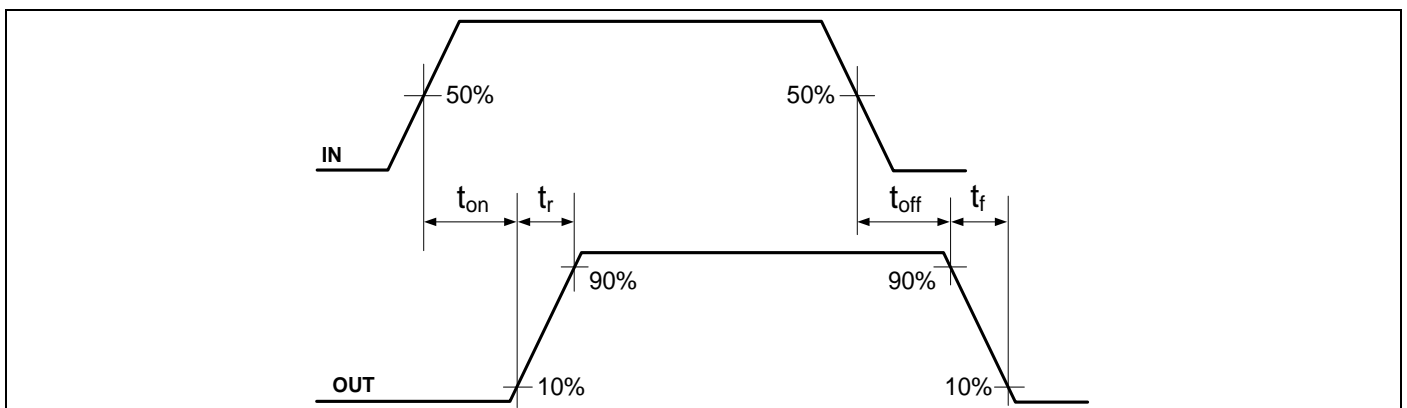

Figure 6 Switching time waveforms

5.3 Input logic compatibility

The input of this IC is compatible with standard CMOS and TTL outputs. The 1ED44175N01B has been designed to be compatible with 3.3 V, 5 V and 15 V logic-level signals. The input high threshold (V_{INH}) is typ. 2.1 V and low threshold (V_{INL}) is typ. 1 V. Input hysteresis offers enhanced noise immunity. The 1ED44175N01B includes an important feature: wherein, whenever the input pin is in a floating condition, the output is held in the low state. This is achieved using GND pull-down resistors on the input pin. Figure 7 illustrates an input signal to the 1ED44175N01B, its input threshold values, and the logic state of the IC as a result of the input signal.

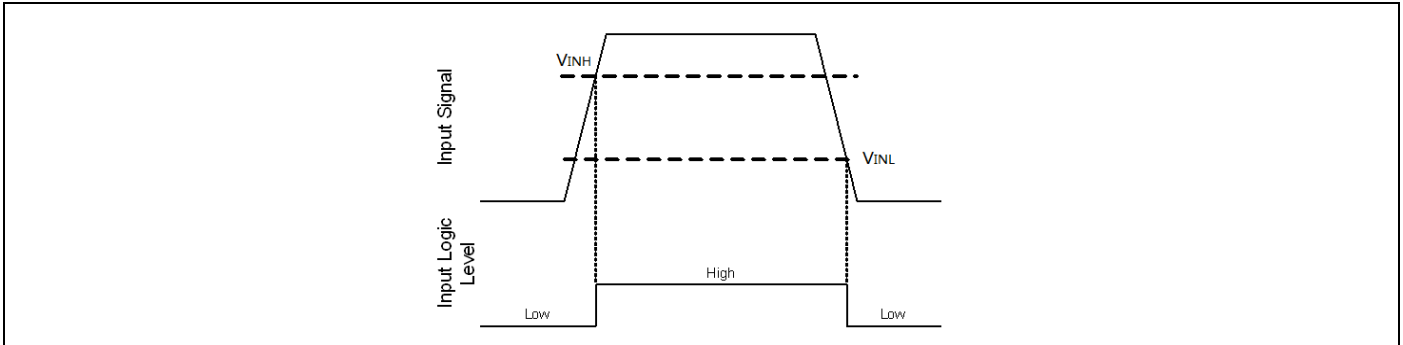

Figure 7 IN input thresholds

5.4 Undervoltage lockout (V_{CC})

The 1ED44175N01B has internal UVLO protection feature on the V_{CC} pin supply circuit blocks. When V_{CC} bias voltage keeps lower than the V_{CCUV-} threshold more than UVLO filter time (t_{VCCUV}), the V_{CC} UVLO feature holds the output low, regardless of the status of the IN input.

At the same time, the internal MOSFET Q_{FLT} turns on and the EN/\overline{FLT} pin is internally pulled down to COM. The EN/\overline{FLT} output stays in the low state until the UVLO has been removed; once the UVLO is removed, the internal MOSFET Q_{FLT} turns off, and the voltage on the EN/\overline{FLT} pin is charged up by external voltage V_{DD} . The length of the fault clear time period (t_{FLTc}) is determined by exponential charging characteristics of the capacitor where the time constant is set by R_{FLTc} and C_{FLTc} .

And when V_{CC} is higher than V_{CCUV+} and longer than fault clear time (t_{FLTc}), the OUT still keeps low until next input signal IN is high. (See Figure 8)

The filter time (t_{VCCUV}) of about 2 μ s helps to suppress noise from the UVLO circuit, so that negative going voltage spikes at the supply pin will avoid parasitic UVLO events.

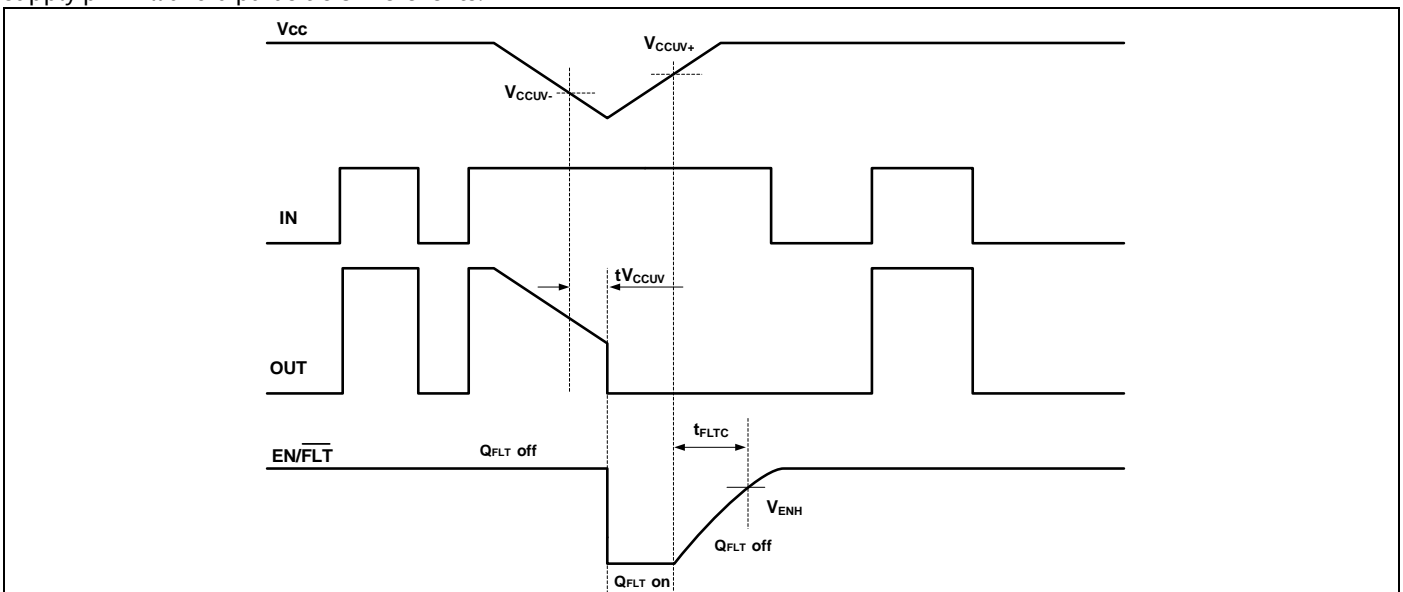

Figure 8 V_{CC} under voltage protection waveform definitions

5.5 Over current protection (OCP)

The 1ED44175N01B has a function of over current protection with a threshold V_{CSTH} at the OCP pin input. The voltage at this pin is the negative voltage drop sensed across the system current sense resistor. It is up to minus 10 VDC negative input capability of OCP pin. To avoid false tripping due to the fast high current switch on transient that occurs at the switch on of IGBT resulting from the circuit parasitic capacitors, there is a blanking interval which disables over current detection for the period of t_{BLK} (Additional RC filter is recommended, if internal t_{BLK} is not enough in the very noisy circuit.). After t_{BLK} and the voltage of OCP pin is over V_{CSTH} , the 1ED44175N01B causes fault logic to initiate a fault shutdown sequence. This sequence starts with the generation of a fault signal and internal MOSFET Q_{FLT} is turned on and EN/\overline{FLT} pin is pulled down.

At the same time the 1ED44175N01B terminates the present cycle, and the gate output is immediately pulled down with internal propagation delay (t_{OCPDEL}), see the Figure 9 and Figure 10.

Figure 9 is the diagram of 1ED44175N01B in boost application. And Figure 10 is the typical waveforms of the application. If the OCP fault condition is removed, the internal pull down NMOS of EN/\overline{FLT} is released and EN/\overline{FLT} will be pull up again with V_{dd} , but the output still keeps low until the next input signal IN is high.

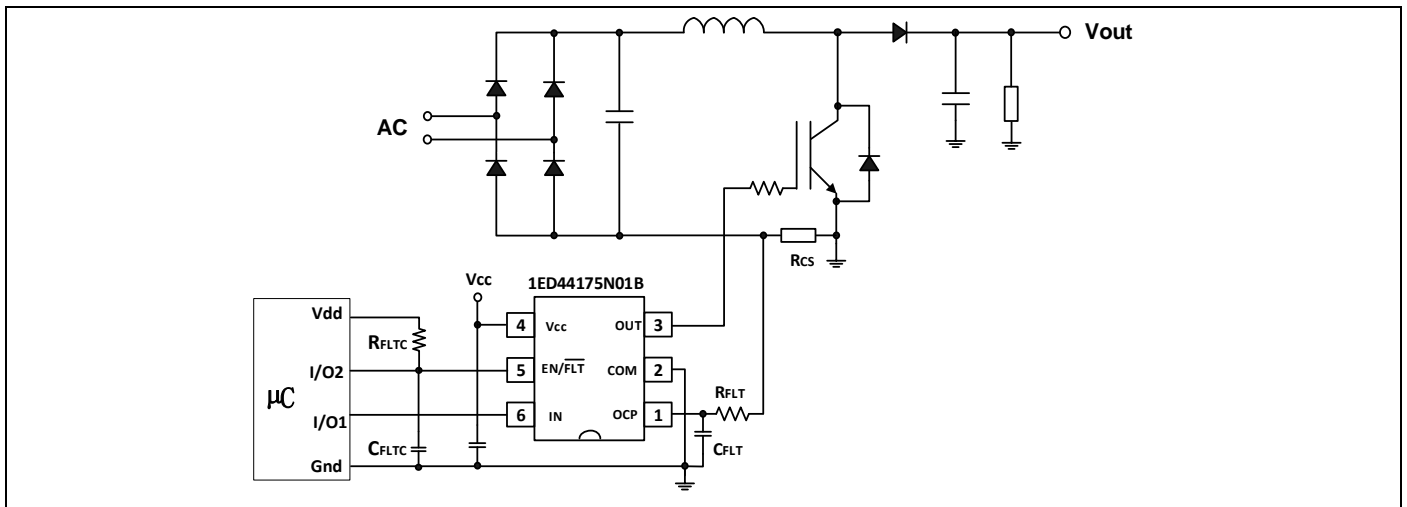

Figure 9 1ED44175N01B in Boost application

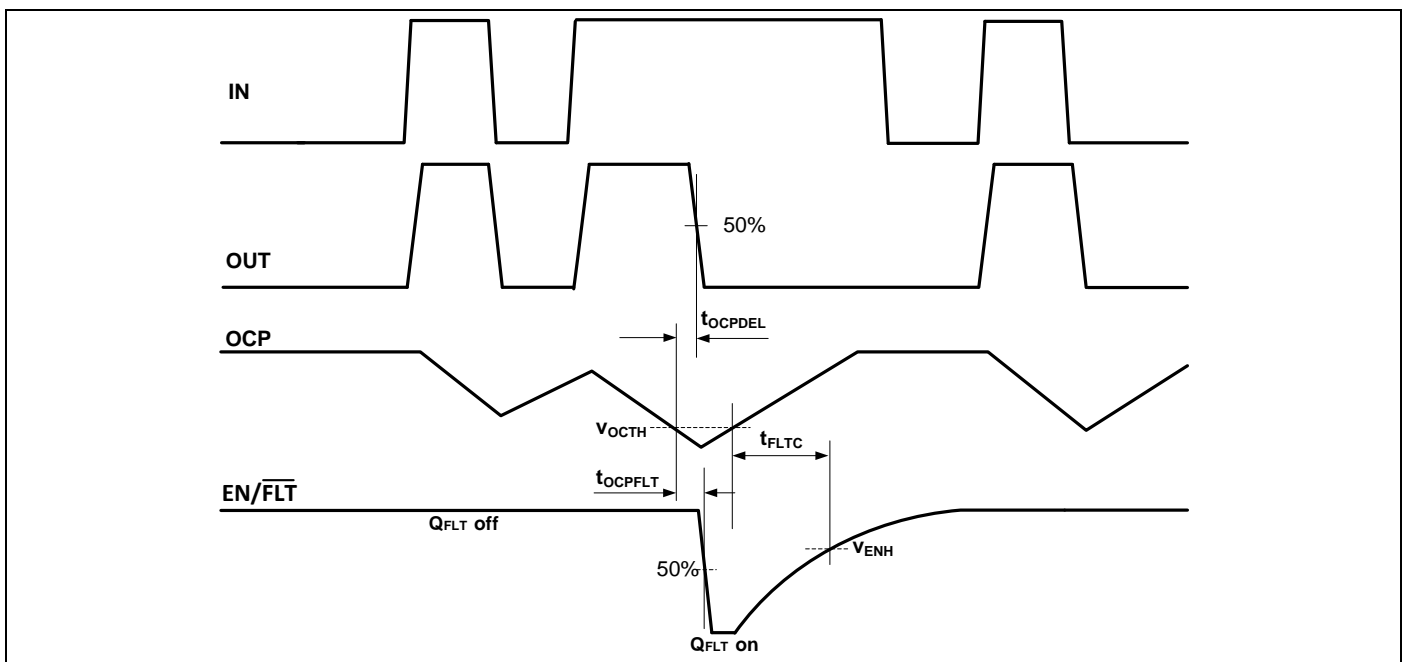

Figure 10 OCP fault detection and fault clear waveforms one

5.6 Fault reporting and programmable fault clear timer

The 1ED44175N01B provides an integrated fault reporting output and an adjustable fault clear timer. There are two situations that would cause the driver to report a fault via the EN/ $\overline{\text{FLT}}$ pin. The first is an under voltage condition of V_{CC} and the second is if the OCP pin recognizes a fault. Once the fault condition occurs, the EN/ $\overline{\text{FLT}}$ pin is internally pulled to COM. The EN/ $\overline{\text{FLT}}$ output stays in the low state until the fault condition has been removed and the internal pull down NMOS Q_{FLT} turns off, the voltage on the EN/ $\overline{\text{FLT}}$ pin is charged up with external pull-up voltage.

The length of the fault clear time period ($t_{\text{FLT C}}$) is determined by exponential charging characteristics of the capacitor where the time constant is set by $R_{\text{FLT C}}$ and $C_{\text{FLT C}}$. Figure 9 shows that $R_{\text{FLT C}}$ is connected between the external supply (V_{dd}) and the EN/ $\overline{\text{FLT}}$ pin, while $C_{\text{FLT C}}$ is placed between the EN/ $\overline{\text{FLT}}$ and COM pins. EN/ $\overline{\text{FLT}}$ is weakly pulled up to 3.3 V reference voltage with 2.15 M resistor internally. So the length of the fault clear time period can be determined by using the formula below (If $V_{\text{dd}} = 3.3 \text{ V}$).

$$t_{\text{FLT C}} = - \left(\frac{R_{\text{FLT C}} \times 2.15\text{M}}{R_{\text{FLT C}} + 2.15\text{M}} \right) \times C_{\text{FLT C}} \times \ln \left(1 - \frac{V_{\text{ENH}}}{V_{\text{dd}}} \right)$$

5.7 Enable input

1ED44175N01B provides an enable functionality that allows to shutdown or to enable the output. When EN/ $\overline{\text{FLT}}$ is pulled up (the enable voltage is higher than V_{ENH}) the output is able to operate normally, pulling EN/ $\overline{\text{FLT}}$ low (the enable voltage is lower than V_{ENL}) the output is disable. The relationships between the input, output and enable signals of the 1ED44175N01B are illustrated below in Figure 11~13. From these figures, we can see the definitions of several timing parameters and threshold voltages (i.e. t_{DISA} , V_{ENH} and V_{ENL}) associated with this device.

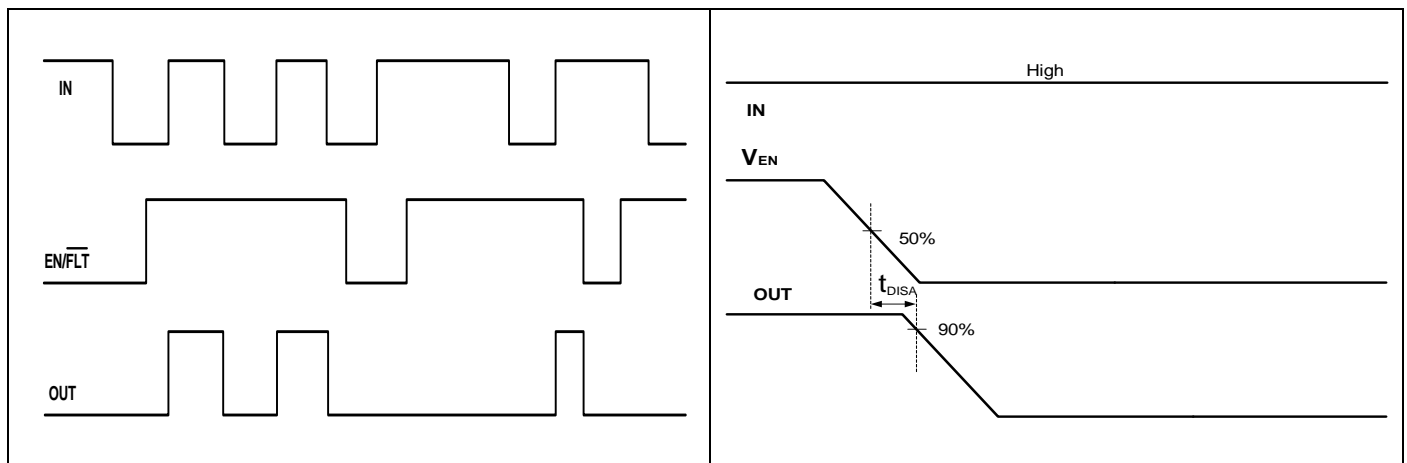

Figure 11 Input/output/enable pins timing diagram Figure 12 EN pin switching time waveform

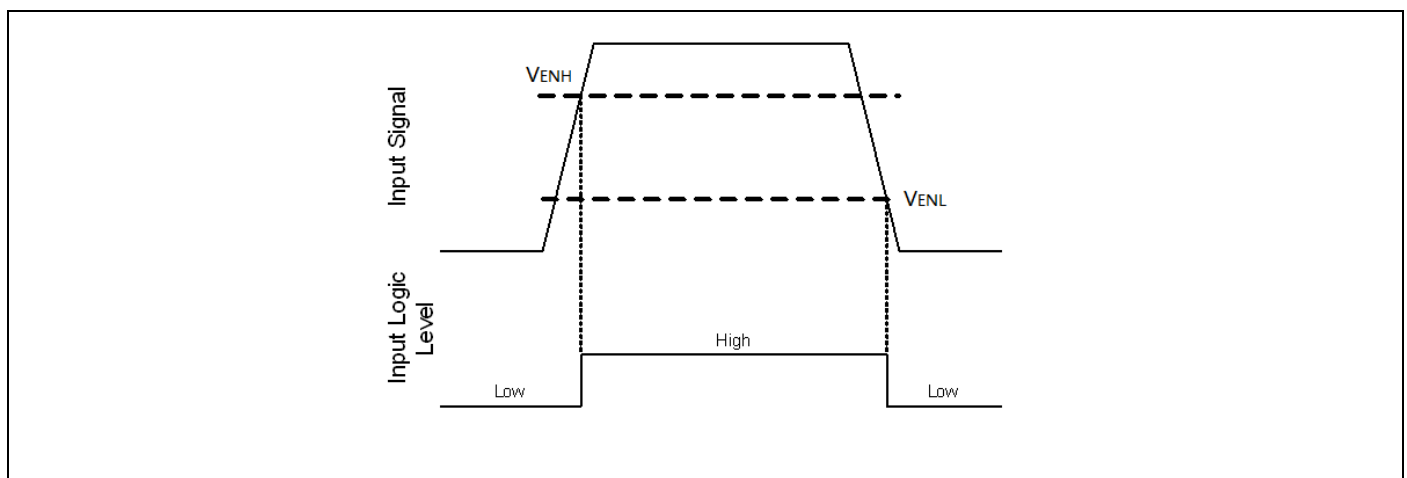

Figure 13 EN input thresholds

6 Package outline: PG-SOT23-6-3

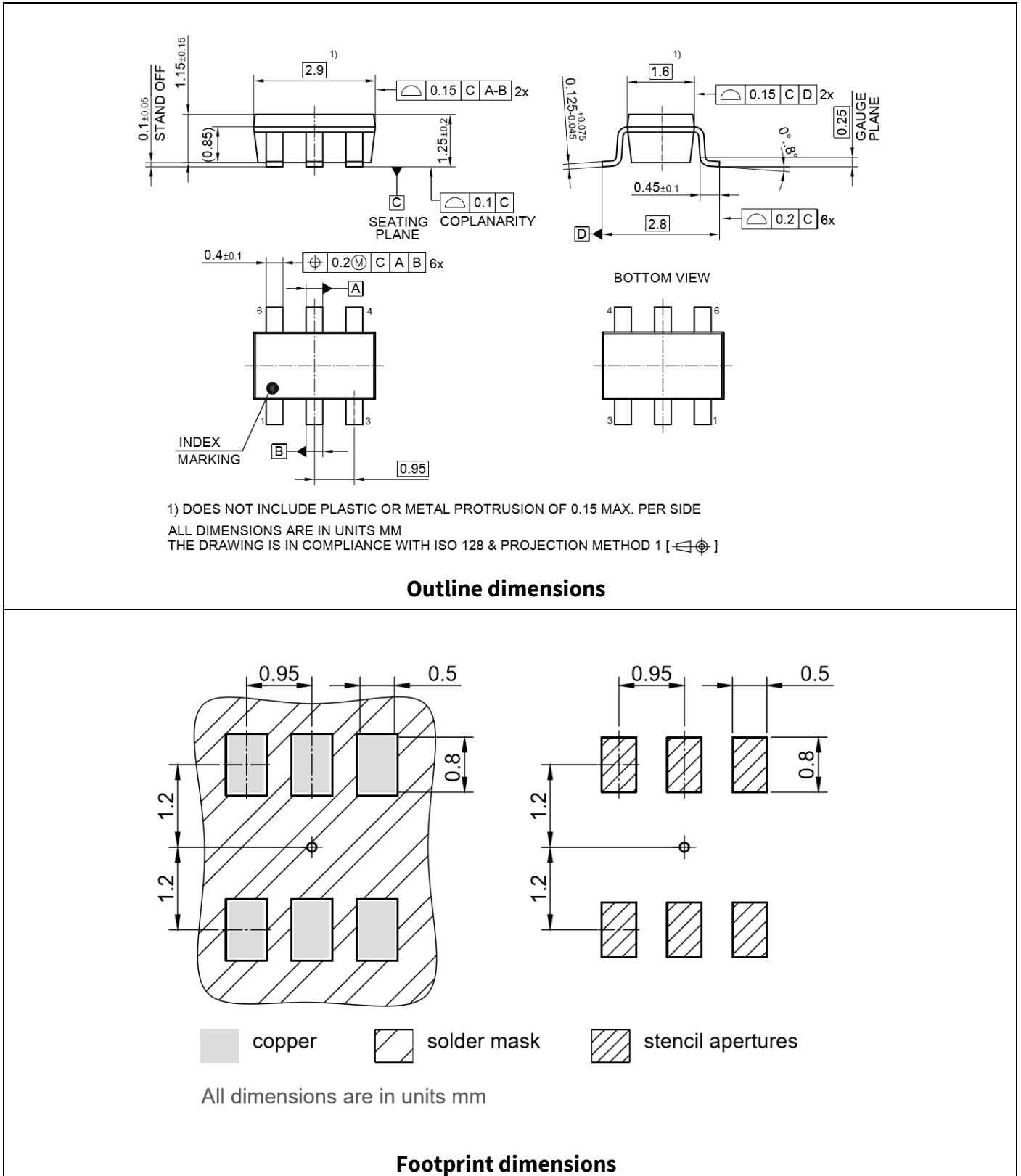

Figure 14 Package outline

7 Tape and reel details

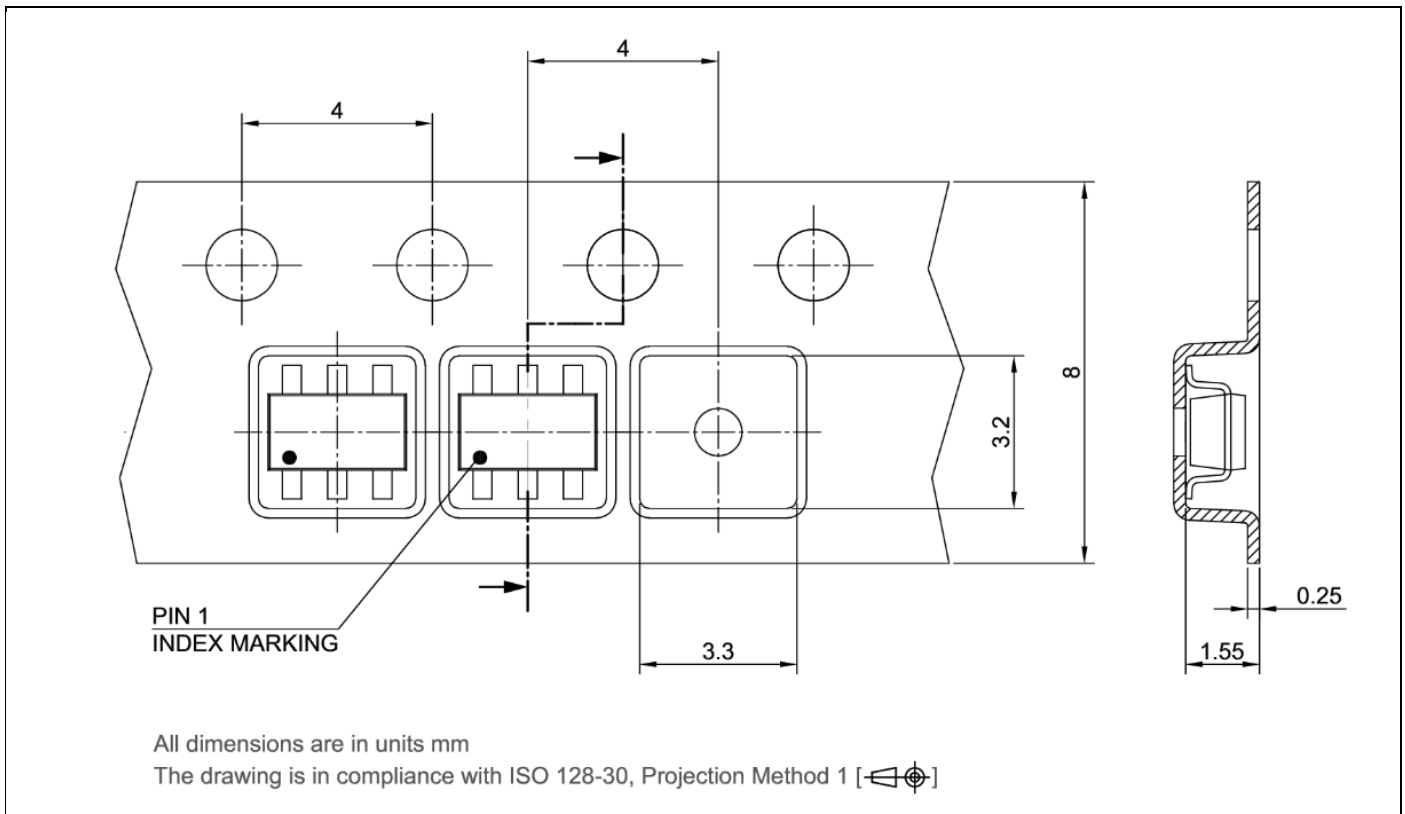

Figure 15 Tape and reel dimensions

Notes: For further details, please visit www.infineon.com/packages

8 Part marking information

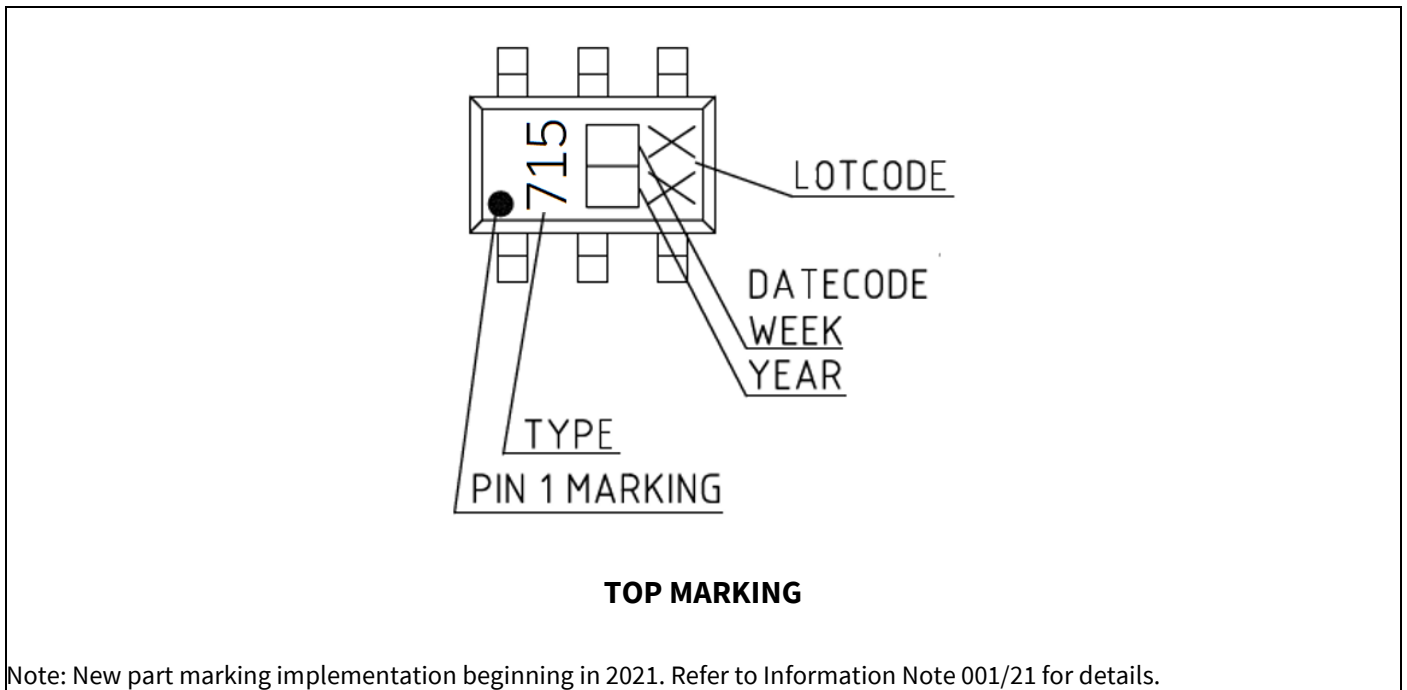

Figure 16 Part marking information

9 Similar products

Channels	Typ. gate drive (Io+/Io-)	Part number	Max supply voltage	UVLO (on/off)	Typ. prop. delay (on/off)	Logic and features	Package options
	A		V	V	ns		
1	1.5/1.5	IR44273L	20	5 / 4.15	50 / 50	Single non-inverting channel Dual OUT pins	SOT23-5L
	0.8/1.75	1ED44176	25	11.9/11.4	50 / 50	Single positive current sense OCP, fault out and ENABLE	PG-DSO-8
	2.6/2.6	1ED44173	25	8/7.3	34 / 34	Single negative current sense OCP, fault out and ENABLE	SOT23-6-3
2	2.3 / 3.3	IRS4426S	25		50 / 50	Dual inverting channels	SOIC-8L
		IRS44262S	20	10.2 / 9.2	50 / 50	Dual inverting channels	SOIC-8L
		IRS4427S	25		50 / 50	Dual non-inverting channels	SOIC-8L
		IRS4428S	25		50 / 50	Single inverting channel Single non-inverting channel	SOIC-8L
	10/10	2ED24427	24	11.5/10	40 / 55	Dual non-inverting channels with ENABLE	Power Pad DSO-8

10 Related documents

1. **AN2019-37** Low – side IGBT driver with over current protection and fault/enable (negative current sense)
2. Datasheet of **1ED44173N01B** and **1ED44176N01B**

Revision history

Document version	Date of release	Description of changes
1.0	Oct. 15, 2019	Final Datasheet
1.1	Apr. 15, 2020	Modified the formula of t_{FLTC} on page 12 (Added negative sign)
1.2	Jul. 22, 2021	Updated the marking, adding a line for lot code to improve traceability. Updated the table of similar products (Deleted Gen.7 parts and added 2ED24427).

Trademarks

All referenced product or service names and trademarks are the property of their respective owners.

Edition 2021-07-22

Published by

Infineon Technologies AG

81726 Munich, Germany

© 2021 Infineon Technologies AG.

All Rights Reserved.

Do you have a question about this document?

Email: erratum@infineon.com

Document reference

IMPORTANT NOTICE

The information given in this document shall in no event be regarded as a guarantee of conditions or characteristics ("Beschaffheitsgarantie").

With respect to any examples, hints or any typical values stated herein and/or any information regarding the application of the product, Infineon Technologies hereby disclaims any and all warranties and liabilities of any kind, including without limitation warranties of non-infringement of intellectual property rights of any third party.

In addition, any information given in this document is subject to customer's compliance with its obligations stated in this document and any applicable legal requirements, norms and standards concerning customer's products and any use of the product of Infineon Technologies in customer's applications.

The data contained in this document is exclusively intended for technically trained staff. It is the responsibility of customer's technical departments to evaluate the suitability of the product for the intended application and the completeness of the product information given in this document with respect to such application.

For further information on the product, technology, delivery terms and conditions and prices please contact your nearest Infineon Technologies office (www.infineon.com).



WARNINGS

Due to technical requirements products may contain dangerous substances. For information on the types in question please contact your nearest Infineon Technologies office.

Except as otherwise explicitly approved by Infineon Technologies in a written document signed by authorized representatives of Infineon Technologies, Infineon Technologies' products may not be used in any applications where a failure of the product or any consequences of the use thereof can reasonably be expected to result in personal injury.

Looking for pricing, stock, or lifecycle information?

Click below to explore more details on WIN SOURCE:

-  [View 1ED44175N01BXTSA1 on WIN SOURCE](#)
-  [Infineon Technologies Information](#)

Optimize Your Supply Chain with WIN SOURCE Solutions

-  Global Sourcing Solution
-  Obsolete Management
-  Cost Control Management
-  Shortage Management
-  Alternative Solution
-  Excess Inventory Management