



# THE DATASHEET OF JFE150DCKT



# JFE150 Ultra-Low-Noise, Low-Gate-Current, Audio, N-Channel JFET



## 1 Features

- Ultra-low noise:
  - Voltage noise:
    - 0.8 nV/ $\sqrt{\text{Hz}}$  at 1 kHz,  $I_{DS} = 5 \text{ mA}$
    - 0.9 nV/ $\sqrt{\text{Hz}}$  at 1 kHz,  $I_{DS} = 2 \text{ mA}$
  - Current noise: 1.8 fA/ $\sqrt{\text{Hz}}$  at 1 kHz
- Low gate current: 10 pA (max)
- Low input capacitance: 24 pF at  $V_{DS} = 5 \text{ V}$
- High gate-to-drain and gate-to-source breakdown voltage:  $-40 \text{ V}$
- High transconductance: 68 mS
- Packages: Small SC70 and SOT-23

## 2 Applications

- Microphone inputs
- Hydrophones and marine equipment
- DJ controllers, mixers, and other DJ equipment
- Professional audio mixer or control surface
- Guitar amplifier and other music instrument amplifier
- Condition monitoring sensor

## 3 Description

The JFE150 is a Burr-Brown™ discrete JFET built using Texas Instruments' modern, high-performance, analog bipolar process. The JFE150 features performance not previously available in older discrete JFET technologies. The JFE150 offers the maximum possible noise-to-power efficiency and flexibility, where the quiescent current can be set by the user

and yields excellent noise performance for currents from 50  $\mu\text{A}$  to 20 mA. When biased at 5 mA, the device yields 0.8 nV/ $\sqrt{\text{Hz}}$  of input-referred noise, giving ultra-low noise performance with extremely high input impedance ( $> 1 \text{ T}\Omega$ ). The JFE150 also features integrated diodes connected to separate clamp nodes to provide protection without the addition of high-leakage, nonlinear, external diodes.

The JFE150 can withstand a high drain-to-source voltage of 40 V, as well as gate-to-source and gate-to-drain voltages down to  $-40 \text{ V}$ . The temperature range is specified from  $-40^\circ\text{C}$  to  $+125^\circ\text{C}$ . The device is offered in 5-pin SOT-23 and SC70 packages.

### Package Information

PART NUMBER	PACKAGE <sup>(1)</sup>	BODY SIZE (NOM)
JFE150	DBV (SOT-23, 5)	2.90 mm × 1.60 mm
	DCK (SC70, 5)	2.00 mm × 1.25 mm

(1) For all available packages, see the package option addendum at the end of the data sheet.

### Device Summary

PARAMETER	VALUE	
$V_{GSS}$	Gate-to-source breakdown voltage	$-40 \text{ V}$
$V_{DSS}$	Drain-to-source breakdown voltage	$\pm 40 \text{ V}$
$C_{ISS}$	Input capacitance	24 pF
$T_J$	Junction temperature	$-40^\circ\text{C}$ to $+125^\circ\text{C}$
$I_{DSS}$	Drain-to-source saturation current	35 mA

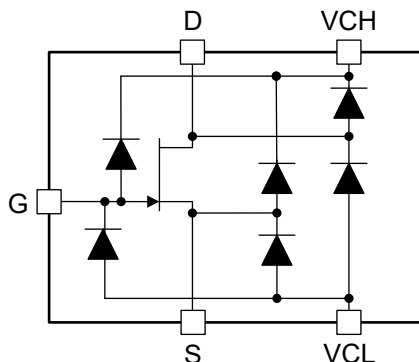

Functional Block Diagram

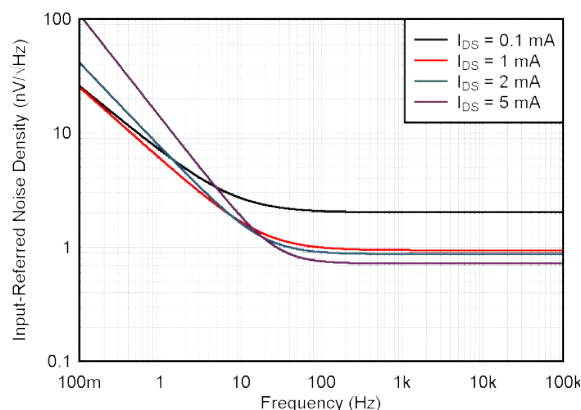

Ultra-Low Input Voltage Noise



## Table of Contents

<b>1 Features</b> .....	1	8.3 Feature Description.....	9
<b>2 Applications</b> .....	1	8.4 Device Functional Modes.....	10
<b>3 Description</b> .....	1	<b>9 Application and Implementation</b> .....	11
<b>4 Revision History</b> .....	2	9.1 Application Information.....	11
<b>5 Pin Configuration and Functions</b> .....	3	9.2 Typical Application.....	14
<b>6 Specifications</b> .....	4	9.3 Power Supply Recommendations.....	16
6.1 Absolute Maximum Ratings.....	4	9.4 Layout.....	16
6.2 ESD Ratings.....	4	<b>10 Device and Documentation Support</b> .....	17
6.3 Recommended Operating Conditions.....	4	10.1 Device Support.....	17
6.4 Thermal Information.....	4	10.2 Documentation Support.....	18
6.5 Electrical Characteristics.....	5	10.3 Receiving Notification of Documentation Updates.....	18
6.6 Typical Characteristics.....	6	10.4 Support Resources.....	18
<b>7 Parameter Measurement Information</b> .....	8	10.5 Trademarks.....	18
7.1 AC Measurement Configurations.....	8	10.6 Electrostatic Discharge Caution.....	18
<b>8 Detailed Description</b> .....	9	10.7 Glossary.....	18
8.1 Overview.....	9	<b>11 Mechanical, Packaging, and Orderable Information</b> .....	18
8.2 Functional Block Diagram.....	9		

## 4 Revision History

NOTE: Page numbers for previous revisions may differ from page numbers in the current version.

<b>Changes from Revision A (November 2021) to Revision B (April 2023)</b>	<b>Page</b>
• Changed DBV package (SOT-23, 5) from preview to production data (active) and added associated content.	1
• Changed parameter descriptions from "gate-to-source voltage" to "gate-to-source breakdown voltage" and from "drain-to-source voltage" to "drain-to-source breakdown voltage" in <i>Device Summary</i> table to match <i>Electrical Characteristics</i> .....	1
• Changed "drain-to-source saturation current" value from 36 mA to 35 mA in <i>Device Summary</i> table to match <i>Electrical Characteristics</i> .....	1
• Changed VCH and VCL pin type and description in <i>Pin Functions</i> to reflect optional nature of diode clamps....	3
• Changed Figure 6-2, <i>Drain-to-Source Current vs Drain-to-Source Voltage</i> , to show correct $V_{GS}$ values.....	6
• Changed Figure 8-1, $V_{DS}$ vs $I_{DS}$ , to show correct $V_{GS}$ values and improve image resolution.....	10
• Added JFE150EVM user's guide and JFE150 Ultra-Low-Noise Pre-Amp application note to <i>Related Documentation</i> .....	18

<b>Changes from Revision * (June 2021) to Revision A (November 2021)</b>	<b>Page</b>
• Changed $V_{GS}$ minimum from $-1.1$ V to $-1.3$ V (100 $\mu$ A), $-0.9$ V to $-1.1$ V (2 mA) .....	5
• Changed Figure 6-3, <i>Drain-to-Source Current vs Drain-to-Source Voltage</i> , to show correct $V_{GS}$ values.....	6

## 5 Pin Configuration and Functions

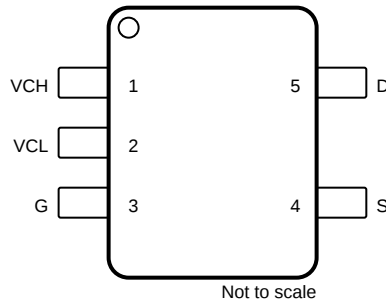

**Figure 5-1. DBV, 5-Pin SOT-23 and DCK, 5-Pin SC70 Packages (Top View)**

**Table 5-1. Pin Functions**

PIN		TYPE	DESCRIPTION
NAME	NO.		
D	5	Output	Drain
G	3	Input	Gate
S	4	Output	Source
VCH	1	—	Positive diode clamp voltage. Float this pin if clamp diodes are not used.
VCL	2	—	Negative diode clamp voltage. Float this pin if clamp diodes are not used.

## 6 Specifications

### 6.1 Absolute Maximum Ratings

over operating free-air temperature range (unless otherwise noted)<sup>(1)</sup>

		MIN	MAX	UNIT
V <sub>DS</sub>	Drain-to-source voltage	-40	40	V
V <sub>GS</sub> , V <sub>GD</sub>	Gate-to-source, gate-to-drain voltage	-40	0.9	V
V <sub>VCH</sub>	Voltage between VCH to D, G, or S		40	V
V <sub>VCL</sub>	Voltage between VCL to D, G, or S	-40		
I <sub>VCL</sub> , I <sub>VCH</sub>	Clamp diode current	DC	20	mA
		50-ms pulse <sup>(2)</sup>	200	
I <sub>DS</sub>	Drain-to-source current	-50	50	mA
I <sub>GS</sub> , I <sub>GD</sub>	Gate-to-source, gate-to-drain current	-20	20	mA
T <sub>A</sub>	Ambient temperature	-55	150	°C
T <sub>J</sub>	Junction temperature	-55	150	°C
T <sub>stg</sub>	Storage temperature	-55	175	°C

- (1) Operation outside the Absolute Maximum Ratings may cause permanent device damage. Absolute Maximum Ratings do not imply functional operation of the device at these or any other conditions beyond those listed under Recommended Operating Conditions. If used outside the Recommended Operating Conditions but within the Absolute Maximum Ratings, the device may not be fully functional, and this may affect device reliability, functionality, performance, and shorten the device lifetime.
- (2) Maximum diode current pulse specified for 50 ms at 1% duty cycle.

### 6.2 ESD Ratings

			VALUE	UNIT
V <sub>(ESD)</sub>	Electrostatic discharge	Human body model (HBM), per ANSI/ESDA/JEDEC JS-001 <sup>(1)</sup>	±2500	V
		Charged device model (CDM), per ANSI/ESDA/JEDEC JS-002 <sup>(2)</sup>	±500	

- (1) JEDEC document JEP155 states that 500-V HBM allows safe manufacturing with a standard ESD control process.
- (2) JEDEC document JEP157 states that 250-V CDM allows safe manufacturing with a standard ESD control process.

### 6.3 Recommended Operating Conditions

over operating free-air temperature range (unless otherwise noted)

		MIN	NOM	MAX	UNIT
I <sub>DS</sub>	Drain-to-source current	0.02		I <sub>DSS</sub>	mA
V <sub>GS</sub>	Gate-to-source voltage	0		-1.2	V
T <sub>A</sub>	Specified temperature	-40		125	°C

### 6.4 Thermal Information

THERMAL METRIC <sup>(1)</sup>		JFE150		UNIT
		DCK (SC70)	DBV (SOT-23)	
		5 PINS	5 PINS	
R <sub>θJA</sub>	Junction-to-ambient thermal resistance	197.1	183.8	°C/W
R <sub>θJC(top)</sub>	Junction-to-case (top) thermal resistance	93.7	83.2	°C/W
R <sub>θJB</sub>	Junction-to-board thermal resistance	44.8	51.7	°C/W
ψ <sub>JT</sub>	Junction-to-top characterization parameter	16.7	24.9	°C/W
ψ <sub>JB</sub>	Junction-to-board characterization parameter	44.6	51.4	°C/W
R <sub>θJC(bot)</sub>	Junction-to-case (bottom) thermal resistance	N/A	N/A	°C/W

- (1) For more information about traditional and new thermal metrics, see the [Semiconductor and IC Package Thermal Metrics](#) application report.

## 6.5 Electrical Characteristics

at  $T_A = 25^\circ\text{C}$ ,  $I_{DS} = 2\text{ mA}$ , and  $V_{DS} = 10\text{ V}$  (unless otherwise noted)

PARAMETER		TEST CONDITIONS		MIN	TYP	MAX	UNIT	
<b>NOISE</b>								
$e_n$	Input-referred voltage noise density	$I_{DS} = 100\ \mu\text{A}$ , $V_{DS} = 5\text{ V}$	$f = 10\text{ Hz}$		3		nV/ $\sqrt{\text{Hz}}$	
			$f = 1\text{ kHz}$		2			
		$I_{DS} = 2\text{ mA}$ , $V_{DS} = 5\text{ V}$	$f = 10\text{ Hz}$		1.6			
			$f = 1\text{ kHz}$		0.9			
		$I_{DS} = 5\text{ mA}$ , $V_{DS} = 5\text{ V}$	$f = 10\text{ Hz}$		1.8			
			$f = 1\text{ kHz}$		0.8			
Input-referred voltage noise	$f = 0.1\text{ Hz to }10\text{ Hz}$ , $V_{DS} = 5\text{ V}$	$I_{DS} = 100\ \mu\text{A}$		0.19		$\mu\text{V}_{PP}$		
		$I_{DS} = 2\text{ mA}$		0.09				
		$I_{DS} = 5\text{ mA}$		0.13				
$e_i$	Input current noise	$f = 1\text{ kHz}$ , $V_{DS} = 5\text{ V}$			1.8		fA/ $\sqrt{\text{Hz}}$	
<b>INPUT CURRENT</b>								
$I_G$	Input gate current	$V_{DS} = 2\text{ V}$ , $V_{GS} = -0.7\text{ V}$ , $V_{VCH} = 5\text{ V}$ , $V_{VCL} = -5\text{ V}$			0.2	$\pm 10$	pA	
					0.2			
		$V_{DS} = 0\text{ V}$ , $V_{GS} = -30\text{ V}$	$T_A = -40^\circ\text{C to }+85^\circ\text{C}$					$\pm 2000$
			$T_A = -40^\circ\text{C to }+125^\circ\text{C}$					$\pm 10000$
<b>INPUT VOLTAGE</b>								
$V_{GSS}$	Gate-to-source breakdown voltage	$V_{DS} = 0\text{ V}$ , $ I_G  < 100\ \mu\text{A}$				-40	V	
$V_{GSC}$	Gate-to-source cutoff voltage	$V_{DS} = 10\text{ V}$ , $I_{DS} = 0.1\ \mu\text{A}$		-1.5	-1.2	-0.9	V	
$V_{GS}$	Gate-to-source voltage	$I_{DS} = 100\ \mu\text{A}$		-1.3		-0.7	V	
		$I_{DS} = 2\text{ mA}$		-1.1		-0.5		
<b>INPUT IMPEDANCE</b>								
$R_{IN}$	Gate input resistance	$V_{GS} = -5\text{ V to }0\text{ V}$ , $V_{DS} = 0\text{ V}$			1		T $\Omega$	
$C_{ISS}$	Input capacitance	$V_{DS} = 0\text{ V}$			30		pF	
		$V_{DS} = 5\text{ V}$			24			
$C_{RSS}$	Reverse transfer capacitance	$V_{DS} = 0\text{ V}$			7			
<b>OUTPUT</b>								
$I_{DSS}$	Drain-to-source saturation current	$V_{DS} = 10\text{ V}$ , $V_{GS} = 0\text{ V}$		24	35	46	mA	
			$T_A = -40^\circ\text{C to }+125^\circ\text{C}$	22		57		
$g_m$	Transconductance	$I_{DS} = 100\ \mu\text{A}$			3		mS	
		$I_{DS} = 2\text{ mA}$			18			
$G_{FS}$	Full conduction transconductance	$V_{DS} = 10\text{ V}$ , $V_{GS} = 0\text{ V}$		55	68	80	mS	
$V_{DSS}$	Drain-to-source breakdown voltage	$ I_{DS}  < 100\ \mu\text{A}$ , $V_{GS} = -2\text{ V}$		40			V	
$C_{OSS}$	Output capacitance	$V_{DS} = 5\text{ V}$			8		pF	

## 6.6 Typical Characteristics

at  $T_A = 25^\circ\text{C}$ ,  $I_{DS} = 2\text{ mA}$ , common-source configuration, and  $V_{DS} = 5\text{ V}$  (unless otherwise noted)

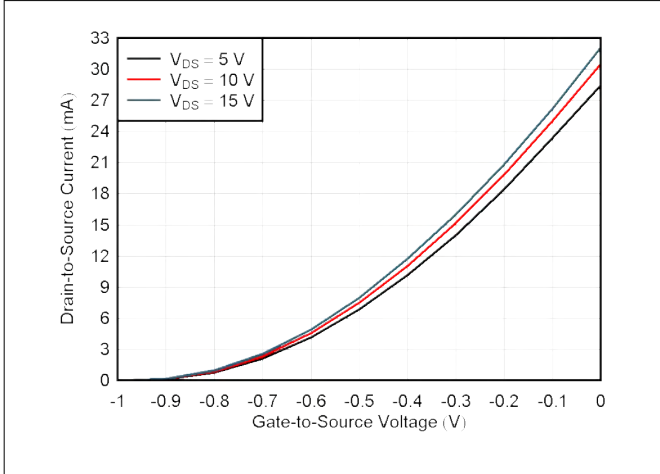

Figure 6-1. Drain-to-Source Current vs Gate-to-Source Voltage

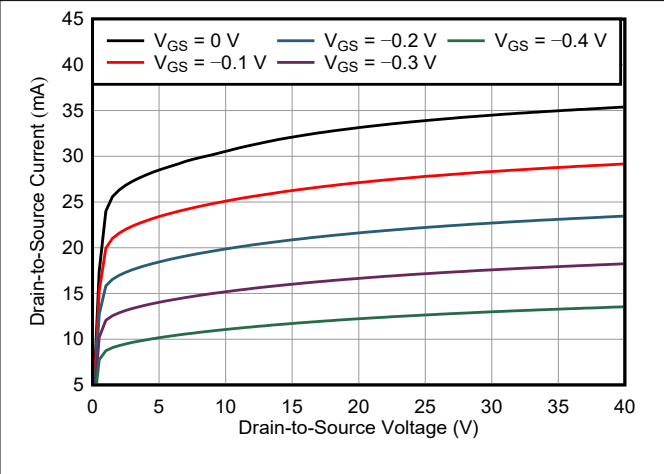

Figure 6-2. Drain-to-Source Current vs Drain-to-Source Voltage

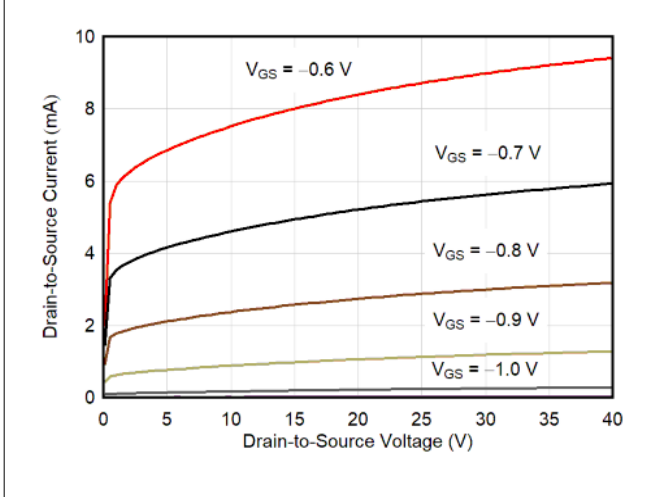

Figure 6-3. Drain-to-Source Current vs Drain-to-Source Voltage

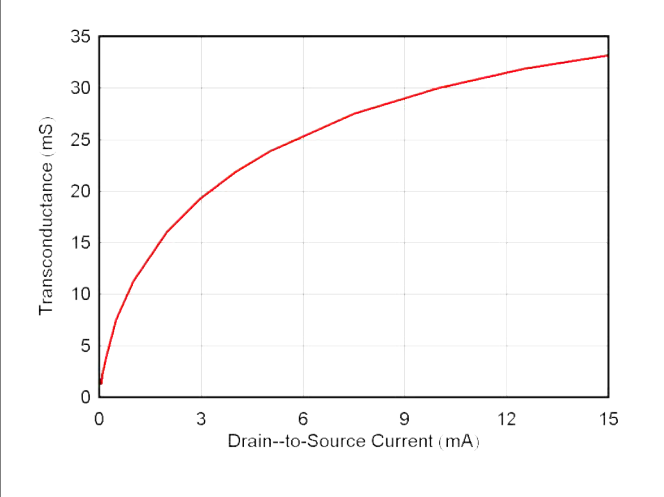

Figure 6-4. Common Source Transconductance vs Drain-to-Source Current

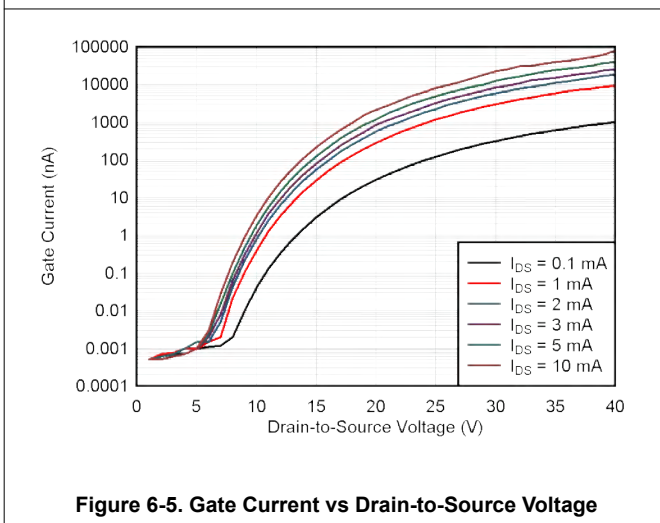

Figure 6-5. Gate Current vs Drain-to-Source Voltage

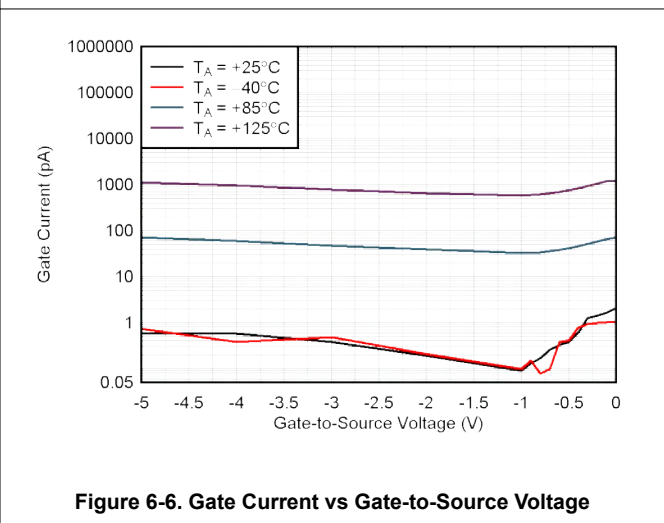

Figure 6-6. Gate Current vs Gate-to-Source Voltage

### 6.6 Typical Characteristics (continued)

at  $T_A = 25^\circ\text{C}$ ,  $I_{DS} = 2\text{ mA}$ , common-source configuration, and  $V_{DS} = 5\text{ V}$  (unless otherwise noted)

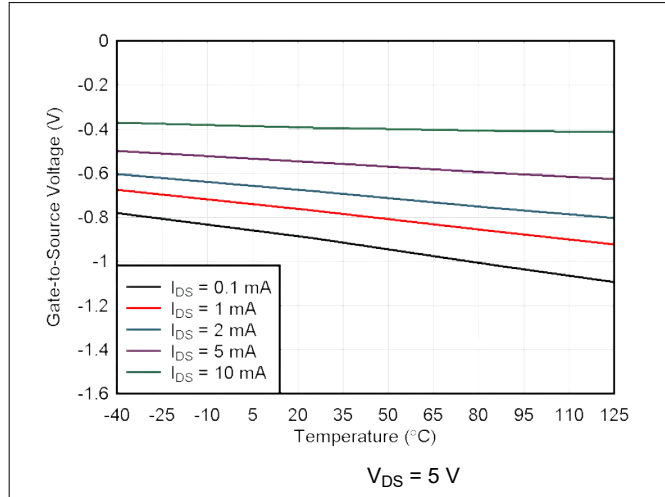

Figure 6-7. Gate-to-Source Voltage vs Temperature

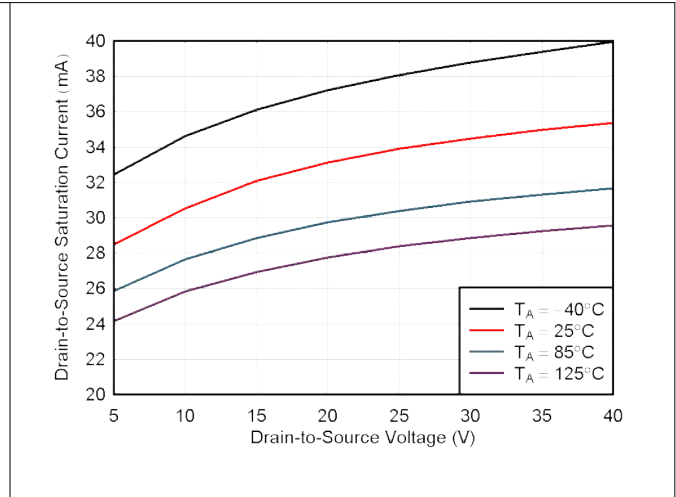

Figure 6-8.  $I_{DSS}$  vs Drain-to-Source Voltage

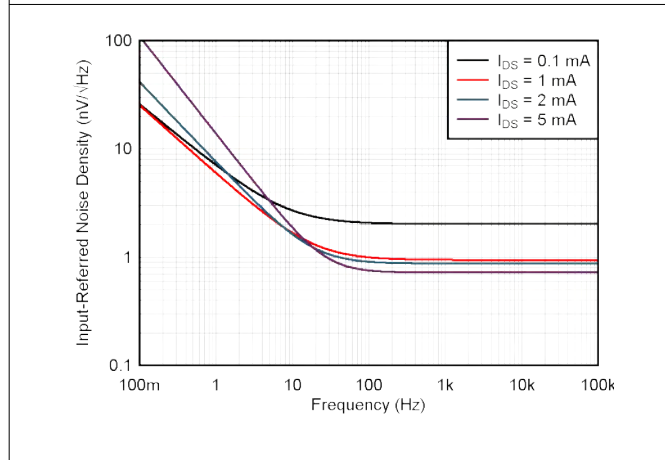

Figure 6-9. Input-Referred Noise Density vs Frequency

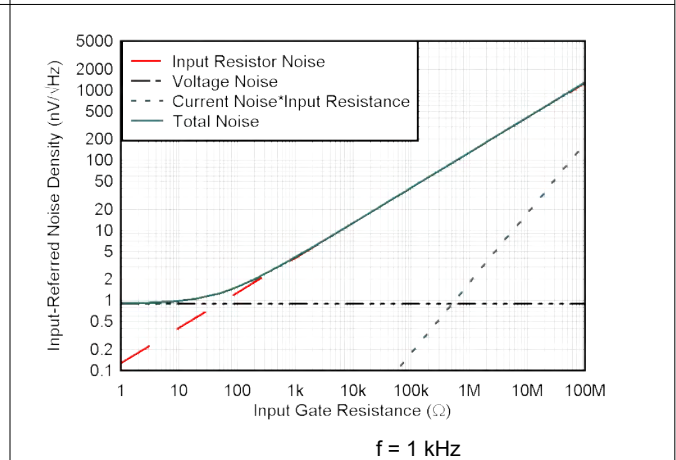

Figure 6-10. Noise Density Contributors vs Input Gate Resistance

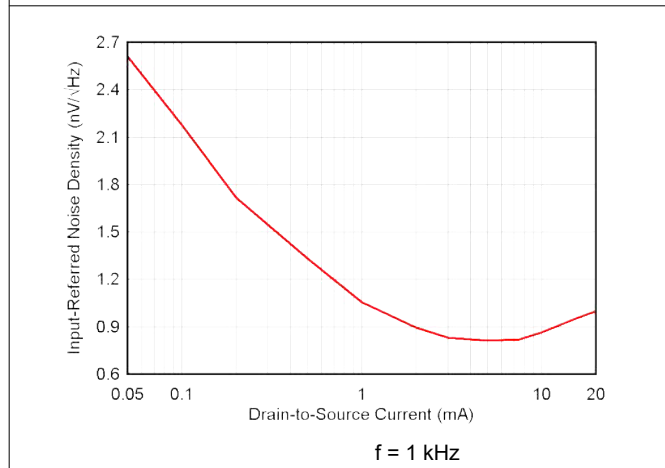

Figure 6-11. Input-Referred Noise Spectral Density vs Drain-to-Source Current

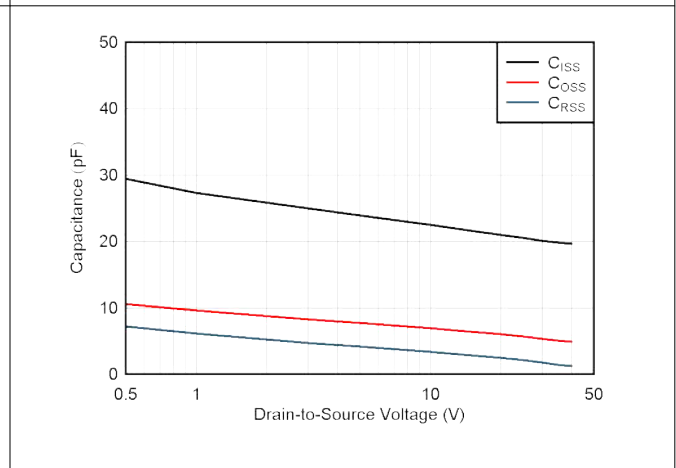
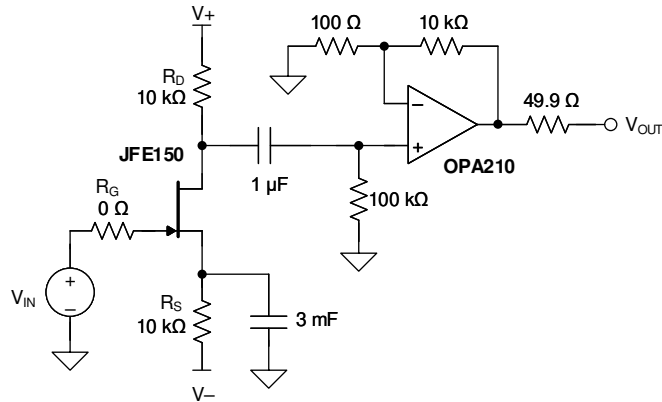

Figure 6-12. Input, Output, and Reverse Transfer Capacitance vs Drain-to-Source Voltage

## 7 Parameter Measurement Information

### 7.1 AC Measurement Configurations

The circuit configuration used for noise measurements is seen in [Figure 7-1](#). The nominal  $I_{DS}$  current is configured in the schematic by calibrating  $V_-$ . After  $I_{DS}$  is fixed, the  $V_{DS}$  voltage is set by calibrating  $V_+$ . For input-referred noise data, the gain of the circuit is calibrated from  $V_{IN}$  to  $V_{OUT}$  and used for the input-referred gain calculation.



**Figure 7-1. AC Measurement Reference Schematic**

## 8 Detailed Description

### 8.1 Overview

The JFE150 is an ultra-low noise JFET designed to create low-noise gain stages for very high output impedance sensors or microphones. Advanced processing technology gives the JFE150 extremely low-noise performance, a high  $g_m/C_{ISS}$  ratio, and ultra-low gate-current performance. Input protection diodes are integrated to clamp high-voltage spurious input signals without the need for additional input diodes that can add leakage current or distortion-creating non-linear capacitance. The JFE150 provides a next-generation device to implement low-noise amplifiers for piezoelectric sensors, transducers, large-area condenser microphones, and hydrophones in small-package options.

### 8.2 Functional Block Diagram

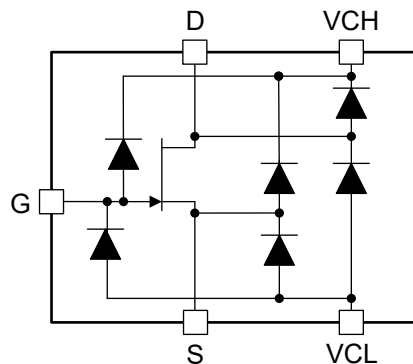

### 8.3 Feature Description

#### 8.3.1 Ultra-Low Noise

Junction-gate field-effect transistors (JFETs) are commonly used as an input stage in high-input-impedance, low-noise designs in audio, SONAR, vibration analysis, and other technologies. The JFE150 is a new generation JFET device that offers very low noise performance at the lowest possible current consumption in high-input-impedance amplifier designs. The JFE150 is manufactured on a high-performance analog process technology, giving tighter process parameter control than a standard JFET.

Designs that feature operational amplifiers (op amps) as the primary gain stage are common, but these designs are not able to achieve the lowest possible noise as a result of the inherent challenges and tradeoffs required from a full operational amplifier design. Noise in JFET designs can be evaluated in two separate regions: low-frequency flicker noise and wideband thermal noise. Flicker, or  $1/f$  noise, is extremely important for systems that require signal gain at frequencies less than 100 Hz. The JFE150 achieves extremely low  $1/f$  noise in this range. Thermal noise is noise in the region greater than 1 kHz and depends on the gain, or  $g_m$ , of the circuit. The  $g_m$  is a function of the drain-to-source bias current; therefore, thermal noise is also a function of drain-to-source bias current. [Figure 6-9](#) shows both  $1/f$  and thermal noise with multiple bias conditions measured using the circuit shown in [Figure 7-1](#).

Noise is typically modeled as a voltage source (voltage noise) and current source (current noise) on the input. The  $1/f$  and thermal noise can be represented as voltage noise. Current noise is dominated by current flow into the gate, and is called *shot noise*. The JFE150 features extremely low gate current, and therefore, extremely low current noise. [Figure 6-10](#) shows how source impedance on the input is the dominant noise source. In nearly all cases, noise created as a result of current noise is negligible.

#### 8.3.2 Low Gate Current

The JFE150 features a maximum gate current of 10 pA at room temperature, making the device an excellent choice for maximizing the gain and dynamic range from extremely high impedance sensors. Additionally, any noise contributions as a result of gate current are minimized because of the negligible shot noise at low current levels. As with all JFET devices, when the drain-to-source voltage increases, the gate current also increases. Keep the drain-to-source voltage to less than 5 V for the lowest gate input current operation.

### 8.3.3 Input Protection

The JFE150 features input protection diodes that are used for surge clamping and ESD events. The diodes are rated to withstand high current surges for short times, steering current from the gate (G) pin to the VCH and VCL pins. The diodes also feature very low leakage, removing the need for external protection devices that can have high leakage currents or nonlinear capacitance that degrade the distortion performance.

### 8.4 Device Functional Modes

The JFE150 functionality is identical to standard N-channel depletion JFET devices. The gate-to-source ( $V_{GS}$ ) voltage, drain-to-source voltage ( $V_{DS}$ ) and drain-to-source current ( $I_{DS}$ ) determine the region of operation.

- For  $V_{GS} < V_{GSC}$ : JFE150 conduction channel is closed;  $I_{DS}$  is only determined by junction leakage current.
- For  $V_{GS} > V_{GSC}$ : Two modes of operation can exist depending on  $V_{DS}$ . When  $V_{DS}$  is less than the linear (saturation) region threshold (see [Figure 8-1](#)), the device operates in the linear region, meaning that the device behaves as a resistor connected from drain-to-source with minimal variation from any changes in  $V_{GS}$ . When  $V_{DS}$  is greater than the linear (saturation) region threshold,  $I_{DS}$  has a strong dependence on  $V_{GS}$ , where the relationship is described by the parameter  $g_m$ .

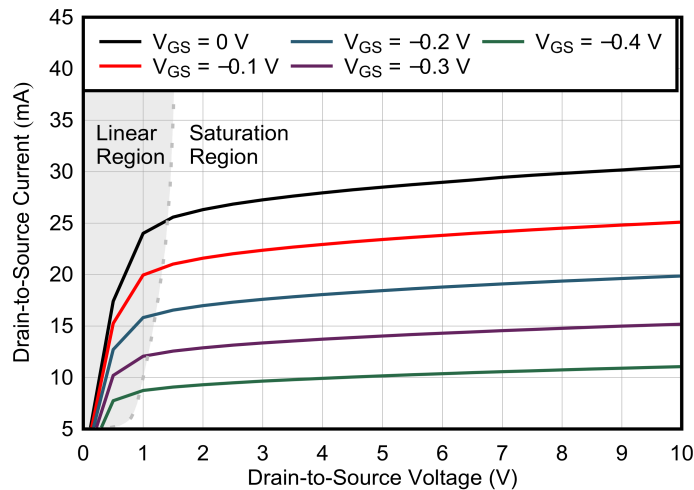

**Figure 8-1.  $V_{DS}$  vs  $I_{DS}$**

## 9 Application and Implementation

### Note

Information in the following applications sections is not part of the TI component specification, and TI does not warrant its accuracy or completeness. TI's customers are responsible for determining suitability of components for their purposes, as well as validating and testing their design implementation to confirm system functionality.

### 9.1 Application Information

#### 9.1.1 Input Protection Diodes

The JFE150 features diodes that are used to help clamp voltage surges that can occur on the input sensor to the gate. The diodes are connected between the gate and two separate pins, VCL and VCH. The clamping mechanism works by *steering* current from the gate into the VCL or VCH nodes when the voltage at the gate is less than VCL or greater than VCH. Figure 9-1 shows an example of a microphone input circuit where a dc blocking capacitor operates with a large dc voltage. When the microphone input is dropped or shorted, the dc blocking capacitor discharges into the VCL or VCH nodes, thus helping eliminate large signal transient voltages on the gate. There are also clamping diodes from the drain and source to VCL and VCH, respectively. The clamping diodes can withstand high surge currents up to 200 mA for 50 ms; however, limit dc current to less than 20 mA.

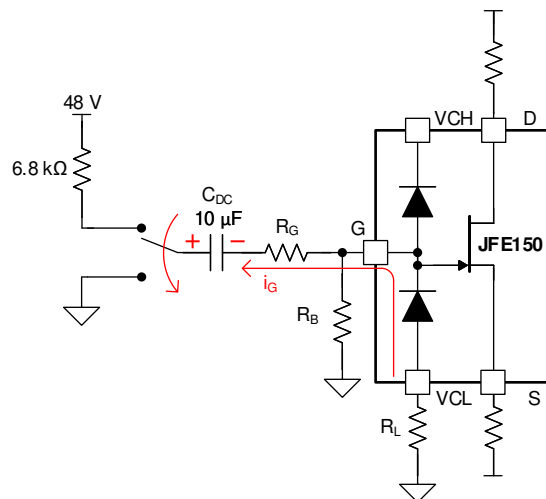

Figure 9-1. JFE150 Clamping Diode Example

Figure 9-1 shows an example of configuring the diode clamp to protect the JFET against overvoltage in a phantom-powered microphone circuit. Phantom power typically delivers 48 V through a 6.8-k $\Omega$  pullup resistor to a microphone or dynamic load. If the microphone is disconnected, dc blocking capacitor  $C_{DC}$  can be biased up to 48 V. If the input to the capacitor is then shorted to ground (shown by the switch in Figure 9-1), the gate voltage can exceed the absolute maximum rating for  $V_{GS}$ . In this case, the blocking diode is used, along with current limiting resistors  $R_G$  and  $R_L$ , to clamp the gate voltage to a safe level. Be aware that the thermal noise of  $R_G$  couples directly into the gate input; therefore, make sure to minimize the resistance of  $R_G$ .

The clamping diodes are not required for operation. The  $V_{GS}$  voltage can withstand  $-40$  V, so clamping is not required if the  $V_{GS}$  voltage is kept greater than this limit. If the diodes are not needed, leave the VCL and VCH nodes floating.

Most previous-generation JFET devices featured only three pins (gate, source, and drain). For these devices, the gate pin is in the same physical location as the VCL pin on the JFE150. To test the JFE150 in a three-pin socket, short pin 2 of the JFE150 (VCL) to pin 3 (G). When the devices are connected with pin 2 shorted to pin 3, the diode from VCL is shorted out and cannot provide any clamping protection. The input capacitance ( $C_{ISS}$ ) also increases by 1 pF; see Figure 6-12.

### 9.1.2 Capacitive Transducer Input Stage

Piezoelectric transducers are used for many different applications that require low-noise, high-gain performance. These transducers exhibit high output impedance ( $> 10 \text{ M}\Omega$ ), and therefore require very high impedance loading for subsequent input stages. The JFE150 has ultra-low input gate current (maximum  $I_G = \pm 10 \text{ pA}$ ) and low input capacitance ( $C_{ISS} = 24 \text{ pF}$ ), which makes the device an excellent choice for transducers with an effective capacitance of greater than  $240 \text{ pF}$ . For smaller, lower-capacitance transducers, the  $C_{ISS}$  can impact the gain of the front end by attenuating the input signal, thereby reducing the noise performance.

### 9.1.3 Common-Source Amplifier

The common-source amplifier is a commonly used open-loop gain stage for JFET amplifiers. [Figure 9-2](#) shows the basic circuit.

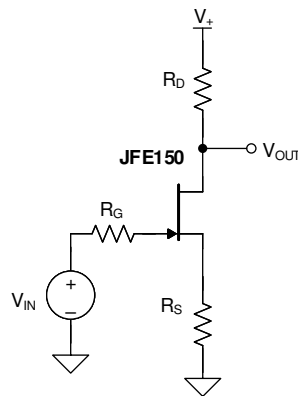
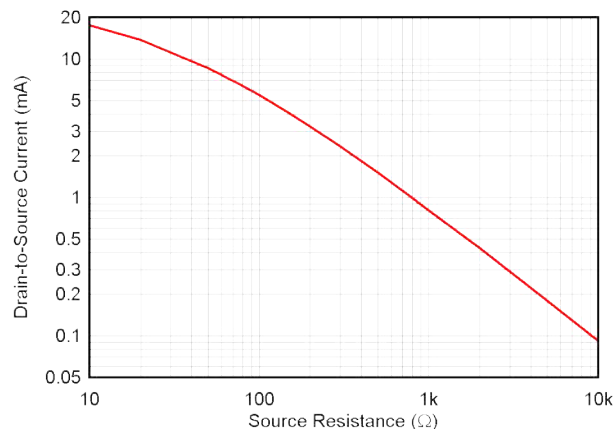

**Figure 9-2. Common-Source Amplifier**

[Equation 1](#) shows the equation for gain of the circuit in [Figure 9-2](#).

$$\frac{V_{OUT}}{V_{IN}} = - \frac{gm * R_D}{1 + gm * R_S} \quad (1)$$

Generally, higher gain results in improved noise performance. Gain increases as the bias current is increased as a result of increasing  $gm$  (see [Figure 6-4](#)). As a result, the input-referred noise decreases as bias current is increased (see [Figure 6-9](#)). Any JFET design must make a tradeoff between current consumption and noise performance. The JFE150, however, delivers significantly lower noise performance than most operational amplifiers at the same current consumption. The bias current ( $I_{DS}$ ) is set by the value of the source resistor,  $R_S$ , and the threshold voltage,  $V_T$ , of the JFE150. [Figure 9-3](#) is a graph showing nominal  $I_{DS}$  vs  $R_S$ .



**Figure 9-3. Drain-to-Source Current vs  $R_S$ ,  $V_{DS} = 5 \text{ V}$**

The bias current varies according to the resistor and threshold voltage tolerances. Additionally, thermal noise associated with  $R_S$  couples directly into the gain of the circuit, degrading the overall noise performance. To improve the circuit in Figure 9-4, use a current-source biasing scheme. Current-source biasing removes the JFET threshold variation from the biasing scheme, and allows for lower-value filtering capacitance ( $C_S$ ) for equivalent filtering due to the high output impedance of current sources.

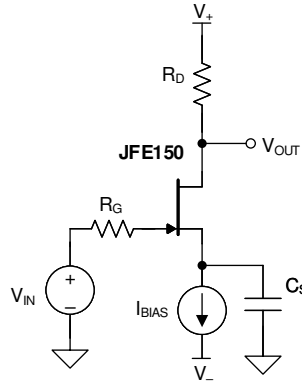
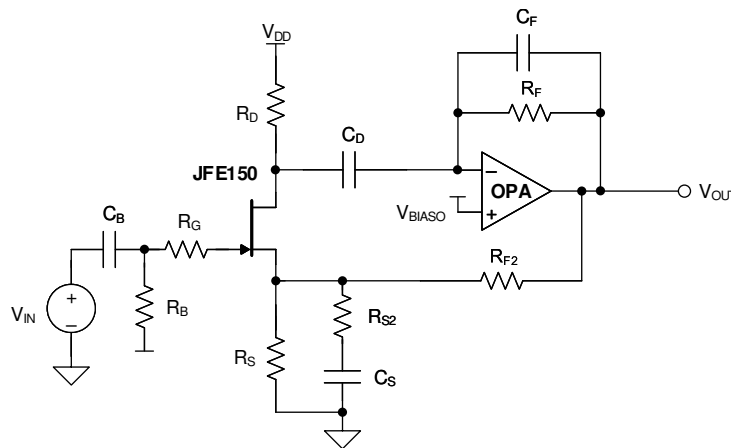

**Figure 9-4. Common-Source Amplifier With Current-Source Biasing**

### 9.1.4 Composite Amplifiers

The JFE150 can be configured to provide a low-noise, high-input impedance front-end stage for a typical op amp. Open-loop transistor gain stages shown previously suffer from wide gain variations that are dependent on the forward transconductance of the JFE150. When precision gain is required, the composite amplifier (JFET front-end + operational amplifier) achieves excellent results by allowing for a fixed gain determined by external resistors, and improving the noise and bandwidth of the operational amplifier. The JFE150 gain stage provides a boost to the open-loop performance of the system, extending the bandwidth beyond what the operational amplifier alone can provide, and gives a high-input impedance, ultra-low noise input stage to interface with high source impedance microphones.

Figure 9-5 shows a generic schematic representation of a current-feedback composite amplifier. The component requirements and tradeoffs are listed in Table 9-1.



**Figure 9-5. Low Noise, High Input Impedance Composite Amplifier**

**Table 9-1. Composite Amplifier Component List and Function**

COMPONENT	DESCRIPTION	RELATED EQUATION
$C_B$	DC blocking capacitor for input source. Use a dc blocking capacitor if the dc voltage of the input source is not the same as the gate bias voltage.	$f_{-3dBDC} = \frac{1}{2 * \pi * R_{B1}    R_{B2} * C_{B1}}$ (2)
$R_B$	Bias resistor. Use biasing resistors to set the dc voltage at the gate. High-value resistors can be used without an impact to noise if the source impedance and bypass capacitor have sufficiently low impedance.	See Equation 2
$R_G$	Gate resistor. Can be used to help limit current flow into gate in overvoltage cases.	
$R_D$	Drain resistor. Sets gain of JFET stage in common source biasing, along with $g_m$ and $R_S$ .	
$R_S$	Source resistor. Used to set bias of JFET; see Figure 9-3. Resistor thermal noise directly impacts noise performance.	
$C_D$	DC blocking capacitor. Blocks nominal drain voltage so the amplifier operates at a midsupply bias point.	
$C_F$	Feedback capacitor. Along with $R_F$ , this capacitor sets the –3-dB high-pass cutoff frequency when the amplifier gain-bandwidth product (GBW) is sufficiently high enough to support the –3-dB frequency. If the GBW is not high enough, then the GBW sets the –3-dB frequency.	$f_{-3dBHP} = \frac{1}{2 * \pi * R_F * C_F}$ (3)
$R_F$	Feedback resistor. Along with $C_F$ , this resistor sets the –3-dB high-pass cutoff frequency when the amplifier gain-bandwidth product (GBW) is sufficiently high enough to support the –3-dB frequency. If the GBW is not high enough, then the GBW sets the –3-dB frequency.	See Equation 3
$R_{F2}$	Current feedback gain-setting resistor 1. Along with $R_{S2}$ , sets gain closed-loop.	$\frac{V_{OUT}}{V_{IN}} = \frac{R_{F2}}{R_{S2}}$ (4)
$R_{S2}$	Current feedback gain-setting resistor 2. Along with $R_{S2}$ , sets gain closed-loop. Resistor thermal noise directly impacts noise performance.	See Equation 4
$C_S$	Current feedback ac-coupling capacitor. This capacitor, along with $R_2$ , sets the low-pass –3-dB frequency.	$f_{-3dBLP} = \frac{1}{2 * \pi * R_{S2} * C_S}$ (5)

## 9.2 Typical Application

The JFE150 can be configured to provide a low-noise, high-input-impedance front-end stage for a typical op amp. Single-transistor gain stages shown previously suffer from wide gain variations dependent on the forward transconductance of the JFE150. When precision gain is required, the composite amplifier (JFET front-end + operational amplifier) achieves excellent results.

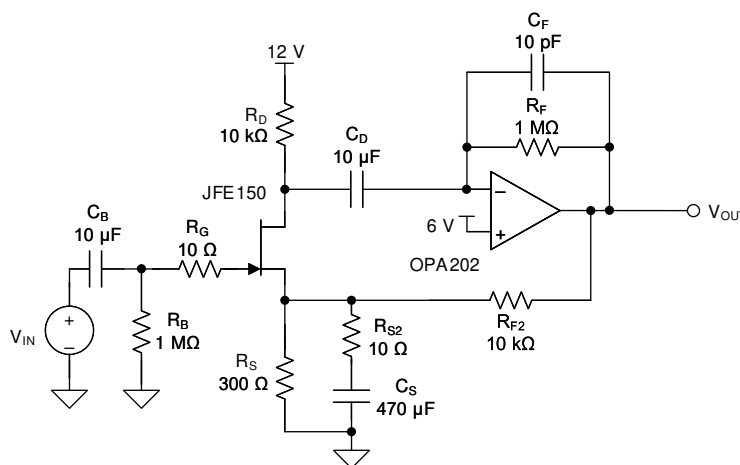
**Figure 9-6. Low-Noise, High-Input-Impedance Composite Amplifier**

### 9.2.1 Design Requirements

PARAMETER	DESIGN GOAL
Gain	60 dB
Frequency response	60 Hz to 20 kHz
Noise	< 1.5 nV/ $\sqrt{\text{Hz}}$
Input current	< 100 pA
Output swing	$\pm 5$ V

### 9.2.2 Detailed Design Procedure

This design provides 60 dB of gain with extremely high input impedance at a very low frequency response. The order of design priorities are as follows:

- The JFE150 bias current is set by selecting the desired bias current and noise tradeoff (see [Figure 6-11](#)). The input-referred noise is dominated by the JFE150 bias current and gain. To set the bias current point, adjust the source resistance according to [Figure 9-3](#).
- After the bias current is selected, set the JFET stage gain as high as possible without pushing the device into the linear region of operation. This is achieved by using the largest drain resistor ( $R_D$ ) possible while maintaining a minimum of 2 V across the drain to source nodes. Be aware that the amplifier forces the drain node to match the noninverting amplifier input in normal closed-loop operation. Both ac and dc voltages must be considered, but generally, only the dc operating point on the drain is considered because the ac voltage swing is minimal.
- Set the closed gain according to  $R_{F2}$  and  $R_{S2}$ , as seen in [Equation 4](#). Thermal noise from  $R_{S2}$  directly couples into the circuit; therefore, small values for this resistor are required.
- $C_S$  is required to block dc voltages from altering the bias point set by source resistor  $R_S$ .  $C_S$  also forms the low-frequency response as described in [Equation 5](#).

### 9.2.3 Application Curves

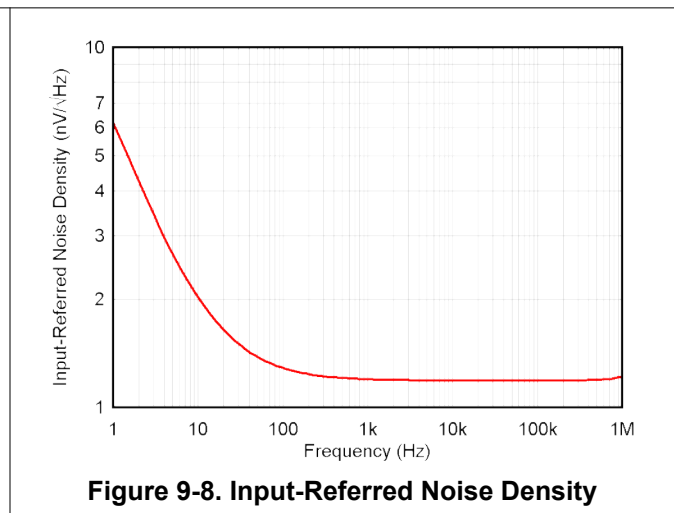
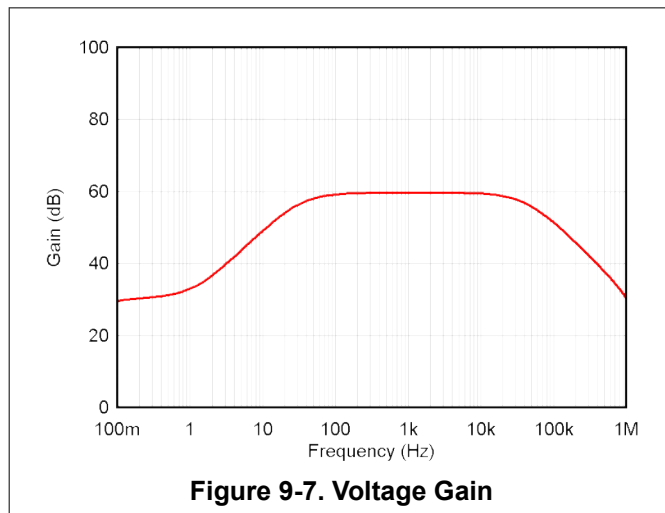

### 9.3 Power Supply Recommendations

The JFE150 is a JFET transistor with clamping diodes. There are no specific power-supply connections; however, take care not to exceed any absolute maximum voltages on any of the pins if system supply voltages greater than or equal to 40 V are used.

### 9.4 Layout

#### 9.4.1 Layout Guidelines

For best operational performance of the device, use good printed-circuit board (PCB) layout practices, including:

- Reduce parasitic coupling by running the input traces as far away from the supply or output traces as possible. If these traces cannot be kept separate, crossing the sensitive trace perpendicular is much better as opposed to in parallel with the noisy trace.
- Place the external components as close to the device as possible.
- Keep the length of input traces as short as possible. Always remember that the input traces are the most sensitive part of the circuit.
- Keep high impedance input signals away from noisy traces.
- Make sure supply voltages are adequately filtered.
- Minimize distance between source-connected and drain-connected components to the JFE150.
- Consider a driven, low-impedance guard ring around the critical gate traces. A guard ring can significantly reduce leakage currents from nearby traces that are at different potentials.
- Clean the PCB following board assembly for best performance.
- Any precision integrated circuit can experience performance shifts resulting from moisture ingress into the plastic package. Following any aqueous PCB cleaning process, bake the PCB assembly to remove moisture introduced into the device packaging during the cleaning process. A low temperature, post-cleaning bake at 85°C for 30 minutes is sufficient for most circumstances.

#### 9.4.2 Layout Example

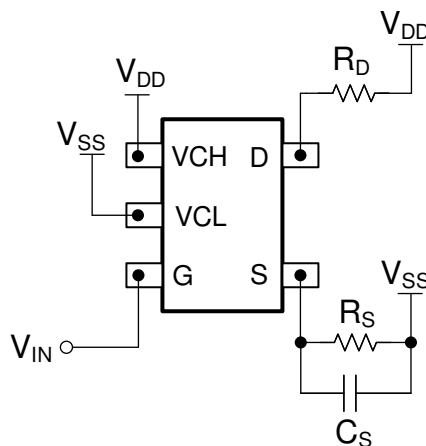

Figure 9-9. JFE150 Layout Example, Common Source Configuration

## 10 Device and Documentation Support

### 10.1 Device Support

#### 10.1.1 Development Support

##### 10.1.1.1 PSpice® for TI

PSpice® for TI is a design and simulation environment that helps evaluate performance of analog circuits. Create subsystem designs and prototype solutions before committing to layout and fabrication, reducing development cost and time to market.

##### 10.1.1.2 TINA-TI™ Simulation Software (Free Download)

TINA-TI™ simulation software is a simple, powerful, and easy-to-use circuit simulation program based on a SPICE engine. TINA-TI simulation software is a free, fully-functional version of the TINA™ software, preloaded with a library of macromodels, in addition to a range of both passive and active models. TINA-TI simulation software provides all the conventional dc, transient, and frequency domain analysis of SPICE, as well as additional design capabilities.

Available as a [free download](#) from the [Design tools and simulation](#) web page, TINA-TI simulation software offers extensive post-processing capability that allows users to format results in a variety of ways. Virtual instruments offer the ability to select input waveforms and probe circuit nodes, voltages, and waveforms, creating a dynamic quick-start tool.

---

#### Note

These files require that either the TINA software or TINA-TI software be installed. Download the free TINA-TI simulation software from the [TINA-TI™ software folder](#).

---

##### 10.1.1.3 TI Reference Designs

TI reference designs are analog solutions created by TI's precision analog applications experts. TI reference designs offer the theory of operation, component selection, simulation, complete PCB schematic and layout, bill of materials, and measured performance of many useful circuits. TI reference designs are available online at <https://www.ti.com/reference-designs>.

##### 10.1.1.4 Filter Design Tool

The [filter design tool](#) is a simple, powerful, and easy-to-use active filter design program. The filter design tool allows the user to create optimized filter designs using a selection of TI operational amplifiers and passive components from TI's vendor partners.

Available as a web-based tool from the [Design tools and simulation](#) web page, the [filter design tool](#) allows the user to design, optimize, and simulate complete multistage active filter solutions within minutes.

## 10.2 Documentation Support

### 10.2.1 Related Documentation

For related documentation see the following:

- Texas Instruments, [JFE150 Ultra-Low-Noise Pre-Amp application note](#)
- Texas Instruments, [JFE150 Evaluation Module user's guide](#)
- Texas Instruments, [OPAx202 Precision, Low-Noise, Heavy Capacitive Drive, 36-V Operational Amplifiers data sheet](#)
- Texas Instruments, [OPAx210 2.2-nV/√Hz Precision, Low-Power, 36-V Operational Amplifiers data sheet](#)

### 10.3 Receiving Notification of Documentation Updates

To receive notification of documentation updates, navigate to the device product folder on [ti.com](#). Click on *Subscribe to updates* to register and receive a weekly digest of any product information that has changed. For change details, review the revision history included in any revised document.

### 10.4 Support Resources

[TI E2E™ support forums](#) are an engineer's go-to source for fast, verified answers and design help — straight from the experts. Search existing answers or ask your own question to get the quick design help you need.

Linked content is provided "AS IS" by the respective contributors. They do not constitute TI specifications and do not necessarily reflect TI's views; see TI's [Terms of Use](#).

### 10.5 Trademarks

Burr-Brown™, TINA-TI™, and TI E2E™ are trademarks of Texas Instruments.

TINA™ is a trademark of DesignSoft, Inc.

PSPICE® is a registered trademark of Cadence Design Systems, Inc.

All trademarks are the property of their respective owners.

### 10.6 Electrostatic Discharge Caution



This integrated circuit can be damaged by ESD. Texas Instruments recommends that all integrated circuits be handled with appropriate precautions. Failure to observe proper handling and installation procedures can cause damage.

ESD damage can range from subtle performance degradation to complete device failure. Precision integrated circuits may be more susceptible to damage because very small parametric changes could cause the device not to meet its published specifications.

### 10.7 Glossary

[TI Glossary](#) This glossary lists and explains terms, acronyms, and definitions.

## 11 Mechanical, Packaging, and Orderable Information

The following pages include mechanical, packaging, and orderable information. This information is the most current data available for the designated devices. This data is subject to change without notice and revision of this document. For browser-based versions of this data sheet, refer to the left-hand navigation.

## PACKAGING INFORMATION

Orderable Device	Status (1)	Package Type	Package Drawing	Pins	Package Qty	Eco Plan (2)	Lead finish/ Ball material (6)	MSL Peak Temp (3)	Op Temp (°C)	Device Marking (4/5)	Samples
JFE150DBVR	ACTIVE	SOT-23	DBV	5	3000	RoHS & Green	NIPDAU	Level-1-260C-UNLIM	-40 to 125	2GLW	<a href="#">Samples</a>
JFE150DBVT	ACTIVE	SOT-23	DBV	5	250	RoHS & Green	NIPDAU	Level-1-260C-UNLIM	-40 to 125	2GLW	<a href="#">Samples</a>
JFE150DCKR	ACTIVE	SC70	DCK	5	3000	RoHS & Green	SN	Level-1-260C-UNLIM	-40 to 125	11F	<a href="#">Samples</a>
JFE150DCKT	ACTIVE	SC70	DCK	5	250	RoHS & Green	SN	Level-1-260C-UNLIM	-40 to 125	11F	<a href="#">Samples</a>

(1) The marketing status values are defined as follows:

**ACTIVE:** Product device recommended for new designs.

**LIFEBUY:** TI has announced that the device will be discontinued, and a lifetime-buy period is in effect.

**NRND:** Not recommended for new designs. Device is in production to support existing customers, but TI does not recommend using this part in a new design.

**PREVIEW:** Device has been announced but is not in production. Samples may or may not be available.

**OBSOLETE:** TI has discontinued the production of the device.

(2) **RoHS:** TI defines "RoHS" to mean semiconductor products that are compliant with the current EU RoHS requirements for all 10 RoHS substances, including the requirement that RoHS substance do not exceed 0.1% by weight in homogeneous materials. Where designed to be soldered at high temperatures, "RoHS" products are suitable for use in specified lead-free processes. TI may reference these types of products as "Pb-Free".

**RoHS Exempt:** TI defines "RoHS Exempt" to mean products that contain lead but are compliant with EU RoHS pursuant to a specific EU RoHS exemption.

**Green:** TI defines "Green" to mean the content of Chlorine (Cl) and Bromine (Br) based flame retardants meet JS709B low halogen requirements of <=1000ppm threshold. Antimony trioxide based flame retardants must also meet the <=1000ppm threshold requirement.

(3) MSL, Peak Temp. - The Moisture Sensitivity Level rating according to the JEDEC industry standard classifications, and peak solder temperature.

(4) There may be additional marking, which relates to the logo, the lot trace code information, or the environmental category on the device.

(5) Multiple Device Markings will be inside parentheses. Only one Device Marking contained in parentheses and separated by a "-" will appear on a device. If a line is indented then it is a continuation of the previous line and the two combined represent the entire Device Marking for that device.

(6) Lead finish/Ball material - Orderable Devices may have multiple material finish options. Finish options are separated by a vertical ruled line. Lead finish/Ball material values may wrap to two lines if the finish value exceeds the maximum column width.

**Important Information and Disclaimer:**The information provided on this page represents TI's knowledge and belief as of the date that it is provided. TI bases its knowledge and belief on information provided by third parties, and makes no representation or warranty as to the accuracy of such information. Efforts are underway to better integrate information from third parties. TI has taken and

continues to take reasonable steps to provide representative and accurate information but may not have conducted destructive testing or chemical analysis on incoming materials and chemicals. TI and TI suppliers consider certain information to be proprietary, and thus CAS numbers and other limited information may not be available for release.

In no event shall TI's liability arising out of such information exceed the total purchase price of the TI part(s) at issue in this document sold by TI to Customer on an annual basis.

**TAPE AND REEL INFORMATION**

**QUADRANT ASSIGNMENTS FOR PIN 1 ORIENTATION IN TAPE**

\*All dimensions are nominal

Device	Package Type	Package Drawing	Pins	SPQ	Reel Diameter (mm)	Reel Width W1 (mm)	A0 (mm)	B0 (mm)	K0 (mm)	P1 (mm)	W (mm)	Pin1 Quadrant
JFE150DBVR	SOT-23	DBV	5	3000	180.0	8.4	3.2	3.2	1.4	4.0	8.0	Q3
JFE150DBVT	SOT-23	DBV	5	250	180.0	8.4	3.2	3.2	1.4	4.0	8.0	Q3
JFE150DCKR	SC70	DCK	5	3000	178.0	9.0	2.4	2.5	1.2	4.0	8.0	Q3
JFE150DCKT	SC70	DCK	5	250	178.0	9.0	2.4	2.5	1.2	4.0	8.0	Q3

**TAPE AND REEL BOX DIMENSIONS**

\*All dimensions are nominal

Device	Package Type	Package Drawing	Pins	SPQ	Length (mm)	Width (mm)	Height (mm)
JFE150DBVR	SOT-23	DBV	5	3000	210.0	185.0	35.0
JFE150DBVT	SOT-23	DBV	5	250	210.0	185.0	35.0
JFE150DCKR	SC70	DCK	5	3000	180.0	180.0	18.0
JFE150DCKT	SC70	DCK	5	250	180.0	180.0	18.0



# EXAMPLE BOARD LAYOUT

DBV0005A

SOT-23 - 1.45 mm max height

SMALL OUTLINE TRANSISTOR



LAND PATTERN EXAMPLE  
EXPOSED METAL SHOWN  
SCALE:15X



SOLDER MASK DETAILS

4214839/J 02/2024

NOTES: (continued)

- 6. Publication IPC-7351 may have alternate designs.
- 7. Solder mask tolerances between and around signal pads can vary based on board fabrication site.

# EXAMPLE STENCIL DESIGN

DBV0005A

SOT-23 - 1.45 mm max height

SMALL OUTLINE TRANSISTOR



SOLDER PASTE EXAMPLE  
BASED ON 0.125 mm THICK STENCIL  
SCALE:15X

4214839/J 02/2024

NOTES: (continued)

8. Laser cutting apertures with trapezoidal walls and rounded corners may offer better paste release. IPC-7525 may have alternate design recommendations.
9. Board assembly site may have different recommendations for stencil design.

# DCK0005A



## PACKAGE OUTLINE

SOT - 1.1 max height

SMALL OUTLINE TRANSISTOR

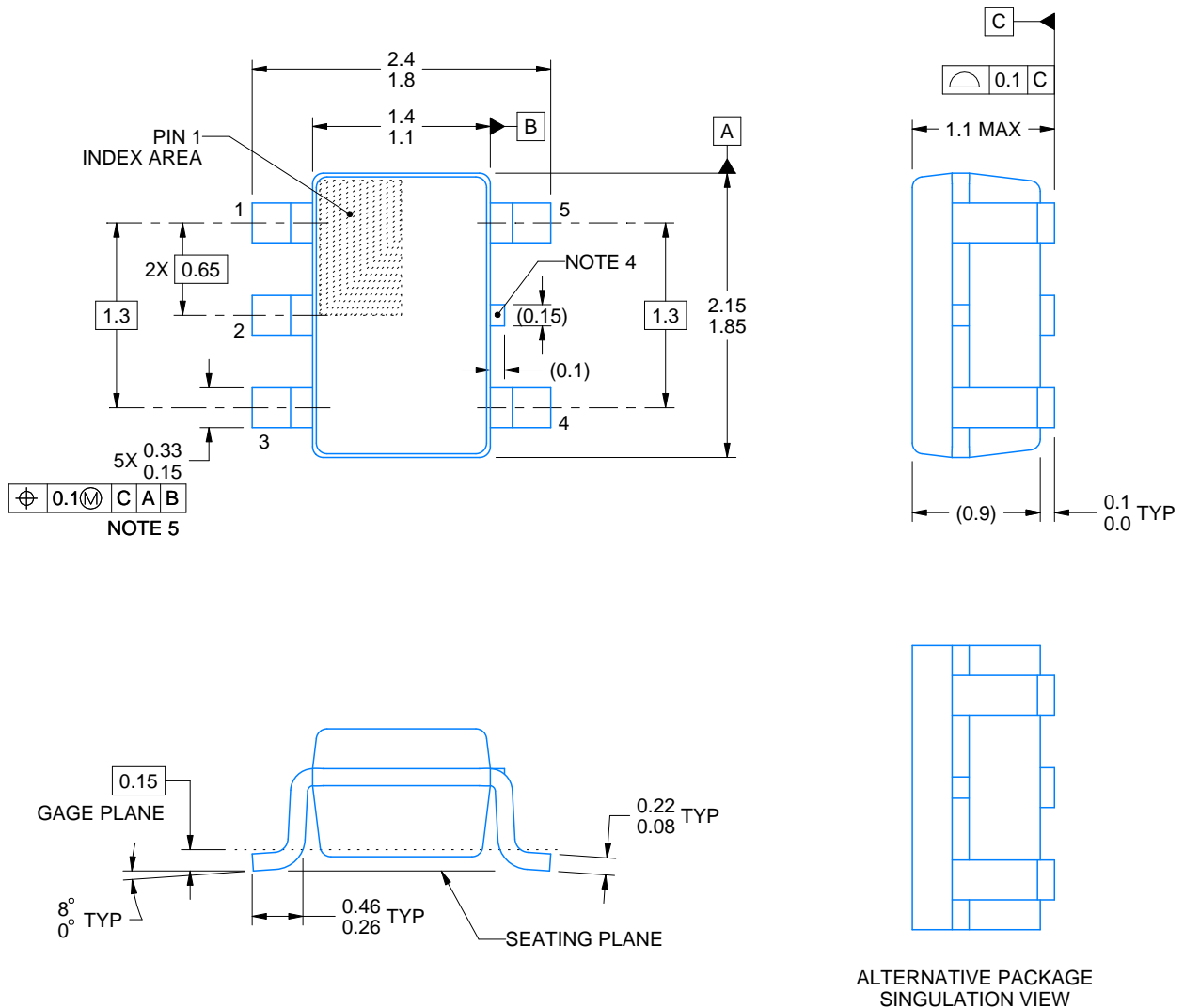

4214834/E 06/2024

### NOTES:

1. All linear dimensions are in millimeters. Any dimensions in parenthesis are for reference only. Dimensioning and tolerancing per ASME Y14.5M.
2. This drawing is subject to change without notice.
3. Reference JEDEC MO-203.
4. Support pin may differ or may not be present.
5. Lead width does not comply with JEDEC.
6. Body dimensions do not include mold flash, protrusions, or gate burrs. Mold flash, protrusions, or gate burrs shall not exceed 0.25mm per side

# EXAMPLE BOARD LAYOUT

DCK0005A

SOT - 1.1 max height

SMALL OUTLINE TRANSISTOR

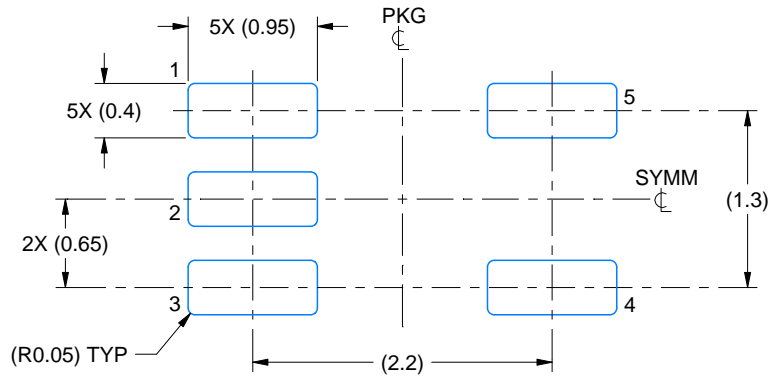

LAND PATTERN EXAMPLE  
EXPOSED METAL SHOWN  
SCALE:18X

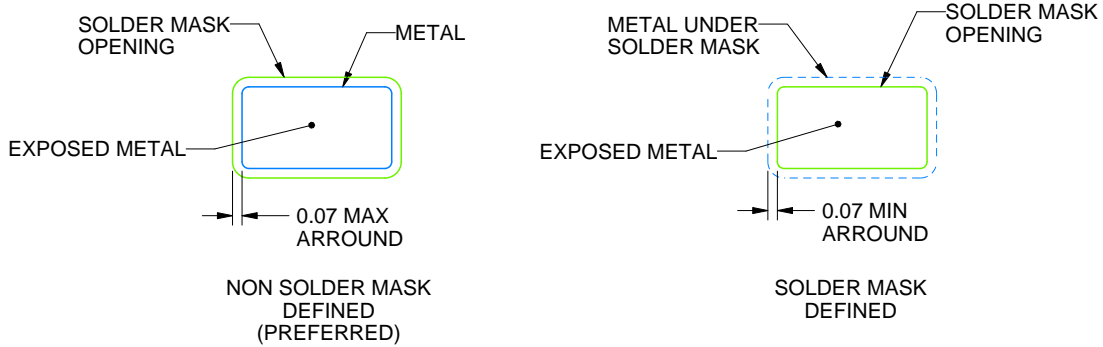

SOLDER MASK DETAILS

4214834/E 06/2024

NOTES: (continued)

- 7. Publication IPC-7351 may have alternate designs.
- 8. Solder mask tolerances between and around signal pads can vary based on board fabrication site.

# EXAMPLE STENCIL DESIGN

DCK0005A

SOT - 1.1 max height

SMALL OUTLINE TRANSISTOR

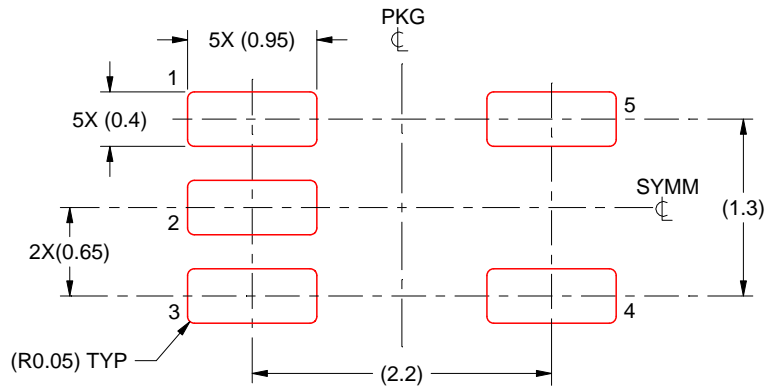

SOLDER PASTE EXAMPLE  
BASED ON 0.125 THICK STENCIL  
SCALE: 18X

4214834/E 06/2024

NOTES: (continued)

9. Laser cutting apertures with trapezoidal walls and rounded corners may offer better paste release. IPC-7525 may have alternate design recommendations.
10. Board assembly site may have different recommendations for stencil design.

## IMPORTANT NOTICE AND DISCLAIMER

TI PROVIDES TECHNICAL AND RELIABILITY DATA (INCLUDING DATA SHEETS), DESIGN RESOURCES (INCLUDING REFERENCE DESIGNS), APPLICATION OR OTHER DESIGN ADVICE, WEB TOOLS, SAFETY INFORMATION, AND OTHER RESOURCES "AS IS" AND WITH ALL FAULTS, AND DISCLAIMS ALL WARRANTIES, EXPRESS AND IMPLIED, INCLUDING WITHOUT LIMITATION ANY IMPLIED WARRANTIES OF MERCHANTABILITY, FITNESS FOR A PARTICULAR PURPOSE OR NON-INFRINGEMENT OF THIRD PARTY INTELLECTUAL PROPERTY RIGHTS.

These resources are intended for skilled developers designing with TI products. You are solely responsible for (1) selecting the appropriate TI products for your application, (2) designing, validating and testing your application, and (3) ensuring your application meets applicable standards, and any other safety, security, regulatory or other requirements.

These resources are subject to change without notice. TI grants you permission to use these resources only for development of an application that uses the TI products described in the resource. Other reproduction and display of these resources is prohibited. No license is granted to any other TI intellectual property right or to any third party intellectual property right. TI disclaims responsibility for, and you will fully indemnify TI and its representatives against, any claims, damages, costs, losses, and liabilities arising out of your use of these resources.

TI's products are provided subject to [TI's Terms of Sale](#) or other applicable terms available either on [ti.com](https://www.ti.com) or provided in conjunction with such TI products. TI's provision of these resources does not expand or otherwise alter TI's applicable warranties or warranty disclaimers for TI products.

TI objects to and rejects any additional or different terms you may have proposed.

Mailing Address: Texas Instruments, Post Office Box 655303, Dallas, Texas 75265  
Copyright © 2024, Texas Instruments Incorporated

## Looking for pricing, stock, or lifecycle information?

Click below to explore more details on WIN SOURCE:

 [View JFE150DCKT](#) on WIN SOURCE

 [Texas Instruments](#) Information

## Optimize Your Supply Chain with WIN SOURCE Solutions

-  Global Sourcing Solution
-  Obsolete Management
-  Cost Control Management
-  Shortage Management
-  Alternative Solution
-  Excess Inventory Management