

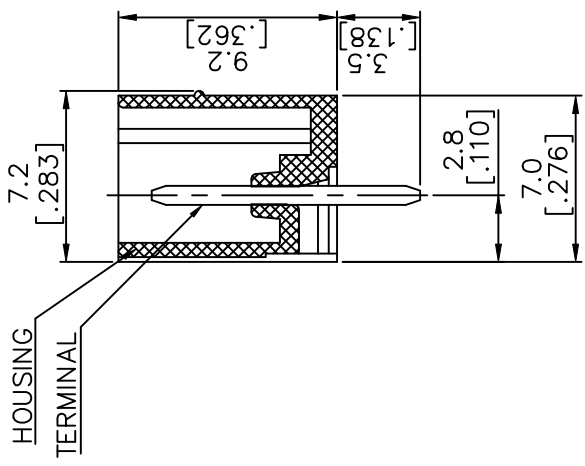

**THE DATASHEET OF
OQ041250000G**

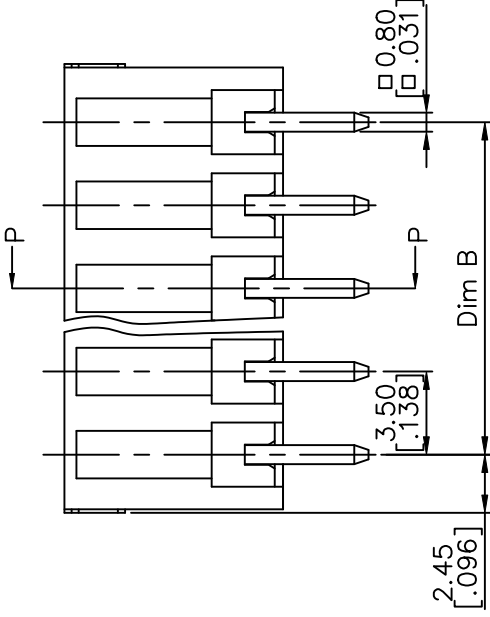

PRODUCT NUMBER	SERIES NAME	PITCH
20020107-CXXXXXXLF	06-350	3.50 mm

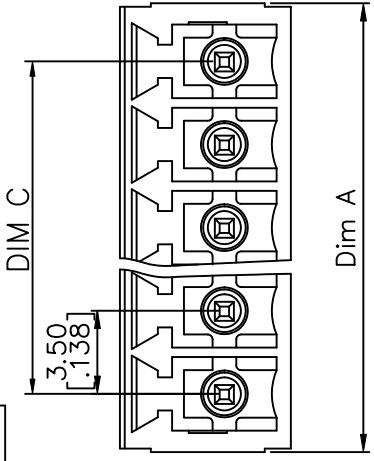

SECTION P-P

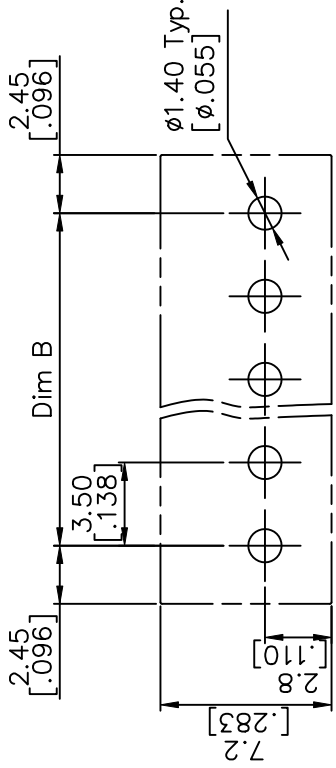

RECOMMENDED P.C.B LAYOUT

mat'l. code	surface	tolerances unless	angles	dr	engr	chr	appd
itr	ASME Y14.5		X.X	BEER FU	BEER FU	GARY HSI	JOSEPH HS
ecn no			X.X				
dr			X.X				
en							
chr							
appd							
sheet	revision						
index	sheet						

PRODUCT NUMBER	SERIES NAME	PITCH
20020107-DXXXXXXLF	06-381	3.81 mm

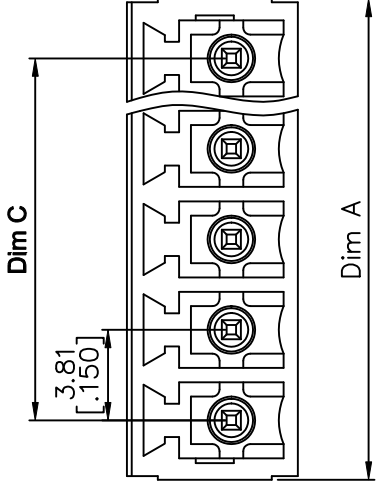

HOUSING
TERMINAL

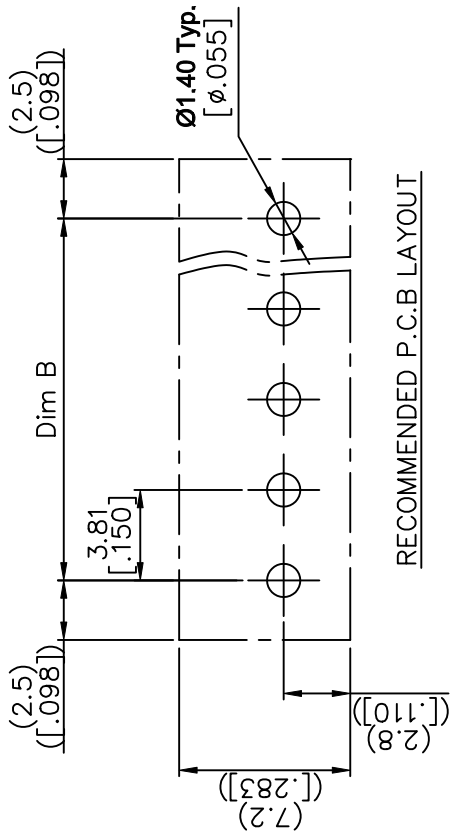

RECOMMENDED P.C.B LAYOUT

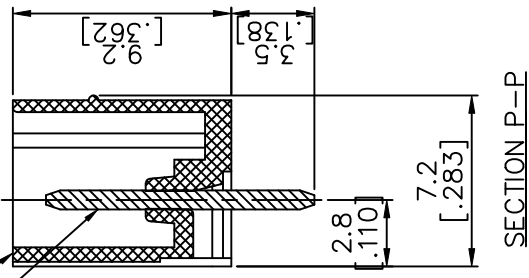

SECTION P-P

mat'l. code	tr	ecn	no	dr	date	surface	tc
	k					ASME Y14.5	A
						tolerances unless	
						angles	X.
						X±1°	X.XX
						dr	BEER FU
						engr	BEER FU
						chr	GARY HSI
						appd	JOSEPH HS
	sheet	revision					
	index	sheet					

PRODUCT NUMBER	SERIES NAME	PITCH
20020107-HXXXXXLF	06-508	5.08 mm

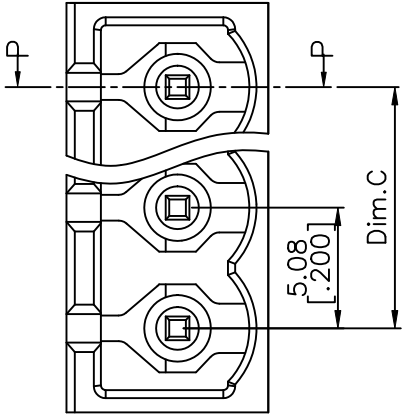

N = NUM	DIMENSIO
Dim A	N
Dim B	(0
Dim C	(0
Poles	
2p-6p	
7p-12	
13p-11	
17p-2	

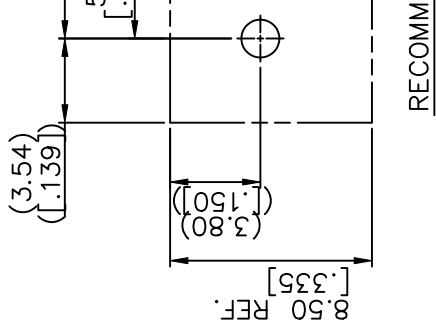
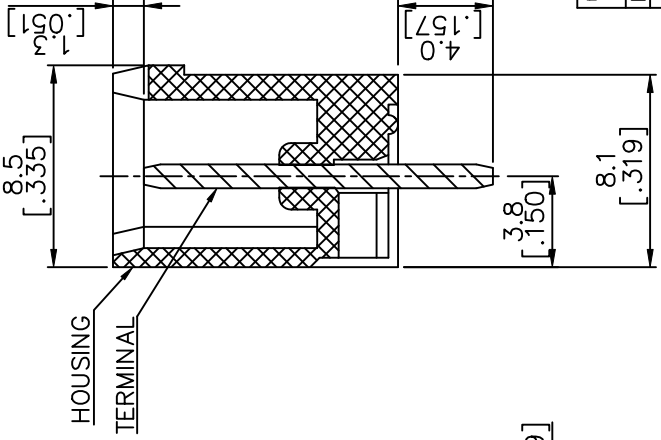
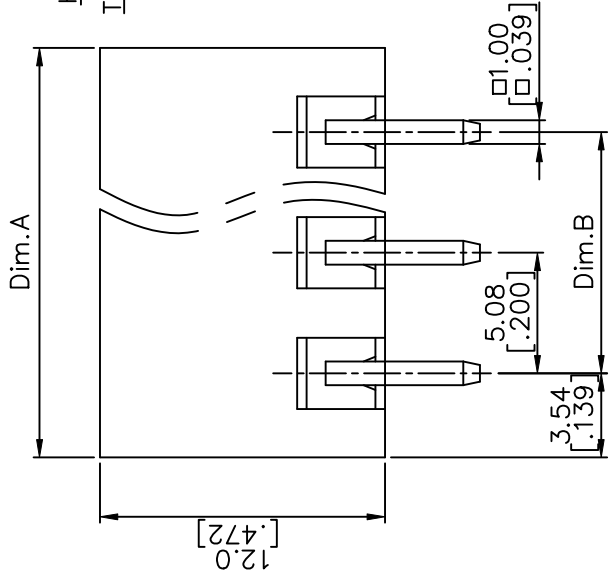



RECOMM

mat'l. code	tr	ecn	no	dr	date	surface	tc
	k					ASME Y14.5	ASME Y14.5
						tolerances unless	tolerances unless
						angles	angles
						X±1*	X.X
						X±1*	X.XX
						dr	BEER FU
						engr	BEER FU
						chr	GARY HSIEN
						appd	JOSEPH HS
	sheet	revision					
	index	sheet					

Looking for pricing, stock, or lifecycle information?

Click below to explore more details on WIN SOURCE:

-  [View OQ0412500000G on WIN SOURCE](#)
-  [Amphenol Anytek Information](#)

Optimize Your Supply Chain with WIN SOURCE Solutions

-  Global Sourcing Solution
-  Obsolete Management
-  Cost Control Management
-  Shortage Management
-  Alternative Solution
-  Excess Inventory Management