



**THE DATASHEET OF
BU27006MUC-ZTR**



Color Sensor IC Series

Digital 16bit Serial Output Type Color Sensor IC

BU27006MUC-Z

General Description

BU27006MUC-Z is a digital color sensor IC with Flicker sensing function. This IC senses Red, Green, Blue (RGB) and Infrared and converts them to digital values. The high sensitivity, wide dynamic range and excellent Ircut characteristics make it possible for this IC to obtain the accurate illuminance and color temperature of ambient light. It is also possible to detect flicker light noise of display and room lighting. It is ideal for adjusting LCD backlight of TV, mobile phone and tablet PC.

Features

- RGB/IR + Flicker Detection
- Built-in Ircut Filter
- Rejecting 50 Hz/60 Hz Light Noise for Color Sensor
- I²C Bus Interface (f/s mode support)
- Correspond to 1.8 V Logic Interface
- LUX Resolution 0.015 lx/count (Typ) in Color Sensor (In the highest gain and the longest measurement time setting)
- Sampling frequency 1 kHz/2 kHz is selectable in flicker sensor

Key Specifications

- VCC Voltage Range: 1.7 V to 3.6 V
- LUX and CCT Detection Range^(Note 1): 50 lx (Typ)
- Flicker Detection Range^(Note 1): 10 klx (Typ)
- Current Consumption^(Note 1):
 - Color Sensing: 220 μA (Typ)
 - Flicker Sensing: 200 μA (Typ)
- Power Down Current: 2 μA (Typ)
- Operating Temperature Range: -40 °C to +85 °C
(Note 1) White LED is used.

Package

WQFN12X2520A

W (Typ) x D (Typ) x H (Max)

2.50 mm x 2.00 mm x 0.55 mm

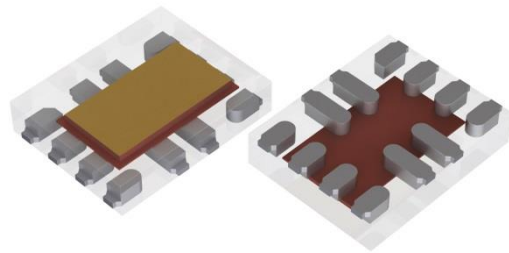

Applications

Mobile Phone, Tablet PC, Notebook PC, Digital Camera, Portable Game Machine, LCD TV

Typical Application Circuits

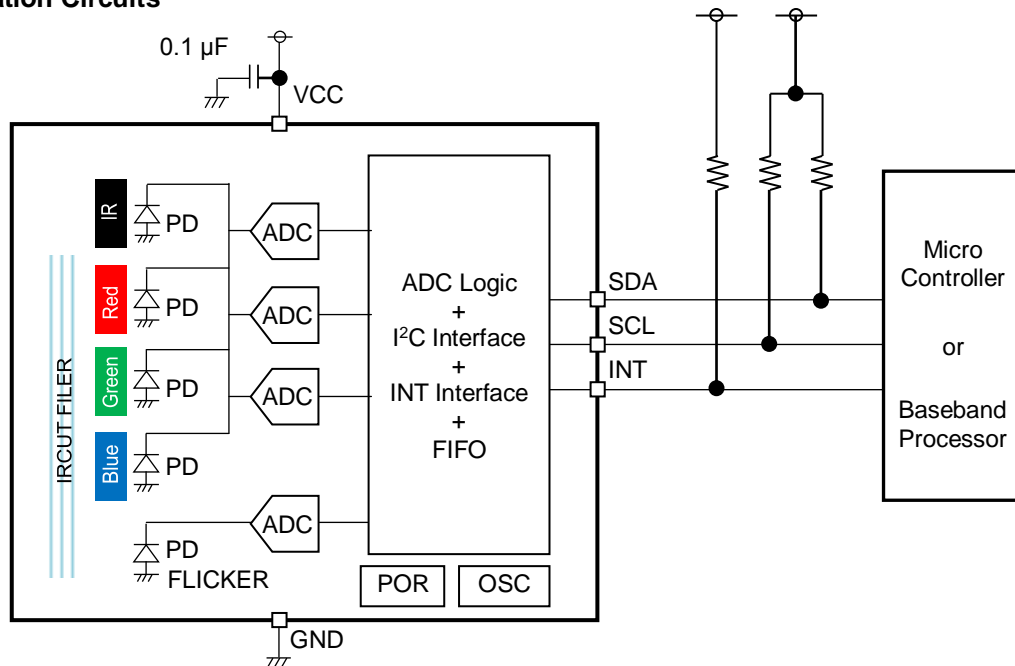

○Product structure: Silicon integrated circuit
 ○This product does not include laser transmitter.
 ○This product includes Photo detector, (Photo Diode) inside of it.

○This product has no designed protection against radioactive rays.
 ○This product does not include optical load.

Pin Configuration

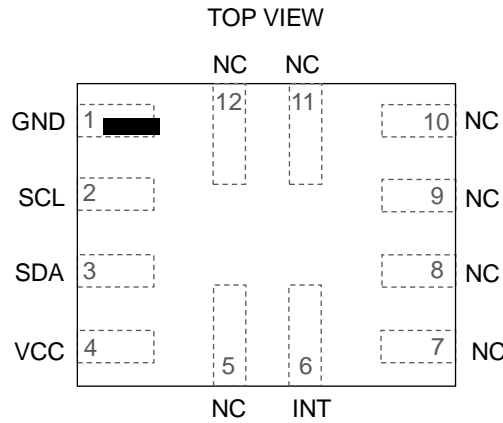

Pin Description

Pin No.	Pin Name	Function
1	GND	Ground
2	SCL	I ² C bus serial clock ^(Note 1)
3	SDA	I ² C bus serial data ^(Note 1)
4	VCC	Power supply ^(Note 2)
6	INT	Interrupt ^(Note 1)
5, 7 to 12	NC	Non connect ^(Note 3)

(Note 1) If there is a device falls sharply among other devices connected to the SDA, SCL, and INT pins, it might generate undershoot and the pin voltage might be the ground potential or below. When the undershoot occurs, must take a measure like adding a capacitor near to the pin of the device concerned.

(Note 2) Dispose a bypass capacitor as close as possible to the IC

(Note 3) Please use the NC pin as open pin

Block Diagram

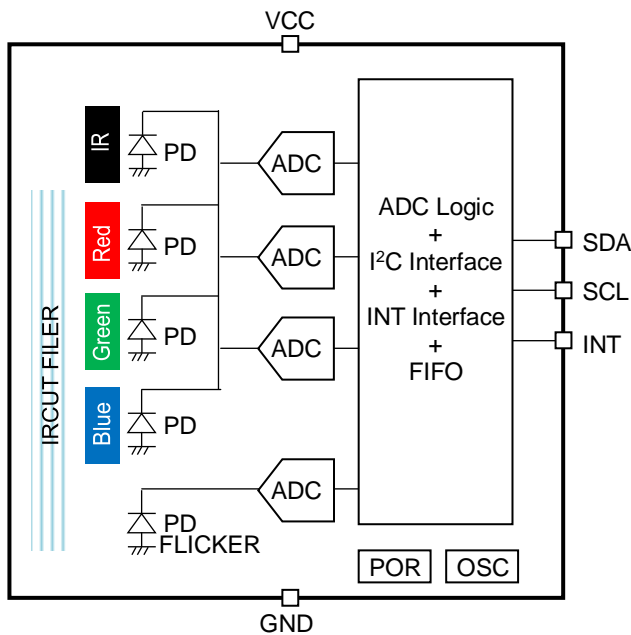

Description of Blocks

- IR CUT FILTER : Infrared cut filter
- RED, GREEN, BLUE, IR : Red, Green, Blue, Infrared pass filter
- PD : Photodiode
- ADC : Analog-to-Digital Converter for obtaining 16 bit digital data depending on quantity of the light.
- ADC Logic + I²C Interface + INT Interface + FIFO : ADC control logic and I/F logic + FIFO (for Flicker function)
- OSC : Clock generator for internal logic
- POR : Power ON Reset. All registers are reset after VCC is supplied.

Absolute Maximum Ratings (Ta = 25 °C)

Parameter	Symbol	Rating	Unit
Supply Voltage	V _{CC_MR}	4.5	V
Input Voltage [INT,SCL,SDA]	V _{IN_MR}	-0.3 to +4.5	V
Storage Temperature Range	T _{stg}	-40 to +100	°C
Maximum Junction Temperature	T _{jmax}	100	°C

Caution 1: Operating the IC over the absolute maximum ratings may damage the IC. The damage can either be a short circuit between pins or an open circuit between pins and the internal circuitry. Therefore, it is important to consider circuit protection measures, such as adding a fuse, in case the IC is operated over the absolute maximum ratings.

Caution 2: Should by any chance the maximum junction temperature rating be exceeded the rise in temperature of the chip may result in deterioration of the properties of the chip. In case of exceeding this absolute maximum rating, design a PCB with thermal resistance taken into consideration by increasing board size and copper area so as not to exceed the maximum junction temperature rating.

Thermal Resistance^(Note 1)

Parameter	Symbol	Thermal Resistance (Typ)		Unit
		1s ^(Note 3)	2s2p ^(Note 4)	
WQFN12X2520A				
Junction to Ambient	θ_{JA}	220.6	126.9	°C/W
Junction to Top Characterization Parameter ^(Note 2)	Ψ_{JT}	42	38	°C/W

(Note 1) Based on JESD51-2A(Still-Air).

(Note 2) The thermal characterization parameter to report the difference between junction temperature and the temperature at the top center of the outside surface of the component package.

(Note 3) Using a PCB board based on JESD51-3.

(Note 4) Using a PCB board based on JESD51-7.

Layer Number of Measurement Board	Material	Board Size
Single	FR-4	114.3 mm x 76.2 mm x 1.6 mmt

Top	
Copper Pattern	Thickness
Footprints and Traces	70 μ m

Layer Number of Measurement Board	Material	Board Size
4 Layers	FR-4	114.3 mm x 76.2 mm x 1.6 mmt

Top		2 Internal Layers		Bottom	
Copper Pattern	Thickness	Copper Pattern	Thickness	Copper Pattern	Thickness
Footprints and Traces	70 μ m	74.2 mm x 74.2 mm	35 μ m	74.2 mm x 74.2 mm	70 μ m

Recommended Operating Conditions

Parameter	Symbol	Min	Typ	Max	Unit
Operating Temperature	T _{opr}	-40	+25	+85	°C
Supply Voltage	V _{CC}	1.7	1.8	3.6	V
Input Voltage [INT,SCL,SDA]	V _{IN}	0	-	3.6	V

Electrical Characteristics

(Unless otherwise specified, V_{CC} = 1.8 V, Ta = 25 °C, RGB_GAIN = x32 gain mode, MEAS_MODE = 100 ms mode, FLC_GAIN = x32 gain mode, FLC_MODE = 2 kHz mode)

Parameter	Symbol	Min	Typ	Max	Unit	Conditions
Current Consumption 1	I _{CC1}	-	220	310	μA	Ev = 300 lx ^(Note 1) RGB_EN = '1', FLC_EN = '0'
Current Consumption 2	I _{CC2}	-	200	280	μA	Ev = 300 lx ^(Note 1) RGB_EN = '0', FLC_EN = '1'
Power Down Current	I _{CC3}	-	2	5	μA	No input light RGB_EN = '0', FLC_EN = '0' SCL = SDA = 1.8 V ^(Note 2)
Red Data Count Value	D _{RED}	2040	2400	2760	count	Ev = 20 μW/cm ² ^(Note 3)
Green Data Count Value	D _{GREEN}	2975	3500	4025	count	Ev = 20 μW/cm ² ^(Note 4)
Blue Data Count Value	D _{BLUE}	1785	2100	2415	count	Ev = 20 μW/cm ² ^(Note 5)
IR Data Count Value	D _{IR}	560	750	940	count	Ev = 20 μW/cm ² ^(Note 6)
Flicker Data Count Value	D _{FLICKER}	370	500	630	count	Ev = 300 lx ^(Note 1)
RGB/IR Dark Count Value	S _{0_0}	-	-	2	count	No input light
FLICKER Dark Count Value	S _{F_0}	-	-	5	count	No input light
RGB/IR Measurement Time	t _{MT}	-	-	100	ms	
FLICKER Measurement Time	t _{FLC}	475	500	525	μs	
INT Output 'L' Voltage	V _{INTL}	0	-	0.4	V	I _{OL} = 3 mA
SCL SDA Input 'H' Voltage	V _{IH}	0.84	-	-	V	
SCL SDA Input 'L' Voltage	V _{IL}	-	-	0.45	V	
SDA Output 'L' Voltage	V _{OL}	0	-	0.4	V	I _{OL} = 3 mA

(Note 1) White LED is used.
 (Note 2) Current value depends on the voltage difference between the VCC pin and the SCL or SDA pins.
 (Note 3) Red LED is used.
 (Note 4) Green LED is used.
 (Note 5) Blue LED is used.
 (Note 6) Infrared LED is used.

Typical Performance Curves

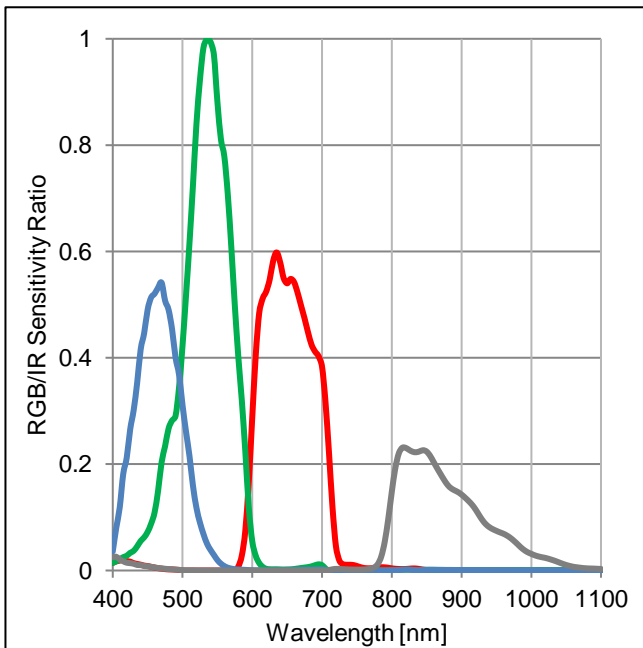

Figure 1. RGB/IR Sensitivity Ratio vs Wavelength (RGB/IR Spectral Response)

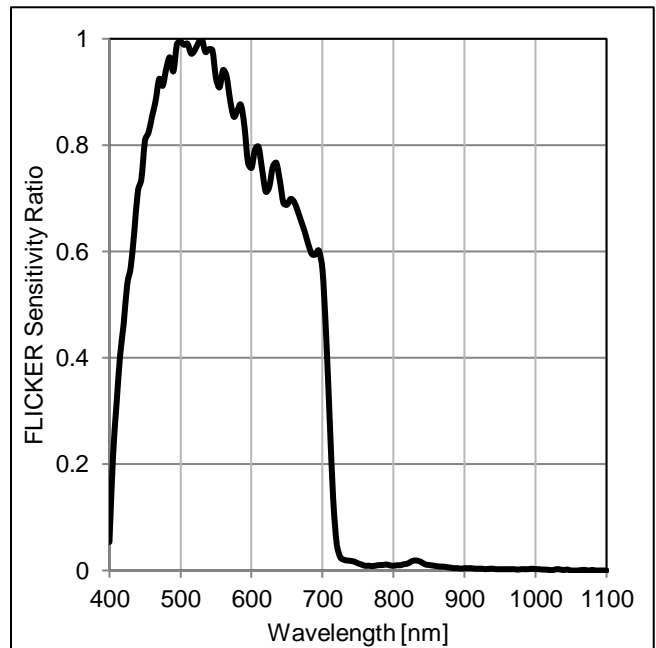
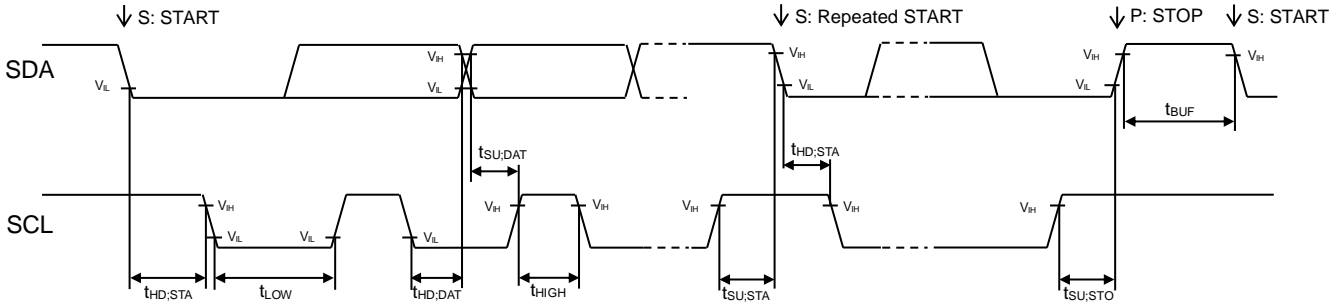

Figure 2. FLICKER Sensitivity Ratio vs Wavelength (FLICKER Spectral Response)

I²C Bus Timing Characteristics (Unless otherwise specified V_{CC} = 1.8 V, Ta = 25 °C)



Parameter	Symbol	Min	Typ	Max	Unit
SCL Clock Frequency	f _{SCL}	0	-	400	kHz
'L' Period of the SCL Clock	t _{LOW}	1.3	-	-	μs
'H' Period of the SCL Clock	t _{HIGH}	0.6	-	-	μs
Setup Time for Repeated START	t _{SU,STA}	0.6	-	-	μs
Hold Time for START	t _{HD,STA}	0.6	-	-	μs
Data Setup Time	t _{SU,DAT}	100	-	-	ns
Data Hold Time	t _{HD,DAT}	0	-	-	μs
Setup Time for STOP	t _{SU,STO}	0.6	-	-	μs
Bus Free Time between STOP and START	t _{BUF}	1.3	-	-	μs

I²C Bus Communication

1. Write Format

(1) Indicate register address

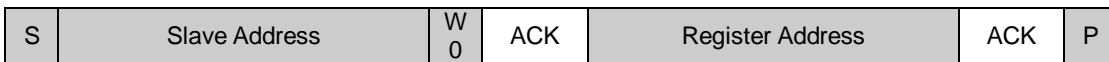

(2) Write data after indicating register address

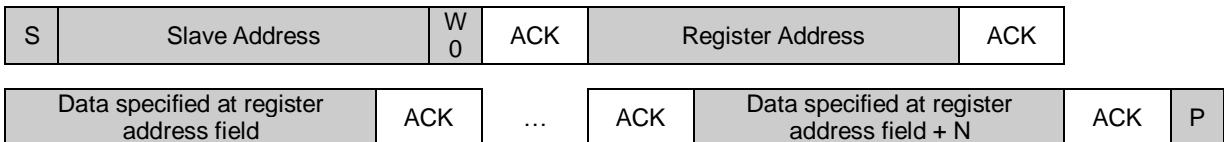

2. Read Format

(1) Read data after indicating register address

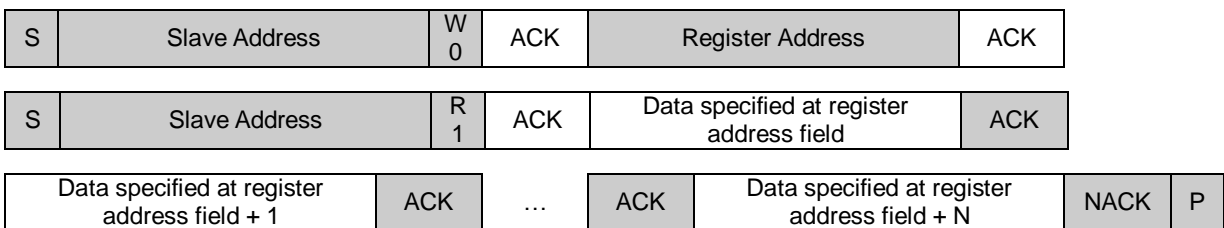

(2) Read data from the specified register

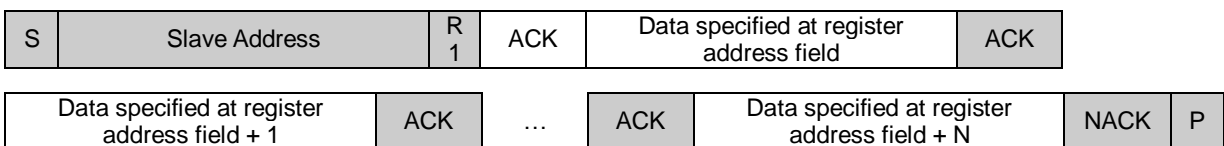

: from master to slave : from slave to master

I2C Bus Slave Address

The slave address is "0111000".

Register MAP(Note 1)

Register Address	Register Name	R/W	D7	D6	D5	D4	D3	D2	D1	D0
0x40	SYSTEM_CONTROL	RW	SW_RESET	0	PART ID					
0x41	MODE_CONTROL1	RW	0	0	RGB_GAIN		0	0	MEAS_MODE	
0x42	MODE_CONTROL2	RW	0	0	FLC_GAIN			0	0	FLC_MODE
0x43	MODE_CONTROL3	RW	RGB_VALID	FLC_VALID	0	0	INT SEL		RGB_EN	FLC_EN
0x50	RED_DATA	R	RED_DATA [7:0]							
0x51		R	RED_DATA [15:8]							
0x52	GREEN_DATA	R	GREEN_DATA [7:0]							
0x53		R	GREEN_DATA [15:8]							
0x54	BLUE_DATA	R	BLUE_DATA [7:0]							
0x55		R	BLUE_DATA [15:8]							
0x56	IR_DATA	R	IR_DATA [7:0]							
0x57		R	IR_DATA [15:8]							
0x58	FLICKER_DATA	R	FLICKER_DATA [7:0]							
0x59		R	0	0	0	FLICKER_DATA [12:8]				
0x5A	FLICKER_COUNTER	R	FLICKER_COUNTER [7:0]							
0x5B	FIFO_LEVEL	R	0	FIFO_LEVEL [6:0]						
0x5C	FIFO_DATA	R	FIFO_DATA [7:0]							
0x5D	FIFO_DATA	R	0	0	0	FIFO_DATA [12:8]				
0x92	MANUFACTURER_ID	R	MANUFACTURER_ID							

(Note 1) Do not write any commands to other addresses except above. Do not write '1' to the field in which value is '0' in above table.

(0x40) SYSTEM_CONTROL

Fields	Function
SW_RESET	All registers are reset and this IC is in power down state by software reset. 0: Software reset is not done. 1: Software reset is done.
PART ID	Part ID 0x10 (Read only register)

Default value 0x10

Register MAP - continued

(0x41) MODE_CONTROL1

Fields	Function
RGB_GAIN	Gain setting for RGB/IR Data. 00: x1 gain mode 01: x4 gain mode 10: x32 gain mode 11: x128 gain mode
MEAS_MODE	Measurement mode for RGB/IR Data 00: Forbidden to use 01: 55 ms mode 10: 100 ms mode 11: Forbidden to use Measurement time is specified in Electrical Characteristics.

Default value 0x02

MEAS_MODE: When measurement mode is 55ms and RGB_GAIN is x1 or x32, maximum output of RED_DATA is 0xC800.

(0x42) MODE_CONTROL2

Fields	Function
FLC_GAIN	Gain setting for FLICKER sensor 000: x1 gain mode 001: x2 gain mode 010: x4 gain mode 011: x8 gain mode 100: x16 gain mode 101: x32 gain mode 110: Forbidden to use 111: Forbidden to use
FLC_MODE	Measurement mode for FLICKER Data 0: 1 kHz mode 1: 2 kHz mode

Default value 0x00

(0x43) MODE_CONTROL3

Fields	Function
RGB_VALID	Refer to "VALID Register"
FLC_VALID	Refer to "VALID Register"
INT_SEL	00: Disable 01: Measurement completion of RGB/IR data 10: Measurement completion of FLICKER data 11: 64 DATAs are ready in FIFO.
RGB_EN	0: RGB/IR measurement is inactive. 1: RGB/IR measurement is active.
FLC_EN	0: Flicker measurement is inactive. 1: Flicker measurement is active.

Default value 0x00

(0x50 / 0x51) RED_DATA

Fields	Function
RED_DATA [15:0]	RED measurement result

Default value 0x0000

(0x52 / 0x53) GREEN_DATA

Fields	Function
GREEN_DATA [15:0]	GREEN measurement result

Default value 0x0000

Register MAP - continued

(0x54 / 0x55) BLUE_DATA

Fields	Function
BLUE_DATA [15:0]	BLUE measurement result

Default value 0x0000

(0x56 / 0x57) IR_DATA

Fields	Function
IR_DATA [15:0]	IR measurement result

Default value 0x0000

(0x58 / 0x59) FLICKER_DATA

Fields	Function
FLICKER_DATA [12:0]	FLICKER measurement result ADC Dynamic range of 1 kHz mode is from 0x0000 to 0x17FF. ADC Dynamic range of 2 kHz mode is from 0x0000 to 0x07FF. When ADC is overflow, 0x1FFF is registered.

Default value 0x0000

(0x5A) FLICKER_COUNTER

Fields	Function
FLICKER_COUNTER [7:0]	Refer to "FLICKER_COUNTER Register"

Default value 0x00

(0x5B) FIFO_LEVEL

Fields	Function
FIFO_LEVEL [6:0]	Refer to "FIFO Register"

Default value 0x00

(0x5C / 0x5D) FIFO_DATA

Fields	Function
FIFO_DATA [12:0]	Refer to "FIFO Register" ADC Dynamic range of 1 kHz mode is from 0x0000 to 0x17FF. ADC Dynamic range of 2 kHz mode is from 0x0000 to 0x07FF. When ADC is overflow, 0x1FFF is registered.

Default value 0x0000

(0x92) MANUFACTURER_ID

Fields	Function
MANUFACTURER_ID	MANUFACTURER_ID: 0xE0

Default value 0xE0

VALID Register

VALID registers (RGB_VALID and FLC_VALID) are measurement data update flag. It turns to '1' when measurement data is updated.
 These registers are cleared and turn to '0' by writing MODE_CONTROL1 to MODE_CONTROL3 registers (0x41, 0x42, 0x43) or reading itself.

FLICKER_COUNTER Register

Measured number from previous sync to latest sync is in this register. It is possible to calibrate the flicker frequency by correcting the flicker sensor measurement period (t_{MEAS}).

$t_{MEAS} = t_{SYNC} / \text{FLICKER_COUNTER}$
 t_{SYNC} = Time measured by host.

This register is cleared by writing MODE_CONTROL register (0x41, 0x42, 0x43) or reading itself.
 When the measurement is done for 127 times in 128 ms, like in the figure below, t_{MEAS} is 128/127 ms.

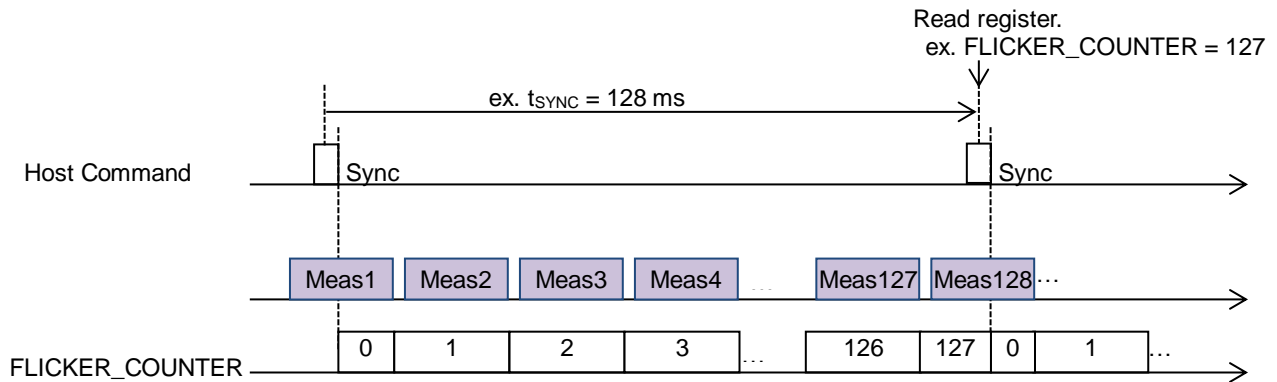

FIFO Register

There is a FIFO for FLICKER sensor. Total 100 data are possible to be stored in the FIFO. Number of stored data is written in FIFO_LEVEL register. FIFO_DATA is possible to be read continuously like in below figure.

FIFO_LEVEL register and FIFO_DATA register are cleared by writing MODE_CONTROL1 to MODE_CONTROL3 registers (0x41, 0x42, 0x43).

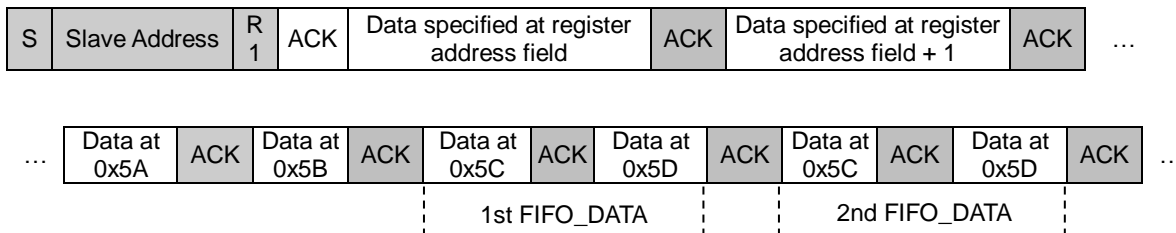

: from master to slave
 : from slave to master

Power Supply Sequence (Unless otherwise specified $V_{CC} = 1.8\text{ V}$, $T_a = 25\text{ }^\circ\text{C}$)

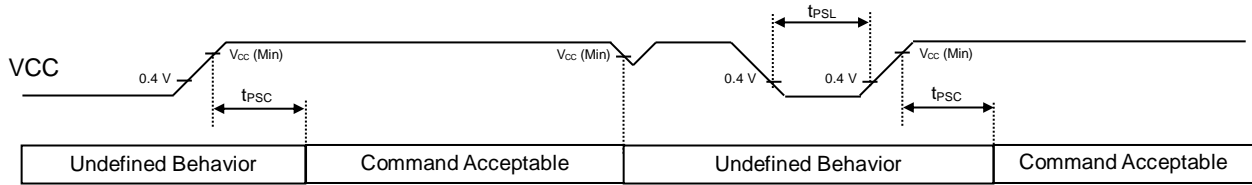

Parameter	Symbol	Min	Typ	Max	Unit	Conditions
Command Input Wait Time after Power-up	t_{PSC}	100	-	-	μs	
Power Down Time	t_{PSL}	1	-	-	ms	

Command input is available after “ t_{PSC} ” from V_{CC} is supplied.
 If V_{CC} voltage is below the recommended operating voltage range, internal state is “Undefined Behavior”. In this case, please once power down and power up again.
 Keep $V_{CC} < 0.4\text{ V}$ for “ t_{PSL} ” or more before V_{CC} is supplied again.

Optical Design for the Device

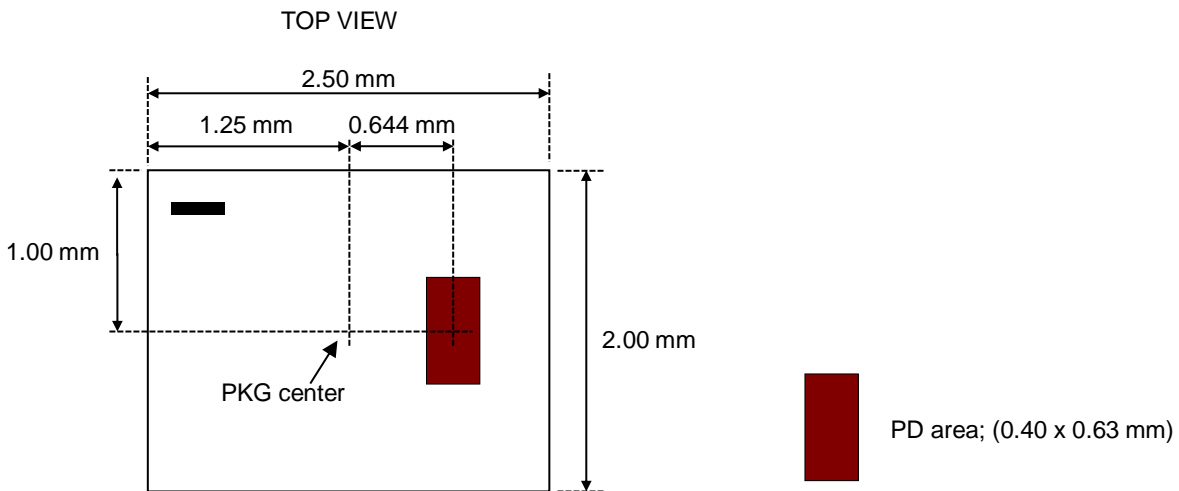

I/O Equivalence Circuits

Pin Name	Equivalent Circuit	Pin Name	Equivalent Circuit
SCL		SDA	
INT		-	-

Operational Notes

1. Reverse Connection of Power Supply

Connecting the power supply in reverse polarity can damage the IC. Take precautions against reverse polarity when connecting the power supply, such as mounting an external diode between the power supply and the IC's power supply pins.

2. Power Supply Lines

Design the PCB layout pattern to provide low impedance supply lines. Furthermore, connect a capacitor to ground at all power supply pins. Consider the effect of temperature and aging on the capacitance value when using electrolytic capacitors.

3. Ground Voltage

Ensure that no pins are at a voltage below that of the ground pin at any time, even during transient condition.

4. Ground Wiring Pattern

When using both small-signal and large-current ground traces, the two ground traces should be routed separately but connected to a single ground at the reference point of the application board to avoid fluctuations in the small-signal ground caused by large currents. Also ensure that the ground traces of external components do not cause variations on the ground voltage. The ground lines must be as short and thick as possible to reduce line impedance.

5. Recommended Operating Conditions

The function and operation of the IC are guaranteed within the range specified by the recommended operating conditions. The characteristic values are guaranteed only under the conditions of each item specified by the electrical characteristics.

6. Inrush Current

When power is first supplied to the IC, it is possible that the internal logic may be unstable and inrush current may flow instantaneously due to the internal powering sequence and delays, especially if the IC has more than one power supply. Therefore, give special consideration to power coupling capacitance, power wiring, width of ground wiring, and routing of connections.

7. Testing on Application Boards

When testing the IC on an application board, connecting a capacitor directly to a low-impedance output pin may subject the IC to stress. Always discharge capacitors completely after each process or step. The IC's power supply should always be turned off completely before connecting or removing it from the test setup during the inspection process. To prevent damage from static discharge, ground the IC during assembly and use similar precautions during transport and storage.

8. Inter-pin Short and Mounting Errors

Ensure that the direction and position are correct when mounting the IC on the PCB. Incorrect mounting may result in damaging the IC. Avoid nearby pins being shorted to each other especially to ground, power supply and output pin. Inter-pin shorts could be due to many reasons such as metal particles, water droplets (in very humid environment) and unintentional solder bridge deposited in between pins during assembly to name a few.

9. Unused Input Pins

Input pins of an IC are often connected to the gate of a MOS transistor. The gate has extremely high impedance and extremely low capacitance. If left unconnected, the electric field from the outside can easily charge it. The small charge acquired in this way is enough to produce a significant effect on the conduction through the transistor and cause unexpected operation of the IC. So unless otherwise specified, unused input pins should be connected to the power supply or ground line.

10. Regarding the Input Pin of the IC

In the construction of this IC, P-N junctions are inevitably formed creating parasitic diodes or transistors. The operation of these parasitic elements can result in mutual interference among circuits, operational faults, or physical damage. Therefore, conditions which cause these parasitic elements to operate, such as applying a voltage to an input pin lower than the ground voltage should be avoided. Furthermore, do not apply a voltage to the input pins when no power supply voltage is applied to the IC. Even if the power supply voltage is applied, make sure that the input pins have voltages within the values specified in the electrical characteristics of this IC.

11. Ceramic Capacitor

When using a ceramic capacitor, determine a capacitance value considering the change of capacitance with temperature and the decrease in nominal capacitance due to DC bias and others.

Ordering Information

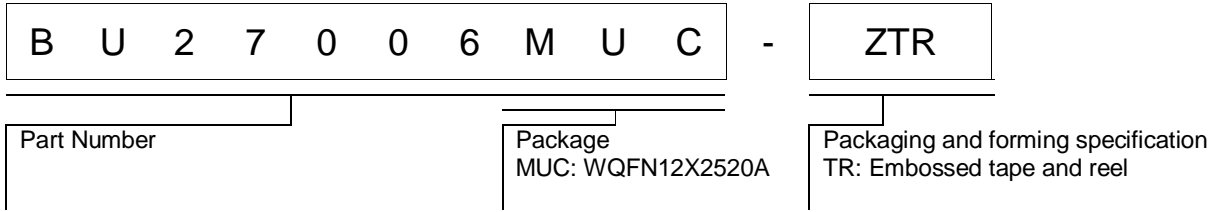

Marking Diagram

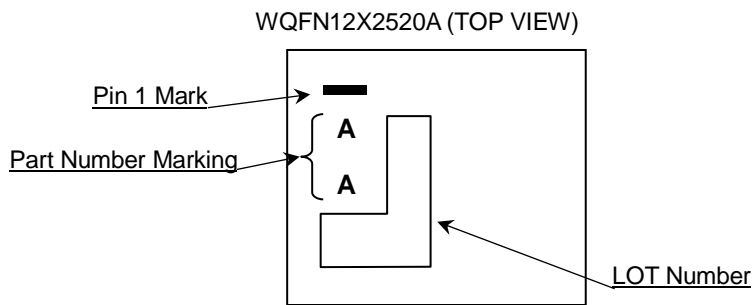

Revision History

Date	Revision	Changes
02. Apr. 2019	001	New Release

Notice

Precaution on using ROHM Products

- Our Products are designed and manufactured for application in ordinary electronic equipment (such as AV equipment, OA equipment, telecommunication equipment, home electronic appliances, amusement equipment, etc.). If you intend to use our Products in devices requiring extremely high reliability (such as medical equipment ^(Note 1), transport equipment, traffic equipment, aircraft/spacecraft, nuclear power controllers, fuel controllers, car equipment including car accessories, safety devices, etc.) and whose malfunction or failure may cause loss of human life, bodily injury or serious damage to property ("Specific Applications"), please consult with the ROHM sales representative in advance. Unless otherwise agreed in writing by ROHM in advance, ROHM shall not be in any way responsible or liable for any damages, expenses or losses incurred by you or third parties arising from the use of any ROHM's Products for Specific Applications.

(Note1) Medical Equipment Classification of the Specific Applications

JAPAN	USA	EU	CHINA
CLASS III	CLASS III	CLASS II b	CLASS III
CLASS IV		CLASS III	

- ROHM designs and manufactures its Products subject to strict quality control system. However, semiconductor products can fail or malfunction at a certain rate. Please be sure to implement, at your own responsibilities, adequate safety measures including but not limited to fail-safe design against the physical injury, damage to any property, which a failure or malfunction of our Products may cause. The following are examples of safety measures:
 - Installation of protection circuits or other protective devices to improve system safety
 - Installation of redundant circuits to reduce the impact of single or multiple circuit failure
- Our Products are designed and manufactured for use under standard conditions and not under any special or extraordinary environments or conditions, as exemplified below. Accordingly, ROHM shall not be in any way responsible or liable for any damages, expenses or losses arising from the use of any ROHM's Products under any special or extraordinary environments or conditions. If you intend to use our Products under any special or extraordinary environments or conditions (as exemplified below), your independent verification and confirmation of product performance, reliability, etc. prior to use, must be necessary:
 - Use of our Products in any types of liquid, including water, oils, chemicals, and organic solvents
 - Use of our Products outdoors or in places where the Products are exposed to direct sunlight or dust
 - Use of our Products in places where the Products are exposed to sea wind or corrosive gases, including Cl₂, H₂S, NH₃, SO₂, and NO₂
 - Use of our Products in places where the Products are exposed to static electricity or electromagnetic waves
 - Use of our Products in proximity to heat-producing components, plastic cords, or other flammable items
 - Sealing or coating our Products with resin or other coating materials
 - Use of our Products without cleaning residue of flux (Exclude cases where no-clean type fluxes is used. However, recommend sufficiently about the residue.) ; or Washing our Products by using water or water-soluble cleaning agents for cleaning residue after soldering
 - Use of the Products in places subject to dew condensation
- The Products are not subject to radiation-proof design.
- Please verify and confirm characteristics of the final or mounted products in using the Products.
- In particular, if a transient load (a large amount of load applied in a short period of time, such as pulse, is applied, confirmation of performance characteristics after on-board mounting is strongly recommended. Avoid applying power exceeding normal rated power; exceeding the power rating under steady-state loading condition may negatively affect product performance and reliability.
- De-rate Power Dissipation depending on ambient temperature. When used in sealed area, confirm that it is the use in the range that does not exceed the maximum junction temperature.
- Confirm that operation temperature is within the specified range described in the product specification.
- ROHM shall not be in any way responsible or liable for failure induced under deviant condition from what is defined in this document.

Precaution for Mounting / Circuit board design

- When a highly active halogenous (chlorine, bromine, etc.) flux is used, the residue of flux may negatively affect product performance and reliability.
- In principle, the reflow soldering method must be used on a surface-mount products, the flow soldering method must be used on a through hole mount products. If the flow soldering method is preferred on a surface-mount products, please consult with the ROHM representative in advance.

For details, please refer to ROHM Mounting specification

Precautions Regarding Application Examples and External Circuits

1. If change is made to the constant of an external circuit, please allow a sufficient margin considering variations of the characteristics of the Products and external components, including transient characteristics, as well as static characteristics.
2. You agree that application notes, reference designs, and associated data and information contained in this document are presented only as guidance for Products use. Therefore, in case you use such information, you are solely responsible for it and you must exercise your own independent verification and judgment in the use of such information contained in this document. ROHM shall not be in any way responsible or liable for any damages, expenses or losses incurred by you or third parties arising from the use of such information.

Precaution for Electrostatic

This Product is electrostatic sensitive product, which may be damaged due to electrostatic discharge. Please take proper caution in your manufacturing process and storage so that voltage exceeding the Products maximum rating will not be applied to Products. Please take special care under dry condition (e.g. Grounding of human body / equipment / solder iron, isolation from charged objects, setting of Ionizer, friction prevention and temperature / humidity control).

Precaution for Storage / Transportation

1. Product performance and soldered connections may deteriorate if the Products are stored in the places where:
 - [a] the Products are exposed to sea winds or corrosive gases, including Cl₂, H₂S, NH₃, SO₂, and NO₂
 - [b] the temperature or humidity exceeds those recommended by ROHM
 - [c] the Products are exposed to direct sunshine or condensation
 - [d] the Products are exposed to high Electrostatic
2. Even under ROHM recommended storage condition, solderability of products out of recommended storage time period may be degraded. It is strongly recommended to confirm solderability before using Products of which storage time is exceeding the recommended storage time period.
3. Store / transport cartons in the correct direction, which is indicated on a carton with a symbol. Otherwise bent leads may occur due to excessive stress applied when dropping of a carton.
4. Use Products within the specified time after opening a humidity barrier bag. Baking is required before using Products of which storage time is exceeding the recommended storage time period.

Precaution for Product Label

A two-dimensional barcode printed on ROHM Products label is for ROHM's internal use only.

Precaution for Disposition

When disposing Products please dispose them properly using an authorized industry waste company.

Precaution for Foreign Exchange and Foreign Trade act

Since concerned goods might be fallen under listed items of export control prescribed by Foreign exchange and Foreign trade act, please consult with ROHM in case of export.

Precaution Regarding Intellectual Property Rights

1. All information and data including but not limited to application example contained in this document is for reference only. ROHM does not warrant that foregoing information or data will not infringe any intellectual property rights or any other rights of any third party regarding such information or data.
2. ROHM shall not have any obligations where the claims, actions or demands arising from the combination of the Products with other articles such as components, circuits, systems or external equipment (including software).
3. No license, expressly or implied, is granted hereby under any intellectual property rights or other rights of ROHM or any third parties with respect to the Products or the information contained in this document. Provided, however, that ROHM will not assert its intellectual property rights or other rights against you or your customers to the extent necessary to manufacture or sell products containing the Products, subject to the terms and conditions herein.

Other Precaution



1. This document may not be reprinted or reproduced, in whole or in part, without prior written consent of ROHM.
2. The Products may not be disassembled, converted, modified, reproduced or otherwise changed without prior written consent of ROHM.
3. In no event shall you use in any way whatsoever the Products and the related technical information contained in the Products or this document for any military purposes, including but not limited to, the development of mass-destruction weapons.
4. The proper names of companies or products described in this document are trademarks or registered trademarks of ROHM, its affiliated companies or third parties.

General Precaution







1. Before you use our Products, you are requested to carefully read this document and fully understand its contents. ROHM shall not be in any way responsible or liable for failure, malfunction or accident arising from the use of any ROHM's Products against warning, caution or note contained in this document.
2. All information contained in this document is current as of the issuing date and subject to change without any prior notice. Before purchasing or using ROHM's Products, please confirm the latest information with a ROHM sales representative.
3. The information contained in this document is provided on an "as is" basis and ROHM does not warrant that all information contained in this document is accurate and/or error-free. ROHM shall not be in any way responsible or liable for any damages, expenses or losses incurred by you or third parties resulting from inaccuracy or errors of or concerning such information.

Looking for pricing, stock, or lifecycle information?

Click below to explore more details on WIN SOURCE:

-  [View BU27006MUC-ZTR on WIN SOURCE](#)
-  [Rohm Semiconductor](#) Information

Optimize Your Supply Chain with WIN SOURCE Solutions

-  Global Sourcing Solution
-  Obsolete Management
-  Cost Control Management
-  Shortage Management
-  Alternative Solution
-  Excess Inventory Management