



**THE DATASHEET OF
S32G399AACK1VUCT**



S32G3

S32G3 Data Sheet

Rev. 2 — 02/2023

Data Sheet: Technical Data

- This document provides electrical specifications for S32G3.
- For functional characteristics and the programming model, see S32G3 Reference Manual.



Contents

1	Introduction.....	4			
1.1	Overview.....	4	16.3.5	LPSPI.....	71
1.2	Applications.....	4	16.3.6	CAN.....	74
2	Block diagram.....	5	16.4	FlexRay.....	74
3	Feature comparison.....	5	16.4.1	FlexRay - RxD.....	74
4	Ordering information.....	8	16.4.2	FlexRay - TxD.....	75
5	Electrostatic Discharge (ESD) Characteristics... 	9	16.4.3	FlexRay - TxEN.....	76
6	Absolute Max Ratings.....	9	16.9	PCIe.....	77
7	Operating conditions.....	13	16.6	GMAC and PFE.....	81
7.1	Operating Conditions.....	13	16.6.1	GMAC and PFE Management Interface.....	81
7.2	Clock frequency ranges.....	19	16.6.2	GMAC and PFE MII.....	82
8	Thermal Characteristics.....	22	16.6.3	GMAC MII 50MHz.....	83
9	DC electricals.....	22	16.6.4	GMAC and PFE RMII.....	84
9.1	Total power specifications for 0.8V and 1.8V Analog Domains.....	22	16.6.5	GMAC and PFE RGMII.....	85
9.2	Static power specifications for I/O Domains.	24	16.6.6	GMAC and PFE SGMII.....	87
9.3	Device Power and Operating Current Specifications.....	25	16.12	USB-ULPI.....	88
10	Power sequencing.....	29	16.8	Memory interfaces.....	89
10.1	Power-up.....	29	16.8.1	QuadSPI.....	89
10.2	Power-down.....	30	16.8.2	QuadSPI Quad 1.8V DDR 66MHz.....	89
11	Electromagnetic compatibility (EMC).....	30	16.8.3	QuadSPI Octal 1.8V SDR 133MHz.....	90
12	GPIO Pads.....	30	16.8.4	QuadSPI Octal 1.8V DDR 100MHz.....	90
13	Aurora specifications.....	40	16.8.5	QuadSPI Octal 1.8V DDR 133MHz.....	91
13.1	Aurora Pads.....	40	16.8.6	QuadSPI Octal 1.8V SDR 100MHz.....	92
13.2	Aurora Port Timing.....	43	16.8.7	QuadSPI Quad 1.8V SDR 133MHz.....	93
13.3	Aurora PLL.....	44	16.8.8	QuadSPI Quad 3.3V DDR 66MHz.....	93
14	Power Management Controller (PMC).....	46	16.8.9	QuadSPI Quad 3.3V SDR 104MHz.....	94
14.1	PMC Bandgap.....	46	16.8.10	QuadSPI Octal 1.8V DDR 166MHz.....	95
15	Reset.....	46	16.8.11	QuadSPI Octal 1.8V DDR 200MHz.....	95
15.1	Reset Duration.....	46	16.8.12	QuadSPI configurations.....	96
15.2	Reset and Standby related pad electrical characteristics.....	50	16.8.13	QuadSPI interfaces.....	97
15.3	PMIC Standby Mode Entry / Exit Protocol....	52	16.8.14	QuadSPI timing diagrams.....	98
16	Peripheral specifications.....	54	16.9	DDR.....	99
16.1	Analog Modules.....	54	16.9.1	DDR.....	99
16.1.1	SAR ADC.....	54	16.9.2	DDR Common DC Input.....	99
16.1.2	Temperature Monitoring Unit (TMU).....	56	16.9.3	DDR Common DC Output.....	100
16.1.3	Glitch Filter.....	57	16.9.4	DDR3L DC Input.....	101
16.1.4	IRQ.....	57	16.9.5	DDR3L Output Timing.....	101
16.2	Clock and PLL Interfaces.....	58	16.9.6	LPDDR4 DC Input timing.....	102
16.2.1	DFS.....	58	16.9.7	LPDDR4 Output Timing.....	102
16.2.2	FIRC.....	59	16.10	uSDHC.....	102
16.2.3	SIRC.....	59	16.10.1	uSDHC SD3.0/eMMC5.1 DDR.....	102
16.2.4	FXOSC.....	59	16.10.2	uSDHC SD3.0/SDIO3.0/eMMC5.1 SDR.....	104
16.2.5	PLL.....	61	16.10.3	uSDHC SDR-100MHz.....	105
16.3	Communication modules.....	63	16.10.4	uSDHC SDR-HS200.....	106
16.3.1	SPI.....	63	16.10.5	uSDHC DDR-HS400.....	107
16.3.2	I2C.....	68	16.11	Debug modules.....	108
16.3.4	LIN.....	71	16.11.1	JTAG Boundary Scan.....	108
			16.11.2	JTAG Debug Interface Timing.....	111
			16.11.3	SWD electrical specifications.....	112
			17	Pinouts.....	114
			18	Packaging.....	114

19 **Revision history**..... 120

Legal information..... 128

1 Introduction

1.1 Overview

S32G3 is a family of high-performance vehicle network processors that combine controller area network (CAN), local interconnect network (LIN), and FlexRay networking with high data rate Ethernet networking. It also combines a functional safe-core infrastructure with MPU cores and includes high-level security features. The S32G3 chips are pin-for-pin compatible with S32G2 chips, providing over 2x performance and over 2x system RAM.

Table 1. S32G3 family key enhancements

Feature	Enhancements
Compute performance	Up to 2.6 x increase in applications performance (doubling Cortex-A53 cores @ 1.3x frequency)
Real-time memory	Increase SRAM from 6 MB / 8 MB to 15 MB / 20 MB
Real-time performance	Additional pair of Cortex-M7 lockstep cores
Ethernet interface bandwidth	Increased speed from 1 Gbps to 2.5 Gbps on two SGMII interfaces
Ethernet packet routing	Performance target increase from 2 Gbps@64B to 3 Gbps@64B

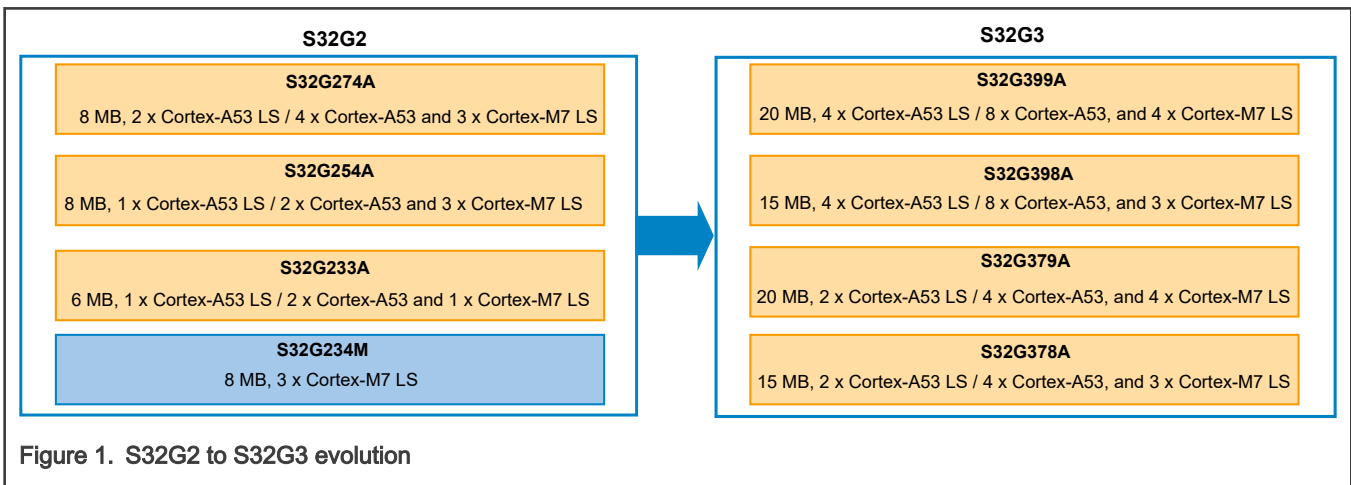

Figure 1. S32G2 to S32G3 evolution

S32G3 family includes the following variants:

- S32G399A
- S32G398A
- S32G379A
- S32G378A

This document primarily represents the features offered by the superset S32G399A. To compare the features of the S32G3 family variants, see [Feature comparison](#).

1.2 Applications

Combining ASIL D safety, hardware security, high-performance real-time and application processing and network acceleration, this chip targets applications that includes:

- Service-oriented gateways and domain controllers
- Safety processor for ADAS and autonomous driving
- High-performance central compute nodes

- FOTA masters controlling secure software image downloads and their distribution to the ECUs in the network
- Security services and key management
- Smart antennas

2 Block diagram

The following is the block diagram for S32G399A, the superset chip in the S32G3 family.

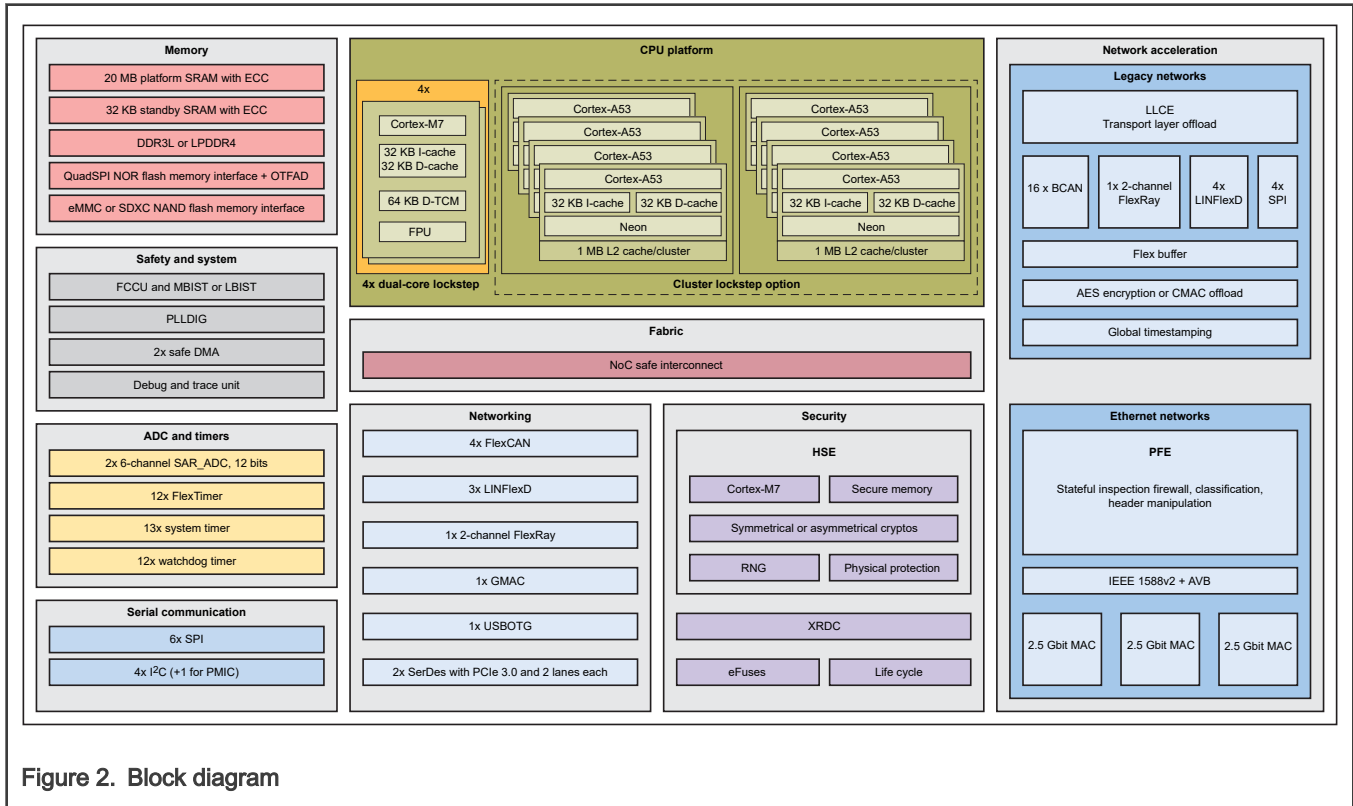

Figure 2. Block diagram

3 Feature comparison

This table compares the features of the chips in the S32G3 family.

Table 2. S32G3 feature list and supported functionality

Feature	S32G399A	S32G398A	S32G379A	S32G378A
Compute and bus modules				
Applications CPUs	4 x Cortex-A53 LS (8 x Cortex-A53)	4 x Cortex-A53 LS (8 x Cortex-A53)	2 x Cortex-A53 LS (4 x Cortex-A53) ¹	2 x Cortex-A53 LS (4 x Cortex-A53) ¹
Real-time CPUs	4 x Cortex-M7 LS	3 x Cortex-M7 LS ²	4 x Cortex-M7 LS	3 x Cortex-M7 LS ²
Cortex-A53				
L1 cache	32 KB I-cache and 32 KB D-cache per Cortex-A53 core			
L2 cache	1 MB per cluster			

Table continues on the next page...

Table 2. S32G3 feature list and supported functionality (continued)

Feature	S32G399A	S32G398A	S32G379A	S32G378A
Cache coherency interconnect	Supported			
Interrupt controller	GIC-500			
Maximum frequency	Up to 1.3 GHz			
Functional safety	Configurable ASIL D lockstep clusters and two ASIL B independent clusters			
Cortex-M7				
L1 cache	32 KB I-cache and 32 KB D-cache per Cortex-M7			
Cache coherency interconnect	Not supported			
Interrupt controller	4 x NVIC			
Maximum frequency	400 MHz			
Functional safety	Dual-core lockstep			
DTCM	64 KB per Cortex-M7			
System modules				
DMA	2x safe eDMA (supporting lockstep) with 32 channels per eDMA			
DMAMUX	128 inputs per DMA			
Debug: Run control	Arm CoreSight JTAG (IEEE 1149.1)			
Debug: Trace	4-lane Aurora			
SWT instances	12			
STM instances	13			
Memory modules				
Internal RAM	20 MB	15 MB ³	20 MB	15 MB ³
RAM ports	16 (four groups of four ports each), and ports in each group are interleaved at 64 bytes			
DRAM	DDR3L and LPDDR4 – up to 4 GB			
DRAM PHY	x32			
QuadSPI instances	1			
uSDHC instances	1			
Fuses	8 KB bank			
Standby SRAM with ECC	32 KB			
Security modules				
Security subsystem	HSE_H			

Table continues on the next page...

Table 2. S32G3 feature list and supported functionality (continued)

Feature	S32G399A	S32G398A	S32G379A	S32G378A
Resource isolation	XRDC supporting 16 domains			
Arm TrustZone	Supported			
Life cycle	Supported			
Secure debug	Supported			
Communication interface modules				
Communication acceleration	LLCE			
CAN with flexible data rate	16 in LLCE and 4 outside LLCE			
FlexRay 2.1 (dual-channel) instances	1 in LLCE and 1 outside LLCE			
LINFlexD instances	4 in LLCE and 3 outside LLCE			
Ethernet acceleration	PFE			
Ethernet MAC	3 in PFE and 1 outside PFE			
Ethernet interface	MII, RMII, RGMII, SGMII			
PCIe controller	2x Gen3 controllers (X1, X2 modes)			
SerDes subsystem	Four lanes (configurable PCIe and SGMII)			
USBOTG instances	1, supporting USB 2.0 and a ULPI interface			
I ² C instances	4 + 1 for power management integrated circuits (PMIC)			
SPI instances	4 (in LLCE, can be enabled with firmware) and 6 outside LLCE			
CRC instances	1			
Generic modules				
PIT instances	2			
SAR_ADC instances	12-bit 2 x 6 channels			
FTM instances	2 x 6 channels			
CTU instances	1			
SEMA42 instances	1			
Clocking, power, and reset modules				
FIRC frequency	48 MHz			
SIRC frequency	32 KHz			
FXOSC frequency	20-40 MHz			
PLLDIG instances	5			
Low-power mode	Supported			

Table continues on the next page...

Table 2. S32G3 feature list and supported functionality (continued)

Feature	S32G399A	S32G398A	S32G379A	S32G378A
RTC	1 with API function			
Wake-up	24 wake-up sources			
Miscellaneous				
Package specifications and dimensions	525 flip-chip plastic ball-grid array; 19 mm x 19mm x 0.8 mm			

1. Cortex-A53_2 and Cortex-A53_3 have been defeatured in cluster 0 and cluster 1.
2. Cortex-M7_2 has been defeatured. See the System RAM Controller chapter of the S32G3 Reference Manual for details.
3. SRAM (12, 13, 14, 15) i.e., the highest address range (0x34F0_0000–0x353F_FFFF) associated to Cortex-M7_2 have been defeatured. See the System RAM Controller chapter of the S32G3 Reference Manual for details on internal RAM support across the family.

4 Ordering information

S32G3 Part Numbering*

Production Part Number	S32	1-3	Product brand and Status	1st 2nd, 3rd Characters Product brand and status P32 = Prototype chip S32 = Qualified device	9th Character Chip configuration A = Standard chip S = Premium security chip
	G	4	Product line		
	3	5	Family	4th Character Product line G = Gateway	10th Character Arm core speeds A = 400 MHz (Cortex-M7), 1000 MHz (Cortex-A53) B = 400 MHz (Cortex-M7), 1100 MHz (Cortex-A53) C = 400 MHz (Cortex-M7), 1300 MHz (Cortex-A53)
	9	6	MPU performance identifier		
	9	7	MCU performance identifier and system RAM size	5th Character Family 3 = S32G3 family	11th and 12th Characters Fab and mask revision K = TSMC fab x = Mask revision (0 = first mask revision)
	A	8	Product type		
	S	9	Chip configuration	6th Character MPU performance identifier 7 – 4x Cortex-A53 9 – 8x Cortex-A53	13th Character Temperature (T _A) range C = -40 °C to 85 °C V = -40 °C to 105 °C
	C	10	Arm core speeds		
	K0	11-12	Fab and mask revision	7th Character MCU performance identifier and system RAM size 8 = 3x Cortex-M7 and 15 MB SRAM 9 = 4x Cortex-M7 and 20 MB SRAM	14th and 15th Characters Package code UC = 525 FC-PBGA, 19x19mm, 0.8mm pitch
	V	13	Temperature (T _A) range		
	UC	14-15	Package code	8th Character Product type A = MCU + MPU	16th Character Shipping method T = Tray R = Reel
	R	16	Shipping method		

	S32G378A	S32G379A	S32G398A	S32G399A
ARM Cortex-M7 Cores	3	4	3	4
ARM Cortex-A53 Cores	4	4	8	8
System RAM Size	15 MB	20 MB	15 MB	20 MB

*Contact NXP sales representative for part numbers

Figure 3. Ordering information

5 Electrostatic Discharge (ESD) Characteristics

The following table gives the ESD ratings and test conditions for the device.

Table 3. Electrostatic Discharge (ESD) Characteristics

Symbol	Description	Min	Typ	Max	Unit	Condition	Spec Number
—	ESD Human Body Model (HBM) ^{1, 2, 3}	—	—	2000	V	All pins	—
—	ESD Charged Device Model (CDM) ^{1, 3, 4}	—	—	250	V	All pins	—

1. Device failure is defined as: "If after exposure to ESD pulses, the device does not meet the device specification requirements."
2. This parameter is tested in conformity with AEC-Q100-002
3. All ESD testing conforms with AEC-Q100 Stress Test Qualification for Automotive Grade Integrated Circuits.
4. This parameter is tested in conformity with AEC-Q100-011.

6 Absolute Max Ratings

This table defines the absolute maximum ratings for the device in terms of reliability characteristics. Absolute maximum rating specifications are stress ratings only, and functional operation is not guaranteed under these conditions. Functional operating conditions are given in the Operating Conditions section of this document.

NOTE

All specifications associated with VIN are measured at the SoC pin.

Table 4. Absolute Max Ratings

Symbol	Description	Min	Typ	Max	Unit	Condition	Spec Number
VDD	Core voltage Supply ^{1, 2}	-0.3	—	0.96	V	—	—
VSS	Ground Supply ¹	-0.3	—	0.3	V	—	—
VDD_STBY	Standby domain supply voltage ^{1, 2}	-0.3	—	0.96	V	—	—
VDD_LV_PLL_AUR	Aurora PLL digital voltage supply ^{1, 2}	-0.3	—	0.96	V	—	—
VDD_LV_PLL_DDR0	DDR0 PLL digital voltage supply ^{1, 2}	-0.3	—	0.96	V	—	—
VDD_VP_PCIE _n	PCIE0/1 core voltage supply (n=0, 1) ^{1, 2}	-0.3	—	0.96	V	—	—
VDD_FIRC	FIRC high voltage supply ^{1, 3}	-0.3	—	2.16	V	—	—
VDD_EFUSE	EFUSE high voltage supply ^{1, 3}	-0.3	—	2.16	V	—	—

Table continues on the next page...

Table 4. Absolute Max Ratings (continued)

Symbol	Description	Min	Typ	Max	Unit	Condition	Spec Number
VDD_IO_x	GPIO 3.3V supply ^{1, 4}	-0.3	—	4	V	—	—
VDD_IO_A	GPIO A 3.3V supply ^{1, 4}	-0.3	—	4	V	—	—
VDD_IO_B	GPIO B 3.3V supply ^{1, 4}	-0.3	—	4	V	—	—
VDD_IO_GMAC0	GMAC0 I/O voltage supply ^{1, 4}	-0.3	—	4	V	—	—
VDD_IO_GMAC1	GMAC1 I/O voltage supply ^{1, 4}	-0.3	—	4	V	—	—
VDD_IO_QSPI	QSPI A I/O voltage supply ^{1, 3}	-0.3	—	2.16	V	—	—
VDD_IO_SDHC	uSDHC / QSPI B I/O voltage supply ^{1, 4}	-0.3	—	4	V	—	—
VDD_IO_CLKOUT	CLKOUT 1.8V I/O supply ^{1, 3}	-0.3	—	2.16	V	—	—
VDD_IO_AUR	Aurora 1.8V I/O supply ^{1, 3}	-0.3	—	2.16	V	—	—
VDD_IO_DDR0	DDR0 I/O voltage supply ¹	-0.3	—	2.16	V	—	—
VDD_IO_USB	USB I/O voltage supply ^{1, 4}	-0.3	—	4	V	—	—
VDD_IO_STBY	Standby domain I/O voltage supply ^{1, 4}	-0.3	—	4	V	—	—
VDD_VREF	Supply detector high voltage supply ^{1, 3}	-0.3	—	2.16	V	—	—
VDD_ADC	ADC voltage supply ^{1, 3}	-0.3	—	2.16	V	Reference to VSS_ ADC	—
VSS_ADC	ADC ground supply ¹	-0.3	—	0.3	V	Reference to VSS	—
VDD_HV_PLL	PLL high voltage supply ^{1, 3}	-0.3	—	2.16	V	—	—
VDD_HV_PLL_AUR	Aurora PLL high voltage supply ^{1, 3}	-0.3	—	2.16	V	—	—
VDD_HV_PLL_DDR0	DDR PLL voltage supply ^{1, 3}	-0.3	—	2.16	V	—	—
VDD_DDR0	DDR0 high voltage supply ^{1, 3}	-0.3	—	2.16	V	DDR PHY PLL	—

Table continues on the next page...

Table 4. Absolute Max Ratings (continued)

Symbol	Description	Min	Typ	Max	Unit	Condition	Spec Number
VDD_FXOSC	FXOSC high voltage supply ^{1, 3}	-0.3	—	2.16	V	Reference to VSS_FXOSC	—
VSS_FXOSC	FXOSC ground supply ¹	-0.3	—	0.3	V	Reference to VSS	—
VEXTAL	FXOSC EXTAL input voltage range ^{1, 3, 5}	-0.3	—	2.16	V	—	—
VXTAL	FXOSC XTAL input voltage range ^{1, 3, 5}	-0.3	—	2.16	V	—	—
VDD_IO_PCIE _n	PCIe0/1 high voltage supply (n=0, 1) ^{1, 3}	-0.3	—	2.16	V	—	—
VDD_TMU	Thermal Monitoring Unit (TMU) high voltage supply ^{1, 3}	-0.3	—	2.16	V	—	—
VREFH_ADC	ADC reference high voltage ^{1, 3}	-0.3	—	2.16	V	Reference to VREFL_ADC	—
VREFL_ADC	ADC reference low voltage ¹	-0.3	—	0.3	V	Reference to VSS	—
VAD_INPUT	ADC input voltage range ^{1, 6, 7}	VSS_AD C -0.6	—	VDD_AD C +0.5	V	—	—
VIN	GPIO input voltage range ^{1, 8, 9, 10}	VSS - 0.3	—	VDD_IO_* + 0.3	V	—	—
IINJ_D	Maximum DC current injection digital I/O pin ^{1, 11}	-3	—	3	mA	—	—
IINJ_A	Maximum DC current injection analog input pin ^{1, 6, 12}	-1	—	1	mA	—	—
IINJ_LVDS	Max LVDS RX or TX pin injection current ^{1, 13}	0	—	100	uA	—	—
IINJ_LVDS	Max LVDS RX or TX pin injection current ¹	0	—	100	uA	—	—
IMAXSEG	Maximum RMS current per GPIO supply domain (VDD_IO_*) ¹	—	—	140	mA	—	—
TSTG	Storage temperature range ¹	-55	—	150	C	—	—

Table continues on the next page...

Table 4. Absolute Max Ratings (continued)

Symbol	Description	Min	Typ	Max	Unit	Condition	Spec Number
TSDR	Maximum solder temperature ^{1, 14}	—	—	260	C	Pb free	—
MSL	Moisture Sensitivity Level ^{1, 15}	—	—	3	—	—	—
V_OS_US_10	Voltage at 10 % of t _{SIGNAL} ¹⁶	-0.4	—	3.7	V	3.3V, See "SoC-pin overshoot/undershoot voltage for each GPIO pad type" figure below	—
V_OS_US_7p5	Voltage at 7.50 % of t _{SIGNAL} ¹⁶	-0.5	—	3.8	V	3.3V, See "SoC-pin overshoot/undershoot voltage for each GPIO pad type" figure below	—
V_OS_US_2p5	Voltage at 2.50 % of t _{SIGNAL} ¹⁶	-0.6	—	3.9	V	3.3V, See "SoC-pin overshoot/undershoot voltage for each GPIO pad type" figure below	—
V_OS_US_1p6	Voltage at 1.60 % of t _{SIGNAL} ¹⁶	-0.7	—	4	V	3.3V, See "SoC-pin overshoot/undershoot voltage for each GPIO pad type" figure below	—
V_OS_US_10	Voltage at 10 % of t _{SIGNAL} ¹⁷	-0.7	—	2.31	V	1.8V, See "SoC-pin overshoot/undershoot voltage for each GPIO pad type" figure below	—

1. Absolute maximum ratings are stress ratings only, and functional operation at the maxima is not guaranteed. Stress beyond the listed maxima may affect device reliability or cause permanent damage to the device. See the operating conditions table for functional specifications.
2. Allowed 0.88V – 0.96V for 60 seconds cumulative over lifetime with no operating restrictions, 2.0 hours cumulative over lifetime with device in reset, at maximum T_j = 125 °C
3. Allowed 1.92V - 2.16V for 60 seconds cumulative over lifetime with no operating restrictions, 2.6 hours cumulative over lifetime with device in reset, at maximum T_j = 125 °C
4. Allowed 3.52V - 4.0V for 60 seconds cumulative over lifetime with no operating restrictions, 2.6 hours cumulative over lifetime with device in reset, at maximum T_j = 125 °C
5. VEXTAL/ VXTAL (min) is for powered condition. VEXTAL/VXTAL (min) can be lower in unpowered condition.
6. Allowed for a cumulative duration of 50 hours operation over the lifetime of the device at maximum T_j, with VDD_ADC <= 1.92V, VSS_ADC = 0V. Allowed for unlimited duration if the device is unpowered.
7. The maximum input voltage on an I/O pin tracks with the associated I/O supply maximum. For the injection current condition on a pin, the voltage equals the supply plus the voltage drop across the internal ESD diode from I/O pin to supply.
8. Absolute maximum DC VIN levels for a powered device are 3.82V and 2.22V, for 3.3V and 1.8V domains, respectively. For powered devices when VIN ≥ VDD_IO*, VIN must simultaneously follow the constraint that VIN-VDD_IO* ≤ 0.3V for the DC case. For unpowered devices, the allowed VIN max level is +0.9V. Unpowered devices must simultaneously follow IINJ_D unpowered current injection constraints.
9. Absolute minimum DC VIN level for a powered device is -0.3V. For unpowered devices, the allowed VIN min level is -0.9V. Unpowered devices must simultaneously follow IINJ_D unpowered current injection constraints.
10. DC case limit. Overshoot/Undershoot beyond this range is allowed, but only for the limited durations as constrained by temporal percentages of t_{SIGNAL}.
11. IINJ_D specifications are per pin for an unpowered condition of the associated supply. The maximum simultaneous injection per supply is 30mA.

- 12. Non-disturb of ADC channels during current injection cannot be guaranteed. The degradation in channel performance cannot be specified due to the dynamic operation of the ADC input mux and potential for varying charge distribution. For the max +/-1mA DC injection quoted here, VAD_INPUT would be +0.5/-0.6V relative to VREFH_ADC/VREFL_ADC at max Tj. ADC Output of the channel into which injection occurs will saturate depending on the direction of injection and for the channels not subject to current injection Offset error would be -12 LSB to 6 LSB and TUE would be -12 LSB to 8 LSB.
- 13. Applies exclusively to ZipWire and does not apply to Aurora. Allowed for a cumulative of 14 hours over the life of the part. The voltage on the RX or TX pin must not exceed 2.16 V at any time during the power-cycling or normal operation.
- 14. Solder profile per IPC/JEDEC J-STD-020D.
- 15. Moisture sensitivity per JEDEC test method A112.
- 16. For AC Signals in a 3.3V supply domain, if VDD_IO ≤ 3.3V, max VIN overshoot is limited to VDD_IO+20%. If VDD_IO > 3.3V, then max VIN overshoot is limited to 4V.
- 17. For AC Signals in a 1.8V supply domain, max VIN overshoot is limited to VDD_IO+20% for 10% of tSIGNAL.

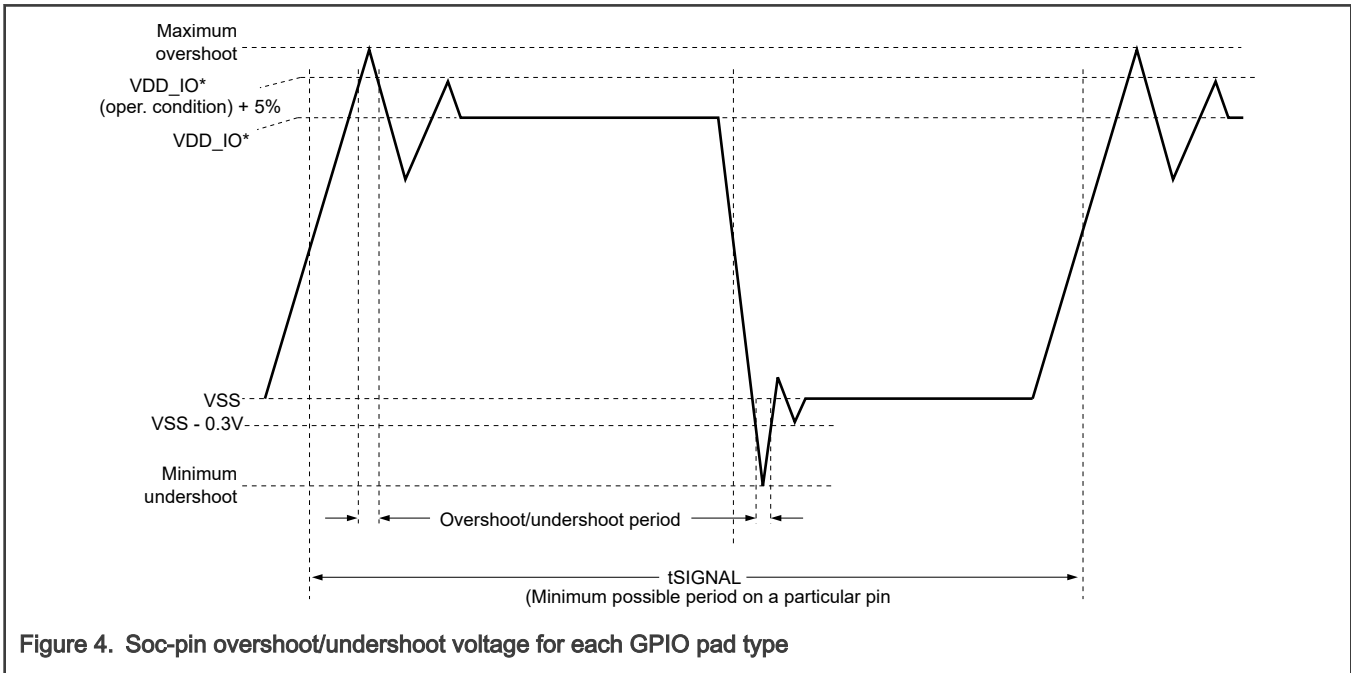

7 Operating conditions

7.1 Operating Conditions

The following table describes the functional operating conditions for the device, and for which all specifications in this datasheet are valid, except where explicitly noted. Device behavior is not guaranteed for operation outside of the conditions in this table.

NOTE

ΔVDD^* specifications are applicable to the supplies mentioned in the condition column when the device is not in standby mode. VDD_IO_B, VDD_IO_QSPI and VDD_DDR0 may stay powered in standby mode as applicable to the group.

NOTE

All specifications associated with VIN are measured at the SoC pin.

Table 5. Operating Conditions

Symbol	Description	Min	Typ	Max	Unit	Condition	Spec Number
fSYS_A53	Cortex-A53 core operating frequency ^{1, 2}	—	—	1311	MHz	—	—
fSYS_CM7	Cortex-M7 core operating frequency ^{1, 2}	—	—	400	MHz	—	—
fSYS_PFE_PE	PFE PE operating frequency ^{1, 2}	—	—	600	MHz	—	—
Tj	Junction Temperature Range ^{1, 3, 4}	-40	—	125	C	—	—
Ta	Ambient Temperature Range ^{1, 4}	-40	—	105	C	—	—
VDD	Core voltage Supply ¹	0.75	0.8	0.87	V	—	—
VSS	Ground Supply ¹	—	0	—	V	—	—
VDD_STBY	Standby domain supply voltage ^{1, 5}	0.75	0.8	0.87	V	—	—
VDD_LV_PLL_AUR	Aurora PLL digital voltage supply ¹	0.75	0.8	0.87	V	—	—
VDD_LV_PLL_DDR0	DDR0 PLL digital voltage supply ¹	0.75	0.8	0.87	V	—	—
VDD_VP_PCIE0	PCIE0/1 core voltage supply ^{1, 6}	0.75	0.8	0.87	V	—	—
VDD_IO_A	GPIO A 3.3V supply ¹	3.08	3.3	3.52	V	—	—
VDD_IO_B	GPIO B 3.3V supply ^{1, 7}	3.08	3.3	3.52	V	—	—
VDD_IO_GMAC0	GMAC0 I/O voltage supply ¹	1.68	1.8	1.92	V	1.8V	—
VDD_IO_GMAC0	GMAC0 I/O voltage supply ¹	3.08	3.3	3.52	V	3.3V	—
VDD_IO_GMAC1	GMAC1 I/O voltage supply ¹	1.68	1.8	1.92	V	1.8V	—
VDD_IO_GMAC1	GMAC1 I/O voltage supply ¹	3.08	3.3	3.52	V	3.3V	—
VDD_IO_QSPI	QuadSPI A I/O voltage supply ^{1, 8}	1.68	1.8	1.92	V	1.8V	—

Table continues on the next page...

Table 5. Operating Conditions (continued)

Symbol	Description	Min	Typ	Max	Unit	Condition	Spec Number
VDD_IO_SDHC	uSDHC / QSPI B I/O voltage supply ¹	1.68	1.8	1.92	V	1.8V	—
VDD_IO_SDHC	uSDHC I/O voltage supply ¹	3.08	3.3	3.52	V	3.3V	—
VDD_IO_CLKOUT	CLKOUT 1.8V I/O supply ¹	1.68	1.8	1.92	V	—	—
VDD_IO_AUR	Aurora 1.8V I/O supply ¹	1.68	1.8	1.92	V	Aurora LVDS Tx + ref clock	—
VDD_IO_STBY	Standby domain I/O voltage supply ^{1,7}	3.08	3.3	3.52	V	—	—
VDD_IO_USB	USB I/O voltage supply ¹	1.68	1.8	1.92	V	1.8V	—
VDD_IO_USB	USB I/O voltage supply ¹	3.08	3.3	3.52	V	3.3V	—
VDD_IO_DDR0	DDR3L I/O voltage supply ¹	1.283	1.35	1.45	V	—	—
VDD_IO_DDR0	LPDDR4 I/O voltage supply ¹	1.06	1.1	1.17	V	—	—
δVDD_IO_DDR0	DDR3L I/O supply ripple voltage ¹	-5	—	5	%	—	—
δVDD_IO_DDR0	LPDDR4 I/O supply ripple voltage ¹	-2.5	—	2.5	%	—	—
VDD_DDR0	DDR0 high voltage supply ¹	1.68	1.8	1.92	V	—	—
VDD_FIRC	FIRC high voltage supply ¹	1.68	1.8	1.92	V	—	—
VDD_VREF	PMC high voltage supply ¹	1.68	1.8	1.92	V	—	—
VDD_EFUSE	EFUSE high voltage supply ^{1, 9, 10, 11}	1.68	1.8	1.92	V	—	—
VDD_ADC	ADC high voltage supply ¹	1.68	1.8	1.92	V	—	—
VDD_HV_PLL	PLL high voltage supply ¹	1.68	1.8	1.92	V	—	—
VDD_HV_PLL_AUR	Aurora PLL high voltage supply ¹	1.68	1.8	1.92	V	—	—
VDD_HV_PLL_DDR0	DDR PLL voltage supply ¹	1.68	1.8	1.92	V	—	—

Table continues on the next page...

Table 5. Operating Conditions (continued)

Symbol	Description	Min	Typ	Max	Unit	Condition	Spec Number
δ VDD_HV_PLL_DDR0	DDR PLL supply ripple voltage ¹	-2.5	—	2.5	%	—	—
VDD_FXOSC	FXOSC high voltage supply ¹	1.68	1.8	1.92	V	—	—
VDD_IO_PCIEn	PCIE0/1 high voltage supply ^{1, 6}	1.68	1.8	1.92	V	—	—
VDD_TMU	Thermal Monitoring Unit (TMU) high voltage supply ¹	1.68	1.8	1.92	V	—	—
VREFH_ADCn	ADC reference high voltage (n=0, 1) ¹	1.68	1.8	1.92	V	—	—
VIN_33	3.3V GPIO input voltage range ^{1, 12, 13, 14}	VSS - 0.3	—	VDD_IO_* + 0.3	V	—	—
VIN_18	1.8V GPIO input voltage range ^{1, 12, 13, 14}	VSS - 0.3	—	VDD_IO_* + 0.3	V	—	—
Δ VDD	0.8V supply voltage differential ^{1, 15}	-25	—	25	mV	Applies to all 0.8V supplies on the device.	—
Δ VDD_HV_18_IO	1.8V I/O supply voltage differential group ^{1, 15}	-25	—	25	mV	Applies to VDD_IO_QSPI, VDD_IO_SDHC, VDD_IO_GMAC0, VDD_IO_GMAC1, VDD_IO_USB	—
Δ VDD_HV_18_ANA	1.8V analog supply voltage differential group ^{1, 9, 10, 11, 15, 16}	-25	—	25	mV	Applies to VDD_IO_CLKOUT, VDD_IO_AUR, VDD_TMU, VREFH_ADC*, VDD_ADC, VDD_HV_PLL*, VDD_VREF, VDD_FXOSC, VDD_FIRC, VDD_EFUSE, VDD_DDR0, VDD_IO_PCIE0, VDD_IO_PCIE1	—
Δ VDD_HV_33_IO	3.3V I/O supply voltage differential group ^{1, 15}	-25	—	25	mV	VDD_IO_A, VDD_IO_B	—
Δ VSS_HV_18	1.8V supply ground voltage differential ^{1, 15}	-25	—	25	mV	Applies to VSS, VREFL_ADCn, VSS_ADC, VSS_FXOSC	—

Table continues on the next page...

Table 5. Operating Conditions (continued)

Symbol	Description	Min	Typ	Max	Unit	Condition	Spec Number
VRAMP_LV	LV supply voltage ramp-up rate ^{1, 17}	0.001	—	24	V / ms	Applies to 0.8V supplies	—
VRAMP_HV	HV supply voltage ramp-up rate ¹	0.001	—	24	V / ms	Applies to 1.8V supplies and DDR I/O supplies.	—
VRAMP_HV_33_IO	3.3V I/O supply voltage ramp-up rate ¹	0.001	—	50	V / ms	Applies to 3.3V I/O supplies.	—
TDISCHARGE_STDBY	Supply discharge time during Standby mode entry ¹	100	—	—	us	Applies to all switchable supplies during Standby mode entry	—
VAD_INPUT	ADC input voltage range ^{1, 18}	VSS_AD C - 0.35	—	VDD_AD C + 0.25	V	—	—
IINJ_D	GPIO Input DC Injection Current ^{1, 19}	-3	—	3	mA	Unpowered	—
IINJ_D	GPIO Input DC Injection Current ^{1, 20}	0	—	5	uA	Powered	—
IINJ_A	SAR ADC Input DC Injection Current ^{1, 21}	-20	—	20	uA	—	—
IMAXSEG	Maximum RMS current per GPIO supply domain ¹	—	—	120	mA	—	—

- The operating conditions in this table apply as required conditions for all other specifications in this document, unless explicitly noted as an exception in another section of this document.
- The stated maximum operating frequency must be observed when using the PLL with frequency modulation enabled. Center-spread modulation is supported in cases where the nominal operating frequency plus half the modulation depth is less than the stated maximum frequency.
- Lifetime operation at T_j max not guaranteed. Standard automotive temperature profile assumed for performance and reliability guarantees.
- The junction temperature (T_j) range specification cannot be violated. The ambient temperature shown in the table, is a rough indicative value, for a typical system. Customers must ensure there is an appropriate thermal solution in their system to keep T_j within the spec range
- The operating voltage range applies when the device is not in standby mode.
- Both PCIe supplies must ramp for the SerDes PHY to safely power up into its reset state. Until both supplies are ramped, the SerDes PHY will be in an undefined state.
- A minimum of 2.91V is supported on this supply when the device is in low-power standby mode if it is kept powered during this mode.
- The device supports QSPI interface to 3.3V memories on the QSPI B bank, which is multiplexed with uSDHC functions on the VDD_IO_SDHC supply. QSPI A signals on VDD_IO_QSPI are limited to 1.8V.
- The VDD_EFUSE supply must be maintained within specification during fuse programming. Failure to do this may result in improper functionality of the device after fuse programming.
- Refer to the Power Sequencing section for the relationship of VDD_EFUSE powering up/down relative to the core, high-voltage, and I/O supplies.
- VDD_EFUSE must be grounded when not actively programming the fuses. This supply is not required to be powered for fuse reads. See device hardware design guidelines document for more details.

12. For AC signals, allowed max $V_{IN} \leq VDD_IO^*$ for lifetime operation. If AC overshoot beyond VDD_IO^* occurs, then refer to the Abs Max duration constraints as a function of the amount of overshoot. For DC signals $\geq VDD_IO$, $V_{IN}-VDD_IO^* \leq 0.3V$ is allowed for lifetime operation.
13. The min DC V_{IN} level for a powered device is $-0.3V$. If AC undershoot below $-0.3V$ occurs, then refer to the Abs Max duration constraints as a function of the amount of undershoot.
14. DC case limit. Overshoot/Undershoot beyond this range is allowed, but only for the limited durations as constrained by temporal percentages of t SIGNAL.
15. The "voltage differential" refers to the difference between the lowest and highest voltages across all supplies within the supply group as defined under Condition column.
16. VREFH_ADCn allows a differential voltage of $\pm 100mV$.
17. On slow ramps, the RESET_B pin may be observed to be asserted multiple times during the supply ramping. In order to prevent these pulses from being propagated into the system, it is recommended that the PMIC drives RESET_B low during supply ramp or whenever POR_B is asserted.
18. The maximum input voltage on an I/O pin tracks with the associated I/O supply maximum. For the injection current condition on a pin, the voltage equals the supply plus the voltage drop across the internal ESD diode from I/O pin to supply.
19. IINJ_D specifications are per pin for an unpowered condition of the associated supply. The maximum simultaneous injection per supply is 30mA.
20. You must ensure that neither IINJ nor VIN specs are violated. Negligible DC injection currents are expected to flow during normal powered operation.
21. The SAR ADC electrical specifications are not guaranteed during any period when the operating injection current limit is violated. These specifications are at maximum T_j and $VREFH_ADC=1.8V$; the injected current will reduce with reduced T_j .

The device hardware design guidelines document summarizes mandatory board design rules in table "Decaps and Ferrite Bead requirement" and section "PDN (Power Delivery Network) Guidelines".

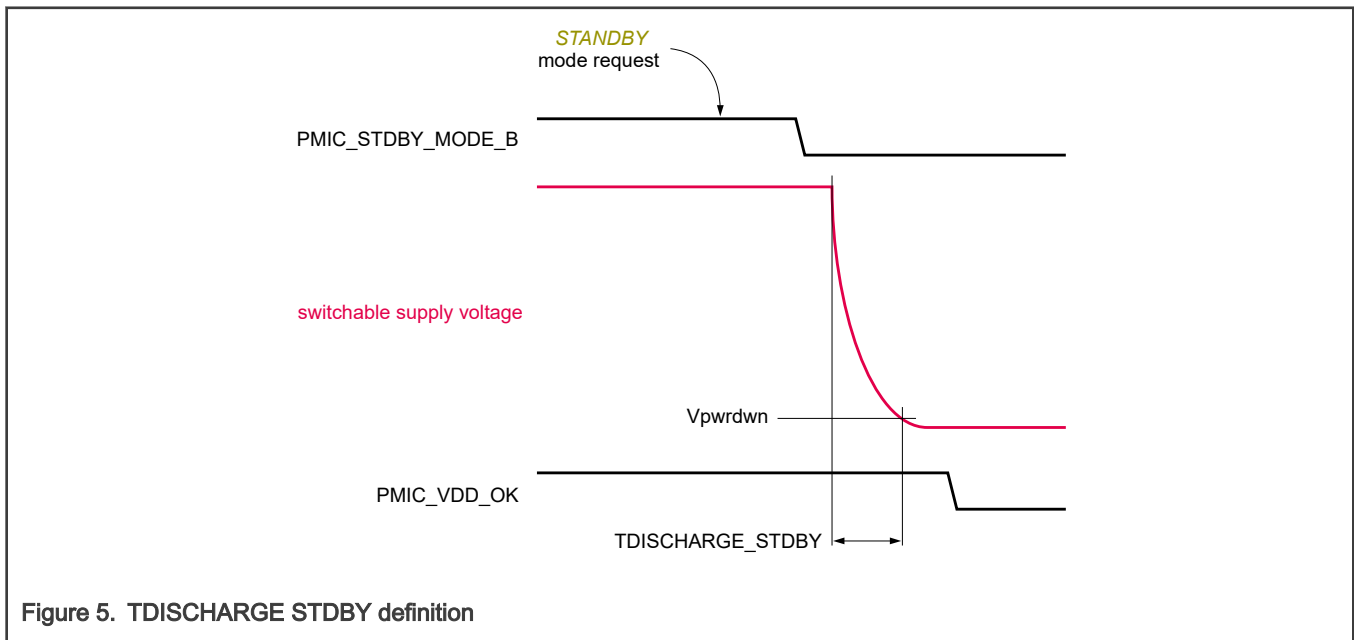

Figure 5. TDISCHARGE STDBY definition

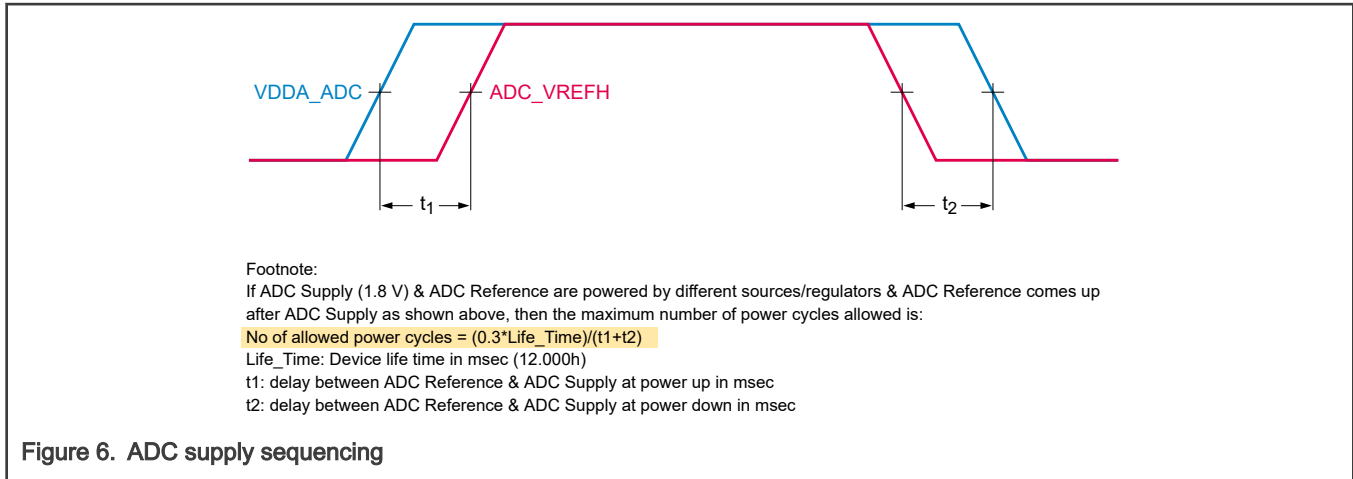

Figure 6. ADC supply sequencing

7.2 Clock frequency ranges

The following table gives the frequency range minimum and maximums to use when programming the clock dividers on the device.

Table 6. Clock frequency ranges

Symbol	Description	Min	Typ	Max	Unit	Condition	Spec Number
fA53_CORE_DIV2_CLK	Cortex-A53 core div2 clock frequency	24	—	655.5	MHz	A53_CORE_DIV2_CLK	—
fA53_CORE_DIV10_CLK	Cortex-A53 core div10 clock frequency	4.8	—	131.1	MHz	A53_CORE_DIV10_CLK	—
fLBIST_CLK	LBIST[7:0] clock frequency	—	—	50	MHz	LBIST_CLK[7:0]	—
fXBAR_CLK	XBAR clock frequency	24	—	400	MHz	XBAR_CLK	—
fXBAR_2X_CLK	XBAR 2X clock frequency	48	—	800	MHz	XBAR_2X_CLK	—
fXBAR_DIV2_CLK	XBAR div2 clock frequency	12	—	200	MHz	XBAR_DIV2_CLK	—
fXBAR_DIV3_CLK	XBAR div3 clock frequency	8	—	133	MHz	XBAR_DIV3_CLK	—
fXBAR_DIV4_CLK	XBAR div4 clock frequency	6	—	100	MHz	XBAR_DIV4_CLK	—
fXBAR_DIV6_CLK	XBAR div6 clock frequency	4	—	66.7	MHz	XBAR_DIV6_CLK	—
fDAPB_CLK	Debug clock frequency	—	—	133	MHz	fDAPB_CLK	—
fFRAY_CHI	FlexRay CHI clock frequency	—	—	133	MHz	—	—

Table continues on the next page...

Table 6. Clock frequency ranges (continued)

Symbol	Description	Min	Typ	Max	Unit	Condition	Spec Number
fSERDES_REF_CLK	SERDES reference clock frequency	100	—	125	MHz	SERDES_REF_CLK	—
fPER_CLK	Peripheral clock frequency	—	—	80	MHz	PER_CLK	—
fFTM_0_REF_CLK	FlexTimer 0 external clock frequency	—	—	20	MHz	FTM_0_REF_CLK	—
fFTM_1_REF_CLK	FlexTimer 1 external clock frequency	—	—	20	MHz	FTM_1_REF_CLK	—
fFLEXRAY_PE_CLK	FlexRay PE clock frequency	—	—	40	MHz	FLEXRAY_PE_CLK	—
fCAN_PE_CLK	CAN PE clock frequency	40	—	80	MHz	CAN_PE_CLK	—
fLIN_BAUD_CLK	LIN baud clock frequency	—	—	133	MHz	LIN_BAUD_CLK	—
fLINFLEXD_CLK	LIN clock frequency	—	—	66.7	MHz	LINFLEXD_CLK	—
fGMAC_TS_CLK	GMAC timestamp clock frequency	5	—	200	MHz	GMAC_TS_CLK	—
fGMAC_0_TX_CLK	GMAC_0 transmit clock frequency	2.5	—	125	MHz	GMAC_0_TX_CLK	—
fGMAC_0_RX_CLK	GMAC_0 receive clock frequency	2.5	—	125	MHz	GMAC_0_RX_CLK	—
fGMAC_0_REF_CLK	GMAC_0 reference clock frequency	—	—	50	MHz	GMAC_0_REF_CLK	—
fPFE_MAC_0_TX_CLK	PFE MAC_0 transmit clock frequency	2.5	—	312.5	MHz	PFE_MAC_0_TX_CLK	—
fPFE_MAC_0_RX_CLK	PFE MAC_0 receive clock frequency	2.5	—	312.5	MHz	PFE_MAC_0_RX_CLK	—
fPFE_MAC_0_REF_CLK	PFE MAC_0 reference clock frequency	—	—	50	MHz	PFE_MAC_0_REF_CLK	—
fPFE_MAC_1_TX_CLK	PFE MAC_1 transmit clock frequency	2.5	—	312.5	MHz	PFE_MAC_1_TX_CLK	—
fPFE_MAC_1_RX_CLK	PFE MAC_1 receive clock frequency	2.5	—	312.5	MHz	PFE_MAC_1_RX_CLK	—

Table continues on the next page...

Table 6. Clock frequency ranges (continued)

Symbol	Description	Min	Typ	Max	Unit	Condition	Spec Number
fPFE_MAC_1_REF_CLK	PFE MAC_1 reference clock frequency	—	—	50	MHz	PFE_MAC_1_REF_CLK	—
fPFE_MAC_2_TX_CLK	PFE MAC_2 transmit clock frequency	2.5	—	312.5	MHz	PFE_MAC_2_TX_CLK	—
fPFE_MAC_2_RX_CLK	PFE MAC_2 receive clock frequency	2.5	—	312.5	MHz	PFE_MAC_2_RX_CLK	—
fPFE_MAC_2_REF_CLK	PFE MAC_2 reference clock frequency	—	—	50	MHz	PFE_MAC_2_REF_CLK	—
fSPI_CLK	SPI clock frequency	10	—	100	MHz	SPI_CLK	—
fQSPI_2X_CLK	QSPI 2X clock frequency	—	—	400	MHz	QSPI_2X_CLK - DDR 200MHz	—
fQSPI_2X_CLK	QSPI 2X clock frequency	—	—	333	MHz	QSPI_2X_CLK - DDR 166MHz	—
fQSPI_2X_CLK	QSPI 2X clock frequency	—	—	266	MHz	QSPI_2X_CLK - DDR / SDR 133MHz	—
fQSPI_2X_CLK	QSPI 2X clock frequency	—	—	208	MHz	QSPI_2X_CLK - SDR 104MHz	—
fQSPI_2X_CLK	QSPI 2X clock frequency	—	—	200	MHz	QSPI_2X_CLK - SDR 100MHz	—
fQSPI_2X_CLK	QSPI 2X clock frequency	—	—	133	MHz	QSPI_2X_CLK - DDR 66MHz	—
fQSPI_1X_CLK	QSPI 1X clock frequency	—	—	200	MHz	QSPI_1X_CLK - DDR 200MHz	—
fQSPI_1X_CLK	QSPI 1X clock frequency	—	—	166	MHz	QSPI_1X_CLK - DDR 166MHz	—
fQSPI_1X_CLK	QSPI 1X clock frequency	—	—	133	MHz	QSPI_1X_CLK - DDR / SDR 133MHz	—
fQSPI_1X_CLK	QSPI 1X clock frequency	—	—	104	MHz	QSPI_1X_CLK - SDR 104MHz	—
fQSPI_1X_CLK	QSPI 1X clock frequency	—	—	100	MHz	QSPI_1X_CLK - SDR 100MHz	—
fQSPI_1X_CLK	QSPI 1X clock frequency	—	—	66	MHz	QSPI_1X_CLK - DDR 66MHz	—
fSDHC_CLK	uSDHC clock frequency	—	—	200	MHz	SDHC_CLK - DDR HS400	—

Table continues on the next page...

Table 6. Clock frequency ranges (continued)

Symbol	Description	Min	Typ	Max	Unit	Condition	Spec Number
fSDHC_CLK	uSDHC clock frequency	133	—	200	MHz	SDHC_CLK - DDR HS400	—
fSDHC_CLK	uSDHC clock frequency	—	—	200	MHz	SDHC_CLK - SDR HS200	—
fSDHC_CLK	uSDHC clock frequency	—	—	100	MHz	SDHC_CLK - SDR 100MHz	—
fSDHC_CLK	uSDHC clock frequency	—	—	52	MHz	SDHC_CLK - DDR / SDR 52MHz	—
fPFE_PE_CLK	PFE PE clock frequency	—	—	600	MHz	PFE_PE_CLK	—
fPFE_SYS_CLK	PFE system clock frequency	—	—	300	MHz	PFE_SYS_CLK	—

8 Thermal Characteristics

Thermal characteristics are targets based on simulation from preliminary die and package definitions. The specified characteristics are subject to change per final device design and characterization. Junction temperature is a function of die size, on-chip power dissipation, package thermal resistance, mounting site (board) temperature, ambient temperature, air flow, power dissipation of other components on the board, and board thermal resistance.

Table 7. Thermal Resistance

Board type ¹	Symbol	Description	Value	Unit
JESD51-9, 2s2p	R _{θJA}	Junction to ambient Thermal Resistance	15.6	°C/W
JESD51-9, 2s2p	Ψ _{JT}	Junction to Lid Top Thermal Resistance ²	0.3	°C/W
NA	R _{θJC}	Junction to Case Thermal Resistance ³	0.4	°C/W

1. Thermal test board meets JEDEC specification for this package (JESD51-9).
2. Determined in accordance to JEDEC JESD51-2A natural convection environment. Thermal resistance data in this report is solely for a thermal performance comparison of one package to another in a standardized specified environment. It is not meant to predict the performance of a package in an application-specific environment.
3. Junction-to-Case thermal resistance determined using an isothermal cold plate. Case temperature refers to the lid surface temperature.

9 DC electricals

9.1 Total power specifications for 0.8V and 1.8V Analog Domains

The following table contains the individual max and thermal 0.8V power figures for each device in the S32G3 family as well as a 1.8V analog total which applies to all devices. For I/O power specifications please see dedicated I/O table.

Table 8. Total power specifications for 0.8V and 1.8V Analog Domains

Symbol	Description	Min	Typ	Max	Unit	Condition	Spec Number
—	0.8V Supply Rail Power: S32G399A Max Usecase ¹	—	—	8.62	W	Tj=125C, All 0.8v supplies at 0.8V, Sum of VDD, VDD_STBY, VDD_VP_PCIE0/1, VDD_LV_PLL_DDR0, VDD_LV_PLL_AUR	—
—	0.8V Supply Rail Power: S32G399A Thermal Usecase ²	—	—	8.41	W	Tj=125C, All 0.8v supplies at 0.8V, Sum of VDD, VDD_STBY, VDD_VP_PCIE0/1, VDD_LV_PLL_DDR0, VDD_LV_PLL_AUR	—
—	0.8V Supply Rail Power: S32G398A Max Usecase ^{1,3}	—	—	8.56	W	Tj=125C, All 0.8v supplies at 0.8V, Sum of VDD, VDD_STBY, VDD_VP_PCIE0/1, VDD_LV_PLL_DDR0, VDD_LV_PLL_AUR	—
—	0.8V Supply Rail Power: S32G398A Thermal Usecase ^{2,3}	—	—	8.35	W	Tj=125C, All 0.8v supplies at 0.8V, Sum of VDD, VDD_STBY, VDD_VP_PCIE0/1, VDD_LV_PLL_DDR0, VDD_LV_PLL_AUR	—
—	0.8V Supply Rail Power: S32G379A Max Usecase ^{1,3}	—	—	8.28	W	Tj=125C, All 0.8v supplies at 0.8V, Sum of VDD, VDD_STBY, VDD_VP_PCIE0/1, VDD_LV_PLL_DDR0, VDD_LV_PLL_AUR	—
—	0.8V Supply Rail Power: S32G379A Thermal Usecase ^{2,3}	—	—	8.08	W	Tj=125C, All 0.8v supplies at 0.8V, Sum of VDD, VDD_STBY, VDD_VP_PCIE0/1, VDD_LV_PLL_DDR0, VDD_LV_PLL_AUR	—
—	0.8V Supply Rail Power: S32G378A Max Usecase ^{1,3}	—	—	8.22	W	Tj=125C, All 0.8v supplies at 0.8V, Sum of VDD,	—

Table continues on the next page...

Table 8. Total power specifications for 0.8V and 1.8V Analog Domains (continued)

Symbol	Description	Min	Typ	Max	Unit	Condition	Spec Number
						VDD_STBY, VDD_VP_PCIE0/1, VDD_LV_PLL_DDR0, VDD_LV_PLL_AUR	
—	0.8V Supply Rail Power: S32G378A Thermal Usecase ^{2,3}	—	—	8.02	W	Tj=125C, All 0.8v supplies at 0.8V, Sum of VDD, VDD_STBY, VDD_VP_PCIE0/1, VDD_LV_PLL_DDR0, VDD_LV_PLL_AUR	—
—	1.8V Analog Supply Rail power: All devices ⁴	—	—	0.135	W	Tj=125C, All 1.8V supplies at 1.8V, Sum of VDD_FXOSC, VDD_HV_PLL_AUR, VDD_HV_PLL_DDR0, VDD_ADC, VREFH_ADC0/1, VDD_FIRC, VDD_VREF, VDD_HV_PLL, VDD_TMU, VDD_DDR0	—

1. Max usecase: This is provided for power supply design. It is the realistic peak power consumption in an application. Shall only be maintained for a very short time (approx. 100us).
2. Thermal usecase: This is provided for designing a thermal solution. This is a realistic maximum sustained usecase which would be maintained for a longer duration.
3. Note that during Self Test execution, the power consumption for this device could exceed the stated spec. The S32G399A device Max Usecase spec will apply for the duration of the self test.
4. 1.8V total does not include additional consumption during a fuse programming operation. See IDD_EFUSE_PGM spec for max additional current.

9.2 Static power specifications for I/O Domains

The following table contains the static power consumption for each I/O power domain. This data does not include the usage dependent dynamic current of GPIO-pins. To estimate the dynamic GPIO current for a specific use-case, an IO calculator tool is available. For IO calculator, contact your NXP sales representative. The " Device Power and Operating Current Specifications" table contains pre-calculated total I/O power (static + dynamic) for common usecases.

Table 9. Static power specifications for I/O Domains

Symbol	Description	Min	Typ	Max	Unit	Condition	Spec Number
SPVDD_IO_A	3.3V Static Power on VDD_IO_A	—	—	2.6	mW	VDD_IO_A = 3.3V	—
SPVDD_IO_B	3.3V Static Power on VDD_IO_B	—	—	2.2	mW	VDD_IO_B = 3.3V	—
SPVDD_IO_STBY	3.3V Static Power on VDD_IO_STBY	—	—	3.1	mW	VDD_IO_STBY = 3.3V	—

Table continues on the next page...

Table 9. Static power specifications for I/O Domains (continued)

Symbol	Description	Min	Typ	Max	Unit	Condition	Spec Number
SPVDD_IO_SDHC	3.3V Static Power on VDD_IO_SDHC	—	—	159	mW	VDD_IO_SDHC = 3.3V	—
SPVDD_IO_SDHC	1.8V Static Power on VDD_IO_SDHC	—	—	12.1	mW	VDD_IO_SDHC = 1.8V	—
SPVDD_IO_GMAC0	3.3V Static Power on VDD_IO_GMAC0	—	—	150.5	mW	VDD_IO_GMAC0 = 3.3V	—
SPVDD_IO_GMAC0	1.8V Static Power on VDD_IO_GMAC0	—	—	11.4	mW	VDD_IO_GMAC0 = 1.8V	—
SPVDD_IO_GMAC1	3.3V Static Power on VDD_IO_GMAC1	—	—	151.5	mW	VDD_IO_GMAC1 = 3.3V	—
SPVDD_IO_GMAC1	1.8V Static Power on VDD_IO_GMAC1	—	—	11.5	mW	VDD_IO_GMAC1 = 1.8V	—
SPVDD_IO_USB	3.3V Static Power on VDD_IO_USB	—	—	152.6	mW	VDD_IO_USB = 3.3V	—
SPVDD_IO_USB	1.8V Static Power on VDD_IO_USB	—	—	11.4	mW	VDD_IO_USB = 1.8V	—
SPVDD_IO_QSPI	1.8V Static Power on VDD_IO_QSPI	—	—	0.5	mW	VDD_IO_QSPI = 1.8V	—
SPVDD_IO_CLKOUT	1.8V Static Power on VDD_IO_CLKOUT	—	—	0.7	mW	VDD_IO_CLKOUT = 1.8V	—
SPVDD_IO_PCIE0	1.8V Static Power on VDD_IO_PCIE0	—	—	2.8	mW	VDD_IO_PCIE0 = 1.8V	—
SPVDD_IO_PCIE1	1.8V Static Power on VDD_IO_PCIE1	—	—	2.8	mW	VDD_IO_PCIE1 = 1.8V	—
SPVDD_IO_AUR	1.8V Static Power on VDD_IO_AUR	—	—	0.8	mW	VDD_IO_AUR = 1.8V	—
SPVDD_IO_DDR	1.1V Static Power on VDD_IO_DDR - LPDDR4	—	—	2.4	mW	VDD_IO_DDR = 1.1V	—
SPVDD_IO_DDR	1.35V Static Power on VDD_IO_DDR - DDR3L	—	—	2.8	mW	VDD_IO_DDR = 1.35V	—

9.3 Device Power and Operating Current Specifications

The device power consumption, operating current, and applicable conditions are given in the following table.

NOTE

All measurements are at T_j=125C, unless otherwise specified.

Table 10. Device Power and Operating Current Specifications

Symbol	Description	Min	Typ	Max	Unit	Condition	Spec Number
PVDD_STBY	Standby mode core supply power	—	58	—	uW	Ta = 25C, VDD_STBY = 0.8V, typical silicon, all pull up/down disabled	—
PVDD_IO_STBY	Standby mode I/O supply power ¹	—	110	—	uW	Ta = 25C, VDD_IO_STBY = 3.0V, typical silicon, all pull up/down disabled	—
IDD_FXOSC	VDD_FXOSC operating current	—	0.6	—	mA	1.8V, 40MHz	—
IDD_HV_PLL_AUR	VDD_HV_PLL_AUR operating current	—	4.3	—	mA	1.8V, fPLL_VCO = 5GHz	—
IDD_HV_PLL_DDR0	VDD_HV_PLL_DDR0 operating current (DDR reference PLL only)	—	2	—	mA	fPLL_DDR_PHI0 = 800MHz, fDDR_PLL = 1600MHz, 1.8V	—
IDD_ADC	VDD_ADC operating current	—	1.8	—	mA	1.8V, 2 ADCs @ 1Msps	—
IDD_ADC	VDD_ADC operating current	—	200	—	uA	1.8V, Disabled (per ADC)	—
IVREFH_ADC	VREFH_ADC operating current	—	210	—	uA	VREFH_ADC = 1.8V	—
IDD_FIRC	VDD_FIRC operating current	—	0.6	—	mA	FIRC trimmed frequency (48MHz typical)	—
IDD_VREF	VDD_VREF operating current	—	0.7	—	mA	1.8V	—
IDD_HV_PLL	VDD_HV_PLL operating current	—	8.9	—	mA	1.8V, fPLL_VCO = 2GHz, Core / Peripheral/Accelerator PLLs	—
IDD_EFUSE_PGM	VDD_EFUSE programming current	—	—	140	mA	VDD_EFUSE=1.8V, VDD=0.8V	—
IDD_TMU	VDD_TMU operating current	—	4.6	—	mA	1.8V, central unit and remote sensors operating	—
IDD_DDR0	VDD_DDR0 operating current	—	5.0	—	mA	1.8V, fPLL_DDR_PHI0 = 800MHz, fDDR_PLL = 1600MHz	—
PVDD_IO_PCIEn	VDD_IO_PCIE0 operating power ²	—	—	76	mW	All circuits enabled, VDD_IO_PCIEn=1.8V,	—

Table continues on the next page...

Table 10. Device Power and Operating Current Specifications (continued)

Symbol	Description	Min	Typ	Max	Unit	Condition	Spec Number
						Gen3 8Gbps, 2 lanes. Per IP instance	
PVDD_IO_PCIEn	VDD_IO_PCIE0 operating power	—	—	72	mW	All circuits enabled, VDD_IO_PCIEn=1.8V, Gen2.1 5Gbps, 2 lanes. Per IP instance	—
PVDD_IO_PCIEn	VDD_IO_PCIE0 operating power	—	—	68	mW	All circuits enabled, VDD_IO_PCIEn=1.8V, Gen1.1 2.5Gbps, 2 lanes. Per IP instance	—
PVDD_IO_PCIEn	VDD_IO_PCIE0 operating power	—	—	1.5	mW	Powered down state, VDD_IO_PCIEn=1.8V, Per IP instance	—
PVDD_IO_DDR	VDD_IO_DDR 100% write operating power	—	—	625	mW	LPDDR4, VDD_IO_DDR = 1.1V, 3200 MT/s, 100% write, 1/2 data lines switching, 60 Ohm transmit termination driving a 60 Ohm load	—
PVDD_IO_DDR_IDLE	VDD_IO_DDR idle power	—	55	—	mW	LPDDR4, VDD_IO_DDR = 1.1V, Tj = 25C	—
PVDD_IO_DDR_RET	VDD_IO_DDR data retention power	—	0.02	—	mW	LPDDR4, VDD_IO_DDR = 1.1V, Standby mode and DRAM in self-refresh, Tj=25C.	—
PVDD_IO_DDR_RET	VDD_IO_DDR data retention power	—	0.030	—	mW	DDR3L, VDD_IO_DDR = 1.35V, Standby mode and DRAM in self-refresh, Tj=25C.	—
PVDD_IO_DDR	VDD_IO_DDR 100% write operating power	—	—	598	mW	DDR3L, VDD_IO_DDR = 1.35V, 1600 MT/s, 100% Write operation, 1/2 data lines switching, 60 Ohm transmit termination driving a 60 ohm load	—
PVDD_IO_DDR_IDLE	VDD_IO_DDR idle power	—	57	—	mW	DDR3L, VDD_IO_DDR = 1.35V, Tj=25C	—
PVDD_IO_QSPI	QSPI A I/O voltage supply operating power	—	58	—	mW	1.8V, 200MHz - clocks 100% activity rate, 50% data rate, 1/2 data switching per cycle,	—

Table continues on the next page...

Table 10. Device Power and Operating Current Specifications (continued)

Symbol	Description	Min	Typ	Max	Unit	Condition	Spec Number
						does not include power for other I/O ins on the VDD_IO_QSPI supply. 15.5pF.	
PVDD_IO_SDHC	VDD_IO_SDHC operating power	—	128	—	mW	1.8V, HS400, SD_CLK 100%, SD_D(8) 50%, 1/2 data switching per cycle, does not include power for other I/O pins on the VDD_IO_SDHC supply, 15.5pF	—
PVDD_IO_GMACn	VDD_IO_GMACn operating power	—	81	—	mW	1.8V, RGMII 125MHz, 100% clock rate, 50% data rate, 1/2 data switching per cycle, per IP instance, does not include power for other I/O pins on the VDD_IO_GMACn supply. 15.5pF	—
PVDD_IO_GMACn	VDD_IO_GMACn operating power	—	292	—	mW	3.3V, RGMII 125MHz, 100% clock rate, 50% data rate, 1/2 data switching per cycle, per IP instance, does not include power for other I/O pins on the VDD_IO_GMACn supply, 15.5pF.	—
PVDD_IO_USB_TYP	USB I/O voltage supply operating power	—	59	—	mW	1.8V, modem - 8 outputs @60MHz, 50% data rate, 1/2 data switching per cycle, does not include power for other I/O pins on the VDD_IO_USB supply. 15.5pF.	—
PVDD_IO_USB_TYP	USB I/O voltage supply operating power	—	174	—	mW	3.3V, modem - 8 outputs @60MHz, 50% data rate, 1/2 data switching per cycle, does not include power for the other I/O pins on the VDD_IO_USB supply. 15.5pF	—

Table continues on the next page...

Table 10. Device Power and Operating Current Specifications (continued)

Symbol	Description	Min	Typ	Max	Unit	Condition	Spec Number
PVDD_IO_AUR	Aurora I/O voltage supply operating power	—	164	—	mW	1.8V, 5Gbps on 4 lanes, 50% Activity Rate, 1/2 data switching per cycle	—

1. This spec includes the consumption on pins in VDD_STBY_IO domain only. See the hardware design guide for more details.
2. This specification can be considered a worst case maximum for any valid 2 x lane SerDes configuration (including PCIe/SGMII or SGMII only modes).

10 Power sequencing

10.1 Power-up

The following sequence has been validated by NXP and is to be followed when powering up the device. Each supply within a step must be within its specified operating voltage range before the next step in the sequence is started, except as noted below.

1. Set POR_B input to low value.
2. Ramp up VDD_IO_STBY supply.

VDD_IO_B can optionally be included with VDD_IO_STBY in the first step.

3. Ramp up all GPIO supplies powered to 3.3V.
4. Ramp up all 1.8V supplies including GPIO supplies powered to 1.8V

Step 5 and 6 can commence in the following sequence prior to all 1.8V supplies reaching DC tolerance. Step 5 must still reach DC tolerance before Step 6.

5. Ramp up VDD_DDR_IO supply
6. Ramp up all 0.8V supplies
7. Set POR_B and PMIC_VDD_OK inputs to high value once all supplies have reached their specified levels.

NOTE

For step 4, it is acceptable for the 1.8V supplies to not yet be within their specified range at the time of asserting the PMIC_VDD_OK input when exiting Standby mode if it is ensured that they are within their specified range no later than 140 us after the PMIC_VDD_OK input assertion. VDD_IO_QSPI (a 1.8V GPIO supply) has the additional option to ramp with step 3 instead of step 4.

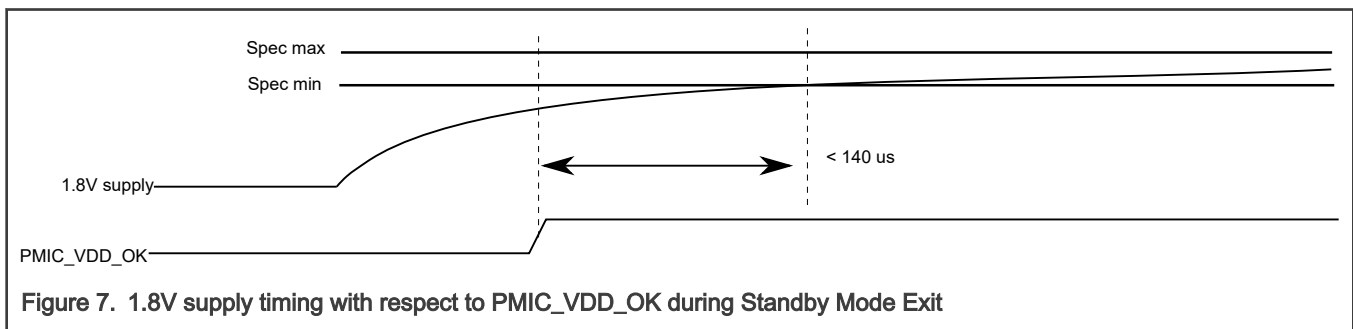

Figure 7. 1.8V supply timing with respect to PMIC_VDD_OK during Standby Mode Exit

NOTE

While powering up the device, the VDD_EFUSE supply pin must be kept powered down. While the device is already powered up, the VDD_EFUSE supply pin can be powered up/down independent of the other supplies on the device. The VDD_EFUSE supply pin must be powered down prior to Standby mode entry or, at the latest, powered down together with the other 1.8V supplies during Standby mode entry.

Table 11. Power-up

Symbol	Description	Min	Typ	Max	Unit	Condition	Spec Number
Vpwrdown	Maximum voltage on a supply pin in powerdown mode	—	—	100	mV	—	—

The power-up sequence on Standby exit is the same except that only the switchable supplies that were powered down during Standby mode are ramped up again, and the POR_B input is kept high throughout the sequence.

10.2 Power-down

When powering down the SoC, it is recommended to use the reverse order from the power-up sequence. If this cannot be achieved, ensure that all supplies are below the Vpwrdown level before powering up again.

11 Electromagnetic compatibility (EMC)

EMC measurements to IC-level IEC standards are available from NXP Semiconductor on request.

12 GPIO Pads

Table 12. GPIO Pads

Symbol	Description	Min	Typ	Max	Unit	Condition	Spec Number
VIH	Input high level DC voltage threshold	0.7 * VDD_IO_*	—	—	V	1.8V / 3.3V	—
VIL	Input low level DC voltage threshold	—	—	0.3 * VDD_IO_*	V	1.8V / 3.3V	—
VOL	GPIO output low voltage ¹	—	—	20% * VDD_IO_*	V	—	—
VOH	GPIO output high voltage ¹	80% * VDD_IO_*	—	—	V	—	—
VHYS_33	3.3V GPIO input hysteresis voltage	100	—	—	mV	Always enabled.	—
ILKG_18	1.8V GPIO pad input leakage current	-17	—	17	uA	1.8V, Tj = 125C	—

Table continues on the next page...

Table 12. GPIO Pads (continued)

Symbol	Description	Min	Typ	Max	Unit	Condition	Spec Number
ILKG_33	3.3V GPI / GPIO pad input leakage current	-30	—	30	uA	3.3V, T _j = 125C	—
ILKG_3318	1.8V/3.3V GPIO pad input leakage current (3.3V)	-50	—	50	uA	3.3V, T _j = 125C	—
ILKG_3318	1.8V/3.3V GPIO pad input leakage current (1.8V)	-17	—	17	uA	1.8V, T _j = 125C	—
CIN_18	Input capacitance (1.8V GPIO)	—	6	8	pF	—	—
CIN_33	Input capacitance (3.3V GPI / GPIO)	—	7	11	pF	—	—
CIN_3318	Input capacitance (1.8V/3.3V GPIO)	—	7	11	pF	—	—
ISLEW	Input signal slew rate ²	1	—	4	V/ns	—	—
ITR_TF	Input signal rise/fall time ^{2,3}	0.5	—	2	ns	—	—
TPW_MIN	Input minimum pulse width	2	—	—	ns	—	—
FMAX_IN_18	1.8V GPIO maximum input frequency ⁴	—	—	50	MHz	CMOS Receiver	—
FMAX_IN_18	1.8V GPIO maximum input frequency ⁴	—	—	208	MHz	VREF Receiver	—
FMAX_IN_3318	1.8V/3.3V GPIO maximum input frequency ⁴	—	—	208	MHz	1.8V	—
FMAX_IN_3318	1.8V/3.3V GPIO maximum input frequency ⁴	—	—	166.7	MHz	3.3V	—
FMAX_IN_33	3.3V GPIO maximum input frequency ⁴	—	—	50	MHz	—	—
IPU_18	1.8V GPIO pull up/down resistance	9	18	23	kΩ	pull up @ 0.3 * VDD_HV_IO, pull down @ 0.7 * VDD_HV_IO	—
IPU_33	3.3V GPIO pull up/down resistance	9	18	23	kΩ	pull up @ 0.3 * VDD_HV_IO, pull down @ 0.7 * VDD_HV_IO	—

Table continues on the next page...

Table 12. GPIO Pads (continued)

Symbol	Description	Min	Typ	Max	Unit	Condition	Spec Number
IPU_3318	1.8V/3.3V GPIO pull up/down resistance	9	18	23	k Ω	pull up @ 0.3 * VDD_HV_IO, pull down @ 0.7 * VDD_HV_IO	—
RDSON_18	1.8V GPIO output impedance (NMOS & PMOS) ⁵	27.0	36.3	48.0	Ω	SRE[2:0] = xxx, 50% * VDD_IO_*	—
RDSON_3318	1.8V/3.3V GPIO output impedance (NMOS & PMOS) at 1.8V ⁵	18.0	30.0	43.0	Ω	SRE[2:0] = 000, 50% * VDD_IO_*	—
RDSON_3318	1.8V/3.3V GPIO output impedance (NMOS & PMOS) at 1.8V ⁵	19.0	30.0	44.0	Ω	SRE[2:0] = 100, 50% * VDD_IO_*	—
RDSON_3318	1.8V/3.3V GPIO output impedance (NMOS & PMOS) at 1.8V ⁵	21.0	33.0	49.0	Ω	SRE[2:0] = 101, 50% * VDD_IO_*	—
RDSON_3318	1.8V/3.3V GPIO output impedance (NMOS & PMOS) at 1.8V ⁵	23.0	37.5	58.0	Ω	SRE[2:0] = 110, 50% * VDD_IO_*	—
RDSON_3318	1.8V/3.3V GPIO output impedance (NMOS & PMOS) at 1.8V ⁵	24.0	37.5	57.0	Ω	SRE[2:0] = 111, 50% * VDD_IO_*	—
RDSON_3318	1.8V/3.3V GPIO output impedance (NMOS & PMOS) at 3.3V ⁵	18.0	30.0	43.0	Ω	SRE[2:0] = 000, 50% * VDD_IO_*	—
RDSON_3318	1.8V/3.3V GPIO output impedance (NMOS & PMOS) at 3.3V ⁵	19.0	30.0	44.0	Ω	SRE[2:0] = 100, 50% * VDD_IO_*	—
RDSON_3318	1.8V/3.3V GPIO output impedance (NMOS & PMOS) at 3.3V ⁵	21.0	33.4	50.0	Ω	SRE[2:0] = 101, 50% * VDD_IO_*	—
RDSON_3318	1.8V/3.3V GPIO output impedance (NMOS & PMOS) at 3.3V ⁵	23.0	39.5	61.0	Ω	SRE[2:0] = 110, 50% * VDD_IO_*	—

Table continues on the next page...

Table 12. GPIO Pads (continued)

Symbol	Description	Min	Typ	Max	Unit	Condition	Spec Number
RDSON_3318	1.8V/3.3V GPIO output impedance (NMOS & PMOS) at 3.3V ⁵	26.0	39.5	61.0	Ω	SRE[2:0] = 111, 50% * VDD_IO_*	—
RDSON_33	3.3V GPIO output impedance (NMOS & PMOS) ⁵	16.5	26.5	42.0	Ω	SRE[2:0] = 000, 50% * VDD_IO_*	—
RDSON_33	3.3V GPIO output impedance (NMOS & PMOS) ⁵	16.5	26.5	42.0	Ω	SRE[2:0] = 100, 50% * VDD_IO_*	—
RDSON_33	3.3V GPIO output impedance (NMOS & PMOS) ⁵	19.2	30.5	49.5	Ω	SRE[2:0] = 101, 50% * VDD_IO_*	—
RDSON_33	3.3V GPIO output impedance (NMOS & PMOS) ⁵	24.5	38.0	61.5	Ω	SRE[2:0] = 110, 50% * VDD_IO_*	—
RDSON_33	3.3V GPIO output impedance (NMOS & PMOS) ⁵	32.0	48.0	75.5	Ω	SRE[2:0] = 111, 50% * VDD_IO_*	—
IOH_18	1.8V GPIO output high current ⁵	-15.0	—	-6.0	mA	SRE[2:0] = xxx, 80% * VDD_IO_*	—
IOL_18	1.8V GPIO output low current ⁵	6.0	—	15.0	mA	SRE[2:0] = xxx, 20% * VDD_IO_*	—
IOH_3318	1.8V/3.3V GPIO output high current at 1.8V ⁵	-22	—	-8	mA	SRE[2:0] = 000, 80% * VDD_IO_*	—
IOH_3318	1.8V/3.3V GPIO output high current at 1.8V ⁵	-21	—	-8	mA	SRE[2:0] = 100, 80% * VDD_IO_*	—
IOH_3318	1.8V/3.3V GPIO output high current at 1.8V ⁵	-19	—	-6	mA	SRE[2:0] = 101, 80% * VDD_IO_*	—
IOH_3318	1.8V/3.3V GPIO output high current at 1.8V ⁵	-17	—	-6	mA	SRE[2:0] = 110, 80% * VDD_IO_*	—
IOH_3318	1.8V/3.3V GPIO output high current at 1.8V ⁵	-17	—	-6	mA	SRE[2:0] = 111, 80% * VDD_IO_*	—
IOL_3318	1.8V/3.3V GPIO output low current at 1.8V ⁵	8	—	22	mA	SRE[2:0] = 000, 20% * VDD_IO_*	—

Table continues on the next page...

Table 12. GPIO Pads (continued)

Symbol	Description	Min	Typ	Max	Unit	Condition	Spec Number
IOL_3318	1.8V/3.3V GPIO output low current at 1.8V ⁵	8	—	21	mA	SRE[2:0] = 100, 20% * VDD_IO_*	—
IOL_3318	1.8V/3.3V GPIO output low current at 1.8V ⁵	6	—	20	mA	SRE[2:0] = 101, 20% * VDD_IO_*	—
IOL_3318	1.8V/3.3V GPIO output low current at 1.8V ⁵	6	—	18	mA	SRE[2:0] = 110, 20% * VDD_IO_*	—
IOL_3318	1.8V/3.3V GPIO output low current at 1.8V ⁵	6	—	17	mA	SRE[2:0] = 111, 20% * VDD_IO_*	—
IOH_3318	1.8V/3.3V GPIO output high current at 3.3V ⁵	-40	—	-14	mA	SRE[2:0] = 000, 80% * VDD_IO_*	—
IOH_3318	1.8V/3.3V GPIO output high current at 3.3V ⁵	-40	—	-14	mA	SRE[2:0] = 100, 80% * VDD_IO_*	—
IOH_3318	1.8V/3.3V GPIO output high current at 3.3V ⁵	-35	—	-10	mA	SRE[2:0] = 101, 80% * VDD_IO_*	—
IOH_3318	1.8V/3.3V GPIO output high current at 3.3V ⁵	-32	—	-10	mA	SRE[2:0] = 110, 80% * VDD_IO_*	—
IOH_3318	1.8V/3.3V GPIO output high current at 3.3V ⁵	-32	—	-10	mA	SRE[2:0] = 111, 80% * VDD_IO_*	—
IOL_3318	1.8V/3.3V GPIO output low current at 3.3V ⁵	15	—	40	mA	SRE[2:0] = 000, 20% * VDD_IO_*	—
IOL_3318	1.8V/3.3V GPIO output low current at 3.3V ⁵	15	—	40	mA	SRE[2:0] = 100, 20% * VDD_IO_*	—
IOL_3318	1.8V/3.3V GPIO output low current at 3.3V ⁵	13	—	36	mA	SRE[2:0] = 101, 20% * VDD_IO_*	—
IOL_3318	1.8V/3.3V GPIO output low current at 3.3V ⁵	12	—	33	mA	SRE[2:0] = 110, 20% * VDD_IO_*	—
IOL_3318	1.8V/3.3V GPIO output low current at 3.3V ⁵	11	—	32	mA	SRE[2:0] = 111, 20% * VDD_IO_*	—

Table continues on the next page...

Table 12. GPIO Pads (continued)

Symbol	Description	Min	Typ	Max	Unit	Condition	Spec Number
IOH_33	3.3V GPIO output high current ⁵	-40.1	—	-14.0	mA	SRE[2:0] = 000, 80% * VDD_IO_*	—
IOH_33	3.3V GPIO output high current ⁵	-40.1	—	-14.0	mA	SRE[2:0] = 100, 80% * VDD_IO_*	—
IOH_33	3.3V GPIO output high current ⁵	-36.2	—	-12.1	mA	SRE[2:0] = 101, 80% * VDD_IO_*	—
IOH_33	3.3V GPIO output high current ⁵	-32.0	—	-10.3	mA	SRE[2:0] = 110, 80% * VDD_IO_*	—
IOH_33	3.3V GPIO output high current ⁵	-29.0	—	-9.0	mA	SRE[2:0] = 111, 80% * VDD_IO_*	—
IOL_33	3.3V GPIO output low current ⁵	14.6	—	39.4	mA	SRE[2:0] = 000, 20% * VDD_IO_*	—
IOL_33	3.3V GPIO output low current ⁵	14.6	—	39.4	mA	SRE[2:0] = 100, 20% * VDD_IO_*	—
IOL_33	3.3V GPIO output low current ⁵	13.0	—	35.5	mA	SRE[2:0] = 101, 20% * VDD_IO_*	—
IOL_33	3.3V GPIO output low current ⁵	11.2	—	32.0	mA	SRE[2:0] = 110, 20% * VDD_IO_*	—
IOL_33	3.3V GPIO output low current ⁵	10.0	—	29.0	mA	SRE[2:0] = 111, 20% * VDD_IO_*	—
FMAX_18	1.8V GPIO maximum output frequency ^{5, 6}	—	—	208	MHz	SRE[2:0] = 000	—
FMAX_18	1.8V GPIO maximum output frequency ^{5, 6}	—	—	150	MHz	SRE[2:0] = 100	—
FMAX_18	1.8V GPIO maximum output frequency ^{5, 6}	—	—	133	MHz	SRE[2:0] = 101	—
FMAX_18	1.8V GPIO maximum output frequency ^{5, 6}	—	—	100	MHz	SRE[2:0] = 110	—
FMAX_18	1.8V GPIO maximum output frequency ^{5, 6}	—	—	50	MHz	SRE[2:0] = 111	—
FMAX_33	3.3V GPIO maximum output frequency ^{5, 6}	—	—	50	MHz	SRE[2:0] = 100	—

Table continues on the next page...

Table 12. GPIO Pads (continued)

Symbol	Description	Min	Typ	Max	Unit	Condition	Spec Number
FMAX_33	3.3V GPIO maximum output frequency ^{5, 6}	—	—	50	MHz	SRE[2:0] = 101, reduced slew relative to the SRE[2:0] = 100 setting for the same output load.	—
FMAX_33	3.3V GPIO maximum output frequency ^{5, 6}	—	—	50	MHz	SRE[2:0] = 110	—
FMAX_33	3.3V GPIO maximum output frequency ^{5, 6}	—	—	1	MHz	SRE[2:0] = 111	—
FMAX_3318	1.8V/3.3V GPIO maximum output frequency ^{5, 6}	—	—	208	MHz	SRE[2:0] = 000, 1.8V	—
FMAX_3318	1.8V/3.3V GPIO maximum output frequency ^{5, 6}	—	—	166.7	MHz	SRE[2:0] = 100, 1.8V	—
FMAX_3318	1.8V/3.3V GPIO maximum output frequency ^{5, 6}	—	—	150	MHz	SRE[2:0] = 101, 1.8V	—
FMAX_3318	1.8V/3.3V GPIO maximum output frequency ^{5, 6}	—	—	133.3	MHz	SRE[2:0] = 110, 1.8V	—
FMAX_3318	1.8V/3.3V GPIO maximum output frequency ^{5, 6}	—	—	100	MHz	SRE[2:0] = 111, 1.8V	—
FMAX_3318	1.8V/3.3V GPIO maximum output frequency ^{5, 6}	—	—	166.7	MHz	SRE[2:0] = 000, 3.3V	—
FMAX_3318	1.8V/3.3V GPIO maximum output frequency ^{5, 6}	—	—	150	MHz	SRE[2:0] = 100, 3.3V	—
FMAX_3318	1.8V/3.3V GPIO maximum output frequency ^{5, 6}	—	—	133.3	MHz	SRE[2:0] = 101, 3.3V	—
FMAX_3318	1.8V/3.3V GPIO maximum output frequency ^{5, 6}	—	—	100	MHz	SRE[2:0] = 110, 3.3V	—
FMAX_3318	1.8V/3.3V GPIO maximum output frequency ^{5, 6}	—	—	83.3	MHz	SRE[2:0] = 111, 3.3V	—

Table continues on the next page...

Table 12. GPIO Pads (continued)

Symbol	Description	Min	Typ	Max	Unit	Condition	Spec Number
TR_TF_3318	1.8V/3.3V GPIO rise/fall time at 1.8V 5, 6, 7	1.0	—	5.5	V/ns	SRE[2:0] = 000	—
TR_TF_3318	1.8V/3.3V GPIO rise/fall time at 1.8V 5, 6, 7	1.0	—	5.75	V/ns	SRE[2:0] = 100	—
TR_TF_3318	1.8V/3.3V GPIO rise/fall time at 1.8V 5, 6, 7	0.75	—	4.75	V/ns	SRE[2:0] = 101	—
TR_TF_3318	1.8V/3.3V GPIO rise/fall time at 1.8V 5, 6, 7	0.5	—	4.5	V/ns	SRE[2:0] = 110	—
TR_TF_3318	1.8V/3.3V GPIO rise/fall time at 1.8V 5, 6, 7	0.5	—	4.0	V/ns	SRE[2:0] = 111	—
TR_TF_3318	1.8V/3.3V GPIO rise/fall time at 3.3V 5, 6, 7	2.0	—	10.5	V/ns	SRE[2:0] = 000	—
TR_TF_3318	1.8V/3.3V GPIO rise/fall time at 3.3V 5, 6, 7	2.0	—	9.25	V/ns	SRE[2:0] = 100	—
TR_TF_3318	1.8V/3.3V GPIO rise/fall time at 3.3V 5, 6, 7	1.5	—	9.5	V/ns	SRE[2:0] = 101	—
TR_TF_3318	1.8V/3.3V GPIO rise/fall time at 3.3V 5, 6, 7	0.75	—	7.5	V/ns	SRE[2:0] = 110	—
TR_TF_3318	1.8V/3.3V GPIO rise/fall time at 3.3V 5, 6, 7	0.75	—	7.25	V/ns	SRE[2:0] = 111	—
TR_TF_18	1.8V GPIO rise/fall time 5, 6, 7	0.75	—	3.75	V/ns	SRE[2:0] = 000	—
TR_TF_18	1.8V GPIO rise/fall time 5, 6, 7	0.75	—	3.75	V/ns	SRE[2:0] = 100	—
TR_TF_18	1.8V GPIO rise/fall time 5, 6, 7	0.75	—	3.25	V/ns	SRE[2:0] = 101	—
TR_TF_18	1.8V GPIO rise/fall time 5, 6, 7	0.75	—	3.25	V/ns	SRE[2:0] = 110	—
TR_TF_18	1.8V GPIO rise/fall time 5, 6, 7	0.25	—	3.25	V/ns	SRE[2:0] = 111	—
TR_TF_33	3.3V GPIO rise/fall time 5, 6, 7	1.75	—	9.0	V/ns	SRE[2:0] = 000	—
TR_TF_33	3.3V GPIO rise/fall time 5, 6, 7	1.90	—	9.0	V/ns	SRE[2:0] = 100	—
TR_TF_33	3.3V GPIO rise/fall time 5, 6, 7	1.00	—	8.50	V/ns	SRE[2:0] = 101	—
TR_TF_33	3.3V GPIO rise/fall time 5, 6, 7	0.50	—	7.30	V/ns	SRE[2:0] = 110	—

Table continues on the next page...

Table 12. GPIO Pads (continued)

Symbol	Description	Min	Typ	Max	Unit	Condition	Spec Number
TR_TF_33	3.3V GPIO rise/fall time ^{5, 6, 7}	0.40	—	6.0	V/ns	SRE[2:0] = 111	—
WISE_33	3.3V GPIO pad indeterminate state end threshold	—	2.35	—	V	See 1.8V and 3.3V GPIO pad detailed behavior diagram below	—
WISE_3318	1.8V/3.3V GPIO pad indeterminate state end threshold	—	1.53	—	V	See 1.8V/3.3V GPIO pad detailed behavior diagram below	—
WISE_18	1.8V GPIO pad indeterminate state end threshold	—	0.6	—	V	See 1.8V and 3.3V GPIO pad detailed behavior diagram below	—

- For current at this voltage see IOL/IOH specs respectively.
- Fastest slew rate and lowest rise/fall time constraint required to meet high-speed interface timing such as QSPI, RGMII, and uSDHC. Slower input transitions can be used for input signals with slow switching rates (<40 MHz).
- The ISLEW has precedence over ITR_TF if the ITR_TF violates the implied range for a given ISLEW.
- Input slew rate and rise/fall time limits must be adhered to in conjunction with the max input frequency limits given for proper operation.
- GPIO output transition time information can be obtained from the device IBIS model. IBIS models are recommended for system level simulations, as discrete values for I/O transition times are not representative of the I/O pad behavior when connected to an actual transmission line load.
- I/O timing specifications are valid for the un-terminated 50ohm transmission line reference load given in the figure below. A lumped 8pF load is assumed at the end of a 5 inch microstrip trace on standard FR4 with approximately 1.5pF/inch. For signals with frequency greater than 63MHz, a maximum 2 inch PCB trace is assumed. For best signal integrity, the series resistance in the transmission line should be matched closely to the selected R_{DSO}N of the I/O pad output.
- Rise/fall time specifications are derived from simulation model for the defined operating points (between 20% and 80% of VDD_HV_IO level). Actual application rise/fall time should be extracted from IBIS model simulations with the microcontroller models and application PCB.

NOTE

In the Standby mode exit case, the rising edge of the PMIC_VDD_OK pin determines when the pads enter their 'POR value' state instead of the POR_B pin.

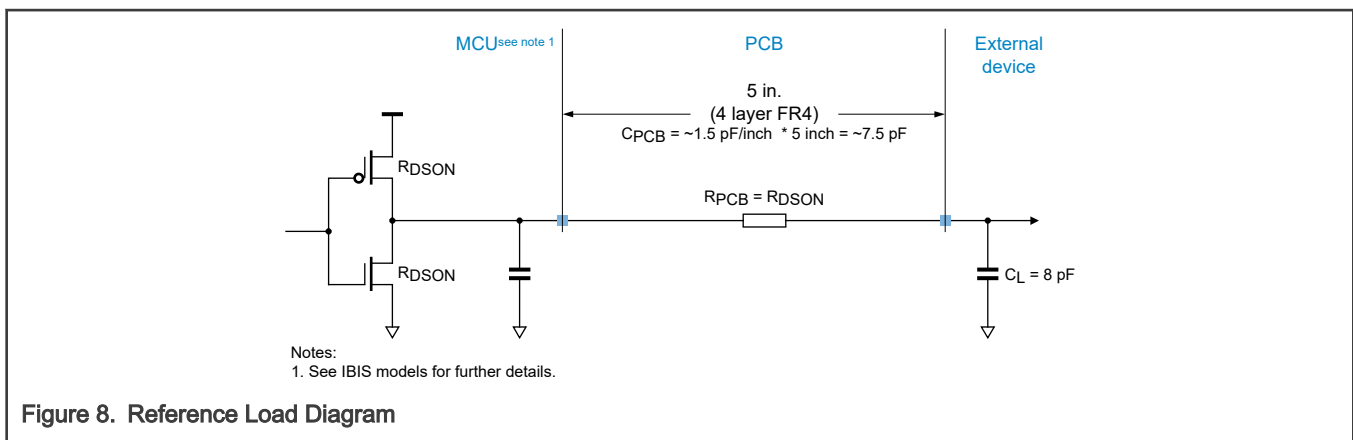

Figure 8. Reference Load Diagram

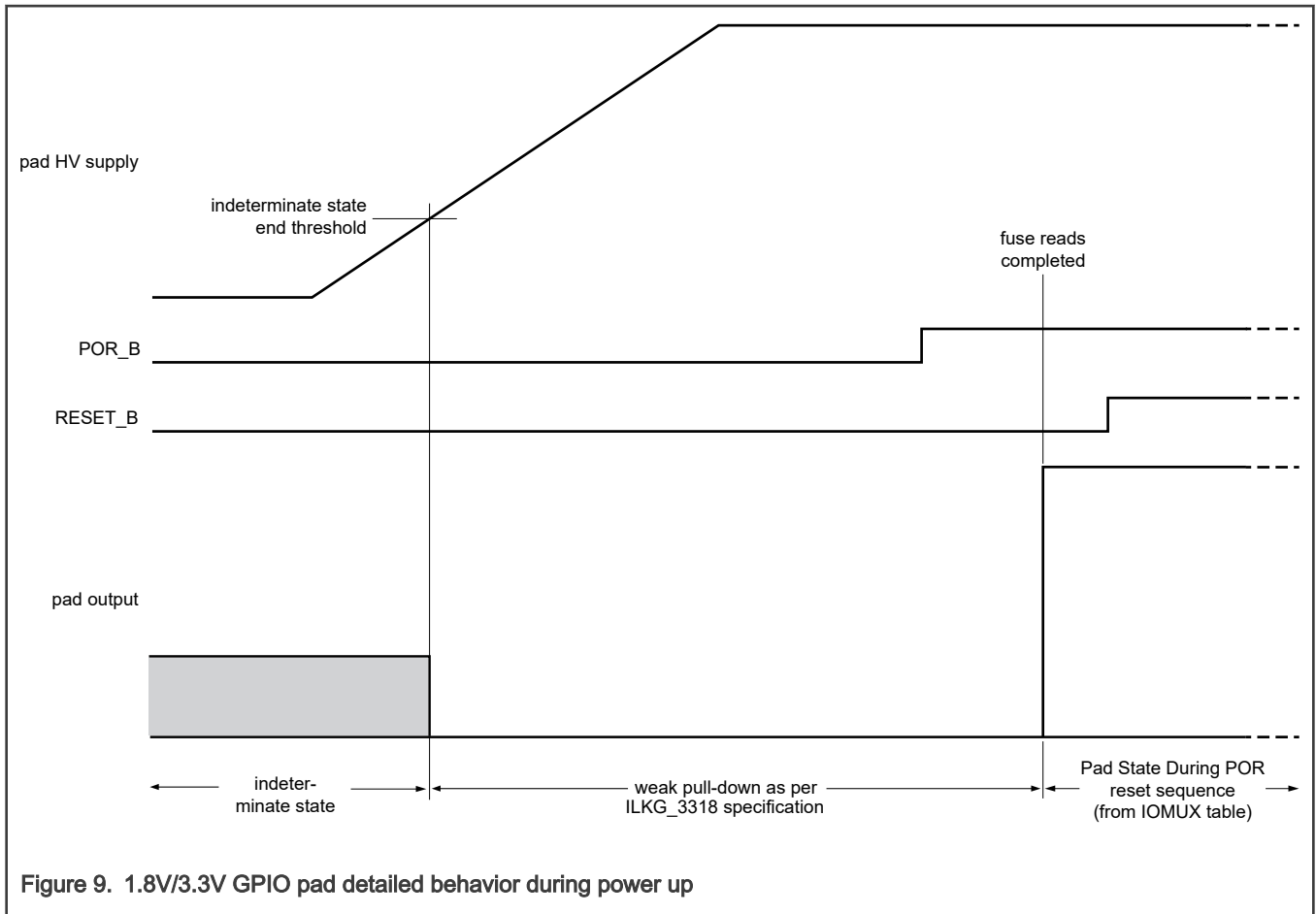

Figure 9. 1.8V/3.3V GPIO pad detailed behavior during power up

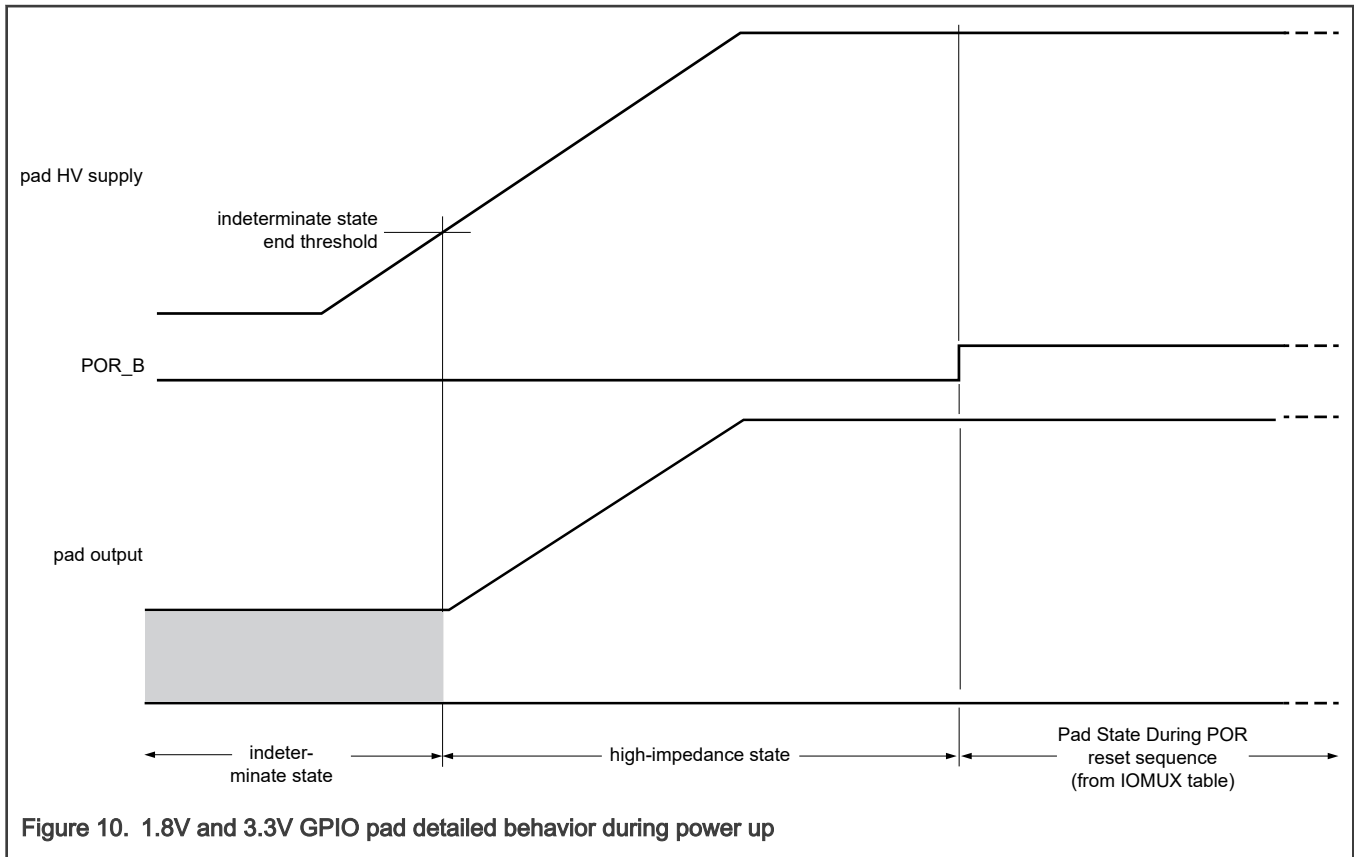

Figure 10. 1.8V and 3.3V GPIO pad detailed behavior during power up

The high-impedance state level is shown based on the external pull-up being on the corresponding pad supply.

13 Aurora specifications

13.1 Aurora Pads

Table 13. Aurora Pads

Symbol	Description	Min	Typ	Max	Unit	Condition	Spec Number
fAURORA	Data Rate	0.05	—	5.0	Gbps	100Ω external termination (Not on board but inside receiver after AC coupling)	—
IDD_HV_AUR	Transmitter HV supply current consumption (No pre-emphasis)	18	22	31	mA	max fAURORA per active transmit lane	—
IDD_HV_AUR	Transmitter HV supply current consumption (pre-emphasis enabled ,	25	30	40	mA	max fAURORA per active transmit lane	—

Table continues on the next page...

Table 13. Aurora Pads (continued)

Symbol	Description	Min	Typ	Max	Unit	Condition	Spec Number
	pre-emphasis gain=11)						
VOD_AURORA_AC	Transmitter Differential output voltage (end termination) ^{1, 2, 3}	400	600	900	mV	max fAURORA, 100Ω termination, 100Ω differential transmission line delay, matched network	—
VOD_AURORA_DC	DC range for the VOD (Transmitter Differential Output Voltage)	800	—	—	mV	ipp_obe=1 DC condition	—
VOD_AURORA_AC_PRE_EMPH	Transmitter Differential output voltage (end termination, preemph=11) ^{1, 2, 4}	600	900	1200	mV	max fAURORA, 100Ω termination, 100Ω differential transmission line delay, matched network	—
VCM_AURORA	Transmitter Common mode voltage	0.775	—	1.025	V	—	—
VCM_LVDS_RX	Receiver input signal common mode range	0.6	—	1.0	V	—	—
VDIFF_LVDS_RX	Receiver input differential signal	400	—	—	mV	—	—
CLOAD_AURORA	Maximum transmission line load (Lumped Load at any point on Tline)	—	—	0.1	pF	—	—
RTERM_AURORA	Internal termination resistance	80	100	130	Ohm	enabled	—
VSLEW_AURORA	Differential output slew rate	—	30	50	ps / 200mV	max fAURORA	—
TSTARTUP_AURORA	Transmitter startup time (assertion of ipp_obe to common mode settling of differential output)	—	—	500	ns	—	—
TEYE_AURORA	Valid data region (Including PLL Jitter for Aurora) ⁵	0.55	—	—	UI	max fAURORA	—

Table continues on the next page...

Table 13. Aurora Pads (continued)

Symbol	Description	Min	Typ	Max	Unit	Condition	Spec Number
VOH_AURORA	Transmitter output high indicator ⁶	$VDD_IO/2 + 0.2$	—	—	V	100Ω termination at receiver end	—
VOL_AURORA	Transmitter output low indicator ⁶	—	—	$VDD_IO/2 - 0.2$	V	100Ω termination at receiver end	—
PAD_P_BIAS	Pad_p voltage output level when Tx disabled	—	—	0.6	V	lpp_obe_lv=0 lpp_term_en_lv=0	—
PAD_N_BIAS	Pad_n voltage output level when Tx disabled	1.1	—	—	V	lpp_obe_lv=0 lpp_term_en_lv=0	—

- When operating at max speed, there will be losses and differential output will be smaller as against DC condition. Aurora Interface Min differential swing is 400mV which is always guaranteed but the max limit is dependent on board design/ losses. For boards with negligible losses , if differential output (P-N) goes higher than 800mV (Aurora max differential input spec) , user must use “dual termination” scheme as highlighted in the Source Termination Circuit Figure to get the differential swing back within Range. The termination in the source side can be enabled through software in the transmitter pad design. Direct end termination without AC coupling is not allowed.
- Termination scheme as shown in the End Termination Circuit Figure. Direct end termination without AC coupling is not allowed.
- Differential output is with pre-emphasis disabled, and a 10mA output stage current.
- Differential output is with pre-emphasis enabled, and a ~15mA avg output stage current
- UI @ 5Gbps equals 200ps. The valid eye is expected to be > 110ps in width. ISI jitter spec is 20-30ps for the LVDS transmitter across PVT in a delay matched differential transmission line impedance of 100Ω.
- VDD_IO maps to corresponding supply name on the device.

Termination scheme as shown in “End Termination Circuit” applies to debug tool hardware and is not recommended to be placed on the PC.

Source termination Circuit – Transmitter side 100 ohm termination is present inside the Tx pad and should not be placed on the PCB.

Direct 100 ohm board termination not allowed between AUR_TXn_N and AUR_TXn_N (n=0,1,2,3). Source termination is only allowed through the internal termination inside LVDS Tx pad.

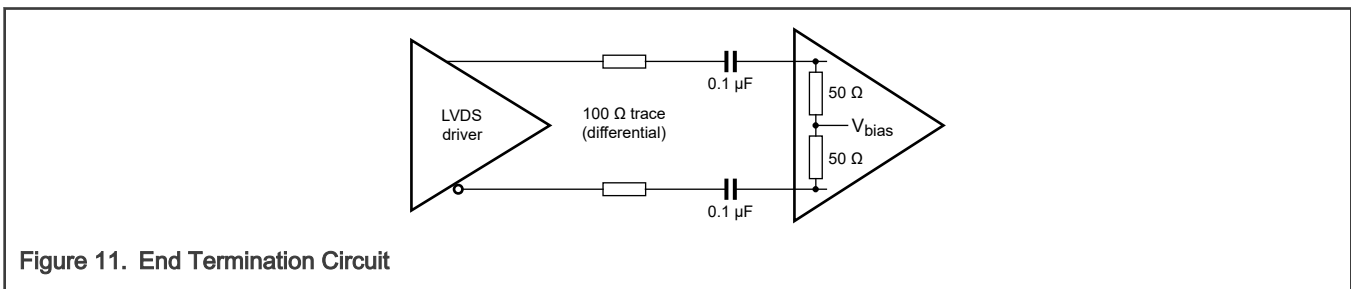

Figure 11. End Termination Circuit

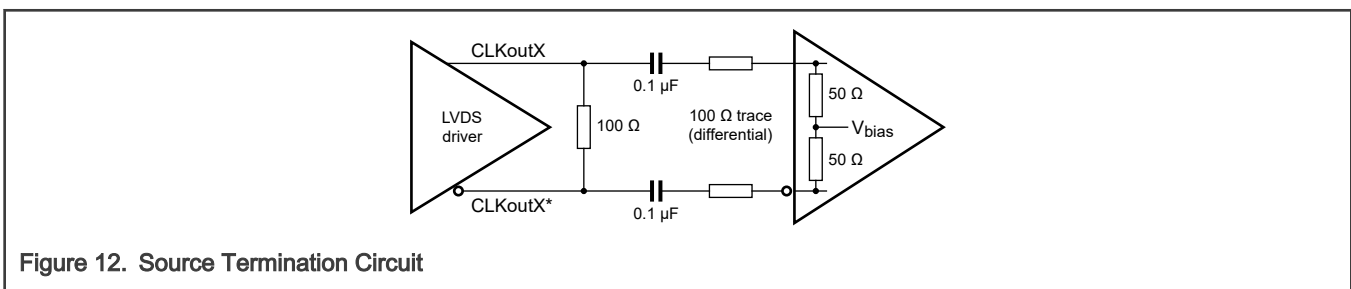

Figure 12. Source Termination Circuit

13.2 Aurora Port Timing

The following table gives the Aurora Port interface timing specifications for the device.

Table 14. Aurora Port Timing

Symbol	Description	Min	Typ	Max	Unit	Condition	Spec Number
BER	Bit Error Rate	—	—	10e-12	—	—	—
JD	Transmit line deterministic jitter	—	—	0.17	OUI	data rate <=3.0 Gbps	—
JD	Transmit line deterministic jitter	—	—	0.25	OUI	3.0Gbps < data rate <= 5.0Gbps	—
JT	Transmit line total jitter	—	—	0.35	OUI	data rate <= 3.0 Gbps	2
JT	Transmit line total jitter	—	—	0.45	OUI	3.0Gbps < data rate <= 5.0Gbps	2
SO	Differential output skew	—	—	20	ps	—	3
SMO	Lane to lane output skew	—	—	1000	ps	—	4
OUI	Aurora lane unit interval ^{1,2}	—	500	—	ps	2.0 Gbps	5
OUI	Aurora lane unit interval ^{1,2}	—	400	—	ps	2.5 Gbps	5
OUI	Aurora lane unit interval ^{1,2}	—	333	—	ps	3.0 Gbps	5
OUI	Aurora lane unit interval ^{1,2}	—	294	—	ps	3.4 Gbps	5
OUI	Aurora lane unit interval ^{1,2}	—	250	—	ps	4.0 Gbps	5
OUI	Aurora lane unit interval ^{1,2}	—	200	—	ps	5.0 Gbps	5

1. +/- 100 PPM.
2. The Aurora interface supports data rates of 2.0, 2.5, 3.0, 3.4, 4.0, and 5.0 Gbps.

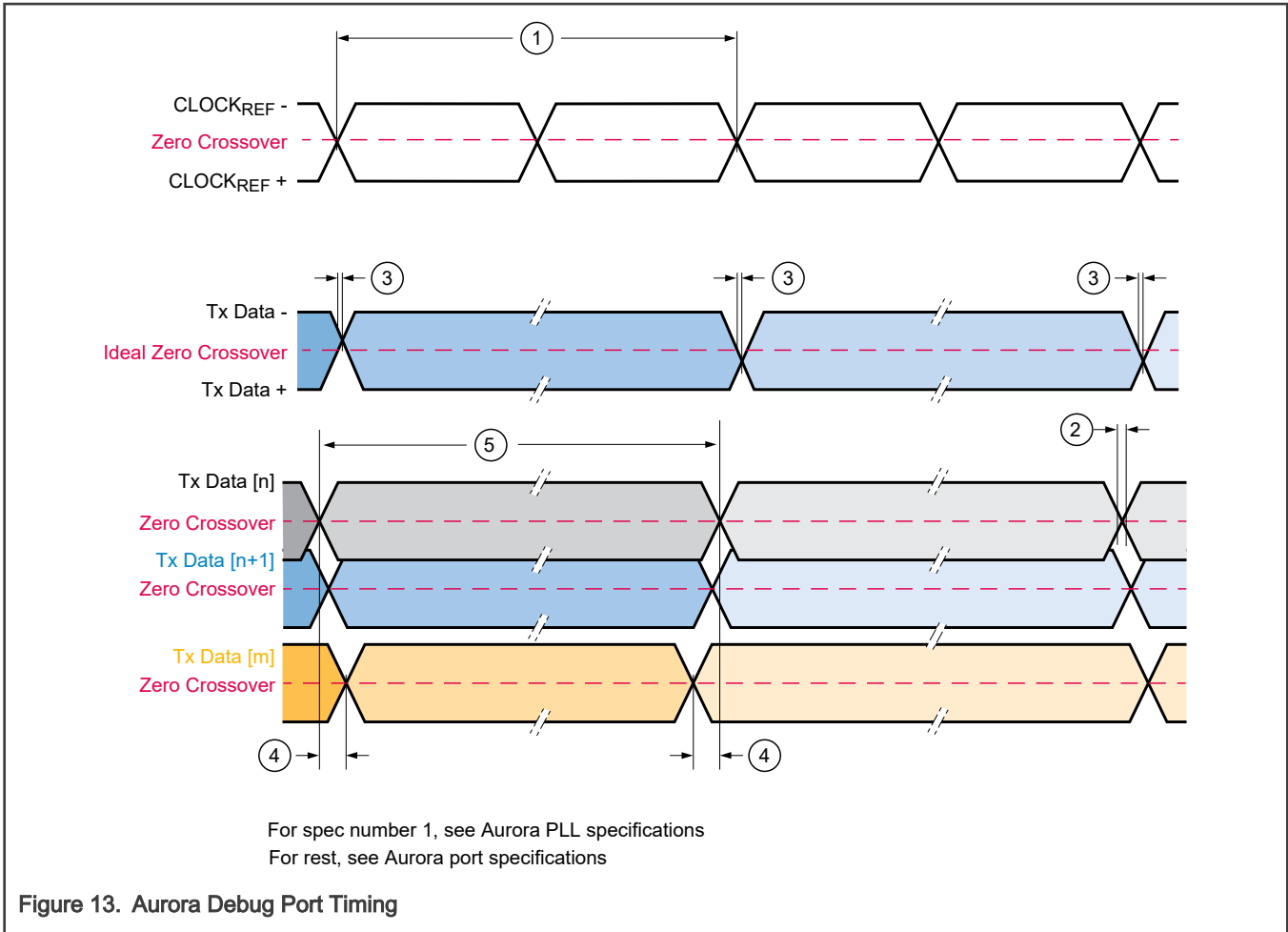

13.3 Aurora PLL

The following table gives the operating frequencies and characteristics of the Aurora PLL. The operating frequencies correspond to the supported Aurora data trace lane speed. The Aurora PLL works from an external 100MHz input reference clock, and achieves a maximum output frequency of 5GHz.

Table 15. Aurora PLL

Symbol	Description	Min	Typ	Max	Unit	Condition	Spec Number
fPLL_CLKIN	Aurora PLL Input Reference Clock Frequency ^{1, 2, 3}	—	100	—	MHz	—	—
fPLL_CLKIN_PFD	Aurora PLL Phase Detector Clock Frequency ⁴	—	100	—	MHz	—	—
Δf_{PLL_CLKIN}	Aurora PLL Input Reference Clock Duty Cycle ¹	40	—	60	%	—	—

Table continues on the next page...

Table 15. Aurora PLL (continued)

Symbol	Description	Min	Typ	Max	Unit	Condition	Spec Number
JRCDC	Reference clock period jitter	—	—	5	ps	RMS, 0.5MHz - 20MHz	—
fPLL_VCO	Aurora PLL VCO Frequency Range	3000	—	5000	MHz	—	—
fPLL_CLKOUT0	Aurora PLL Output Clock 0 Frequency Range ⁵	—	—	5000	MHz	5.0Gbps Aurora lane data rate, VCO frequency divided by 1	—
fPLL_CLKOUT0	Aurora PLL Output Clock 0 Frequency Range ⁵	—	—	4000	MHz	4.0Gbps Aurora lane data rate, VCO frequency divided by 1	—
fPLL_CLKOUT0	Aurora PLL Output Clock 0 Frequency Range ⁵	—	—	3400	MHz	3.4Gbps Aurora lane data rate, VCO frequency divided by 1	—
fPLL_CLKOUT0	Aurora PLL Output Clock 0 Frequency Range ⁵	—	—	3000	MHz	3.0Gbps Aurora lane data rate, VCO frequency divided by 1	—
fPLL_CLKOUT0	Aurora PLL Output Clock 0 Frequency Range ⁵	—	—	2500	MHz	2.5Gbps Aurora lane data rate, VCO frequency divided by 2.	—
fPLL_CLKOUT0	Aurora PLL Output Clock 0 Frequency Range ⁵	—	—	2000	MHz	2.0Gbps Aurora lane data rate, VCO frequency divided by 2.	—
fPLL_CLKOUT0	Aurora PLL Output Clock 0 Frequency Range	—	—	500	MHz	No tool connected - trace logic clock with FXOSC reference clock.	—
tLOCK	Aurora PLL Lock Time	—	—	150	us	—	—
PER_jitter	Aurora PLL Period Jitter	-21	—	21	ps	fPLL_CLKIN = 100MHz, VCO = 5GHz, fPLL_CLKOUT = 5GHz, 6-sigma	—
LT_jitter	Aurora PLL Long Term Jitter	-120	—	120	ps	Saturated, 6-sigma	—

1. Refer to the LVDS Pad specifications for additional Aurora PLL reference clock electrical specifications. Also see "Aurora Debug Port Timing" figure for fPLL_CLKIN as spec number 1.
2. 100MHz is the only input reference frequency supported for the Aurora PLL.
3. 40MHz is the only internal input reference frequency supported for the Aurora PLL.
4. It is Aurora PLL Input Reference Clock Frequency after pre-divider.
5. The Aurora PLL is only validated at the frequencies specified within this table - these frequencies correspond to the limited set of Aurora data lane rates that are supported for the device.

14 Power Management Controller (PMC)

14.1 PMC Bandgap

Table 16. PMC Bandgap

Symbol	Description	Min	Typ	Max	Unit	Condition	Spec Number
VBG_SCALED	Scaled version of bandgap reference voltage measured by SAR ADC ¹	1.127	1.150	1.173	V	Both bandgap and buffer are trimmed	—

1. ADC conversion error must be included when reading the bandgap reference voltage via the chip ADC.

15 Reset

15.1 Reset Duration

The durations specified "Reset Duration" table and the corresponding figures refer to standard reset sequences. A reset sequence is no longer standard when it is interrupted by another power-on or destructive reset event, in which case the reset sequence restarts from the beginning of the reset sequence corresponding to that event, and the total duration is the time already spent in reset plus the duration of the new sequence.

The diagrams in this section are not to scale.

Table 17. Reset Duration

Symbol	Description	Min	Typ	Max	Unit	Condition	Spec Number
TFR	Functional Reset Sequence Duration	—	—	545	us	FIRC_CLK, trimmed	—
TDR	Destructive Reset Sequence Duration	—	—	1370	us	FIRC_CLK, trimmed during destructive reset phase	—
POR	Power On Reset Sequence Duration	—	—	1500	us	FIRC_CLK, trimmed during destructive reset phase	—

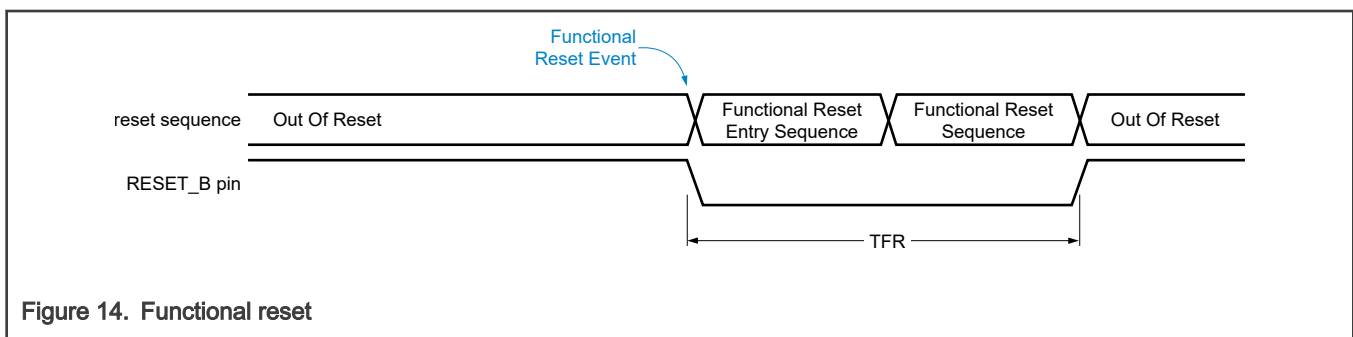
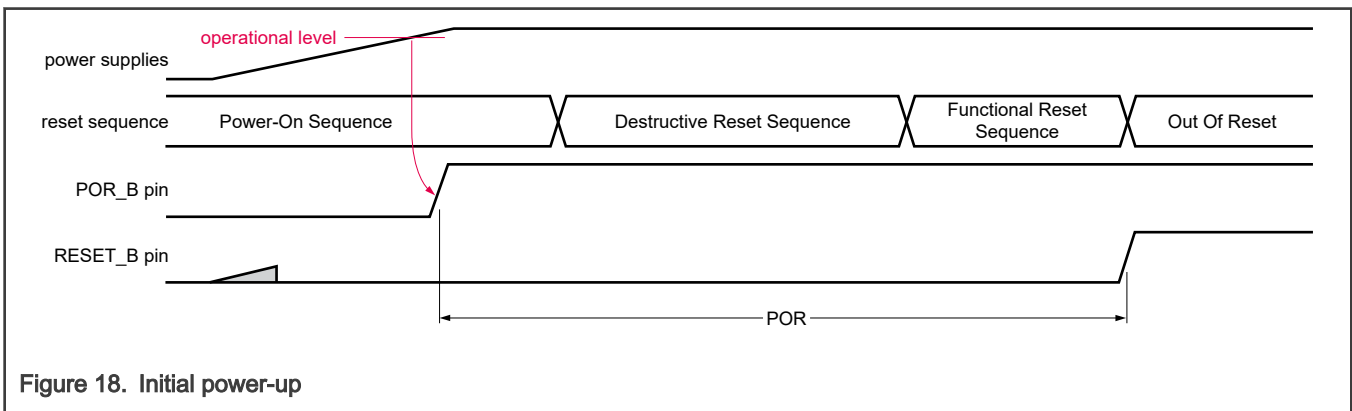
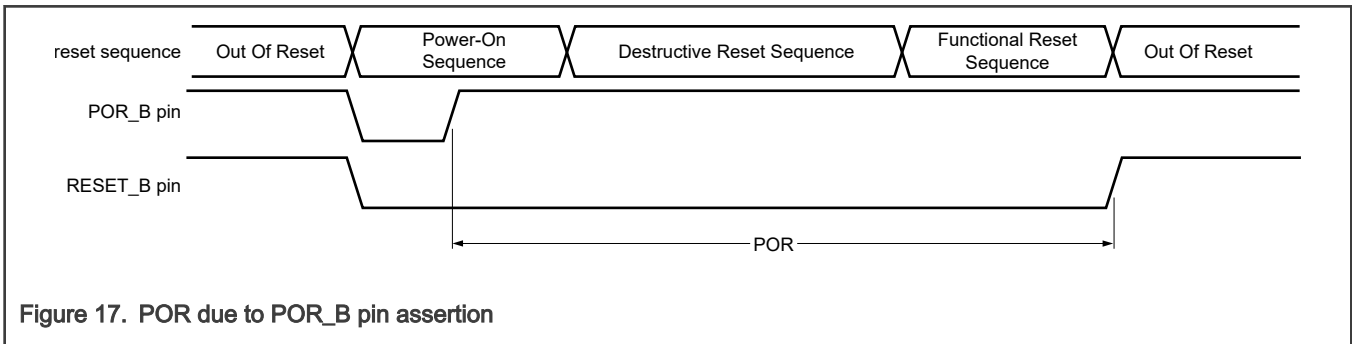
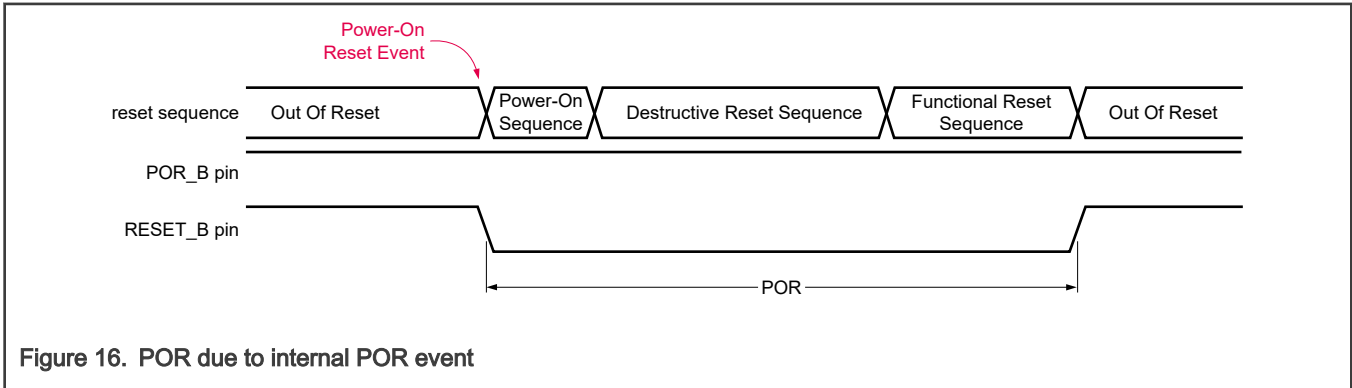
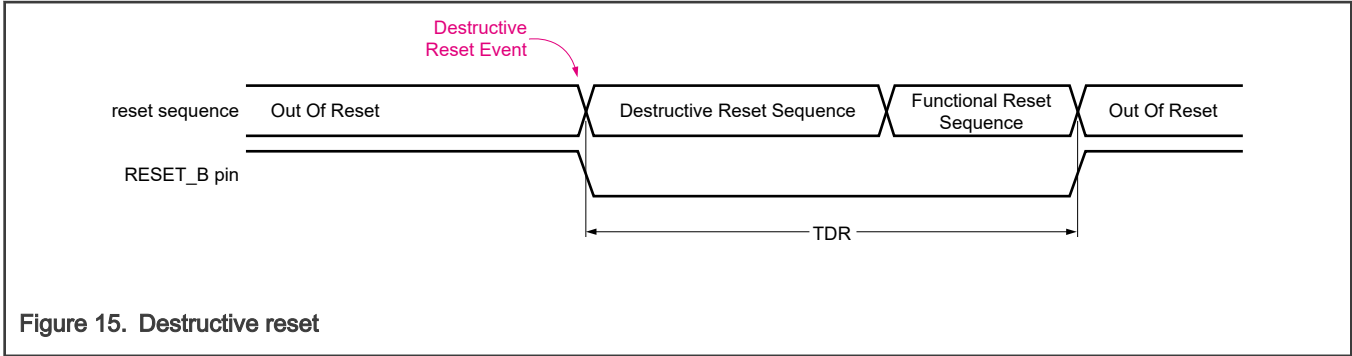

Figure 14. Functional reset



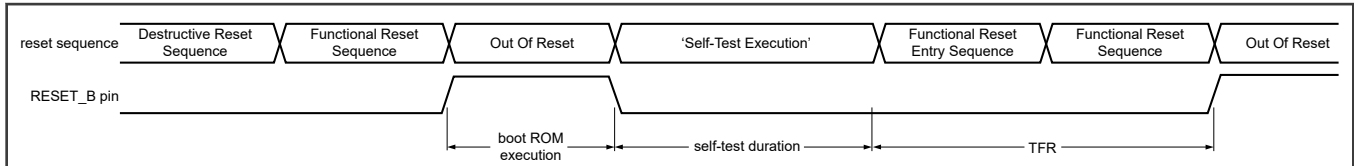

Figure 19. Start-up self-test

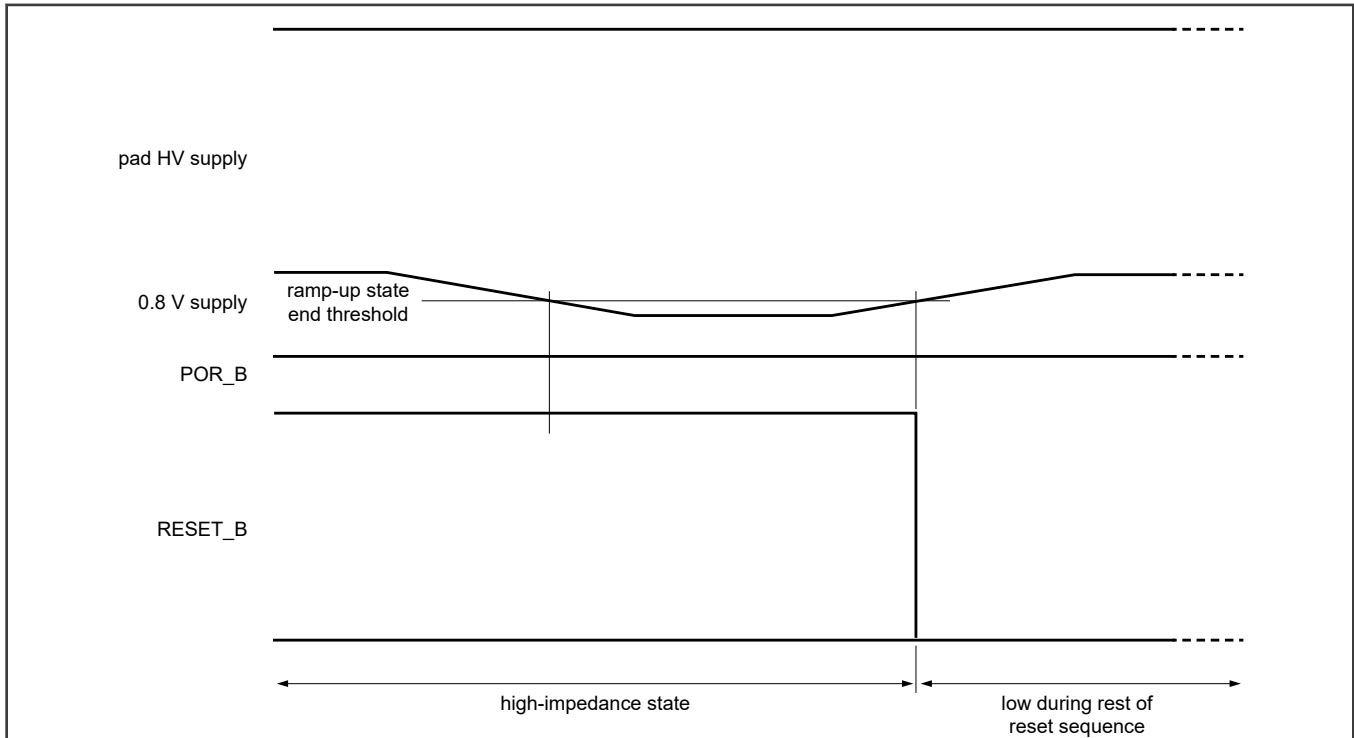
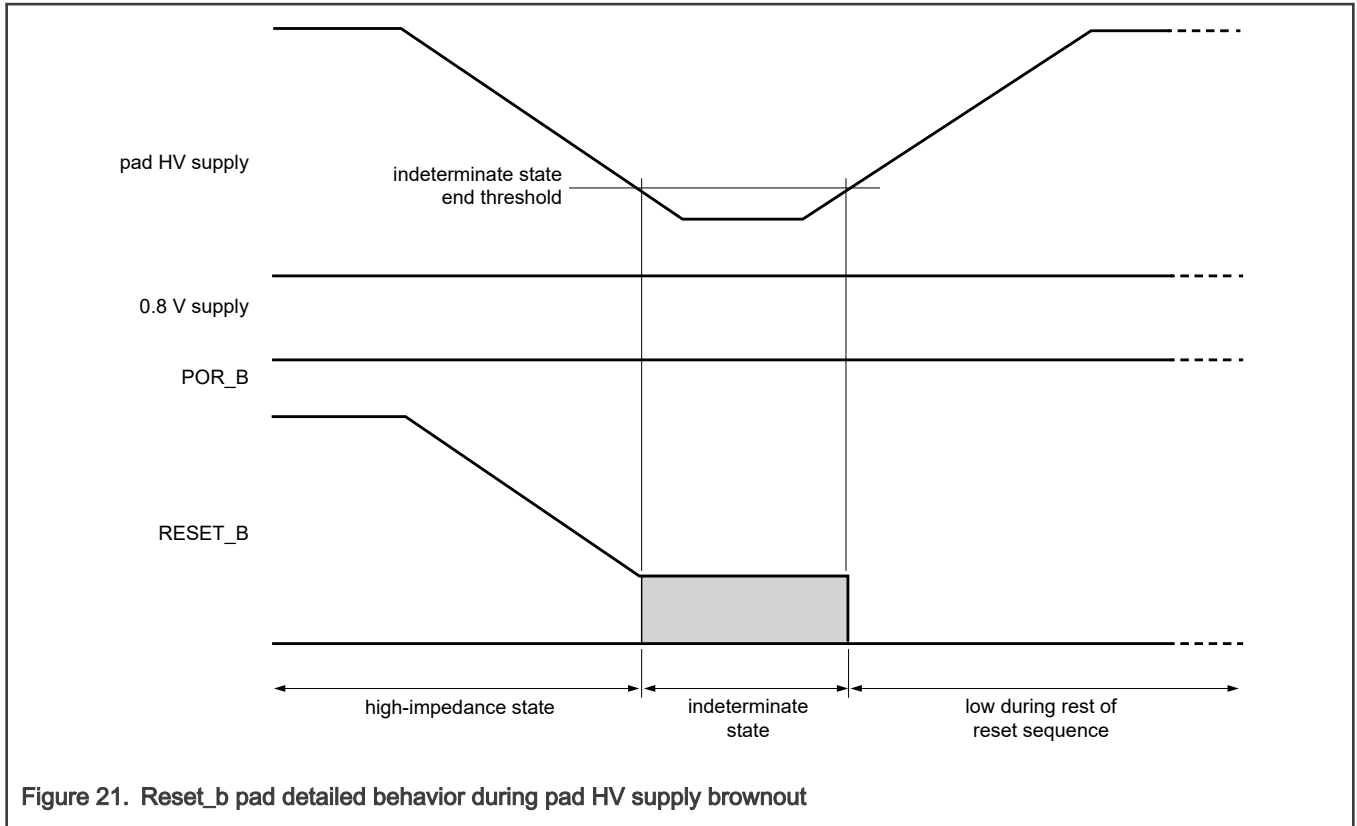
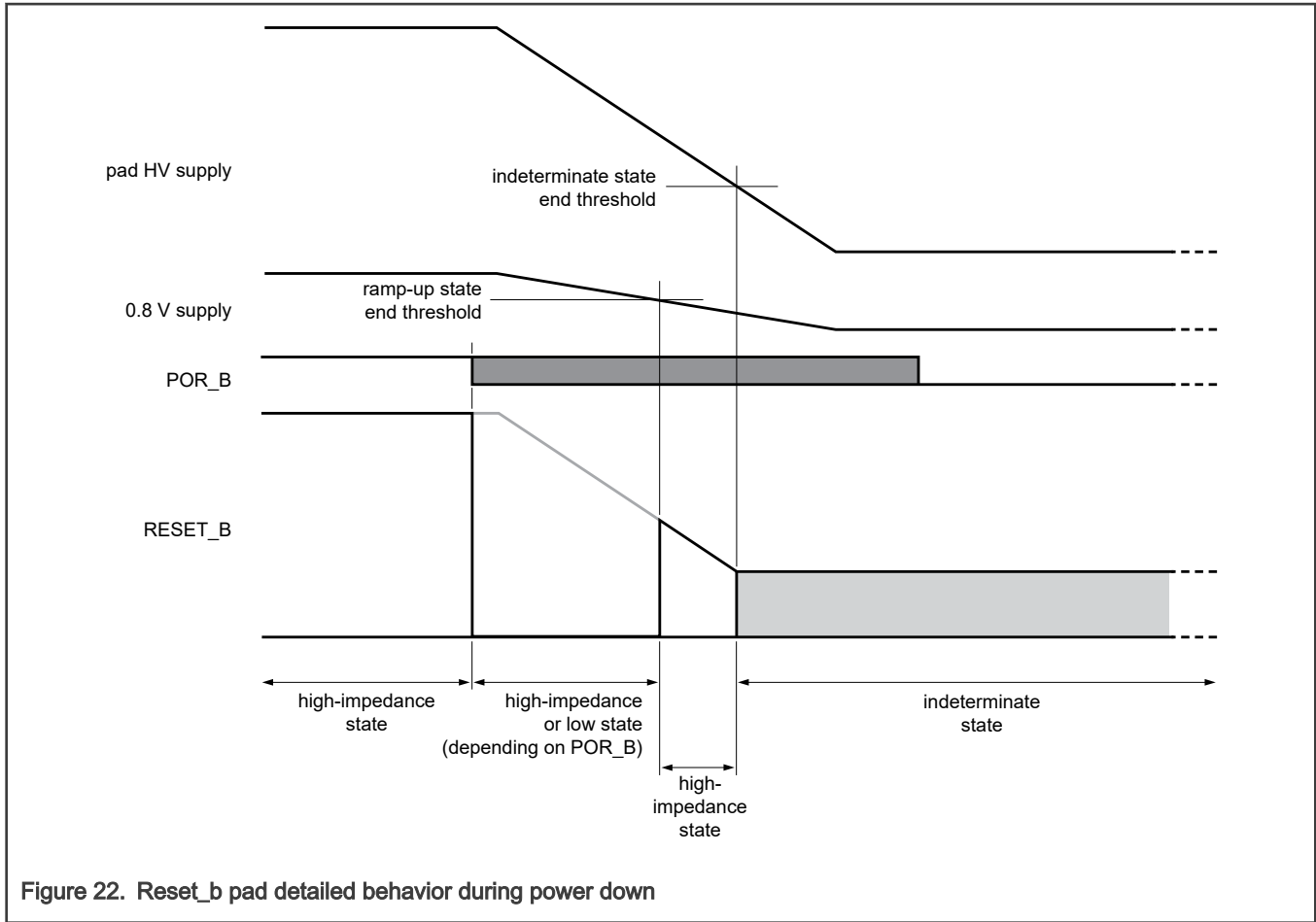

Figure 20. Reset_b pad detailed behavior during core supply brownout





15.2 Reset and Standby related pad electrical characteristics

The following table gives the characteristics of the POR_B, RESET_B, PMIC_STBY_MODE_B, and PMIC_VDD_OK pads. Values not explicitly listed in this table can be found in the 'GPIO Pads' section.

Table 18. Reset and Standby related pad electrical characteristics

Symbol	Description	Min	Typ	Max	Unit	Condition	Spec Number
ISLEW_POR_B	POR_B slew rate	30e-06	—	4	V/ns	—	—
ISLEW_RESET_B	RESET_B slew rate ¹	30e-06	—	4	V/ns	Noise on RESET_B <100mV peak-peak.	—
WISE_RESET_B	RESET_B pad indeterminate state end threshold	—	2.35	—	V	See RESET_B pad detailed behavior diagram below	—
VRSE_RESET_B	RESET_B pad ramp-up state end threshold	—	460	—	mV	See RESET_B pad detailed behavior diagram below	—
WF_RESET_B	RESET_B input filtered pulse	—	—	17	ns	—	—

Table continues on the next page...

Table 18. Reset and Standby related pad electrical characteristics (continued)

Symbol	Description	Min	Typ	Max	Unit	Condition	Spec Number
WNF_RESET_B	RESET_B input not filtered pulse	400	—	—	ns	—	—
MLP_POR_B	POR_B minimum low pulse	5	—	—	us	—	—
MLP_PMIC_VDD_OK	PMIC_VDD_OK minimum low pulse	36	—	—	us	during Standby mode entry	—
MHP_PMIC_VDD_OK	PMIC_VDD_OK minimum high pulse	36	—	—	us	during Standby mode exit	—

1. $ISLEW_RESET_B(\text{Min}) = \text{MAX}[30\text{e-}06, 0.002 * V_{\text{noise_p_p}} * F_{\text{noise}}]$, where $V_{\text{noise_p_p}}$ is peak-peak noise magnitude (in V) and F_{noise} is max noise frequency (in MHz).

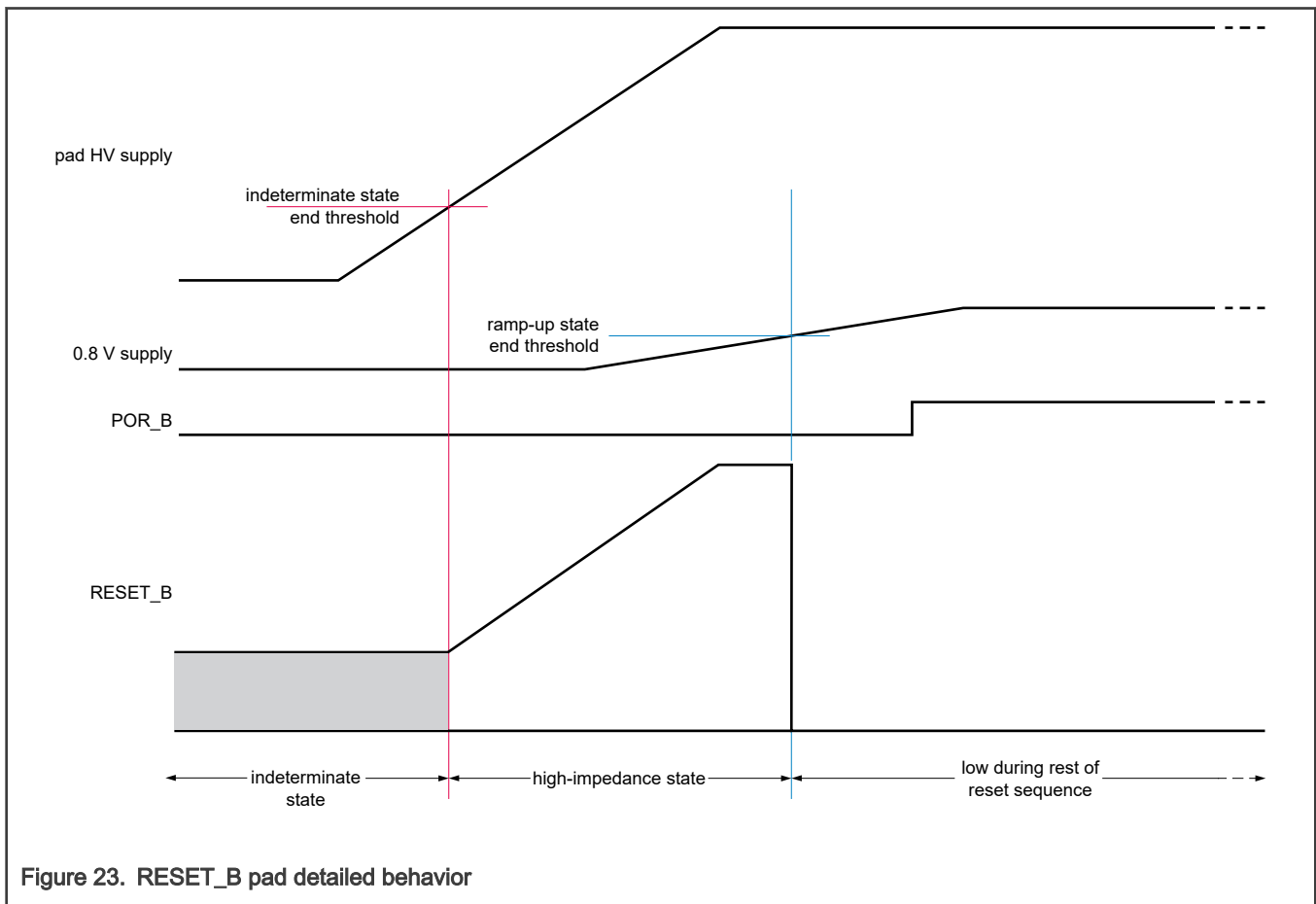

Figure 23. RESET_B pad detailed behavior

The RESET_B pad behavior described in the diagram and the related VRSE_RESET_B parameter spec also apply to the case of core VDD droop after power-up.

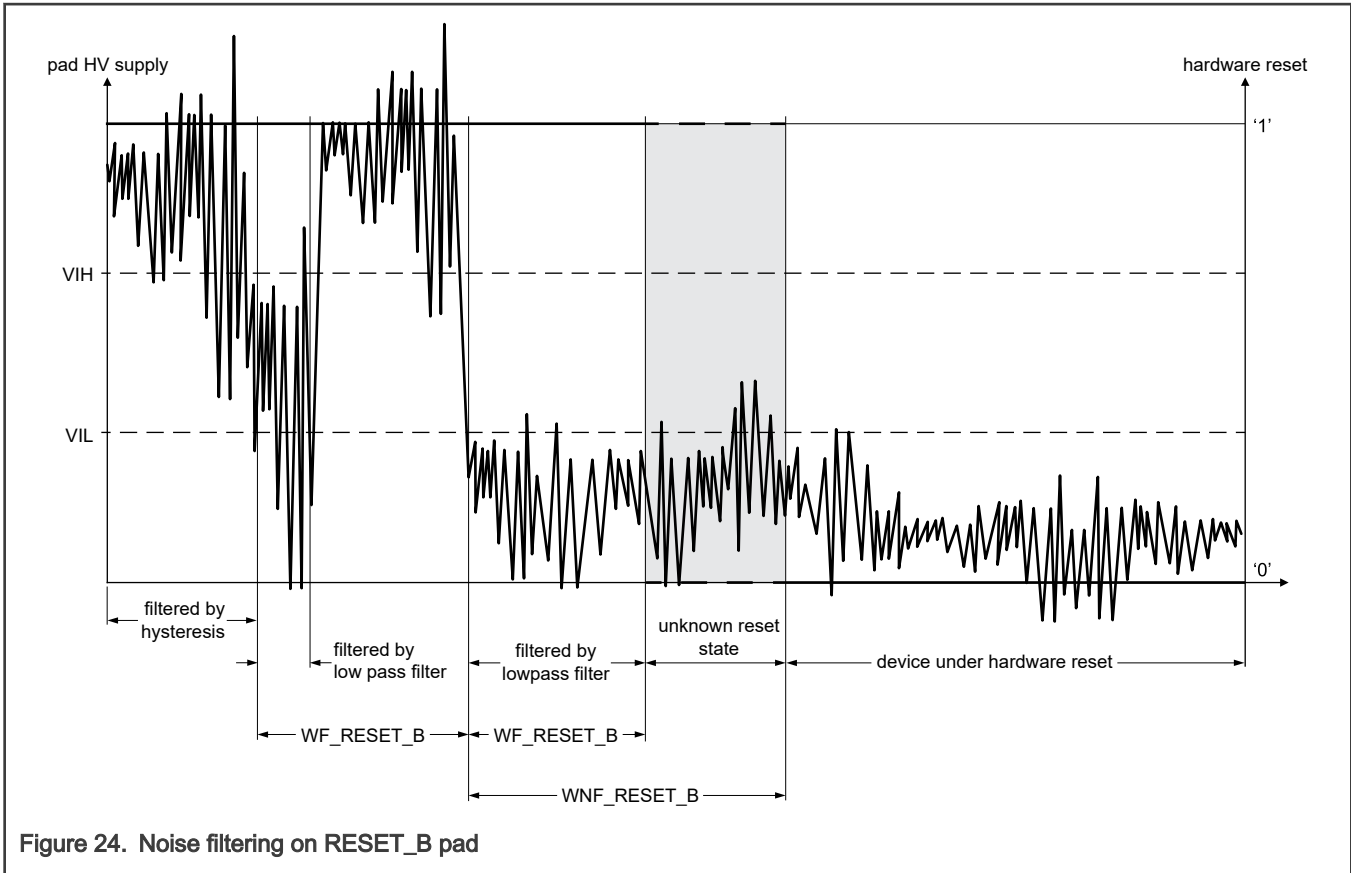

Figure 24. Noise filtering on RESET_B pad

During SoC power-up, the PMIC asserts the POR_B input before the SoC supplies are turned on and kept asserted until all SoC supplies have reached their operational levels (i.e., all the corresponding voltage monitors in the PMIC have been satisfied) and any required PMIC BIST has completed. See the 'Power Sequencing' section for details.

The PMIC asserts the POR_B input whenever one of its voltage detectors detects an SoC supply's voltage is outside its operational range (i.e., a corresponding PMIC LVD or HVD event occurs).

15.3 PMIC Standby Mode Entry / Exit Protocol

The PMIC_STBY_MODE_B output is:

1. asserted by the SoC when the power domains that are not needed during Standby mode are to be turned off
2. deasserted by the SoC when the power domains that are not needed during Standby mode are to be turned on

The PMIC_VDD_OK input is:

1. deasserted by the PMIC when the power domains that are not needed during Standby mode have been turned off
2. asserted by the PMIC when the power domains that are not needed during Standby mode have been turned on and have reached their operational levels (e.g., all the corresponding voltage monitors in the PMIC have been satisfied) and any required PMIC BIST has completed. See the "Power Sequencing" section for any exceptions.

This implies that the PMIC_VDD_OK input is asserted and deasserted together with the POR_B input during non-Standby modes. Deasserting PMIC_VDD_OK during non-Standby modes while not also asserting POR_B will cause the SoC to start a power-on reset sequence.

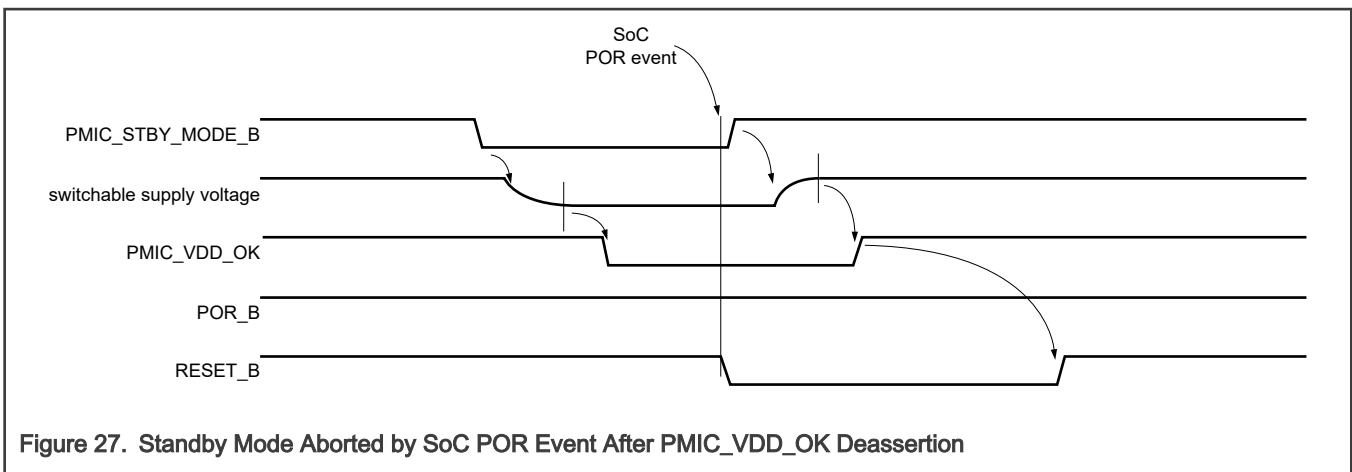
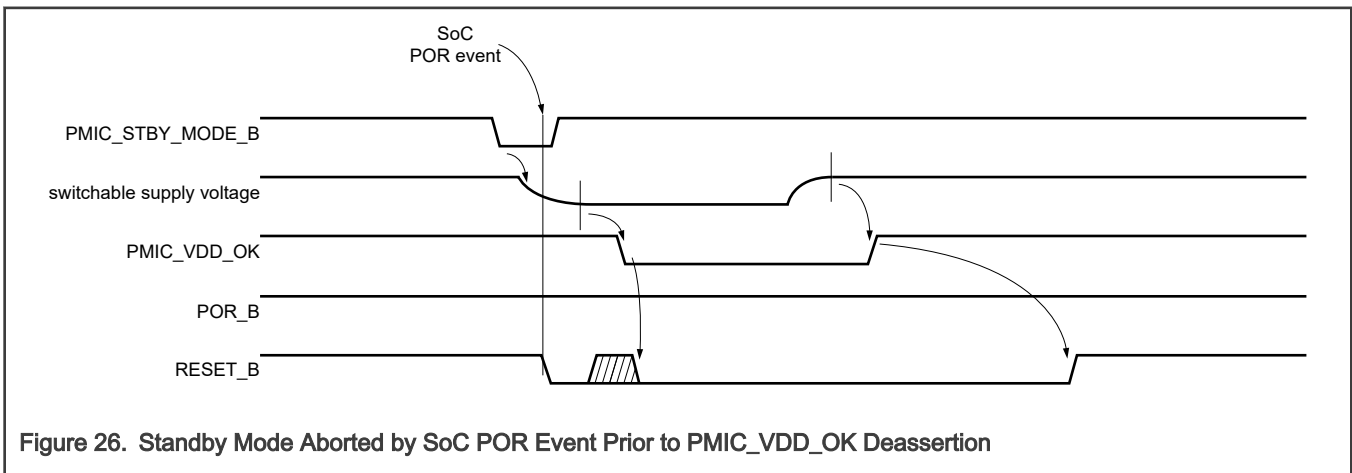
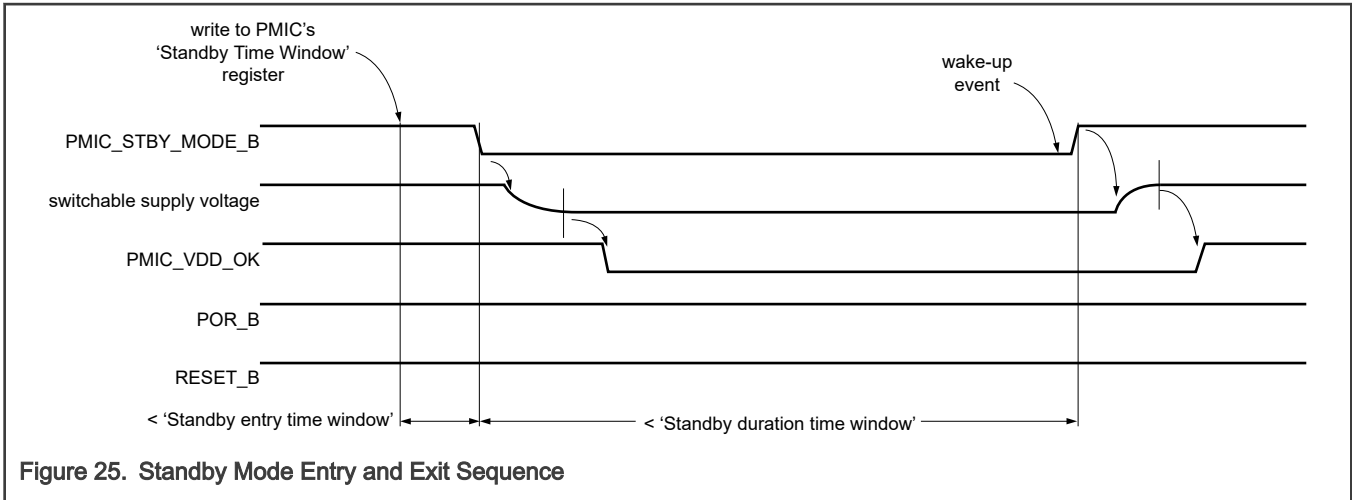

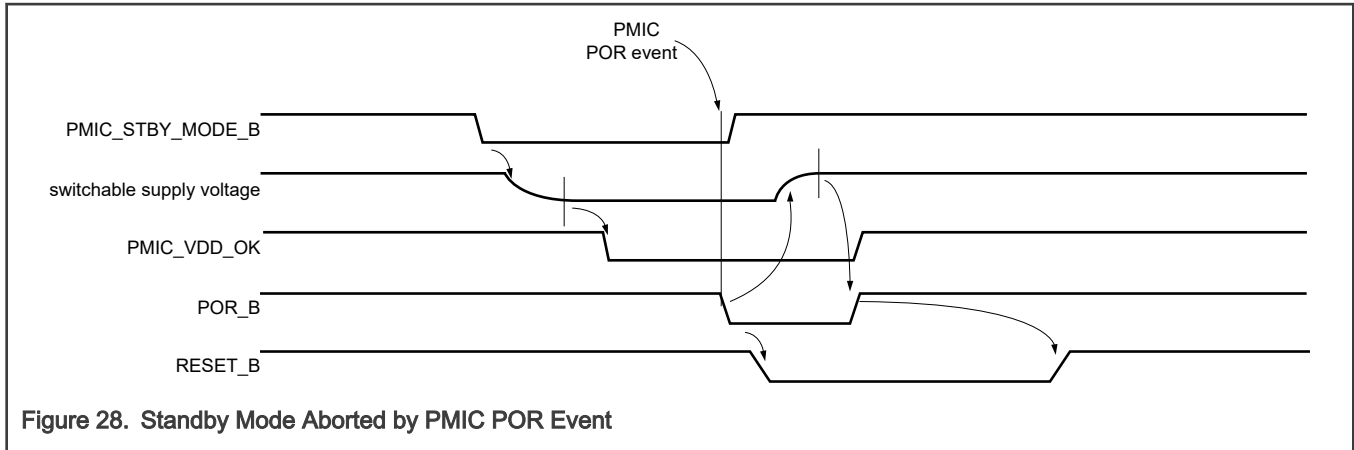

16 Peripheral specifications

16.1 Analog Modules

16.1.1 SAR ADC

ADC performance specifications are only guaranteed when the injection current limits in the operating conditions table of this electrical specification are met.

Although functionally supported on devices with 2 ADCs, ADC performance specifications are not guaranteed for shared channels between the 2 ADCs if the input channel is sampled or converted simultaneously by both ADCs. For best performance in this case, the external capacitance at the input pin and reference pin should be maximized.

Table 19. SAR ADC

Symbol	Description	Min	Typ	Max	Unit	Condition	Spec Number
VAD_INPUT	ADC Input Voltage ¹	VSS_AD C	—	VDD_AD C	V	on or off channels	—
fAD_CK	ADC Clock Frequency	20	—	80	MHz	—	—
tSAMPLE	ADC Input Sampling Time ²	275	—	—	ns	—	—
tCONV	ADC Total Conversion Time ³	1	—	—	us	—	—
tRECOVERY	ADC Initialization Time from power-down	—	—	1	us	—	—
CAD_INPUT	ADC Input Capacitance	—	—	7	pF	ADC component plus pad capacitance (~2pF)	—
RAD_INPUT	ADC Input Series Resistance	—	—	1.25	kΩ	—	—
OFS	ADC Offset Error ⁴	-6	—	6	LSB	after calibration	—

Table continues on the next page...

Table 19. SAR ADC (continued)

Symbol	Description	Min	Typ	Max	Unit	Condition	Spec Number
GNE	ADC Gain Error (full scale) ⁴	-6	—	6	LSB	after calibration	—
DNL	ADC Differential Non-linearity ^{4, 5, 6}	-1	—	2	LSB	after calibration	—
INL	ADC Integral Non-linearity ^{4, 6}	-3	—	3	LSB	after calibration	—
TUE	ADC Total Unadjusted Error ^{4, 6}	-8	—	8	LSB	after calibration	—
SNR	Signal-to-Noise Ratio ⁴	—	65	—	dBFS	input signal frequency <= 50KHz	—
THD	Total Harmonic Distortion ⁴	—	72	—	dBFS	Input signal frequency <= 50KHz.	—
IAD_LKG	ADC Input Leakage Current ⁷	-1	—	1	uA	TJ = 125C, Dedicated input channel, channel selection switch open	—
IAD_LKG	ADC Input Leakage Current ⁷	-2	—	2	uA	TJ = 125C, Shared channel, channel selection switch open	—
CP1	ADC input pin capacitance 1	—	—	4	pF	—	—
CP2	ADC input pin capacitance 2	—	—	0.5	pF	—	—
CS	ADC input sampling capacitance	—	—	4	pF	—	—
RSW1	Internal resistance of analog source	—	—	600	ohm	—	—
RAD	Internal resistance of analog source	—	—	150	ohm	—	—

1. The reduced limits for VAD_INPUT in this table are recommended for normal operation.
2. During the sample time the input capacitance CS can be charged/discharged by the external source. The internal resistance of the analog source must allow the capacitance to reach its final voltage level within t_{sample}. After the end of the sample time t_{sample}, changes of the analog input voltage have no effect on the conversion result. Values for the sample clock t_{sample} depend on programming.
3. 1Msps is the ADC output rate and includes both sampling and analog to digital conversion.
4. ADC performance specifications are guaranteed when calibration uses maximum averaging i.e. when AVGEN = 1 and NRSMPL = 3.
5. During calibration, the ADC determines its (positive or negative) offset value and stores the result in an internal register. During each conversion, the offset value is subtracted from the raw result to compensate the individual ADC offset. Since the ADC cannot generate negative numbers, a negative calibration offset results in a minimum output code between 0 and 6. A positive calibration offset does not impact the max. code output of 4095. Calibration fails if it determines an offset larger than +/- 6 LSB.
6. This specification is taken with averaging through post process ADC data.
7. The maximum and minimum leakage current values are reached when Vin=VREF and Vin=0, respectively.

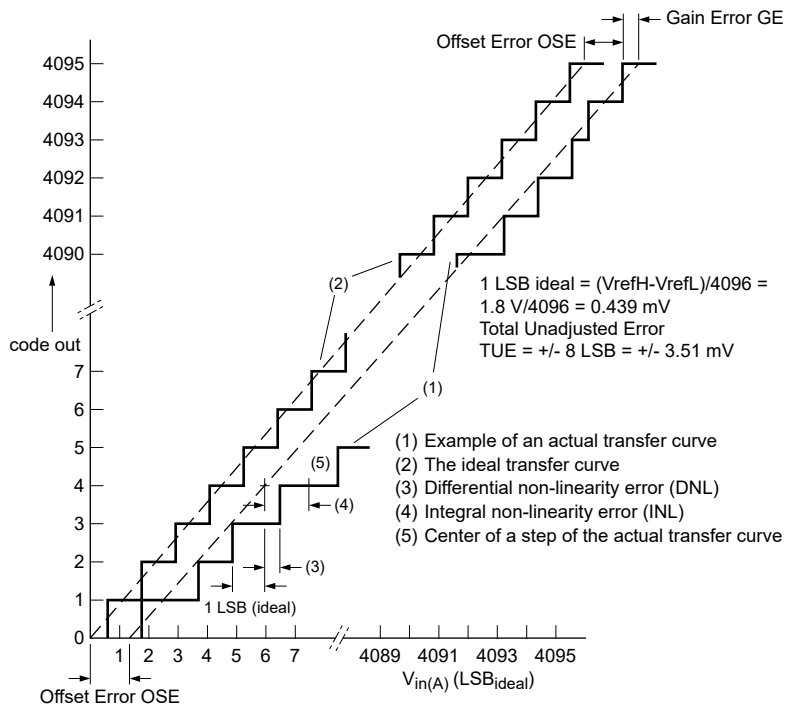

Figure 29. SAR ADC Specification Characteristics

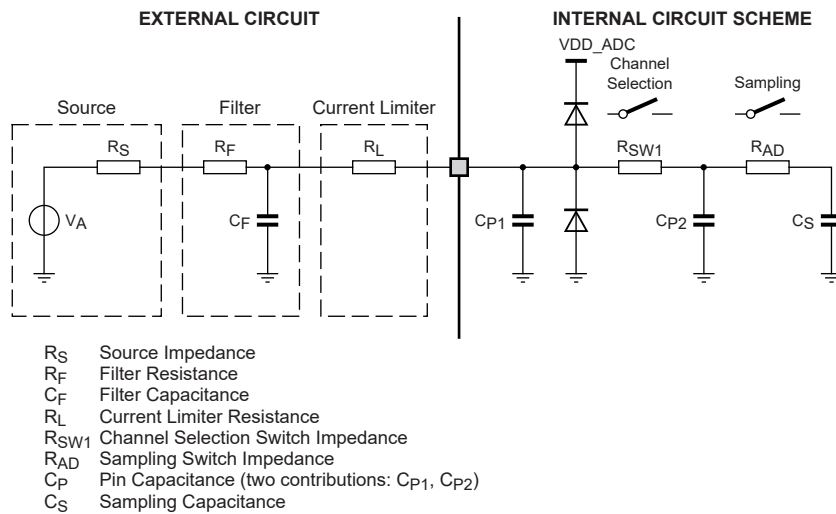

Figure 30. SAR ADC Input Circuit

16.1.2 Temperature Monitoring Unit (TMU)

The table below gives the specification for the Temperature Monitoring Unit (TMU). Specifications apply to all remote temperature sensors connected to the TMU on the device.

Table 20. Temperature Monitoring Unit (TMU)

Symbol	Description	Min	Typ	Max	Unit	Condition	Spec Number
TRANGE	Temperature monitoring range ¹	-45	—	130	C	—	—
TERR	Temperature sensor error	-8	—	8	C	TRANGE = -40C to 84C	—
TERR	Temperature sensor error	-5	—	5	C	TRANGE = 85C to 110C	—
TERR	Temperature sensor error	-3	—	3	C	TRANGE = 111C to 125C	—

1. Accuracy outside of operating range (-40 to 125) is not guaranteed.

16.1.3 Glitch Filter

Table 21. Glitch Filter

Symbol	Description	Min	Typ	Max	Unit	Condition	Spec Number
TFILT	Glitch filter max filtered pulse width ^{1, 2, 3, 4}	—	—	17	ns	—	—
TUNFILT	Glitch filter min unfiltered pulse width ^{2, 3, 4, 5}	400	—	—	ns	—	—

1. Pulses shorter than defined by the maximum value are guaranteed to be filtered (not passed).
2. Pulses in between the max filtered and min unfiltered may or may not be passed through.
3. See the device reference manual for which package pins include glitch filters on the pin input.
4. An input signal pulse is defined by the duration between the input signal's crossing of a V_{il}/V_{ih} threshold voltage level, and the next crossing of the opposite level.
5. Pulses larger than defined by the minimum value are guaranteed to not be filtered (passed).

16.1.4 IRQ

The following table gives the input specifications for the external interrupt pins.

tCYC refers to FIRC_CLK.

Table 22. IRQ

Symbol	Description	Min	Typ	Max	Unit	Condition	Spec Number
tIPWL	IRQ pulse width low	4	—	—	tCYC	MAXCNT = 3	1
tIPWH	IRQ pulse width high	4	—	—	tCYC	MAXCNT = 3	2

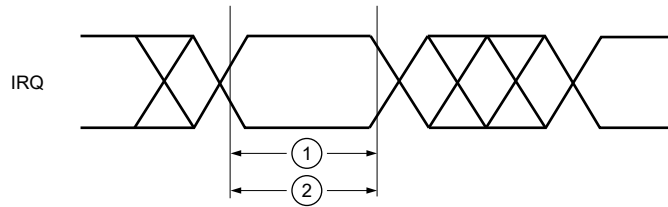

Figure 31. External Interrupt Timing (IRQ)

16.2 Clock and PLL Interfaces

16.2.1 DFS

The following table specifies the output frequency ranges and characteristics of the Digital Frequency Synthesizer (DFS).

Table 23. DFS

Symbol	Description	Min	Typ	Max	Unit	Condition	Spec Number
fDFS_CORE_CLK1	Core DFS Output Clock 1 Frequency	40	—	800	MHz	CORE_DFS1	—
fDFS_PER_CLK1	Peripheral DFS Output Clock 1 Frequency	532	—	800	MHz	PERIPH_DFS1	—
fDFS_PER_CLK2	Peripheral DFS Output Clock 2 Frequency	40	—	628	MHz	PERIPH_DFS2	—
fDFS_PER_CLK3	Peripheral DFS Output Clock 3 Frequency	416	—	800	MHz	PERIPH_DFS3	—
fDFS_CLKIN	DFS Input Clock Frequency	1300	—	2622	MHz	—	—
PER_jitter	DFS Period Jitter ^{1, 2}	-30	—	30	ps	Even MFN	—
PER_jitter	DFS Period Jitter ^{1, 2}	-45	—	45	ps	fDFS_CLKIN = 2000 MHz, Odd MFN	—
PER_Jitter	DFS Period Jitter ^{1, 2}	-30	—	30	ps	fDFS_CLKIN = 2622 MHz, Odd MFN	—
PER_jitter	DFS Period Jitter ^{1, 2}	-60	—	60	ps	fDFS_CLKIN = 1300 MHz, Odd MFN	—

- For SoC clocks that are further divided down from the DFS output clock, the jitter is multiplied by a factor of \sqrt{N} , where N is the ratio of the DFS output clock and destination clock periods.
- Jitter value does not apply when the DFS clock is output on an external pin. In this case, the rise and fall time variations in the I/O pad are orders of magnitude more than the DFS and SoC mux jitter contributions.

Peripheral DFS output clock min jitter= $\text{Min}(\text{PER_jitter}(\text{PLL})) \times (\text{sqrt}(\text{N})) + \text{Min}(\text{PER_jitter}(\text{DFS}))$. Peripheral DFS output clock max jitter= $\text{Max}(\text{PER_jitter}(\text{PLL})) \times (\text{sqrt}(\text{N})) + \text{Max}(\text{PER_jitter}(\text{DFS}))$. Where N is the DFS division factor. All jitter numbers are in ps.

16.2.2 FIRC

Table 24. FIRC

Symbol	Description	Min	Typ	Max	Unit	Condition	Spec Number
fFIRC	FIRC Target Frequency	—	48	—	MHz	—	—
δfVAR	FIRC Frequency Variation ¹	-5	—	5	%	Trimmed	—
TSTART	Startup Time	—	10	20	us	After valid supply level reached	—

1. δfVAR defines how much the output frequency can shift over the specified temperature and voltage ranges of the device after initial factory trim.

16.2.3 SIRC

Table 25. SIRC

Symbol	Description	Min	Typ	Max	Unit	Condition	Spec Number
fSIRC	SIRC Target Frequency Trimmed	—	32	—	KHz	Trimmed	—
PTA	SIRC Trimming Resolution ¹	-1	—	1	%	Trimmed 32KHz, 25C, 0.8V Core	—
δfVAR	SIRC Frequency Variation ²	-5	—	5	%	Frequency variation across voltage and temperature range after trimming.	—
TSTART	SIRC Startup Time	—	—	50	us	—	—

1. PTA defines how close the output frequency is to target after the initial factory trim.
 2. δfVAR defines how much the output frequency can shift over the specified temperature and voltage ranges of the device.

16.2.4 FXOSC

Table 26. FXOSC

Symbol	Description	Min	Typ	Max	Unit	Condition	Spec Number
fXTAL	Input Frequency Range ^{1, 2}	20	—	40	MHz	Crystal mode	—
TCST	Crystal Startup Time	—	—	2	ms	Crystal mode	—
fBYP_SE	FXOSC Bypass Frequency ³	—	40	—	MHz	single-ended bypass mode	—
VIH_EXTAL	EXTAL Input High Level ⁴	VCM_SE + 0.3	—	VDD_FX OSC	V	Single-ended bypass mode	—

Table continues on the next page...

Table 26. FXOSC (continued)

Symbol	Description	Min	Typ	Max	Unit	Condition	Spec Number
VIL_EXTAL	EXTAL Input Low Level ⁴	0	—	VCM_SE - 0.3	V	Single-ended bypass mode	—
CLOAD	XTAL/EXTAL pin load capacitance ⁵	—	8	—	pF	Crystal mode	—
CS_XTAL	XTAL/EXTAL pin on-chip stray capacitance ⁵	—	—	3	pF	—	—
VCM_SE	Common Mode Voltage for Single ended Bypass	—	VDD_FX OSC / 2	—	mV	—	—
Leakage_injection	EXTAL injection current	-50	—	100	nA	Mean current flowing into EXTAL in crystal mode	—
Leakage_extal	External Leakage on EXTAL Pin	-20	—	20	nA	Bypass mode, 0.5V	—
EXTAL_AMP	EXTAL_amplitude (p k-pk)	300	—	900	mV	Crystal mode	—
LT_Jitter	Long term jitter	-120	—	120	ps	gm_sel=1111 with 40MHz crystal (NX5032GA and NX3225GA)	—

1. Recommended crystal frequencies are 20MHz, 24MHz, and 40MHz.
2. All specifications only valid for this frequency range if the correct FXOSC transconductance setting is used.
3. The input clock must be 40 MHz nominal frequency.
4. The input clock signal should be symmetric around common mode voltage.
5. Account for on-chip stray capacitance (CS_XTAL) and PCB capacitance in the total XTAL/EXTAL pin load capacitance. CS_XTAL don't include miller capacitance.

In crystal mode NX5032GA crystal at 20 MHz has a load cap of 8 pF and configure gm_sel[3:0]=4'b0100 and NX3225GA crystal has a load cap of 8 pF and configure gm_sel[3:0]=4'b100.

In crystal mode NX5032GA crystal at 24 MHz has a load cap of 8 pF and configure gm_sel[3:0]=4'b0101 and NX3225GA has a load cap of 8 pF and configure gm_sel[3:0]=4'b0110.

In crystal mode NX5032GA and NX3225GA crystal at 40 MHz (ALC enable) has a load cap of 8 pF and configure gm_sel[3:0]=4'b1111.

In ALC disable mode the minimum crystal drive level should be greater than 500uW.

Duty cycle of the FXOSC clock when output on either the single-ended or LVDS CLKOUT pins is given in the I/O pad specifications.

See Hardware design guide for the recommended circuit for each mode.

RGMII specifications require clock source to have tolerance of +/- 50ppm. When using this mode, the crystal selected for system clock (FXOSC) should adhere to this specification.

16.2.5 PLL

The following table gives the operating frequencies and characteristics of the PLL, and applies to instances on the device. Actual operating frequencies for the device are constrained to the values given below.

PLL refers to the Core, Peripheral, Accelerator, and DDR reference PLLs on the device.

Spread spectrum clock modulation is only available on the Core, Accelerator and DDR reference PLLs.

Table 27. PLL

Symbol	Description	Min	Typ	Max	Unit	Condition	Spec Number
fPLL_CLKIN	PLL Input Clock Frequency ¹	20	—	100	MHz	Before PLL input divider.	—
fPLL_CLKIN_PFD	PLL Phase Detector Clock Frequency ²	20	—	40	MHz	After PLL input divider.	—
fPLL_CORE_VCO	Core PLL VCO Frequency Range ^{3, 4, 5, 6}	1300	—	2622	MHz	without center-spread SSCG enabled	—
fPLL_CORE_PHI0	Core PLL PHI0 Frequency ⁵	—	—	1311	MHz	CORE_PLL_PHI0, without center-spread SSCG enabled	—
fPLL_PER_VCO	Peripheral PLL VCO Frequency Range	1300	—	2000	MHz	—	—
fPLL_PER_PHI0	Peripheral PLL PHI0 Frequency	100	—	125	MHz	PERIPH_PLL_PHI0	—
fPLL_PER_PHI1	Peripheral PLL PHI1 Frequency	—	—	80	MHz	PERIPH_PLL_PHI1	—
fPLL_PER_PHI2	Peripheral PLL PHI2 Frequency	40	—	80	MHz	PERIPH_PLL_PHI2	—
fPLL_PER_PHI3	Peripheral PLL PHI3 Frequency	—	—	133	MHz	PERIPH_PLL_PHI3	—
fPLL_PER_PHI4	Peripheral PLL PHI4 Frequency	—	—	200	MHz	PERIPH_PLL_PHI4	—
fPLL_PER_PHI5	Peripheral PLL PHI5 Frequency	—	—	125	MHz	PERIPH_PLL_PHI5	—
fPLL_PER_PHI7	Peripheral PLL PHI7 Frequency	—	—	100	MHz	PERIPH_PLL_PHI7	—
fPLL_ACCEL_VCO	Accelerator PLL VCO Frequency Range ^{5, 6}	1300	—	2400	MHz	without center-spread SSCG enabled	—
fPLL_ACCEL_PHI1	Accelerator PLL PHI1 Frequency ⁵	—	—	600	MHz	ACCEL_PHI1, without center-spread SSCG enabled	—

Table continues on the next page...

Table 27. PLL (continued)

Symbol	Description	Min	Typ	Max	Unit	Condition	Spec Number
fPLL_DDR_VCO	DDR PLL VCO Frequency Range ^{5, 6, 7}	1300	—	1600	MHz	without center-spread SSCG enabled	—
fPLL_DDR_PHI0	DDR PLL PHI0 Frequency ^{5, 8}	800	—	800	MHz	DDR_CLK (3200 MT/s), without center-spread SSCG enabled	—
fPLL_DDR_PHI0	DDR PLL PHI0 Frequency ⁸	758	—	758	MHz	DDR_CLK (3032 MT/s)	—
fPLL_DDR_PHI0	DDR PLL PHI0 Frequency ⁸	666.5	—	666.5	MHz	DDR_CLK (2666 MT/s)	—
fPLL_DDR_PHI0	DDR PLL PHI0 Frequency ⁸	533.3	—	533.3	MHz	DDR_CLK (2133 MT/s)	—
fPLL_DDR_PHI0	DDR PLL PHI0 Frequency ⁸	466.6	—	466.6	MHz	DDR_CLK (1866 MT/s)	—
fPLL_DDR_PHI0	DDR PLL PHI0 Frequency ⁸	400	—	400	MHz	DDR_CLK (1600 MT/s)	—
tLOCK	System PLL Lock Time	—	—	100	us	—	—
PER_jitter	System PLL Period Jitter ^{9, 10, 11, 12}	-23	—	23	ps	fPLL_CLKIN = 40MHz, fVCO = 2GHz, 6-sigma, SSCG & Frac mode disabled	—
LT_jitter	System PLL Long Term Jitter ^{10, 12, 13}	-120	—	120	ps	Saturated, 6-sigma	—
fPLL_MOD	Spread Spectrum Clock Modulation Frequency ⁷	30	—	64	KHz	—	—

1. This refers to spec number 1 which is shown in the figure in Aurora port specifications
2. This specification is PLL input reference clock frequency after pre-divider.
3. Duty cycle of the system PLL clock when output on an external pin is given in the I/O pad specifications.
4. The frequencies are the nominal frequencies (i.e., what the PLL's VCO is configured to).
5. The max frequency in case of center-spread SSCG enabled for a modulation depth can be calculated as: Max frequency(with center-spread SSCG disabled) – (Modulation Depth(in %)/(2*100))* Max frequency (with center-spread SSCG disabled). For details, see section “Frequency modulation programming” in reference manual.
6. Same min frequency value applies for center-spread SSCG enabled as provided for center-spread SSCG disabled.
7. DDR PLL allows center-spread SSCG at fPLL_MOD 32KHz @2% MD (modulation depth) and fPLL_MOD 64KHz @ 1% MD
8. The DDR PHY internally multiplies the PLL_DDR_PHI0 by factor of two.
9. For chip clocks that are further divided down from the PLL output clock, the jitter is multiplied by a factor of SQRT(N), where N is the ratio of the PLL output clock and destination clock periods.
10. Jitter value does not apply when a PLL clock is output on an external pin. In this case, the rise and fall time variations in the I/O pad are orders of magnitude more than the PLL and SoC mux jitter contributions.
11. Jitter is dependent on the period of the PLL output clock, and the division ratio of the clock at the destination module.
12. Jitter is dependent on supply noise. Specified jitter values are valid for the FXOSC reference clock input only - not valid for FIRC reference clock input.
13. This specification is valid when all clock sources are stable.

NOTE

fPLL_DDR_PHI0 frequencies and data rate mentioned in this table are for LPDDR4. DDR3L frequencies and data rates are half of the LPDDR4.

16.3 Communication modules

16.3.1 SPI

Table 28. SPI

Symbol	Description	Min	Typ	Max	Unit	Condition	Spec Number
tSCK	SPI cycle time ^{1,2}	40	—	10000	ns	Master, MTFE=0	1
tSCK	SPI cycle time ¹	25	—	10000	ns	Master, MTFE=1	1
tSCK	SPI cycle time ^{1,3}	16.67	—	10000	ns	Slave Receive Mode	1
tSCK	SPI cycle time ¹	40	—	10000	ns	Slave Transmit Mode	1
tCSC	PCS to SCK delay ⁴	20	—	10000	ns	—	2
tASC	After SCK delay ⁵	20	—	10000	ns	—	3
tSDC	SCK duty cycle	40	—	60	%	—	4
tA	Slave access time	—	—	40	ns	SS active to SOUT valid	5
tDIS	Slave SOUT disable time	—	—	15	ns	SS inactive to SOUT hi-z or invalid	6
tPCSC	PCSx to PCSS time	13	—	—	ns	—	7
tPASC	PCSS to PCSx time	13	—	—	ns	—	8
tSUI	Input data setup time ^{6,7}	15	—	—	ns	Master, MTFE=0	9
tSUI	Input data setup time ^{6,8}	15 - N * ipg_clk_d spi_perio d	—	—	ns	Master, MTFE=1, CPHA=0, SMPL_PTR = 1	9
tSUI	Input data setup time ⁶	15	—	—	ns	Master, MTFE=1, CPHA=1, SMPL_PTR = 1	9
tSUI	Input data setup time ⁶	2	—	—	ns	Slave Receive Mode	9
tHI	Input data hold time ⁶	0	—	—	ns	Master, MTFE=0	10
tHI	Input data hold time ⁶	0 + N * ipg_clk_d spi_perio d	—	—	ns	Master, MTFE=1, CPHA=0, SMPL_PTR = 1	10

Table continues on the next page...

Table 28. SPI (continued)

Symbol	Description	Min	Typ	Max	Unit	Condition	Spec Number
tHI	Input data hold time ⁶	0	—	—	ns	Master, MTFE=1, CPHA=1, SMPL_PTR = 1	10
tHI	Input data hold time ⁶	4	—	—	ns	Slave Receive Mode	10
tSUO	Output data valid time (after SCK edge) ⁹	—	—	5	ns	Master, MTFE=0 max CLOAD=25pF, max pad drive setting, SRE[2:0] = 101	11
tSUO	Output data valid time (after SCK edge) ⁹	—	—	5 + ipg_clk_d spi_perio d	ns	Master, MTFE=1, CPHA=0 max CLOAD=25pF, max pad drive setting, SRE[2:0] = 101	11
tSUO	Output data valid time (after SCK edge) ⁹	—	—	5	ns	Master, MTFE=1, CPHA=1 max CLOAD=25pF, max pad drive setting, SRE[2:0] = 101	11
tSUO	Output data valid time (after SCK edge) ^{7, 9}	—	—	16	ns	Slave Transmit Mode, SRE[2:0] = 101	11
tHO	Output data hold time ⁹	-2	—	—	ns	Master, MTFE=0 max CLOAD=25pF, max pad drive setting, SRE[2:0] = 101	12
tHO	Output data hold time ⁹	-2 + ipg_clk_d spi_perio d	—	—	ns	Master, MTFE=1, CPHA=0 max CLOAD=25pF, max pad drive setting, SRE[2:0] = 101	12
tHO	Output data hold time ⁹	-2	—	—	ns	Master, MTFE=1, CPHA=1 max CLOAD=25pF, max pad drive setting, SRE[2:0] = 101	12
tHO	Output data hold time ⁹	3	—	—	ns	Slave Transmit Mode, SRE[2:0] = 101	—

1. The maximum SPI baud rate that is achievable in a dedicated master-slave connection depends on several parameters that are independent of the SPI module clocking capabilities (e.g. capacitive load of the signal lines, SPI slave clock-to-data delay, pad slew rate, etc.). The maximum achievable SPI baud rate needs to be evaluated in a corresponding SPI master-slave setup.
2. SMPL_PTR should be set to 1. For SPI_CTARN[BR] - 'Baud Rate Scaler' configuration is ≥ 3
3. Slave Receive Mode can operate at a maximum frequency of 60 MHz. In this mode, the DSPI can receive data on SIN, but no valid data is transmitted on SOUT.

4. This value of 20 ns is with the configuration prescaler values: SPI_CTARn[PCSSCK] - "PCS to SCK Delay Prescaler" configuration is "3" (01h) and SPI_CTARn[CSSCK] - "PCS to SCK Delay Scaler" configuration is "2" (0000h)
5. This value of 20 ns is with the configuration prescaler values: SPI_CTARn[PASC] - "After SCK Delay Prescaler" configuration is "3" (01h) and SPI_CTARn[ASC] - "After SCK Delay Scaler" configuration is "2" (0000h)
6. Input timing assumes an input signal slew rate of 2ns (20%/80%).
7. For the case of both master and slave being NXP S32x devices, frequency of operation will be reduced to $[1000 / 2 * \{t_{SUI_master} + t_{SUO_slave} + PCB\ delay\}]$ in ns.
8. N is number of protocol clock cycles where the master samples SIN in MTFE mode after SCK edge.
9. Output timing valid for maximum external load CL = 25pF, which is assumed to be a 10pF load at the end of a 50Ohm, un-terminated, 5 inch microstrip trace on standard FR4 (1.5pF/inch), (25pF total with margin). For best signal integrity, the series resistance of the transmission line should be matched closely to the RDSON of the I/O pad output driver.

Slave mode timing values given below are applicable when device is in MTFE=0.

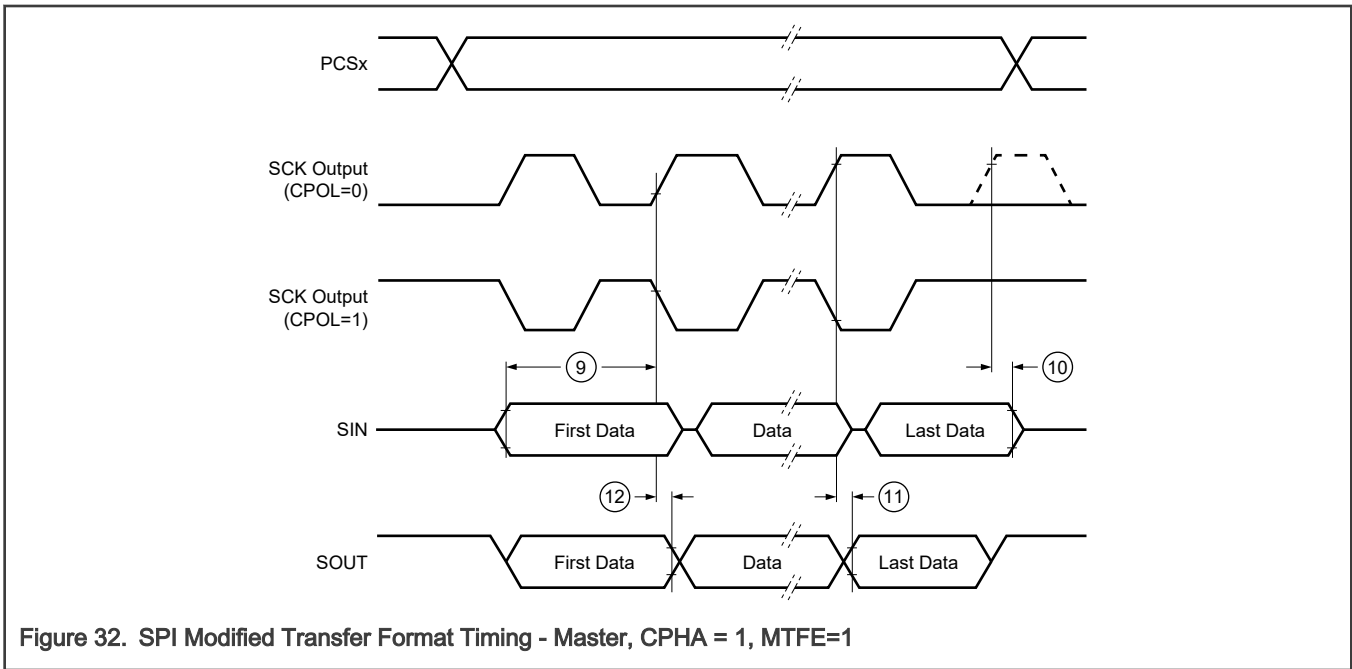

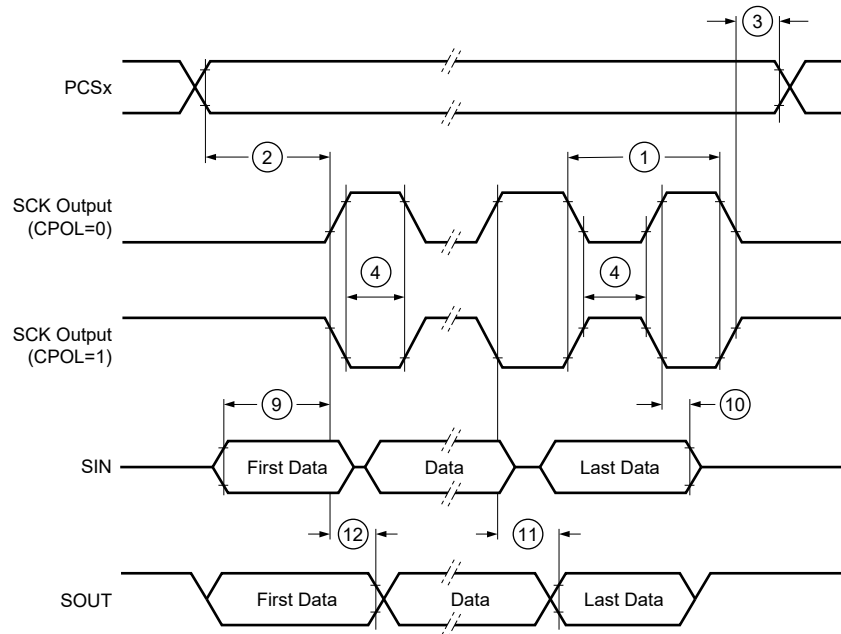

Figure 33. SPI Modified Transfer Format Timing - Master, CPHA = 0, MTFE=1

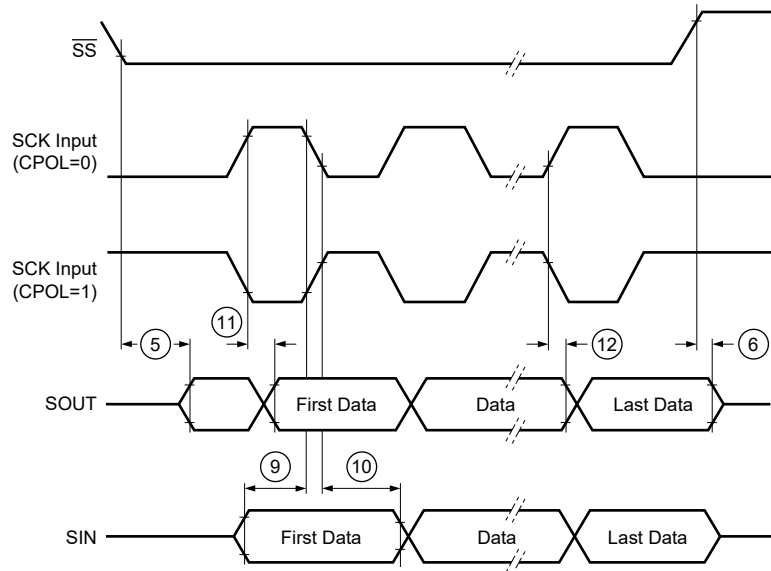

Figure 34. SPI Classic Timing - Slave CPHA = 1, MTFE=0

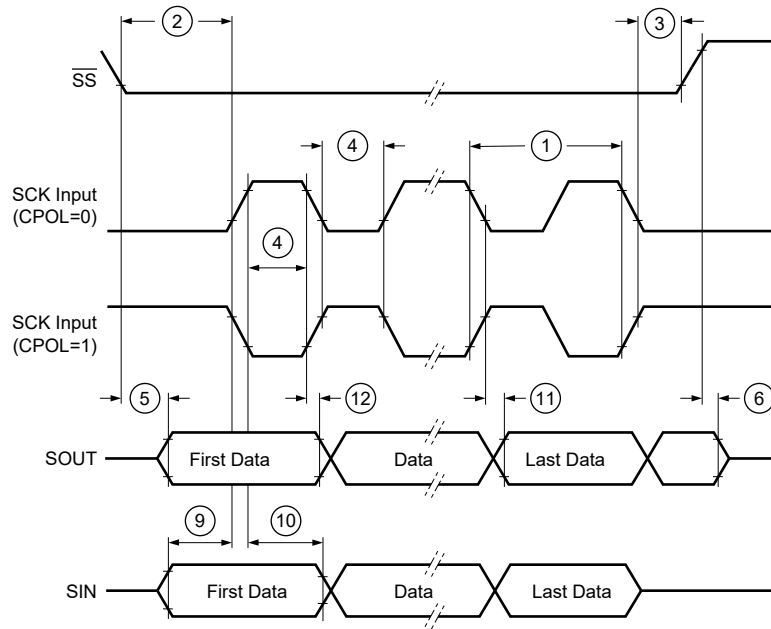

Figure 35. SPI Classic Timing - Slave CPHA = 0, MTFE=0

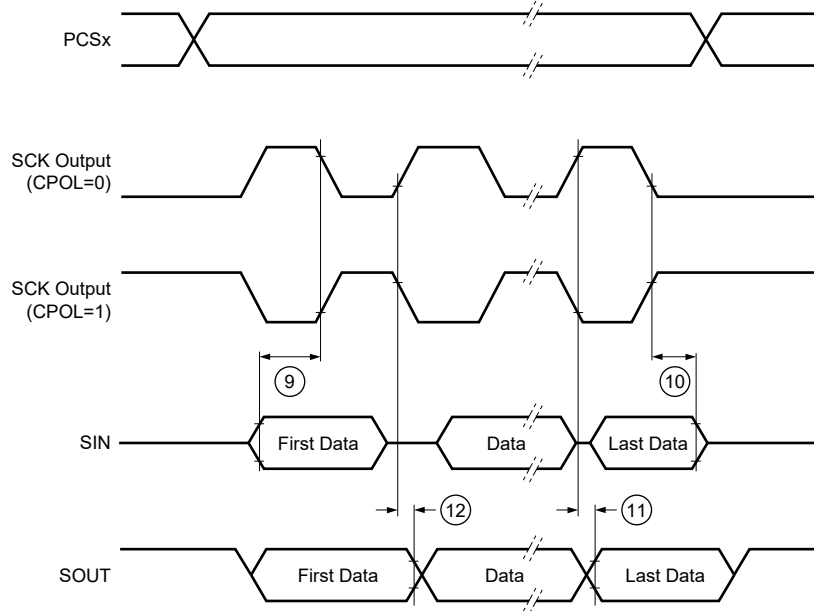

Figure 36. SPI Classic Timing - Master, CPHA = 1, MTFE=0

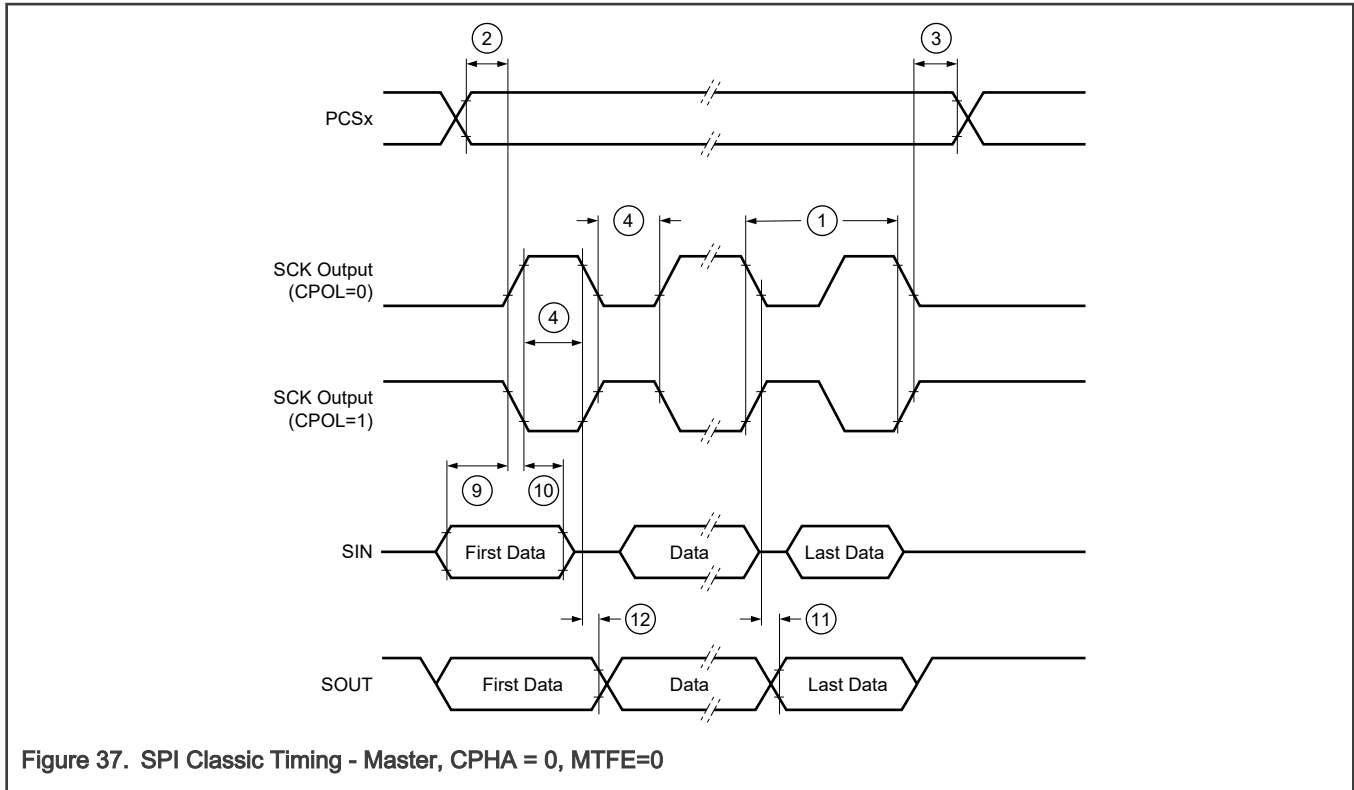

Figure 37. SPI Classic Timing - Master, CPHA = 0, MTFE=0

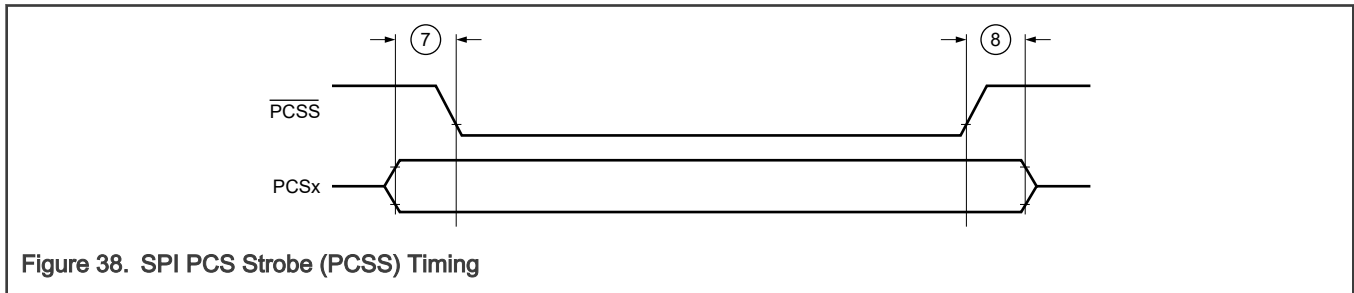

Figure 38. SPI PCS Strobe (PCSS) Timing

16.3.2 I2C

16.3.2.1 I2C Input

Table 29. I2C Input

Symbol	Description	Min	Typ	Max	Unit	Condition	Spec Number
tIH_SC	Input Start condition hold time ^{1,2}	2	—	—	MODULE _CLK cycle	—	1
tCL	Input Clock low time ^{1,2}	8	—	—	MODULE _CLK cycle	—	2
tIH	Input Data hold time ^{1,2}	0	—	—	ns	SDA transitions after SCL falling edge	4

Table continues on the next page...

Table 29. I2C Input (continued)

Symbol	Description	Min	Typ	Max	Unit	Condition	Spec Number
tCH	Input Clock high time ^{1,2}	4	—	—	MODULE_CLK cycle	—	6
tISU	Input Data setup time (standard mode) ^{1,2,3}	250	—	—	ns	SDA transitions before SCL rising edge	7
tISU_F	Input Data setup time (fast mode) ^{1,2,3}	100	—	—	ns	SDA transitions before SCL rising edge	7
tISU_RSC	Input Start condition setup time (repeated start condition) ^{1,2}	2	—	—	MODULE_CLK cycle	—	8
tISU_SC	Input Start condition setup time ^{1,2}	2	—	—	MODULE_CLK cycle	—	9

1. MODULE_CLK from the MC_CGM is the clock driving the I2C block.
2. Input timing assumes an input signal slew rate of 3ns (20%/80%).
3. MODULE_CLK frequency should be greater than 5 MHz for standard mode and 20 MHz for fast mode.

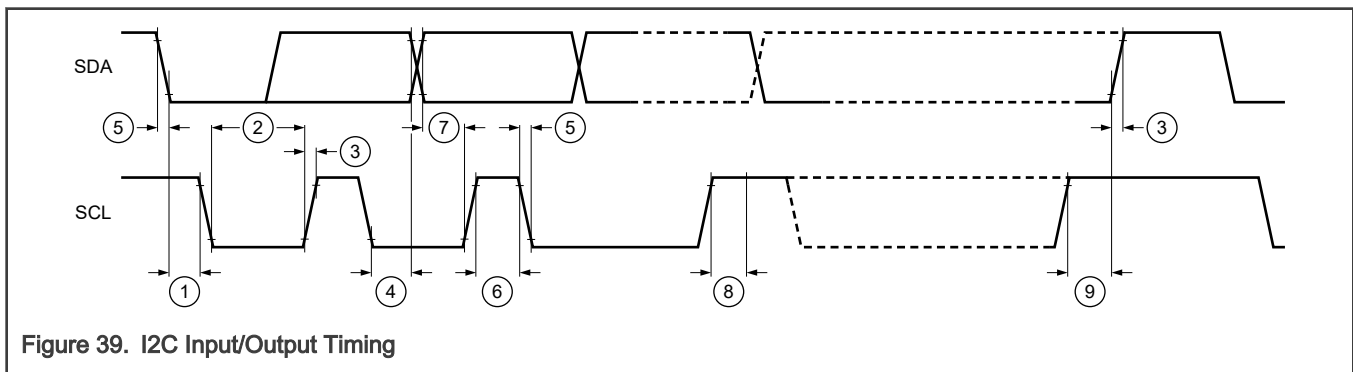

Figure 39. I2C Input/Output Timing

16.3.2.2 I2C Output

Table 30. I2C Output

Symbol	Description	Min	Typ	Max	Unit	Condition	Spec Number
tOH_SC	Output Start condition hold time ^{1,2,3}	6	—	—	MODULE_CLK cycle	—	1
tCL	Output Clock low time ^{1,2,3}	10	—	—	MODULE_CLK cycle	—	2

Table continues on the next page...

Table 30. I2C Output (continued)

Symbol	Description	Min	Typ	Max	Unit	Condition	Spec Number
tRISE	SDA/SCL rise time 1, 2, 3, 4	—	—	100	ns	SRE[2:0] = 110	3
tOH	Output Data hold time 1, 2, 3	7	—	—	MODULE _CLK cycle	SRE[2:0] = 110	4
tFALL	SDA/SCL fall time 1, 2, 3, 4	—	—	100	ns	SRE[2:0] = 110	5
tCH	Output Clock high time 1, 2, 3	10	—	—	MODULE _CLK cycle	SRE[2:0] = 110	6
tOSU	Output Data setup time 1, 2, 3	2	—	—	MODULE _CLK cycle	SRE[2:0] = 110	7
tOSU_RSC	Output repeated start condition setup time 1, 2, 3	20	—	—	MODULE _CLK cycle	SRE[2:0] = 110	8
tOSU_SC	Output start condition setup time 1, 2, 3	11	—	—	MODULE _CLK cycle	SRE[2:0] = 110	9

1. Timing valid for maximum external load CL = 400pF, at the maximum clock frequency defined by the I2C clock high and low time specifications.
2. MODULE_CLK from the MC_CGM is the clock driving the I2C block.
3. Programming IBFD (I2C bus Frequency Divider) with the maximum frequency results in the minimum output timings listed. The I2C interface is designed to scale the data transition time, moving it to the middle of the SCL low period. The actual position is affected by the prescale and division values programmed in IBFD.
4. Because SCL and SDA are open-drain outputs, which the processor can only actively drive low, the time SCL or SDA takes to reach a high level depends on external signal capacitance and pullup resistor values

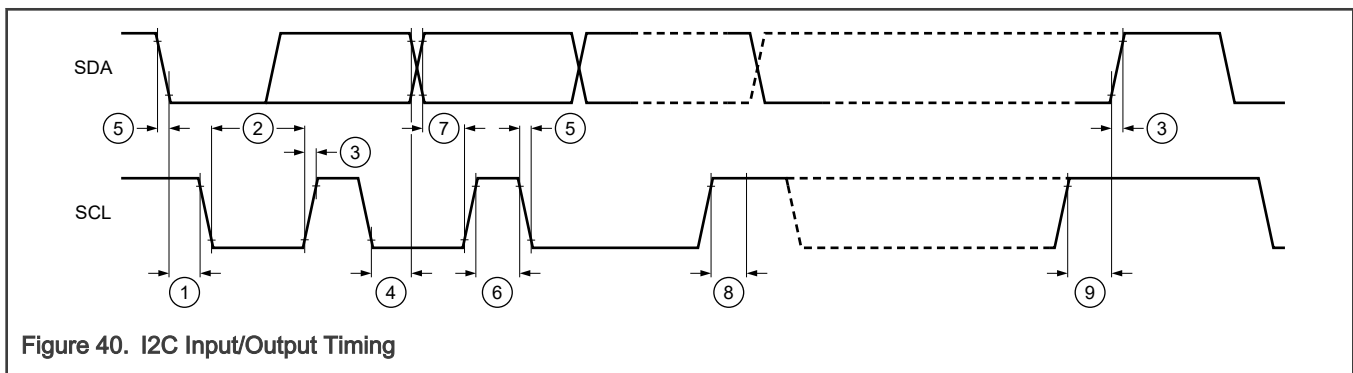

Figure 40. I2C Input/Output Timing

16.3.4 LIN

Table 31. LIN

Symbol	Description	Min	Typ	Max	Unit	Condition	Spec Number
RATE	Bit Rate	—	—	2.0	Mbps	UART mode SRE[2:0] = 110	—
RATE	Bit Rate	4.8	—	20	Kbps	LIN mode SRE[2:0] = 110	—

16.3.5 LPSPI

Table 32. LPSPI

Symbol	Description	Min	Typ	Max	Unit	Condition	Spec Number
fOP	LPSPI operating frequency 1, 2, 3, 4	fPER_CLK / 2048	—	40	MHz	Master	—
fOP	LPSPI operating frequency 3, 4, 5	—	—	20	MHz	Slave	—
tSPSCK	SPSCK period 1, 2, 3, 4	25	—	1 (fPER_CLK / 2048)	ns	Master	—
tSPSCK	SPSCK period 3, 4, 5	50	—	—	ns	Slave	—
tLEAD	Enable lead time (PCS to SPSCK delay) 4, 6, 7	tSPSCK - 3.5	—	—	ns	Master	—
tLEAD	Enable lead time (PCS to SPSCK delay) 4, 6	25	—	—	ns	Slave	—
tLAG	Enable lag time (after SPSCK delay) 4, 8, 9	tSPSCK - 2.5	—	—	ns	Master	—
tLAG	Enable lag time (after SPSCK delay) 4, 8	25	—	—	ns	Slave	—
tSW	Clock (SPSCK) high or low time (duty cycle)	(tSPSCK / 2) - 3	—	(tSPSCK / 2) + 3	ns	Master	—
tSW	Clock (SPSCK) high or low time (duty cycle)	(tSPSCK / 2) - 3	—	(tSPSCK / 2) + 3	ns	Slave	—
tSU	Data setup time (inputs)	12	—	—	ns	Master	—

Table continues on the next page...

Table 32. LPSPI (continued)

Symbol	Description	Min	Typ	Max	Unit	Condition	Spec Number
tSU	Data setup time (inputs)	4	—	—	ns	Slave	—
tHO	Data hold time (inputs)	0	—	—	ns	Master	—
tHO	Data hold time (inputs)	3	—	—	ns	Slave	—
tA	Slave access time	—	—	12.5	ns	Slave	—
tDIS	Slave MISO disable time	—	—	12.5	ns	Slave	—
tV	Data valid (after SPSC edge) 4, 10, 11	—	—	6	ns	Master, SRE[2:0] = 101	—
tV	Data valid (after SPSC edge) 4, 10, 11	—	—	20	ns	Slave, SRE[2:0] = 101	—
tHO	Data hold time (outputs) 4, 10, 11	0	—	—	ns	Master, SRE[2:0] = 101	—
tHO	Data hold time (outputs) 4, 10, 11	0	—	—	ns	Slave, SRE[2:0] = 101	—
tRI_FI	Rise / Fall time (input) 12	—	—	1	ns	Master + Slave	—

1. The maximum master mode LPSPI clock frequency can be no more than the peripheral clock frequency divided by 2.
2. fPER_CLK is the frequency of the device peripheral clock (PER_CLK).
3. The maximum LPSPI baud rate that is achievable in a dedicated master-slave connection depends on several parameters that are independent of the LPSPI module clocking capabilities (e.g. capacitive load of the signal lines, SPI slave clock-to-datadelay, pad slew rate, etc.). The maximum achievable LPSPI baud rate needs to be evaluated in a corresponding SPI master-slave setup.
4. All timing valid to 20% and 80% levels of the LPSPI I/O voltage supply on the device.
5. The maximum slave mode LPSPI clock frequency can be no more than the peripheral clock frequency divided by 4.
6. Set the PCSSCK configuration bit as 0, for a minimum of 1 delay cycle of LPSPI baud rate clock, where PCSSCK ranges from 0 to 255.
7. $t_{PCSSCK} = (PCSSCK+1) * (2^{**}PRESCALE) * (1 / f_{PER_CLK})$
8. Set the SCKPCS configuration bit as 0, for a minimum of 1 delay cycle of LPSPI baud rate clock, where SCKPCS ranges from 0 to 255.
9. $t_{SCKPCS} = (SCKPCS+1) * (2^{**}PRESCALE) * (1 / f_{PER_CLK})$
10. Timing valid for maximum external load CL = 25pF, which is assumed to be a 10pF load at the end of a 50ohm, un-terminated, 5 inch microstrip trace on standard FR4 (1.5pF/inch), (25pF total with margin). For best signal integrity, the series resistance in the transmission line should be equal to the selected RDSON of the I/O pad output.
11. Output rise/fall time is determined by the output load and GPIO pad drive strength setting. See the GPIO specifications for detail.
12. The input rise/fall time specification applies to both clock and data, and is required to guarantee related timing parameters.

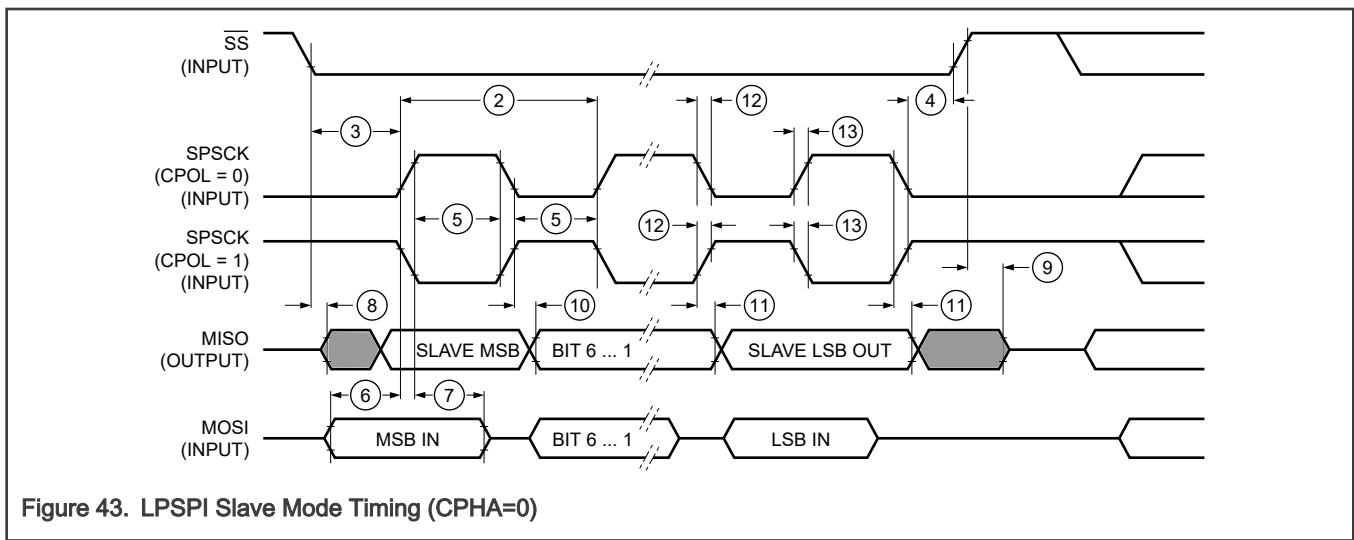
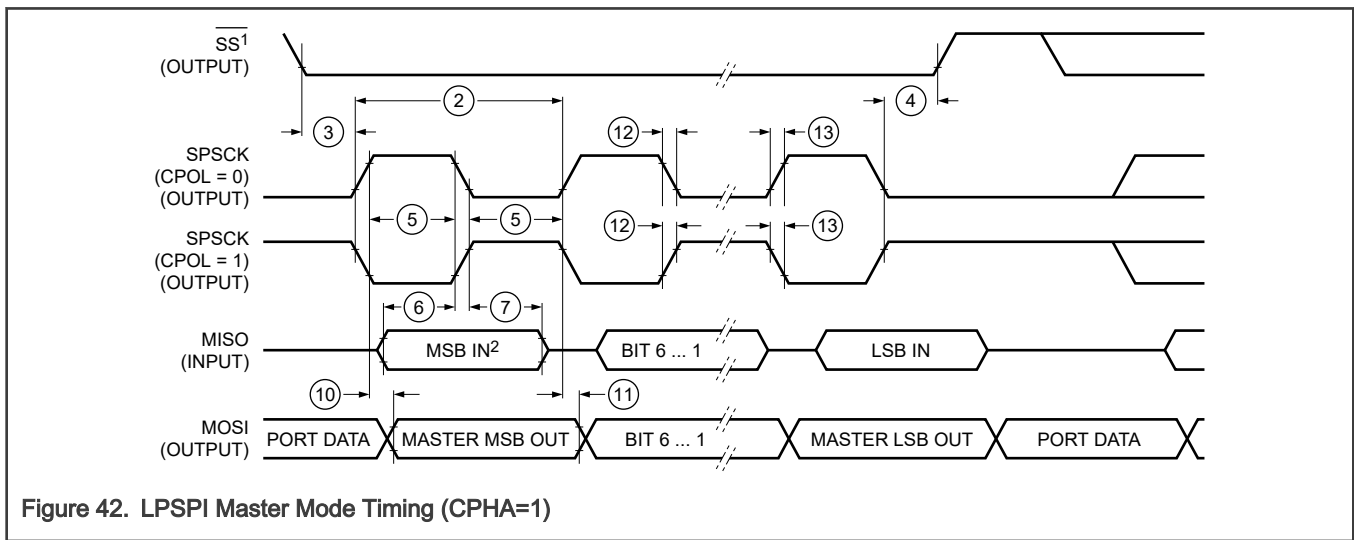
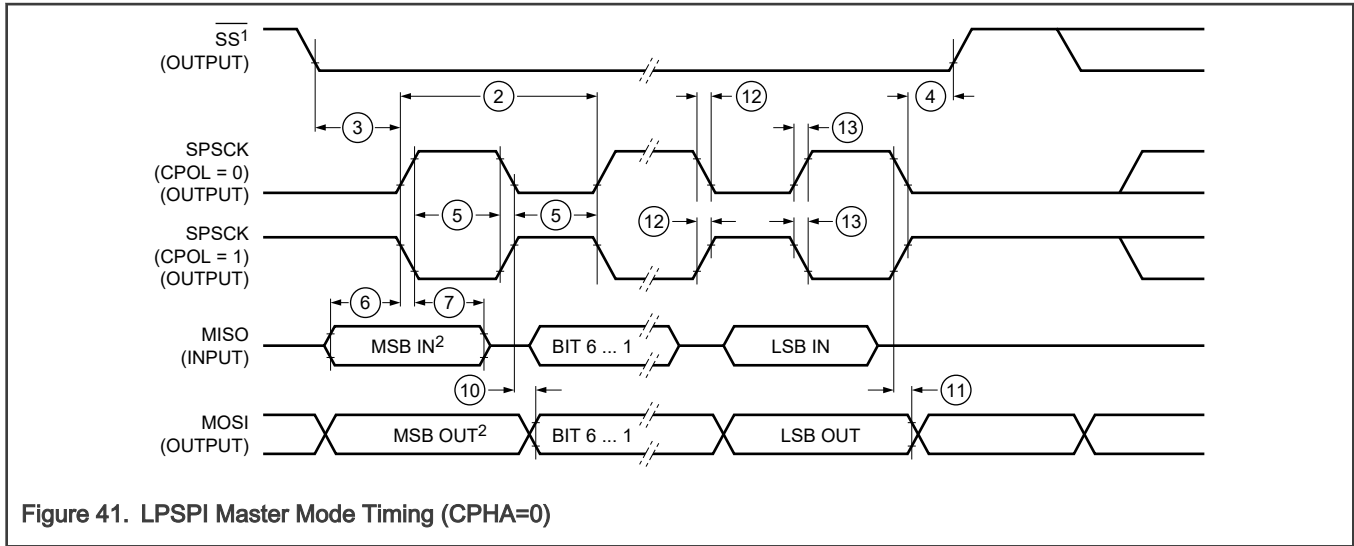

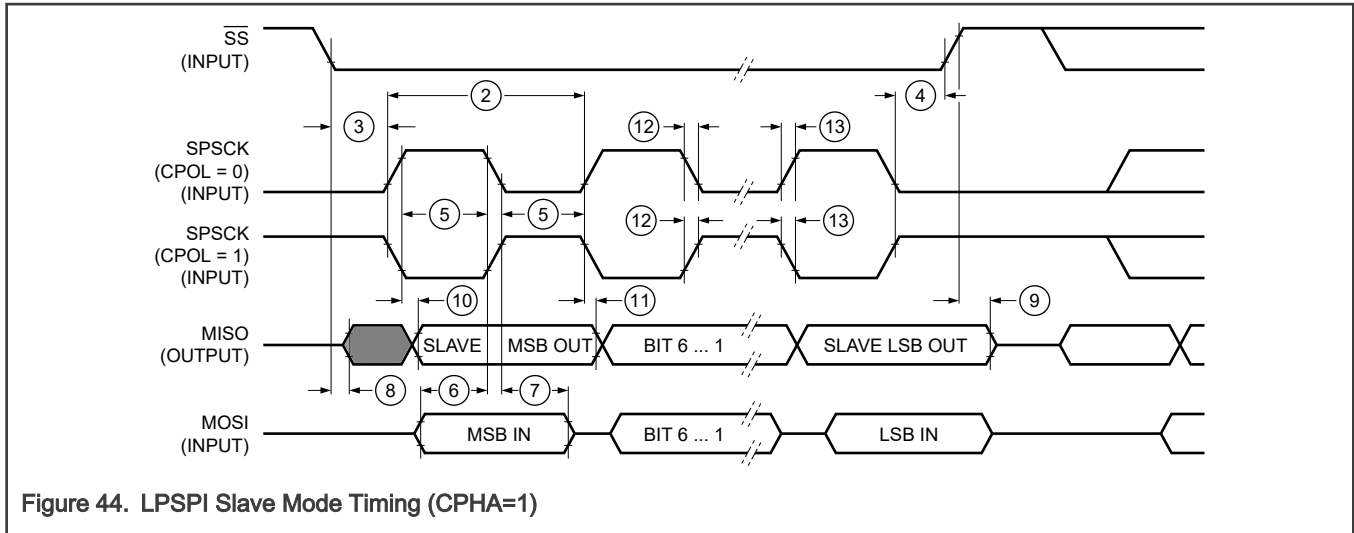

16.3.6 CAN

See GPIO pads for CAN specifications.

16.4 FlexRay

16.4.1 FlexRay - RxD

Table 33. FlexRay - RxD

Symbol	Description	Min	Typ	Max	Unit	Condition	Spec Number
C_CCRxD	Input capacitance on RxD pin	—	—	8	pF	—	—
dCCRxD01	Sum of delay from actual input to the D input of the first FF, rising edge ¹	—	—	10	ns	—	—
dCCRxD10	Sum of delay from actual input to the D input of the first FF, falling edge ¹	—	—	10	ns	—	—
dCCRxAsymAccep t15	Acceptance of asymmetry at receiving CC with 15pF load ¹	-31.5	—	44	ns	—	—
dCCRxAsymAccep t25	Acceptance of asymmetry at receiving CC with 25pF load ¹	-30.5	—	43	ns	—	—

1. FlexRay RxD timing assumes an input signal slew rate of 2ns (20%/80%).

16.4.2 FlexRay - TxD

Table 34. FlexRay - TxD

Symbol	Description	Min	Typ	Max	Unit	Condition	Spec Number
dCCTxAsym	Asymmetry of sending CC, dCCTxD50% - N x gdBit ¹	-2.45	—	2.45	ns	N=1, gdBit = 100ns, TxD load = 25pF max, SRE[2:0] = 110 (3.3V GPIO)	—
dCCTxDRISE25 + dCCTxDFALL25	Sum of rise and fall time of TxD signal at the output pin ¹	—	—	9	ns	TxD load = 25pF max, Z = 50ohms, delay = 0.6ns, SRE[2:0] = 110 (3.3V GPIO)	—
dCCTxD01	Sum of delay between Clk to Q of the last FF and the final output buffer, rising edge ¹	—	—	25	ns	TxD load = 25pF max, SRE[2:0] = 110 (3.3V GPIO)	—
dCCTxD10	Sum of delay between Clk to Q of the last FF and the final output buffer, falling edge ¹	—	—	25	ns	TxD load = 25pF max, SRE[2:0] = 110 (3.3V GPIO)	—

1. Timing valid for maximum external load CL = 25pF, which is assumed to be a 8pF load at the end of a 50Ohm, un-terminated, 5 inch microstrip trace on standard FR4 (1.5pF/inch). For best signal integrity, the series resistance of the transmission line should be matched closely to the RDSON of the I/O pad output driver.

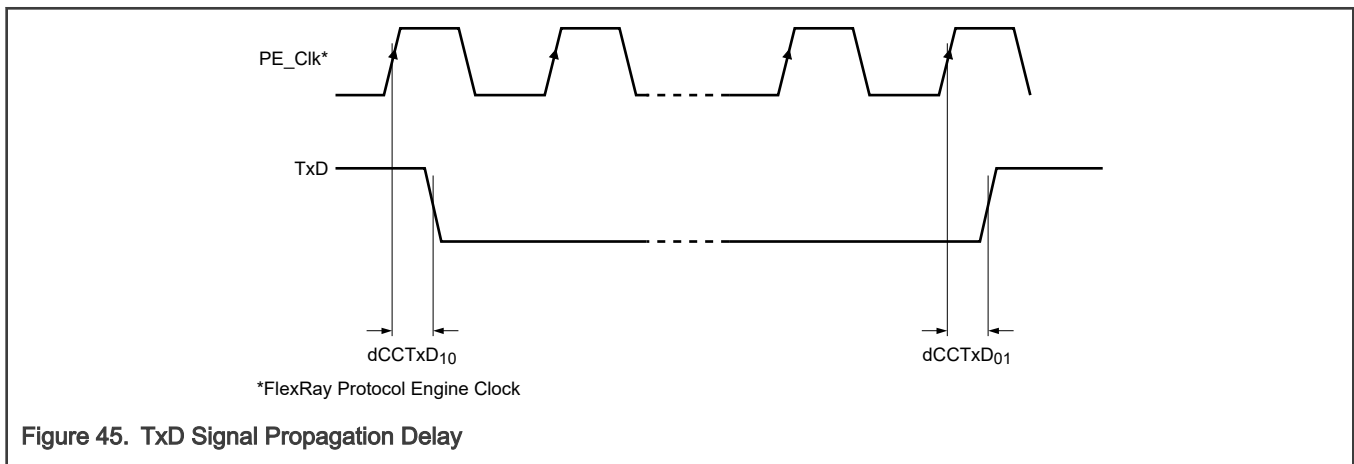

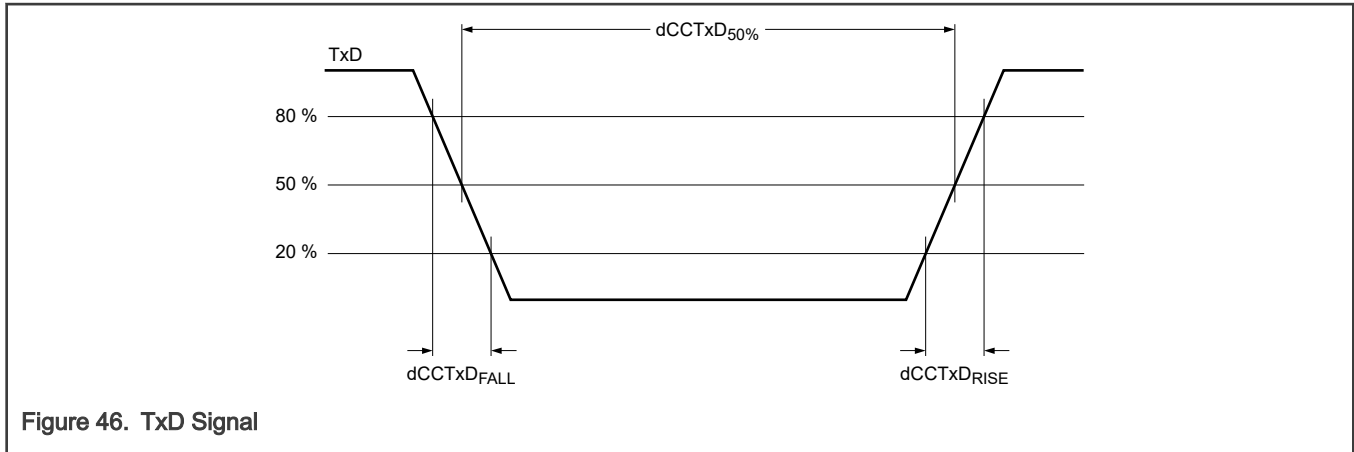

Figure 46. TxD Signal

16.4.3 FlexRay - TxEN

Table 35. FlexRay - TxEN

Symbol	Description	Min	Typ	Max	Unit	Condition	Spec Number
dCCTxENRISE25	Rise time of TxEN signal at CC ¹	—	—	9	ns	TxEN load = 25pF max, SRE[2:0] = 110 (3.3V GPIO)	—
dCCTxENFALL25	Fall time of TxEN signal at CC ¹	—	—	9	ns	TxEN load = 25pF max, SRE[2:0] = 110 (3.3V GPIO)	—
dCCTxEN01	Sum of delay between Clk to Q of the last FF and the final output buffer, rising edge ¹	—	—	25	ns	TxEN load = 25pF max, SRE[2:0] = 110 (3.3V GPIO)	—
dCCTxEN10	Sum of delay between Clk to Q of the last FF and the final output buffer, falling edge ¹	—	—	25	ns	TxEN load = 25pF max, SRE[2:0] = 110 (3.3V GPIO)	—

1. Timing valid for maximum external load $CL = 25pF$, which is assumed to be a 8pF load at the end of a 50Ohm, un-terminated 5 inch microstrip trace on standard FR4 (1.5pF/inch), (25pF total with margin). For best signal integrity, the series resistance of the transmission line should be matched closely to the RDSON of the I/O pad output driver.

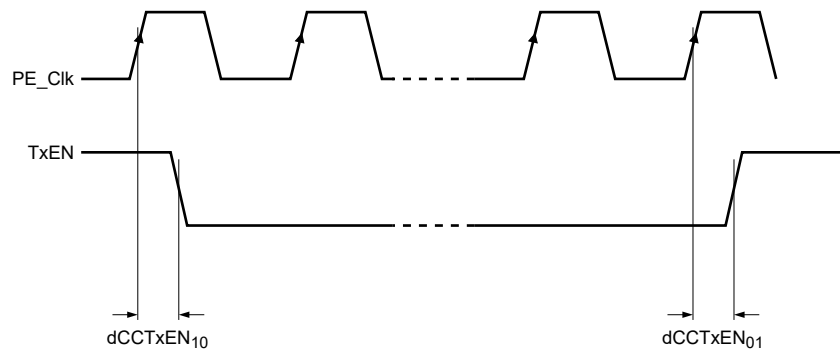

Figure 47. TxEN Signal Propagation Delay

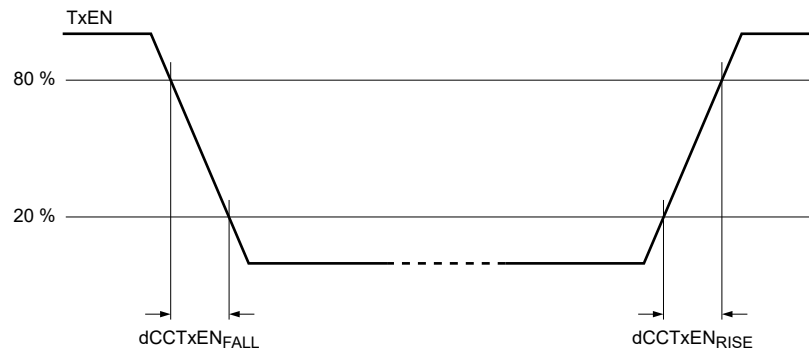

Figure 48. TxEN Signal

16.9 PCIe

Table 36. PCIe

Symbol	Description	Min	Typ	Max	Unit	Condition	Spec Number
UI	Unit Interval ¹	399.88	—	400.12	ps	2.5GT/s	—
UI	Unit Interval ¹	199.94	—	200.06	ps	5.0GT/s	—
UI	Unit Interval ¹	124.9625	—	125.0375	ps	8.0GT/s	—
VTX-DIFF-PP	Differential p-p Tx voltage swing ¹	0.8	—	1.2	Vp-p	2.5GT/s, 5.0GT/s	—
VTX-DE-RATIO-3.5dB	Tx de-emphasis level ratio ¹	2.5	—	4.5	dB	2.5GT/s, 5.0GT/s	—
VTX-DE-RATIO-6dB	Tx de-emphasis level ratio ¹	5	—	7	dB	5.0GT/s	—
TMIN-PULSE	Instantaneous lone pulse width ¹	0.9	—	—	UI	5.0GT/s	—
TTX-EYE	Transmitter Eye including all jitter sources ¹	0.75	—	—	UI	2.5GT/s, 5.0GT/s	—

Table continues on the next page...

Table 36. PCIe (continued)

Symbol	Description	Min	Typ	Max	Unit	Condition	Spec Number
TTX-HF-DJ-DD	Tx deterministic jitter > 1.5 MHz ¹	—	—	0.15	UI	5.0GT/s	—
TTX-LF-RMS	Tx RMS jitter < 1.5 MHz ¹	—	3	—	ps RMS	5.0GT/s	—
BWTX-PKG-PLL1	Tx PLL BW corresponding to PKGTX-PLL1 ¹	8	—	16	MHz	5.0GT/s	—
BWTX-PKG-PLL1	Tx PLL BW corresponding to PKGTX-PLL1 ¹	2	—	4	MHz	8.0GT/s	—
BWTX-PKG-PLL2	Tx PLL BW corresponding to PKGTX-PLL2 ¹	5	—	16	MHz	5.0GT/s	—
BWTX-PKG-PLL2	Tx PLL BW corresponding to PKGTX-PLL2 ¹	2	—	5	MHz	8.0GT/s	—
PKGTX-PLL1	Tx PLL peaking ¹	—	—	3	dB	5.0GT/s	—
PKGTX-PLL1	Tx PLL peaking ¹	—	—	2	dB	8.0GT/s	—
PKGTX-PLL2	Tx PLL peaking ¹	—	—	1	dB	5.0GT/s	—
PKGTX-PLL2	Tx PLL peaking ¹	—	—	1	dB	8.0GT/s	—
BWTX-PLL	Maximum Tx PLL bandwidth ¹	1.5	—	22	MHz	2.5GT/s	—
TTX-EYE-MEDIAN-to-MAXJITTER	Maximum time between the jitter median and max deviation from the median ¹	—	—	0.125	UI	2.5GT/s	—
VTX-FS-NO-EQ	Full Swing Tx voltage with no TxEq ¹	800	—	1300	mVPP	8.0GT/s	—
VTX-EIEOS-FS	Min Swing during EIEOS for full swing ¹	250	—	—	mVPP	8.0GT/s	—
TTX-UTJ	Tx uncorrelated total jitter ¹	—	—	31.25	ps PP @ 10e-12	8.0GT/s	—
TTX-UDJDD	Tx uncorrelated deterministic jitter ¹	—	—	12	ps PP	8.0GT/s	—
VTX-BOOST-FS	Tx boost ratio for full swing ¹	8	—	—	dB	8.0GT/s	—

Table continues on the next page...

Table 36. PCIe (continued)

Symbol	Description	Min	Typ	Max	Unit	Condition	Spec Number
VRX-DIFF-PP-CC	Differential Rx peak-peak voltage for common Refclk Rx architecture ¹	0.175	—	1.2	V	2.5GT/s	—
VRX-DIFF-PP-CC	Differential Rx peak-peak voltage for common Refclk Rx architecture ¹	0.12	—	1.2	V	5.0GT/s	—
TRX-EYE	Receiver eye time opening ¹	0.4	—	—	UI	2.5GT/s	—
TRX-EYE	Receiver eye time opening ¹	0.4	—	—	UI	2.5GT/s	—
TRX-TJ-CC	Max Rx inherent timing error ¹	—	—	0.4	UI	5.0GT/s	—
TRX-DJ-DD_CC	Max Rx deterministic timing error ¹	—	—	0.3	UI	5.0GT/s	—
VRX-EYE	Receive eye voltage opening ¹	—	120	—	mVPP diff	5.0GT/s	—
VRX-EYE	Receive eye voltage opening ¹	—	120	—	mVPP diff	5.0GT/s	—
VRX-SV-8G	Eye height at TP2P ¹	—	25	—	mVPP	8.0GT/s, -20dB Ch	—
VRX-SV-8G	Eye height at TP2P ¹	—	50	—	mVPP	8.0GT/s, -12dB Ch	—
VRX-SV-8G	Eye height at TP2P ¹	—	200	—	mVPP	8.0GT/s, -3dB Ch	—
TRX-SV-8G	Eye width at TP2P ¹	0.3	—	0.35	UI	8.0GT/s	—
TRX-SV-SJ-8G	Sinusoidal Jitter at 100MHz ¹	—	0.1	—	UI PP	8.0GT/s	—
TRX-SV-RJ-8G	Random Jitter ¹	—	2	—	ps RMS	8.0GT/s	—
REXTPCIe	External pin calibration resistance	198	200	202	Ω	—	—
RJREFCLK	Reference clock random jitter (rms) ¹	—	—	3	ps	Integrated RJ from 12kHz to 20MHz	—
RJREFCLK	Reference clock random jitter (rms) ¹	—	—	2.2	ps	Integrated RJ from 2MHz to 20MHz	—
DJREFCLK	Reference clock deterministic jitter (pk-pk) ¹	—	—	5.7	ps	200kHz to 100MHz	—

Table continues on the next page...

Table 36. PCIe (continued)

Symbol	Description	Min	Typ	Max	Unit	Condition	Spec Number
DJREFCLK	Reference clock deterministic jitter (pk-pk) ¹	—	—	2.8	ps	1MHz to 20MHz	—
RJ_SGMII	Reference clock random jitter (rms)	—	—	2.3	ps	Integrated RJ from 12kHz to 20MHz	—
RJ_SGMII	Reference clock random jitter (rms)	—	—	1.7	ps	Integrated RJ from 2MHz to 20MHz	—
DJ_SGMII	Reference clock deterministic jitter (pk-pk)	—	—	7.4	ps	1MHz to 100MHz	—
DJ_SGMII	Reference clock deterministic jitter (pk-pk)	—	—	3.7	ps	3MHz to 20MHz	—
FREF_OFFSET	Reference clock frequency offset	-150	—	150	ppm	—	—
DCREF_CLK	Duty cycle	40	—	60	%	—	—
VREF_CLK	Voltage level	0	—	VDD_VP_PCIE	V	—	—
IS_DIFF	Differential input swing	0.3	—	—	Vpp	—	—
SWREF_CLK	Input edge rate	0.4	—	2	V/ns	—	—
REF_CL_SKEW	Reference clock skew	—	—	200	ps	—	—

1. The PCI Express link conforms to the PCI Express Base Specification, Revision 3.1. The summary of Transmitter and Receiver specifications are copied directly from the Base Specification. Consult the Base Specification for additional details.

NXP completed PCI-SIG compliance testing with the following PHY registers modified from default settings as described below. PHY register and programming details are provided in S32SERDESSUBSYSRM. PHY TX settings optimized for NXP validation board for SUP_ANA_TERM_CTRL = 4 and TX_VBOOST_LVL = 4. PHY PLL bandwidth updated for MPLL_BW_OVRD_VAL = 218 and MPLLA_BW_OVRD_VAL = 197.

NXP internally does PCI-SIG TX compliance testing using external reference clock source.

16.6 GMAC and PFE

16.6.1 GMAC and PFE Management Interface

Table 37. GMAC and PFE Management Interface

Symbol	Description	Min	Typ	Max	Unit	Condition	Spec Number
fMDC	MDC clock frequency	—	—	2.5	MHz	—	MDC00
MDIO_CH	MDC pulse width high time	40	—	60	%	—	MDC14
MDIO_CL	MDC pulse width low time	40	—	60	%	—	MDC15
MDIO_DOI	MDC falling edge to MDIO output invalid (minimum propagation delay)	0	—	—	ns	SRE[2:0] = 100	MDC10
MDIO_DOV	MDC falling edge to MDIO output valid (maximum propagation delay)	—	—	15	ns	SRE[2:0] = 100	MDC11
MDIO_ISU	MDIO (input) to MDC rising edge setup time	13	—	—	ns	—	MDC12
MDIO_IH	MDIO (input) to MDC rising edge hold time	0	—	—	ns	—	MDC13

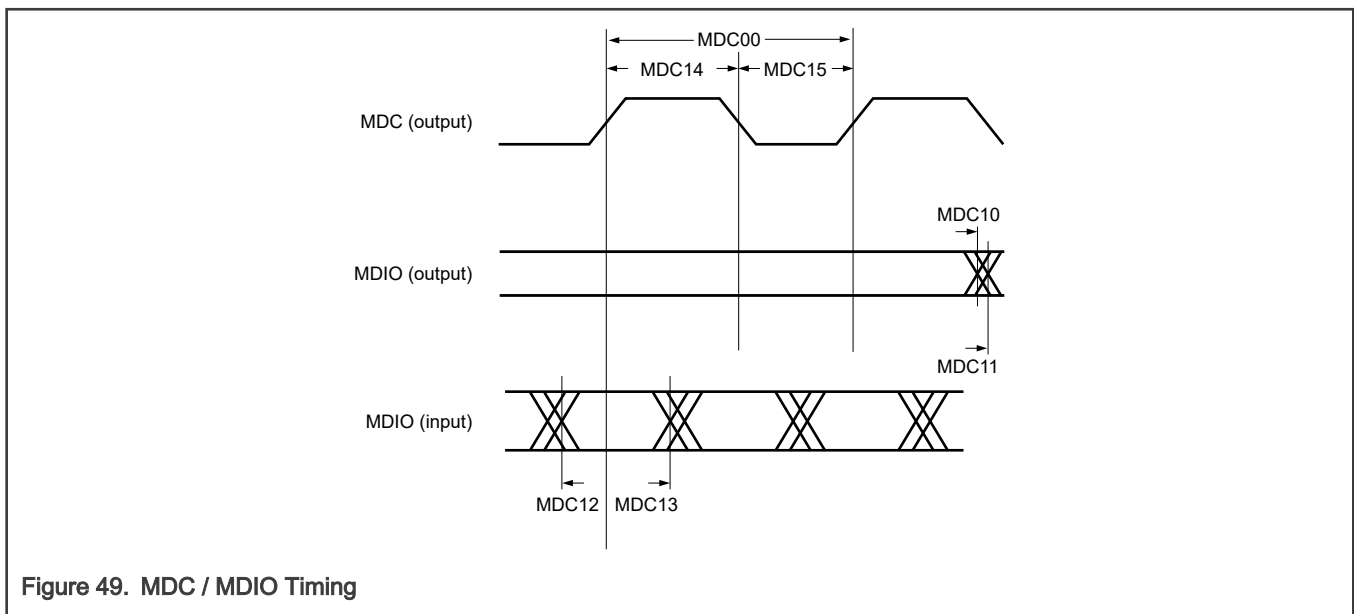

Figure 49. MDC / MDIO Timing

16.6.2 GMAC and PFE MII

Table 38. GMAC and PFE MII

Symbol	Description	Min	Typ	Max	Unit	Condition	Spec Number
tCYC_RX	RX_CLK period	—	40 / 400	—	ns	10/100 Mbps	—
ΔtCYC_RX	RX_CLK duty cycle (tPWH / tCYC)	45	—	55	%	—	—
tS	Input setup time to RX_CLK ¹	5	—	—	ns	10/100 Mbps	—
tH	Input hold time to RX_CLK ¹	5	—	—	ns	10/100 Mbps	—
tCYC_TX	TX_CLK period ²	—	40 / 400	—	ns	10/100 Mbps, SRE[2:0] = 100	—
ΔtCYC_TX	TX_CLK duty cycle (tPWH / tCYC) ²	45	—	55	%	SRE[2:0] = 100	—
tD	Output delay from TX_CLK ²	2	—	25	ns	10/100 Mbps, SRE[2:0] = 100	—

1. Input timing assumes an input signal slew rate of 3ns (20%/80%).
2. Output timing valid for maximum external load CL = 25pF, which is assumed to be a 10pF load at the end of a 50Ohm, un-terminated, 5 inch microstrip trace on standard FR4 (1.5pF/inch), (25pF total with margin). For best signal integrity, the series resistance of the transmission line should be matched closely to the RDSON of the I/O pad output driver.

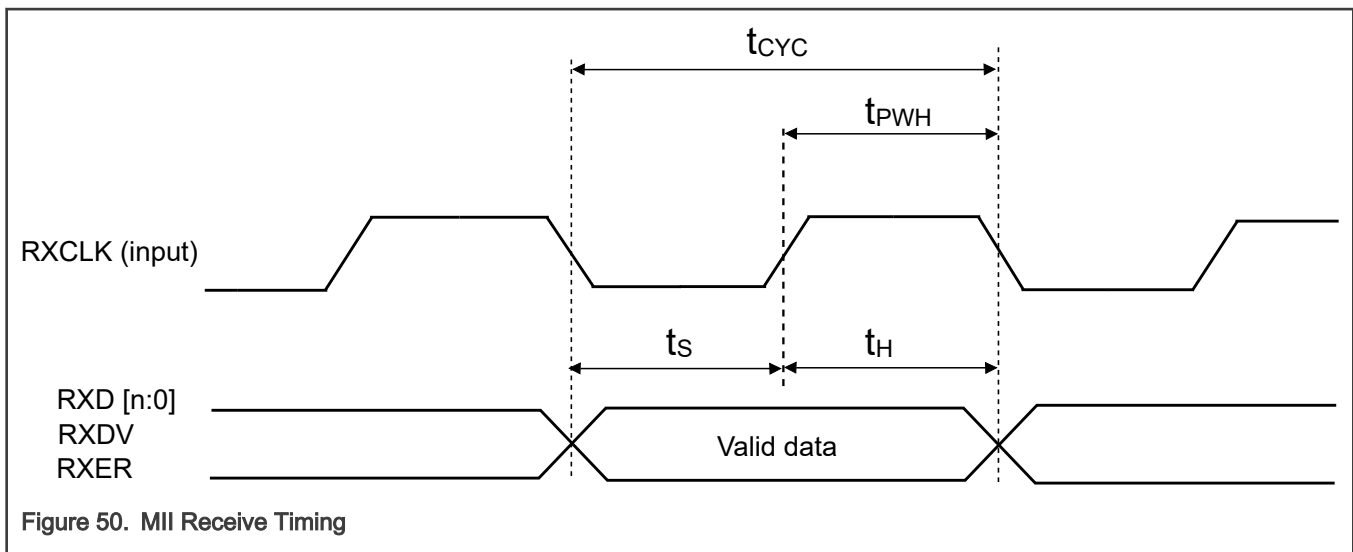

Figure 50. MII Receive Timing

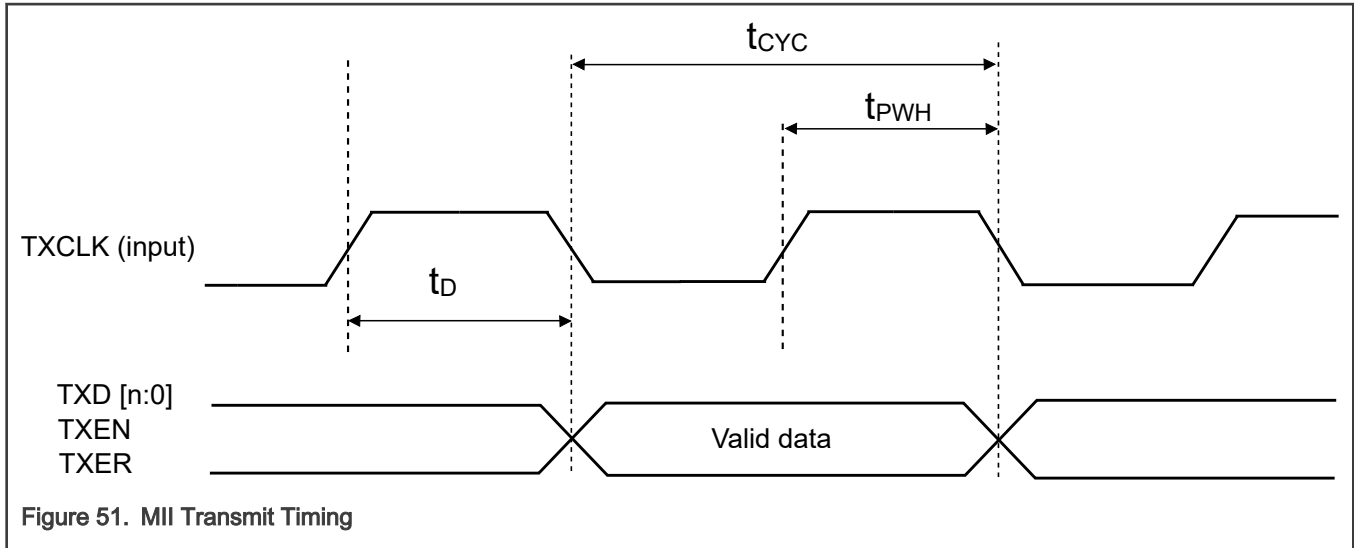

Figure 51. MII Transmit Timing

16.6.3 GMAC MII 50MHz

NOTE

GMAC MII 50MHz spec apply to GMAC only.

Table 39. GMAC MII 50MHz

Symbol	Description	Min	Typ	Max	Unit	Condition	Spec Number
fRXCLK	RXCLK frequency ¹	—	—	50	MHz	—	—
dtRXCLK	RXCLK pulse width high ¹	35	—	65	% RXCLK period	—	E3
dtRXCLK	RXCLK pulse width low ¹	35	—	65	% RXCLK period	—	E4
tSETUP	RXD[3:0], RXDV, RXER to RXCLK setup time ¹	4	—	—	ns	—	—
tHOLD	RXCLK to RXD[3:0], RXDV, RXER hold time ¹	2	—	—	ns	—	—
fTXCLK	TXCLK frequency ²	—	—	50	MHz	—	—
dtTXCLK	TXCLK pulse width high ²	35	—	65	% TXCLK period	—	E7
dtTXCLK	TXCLK pulse width low ²	35	—	65	% TXCLK period	—	E8

Table continues on the next page...

Table 39. GMAC MII 50MHz (continued)

Symbol	Description	Min	Typ	Max	Unit	Condition	Spec Number
tDATA_VALID	TXCLK to TXD[3:0], TXDV, TXER valid ²	—	—	15	ns	—	E6
tDATA_INVALID	TXCLK to TXD[3:0], TXDV, TXER invalid ²	2	—	—	ns	—	E5

1. Input timing assumes an input signal slew rate of 3ns (20%/80%).
2. Output timing valid for maximum external load CL = 25pF, which is assumed to be a 10pF load at the end of a 50Ohm, un-terminated, 5 inch microstrip trace on standard FR4 (1.5pF/inch, (25pF total with margin). For best signal integrity, the series resistance in the transmission line should be matched closely to the selected RDSON of the I/O pad output driver.

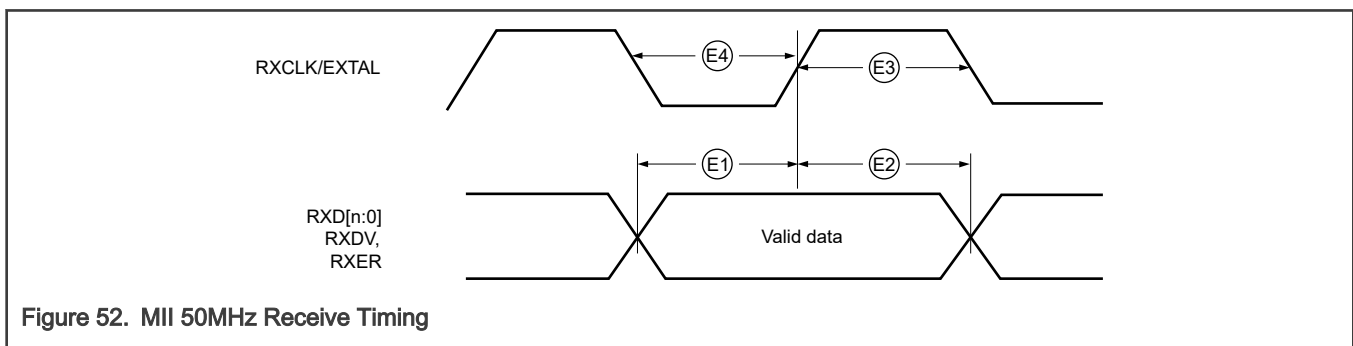

Figure 52. MII 50MHz Receive Timing

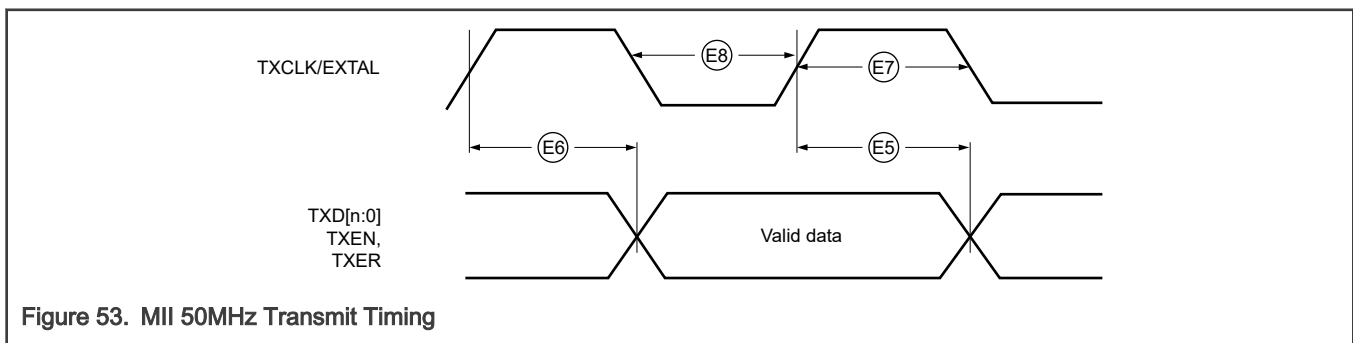

Figure 53. MII 50MHz Transmit Timing

16.6.4 GMAC and PFE RMII

Table 40. GMAC and PFE RMII

Symbol	Description	Min	Typ	Max	Unit	Condition	Spec Number
fRMII_CLK	RMII input clock frequency (RMII_CLK)	—	—	50	MHz	—	—
ΔtRMII_CLK	RMII_CLK duty cycle (tPWH / tCYC)	35	—	65	%	—	E3, E4, E7, E8
tS	RXD[1:0], CRS_DV, RXER to RMII_CLK setup time ¹	4	—	—	ns	—	E1

Table continues on the next page...

Table 40. GMAC and PFE RMII (continued)

Symbol	Description	Min	Typ	Max	Unit	Condition	Spec Number
tH	RMII_CLK to RXD[1:0], CRS_DV, RXER hold time ¹	2	—	—	ns	—	E2
tDATA_VALID	RMII_CLK to TXD[1:0], TXEN data valid ²	—	—	14	ns	CLOAD = 25pF, SRE[2:0] = 100	E6
tDATA_INVALID	RMII_CLK to TXD[1:0], TXEN data invalid ²	2	—	—	ns	CLOAD = 25pF, SRE[2:0] = 100	E5

1. Input timing assumes an input signal slew rate of 3ns (20%/80%).
2. Output timing valid for maximum external load CL = 25pF, which is assumed to be a 10pF load at the end of a 50Ohm, un-terminated, 5 inch microstrip trace on standard FR4 (1.5pF/inch), (25pF total with margin). For best signal integrity, the series resistance of the transmission line should be matched closely to the RDSON of the I/O pad output driver.

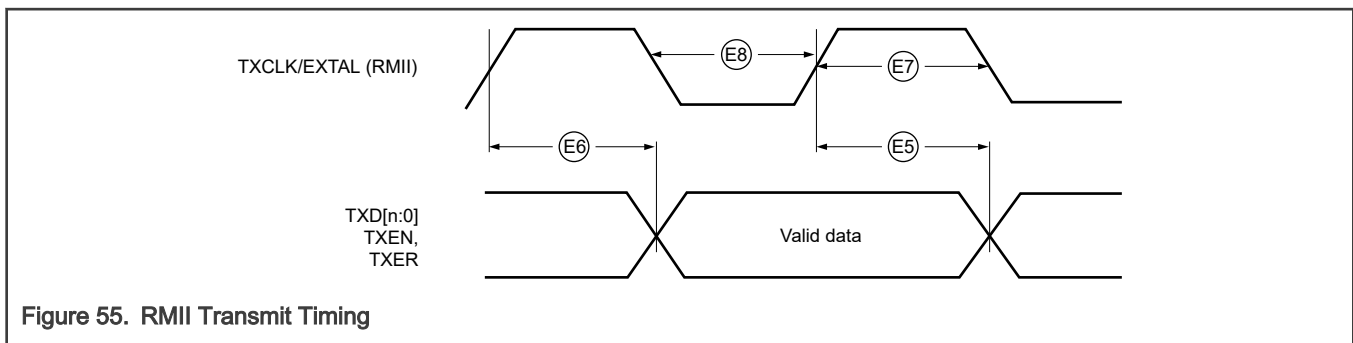
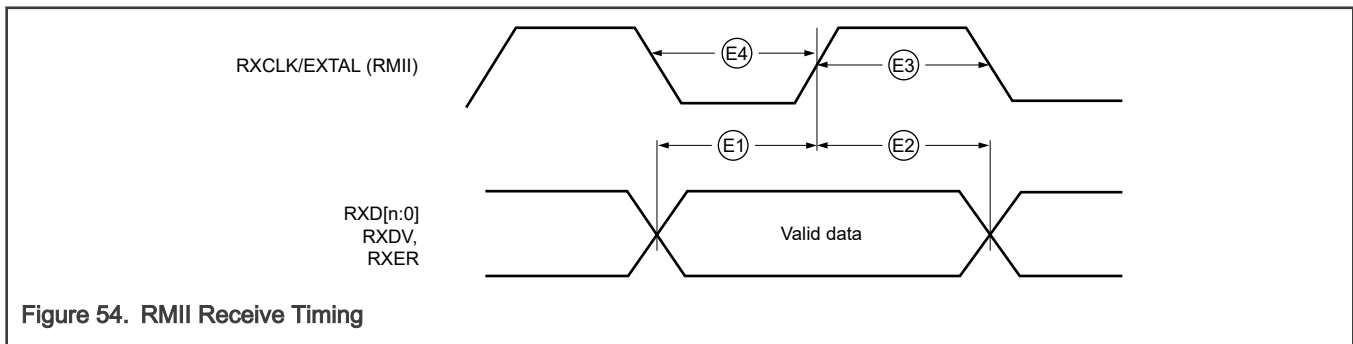

16.6.5 GMAC and PFE RGMII

You must set SRE[2:0]=101 for PFE_MAC0_TX_CLK in RGMII mode of PFE GMAC0 at 3.3V.

Table 41. GMAC and PFE RGMII

Symbol	Description	Min	Typ	Max	Unit	Condition	Spec Number
Tcyc	Clock cycle duration ^{1, 2, 3, 4}	7.2	—	8.8	ns	SRE[2:0] = 100	—

Table continues on the next page...

Table 41. GMAC and PFE RGMII (continued)

Symbol	Description	Min	Typ	Max	Unit	Condition	Spec Number
TskewT	Data to clock output skew (at transmitter) 2, 3, 4, 5	-500	—	500	ps	SRE[2:0] = 100	—
TskewR	Data to clock input skew (at receiver) 2, 4, 5	1	—	2.6	ns	SRE[2:0] = 100	—
Duty_G	Clock duty cycle for Gigabit 2, 4, 6	45	—	55	%	SRE[2:0] = 100	—
Duty_T	Clock duty cycle for 10/100T 2, 4, 6	40	—	60	%	SRE[2:0] = 100	—

- For 10 Mbps and 100 Mbps, T_{cy} will scale to 400 ns ±40 ns and 40 ns ±4 ns respectively.
- Measured as defined in EIA/JESD 8-6 1995 with a timing threshold voltage of V_{DDQ}/2
- Output timing valid for maximum external load CL = 15pF, which is assumed to be a 8pF load at the end of a 50ohm, un-terminated, 2 inch microstrip trace on standard FR4 (1.5pF/inch). For best signal integrity, the series resistance of the transmission line should be matched closely to the selected RDSON of the I/O pad output driver.
- RGMII timing specifications are valid for both 1.8V and 3.3V nominal I/O pad supply voltage.
- For all versions prior to RGMII v2.0 specifications; This implies that PC board design will require clocks to be routed such that an additional delay of greater than 1.5 ns and less than 2 ns will be added to the associated clock signal. For 10/100, the max value is unspecified.
- Duty cycle may be stretched/shrunk during speed changes or while transitioning to a received packet's clock domain as long as minimum duty cycle is not violated and stretching occurs for no more than three T_{cy} of the lowest speed transitioned between.

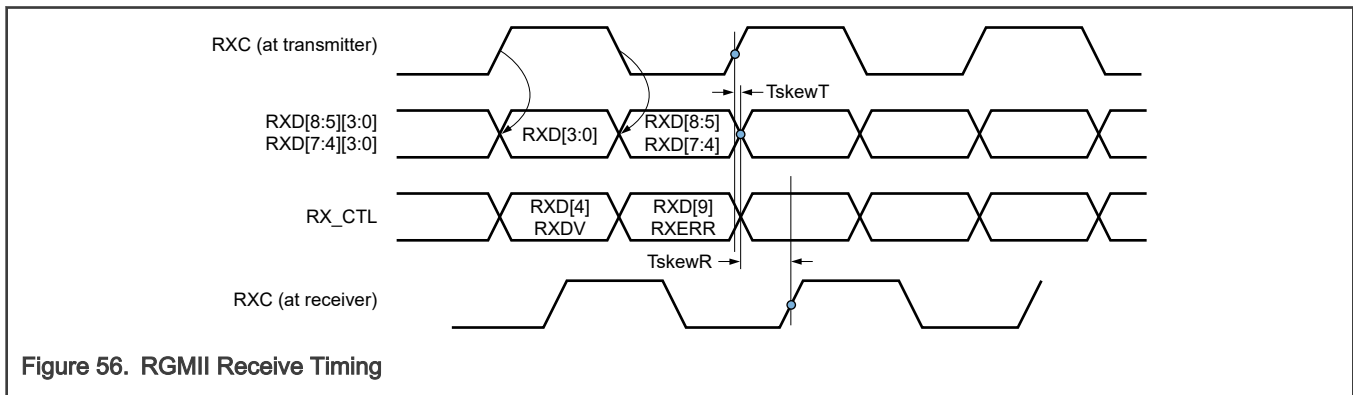

Figure 56. RGMII Receive Timing

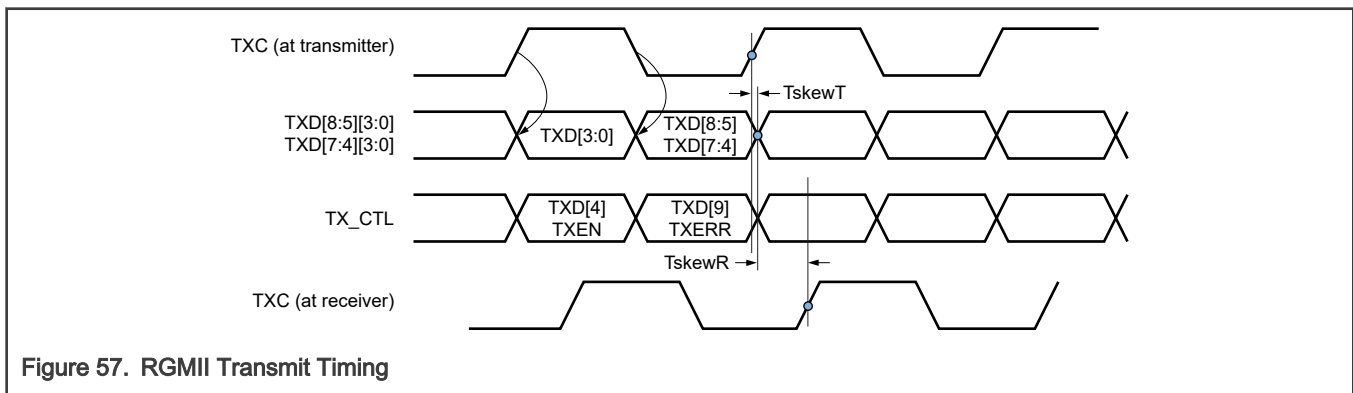

Figure 57. RGMII Transmit Timing

16.6.6 GMAC and PFE SGMII

Table 42. GMAC and PFE SGMII

Symbol	Description	Min	Typ	Max	Unit	Condition	Spec Number
UI	Unit Interval (mean)	799.92	800	800.08	ps	1.25 Gbps bit rate, applies to both transmitter and receiver and supports 1 Gbps data rate	—
UI	Unit Interval (mean)	319.968	320	320.032	ps	3.125 Gbps bit rate, applies to both transmitter and receiver and supports 2.5 Gbps data rate	—
trise	Transmit Vod rise time (20-80%)	—	—	100	ps	—	—
tfall	Transmit Vod fall time (20-80%)	—	—	100	ps	—	—
VOD	Transmit Output Differential Voltage	400	—	600	mV	1.25Gbps	—
VOD	Transmit Output Differential Voltage ¹	400	—	600	mV	3.125Gbps	—
RDOUT	Transmit Differential Output Impedance	80	100	120	Ohm	—	—
Dj	Transmit Deterministic Jitter	—	—	0.17	UI	—	—
Tj	Transmit Total Jitter	—	—	0.35	UI	—	—
RDIN	Receiver Differential Input Impedance	80	—	120	Ohm	—	—
VIN	Receiver Differential Input Voltage	200	—	1200	mV	—	—
LOS	Loss-of-signal threshold	75	—	200	mV	—	—
Sjt	Receiver deterministic jitter tolerance with sinusoidal noise ²	—	—	0.37	UI	—	—
DRjt	Receiver combined random and deterministic jitter tolerance with sinusoidal noise ²	—	—	0.55	UI	—	—
Tjt	Receiver total jitter tolerance	—	—	0.65	UI	—	—

Table continues on the next page...

Table 42. GMAC and PFE SGMII (continued)

Symbol	Description	Min	Typ	Max	Unit	Condition	Spec Number
BER	Bit Error Rate	—	—	10 ⁻¹²	—	—	—

- VOD at 3.125Gbps is only applicable for PFE_MAC0.
- The sinusoidal jitter in the total jitter tolerance may have any amplitude and frequency in the un-shaded region of the figure below.

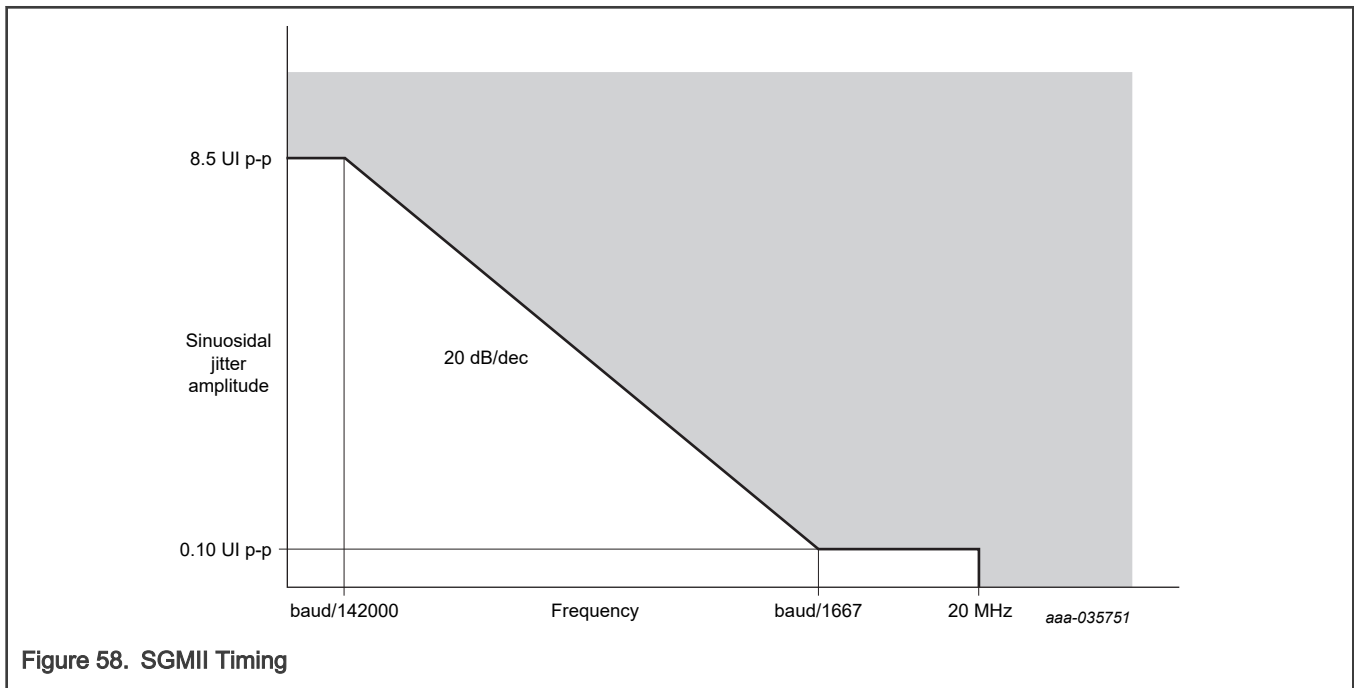

16.12 USB-ULPI

Table 43. USB-ULPI

Symbol	Description	Min	Typ	Max	Unit	Condition	Spec Number
TCLK	USB_CLKIN period	—	16.67	—	ns	—	U1
DFCLK	USB_CLKIN duty cycle	—	50	—	%	—	—
tISU	Input setup time (control and data) ¹	5	—	—	ns	—	U2
tIH	Input hold time (control and data) ¹	1	—	—	ns	—	U3
tOV	Output valid time (control and data) ²	—	—	9.5	ns	—	U4
tOH	Output hold time (control and data) ²	0	—	—	ns	—	U5

- Input timing assumes an input signal slew rate of 3ns (20%/80%).

- Output timing valid for maximum external load $CL = 25pF$, which is assumed to be a $10pF$ load at the end of a 50Ω , un-terminated, 5 inch microstrip trace on standard FR4 with $1.5pF/inch$ ($25pF$ total with margin). For best signal integrity, the series resistance of the transmission line should match closely to the $RDSON$ of the I/O pad output driver.

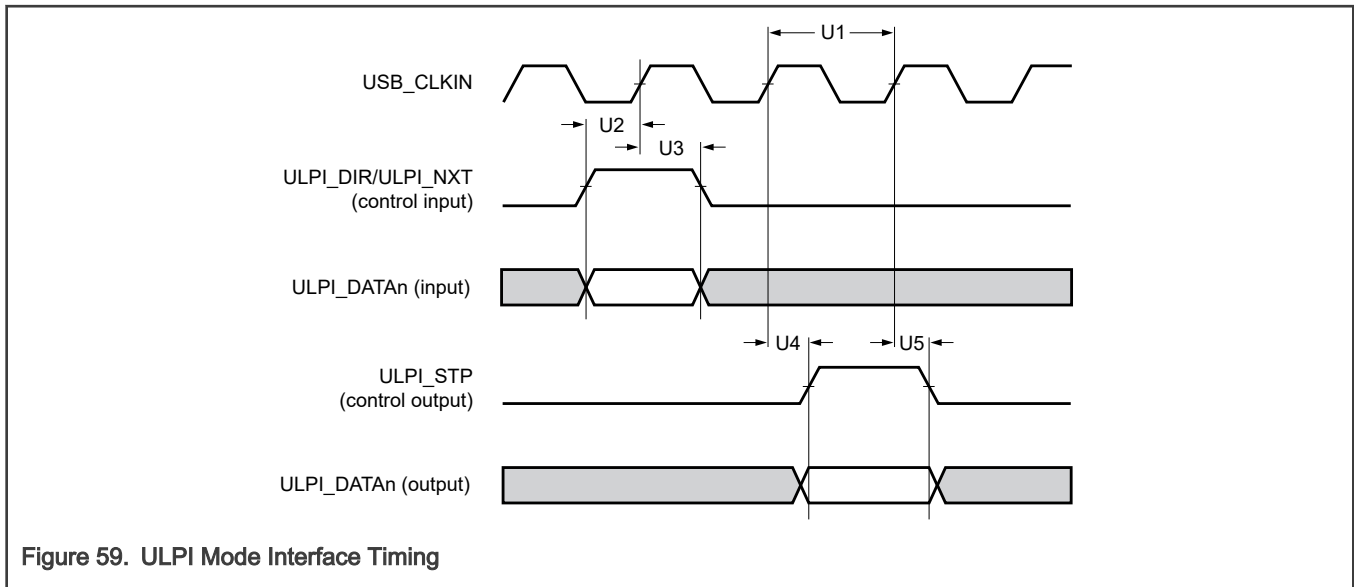

Figure 59. ULPI Mode Interface Timing

16.8 Memory interfaces

16.8.1 QuadSPI

An external resistor is needed to pull up a QuadSPI chip select signal.

16.8.2 QuadSPI Quad 1.8V DDR 66MHz

The $SRE[2:0]=100$ for 18GPIO pads and $SRE[2:0]=101$ for 1833Fast pads is the required drive setting to meet the timing.

$FLSHCR[TCSS]$ and $FLSHCR[TCSH]$ should be set to 3.

All transitions measured at mid-supply ($VDD_{IO_QSPI}/2$).

Table 44. QuadSPI Quad 1.8V DDR 66MHz

Symbol	Description	Min	Typ	Max	Unit	Condition	Spec Number
fSCK	SCK clock frequency ^{1,2}	—	—	66	MHz	DLL mode enabled	—
tCL_SCK	SCK clock low time ^{1,2}	6.818	—	—	ns	—	—
tCH_SCK	SCK clock high time ^{1,2}	6.818	—	—	ns	—	—
tOD_DATA	Data output delay (w.r.t. SCK) ¹	2.316	—	4.802	ns	—	—
tOD_CS	CS output delay (w.r.t. SCK) ^{1,3}	$5.016 - n/fSCK$	—	$1.802 + m/fSCK$	ns	—	—

Table continues on the next page...

Table 44. QuadSPI Quad 1.8V DDR 66MHz (continued)

Symbol	Description	Min	Typ	Max	Unit	Condition	Spec Number
tDVW	Input data valid window ²	5.14	—	—	ns	—	—
tLSKEW	Skew target for Auto-learning mode ⁴	1.89	—	—	ns	—	—

- Output timing valid for maximum external load CL = 20pF, which is assumed to be a 10pF-15pF load at the end of a 50ohm, un-terminated, 2 inch microstrip trace on standard FR4 (1.5pF/inch). For best signal integrity, the series resistance in the transmission line should be matched closely to the selected RDSON of the I/O pad output.
- Input timing assumes maximum input signal transition of 1ns (20%/80%).
- Where m=TCSS and n=TCSH-1.
- Data valid window includes DLL Margin, and determines LEARNING skew targets which can be more pessimistic than tISU_SCK and tIH_SCK.

16.8.3 QuadSPI Octal 1.8V SDR 133MHz

The SRE[2:0]=100 for 18GPIO pads and SRE[2:0]=101 for 1833Fast pads is the required drive setting to meet the timing.

FLSHCR[TCSS] and FLSHCR[TCSH] should be set to 3.

All transitions measured at mid-supply (VDD_IO_QSPI/2).

Table 45. QuadSPI Octal 1.8V SDR 133MHz

Symbol	Description	Min	Typ	Max	Unit	Condition	Spec Number
fSCK	SCK clock frequency ^{1,2}	—	—	133	MHz	DLL mode enabled	—
tCL_SCK	SCK clock low time ^{1,2}	3.383	—	—	ns	—	—
tCH_SCK	SCK clock high time ^{1,2}	3.383	—	—	ns	—	—
tOD_DATA	Data output delay (w.r.t. SCK) ¹	-1.594	—	1.594	ns	—	—
tOD_CS	CS output delay (w.r.t. SCK) ^{1,3}	3.016 - n/fSCK	—	2.704 + m/fSCK	ns	—	—
tISU_SCK	Input setup time (w.r.t. SCK) ²	0.580	—	—	ns	—	—
tIH_SCK	Input hold time (w.r.t. SCK) ²	0.9	—	—	ns	—	—

- Output timing valid for maximum external load CL = 20pF, which is assumed to be a 10pF-15pF load at the end of a 50ohm, un-terminated, 2 inch microstrip trace on standard FR4 (1.5pF/inch). For best signal integrity, the series resistance in the transmission line should be matched closely to the selected RDSON of the I/O pad output.
- Input timing assumes maximum input signal transition of 1ns (20%/80%).
- Where m=TCSS and n=TCSH-1.

16.8.4 QuadSPI Octal 1.8V DDR 100MHz

The information in this section applies to Octal- and Hyperflash.

The SRE[2:0]=100 for 18GPIO pads and SRE[2:0]=101 for 1833Fast pads is the required drive setting to meet the timing.

FLSHCR[TCSS] and FLSHCR[TCSH] should be set to 3.

All transitions measured at mid-supply (VDD_IO_QSPI/2).

Table 46. QuadSPI Octal 1.8V DDR 100MHz

Symbol	Description	Min	Typ	Max	Unit	Condition	Spec Number
fSCK_DQS	SCK / DQS frequency ^{1,2}	—	—	100	MHz	fSCK duty cycle distortion is in the range of 45%-55%.	—
tCL_SCK	SCK low time ^{1,2}	4.500	—	—	ns	—	—
tCH_SCK	SCK high time ^{1,2}	4.500	—	—	ns	—	—
tOD_DATA	Data output delay (w.r.t. SCK) ²	1.016	—	3.484	ns	—	—
tOD_CS	CS output delay (w.r.t. SCK) ^{2,3}	3.016 - n/ fSCK	—	-0.016 + m/fSCK	ns	—	—
tISU_DQS	Input setup time (w.r.t. DQS) ¹	-0.816	—	—	ns	—	—
tIH_DQS	Input hold time (w.r.t. DQS) ¹	3.684	—	—	ns	—	—

1. Input timing assumes maximum input signal transition of 1 ns (20%/80%). DQS denotes external strobe provided by the Flash.
2. Output timing valid for maximum external load CL = 20pF, which is assumed to be a 10pF-15pF load at the end of a 50ohm, un-terminated, 2 inch microstrip trace on standard FR4 (1.5pF/inch). For best signal integrity, the series resistance in the transmission line should be matched closely to the selected RDSO of the I/O pad output.
3. Where m=TCSS and n=TCSH-1.

16.8.5 QuadSPI Octal 1.8V DDR 133MHz

The information in this section applies to Octal- and Hyperflash.

The SRE[2:0]=100 for 18GPIO pads and SRE[2:0]=101 for 1833Fast pads is the required drive setting to meet the timing.

FLSHCR[TCSS] and FLSHCR[TCSH] should be set to 3.

All transitions measured at mid-supply (VDD_IO_QSPI/2).

Table 47. QuadSPI Octal 1.8V DDR 133MHz

Symbol	Description	Min	Typ	Max	Unit	Condition	Spec Number
fSCK_DQS	SCK / DQS frequency ^{1,2}	—	—	133	MHz	DLL mode enabled, fSCK duty cycle distortion is in the range of 45%-55%.	—
tCL_SCK	SCK low time ^{1,2}	3.383	—	—	ns	—	—
tCH_SCK	SCK high time ^{1,2}	3.383	—	—	ns	—	—

Table continues on the next page...

Table 47. QuadSPI Octal 1.8V DDR 133MHz (continued)

Symbol	Description	Min	Typ	Max	Unit	Condition	Spec Number
tOD_DATA	Data output delay (w.r.t. SCK) ²	0.816	—	2.567	ns	—	—
tOD_CS	CS output delay (w.r.t. SCK) ^{2,3}	3.015 - n/ fSCK	—	-1.33 + m/fSCK	ns	—	—
tISU_DQS	Input setup time (w.r.t. DQS) ¹	-0.616	—	—	ns	—	—
tIH_DQS	Input hold time (w.r.t. DQS) ¹	2.767	—	—	ns	—	—

- Input timing assumes maximum input signal transition of 1 ns (20%/80%). DQS denotes external strobe provided by the Flash.
- Output timing valid for maximum external load CL = 20pF, which is assumed to be a 12pF-15pF load at the end of a 50ohm, un-terminated, 2 inch microstrip trace on standard FR4 (1.5pF/inch). For best signal integrity, the series resistance in the transmission line should be matched closely to the selected RDSON of the I/O pad output.
- Where m=TCSS and n=TCSH-1.

16.8.6 QuadSPI Octal 1.8V SDR 100MHz

The SRE[2:0]=100 for 18GPIO pads and SRE[2:0]=101 for 1833Fast pads is the required drive setting to meet the timing.

FLSHCR[TCSS] and FLSHCR[TCSH] should be set to 3.

All transitions measured at mid-supply (VDD_IO_QSPI/2).

Table 48. QuadSPI Octal 1.8V SDR 100MHz

Symbol	Description	Min	Typ	Max	Unit	Condition	Spec Number
fSCK	SCK clock frequency ^{1,2}	—	—	100	MHz	—	—
tCL_SCK	SCK clock low time ^{1,2}	4.5	—	—	ns	—	—
tCH_SCK	SCK clock high time ^{1,2}	4.5	—	—	ns	—	—
tOD_DATA	Data output delay (w.r.t. SCK) ²	-2.822	—	2.822	ns	—	—
tOD_CS	CS output delay (w.r.t. SCK) ^{2,3}	3.016 - n/ fSCK	—	5.160 + m/fSCK	ns	—	—
tISU_SCK	Input setup time (w.r.t. SCK) ¹	3.036	—	—	ns	—	—
tIH_SCK	Input hold time (w.r.t. SCK) ¹	0.9	—	—	ns	—	—

- Input timing assumes an input signal transition of 1ns (20%/80%).
- Output timing valid for maximum external load CL = 20pF, which is assumed to be a 10pF-15pF load at the end of a 50ohm, un-terminated, 2 inch microstrip trace on standard FR4 (1.5pF/inch). For best signal integrity, the series resistance of the transmission line should be matched closely to the selected RDSON of the I/O pad output driver.
- Where m=TCSS and n=TCSH-1.

16.8.7 QuadSPI Quad 1.8V SDR 133MHz

The SRE[2:0]=100 for 18GPIO pads and SRE[2:0]=101 for 1833Fast pads is the required drive setting to meet the timing.

FLSHCR[TCSS] and FLSHCR[TCSH] should be set to 3.

All transitions measured at mid-supply (VDD_IO_QSPI/2).

Table 49. QuadSPI Quad 1.8V SDR 133MHz

Symbol	Description	Min	Typ	Max	Unit	Condition	Spec Number
fSCK	SCK clock frequency ^{1,2}	—	—	133	MHz	DLL mode enabled	—
tCL_SCK	SCK low time ^{1,2}	3.383	—	—	ns	—	—
tCH_SCK	SCK high time ^{1,2}	3.383	—	—	ns	—	—
tOD_DATA	Data output delay (w.r.t. SCK) ¹	-0.594	—	1.594	ns	—	—
tOD_CS	CS output delay (w.r.t. SCK) ^{1,3}	4.016 - n/fSCK	—	4.204 + m/fSCK	ns	—	—
tISU_SCK	Input setup time (w.r.t. SCK) ²	0.580	—	—	ns	—	—
tIH_SCK	Input hold time (w.r.t. SCK) ²	1.000	—	—	ns	—	—

1. Output timing valid for maximum external load CL = 20pF, which is assumed to be a 10pF-15pF load at the end of a 50ohm, un-terminated, 2 inch microstrip trace on standard FR4 (1.5pF/inch). For best signal integrity, the series resistance in the transmission line should be matched closely to the selected RDSON of the I/O pad output.
2. Input timing assumes maximum input signal transition of 1ns (20%/80%).
3. Where m=TCSS and n=TCSH-1.

16.8.8 QuadSPI Quad 3.3V DDR 66MHz

The SRE[2:0]=100 for 18GPIO pads and SRE[2:0]=101 for 1833Fast pads is the required drive setting to meet the timing.

FLSHCR[TCSS] and FLSHCR[TCSH] should be set to 3.

All transitions measured at mid-supply (VDD_IO_QSPI/2).

Table 50. QuadSPI Quad 3.3V DDR 66MHz

Symbol	Description	Min	Typ	Max	Unit	Condition	Spec Number
fSCK	SCK clock frequency ^{1,2}	—	—	66	MHz	DLL mode enabled	—
tCL_SCK	SCK clock low time ^{1,2}	6.818	—	—	ns	—	—
tCH_SCK	SCK clock high time ^{1,2}	6.818	—	—	ns	—	—
tOD_DATA	Data output delay (w.r.t. SCK) ¹	2.316	—	4.802	ns	—	—

Table continues on the next page...

Table 50. QuadSPI Quad 3.3V DDR 66MHz (continued)

Symbol	Description	Min	Typ	Max	Unit	Condition	Spec Number
tOD_CS	CS output delay (w.r.t. SCK) ^{1,3}	5.016 - n/fSCK	—	1.802 + m/fSCK	ns	—	—
tDVW	Input data valid window ²	5.14	—	—	ns	—	—
tLSKEW	Skew target for Auto-learning mode ⁴	1.89	—	—	ns	—	—

1. Output timing valid for maximum external load CL = 20pF, which is assumed to be a 10pF-15pF load at the end of a 50ohm, un-terminated, 2 inch microstrip trace on standard FR4 (1.5pF/inch). For best signal integrity, the series resistance in the transmission line should be matched closely to the selected RDSON of the I/O pad output.
2. Input timing assumes maximum input signal transition of 1ns (20%/80%).
3. Where m=TCSS and n=TCSH-1.
4. Data valid window includes DLL Margin, and determines LEARNING skew targets which can be more pessimistic than tISU_SCK and tIH_SCK..

16.8.9 QuadSPI Quad 3.3V SDR 104MHz

The SRE[2:0]=100 for 18GPIO pads and SRE[2:0]=101 for 1833Fast pads is the required drive setting to meet the timing.

FLSHCR[TCSS] and FLSHCR[TCSH] should be set to 3.

All transitions measured at mid-supply (VDD_IO_QSPI/2).

Table 51. QuadSPI Quad 3.3V SDR 104MHz

Symbol	Description	Min	Typ	Max	Unit	Condition	Spec Number
fSCK	SCK clock frequency ^{1,2}	—	—	104	MHz	—	—
tCL_SCK	SCK clock low time ^{1,2}	4.327	—	—	ns	—	—
tCH_SCK	SCK clock high time ^{1,2}	4.327	—	—	ns	—	—
tOD_DATA	Data output delay (w.r.t. SCK) ¹	-2.330	—	2.880	ns	—	—
tOD_CS	CS output delay (w.r.t. SCK) ^{1,3}	3.391 - n/fSCK	—	5.901 + m/fSCK	ns	—	—
tISU_SCK	Input setup time (w.r.t. SCK) ²	2.152	—	—	ns	—	—
tIH_SCK	Input hold time (w.r.t. SCK) ²	2.0	—	—	ns	—	—

1. Timing valid for maximum external load CL = 20pF, which is assumed to be a 10pF-15pF load at the end of a 50ohm, un-terminated, 2 inch microstrip trace on standard FR4 (1.5pF/inch). For best signal integrity, the series resistance of the transmission line should be matched closely to the selected RDSON of the I/O pad output driver.
2. Input timing assumes maximum input signal transition of 1ns (20%/80%).
3. Where m=TCSS and n=TCSH-1.

16.8.10 QuadSPI Octal 1.8V DDR 166MHz

The information in this section applies to Octal- and Hyperflash.

The SRE[2:0]=000 for 18GPIO pads is the required drive setting to meet the timing.

FLSHCR[TCSS] and FLSHCR[TCSH] should be set to 3.

Data transitions measured at 30%/70% supply for the write path. Data transitions measured at mid-supply for the read path. Clock transitions measured at mid-supply

Table 52. QuadSPI Octal 1.8V DDR 166MHz

Symbol	Description	Min	Typ	Max	Unit	Condition	Spec Number
fSCK-DQS	SCK/DQS frequency ^{1,2}	—	—	166	MHz	fSCK duty cycle distortion is in the range of 45%-55%.	—
tCL_SCK	SCK low time ^{1,2}	2.711	—	—	ns	—	—
tCH_SCK	SCK high time ^{1,2}	2.711	—	—	ns	—	—
tOD_DATA	Data output delay (w.r.t. SCK) ¹	0.616	—	2.095	ns	—	—
tOD_CS	CS output delay (w.r.t. SCK) ^{1,3}	3.016 - n/fSCK	—	-1.805 + m/fSCK	ns	—	—
tIH_DQS	Input hold time (w.r.t. DQS) ²	2.105	—	—	ns	—	—
tISU_DQS	Input setup time (w.r.t. DQS) ²	-0.616	—	—	ns	—	—

- Output timing valid for maximum external load CL = 20pF, which is assumed to be a 12pF-15pF load at the end of a 50ohm, un-terminated, 2 inch microstrip trace on standard FR4 (1.5pF/inch). For best signal integrity, the series resistance in the transmission line should be matched closely to the selected RDSON of the I/O pad output.
- Input timing assumes maximum input signal transition of 1 ns (20%/80%). DQS denotes external strobe provided by the Flash.
- Where m=TCSS and n=TCSH-1.

16.8.11 QuadSPI Octal 1.8V DDR 200MHz

In Single SRE configuration SRE[2:0]=000 for Data & CLK both, and in Split SRE configuration SRE[2:0]=000 for Data & SRE[2:0]=110 for CLK are the required drive settings to meet the timing for 18GPIO pad.

FLSHCR[TCSS] and FLSHCR[TCSH] should be set to 3.

Data transitions measured at 30%/70% supply for the write path. Data transitions measured at mid-supply for the read path. Clock transitions measured at mid-supply

Table 53. QuadSPI Octal 1.8V DDR 200MHz

Symbol	Description	Min	Typ	Max	Unit	Condition	Spec Number
fSCK-DQS	SCK/DQS frequency ^{1,2}	—	—	200	MHz	fSCK duty cycle distortion is in the range of 45%-55%.	—
tCL_SCK	SCK low time ^{1,2}	2.25	—	—	ns	—	—

Table continues on the next page...

Table 53. QuadSPI Octal 1.8V DDR 200MHz (continued)

Symbol	Description	Min	Typ	Max	Unit	Condition	Spec Number
tCH_SCK	SCK high time ^{1,2}	2.25	—	—	ns	—	—
tOD_DATA	Data output delay (w.r.t. SCK) ¹	0.616	—	1.634	ns	Split SRE configuration, SRE[2:0]=000 for Data and SRE[2:0]=110 for CLK	—
tOD_DATA	Data output delay (w.r.t. SCK) ¹	0.772	—	1.79	ns	Single SRE configuration, SRE[2:0]=000	—
tOD_CS	CS output delay (w.r.t. SCK) ^{1,3}	3.016 - n/fSCK	—	-2.266 + m/fSCK	ns	—	—
tIH_DQS	Input hold time (w.r.t. DQS) ²	1.644	—	—	ns	—	—
tISU_DQS	Input setup time (w.r.t. DQS) ²	-0.586	—	—	ns	—	—

1. Output timing valid for maximum external load CL = 20pF, which is assumed to be a 12pF-15pF load at the end of a 50ohm, un-terminated, 2 inch microstrip trace on standard FR4 (1.5pF/inch). For best signal integrity, the series resistance in the transmission line should be matched closely to the selected RDSON of the I/O pad output.
2. Input timing assumes maximum input signal transition of 1 ns (20%/80%). DQS denotes external strobe provided by the Flash.
3. Where m=TCSS and n=TCSH-1.

16.8.12 QuadSPI configurations

The below table shows a subset of the QuadSPI module configurations for different speeds and data rates. The configuration values for each case are equally applicable to Quad, Octal and HyperFlash interfaces, so long as the maximum clock frequency as per [Table 55](#) is not exceeded.

Table 54. QuadSPI configurations

-	DDR-200MHz	DDR-133MHz	SDR-133MHz	SDR-104MHz	DDR-66MHz
DQS mode	External DQS Edge Aligned	External DQS Edge Aligned	Internal pad loopback	Internal pad loopback	Internal pad loopback
Sampling mode	DDR	DDR	SDR	SDR	DDR
DLL Mode	DLL Enable	DLL Enable	DLL Bypass	DLL Bypass	DLL Enable
Data Learning	No	No	No	No	Yes
IO Voltage	1.8V	1.8V	1.8V	3.3V	1.8V/3.3V
Frequency	166/200 MHz	100/133 MHz	100/133 MHz	104 MHz	66 MHz
FLSHCR[TDH]	1	1	0	0	1
FLSHCR[TCSH]	3	3	3	3	3

Table continues on the next page...

Table 54. QuadSPI configurations (continued)

-	DDR-200MHz	DDR-133MHz	SDR-133MHz	SDR-104MHz	DDR-66MHz
FLSHCR[TCSS]	3	3	3	3	3
MCR[DLPEN]	0	0	0	0	1
DLLCR[DLEN]	1	1	0	0	1
DLLCR[FREQEN]	1	0	0	0	0
DLLCR[DLL_REFCNTR]	2	2	NA	NA	2
DLLCR[DLLRES]	8	8	NA	NA	8
DLLCR[SLV_FINE_OFFSET]	0	0	0	0	0
DLLCR[SLV_DLY_OFFSET]	0	0	0	0	3
DLLCR[SLV_DLY_COARSE]	NA	NA	0	0	0
DLLCR[SLAVE_AUTO_UPDT]	1	1	0	0	1
DLLCR[SLV_EN]	1	1	1	1	1
DLLCR[SLV_DLL_BYPASS]	0	0	1	1	0
DLLCR[SLV_UPD]	1	1	1	1	1
SMPR[DLLFSMPF]	3 (200 Mhz) 4 (166 Mhz)	4	0	0	NA
SMPR[FSDLY]	0	0	0	0	1
SMPR[FSPHS]	NA	NA	1	1	NA

16.8.13 QuadSPI interfaces

The QuadSPI module supports 2 interfaces; QSPI A & QSPI B. These interfaces are not independent & the QSPI chapter of the reference manual should be consulted for their usage. The table below summarizes which specifications are supported on each interface.

Table 55. QuadSPI interfaces

Specification / Interface	3.3V Quad	1.8V Quad	1.8V Octal	1.8V Hyperflash
QSPI A	n/a	SDR 100/133MHz DDR 66MHz	SDR 100/133MHz DDR 100/133/166/200 MHz	DDR 100/133/166 MHz
QSPI B	SDR 104MHz DDR 66MHz	SDR 100/133MHz DDR 66MHz	SDR 100/133MHz DDR 100/133MHz	DDR 100/133MHz

16.8.14 QuadSPI timing diagrams

The sections shows the QuadSPI timing diagrams for all modes supported by the device. All data is based on a negative edge data launch from the device.

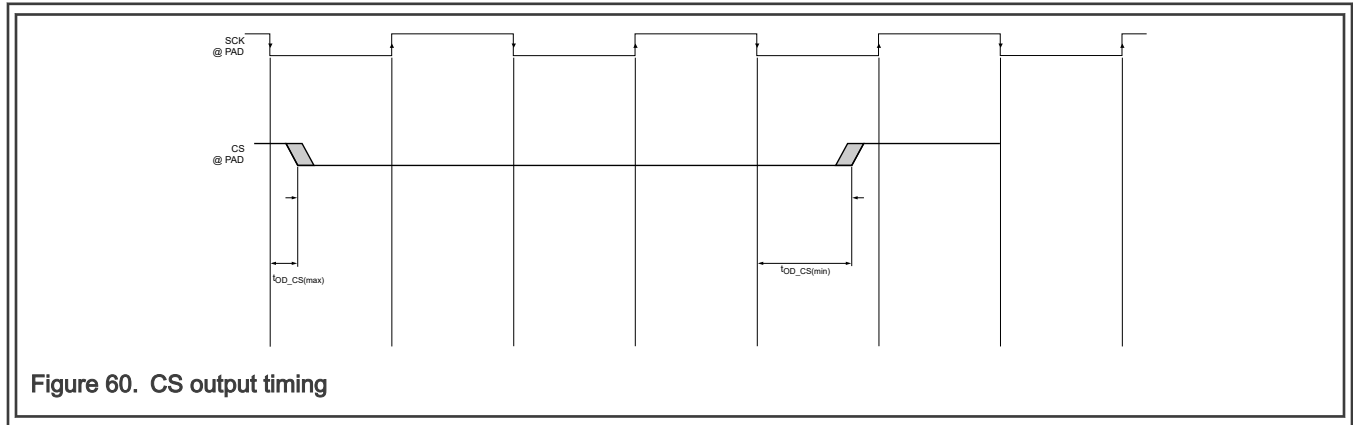

Figure 60. CS output timing

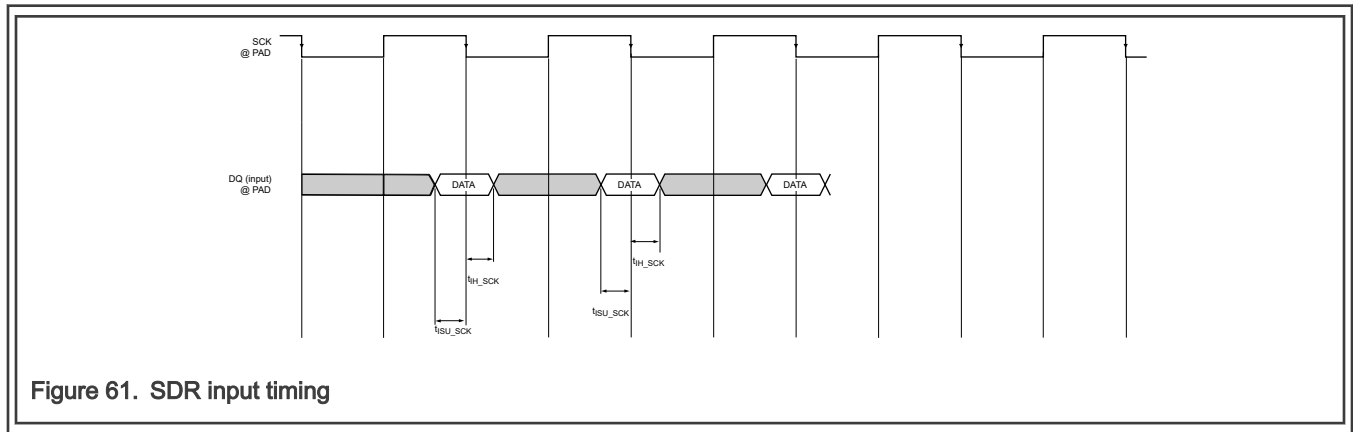

Figure 61. SDR input timing

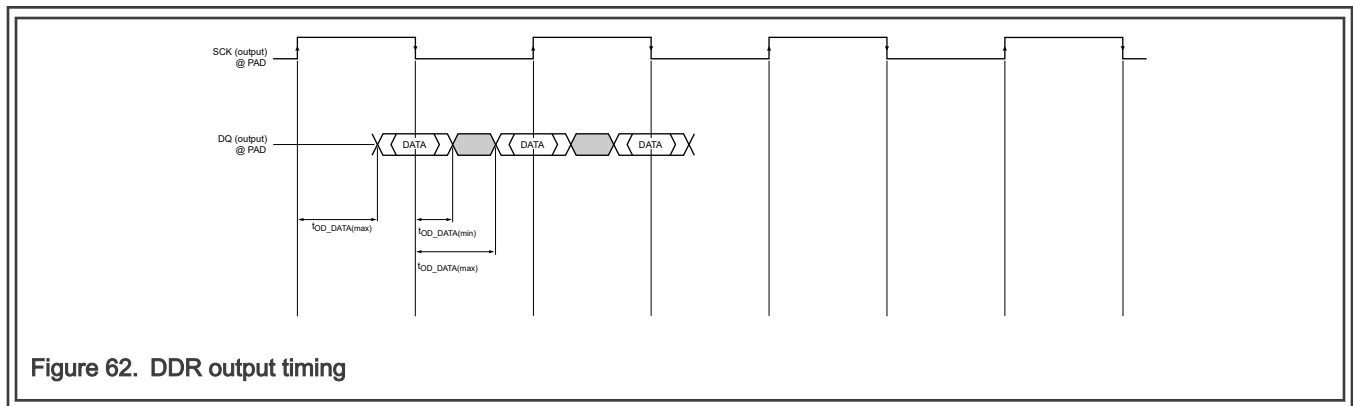

Figure 62. DDR output timing

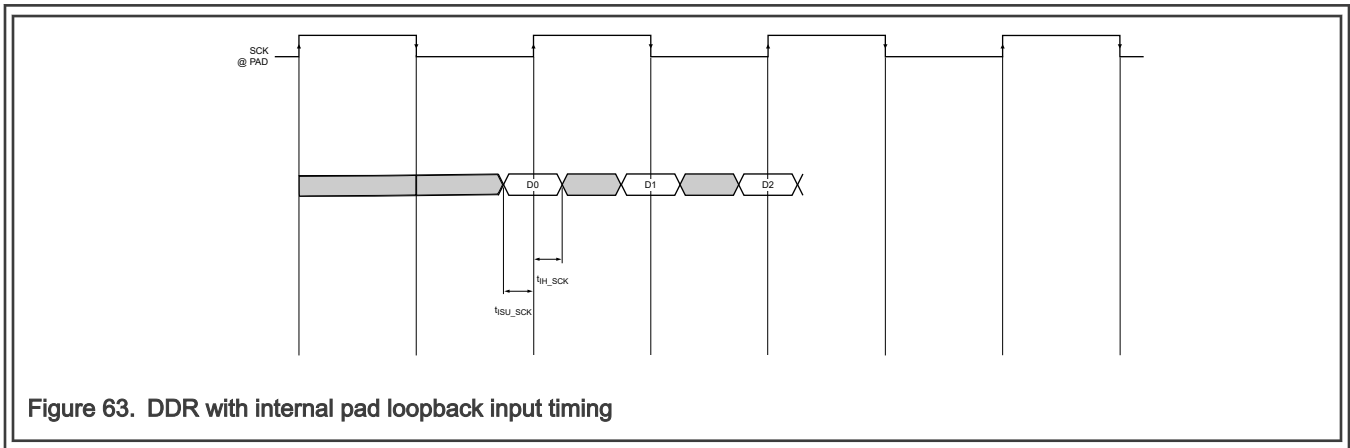

Figure 63. DDR with internal pad loopback input timing

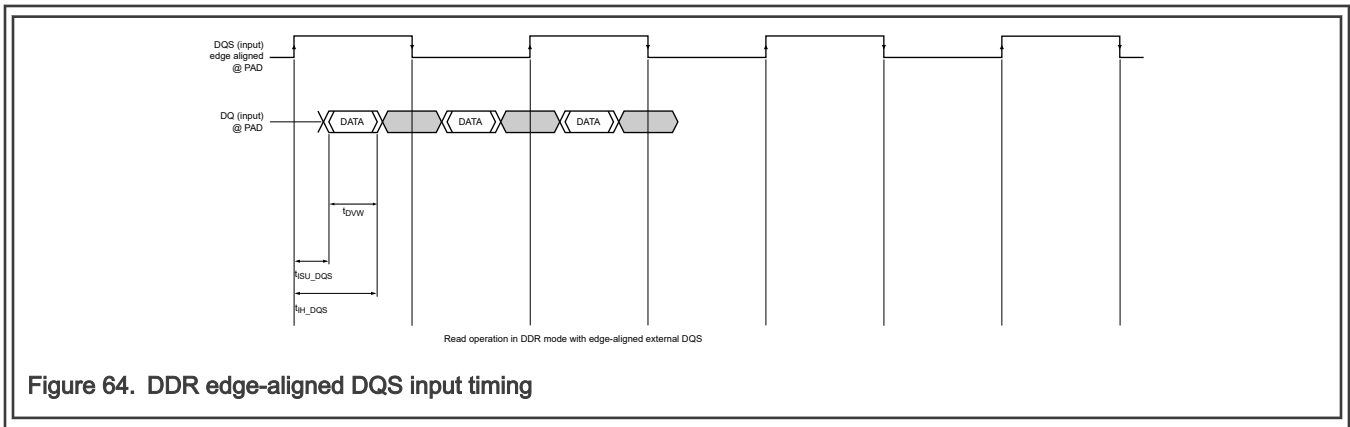

Figure 64. DDR edge-aligned DQS input timing

16.9 DDR

16.9.1 DDR

The chip supports the following memory types:

1. LPDDR4 SDRAM compliant to JEDEC209-4B LPDDR4 JEDEC standard release.
2. DDR3L SDRAM compliant to JESD79-3-1A DDR3L JEDEC standard release July, 2010.

DDR operation with the standards stated above is contingent upon the board DDR design adherence to the DDR design and layout requirements stated in the chip's Hardware Design Guide Document.

LPDDR4 routing constraints are documented in the chip's Hardware Design Guidelines Document.

16.9.2 DDR Common DC Input

The specifications given in the table below represent the common DC input conditions for all DDR interface modes. Unless otherwise specified, all input specifications (both common and DDR standard specific) are measured at the host PHY input pins. Subsequent sections list input parameters for the specific memory interface standards.

Table 56. DDR Common DC Input

Symbol	Description	Min	Typ	Max	Unit	Condition	Spec Number
IIZ-VREF	VREF input leakage current ¹	-50	—	50	uA	—	—
IIZ-BP	Input leakage current ²	-50	—	50	uA	—	—
VIH-DC_BPDAT	Input high voltage threshold	VREF+0.085	—	—	V	—	—
VIL-DC_BPDAT	Input low voltage threshold	—	—	vref - 0.085	V	—	—

1. Leakage is valid for Vref over the range $0 \leq V_{IN} \leq V_{DD_IO_DDR0}$, with Vref input function enabled. All pins not under test = VDD_IO_DDR0.
2. Leakage current is measured when the pin is configured to a high-impedance state with all on-die termination disabled. Leakage is valid for any input except for Vref over the range: $0 \leq V_{IN} \leq V_{DD_IO_DDR0}$. All pins not under test = VSS or VDD_IO_DDR0.

16.9.3 DDR Common DC Output

Table 57. DDR Common DC Output

Symbol	Description	Min	Typ	Max	Unit	Condition	Spec Number
ROnPu	Output driver pull-up impedance: DQ, DQS outputs ¹	—	120,60,40	—	Ohm	—	—
ROnPd	Output driver pull-down impedance: DQ, DQS outputs ¹	—	120,60,40	—	Ohm	—	—
ROnPu	Output driver pull-up impedance: address, command ¹	—	120,60,40	—	Ohm	—	—
ROnPd	Output driver pull-down impedance: address, command ¹	—	120,60,40	—	Ohm	—	—
ROnPu	Output driver pull-up impedance: DDR0_RESET_B, CKE outputs ²	—	18-28	—	Ohm	—	—
ROnPd	Output driver pull-down impedance: DDR0_RESET_B, CKE outputs ²	—	18-28	—	Ohm	—	—

1. Calibrated at $V_{DD_IO_DDR0} / 2$.
2. For the DDR0_RESET_B pin and CKE pin, the driver is in maximum strength and impedance value is process dependent.

NOTE: Refer to IBIS model for the complete IV curve characteristics.

16.9.4 DDR3L DC Input

Table 58. DDR3L DC Input

Symbol	Description	Min	Typ	Max	Unit	Condition	Spec Number
Vref	Input reference voltage ^{1,2}	30.1	31.1	32.1	%VDD_I O_DDR	—	—

- Externally supplied Vref is not recommended. Internal Vref generation through local Vref generation at each receiver is preferred.
- If the external Vref to the receivers is enabled, DDR0_VREF is expected to be set to a nominal value of $(VDD_IO_DDR0/2) * RxAtten$ (RxAttenuation for DDR3L is 0.623) through a voltage divider in order to track VDD_IO_DDR0 level. It can be adjusted in the system to margin the input DQ signals, although this margin does not necessarily represent the eye height since a change in Vref also changes the input receiver common mode, altering receiver performance.

16.9.5 DDR3L Output Timing

Table 59. DDR3L Output Timing

Symbol	Description	Min	Typ	Max	Unit	Condition	Spec Number
tCK(avg)	Average clock period ^{1,2}	—	1.25	—	ns	—	—
tOS(Vref)	Command and address setup time to CK (to Vref levels) ^{1,2}	350	—	—	ps	—	—
tOH(Vref)	Command and address hold time to CK (to Vref levels) ^{1,2}	350	—	—	ps	—	—
tDOeye	Output data eye ^{1,2}	0.6	—	—	UI	—	—

- All measurements are in reference to the Vref level.
- Measurements were done with signals terminated with a 50ohm resistor terminated to VDD_IO_DDR0/2, Phy output is calibrated to a drive strength of 40ohms. Slew rate AtxSlewRate was set to 0x3FF (PreDrvMode=3, PreN=F,PreP=F); TxSlewRate was set 0x3FF (PreDrvMode=3, PreN=F,PreP=F).

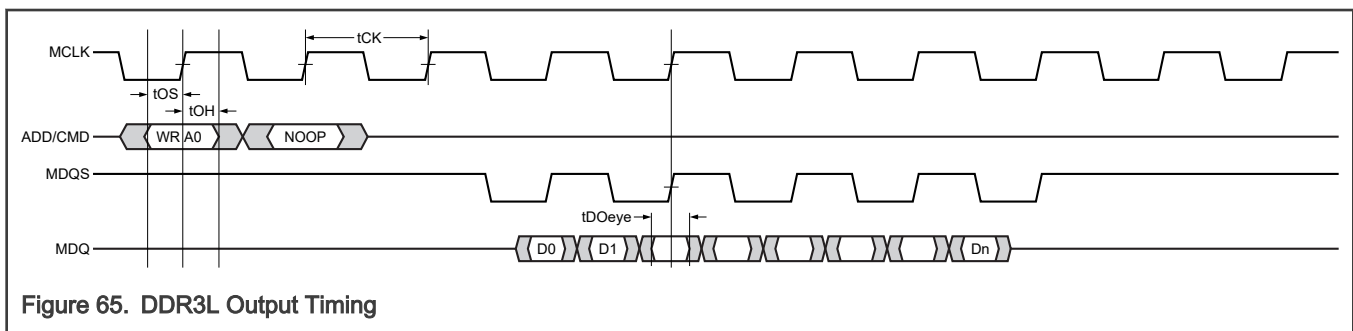

Figure 65. DDR3L Output Timing

16.9.6 LPDDR4 DC Input timing

Table 60. LPDDR4 DC Input timing

Symbol	Description	Min	Typ	Max	Unit	Condition	Spec Number
Vref	Internal reference voltage ^{1,2}	—	Variable	—	V	—	—

1. Because termination at the DRAMs is configurable, there is no fixed setting. The Vref value is dependent on driver impedance Ron and system effective ODT impedance Rtt.
2. Externally supplied Vref is not recommended. Internal Vref generation through local Vref generation at each receiver is preferred.

16.9.7 LPDDR4 Output Timing

Table 61. LPDDR4 Output Timing

Symbol	Description	Min	Typ	Max	Unit	Condition	Spec Number
tCK(avg)	Average clock period ¹	—	0.625	—	ns	—	—
tDOeye	Output data eye ^{1,2,3}	0.55	—	—	UI	—	—
tCAOeye	CA output data eye ^{1,4}	0.62	—	—	UI	UI=625ps	—

1. Measurements were done with signals terminated with a 50ohm resistor terminated to VSS, Phy output is calibrated to a drive strength of 40ohms. Slew rate AtxSlewRate was set to 0x1FF (PreDrvMode=1, PreN=F,PreP=F); TxSlewRate was set 0x1FF (PreDrvMode=1, PreN=F, PreP=F).
2. tDOeye is trained to be shifted min 200 ps from DQS edge (tDQS2DQ learning).
3. Tx DQS to MCLK edges are trained to be aligned.
4. Addr/Cmd is centered aligned by training.

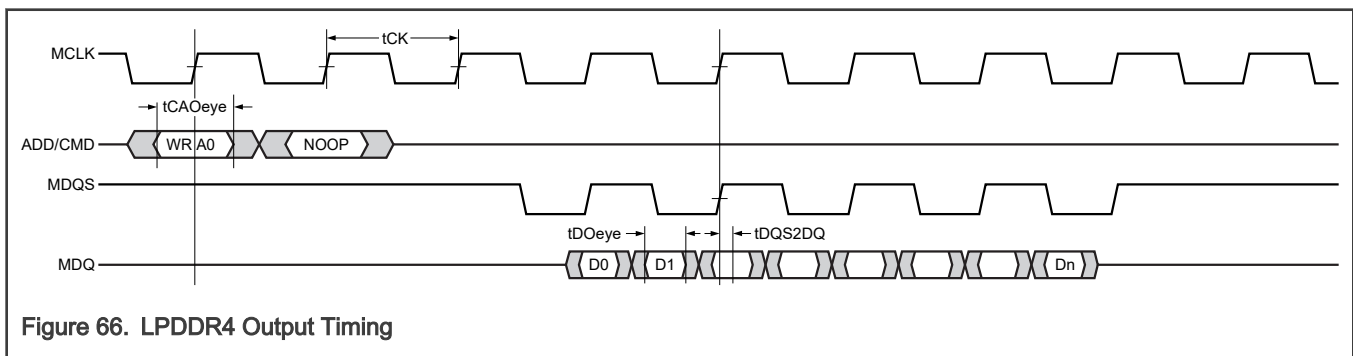

Figure 66. LPDDR4 Output Timing

16.10 uSDHC

16.10.1 uSDHC SD3.0/eMMC5.1 DDR

The SRE[2:0]=101 is required drive setting to meet the timing.

All uSDHC parameters are measured at mid-supply (VDD_IO_SDHC/2).

Table 62. uSDHC SD3.0/eMMC5.1 DDR

Symbol	Description	Min	Typ	Max	Unit	Condition	Spec Number
fpp	Clock frequency (eMMC5.1 DDR) ¹	—	—	52	MHz	—	SD1
fpp	Clock frequency (SD3.0 DDR) ¹	—	—	50	MHz	—	SD1
tWL	Clock low time	8.8	—	—	ns	—	—
tWH	Clock high time	8.8	—	—	ns	—	—
tTLH	Clock rise time ^{1,2}	—	—	0.8	ns	—	—
tTHL	Clock fall time ^{1,2}	—	—	0.8	ns	—	—
tOD	SDHC output delay (output valid) ¹	2.7	—	5.6	ns	SDHC_CLK to SDHC_DAT	SD2
tOD	SDHC output delay (output valid) ¹	-5.6	—	2.6	ns	SDHC_CLK to SDHC_CMD	SD6 (See SDR-52 MHz figure)
tISU	SDHC Input setup time ³	1.6	—	—	ns	SDHC_DAT to SDHC_CLK	SD3
tISU	SDHC Input setup time ³	4.8	—	—	ns	SDHC_CMD to SDHC_CLK	SD7 (See SDR-52 MHz figure)
tIH	SDHC Input hold time ³	1.5	—	—	ns	SDHC_CLK to SDHC_DAT	SD4
tIH	SDHC Input hold time ³	1.5	—	—	ns	SDHC_CLK to SDHC_CMD	SD8 (See SDR-52 MHz figure)

- Output timing valid for maximum external load CL = 25pF, which is assumed to be a 10pF load at the end of a 50Ohm, un-terminated, 5 inch microstrip trace on standard FR4 (1.5pF/inch), (25pF total with margin).
- The SDHC_CLK rise/fall time specification applies to the input clock transition required in order to meet the output delay specifications. SDHC_CLK output transition time is dependent on output load and GPIO pad drive strength. See the GPIO pad specifications for detail.
- Input timing assumes an input signal slew rate of 3ns (20%/80%).

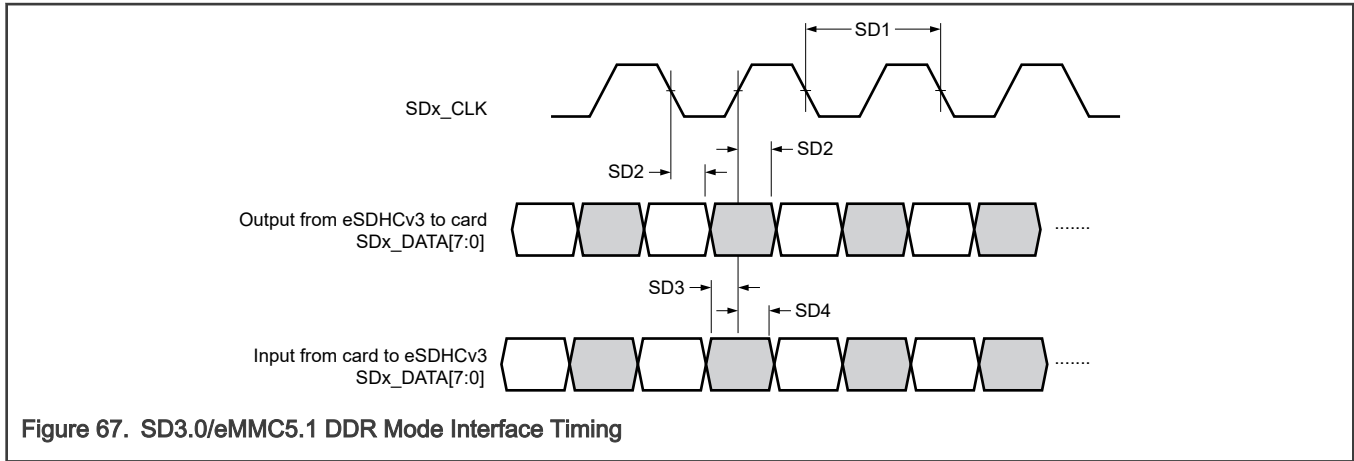

Figure 67. SD3.0/eMMC5.1 DDR Mode Interface Timing

16.10.2 uSDHC SD3.0/SDIO3.0/eMMC5.1 SDR

The SRE[2:0]=101 is required drive setting to meet the timing.

All uSDHC parameters are measured at mid-supply (VDD_IO_SDHC/2).

Table 63. uSDHC SD3.0/SDIO3.0/eMMC5.1 SDR

Symbol	Description	Min	Typ	Max	Unit	Condition	Spec Number
fpp	Clock frequency (low speed) ^{1, 2}	—	—	400	kHz	—	SD1
fpp	Clock frequency (SD/SDIO full speed/high speed) ^{2, 3}	—	—	25/50	MHz	—	SD1
fpp	Clock frequency (eMMC full speed/high speed) ^{2, 4}	—	—	20/52	MHz	—	SD1
fOD	Clock frequency (identification mode) ²	100	—	400	kHz	—	SD1
tWL	Clock low time	8.8	—	—	ns	—	SD2
tWH	Clock high time	8.8	—	—	ns	—	SD3
tTLH	Clock rise time ^{2, 5}	—	—	0.8	ns	—	SD4
tTHL	Clock fall time ^{2, 5}	—	—	0.8	ns	—	SD5
tOD	SDHC output delay (output valid) ²	-5.6	—	2.6	ns	SDHC_CLK to SDHC_CMD / SDHC_DAT	SD6
tISU	SDHC Input setup time ⁶	4.8	—	—	ns	SDHC_CMD / SDHC_DAT to SDHC_CLK	SD7
tIH	SDHC Input hold time ⁶	1.5	—	—	ns	SDHC_CLK to SDHC_CMD / SDHC_DAT	SD8

1. In low speed mode, card clock must be lower than 400 kHz, voltage ranges from 2.7V to 3.6V.
2. Output timing valid for maximum external load CL = 25pF, which is assumed to be a 10pF load at the end of a 50Ohm, un-terminated, 5 inch microstrip trace on standard FR4 (1.5pF/inch), (25pF total with margin).

3. In normal (full) speed mode for SD/SDIO card, clock frequency can be any value between 0–25 MHz. In high-speed mode, clock frequency can be any value between 0–50 MHz.
4. In normal (full) speed mode for MMC card, clock frequency can be any value between 0–20 MHz. In high-speed mode, clock frequency can be any value between 0–52 MHz.
5. The SDHC_CLK rise/fall time specification applies to the input clock transition required in order to meet the output delay specifications. SDHC_CLK output transition time is dependent on output load and GPIO pad drive strength. See the GPIO pad specifications for detail.
6. Input timing assumes an input signal slew rate of 3ns (20%/80%).

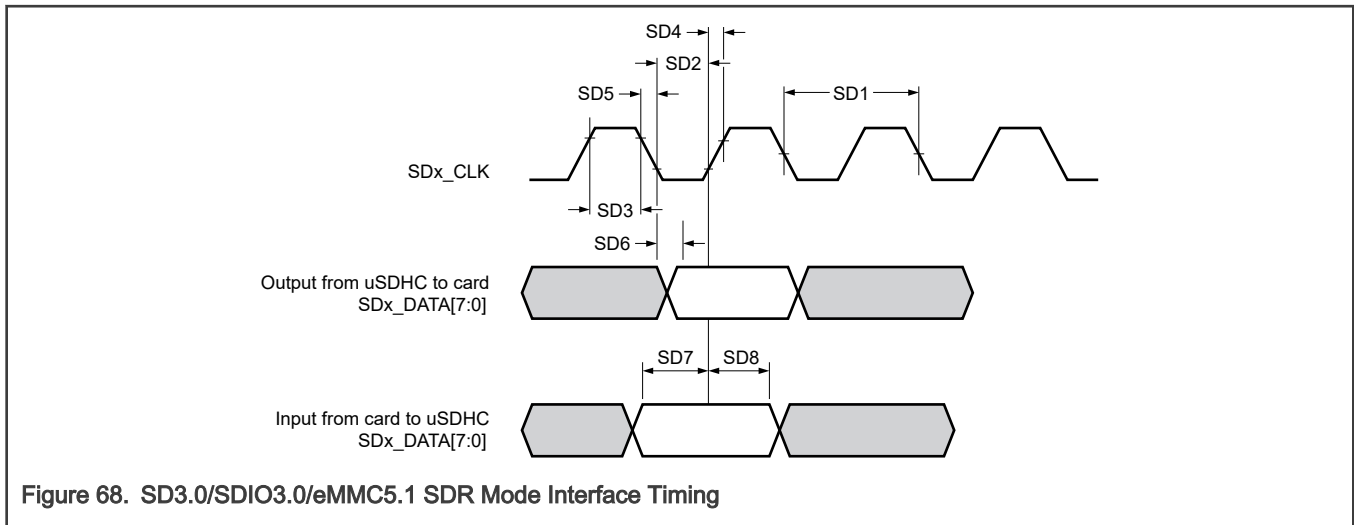

Figure 68. SD3.0/SDIO3.0/eMMC5.1 SDR Mode Interface Timing

16.10.3 uSDHC SDR-100MHz

The SRE[2:0]=101 is required drive setting to meet the timing.

All uSDHC parameters are measured at mid-supply (VDD_IO_SDHC/2).

Table 64. uSDHC SDR-100MHz

Symbol	Description	Min	Typ	Max	Unit	Condition	Spec Number
tCLK	Clock frequency ¹	—	—	100	MHz	—	SD1
tCL	Clock low time	4.5	—	—	ns	—	SD2
tCH	Clock high time	4.5	—	—	ns	—	SD3
tTLH	Clock rise time ^{1,2}	—	—	0.8	ns	—	—
tTHL	Clock fall time ^{1,2}	—	—	0.8	ns	—	—
tOD	uSDHC output delay ¹	-3.5	—	1.3	ns	SDHC_CLK to SDHC_CMD / SDHC_DAT	SD4
tISU	uSDHC input setup time ³	1.3	—	—	ns	SDHC_CMD / SDHC_DAT to SDHC_CLK	SD6
tIH	uSDHC input hold time ³	1.5	—	—	ns	SDHC_CLK to SDHC_CMD / SDHC_DAT	SD7

1. Output timing valid for maximum external load CL = 15pF, which is assumed to be a 10pF load at the end of a 50Ohm, un-terminated, 2 inch microstrip trace on standard FR4 (1.5pF/inch). For best signal integrity, the series resistance of the transmission line should be matched closely to the R_{DSOn} of the I/O pad output driver.

- The SDHC_CLK rise/fall time specification applies to the input clock transition required in order to meet the output delay specifications. SDHC_CLK output transition time is dependent on output load and GPIO pad drive strength. See the GPIO pad specifications for detail.
- Input timing assumes an input signal slew rate of 1ns (20%/80%).

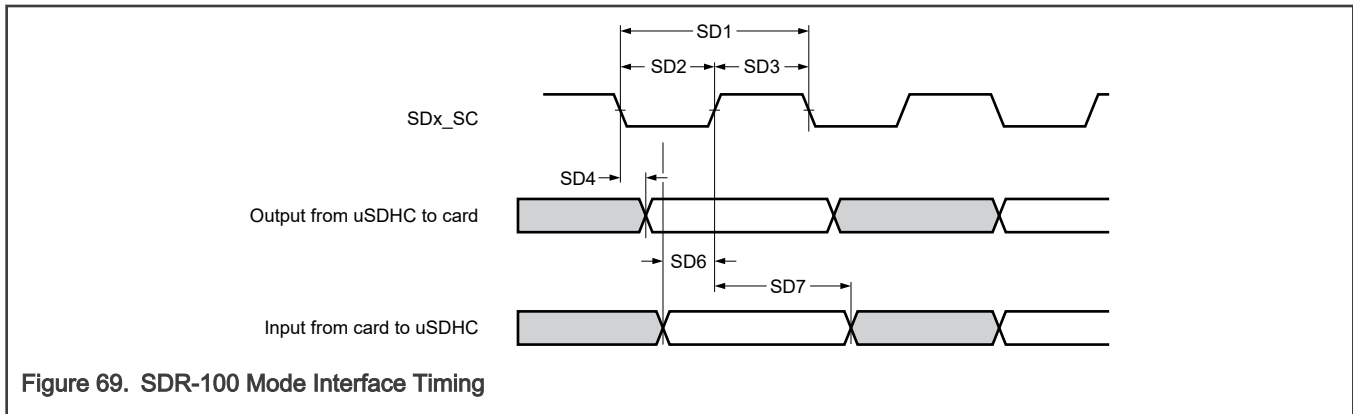

Figure 69. SDR-100 Mode Interface Timing

16.10.4 uSDHC SDR-HS200

The SRE[2:0]=000 is required drive setting to meet the timing.

All uSDHC parameters are measured at mid-supply (VDD_IO_SDHC/2).

Table 65. uSDHC SDR-HS200

Symbol	Description	Min	Typ	Max	Unit	Condition	Spec Number
tCLK	Clock frequency ¹	—	—	200	MHz	—	SD1
tCL	Clock low time	2.2	—	—	ns	—	SD2
tCH	Clock high time	2.2	—	—	ns	—	SD3
tTLH	Clock rise time ^{1,2}	—	—	0.8	ns	—	—
tTHL	Clock fall time ^{1,2}	—	—	0.8	ns	—	—
tOD	uSDHC output delay ¹	-1.2	—	0.6	ns	SDHC_CLK to SDHC_CMD / SDHC_DAT	SD4
tODW	Input data window ^{3,4}	2.6	—	—	ns	—	SD8

- Output timing valid for maximum external load CL = 15pF, which is assumed to be a 10pF load at the end of a 50Ohm, un-terminated, 2 inch microstrip trace on standard FR4 (1.5pF/inch). For best signal integrity, the series resistance of the transmission line should be matched closely to the RDSON of the I/O pad output driver.
- The SDHC_CLK rise/fall time specification applies to the input clock transition required in order to meet the output delay specifications. SDHC_CLK output transition time is dependent on output load and GPIO pad drive strength. See the GPIO pad specifications for detail.
- Input timing assumes an input signal slew rate of 1ns (20%/80%).
- Input timing also applicable for SDHC_CMD also.

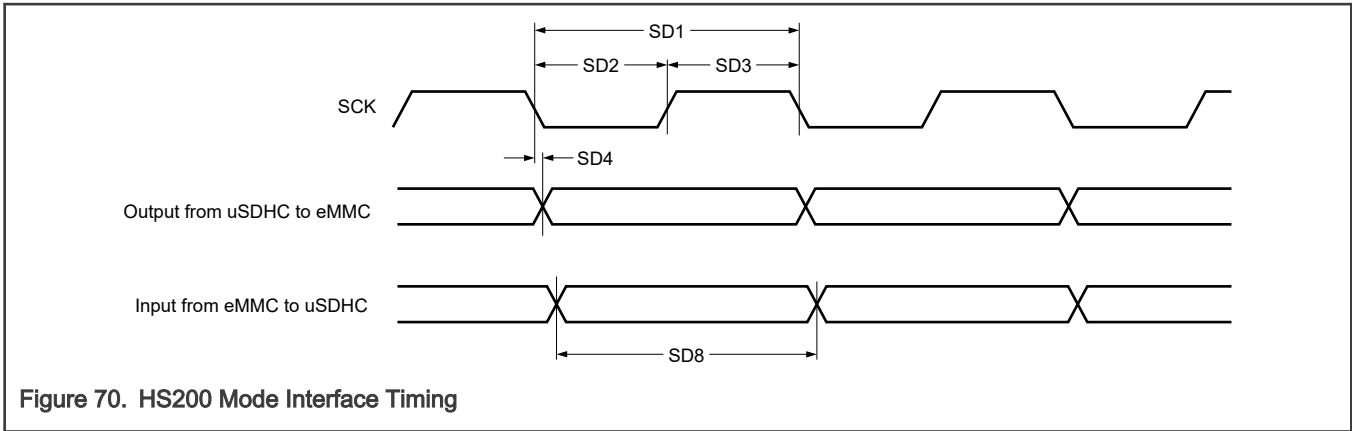

Figure 70. HS200 Mode Interface Timing

16.10.5 uSDHC DDR-HS400

In Split SRE configuration SRE[2:0]=000 for Data/CMD and SRE[2:0]=111 for CLK are the required drive settings to meet the timing.

Data transitions measured at 35%/65% supply for the write path. Data transitions measured at mid-supply for the read path. Clock transitions measured at mid-supply.

Table 66. uSDHC DDR-HS400

Symbol	Description	Min	Typ	Max	Unit	Condition	Spec Number
fPP	Clock frequency ¹	133	—	200	MHz	—	SD1
tCL	Clock low time	2.35	—	—	ns	—	SD2
tCH	Clock high time	2.35	—	—	ns	—	SD3
tTLH	Clock rise time ^{1,2}	—	—	0.8	ns	—	—
tTHL	Clock fall time ^{1,2}	—	—	0.8	ns	—	—
tOD1	Output skew from Edge of Data to SCK ^{1,3}	0.65	—	—	ns	—	SD4
tOD2	Output skew from Edge of SCK to Data ^{1,3}	0.65	—	—	ns	—	SD5
tRQ	Input skew ^{4,5}	—	—	0.45	ns	—	SD6
tRQH	Hold skew ^{4,5}	—	—	0.45	ns	—	SD7
tOD	uSDHC Output delay ¹	-1.2	—	0.9	ns	SDHC_CLK to SDHC_CMD	SD5

- Output timing valid for maximum external load CL = 15 pF, which is assumed to be a 10 pF load at the end of a 500ohm, un-terminated, 2-inch microstrip trace on standard FR4 (1.5pF/inch). For best signal integrity, the series resistance of the transmission line should be matched closely to the RDSON of the I/O pad output driver.
- The SDHC_CLK rise/fall time specification applies to the input clock transition required in order to meet the output delay specifications. SDHC_CLK output transition time is dependent on output load and GPIO pad drive strength. See the GPIO pad specifications for detail.
- Board skew margin between CLK and DATA/CMD is considered as +/-50 ps in calculations
- Input timing assumes an input signal slew rate of 1ns (20%/80%).
- Spec numbers SD6 and SD7 are also applicable for the CMD input timing for HS400 mode in enhanced strobe mode. For HS400 mode without enhanced strobe, CMD input timing is the same as for HS200 mode.

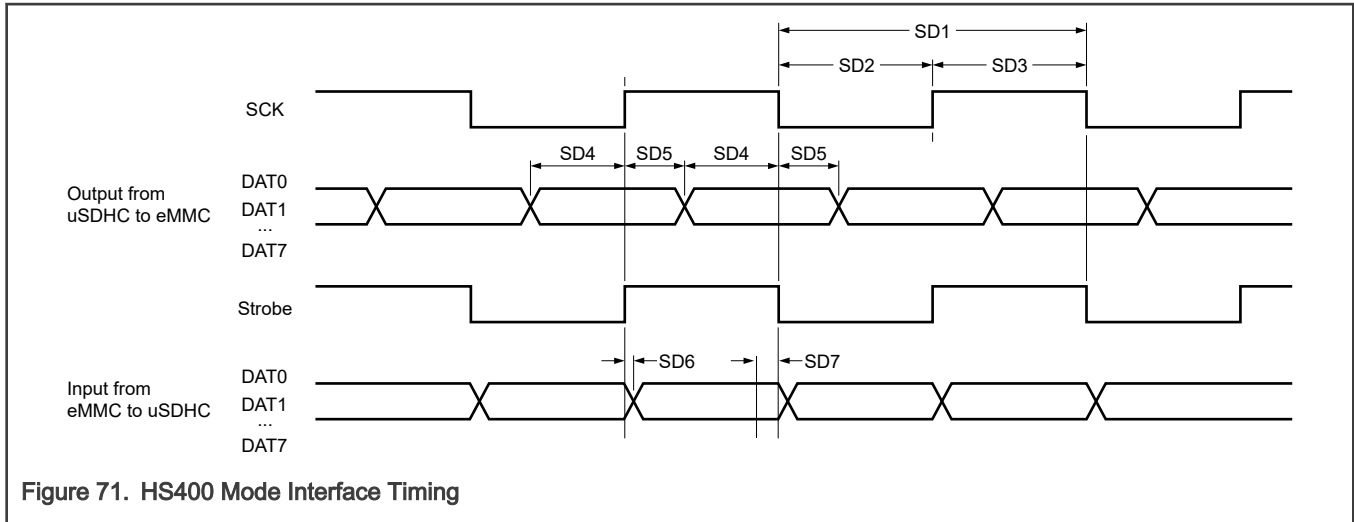

16.11 Debug modules

16.11.1 JTAG Boundary Scan

The following table gives the JTAG specifications in boundary scan mode.

The SRE[2:0]=100 or SRE[2:0]=101 is required drive setting to meet the timing.

Table 67. JTAG Boundary Scan

Symbol	Description	Min	Typ	Max	Unit	Condition	Spec Number
tJCYC	TCK cycle time ^{1, 2, 3}	100	—	—	ns	—	1
tJDC	TCK clock pulse width ^{2, 3}	45	—	55	%	—	2
tTCKRISE	TCK rise/fall time ^{2, 4}	—	—	3	ns	—	3
tTMSS, tTDIS	TMS, TDI data setup time ^{2, 5}	5	—	—	ns	—	4
tTMSH, tTDIH	TMS, TDI data hold time ^{2, 5}	5	—	—	ns	—	5
tTDOV	TCK low to TDO data valid ^{2, 6, 7}	—	—	17.5	ns	—	6
tTDOI	TCK low to TDO data invalid ^{2, 6}	0	—	—	ns	—	7
tTDOHZ	TCK low to TDO high impedance ^{2, 6}	—	—	17.5	ns	—	8
tJCMPPW	JCOMP assertion time ²	100	—	—	ns	—	9
tJCMPS	JCOMP setup time to TCK high ²	40	—	—	ns	—	10

Table continues on the next page...

Table 67. JTAG Boundary Scan (continued)

Symbol	Description	Min	Typ	Max	Unit	Condition	Spec Number
tBSDV	TCK falling edge to output valid ^{2, 6, 8}	—	—	600	ns	—	11
tBSDVZ	TCK falling edge to output valid out of high impedance ^{2, 6}	—	—	600	ns	—	12
tBSDVHZ	TCK falling edge to output high impedance ^{2, 6}	—	—	600	ns	—	13
tBSDST	Boundary scan input valid to TCK rising edge ²	15	—	—	ns	—	14
tBSDHT	TCK rising edge to boundary scan input invalid ²	15	—	—	ns	—	15

1. JTAG port interface speed only. Does not apply to boundary scan timing.
2. These specifications apply to JTAG boundary scan mode only.
3. TCK pin must have external pull down.
4. The TCK rise/fall time specification applies to the input clock transition required in order to meet the TDO output specifications that are relative to TCK.
5. Input timing assumes an input signal slew rate of 3ns (20%/80%).
6. Output timing valid for maximum external load CL = 25pF, which is assumed to be a 10pF load at the end of a 50Ohm, un-terminated, 5 inch microstrip trace on standard FR4 (1.5pF/inch), (25pF total with margin). For best signal integrity, the series resistance of the transmission line should be matched closely to the selected RDSON of the I/O pad output driver.
7. Timing includes TCK pad delay, clock tree delay, logic delay and TDO output pad delay.
8. Applies to all pins, limited by pad slew rate. Refer to IO delay and transition specification and add 20 ns for JTAG delay.

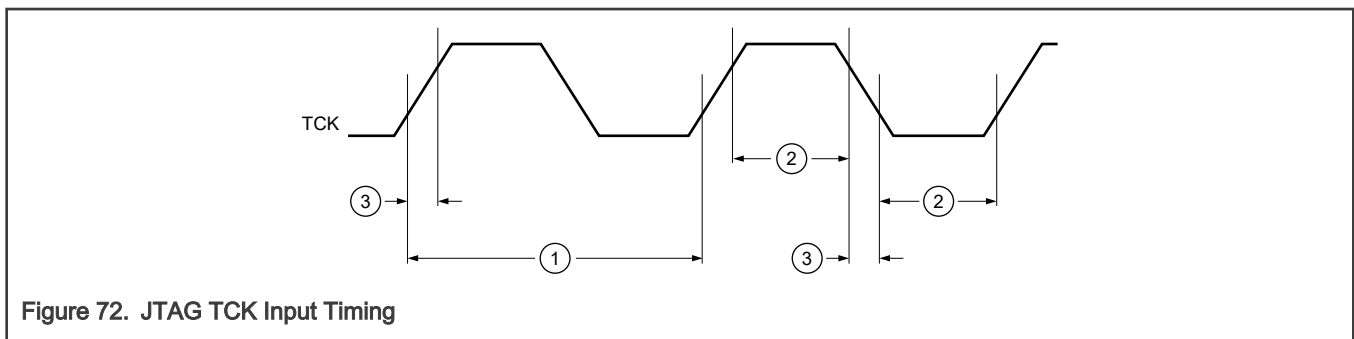

Figure 72. JTAG TCK Input Timing

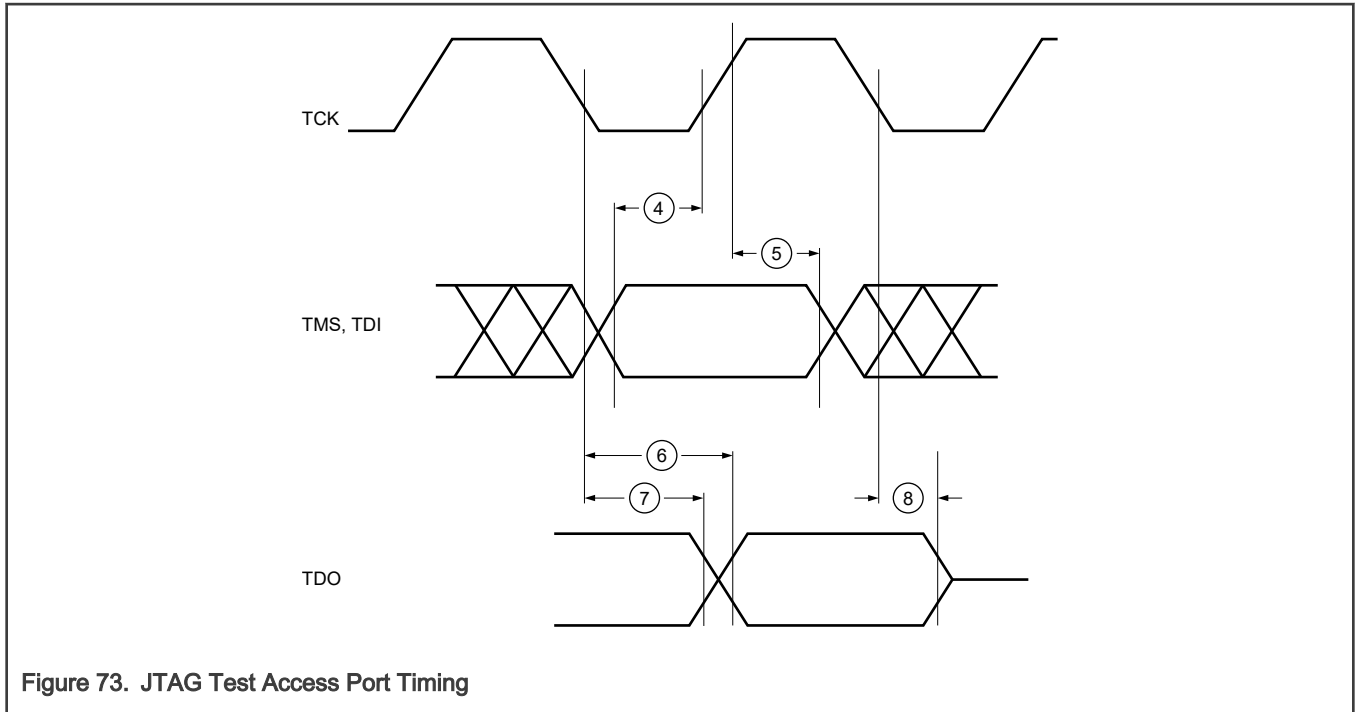

Figure 73. JTAG Test Access Port Timing

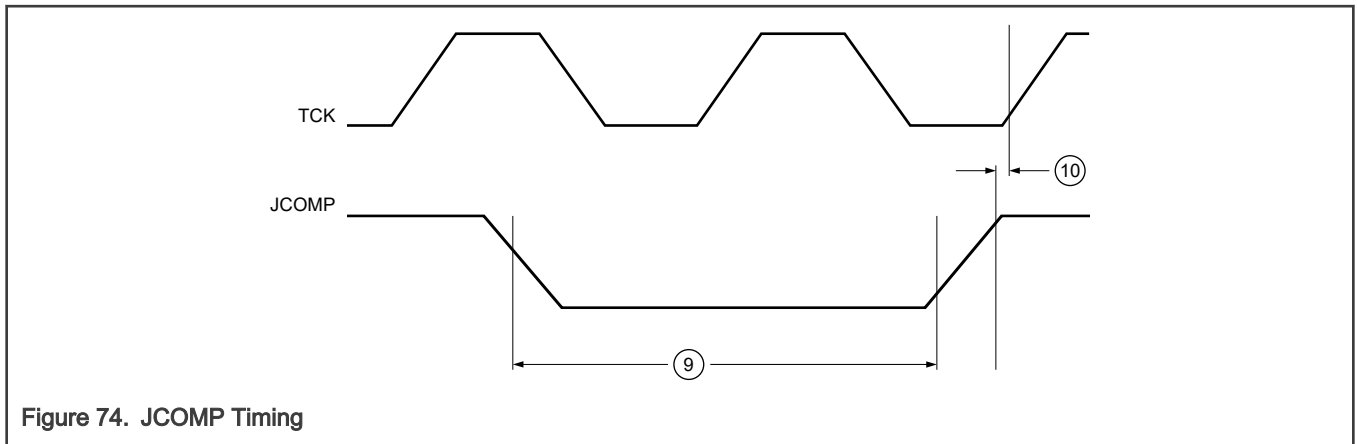

Figure 74. JCOMP Timing

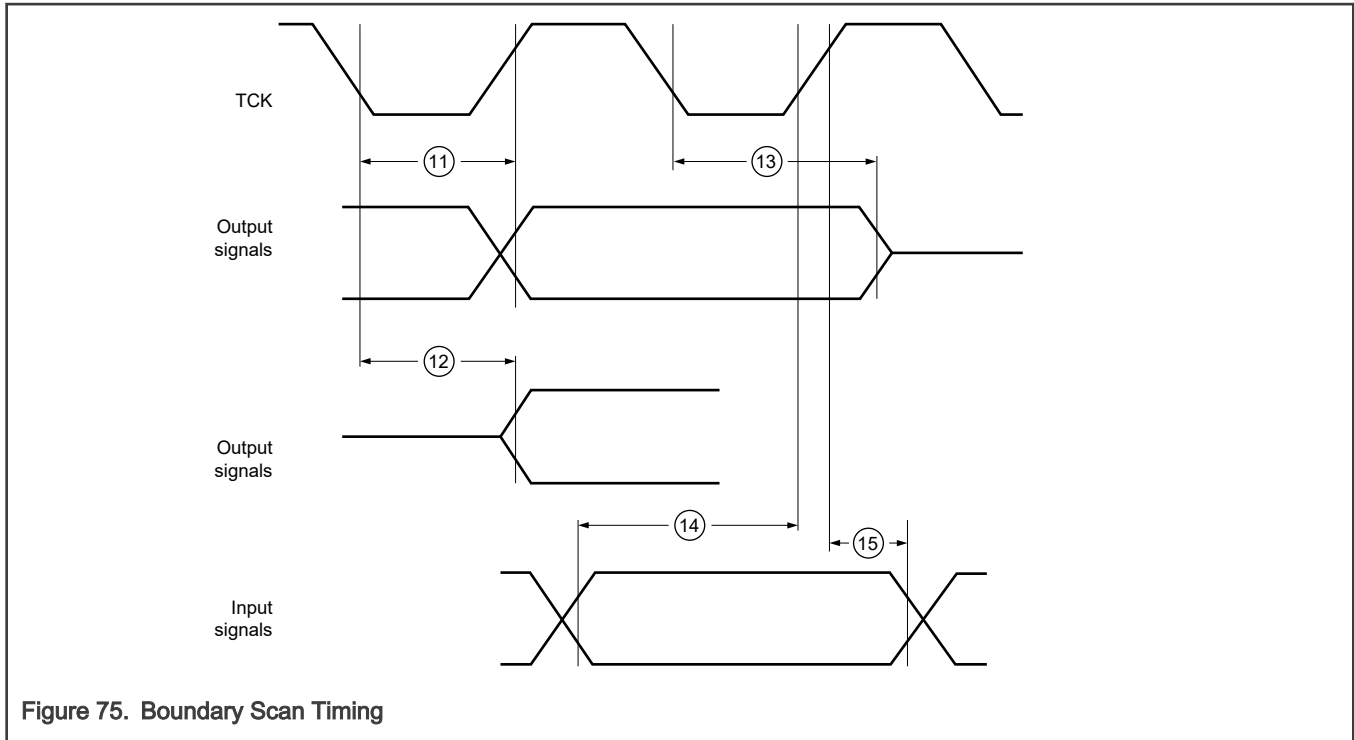

Figure 75. Boundary Scan Timing

16.11.2 JTAG Debug Interface Timing

The following table gives the JTAG specifications in debug interface mode.

Table 68. JTAG Debug Interface Timing

Symbol	Description	Min	Typ	Max	Unit	Condition	Spec Number
tTCYC	Absolute minimum TCK cycle time (TDO sampled on posedge of TCK) ^{1, 2}	50	—	—	ns	—	—
tTCYC	Absolute minimum TCK cycle time (TDO sampled on negedge of TCK) ^{1, 2}	25	—	—	ns	—	—
tJDC	TCK clock pulse width	45	—	55	%	—	—
tNTDIS	TDI data setup time ³	5	—	—	ns	—	11
tNTDIH	TDI data hold time ³	5	—	—	ns	—	12
tNTMSS	TMS data setup time	5	—	—	ns	—	13
tNTMSH	TMS data hold time	5	—	—	ns	—	14

Table continues on the next page...

Table 68. JTAG Debug Interface Timing (continued)

Symbol	Description	Min	Typ	Max	Unit	Condition	Spec Number
tNTDOD	TDO propagation delay from falling edge of TCK ^{4, 5}	—	—	17.5	ns	—	15
tNTDOH	TDO hold time with respect to falling edge of TCK ⁴	1	—	—	ns	—	16
tTDOHZ	TCK low to TDO high impedance ⁴	—	—	17.5	ns	—	—

1. Maximum frequency for TCK is limited to 6MHz during BOOTROM startup of the device, when the system clock is the trimmed 48MHz FIRC.
2. TCK pin must have external pull down.
3. Input timing assumes an input signal slew rate of 3ns (20%/80%).
4. Output timing valid for maximum external load CL = 25pF, which is assumed to be a 10pF load at the end of a 50Ohm, un-terminated, 5 inch microstrip trace on standard FR4 (1.5pF/inch), (25pF total with margin). For best signal integrity, the series resistance of the transmission line should be matched closely to the RDSON of the I/O pad output driver.
5. Timing includes TCK pad delay, clock tree delay, logic delay and TDO output pad delay.

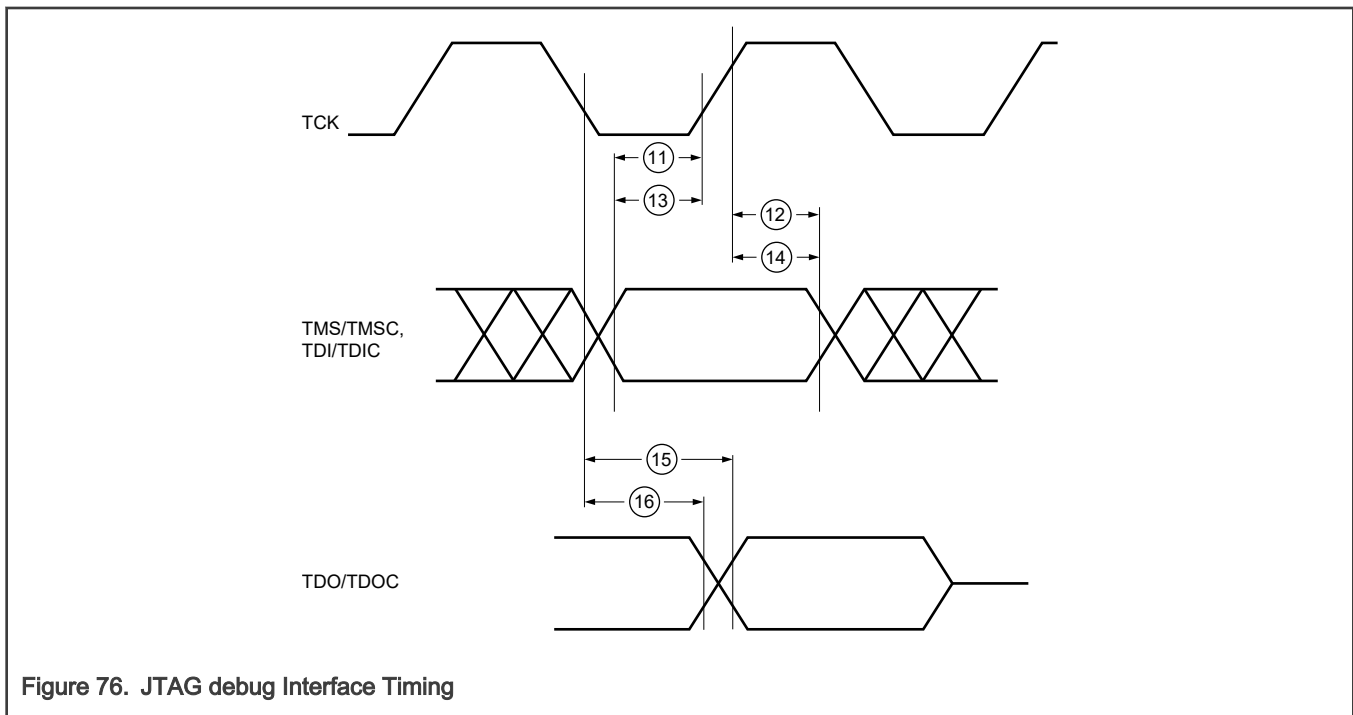

Figure 76. JTAG debug Interface Timing

16.11.3 SWD electrical specifications

The following table describes the SWD electrical characteristics. Measurements are with maximum output load of 30pF, input transition of 1ns and pad configured SRE[2:0] =100.

Table 69. SWD electrical specifications

Symbol	Description	Min	Typ	Max	Unit	Condition	Spec Number
S1	SWD_CLK frequency	—	—	33	MHz	—	S1
S2	SWD_CLK cycle period	1 / S1	—	—	ns	—	S2
S3	SWD_CLK pulse width	40	—	60	%	—	S3
S4	SWD_CLK rise and fall times	—	—	1	ns	—	S4
S9	SWD_DIO input data setup time to SWD_CLK rise	5	—	—	ns	—	S9
S10	SWD_DIO input data hold time after SWD_CLK rising edge	5	—	—	ns	—	S10
S11	SWD_CLK high to SWD_DIO output data valid	—	—	22	ns	—	S11
S12	SWD_CLK high to SWD_DIO output data hi-Z	—	—	22	ns	—	S12
S13	SWD_CLK high to SWD_DIO output data invalid	0	—	—	ns	—	S13

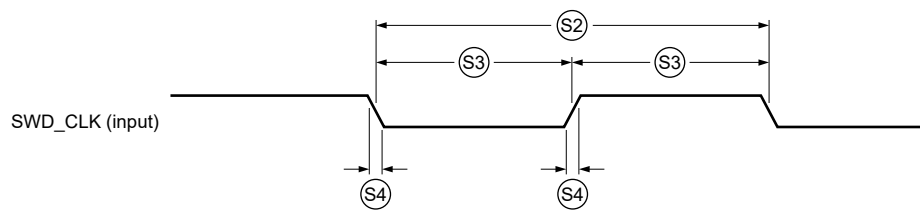

Figure 77. SWD Input Clock Timing

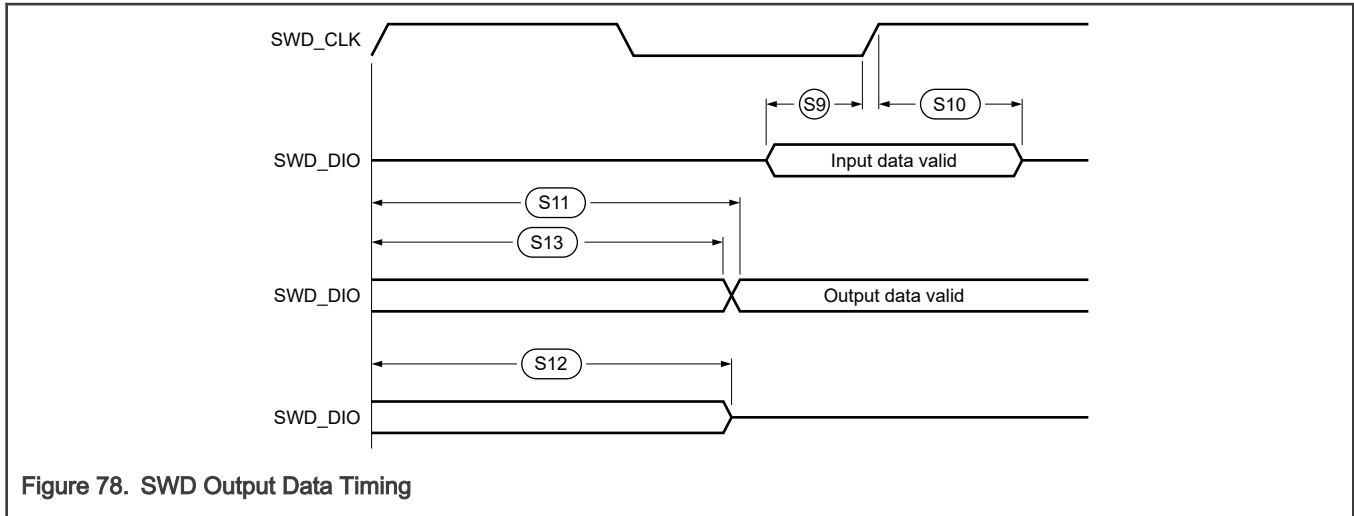

Figure 78. SWD Output Data Timing

17 Pinouts

For package pinouts and signal descriptions, see device Reference Manual.

18 Packaging

The S32G3 is offered in the following package types.

Package type	Document number
525-ball FCBGA	98ASA01463D

NOTE

To find a package drawing, go to <http://www.nxp.com> and perform a keyword search for the drawing's document number or see below figures.

H-FC-PBGA-525 I/O
19 X 19 X 1.97 PKG, 0.8 PITCH

SOT1655-5

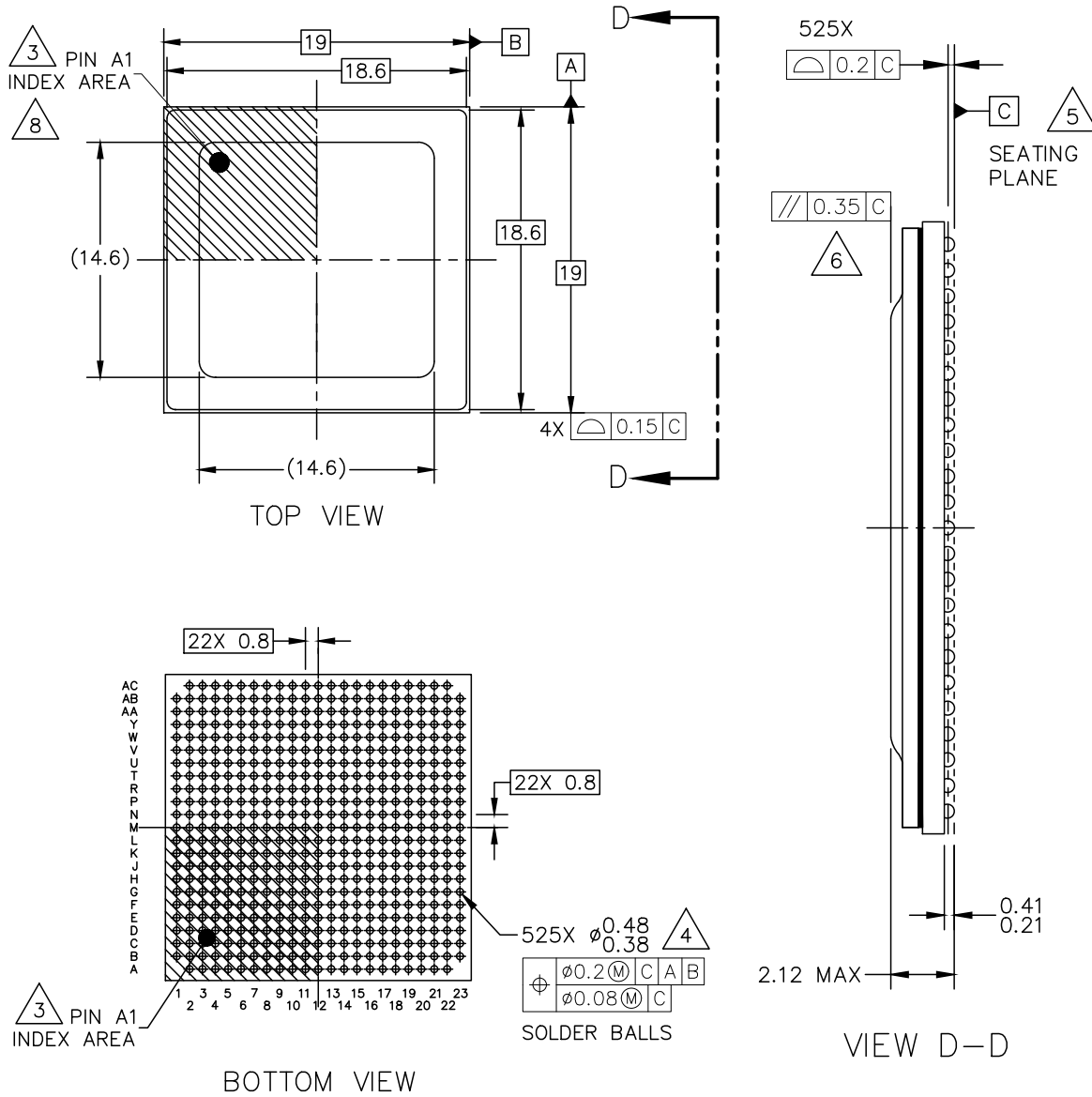

© NXP B.V. ALL RIGHTS RESERVED

DATE: 13 SEP 2022

MECHANICAL OUTLINE PRINT VERSION NOT TO SCALE	STANDARD: NON JEDEC	DRAWING NUMBER: 98ASA01463D	REVISION: D	PAGE: 1 OF 5
--	------------------------	--------------------------------	----------------	-----------------

Figure 79. Package outline

H-FC-PBGA-525 I/O
 19 X 19 X 1.97 PKG, 0.8 PITCH

SOT1655-5

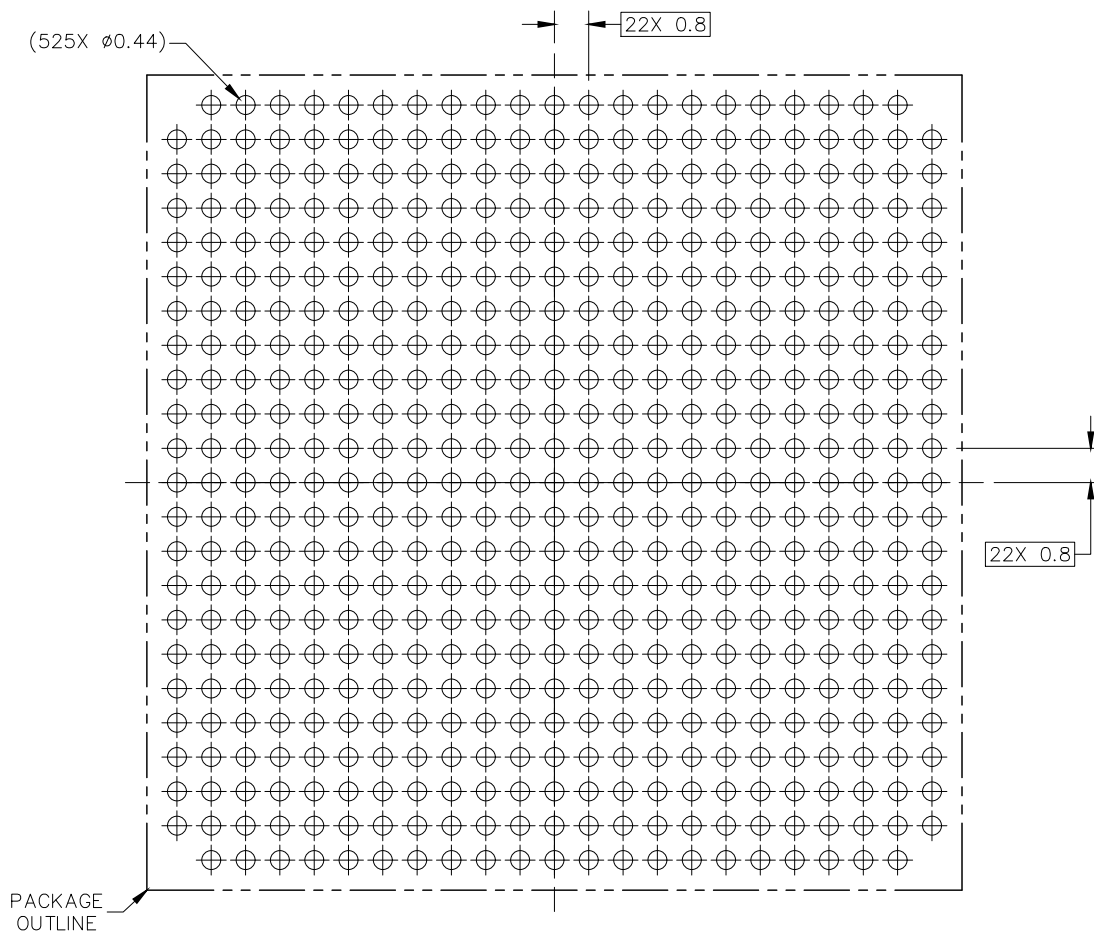

PCB DESIGN GUIDELINES – SOLDER MASK OPENING PATTERN

THIS SHEET SERVES ONLY AS A GUIDELINE TO HELP DEVELOP A USER SPECIFIC SOLUTION. DEVELOPMENT EFFORT WILL STILL BE REQUIRED BY END USERS TO OPTIMIZE PCB MOUNTING PROCESSES AND BOARD DESIGN IN ORDER TO MEET INDIVIDUAL/SPECIFIC REQUIREMENTS.



© NXP B.V. ALL RIGHTS RESERVED

DATE: 13 SEP 2022

MECHANICAL OUTLINE PRINT VERSION NOT TO SCALE	STANDARD: NON JEDEC	DRAWING NUMBER: 98ASA01463D	REVISION: D	PAGE: 2
--	------------------------	--------------------------------	----------------	------------

Figure 80. Soldering footprint part 1 of 3

H-FC-PBGA-525 I/O
 19 X 19 X 1.97 PKG, 0.8 PITCH

SOT1655-5

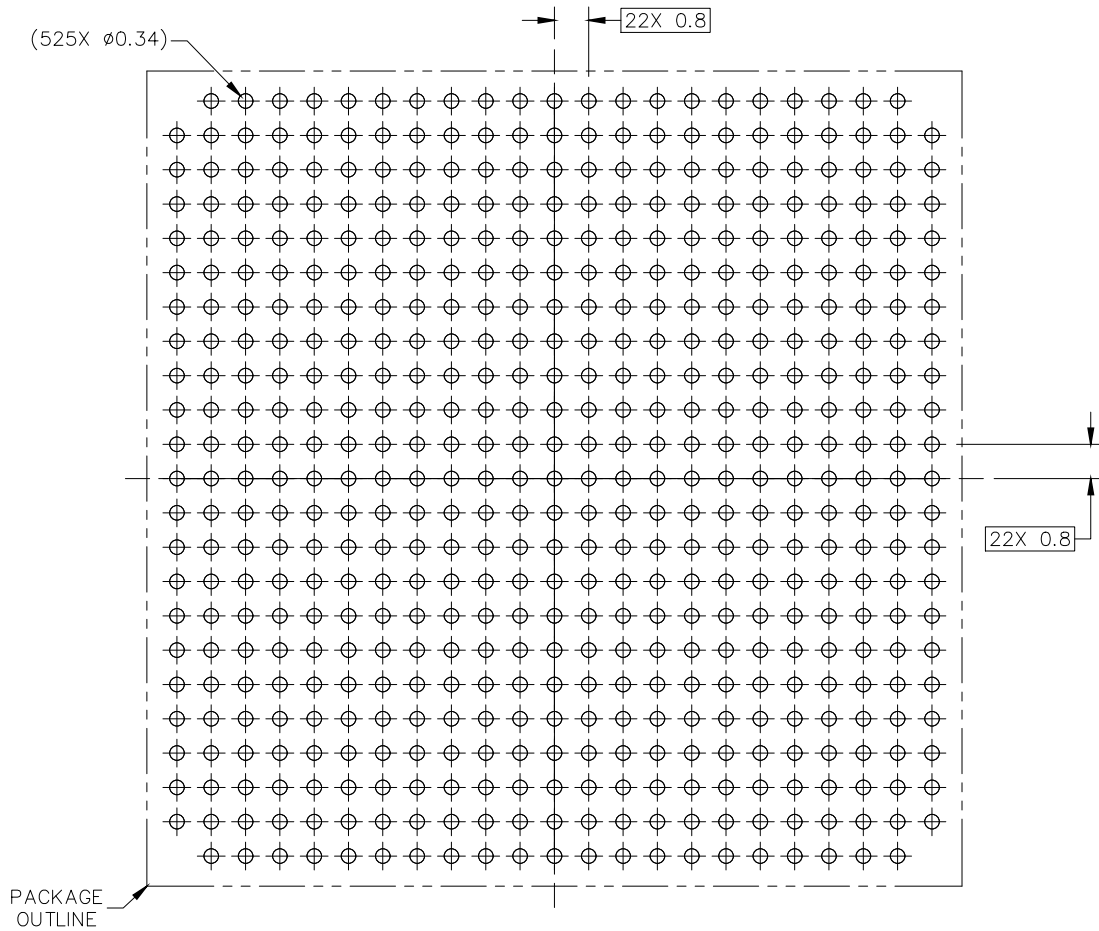

PCB DESIGN GUIDELINES – I/O PADS AND SOLDERABLE AREA

THIS SHEET SERVES ONLY AS A GUIDELINE TO HELP DEVELOP A USER SPECIFIC SOLUTION. DEVELOPMENT EFFORT WILL STILL BE REQUIRED BY END USERS TO OPTIMIZE PCB MOUNTING PROCESSES AND BOARD DESIGN IN ORDER TO MEET INDIVIDUAL/SPECIFIC REQUIREMENTS.



© NXP B.V. ALL RIGHTS RESERVED

DATE: 13 SEP 2022

MECHANICAL OUTLINE PRINT VERSION NOT TO SCALE	STANDARD: NON JEDEC	DRAWING NUMBER: 98ASA01463D	REVISION: D	PAGE: 3
--	------------------------	--------------------------------	----------------	------------

Figure 81. Soldering footprint part 2 of 3

H-FC-PBGA-525 I/O
 19 X 19 X 1.97 PKG, 0.8 PITCH

SOT1655-5

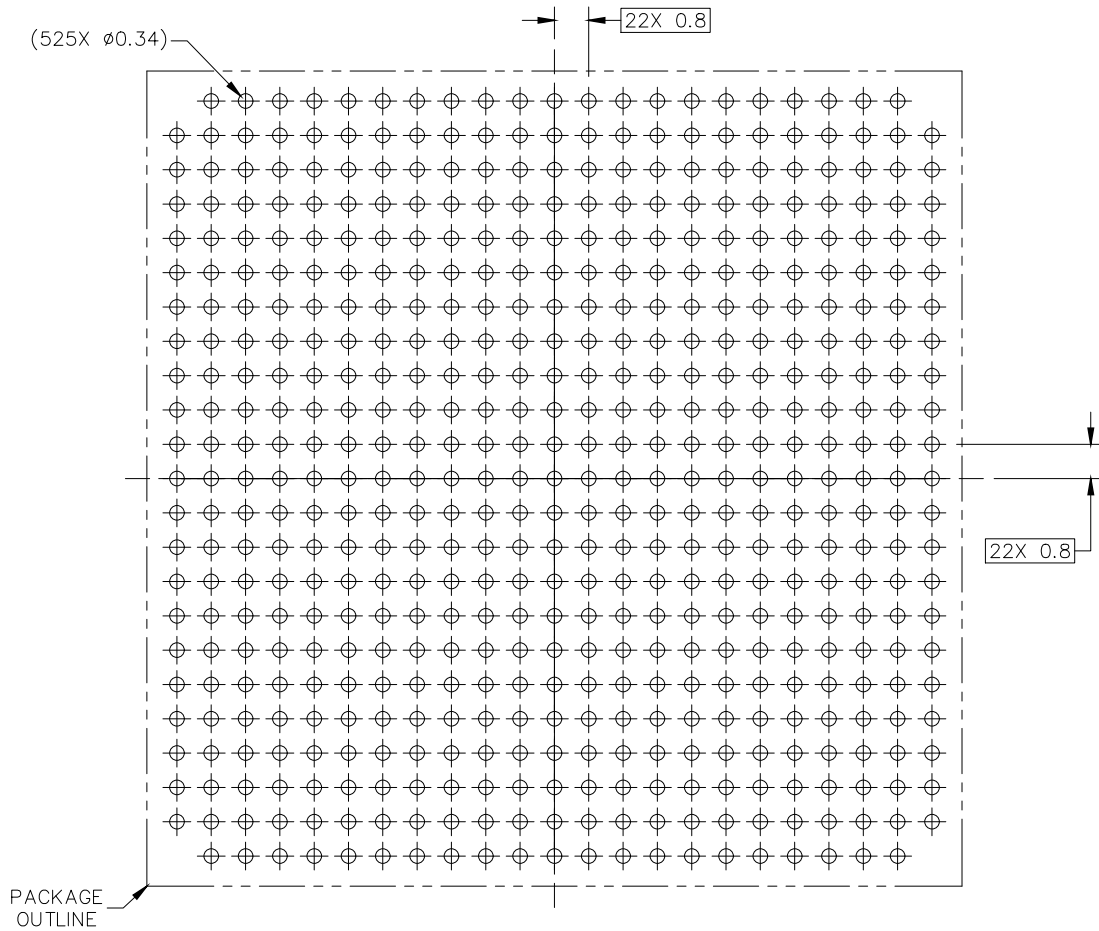

RECOMMENDED STENCIL THICKNESS 0.125MM

PCB DESIGN GUIDELINES – SOLDER PASTE STENCIL

THIS SHEET SERVES ONLY AS A GUIDELINE TO HELP DEVELOP A USER SPECIFIC SOLUTION. DEVELOPMENT EFFORT WILL STILL BE REQUIRED BY END USERS TO OPTIMIZE PCB MOUNTING PROCESSES AND BOARD DESIGN IN ORDER TO MEET INDIVIDUAL/SPECIFIC REQUIREMENTS.



© NXP B.V. ALL RIGHTS RESERVED

DATE: 13 SEP 2022

MECHANICAL OUTLINE PRINT VERSION NOT TO SCALE	STANDARD: NON JEDEC	DRAWING NUMBER: 98ASA01463D	REVISION: D	PAGE: 4
--	------------------------	--------------------------------	----------------	------------

Figure 82. Soldering footprint part 3 of 3

H-FC-PBGA-525 I/O
 19 X 19 X 1.97 PKG, 0.8 PITCH

SOT1655-5

NOTES:

1. ALL DIMENSIONS IN MILLIMETERS.
2. DIMENSIONING AND TOLERANCING PER ASME Y14.5M-1994.
3. PIN A1 FEATURE SHAPE, SIZE AND LOCATION MAY VARY.
4. MAXIMUM SOLDER BALL DIAMETER MEASURED PARALLEL TO DATUM C.
5. DATUM C, THE SEATING PLANE, IS DETERMINED BY THE SPHERICAL CROWNS OF THE SOLDER BALLS.
6. PARALLELISM MEASUREMENT SHALL EXCLUDE ANY EFFECT OF MARK ON TOP SURFACE OF PACKAGE.
7. LID OVERHANG ON SUBSTRATE NOT ALLOWED.
8. VENT AREA BETWEEN LID AND SUBSTRATE, SIZE MAY VARY.



© NXP B.V. ALL RIGHTS RESERVED

DATE: 13 SEP 2022

MECHANICAL OUTLINE PRINT VERSION NOT TO SCALE	STANDARD: NON JEDEC	DRAWING NUMBER: 98ASA01463D	REVISION: D	PAGE: 5
--	------------------------	--------------------------------	----------------	------------

Figure 83. Package outline notes

19 Revision history

The following table lists the changes in this document.

Rev 2, Feb 2023
<ul style="list-style-type: none"> • In section "Absolute Max Ratings", updated figure title to match with specifications "Input overshoot/undershoot voltage for each GPIO pad type". • In section "Operating conditions", added note to Tj and Ta as "The junction temperature (Tj) range specification...". • In section "Operating conditions", added figure "ADC supply sequencing". • In section "GPIO pads": <ul style="list-style-type: none"> — for TR_TF_33 with SRE[2:0] = 100 changed min from 1.75V to 1.90V. — for TR_TF_33 with SRE[2:0] = 101 changed min from 0.05V to 1.00V and max changed from 8.25V to 8.50V. — for TR_TF_33 with SRE[2:0] = 110 changed min from 0.01V to 0.50V and max changed from 7.0V to 7.30V. — for TR_TF_33 with SRE[2:0] = 111 changed min from 0.005V to 0.04V and max changed from 5.5V to 6.0V. • In section "SAR ADC", paragraph at top of table is updated to mention from "...capacitance at the input pin should..." to "...capacitance at the input pin and reference pin should...". • In section "Temperature Monitoring Unit (TMU)", updated TRANGE min as -45 and max as 130 and added a footnote "Accuracy outside of operating range (-40 to 125) is not guaranteed." • In section "FXOSC", added paragraph as "In ALC disable mode the minimum...". • In section "PLL", added footnote to fPLL_DDR_PHI0 as "DDR PLL allows center-spread SSCG at...". • In section "PLL", added footnotes to Jitter specifications to mention jitter dependency. • In section "FlexRay - RxD", deleted uCCLogic_1 and uCCLogic_2 specifications. • In section "PCIe", updated paragraph "NXP internally does PCI-SIG TX...". • In section "QuadSPI Octal 1.8V DDR 166MHz": <ul style="list-style-type: none"> — Updated voltage measurement levels "Data transitions measured at 30%/70% supply...". — Updated tIH_DQS min from 2.145 ns to 2.105 ns — Updated tISU_DQS min from -0.496 ns to -0.616 ns • In section "QuadSPI Octal 1.8V DDR 200MHz": <ul style="list-style-type: none"> — Updated voltage measurement levels "Data transitions measured at 30%/70% supply...". — Updated SRE "In Single SRE configuration...". — Updated tOD_DATA for single and split SRE configurations. — Updated tIH_DQS min from 1.684 ns to 1.644 ns. — Updated tISU_DQS min from -0.466 ns to -0.586 ns. • In section "QuadSPI configurations" SMPR[DLLFSMPF] is updated to 4 for 166 MHz. • In section "uSDHC DDR-HS400": <ul style="list-style-type: none"> — Updated SRE "In Split SRE configuration SRE[2:0]=000...". — Updated voltage measurement levels "Data transitions measured at 35%/65% supply...".

Table continues on the next page...

Rev 2, Feb 2023

- Updated tCL and tCH min to 2.35 ns.
- Updated descriptions of tOD1 and tOD2 and updated its value to 0.65 ns.
- Added tOD (uSDHC Output delay).
- Added package drawing.
- Datasheet classification updated to "Technical Data".

Rev 2 Draft C, Sep 2022

- In "Absolute Max Ratings"
 - Added note "All specifications associated with VIN are measured at the SoC pin."
 - Added spec Max LVDS RX or TX pin injection (IINJ_LVDS)
 - VIN specification:
 - updated footnote "Absolute maximum DC VIN levels for a powered..."
 - Added V_OS_US_10 for 1.8V and updated condition of overshoot and undershoot specifications.
 - Added footnote "DC case limit. Overshoot/Undershoot beyond this range..."
 - For Overshoot/Undershoot specs updated footnote, "For AC Signals in a 3.3V supply domain, if..."
- In section "Operating Conditions" Added footnoted to VIN_18 and VIN_33 "DC case limit. Overshoot/Undershoot beyond this range..."
- In section "Operating Conditions" IINJ_D is split into powered and unpowered and related footnotes added."
- In section "Clock frequency ranges" added fSDHC_CLK for DDR HS400.
- In section "Device Power and Operating Current Specifications", for PVDD_STBY in condition corrected a typographic figure from VDD=0.8V, to VDD_STBY = 0.8V.
- Added section "Power-down".
- In section "Aurora PLL" added footnote to fPLL_CLKIN as "40MHz is the only internal input reference..".
- In section "Reset Duration" added a paragraph as "The durations specified "Reset Duration" table and the corresponding figures...." and added below three figures:
 - Reset_b pad detailed behavior during core supply brownout
 - Reset_b pad detailed behavior during pad HV supply brownout
 - Reset_b pad detailed behavior during power down
- Below figure "RESET_B pad detailed behavior", added information as "he RESET_B pad behavior described in the diagram and the related VRSE_RESET_B parameter spec also apply to the case of core VDD droop after power-up."
- In section "SIRC", PTA description changed from "SIRC Post Trim Accuracy" to "SIRC trimming resolution" and "SIRC Frequency Variation" condition updated to "Frequency variation across voltage and temperature range".
- In section "I2C" PER_CLK changed to MODULE_CLK.
- Added section "CAN".
- In QuadSPI sections, removed DQS and added condition as "fSCK duty cycle distortion is in the range of 45%-55%."

Table continues on the next page...

Rev 2 Draft C, Sep 2022

- In uSDHC:
 - Changed title from "uSDHC DDR-52MHz" to "uSDHC SD3.0/eMMC5.1 DDR" and from "uSDHC SDR-52MHz" to "uSDHC SD3.0/SDIO3.0/eMMC5.1 SDR" and other figure name updates.
 - In uSDHC added phrase as "All uSDHC parameters are measured at mid-supply (VDD_IO_SDHC/2)."
 - In "SDR-100 Mode Interface Timing" figure deleted SD5 and SD8.
 - In section "uSDHC SDR-HS200" added footnote to tODW as "Input timing also applicable for SDHC_CMD also."
 - In "uSDHC DDR-HS400" added footnote to tRQ and tRQH as "Spec numbers SD6 and SD7 are also applicable for the CMD input timing for HS400 mode..."
 - Deleted some redundant figures.

Rev 2 Draft B, May 2022

- In "GMAC and PFE RGMII" section added paragraph "You must set SRE[2:0]=101 for PFE_MAC0_TX_CLK in RGMII mode of PFE GMAC0 at 3.3V."

Rev 2 Draft A, Apr 2022

- In "Block diagram" mentioned that the diagram represents the features of S32G399A, the superset chip in the S32G3 family.
- In section "Absolute maximum ratings":
 - Changed from ADC reference supply to ADC supply for "VAD_INPUT", min value changed from "VREFL_ADC - 0.6" to "VSS_ADC - 0.6" and max value changed from "VREFH_ADC + 0.5" to "VDD_ADC + 0.5".
 - Added more information to below footnotes attached to VIN:
 - Absolute maximum DC VIN levels for a powered device....
 - Absolute minimum DC VIN level for a powered device is....
 - Footnote attached to "IINJ_A" changed to "Allowed for a cumulative duration of 50 hours operation over the lifetime of the device at maximum T_j, with VDD_ADC ≤ 1.92V, VSS_ADC = 0V".
 - Added symbol names and footnote to overshoot specifications as "For AC signals, if VDD_IO ≤ 3.3V, max VIN overshoot is limited to...."
- In section "Operating Conditions":
 - Changed from ADC reference supply to ADC supply for "VAD_INPUT", min value updated from "VREFL_ADC - 0.35" to "VSS_ADC - 0.35" and max value updated from "VREFH_ADC + 0.25" to "VDD_ADC + 0.25".
 - Footnote attached to frequency specs updated to correct the modulation depth used in formula. Changed "...plus the modulation depth (max 1.5%) ..." to "...plus half the modulation depth...".
 - For "VDD_EFUSE" specs, updated related footnote to add "See device hardware design guidelines document for more details."
 - Updated below footnotes attached to VIN_18 and VIN_33:

Table continues on the next page...

Rev 2 Draft A, Apr 2022

- From: "Additional +0.3V are supported for DC signal." to "For AC signals, allowed max $V_{IN} \leq V_{DD_IO^*}$ for lifetime operation. If AC....".
- From: "Absolute minimum level for V_{IN} signal is -0.3V." to "The min DC V_{IN} level for a powered device is -0.3V. If AC.....".
- Footnote attached to "VRAMP_LV" is updated "On slow ramps, the RESET_B pin may be observed to be asserted..."
- Total power specifications updated for S32G398A (thermal use case) changed from 8.18 to 8.35 A, S32G379A (thermal use case) changed from 7.46 to 8.08 W, S32G378A (thermal use case) changed from 7.24 to 8.02 W.
- In "Total power specifications" for 1.8V supply rail added in condition "All 1.8V supplies at 1.8V".
- Max values updated for the specs in section "Static power specifications for I/O Domains"
- In section "Device Power and Operating Current Specifications" :
 - For symbol "PVDD_STBY", typ value changed from 48 to 58 μ W.
 - For symbol "PVDD_IO_STBY", typ value changed from 120 to 110 μ W.
- In section "Device Power and Operating Current Specifications" for symbol "PVDD_IO_PCIEn" (Powered down state), max value changed from 1.4 to 1.5 mW.
- In section "Device Power and Operating Current Specifications" for symbol "PVDD_IO_PCIEn" with condition "All circuits enabled, $V_{DD_IO_PCIEn}=1.8V$, Gen3 8Gbps, 2 lanes. Per IP instance", added footnote "This specification can be considered a worst case maximum..."
- In section "GPIO Pads", added symbols "VOL" and "VOH" and added a footnote attached to these symbols "For current at this voltage see IOL/IOH specs respectively".
- Removed a note "VOH/VOL values should be calculated based on the provided $R_{DS(on)}$, IOH/IOL values and IBIS models".
- In figure "1.8V/3.3V GPIO pad detailed behavior during power up", updated "weak pull-down" to "weak pull-down as per ILKG_3318 specification".
- Under the figure "1.8V/3.3V GPIO pad detailed behavior during power up", removed the paragraph "The weak pull-down is 100 Kohm and is separate from the usual selectable 12Kohm internal pull resistor...."
- In section "SAR ADC" , for symbol "VAD_INPUT" min value changed to "VSS_ADC" and max value changed to "VDD_ADC".
- In section "DFS", added symbol "PER_Jitter" with min value -30ps and max value 30ps with condition $f_{DFS_CLKIN}=2622$ Mhz, Odd MFN.
- In section "PLL" :
 - Added symbol "fPLL_DDR_PHI0" with description "DDR PLL PHI0 Frequency" and min, max value 758 Mhz and condition DDR_CLK (3032MT/s).
 - Footnote "PLL refers to the Core, Peripheral, Accelerator, and DDR reference PLLs on the device" and "Spread spectrum clock modulation is only available on the Core, Accelerator and DDR reference PLLs" moved to the top of the section.
 - The formula for calculating the max frequency is updated in the related footnote "The max frequency in case of center-spread SSCG enabled for a modulation....".
- In PCIe specifications external reference clock pins related specs are added.

Table continues on the next page...

Rev 2 Draft A, Apr 2022

- In section "GMAC and PFE SGMII", For symbol UI the description updated to "Unit interval (mean)".
- Added sentence "All transitions measured at mid-supply (VDD_IO_QSPI/2)" and removed "Clock measurements done with respect to VDD_IO_QSPI/2 level" in all QuadSPI modes.
- Removed symbol "tDVW" from the following sections:
 - "QuadSPI Quad 1.8V SDR 133MHz"
 - "QuadSPI Octal 1.8V DDR 100MHz"
 - "QuadSPI Octal 1.8V DDR 133MHz"
 - "QuadSPI Octal 1.8V DDR 166MHz"
 - "QuadSPI Octal 1.8V DDR 200MHz"
 - "QuadSPI Octal 1.8V SDR 100MHz"
 - "QuadSPI Octal 1.8V SDR 133MHz"
 - "QuadSPI Quad 3.3V SDR 104MHz"
- Added introduction sentence "The information in this section applies to Octal- and Hyperflash" in following sections :
 - QuadSPI Octal 1.8V DDR 100MHz
 - QuadSPI Octal 1.8V DDR 133MHz
 - QuadSPI Octal 1.8V DDR 166MHz
- In section "QuadSPI configurations", added introduction "The below table shows a subset of the QuadSPI module configurations for different speeds and data rate....".
- In section "QuadSPI configurations", updated SMPR[DLLFSMPF] setting for DDR-200MHz from 4 to 3.
- In section "DDR", updated the sentence to "LPDDR4 SDRAM compliant to JEDEC209-4B LPDDR4 JEDEC standard release."
- In section "DDR Common DC Output", for symbol "ROnPu" and "ROnPd", in description CLK changed to CKE outputs and footnote attached to them updated as "For the DDR0_RESET_B pin and CKE pin...."
- Added section "DDR3L DC Input Timing".
- Section name changed from "LPDDR4 DC Input" to "LPDDR4 DC Input Timing" and from "LPDDR4 Output" to "LPDDR4 Output Timing".
- Section "uSDHC DDR-HS400" updated thoroughly.
- Updated "Legal information"

Rev 1, Nov 2021

- Updated datasheet classification to "Advance information"
- Updated Introduction, Feature comparison.
- In section "Absolute Max Ratings" and "Operating conditions", VDD_LV_PLL is deleted as it is shorted with VDD inside the die and this supply no longer needs to be driven from outside.
- In section "Absolute Max Ratings", for Symbol "VAD_INPUT" Min changed from "-0.3" to "VREFL_ADC -0.6".

Table continues on the next page...

Rev 1, Nov 2021

- In section "Absolute Max Ratings", for Symbol "VAD_INPUT" Max changed from "VREFH_ADC" to "VREFH_ADC + 0.5".
- In section "Absolute Max Ratings", for Symbol "VAD_INPUT" footnote added "Allowed for a cumulative duration of 50 ...".
- In section "Absolute Max Ratings" two footnotes attached to VIN are updated:
 - Absolute maximum VIN levels ...
 - Absolute minimum VIN level for ...
- In section "Absolute Max Ratings", for Symbol "IINJ_A" Min changed from "-2" to "-1".
- In section "Absolute Max Ratings", for Symbol "IINJ_A" Max changed from "2" to "1".
- In section "Absolute Max Ratings" in a footnote attached to IINJ_A "Non-disturb of ADC channels during current"
- In section "Operating Conditions", added note " Δ VDD* specifications are applicable to the supplies mentioned ...".
- In section "Operating Conditions", for Symbol "fSYS_A53" Max changed from "1100" to "1311".
- In section "Operating Conditions", SVS feature is removed.
- In section "operating conditions" removed " Δ VDD_IO_DDR" differential as this has a lone supply in its condition.
- In section "Operating Conditions", Symbol "VRAMP_HV" is seperated for 1.8V and 3.3V IOs and 3.3V IOs limit is updated to 50V/ms.
- In section "Operating Conditions", for Symbol "VAD_INPUT" Min changed from "VREFL_ADC" to "VREFL_ADC - 0.35".
- In section "Operating Conditions", for Symbol "VAD_INPUT" Max changed from "VREFH_ADC" to "VREFH_ADC + 0.25".
- In section "Operating Conditions", for Symbol "IINJ_A" Min changed from "-1 mA" to "-20 uA".
- In section "Operating Conditions", for Symbol "IINJ_A" Max changed from "1 mA" to "20 uA".
- In section "Operating Conditions", for Symbol "IINJ_A" footnote updated "The SAR ADC electrical specifications ar...".
- In section "Operating conditions" for symbol " Δ VDD_HV_18_ANA" added footnotes to clarify VDD_EFUSE supply conditions and added another footnote to say "VREFH_ADCn has a differential voltage of +/-100mV".
- In section "Operating Conditions", for "LPDDR4 I/O voltage supply" typ value added as 1.1V.
- In section "Operating Conditions", footnote attached to IINJ_D is updated "IINJ_D specifications are per pin for an unpowered..." and removed one "GPIO electrical specifications and ...".
- In section "Operating Conditions", added paragraph "The device hardware design guide summarizes ...".
- In section "Clock frequency ranges", removed some non applicable clocks.
- In section "Clock frequency ranges", for Symbol fA53_CORE_DIV2_CLK is updated to 655.5 MHz.
- In section "Clock frequency ranges", for Symbol fA53_CORE_DIV10_CLK is updated to 131.1 MHz.
- In section "Clock frequency ranges", for Symbol fXBAR_2X_CLK min added as 48 MHz.
- In section "Clock frequency ranges", for Symbol fPFE_MAC_2_TX_CLK and fPFE_MAC_2_RX_CLK max updated to 312.5 MHz.
- In section "Clock frequency ranges", for Symbol fSDHC_CLK min updated to 133 MHz.
- In section "Thermal Characteristics", added values.
- In section "Total power specifications for 0.8V and 1.8V Analog Domains", added 0.8V values.

Table continues on the next page...

Rev 1, Nov 2021

- In section "power sequencing" updated steps 3 and 4 and added note "For step 4, it is acceptable for the 1.8V ..."
- In section "Power sequencing", added a figure "1.8V supply timing with respect to PMIC_VDD_OK during Standby Mode Exit".
- In section "Aurora Pads", Symbol "VCM_LVDS_RX" and "VDIFF_LVDS_RX" is added.
- In section "PMC Bandgap", values added.
- In section "SAR ADC", added footnote to VAD_INPUT "The reduced limits for VAD_INPUT".
- In section "DFS", Symbol "fDFS_CORE_CLK2" and "fDFS_PER_CLK5" are removed.
- In section "DFS", formula is moved from footnote to sentence with some clarifications.
- In section "DFS", for Symbol "fDFS_PER_CLK2" max updated to 628 MHz and fDFS_CLKIN max updated to 2622 MHz.
- In section "FXOSC", added specs "VIH_EXTAL", "VIL_EXTAL", "CLOAD", "VCM_SE"
- In section "FXOSC", removed differential bypass mode specs which includes fBYP_DIFF and related figure.
- In section "PLL", removed Δf_{PLL_MOD} spec and all specs "with center-spread enabled" in condition column. Added a footnote to specs which have "without center-spread enabled" in the condition column as "The max frequency in case of center-spread SSCG...".
- In section "PLL" added footnote to fPLL_CORE_VCO, fPLL_ACCEL_VCO and fPLL_DDR_VCO as "Same min frequency value applies for center-spread...".
- In section "PLL", for Symbol "fPLL_CORE_VCO" with condition "without center-spread SSCG enabled" Max changed from "2600" to "2622".
- In section "PLL", for Symbol "fPLL_PER_PHI5" with condition "PERIPH_PLL_PHI5" Max changed from "500" to "125".
- In section "PLL", for Symbol "fPLL_ACCEL_VCO" with condition "without center-spread SSCG enabled" Max changed from "2436" to "2400".
- In section "PLL", for Symbol "fPLL_CORE_PHI0" max updated to 1311 MHz.
- In section "SPI", for Symbol "tSUI" with condition "Master, MTFE=1, CPHA=0, SMPL_PTR = 1" footnote value added "N is number of protocol clock cycles whe...".
- In section "FlexRay - TxD", a missing spec is added "dCCTxD10".
- In all QuadSPI modes, moved footnote "Clock measurements done with respect to VDD_IO_QSPI/2 level." to top of the table
- In section "QuadSPI Quad 1.8V DDR 66MHz", Symbol "tISU_SCK" and "tIH_SCK" are deleted.
- In section "QuadSPI Quad 1.8V DDR 66MHz" added tLSKEW.
- In section "QuadSPI Octal 1.8V DDR 100MHz", Symbol "tCK2CKmin", "tCK2CKmax", "tIH_PCS" and "tISU_PCS" are deleted.
- In section "QuadSPI Octal 1.8V DDR 133MHz", Symbol "tCK2CKmin" and "tCK2CKmax" are deleted.
- In section "QuadSPI Quad 3.3V DDR 66MHz", Symbol "tISU_SCK" and "tIH_SCK" are deleted.
- In section "QuadSPI Quad 3.3V DDR 66MHz", Symbol "tLSKEW" is added.
- In section "QuadSPI Octal 1.8V DDR 166MHz/200MHz", updated SRE.
- In all QuadSPI sections updated TCSS and TCSH value is updated to 3.
- Section "QuadSPI interfaces" and "QuadSPI configurations" are updated.

Table continues on the next page...

Rev 1, Nov 2021
<ul style="list-style-type: none">• In section DDR, added paragraph "DDR operation with the standards stated..." and "LPDDR4 routing constraints are documented ..."• In section "uSDHC DDR-HS400" added min value to 133 MHz.• In section "JTAG Boundary Scan", updated "The SRE[2:0]=100 or SRE[2:0]=101 is required drive setting to meet the timing."• In section "SWD electrical specifications", SRE updated to SRE[2:0]=100.• Added section "Packaging".• Updated "Security" and "Suitability for use" disclaimers.
Rev 1 Draft E, July 2021
<ul style="list-style-type: none">• Subsequent updates throughout the data sheet.
Rev 1 Draft D, Apr 2021
<ul style="list-style-type: none">• Subsequent updates throughout the data sheet.
Rev 1 Draft C, Jan 2021
<ul style="list-style-type: none">• Subsequent updates throughout the data sheet.
Rev 1 Draft B, Apr 2020
<ul style="list-style-type: none">• Subsequent updates throughout the data sheet.
Rev 1 Draft A, Feb 2020
<ul style="list-style-type: none">• Initial release.

Legal information

Data sheet status

Document status ^{[1][2]}	Product status ^[3]	Definition
Objective [short] data sheet	Development	This document contains data from the objective specification for product development.
Preliminary [short] data sheet	Qualification	This document contains data from the preliminary specification.
Product [short] data sheet	Production	This document contains the product specification.

[1] Please consult the most recently issued document before initiating or completing a design.

[2] The term 'short data sheet' is explained in section "Definitions".

[3] The product status of device(s) described in this document may have changed since this document was published and may differ in case of multiple devices. The latest product status information is available on the Internet at URL <http://www.nxp.com>.

Definitions

Draft — A draft status on a document indicates that the content is still under internal review and subject to formal approval, which may result in modifications or additions. NXP Semiconductors does not give any representations or warranties as to the accuracy or completeness of information included in a draft version of a document and shall have no liability for the consequences of use of such information.

Short data sheet — A short data sheet is an extract from a full data sheet with the same product type number(s) and title. A short data sheet is intended for quick reference only and should not be relied upon to contain detailed and full information. For detailed and full information see the relevant full data sheet, which is available on request via the local NXP Semiconductors sales office. In case of any inconsistency or conflict with the short data sheet, the full data sheet shall prevail.

Product specification — The information and data provided in a Product data sheet shall define the specification of the product as agreed between NXP Semiconductors and its customer, unless NXP Semiconductors and customer have explicitly agreed otherwise in writing. In no event however, shall an agreement be valid in which the NXP Semiconductors product is deemed to offer functions and qualities beyond those described in the Product data sheet.

Disclaimers

Limited warranty and liability — Information in this document is believed to be accurate and reliable. However, NXP Semiconductors does not give any representations or warranties, expressed or implied, as to the accuracy or completeness of such information and shall have no liability for the consequences of use of such information. NXP Semiconductors takes no responsibility for the content in this document if provided by an information source outside of NXP Semiconductors.

In no event shall NXP Semiconductors be liable for any indirect, incidental, punitive, special or consequential damages (including - without limitation - lost profits, lost savings, business interruption, costs related to the removal or replacement of any products or rework charges) whether or not such damages are based on tort (including negligence), warranty, breach of contract or any other legal theory.

Notwithstanding any damages that customer might incur for any reason whatsoever, NXP Semiconductors' aggregate and cumulative liability towards customer for the products described herein shall be limited in accordance with the Terms and conditions of commercial sale of NXP Semiconductors.

Right to make changes — NXP Semiconductors reserves the right to make changes to information published in this document, including without limitation specifications and product descriptions, at any time and without notice. This document supersedes and replaces all information supplied prior to the publication hereof.

Applications — Applications that are described herein for any of these products are for illustrative purposes only. NXP Semiconductors makes no representation or warranty that such applications will be suitable for the specified use without further testing or modification.

Customers are responsible for the design and operation of their applications and products using NXP Semiconductors products, and NXP Semiconductors accepts no liability for any assistance with applications or customer product design. It is customer's sole responsibility to determine whether the NXP Semiconductors product is suitable and fit for the customer's applications and products planned, as well as for the planned application and use of customer's third party customer(s). Customers should provide appropriate design and operating safeguards to minimize the risks associated with their applications and products.

NXP Semiconductors does not accept any liability related to any default, damage, costs or problem which is based on any weakness or default in the customer's applications or products, or the application or use by customer's third party customer(s). Customer is responsible for doing all necessary testing for the customer's applications and products using NXP Semiconductors products in order to avoid a default of the applications and the products or of the application or use by customer's third party customer(s). NXP does not accept any liability in this respect.

Limiting values — Stress above one or more limiting values (as defined in the Absolute Maximum Ratings System of IEC 60134) will cause permanent damage to the device. Limiting values are stress ratings only and (proper) operation of the device at these or any other conditions above those given in the Recommended operating conditions section (if present) or the Characteristics sections of this document is not warranted. Constant or repeated exposure to limiting values will permanently and irreversibly affect the quality and reliability of the device.

Terms and conditions of commercial sale — NXP Semiconductors products are sold subject to the general terms and conditions of commercial sale, as published at <http://www.nxp.com/profile/terms>, unless otherwise agreed in a valid written individual agreement. In case an individual agreement is concluded only the terms and conditions of the respective agreement shall apply. NXP Semiconductors hereby expressly objects to applying the customer's general terms and conditions with regard to the purchase of NXP Semiconductors products by customer.

No offer to sell or license — Nothing in this document may be interpreted or construed as an offer to sell products that is open for acceptance or the grant, conveyance or implication of any license under any copyrights, patents or other industrial or intellectual property rights.

Quick reference data — The Quick reference data is an extract of the product data given in the Limiting values and Characteristics sections of this document, and as such is not complete, exhaustive or legally binding.

Export control — This document as well as the item(s) described herein may be subject to export control regulations. Export might require a prior authorization from competent authorities.

Translations — A non-English (translated) version of a document, including the legal information in that document, is for reference only. The English version shall prevail in case of any discrepancy between the translated and English versions.

Security — Customer understands that all NXP products may be subject to unidentified vulnerabilities or may support established security standards or specifications with known limitations. Customer is responsible for the design and operation of its applications and products throughout their lifecycles to reduce the effect of these vulnerabilities on customer's applications and products. Customer's responsibility also extends to other open and/or proprietary technologies supported by NXP products for use in customer's applications. NXP accepts no liability for any vulnerability. Customer should regularly check security updates from NXP and follow up appropriately.

Customer shall select products with security features that best meet rules, regulations, and standards of the intended application and make the ultimate design decisions regarding its products and is solely responsible for compliance with all legal, regulatory, and security related requirements concerning its products, regardless of any information or support that may be provided by NXP.

NXP has a Product Security Incident Response Team (PSIRT) (reachable at PSIRT@nxp.com) that manages the investigation, reporting, and solution release to security vulnerabilities of NXP products.

Suitability for use in automotive applications (functional safety) — This NXP product has been qualified for use in automotive applications. It has been developed in accordance with ISO 26262, and has been ASIL classified accordingly. If this product is used by customer in the development of, or for incorporation into, products or services (a) used in safety critical applications or (b) in which failure could lead to death, personal injury, or severe physical or environmental damage (such products and services hereinafter referred to as "Critical Applications"), then customer makes the ultimate design decisions regarding its products and is solely responsible for compliance with all legal, regulatory, safety, and security related requirements concerning its products, regardless of any information or support that may be provided by NXP. As such, customer assumes all risk related to use of any products in Critical Applications and NXP and its suppliers shall not be liable for any such use by customer. Accordingly, customer will indemnify and hold NXP harmless from any claims, liabilities, damages and associated costs and expenses (including attorneys' fees) that NXP may incur related to customer's incorporation of any product in a Critical Application.

Trademarks

Notice: All referenced brands, product names, service names, and trademarks are the property of their respective owners.

NXP — wordmark and logo are trademarks of NXP B.V.

AMBA, Arm, Arm7, Arm7TDMI, Arm9, Arm11, Artisan, big.LITTLE, Cordio, CoreLink, CoreSight, Cortex, DesignStart, DynamiQ, Jazelle, Keil, Mali, Mbed, Mbed Enabled, NEON, POP, RealView, SecurCore, Socrates, Thumb, TrustZone, ULINK, ULINK2, ULINK-ME, ULINK-PLUS, ULINKpro, μ Vision, Versatile — are trademarks and/or registered trademarks of Arm Limited (or its subsidiaries or affiliates) in the US and/or elsewhere. The related technology may be protected by any or all of patents, copyrights, designs and trade secrets. All rights reserved.

Airfast — is a trademark of NXP B.V.

CodeWarrior — is a trademark of NXP B.V.

ColdFire — is a trademark of NXP B.V.

ColdFire+ — is a trademark of NXP B.V.

CoolFlux — is a trademark of NXP B.V.

CoolFlux DSP — is a trademark of NXP B.V.

DESFire — is a trademark of NXP B.V.

EdgeLock — is a trademark of NXP B.V.

EdgeScale — is a trademark of NXP B.V.

EdgeVerse — is a trademark of NXP B.V.

eIQ — is a trademark of NXP B.V.

Freescal — is a trademark of NXP B.V.

GreenChip — is a trademark of NXP B.V.

HITAG — is a trademark of NXP B.V.

ICODE and I-CODE — are trademarks of NXP B.V.

Immersiv3D — is a trademark of NXP B.V.

I2C-bus — logo is a trademark of NXP B.V.

JCOP — is a trademark of NXP B.V.

Kinetis — is a trademark of NXP B.V.

Layerscape — is a trademark of NXP B.V.

MagniV — is a trademark of NXP B.V.

Mantis — is a trademark of NXP B.V.

MIFARE — is a trademark of NXP B.V.

MIFARE Classic — is a trademark of NXP B.V.

MIFARE4Mobile — is a trademark of NXP B.V.

MIFARE Plus — is a trademark of NXP B.V.

MIFARE Ultralight — is a trademark of NXP B.V.

MiGLO — wordmark and logo are trademarks of NXP B.V.

NTAG — is a trademark of NXP B.V.

NXP SECURE CONNECTIONS FOR A SMARTER WORLD — is a trademark of NXP B.V.

PEG — is a trademark of NXP B.V.

Processor Expert — is a trademark of NXP B.V.

QorIQ — is a trademark of NXP B.V.

QorIQ Qonverge — is a trademark of NXP B.V.

RoadLINK — wordmark and logo are trademarks of NXP B.V.

SafeAssure — is a trademark of NXP B.V.

SafeAssure — logo is a trademark of NXP B.V.

SmartMX — is a trademark of NXP B.V.

Synopsys & Designware — are registered trademarks of Synopsys, Inc.

Synopsys — Portions Copyright © 2021 Synopsys, Inc. Used with permission. All rights reserved.

Tower — is a trademark of NXP B.V.

UCODE — is a trademark of NXP B.V.

VortiQa — is a trademark of NXP B.V.



arm

Please be aware that important notices concerning this document and the product(s) described herein, have been included in section 'Legal information'.

© NXP B.V. 2023.

All rights reserved.

For more information, please visit: <http://www.nxp.com>

For sales office addresses, please send an email to: salesaddresses@nxp.com

Date of release: 02/2023
Document identifier: S32G3

Mouser Electronics

Authorized Distributor

Click to View Pricing, Inventory, Delivery & Lifecycle Information:

NXP:

[S32G378AACK1VUCT](#) [S32G379AACK1VUCT](#) [S32G398AACK1VUCT](#) [S32G399AACK1VUCT](#)
[S32G378AACK1VUCR](#) [S32G378ASCK1VUCR](#) [S32G378ASCK1VUCT](#) [S32G379AACK1VUCR](#)
[S32G379ASCK1VUCR](#) [S32G379ASCK1VUCT](#) [S32G398AAAK1VUCT](#) [S32G398AABK1VUCT](#) [S32G398AACK1VUCR](#)
[S32G398ASAK1VUCT](#) [S32G398ASBK1VUCT](#) [S32G398ASCK1VUCR](#) [S32G398ASCK1VUCT](#)
[S32G399AAAK1VUCT](#) [S32G399AABK1VUCT](#) [S32G399AACK1VUCR](#) [S32G399ASAK1VUCT](#) [S32G399ASBK1VUCT](#)
[S32G399ASCK1VUCR](#) [S32G399ASCK1VUCT](#) [S32G378ASAK1VUCR](#) [S32G378ASAK1VUCT](#)

Looking for pricing, stock, or lifecycle information?

Click below to explore more details on WIN SOURCE:

 [View S32G399AACK1VUCT on WIN SOURCE](#)

 [NXP / Nexperia Information](#)

Optimize Your Supply Chain with WIN SOURCE Solutions

-  Global Sourcing Solution
-  Obsolete Management
-  Cost Control Management
-  Shortage Management
-  Alternative Solution
-  Excess Inventory Management