



THE DATASHEET OF ESP32-C3-DEVKITM-1



ESP32-C3 Series

Datasheet

Ultra-Low-Power SoC with RISC-V Single-Core CPU
2.4 GHz Wi-Fi (802.11b/g/n) and Bluetooth® 5 (LE)
Optional 4 MB flash in the chip's package
QFN32 (5×5 mm) package

Including:

ESP32-C3

ESP32-C3FN4 – End of life

ESP32-C3FH4

ESP32-C3FH4AZ – [Not Recommended for New Designs \(NRND\)](#)

ESP32-C3FH4X – Recommended

ESP32-C3FH4XAZ



Version 1.7
Espressif Systems
Copyright © 2024

Product Overview

ESP32-C3 is an low-power and highly-integrated MCU-based solution that supports 2.4 GHz Wi-Fi and Bluetooth® Low Energy (Bluetooth LE).

The functional block diagram of the SoC is shown below.

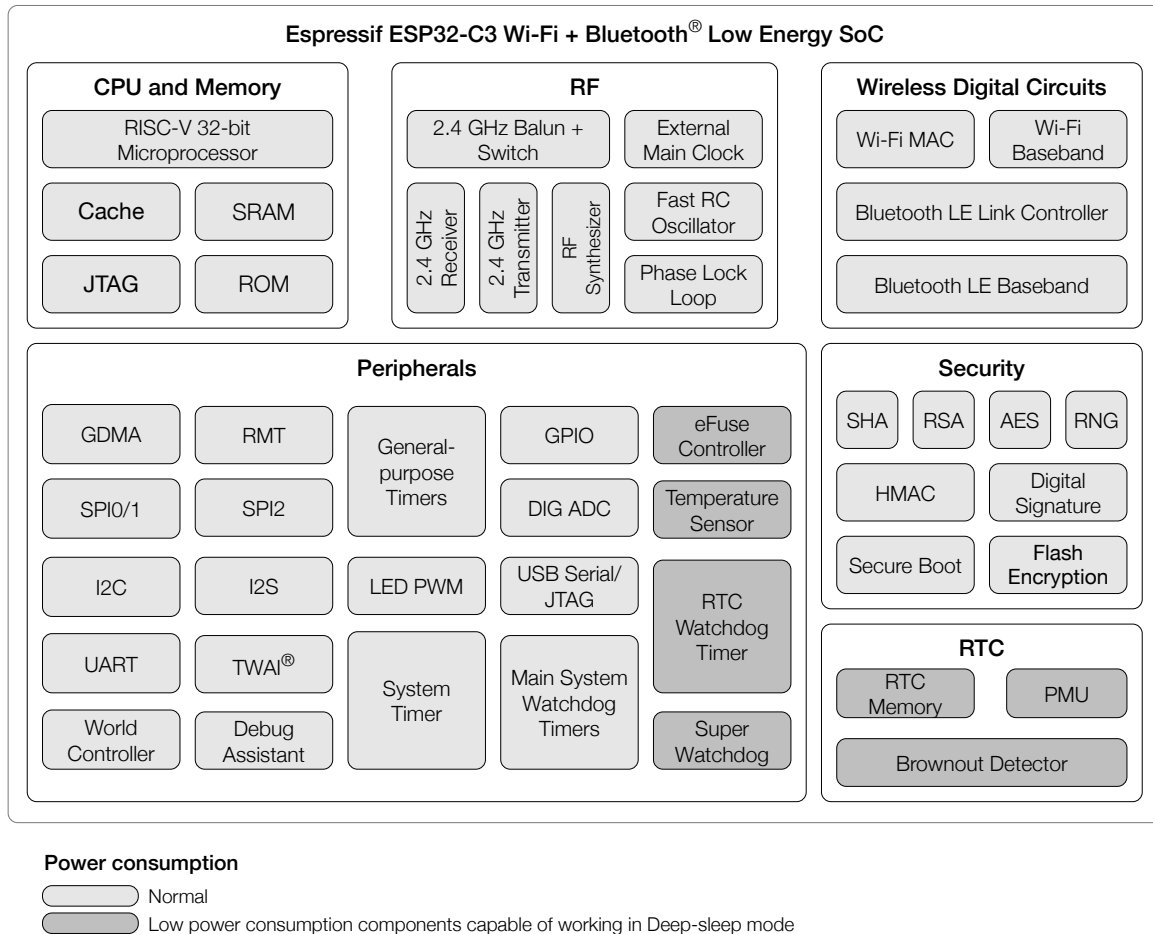

ESP32-C3 Functional Block Diagram

For more information on power consumption, see Section [3.7 Power Management](#).

Features

Wi-Fi

- IEEE 802.11b/g/n-compliant
- Supports 20 MHz, 40 MHz bandwidth in 2.4 GHz band
- 1T1R mode with data rate up to 150 Mbps
- Wi-Fi Multimedia (WMM)
- TX/RX A-MPDU, TX/RX A-MSDU
- Immediate Block ACK
- Fragmentation and defragmentation
- Transmit opportunity (TXOP)
- Automatic Beacon monitoring (hardware TSF)
- 4 × virtual Wi-Fi interfaces
- Simultaneous support for Infrastructure BSS in Station mode, SoftAP mode, Station + SoftAP mode, and promiscuous mode
Note that when ESP32-C3 scans in Station mode, the SoftAP channel will change along with the Station channel
- Antenna diversity
- 802.11mc FTM

Bluetooth®

- Bluetooth LE: Bluetooth 5, Bluetooth mesh
- High power mode (20 dBm)
- Speed: 125 Kbps, 500 Kbps, 1 Mbps, 2 Mbps
- Advertising extensions
- Multiple advertisement sets
- Channel selection algorithm #2
- Internal co-existence mechanism between Wi-Fi and Bluetooth to share the same antenna

CPU and Memory

- 32-bit RISC-V single-core processor, up to 160 MHz
- CoreMark® score:
 - 1 core at 160 MHz: 407.22 CoreMark; 2.55 CoreMark/MHz
- 384 KB ROM
- 400 KB SRAM (16 KB for cache)

- 8 KB SRAM in RTC
- In-package flash (see details in Chapter 1 [ESP32-C3 Series Comparison](#))
- SPI, Dual SPI, Quad SPI, and QPI interfaces that allow connection to multiple off-package flash
- Access to flash accelerated by cache
- Supports flash in-Circuit Programming (ICP)

Advanced Peripheral Interfaces

- 22 or 16 programmable GPIOs
- Digital interfaces:
 - 3 × SPI
 - 2 × UART
 - 1 × I2C
 - 1 × I2S
 - Remote control peripheral, with 2 transmit channels and 2 receive channels
 - LED PWM controller, with up to 6 channels
 - Full-speed USB Serial/JTAG controller
 - General DMA controller (GDMA), with 3 transmit channels and 3 receive channels
 - 1 × TWAI[®] controller compatible with ISO 11898-1 (CAN Specification 2.0)
- Analog interfaces:
 - 2 × 12-bit SAR ADCs, up to 6 channels
 - 1 × temperature sensor
- Timers:
 - 2 × 54-bit general-purpose timers
 - 3 × digital watchdog timers
 - 1 × analog watchdog timer
 - 1 × 52-bit system timer

Power Management

- Fine-resolution power control through a selection of clock frequency, duty cycle, Wi-Fi operating modes, and individual power control of internal components
- Four power modes designed for typical scenarios: Active, Modem-sleep, Light-sleep, Deep-sleep
- Power consumption in Deep-sleep mode is 5 μ A
- RTC memory remains powered on in Deep-sleep mode

Security

- Secure boot - permission control on accessing internal and external memory
- Flash encryption - memory encryption and decryption
- 4096-bit OTP, up to 1792 bits for users
- Cryptographic hardware acceleration:
 - AES-128/256 (FIPS PUB 197)
 - SHA Accelerator (FIPS PUB 180-4)
 - RSA Accelerator
 - Random Number Generator (RNG)
 - HMAC
 - Digital signature

RF Module

- Antenna switches, RF balun, power amplifier, low-noise receive amplifier
- Up to +21 dBm of power for an 802.11b transmission
- Up to +20 dBm of power for an 802.11n transmission
- Up to -105 dBm of sensitivity for Bluetooth LE receiver (125 Kbps)

Applications

With low power consumption, ESP32-C3 is an ideal choice for IoT devices in the following areas:

- Smart Home
- Industrial Automation
- Health Care
- Consumer Electronics
- Smart Agriculture
- POS Machines
- Service Robot
- Audio Devices
- Generic Low-power IoT Sensor Hubs
- Generic Low-power IoT Data Loggers

Note:

Check the link or the QR code to make sure that you use the latest version of this document:
https://www.espressif.com/documentation/esp32-c3_datasheet_en.pdf



Contents

Product Overview	2
Features	3
Applications	5
1 ESP32-C3 Series Comparison	11
1.1 Nomenclature	11
1.2 Comparison	11
2 Pins	12
2.1 Pin Layout	12
2.2 Pin Overview	14
2.3 IO Pins	17
2.3.1 IO MUX and GPIO Functions	17
2.3.2 Analog Functions	19
2.3.3 Restrictions for GPIOs	20
2.4 Analog Pins	21
2.5 Power Supply	22
2.5.1 Power Pins	22
2.5.2 Power Scheme	22
2.5.3 Chip Power-up and Reset	23
2.6 Strapping Pins	25
2.6.1 Chip Boot Mode Control	26
2.6.2 ROM Messages Printing Control	26
2.7 Pin Mapping Between Chip and Flash	28
3 Functional Description	29
3.1 CPU and Memory	29
3.1.1 CPU	29
3.1.2 Internal Memory	29
3.1.3 Off-package Flash	29
3.1.4 Address Mapping Structure	30
3.1.5 Cache	31
3.2 System Clocks	31
3.2.1 CPU Clock	31
3.2.2 RTC Clock	31
3.3 Analog Peripherals	32

3.3.1	Analog-to-Digital Converter (ADC)	32
3.3.2	Temperature Sensor	32
3.4	Digital Peripherals	32
3.4.1	General Purpose Input / Output Interface (GPIO)	32
3.4.2	Serial Peripheral Interface (SPI)	33
3.4.3	Universal Asynchronous Receiver Transmitter (UART)	33
3.4.4	I2C Interface	34
3.4.5	I2S Interface	34
3.4.6	Remote Control Peripheral	34
3.4.7	LED PWM Controller	35
3.4.8	General DMA Controller	35
3.4.9	USB Serial/JTAG Controller	35
3.4.10	TWAI® Controller	35
3.5	Radio and Wi-Fi	36
3.5.1	2.4 GHz Receiver	36
3.5.2	2.4 GHz Transmitter	36
3.5.3	Clock Generator	37
3.5.4	Wi-Fi Radio and Baseband	37
3.5.5	Wi-Fi MAC	37
3.5.6	Networking Features	38
3.6	Bluetooth LE	38
3.6.1	Bluetooth LE Radio and PHY	38
3.6.2	Bluetooth LE Link Layer Controller	38
3.7	Power Management	39
3.8	Timers	40
3.8.1	General Purpose Timers	41
3.8.2	System Timer	41
3.8.3	Watchdog Timers	41
3.9	Cryptographic Hardware Accelerators	42
3.10	Physical Security Features	42
3.11	Peripheral Pin Configurations	43
4	Electrical Characteristics	45
4.1	Absolute Maximum Ratings	45
4.2	Recommended Operating Conditions	45
4.3	VDD_SPI Output Characteristics	46
4.4	DC Characteristics (3.3 V, 25 °C)	46
4.5	ADC Characteristics	47
4.6	Current Consumption	47
4.6.1	RF Current Consumption in Active Mode	47
4.6.2	Current Consumption in Other Modes	48
4.7	Reliability	48
4.8	Wi-Fi Radio	49
4.8.1	Wi-Fi RF Transmitter (TX) Specifications	49
4.8.2	Wi-Fi RF Receiver (RX) Specifications	50
4.9	Bluetooth LE Radio	51

4.9.1	Bluetooth LE RF Transmitter (TX) Specifications	51
4.9.2	Bluetooth LE RF Receiver (RX) Specifications	53
5	Packaging	56
	Appendix A – ESP32-C3 Consolidated Pin Overview	57
	Related Documentation and Resources	58
	Revision History	59

List of Tables

1-1	ESP32-C3 Series Comparison	11
2-1	Pin Overview	15
2-2	Power-Up Glitches on Pins	16
2-3	IO MUX Pin Functions	18
2-4	RTC and Analog Functions	19
2-5	Analog Pins	21
2-6	Power Pins	22
2-7	Voltage Regulators	22
2-8	Description of Timing Parameters for Power-up and Reset	24
2-9	Default Configuration of Strapping Pins	25
2-10	Description of Timing Parameters for the Strapping Pins	25
2-11	Chip Boot Mode Control	26
2-12	ROM Messages Printing Control	27
2-13	Pin Mapping Between Chip and In-package Flash	28
3-1	Components and Power Domains	40
3-2	Peripheral Pin Configurations	43
4-1	Absolute Maximum Ratings	45
4-2	Recommended Operating Conditions	45
4-3	VDD_SPI Internal and Output Characteristics	46
4-4	DC Characteristics (3.3 V, 25 °C)	46
4-5	ADC Characteristics	47
4-6	ADC Calibration Results	47
4-7	Wi-Fi Current Consumption Depending on RF Modes	47
4-8	Current Consumption in Modem-sleep Mode	48
4-9	Current Consumption in Low-Power Modes	48
4-10	Reliability Qualifications	48
4-11	Wi-Fi Frequency	49
4-12	TX Power with Spectral Mask and EVM Meeting 802.11 Standards	49
4-13	TX EVM Test	49
4-14	RX Sensitivity	50
4-15	Maximum RX Level	50
4-16	RX Adjacent Channel Rejection	51
4-17	Bluetooth LE Frequency	51
4-18	Transmitter Characteristics - Bluetooth LE 1 Mbps	51
4-19	Transmitter Characteristics - Bluetooth LE 2 Mbps	52
4-20	Transmitter Characteristics - Bluetooth LE 125 Kbps	52
4-21	Transmitter Characteristics - Bluetooth LE 500 Kbps	52
4-22	Receiver Characteristics - Bluetooth LE 1 Mbps	53
4-23	Receiver Characteristics - Bluetooth LE 2 Mbps	53
4-24	Receiver Characteristics - Bluetooth LE 125 Kbps	54
4-25	Receiver Characteristics - Bluetooth LE 500 Kbps	55

List of Figures

1-1	ESP32-C3 Series Nomenclature	11
2-1	ESP32-C3 Pin Layout (Top View)	12
2-2	ESP32-C3FH4AZ Pin Layout (Top View)	13
2-3	ESP32-C3 Power Scheme	23
2-4	Visualization of Timing Parameters for Power-up and Reset	23
2-5	Visualization of Timing Parameters for the Strapping Pins	26
3-1	Address Mapping Structure	30
3-2	Components and Power Domains	40
5-1	QFN32 (5×5 mm) Package	56

1 ESP32-C3 Series Comparison

1.1 Nomenclature

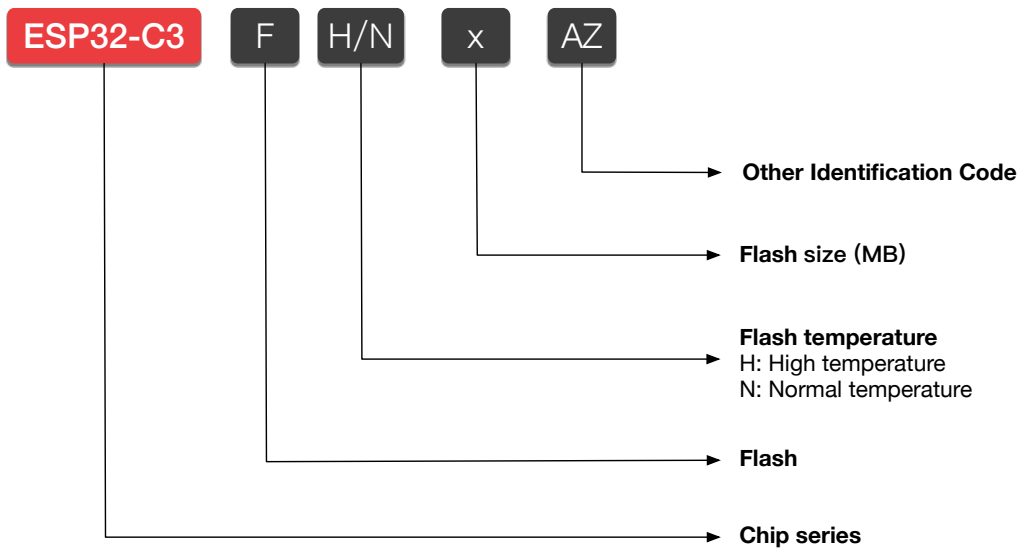

Figure 1-1. ESP32-C3 Series Nomenclature

1.2 Comparison

Table 1-1. ESP32-C3 Series Comparison

Ordering Code ¹	In-Package Flash	Ambient Temp. ² (°C)	Package (mm)	GPIO No. ⁴	Chip Revision ⁵
ESP32-C3 ³	—	−40 ~ 105	QFN32 (5*5)	22	v0.4
ESP32-C3FN4 (End of life)	4 MB	−40 ~ 85	QFN32 (5*5)	22	v0.4
ESP32-C3FH4	4 MB	−40 ~ 105	QFN32 (5*5)	22	v0.4
ESP32-C3FH4AZ (NRND)	4 MB	−40 ~ 105	QFN32 (5*5)	16	v0.4
ESP32-C3FH4X (Recommended)	4 MB	−40 ~ 105	QFN32 (5*5)	22	v1.1
ESP32-C3FH4XAZ	4 MB	−40 ~ 105	QFN32 (5*5)	16	v1.1

¹ For details on chip marking and packing, see Section [5 Packaging](#).

² Ambient temperature specifies the recommended temperature range of the environment immediately outside an Espressif chip.

³ ESP32-C3 requires an SPI flash off the chip's package. For details about SPI modes, see Section [2.7 Pin Mapping Between Chip and Flash](#).

⁴ SPIO/SPI1 pins for flash connection are not bonded for variants with 16 GPIOs.

⁵ All chip revisions have the same SRAM size, but chip revision v1.1 (i.e. ESP32-C3FH4X and ESP32-C3FH4XAZ) has around 35 KB more available space for users than chip revision v0.4. For how to identify chip revisions, please refer to [ESP32-C3 Errata](#).

2 Pins

2.1 Pin Layout

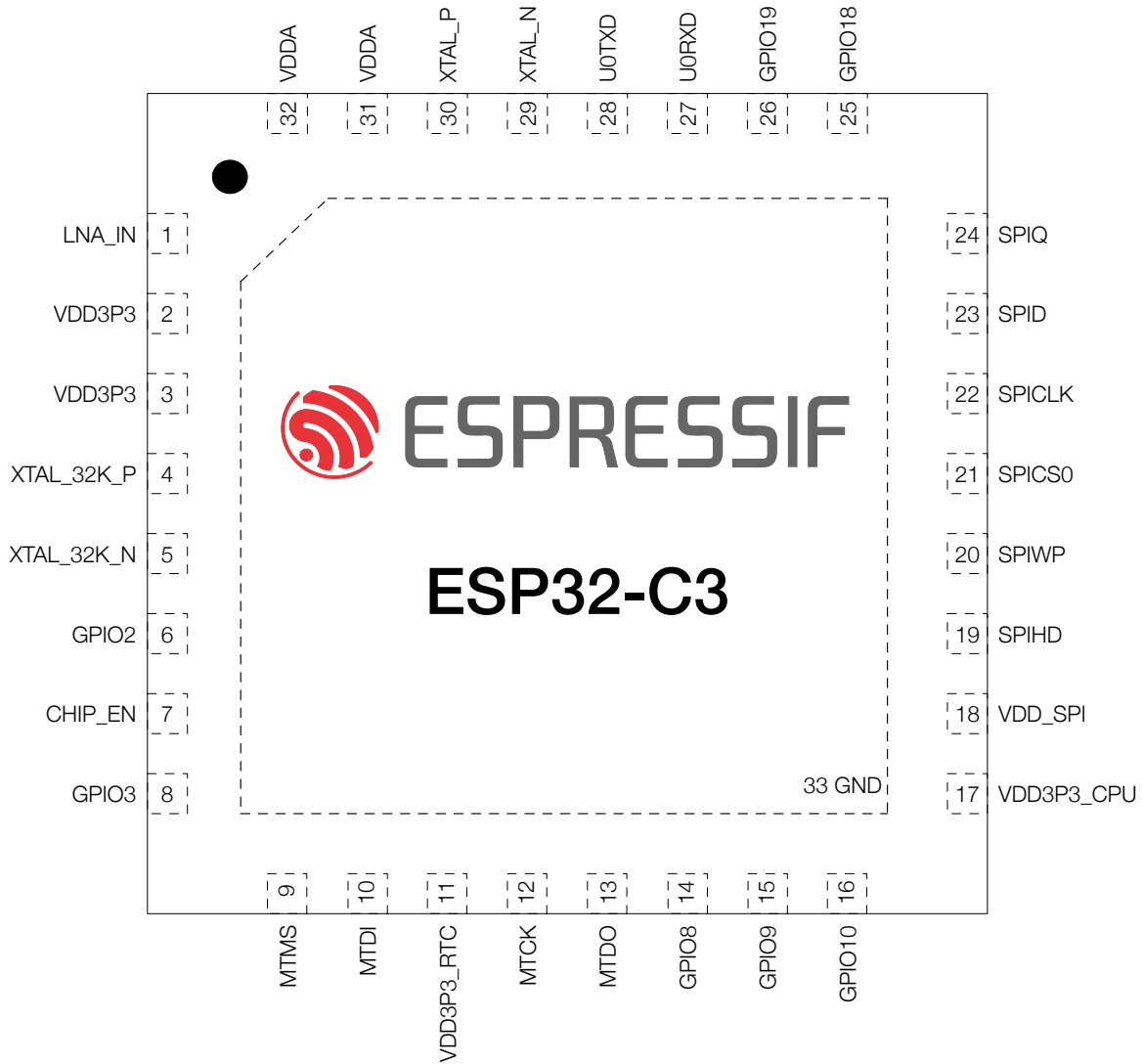

Figure 2-1. ESP32-C3 Pin Layout (Top View)

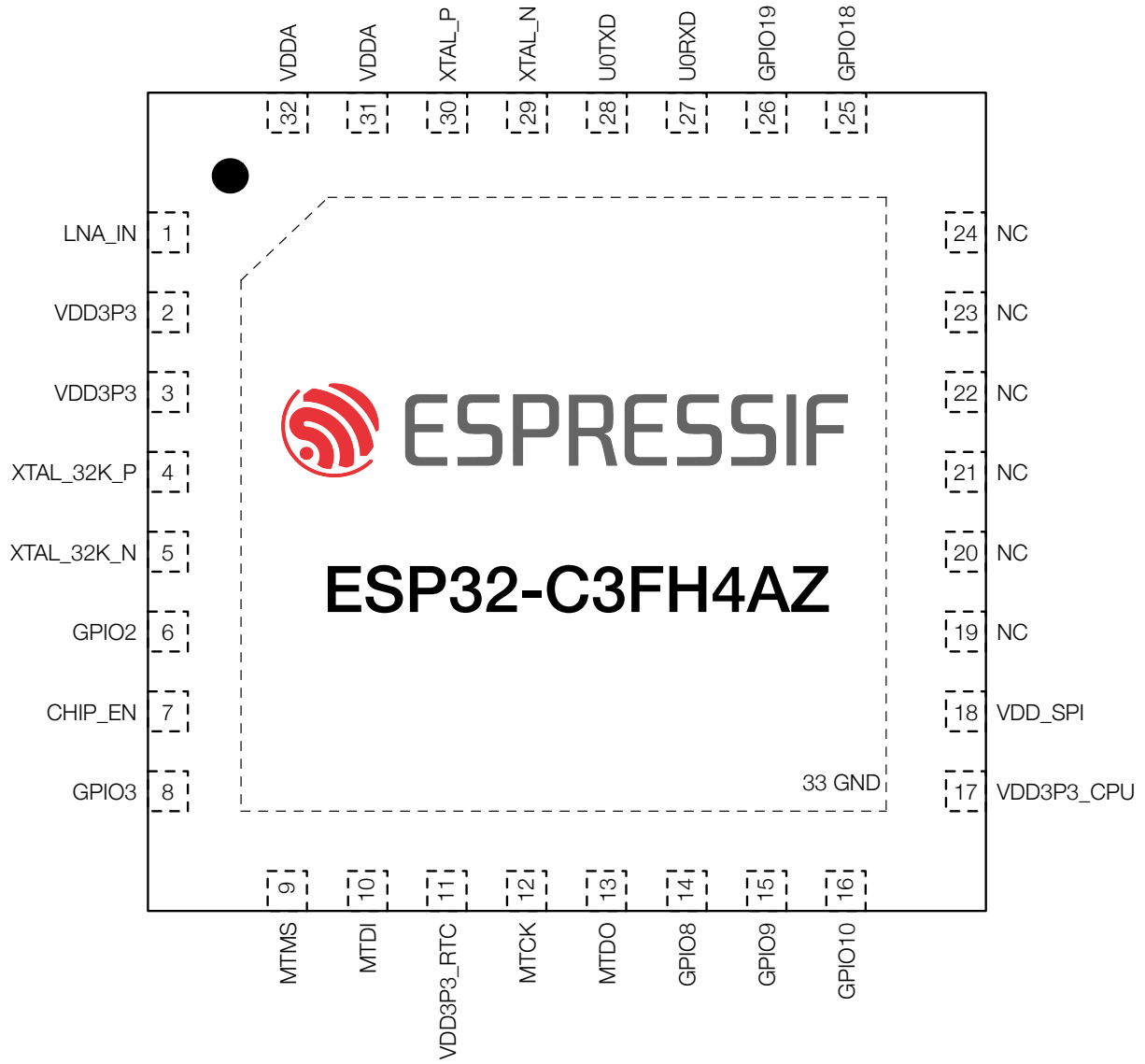

Figure 2-2. ESP32-C3FH4AZ Pin Layout (Top View)

2.2 Pin Overview

The ESP32-C3 chip integrates multiple peripherals that require communication with the outside world. To keep the chip package size reasonably small, the number of available pins has to be limited. So the only way to route all the incoming and outgoing signals is through pin multiplexing. Pin muxing is controlled via software programmable registers (see [ESP32-C3 Technical Reference Manual](#) > Chapter *IO MUX and GPIO Matrix*).

All in all, the ESP32-C3 chip has the following types of pins:

- **IO pins** with the following predefined sets of functions to choose from:
 - **Each** IO pin has predefined **IO MUX and GPIO functions** – see Table [2-3 IO MUX and GPIO Functions](#)
 - **Some** IO pins have predefined **analog functions** – see Table [2-4 Analog Functions](#)

Predefined functions means that each IO pin has a set of direct connections to certain on-chip components. During run-time, the user can configure which component from a predefined set to connect to a certain pin at a certain time via memory mapped registers (see the TRM).

- **Analog pins** that have exclusively-dedicated **analog functions** – see Table [2-5 Analog Pins](#)
- **Power pins** supply power to the chip components and non-power pins – see Table [2-6 Power Pins](#)

Notes for Table 2-1 Pin Overview (see below):

1. For more information, see respective sections below. Alternatively, see [Appendix A – ESP32-C3 Consolidated Pin Overview](#).
2. **Bold** marks the pin function set in which a pin has its default function in the default boot mode. See Section [2.6.1 Chip Boot Mode Control](#).
3. In column **Pin Providing Power**, regarding pins powered by VDD_SPI:
 - Power actually comes from the internal power rail supplying power to VDD_SPI. For details, see Section [2.5.2 Power Scheme](#).
4. In column **Pin Providing Power**, regarding pins powered by VDD3P3_CPU / VDD_SPI:
 - Pin Providing Power (either VDD3P3_CPU or VDD_SPI) can be configured via a register, see [ESP32-C3 Technical Reference Manual](#) > Chapter *IO MUX and GPIO pins*.
5. Except for GPIO18 and GPIO19 whose default drive strength is 40 mA, the default drive strength for all the other pins is 20 mA.
6. Column **Pin Settings** shows predefined settings at reset and after reset with the following abbreviations:
 - IE – input enabled
 - WPU – internal weak pull-up resistor enabled
 - WPD – internal weak pull-down resistor enabled
 - USB_PU – USB pull-up resistor enabled
 - By default, the USB function is enabled for USB pins (i.e., GPIO18 and GPIO19), and the pin pull-up is decided by the USB pull-up resistor. The USB pull-up resistor is controlled by USB_SERIAL_JTAG_DP/DM_PULLUP and the pull-up value is controlled by

USB_SERIAL_JTAG_PULLUP_VALUE. For details, see [ESP32-C3 Technical Reference Manual](#) > Chapter *USB Serial/JTAG Controller*)

- When the USB function is disabled, USB pins are used as regular GPIOs and the pin's internal weak pull-up and pull-down resistors are disabled by default (configurable by IO_MUX_FUN_WPU/WPD)

7. Depends on the value of EFUSE_DIS_PAD_JTAG

- 0 - default value. Input enabled, and internal weak pull-up resistor enabled (IE & WPU)
- 1 - input enabled (IE)

8. Output enabled

9. By default VDD_SPI is the power supply pin for in-package and off-package flash. It can be reconfigured as a GPIO pin, if the chip is connected to an off-package flash, and this flash is powered by an external power supply. For details about reconfiguration, please refer to [ESP32-C3 Technical Reference Manual](#) > Chapter *IO MUX and GPIO Matrix*.

10. For ESP32-C3FH4AZ, pins within the frame (namely pin 19 ~ pin 24) are not bonded, and are labelled as "not connected".

Table 2-1. Pin Overview

Pin No.	Pin Name	Pin Type ¹	Pin Providing Power ³⁻⁵	Pin Settings ⁶		Pin Function Sets ^{1,2}	
				At Reset	After Reset	IO MUX	Analog
1	LNA_IN	Analog					
2	VDD3P3	Power					
3	VDD3P3	Power					
4	XTAL_32K_P	IO	VDD3P3_RTC			IO MUX	Analog
5	XTAL_32K_N	IO	VDD3P3_RTC			IO MUX	Analog
6	GPIO2	IO	VDD3P3_RTC	IE	IE	IO MUX	Analog
7	CHIP_EN	Analog					
8	GPIO3	IO	VDD3P3_RTC	IE	IE	IO MUX	Analog
9	MTMS	IO	VDD3P3_RTC		IE	IO MUX	Analog
10	MTDI	IO	VDD3P3_RTC		IE	IO MUX	Analog
11	VDD3P3_RTC	Power					
12	MTCK	IO	VDD3P3_CPU		IE ⁷	IO MUX	
13	MTDO	IO	VDD3P3_CPU		IE	IO MUX	
14	GPIO8	IO	VDD3P3_CPU	IE	IE	IO MUX	
15	GPIO9	IO	VDD3P3_CPU	IE, WPU	IE, WPU	IO MUX	
16	GPIO10	IO	VDD3P3_CPU		IE	IO MUX	
17	VDD3P3_CPU	Power					
18	VDD_SPI ⁹ ¹⁰	Power	VDD3P3_CPU			IO MUX	
19	SPIHD	IO	VDD_SPI / VDD3P3_CPU	WPU	IE, WPU	IO MUX	
20	SPIWP	IO	VDD_SPI / VDD3P3_CPU	WPU	IE, WPU	IO MUX	
21	SPICSO	IO	VDD_SPI / VDD3P3_CPU	WPU	IE, WPU	IO MUX	
22	SPICLK	IO	VDD_SPI / VDD3P3_CPU	WPU	IE, WPU	IO MUX	
23	SPIID	IO	VDD_SPI / VDD3P3_CPU	WPU	IE, WPU	IO MUX	
24	SPIQ	IO	VDD_SPI / VDD3P3_CPU	WPU	IE, WPU	IO MUX	
25	GPIO18	IO	VDD3P3_CPU			IO MUX	Analog

Cont'd on next page

Table 2-1 – cont'd from previous page

Pin No.	Pin Name	Pin Type ¹	Pin Providing Power ³⁻⁵	Pin Settings ⁶		Pin Function Sets ^{1,2}	
				At Reset	After Reset	IO MUX	Analog
26	GPIO19	IO	VDD3P3_CPU		USB_PU	IO MUX	Analog
27	UORXD	IO	VDD3P3_CPU		IE, WPU	IO MUX	
28	UOTXD	IO	VDD3P3_CPU		WPU ⁸	IO MUX	
29	XTAL_N	Analog					
30	XTAL_P	Analog					
31	VDDA	Power					
32	VDDA	Power					
33	GND	Power					

Some pins have glitches during power-up. See details in Table 2-2.

Table 2-2. Power-Up Glitches on Pins

Pin	Glitch ¹	Typical Time Period(ns)
MTCK	Low-level glitch	5
MTDO	Low-level glitch	5
GPIO10	Low-level glitch	5
UORXD	Low-level glitch	5
GPIO18	High-level glitch	50000

¹ Low-level glitch: the pin is at a low level output status during the time period;

High-level glitch: the pin is at a high level output status during the time period;

Pull-down glitch: the pin is at an internal weak pulled-down status during the time period;

Pull-up glitch: the pin is at an internal weak pulled-up status during the time period.

Please refer to Table 4-4 for detailed parameters about low/high-level and pull-down/up.

2.3 IO Pins

2.3.1 IO MUX and GPIO Functions

The pins of ESP32-C3 can be assigned any function (F0-F2) from their respective sets of IO MUX functions as listed in Table 2-3 *IO MUX and GPIO Functions*.

Each set of the IO MUX functions has a general purpose input/output (**GPIO0, GPIO1, etc.**) function. If a pin is assigned a GPIO function, this pin's signal is routed via the GPIO matrix, which incorporates internal signal routing circuitry for mapping signals programmatically. It gives the pin access to almost any IO MUX function. However, the flexibility of programmatic mapping comes at a cost as it might affect speed and latency of routed signals.

Notes for Table 2-3 IO MUX and GPIO Functions:

1. **Bold** marks the default pin functions in the default boot mode. See Section 2.6.1 [Chip Boot Mode Control](#).
2. Regarding **highlighted** cells, see Section 2.3.3 [Restrictions for GPIOs](#).
3. Each IO MUX function (F_n , $n = 0 \sim 2$) is associated with a *type*. The description of *type* is as follows:
 - I – input. O – output. T – high impedance.
 - I1 – input; if the pin is assigned a function other than F_n , the input signal of F_n is always 1.
 - IO – input; if the pin is assigned a function other than F_n , the input signal of F_n is always 0.

4. Function names:

GPIO...	General-purpose input/output with signals routed via the GPIO matrix. For more details on the GPIO matrix, see ESP32-C3 Technical Reference Manual > Chapter <i>IO MUX and GPIO Matrix</i> .
U...RXD	} UART0/1 receive/transmit signals.
U...TXD	

5. Groups of functions (see the markings in the table):

- (a) JTAG interface for debugging.
- (b) UART interface for debugging.
- (c) SPI0/1 interface for connection to in-package or off-package flash via SPI bus. It supports 1-, 2-, 4-line SPI modes. See also Section 2.7 [Pin Mapping Between Chip and Flash](#).
- (d) SPI2 main interface for fast SPI connection. It supports 1-, 2-, 4-line SPI modes.

Table 2-3. IO MUX Pin Functions

Pin No.	IO MUX / GPIO Name	IO MUX Function ^{1,4}					
		0	Type ³	1	Type	2	Type
4	GPIO0	GPIO0	I/O/T	GPIO0	I/O/T		
5	GPIO1	GPIO1	I/O/T	GPIO1	I/O/T		
6	GPIO2	GPIO2	I/O/T	GPIO2	I/O/T	FSPIQ	I/O/T
8	GPIO3	GPIO3	I/O/T	GPIO3	I/O/T		
9	GPIO4	MTMS	I	GPIO4	I/O/T	FSPIHD	I/O/T
10	GPIO5	MTDI	I	GPIO5	I/O/T	FSPIWP	I/O/T
12	GPIO6	MTCK	I	GPIO6	I/O/T	FSPICLK	I/O/T
13	GPIO7	MTDO	O/T	GPIO7	I/O/T	FSPID	I/O/T
14	GPIO8	GPIO8	I/O/T	GPIO8	I/O/T		
15	GPIO9	GPIO9	I/O/T	GPIO9	I/O/T		
16	GPIO10	GPIO10	I/O/T	GPIO10	I/O/T	FSPICSO	I/O/T
18	GPIO11	GPIO11	I/O/T	GPIO11	I/O/T		
19	GPIO12	SPIHD	I/O/T	GPIO12	I/O/T		
20	GPIO13	SPIWP	I/O/T	GPIO13	I/O/T		
21	GPIO14	SPICSO	O/T	GPIO14	I/O/T		
22	GPIO15	SPICLK	O/T	GPIO15	I/O/T		
23	GPIO16	SPID	I/O/T	GPIO16	I/O/T		
24	GPIO17	SPIQ	I/O/T	GPIO17	I/O/T		
25	GPIO18	GPIO18	I/O/T	GPIO18	I/O/T		
26	GPIO19	GPIO19	I/O/T	GPIO19	I/O/T		
27	GPIO20	UORXD	I	GPIO20	I/O/T		
28	GPIO21	UOTXD	O	GPIO21	I/O/T		

2.3.2 Analog Functions

Notes for Table 2-4 Analog Functions:

1. **Bold** marks the default pin functions in the default boot mode. See Section 2.6.1 Chip Boot Mode Control.
2. Regarding **highlighted** cells, see Section 2.3.3 Restrictions for GPIOs.
3. Function names:

XTAL_32K_P	} 32 kHz external clock input/output connected to ESP32-C3's oscillator.
XTAL_32K_N	
ADC1_CH...	} Analog to digital conversion channel for ADC1 or ADC2.
ADC2_CH...	
USB_D-	} USB Serial/JTAG function. USB signal is a differential signal transmitted over a pair of D+ and D- wires.
USB_D+	

Table 2-4. RTC and Analog Functions

Pin No.	Analog IO Name	Analog Function ³	
		0	1
4	GPIO0	XTAL_32K_P	ADC1_CH0
5	GPIO1	XTAL_32K_N	ADC1_CH1
6	GPIO2		ADC1_CH2
8	GPIO3		ADC1_CH3
9	GPIO4		ADC1_CH4
10	GPIO5		ADC2_CH0
25	GPIO18	USB_D-	
26	GPIO19	USB_D+	

2.3.3 Restrictions for GPIOs

All IO pins of the ESP32-C3 have GPIO pin functions. However, the IO pins are multiplexed and have other important pin functions. This should be taken into account while certain pins are chosen for general purpose input output.

In Table [2-3 IO MUX and GPIO Functions](#) and Table [2-4 Analog Functions](#) some pin functions are highlighted. The non-highlighted GPIO pins are recommended for use first. If more pins are needed, the highlighted GPIOs should be chosen carefully to avoid conflicts with important pin functions.

The highlighted IO pins have the following important pin functions:

- **GPIO** – allocated for communication with in-package flash and NOT recommended for other uses. For details, see Section [2.7 Pin Mapping Between Chip and Flash](#).
- **GPIO** – have one of the following important functions:
 - **Strapping pins** – need to be at certain logic levels at startup. See Section [2.6 Strapping Pins](#).
 - **USB_D+/-** – by default, connected to the USB Serial/JTAG Controller. To function as GPIOs, these pins need to be reconfigured by referring to [ESP32-C3 Technical Reference Manual](#) > Chapter *IO MUX and GPIO Matrix*.
 - **JTAG interface** – often used for debugging. See Table [2-3 IO MUX and GPIO Functions](#), note [5a](#). To free these pins up, the pin functions USB_D+/- of the [ESP32-C3 Technical Reference Manual USB Serial/JTAG Controller](#) can be used instead.
 - **UART interface** – often used for debugging. See Table [2-3 IO MUX and GPIO Functions](#), note [5b](#).
 - **ADC2** – no restrictions, unless there is an on-going **Wi-Fi** connection. ADC2_CH... analog functions (see Table [2-4 Analog Functions](#)) cannot be used with Wi-Fi simultaneously.

See also [Appendix A – ESP32-C3 Consolidated Pin Overview](#).

2.4 Analog Pins

Table 2-5. Analog Pins

Pin No.	Pin Name	Pin Type	Pin Function
1	LNA_IN	I/O	Low Noise Amplifier (RF LNA) input / output signals
7	CHIP_EN	I	High: on, the chip is started up. Low: off, the chip is shut down. Note: Do not leave the CHIP_EN pin floating.
29	XTAL_N	—	External clock input/output connected to the chip's oscillator. P/N means differential clock positive/negative.
30	XTAL_P	—	

2.5 Power Supply

2.5.1 Power Pins

The chip is powered via the power pins described in Table 2-6 *Power Pins*.

Table 2-6. Power Pins

Pin No.	Pin Name	Direction	Power Supply ^{1,2}	
			Power Domain / Other	IO Pins ³
2	VDD3P3	Input	Analog power domain	
3	VDD3P3	Input	Analog power domain	
11	VDD3P3_RTC	Input	RTC and part of Digital power domains	RTC IO
17	VDD3P3_CPU	Input	Digital power domain	Digital IO
18	VDD_SPI ⁴	Input	In-package flash (backup power line)	
		Output	In-package and off-package flash	SPI IO
31	VDDA	Input	Analog power domain	
32	VDDA	Input	Analog power domain	
33	GND	—	External ground connection	

¹ See in conjunction with Section 2.5.2 *Power Scheme*.

² For recommended and maximum voltage and current, see Section 4.1 *Absolute Maximum Ratings* and Section 4.2 *Recommended Operating Conditions*.

³ Digital IO pins are those powered by VDD3P3_CPU, and RTC IO pins are those powered by VDD3P3_RTC and so on, as shown in Figure 2-3 *ESP32-C3 Power Scheme*. See also Table 2-1 *Pin Overview* > Column *Pin Providing Power*.

⁴ To configure VDD_SPI as input or output, see *ESP32-C3 Technical Reference Manual* > Chapter *Low-power Management*.

2.5.2 Power Scheme

The power scheme is shown in Figure 2-3 *ESP32-C3 Power Scheme*.

The components on the chip are powered via voltage regulators.

Table 2-7. Voltage Regulators

Voltage Regulator	Output	Power Supply
Digital	1.1 V	Digital power domain
Low-power	1.1 V	RTC power domain

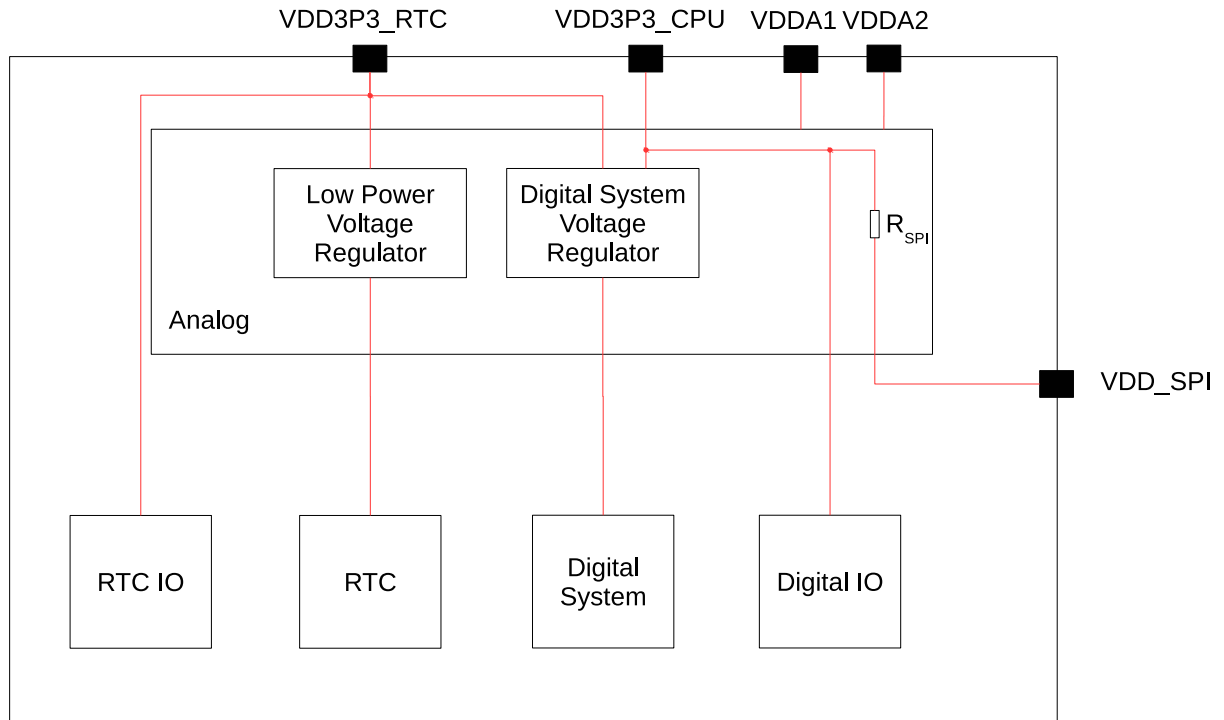

Figure 2-3. ESP32-C3 Power Scheme

2.5.3 Chip Power-up and Reset

Once the power is supplied to the chip, its power rails need a short time to stabilize. After that, `CHIP_EN` – the pin used for power-up and reset – is pulled high to activate the chip. For information on `CHIP_EN` as well as power-up and reset timing, see Figure 2-4 and Table 2-8.

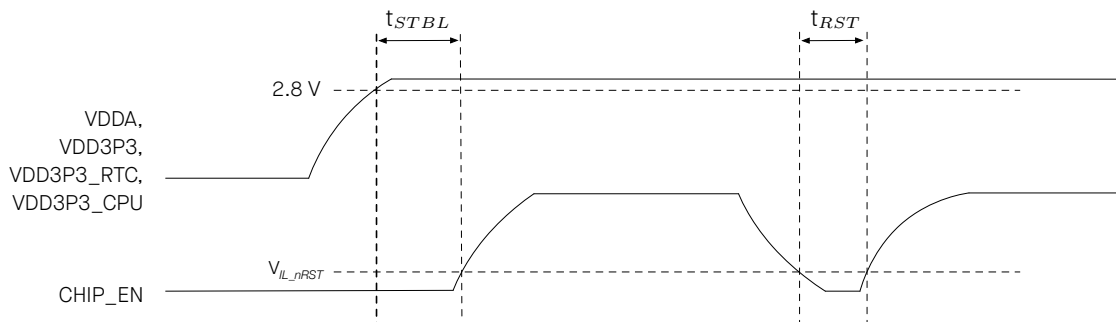

Figure 2-4. Visualization of Timing Parameters for Power-up and Reset

Table 2-8. Description of Timing Parameters for Power-up and Reset

Parameter	Description	Min (μs)
t_{STBL}	Time reserved for the power rails of VDDA, VDD3P3, VDD3P3_RTC, and VDD3P3_CPU to stabilize before the CHIP_EN pin is pulled high to activate the chip	50
t_{RST}	Time reserved for CHIP_EN to stay below V_{IL_nRST} to reset the chip (see Table 4-4)	50

2.6 Strapping Pins

At each startup or reset, a chip requires some initial configuration parameters, such as in which boot mode to load the chip, etc. These parameters are passed over via the strapping pins. After reset, the strapping pins operate as regular IO pins.

The parameters controlled by the given strapping pins at chip reset are as follows:

- **Chip boot mode** – GPIO2, GPIO8, and GPIO9
- **ROM messages printing** – GPIO8

GPIO9 connected to the chip's internal weak pull-up resistor at chip reset. This resistor determines the default bit value of GPIO9. Also, this resistor determines the bit value if GPIO9 is connected to an external high-impedance circuit.

Table 2-9. Default Configuration of Strapping Pins

Strapping Pin	Default Configuration	Bit Value
GPIO2	Floating	–
GPIO8	Floating	–
GPIO9	Pull-up	1

To change the bit values, the strapping pins should be connected to external pull-down/pull-up resistances. If the ESP32-C3 is used as a device by a host MCU, the strapping pin voltage levels can also be controlled by the host MCU.

All strapping pins have latches. At system reset, the latches sample the bit values of their respective strapping pins and store them until the chip is powered down or shut down. The states of latches cannot be changed in any other way. It makes the strapping pin values available during the entire chip operation, and the pins are freed up to be used as regular IO pins after reset.

Regarding the timing requirements for the strapping pins, there are such parameters as *setup time* and *hold time*. For more information, see Table 2-10 and Figure 2-5.

Table 2-10. Description of Timing Parameters for the Strapping Pins

Parameter	Description	Min (ms)
t_{SU}	<i>Setup time</i> is the time reserved for the power rails to stabilize before the CHIP_EN pin is pulled high to activate the chip.	0
t_H	<i>Hold time</i> is the time reserved for the chip to read the strapping pin values after CHIP_EN is already high and before these pins start operating as regular IO pins.	3

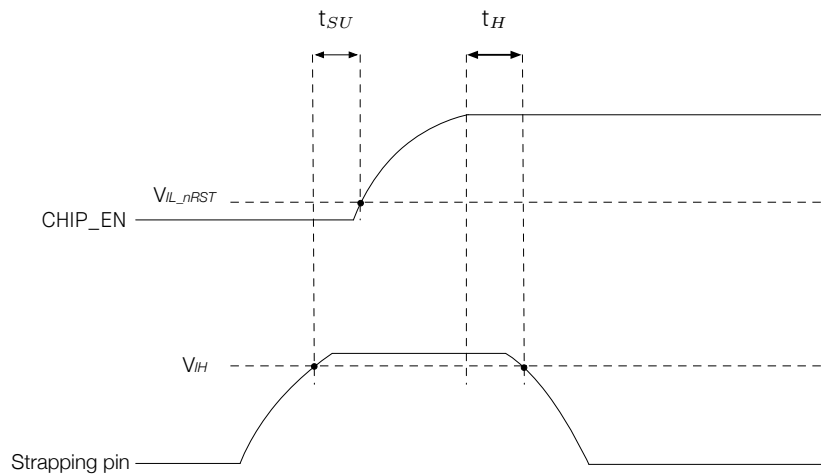

Figure 2-5. Visualization of Timing Parameters for the Strapping Pins

2.6.1 Chip Boot Mode Control

GPIO2, GPIO8, and GPIO9 control the boot mode after the reset is released. See Table 2-11 [Chip Boot Mode Control](#).

Table 2-11. Chip Boot Mode Control

Boot Mode	GPIO2 ^a	GPIO8	GPIO9
Default configuration	– (Floating)	– (Floating)	1 (Pull-up)
SPI Boot (default)	1	Any value	1
Joint Download Boot ^b	1	1	0

^a GPIO2 actually does not determine SPI Boot and Joint Download Boot mode, but it is recommended to pull this pin up due to glitches.

^b Joint Download Boot mode supports the following download methods:

- USB-Serial-JTAG Download Boot
- UART Download Boot

In SPI Boot mode, the ROM bootloader loads and executes the program from SPI flash to boot the system.

In Joint Download Boot mode, users can download binary files into flash using UART0 or USB interface. It is also possible to download binary files into SRAM and execute it from SRAM.

2.6.2 ROM Messages Printing Control

During boot process the messages by the ROM code can be printed to:

- **USB Serial/JTAG controller.** For this, set EFUSE_USB_PRINT_CHANNEL and EFUSE_DIS_USB_SERIAL_JTAG to 0.
- **UART.** For this, set EFUSE_DIS_USB_SERIAL_JTAG to 1. In this case, EFUSE_UART_PRINT_CONTROL and GPIO8 control ROM messages printing as shown in Table 2-12 [ROM Messages Printing Control](#).

Table 2-12. ROM Messages Printing Control

eFuse ¹	GPIO8	ROM Messages Printing
0	Ignored	Always enabled
1	0	Enabled
	1	Disabled
2	0	Disabled
	1	Enabled
3	Ignored	Always disabled

¹ eFuse: EFUSE_UART_PRINT_CONTROL

2.7 Pin Mapping Between Chip and Flash

Table 2-13 lists the pin mapping between the chip and flash for all SPI modes.

For chip variants with in-package flash (see Table 1-1 Comparison), the pins allocated for communication with in-package flash can be identified depending on the SPI mode used.

For off-package flash, these are the recommended pin mappings.

For more information on SPI controllers, see also Section 3.4.2 Serial Peripheral Interface (SPI).

Notice:

It is not recommended to use the pins connected to flash for any other purposes.

Table 2-13. Pin Mapping Between Chip and In-package Flash

Pin No.	Pin Name	Single SPI Flash	Dual SPI Flash	Quad SPI / QPI Flash
22	SPICLK	CLK	CLK	CLK
21	SPICSO ¹	CS#	CS#	CS#
23	SPIID	DI	DI	DI
24	SPIQ	DO	DO	DO
20	SPIWP	WP#	WP#	WP#
19	SPIHD	HOLD#	HOLD#	HOLD#

¹ CS0 is for in-package flash

3 Functional Description

This chapter describes the functions of ESP32-C3.

3.1 CPU and Memory

3.1.1 CPU

ESP32-C3 has a low-power 32-bit RISC-V single-core microprocessor with the following features:

- four-stage pipeline that supports a clock frequency of up to 160 MHz
- RV32IMC ISA
- 32-bit multiplier and 32-bit divider
- up to 32 vectored interrupts at seven priority levels
- up to 8 hardware breakpoints/watchpoints
- up to 16 PMP regions
- JTAG for debugging

For more information, please refer to Chapter [ESP-RISC-V CPU](#) in *ESP32-C3 Technical Reference Manual*.

3.1.2 Internal Memory

ESP32-C3's internal memory includes:

- **384 KB of ROM:** for booting and core functions.
- **400 KB of on-chip SRAM:** for data and instructions, running at a configurable frequency of up to 160 MHz. Of the 400 KB SRAM, 16 KB is configured for cache.
- **RTC FAST memory:** 8 KB of SRAM that can be accessed by the main CPU. It can retain data in Deep-sleep mode.
- **4 Kbit of eFuse:** 1792 bits are reserved for your data, such as encryption key and device ID.
- **In-package flash :** See details in Chapter [1 ESP32-C3 Series Comparison](#).

For more information, please refer to Chapter [System and Memory](#) in *ESP32-C3 Technical Reference Manual*.

3.1.3 Off-package Flash

ESP32-C3 supports SPI, Dual SPI, Quad SPI, and QPI interfaces that allow connection to multiple off-package flash, i.e. flash outside the chip's package.

CPU's instruction memory space and read-only data memory space can map into the off-package flash of ESP32-C3, whose size can be 16 MB at most. ESP32-C3 supports hardware encryption/decryption based on XTS-AES to protect developers' programs and data in flash.

Through high-speed caches, ESP32-C3 can support at a time up to:

- 8 MB of instruction memory space which can map into flash as individual blocks of 64 KB. 8-bit, 16-bit and 32-bit reads are supported.
- 8 MB of data memory space which can map into flash as individual blocks of 64 KB. 8-bit, 16-bit and 32-bit reads are supported.

Note:

After ESP32-C3 is initialized, software can customize the mapping of off-package flash into the CPU address space.

For more information, please refer to Chapter [System and Memory](#) in *ESP32-C3 Technical Reference Manual*.

3.1.4 Address Mapping Structure

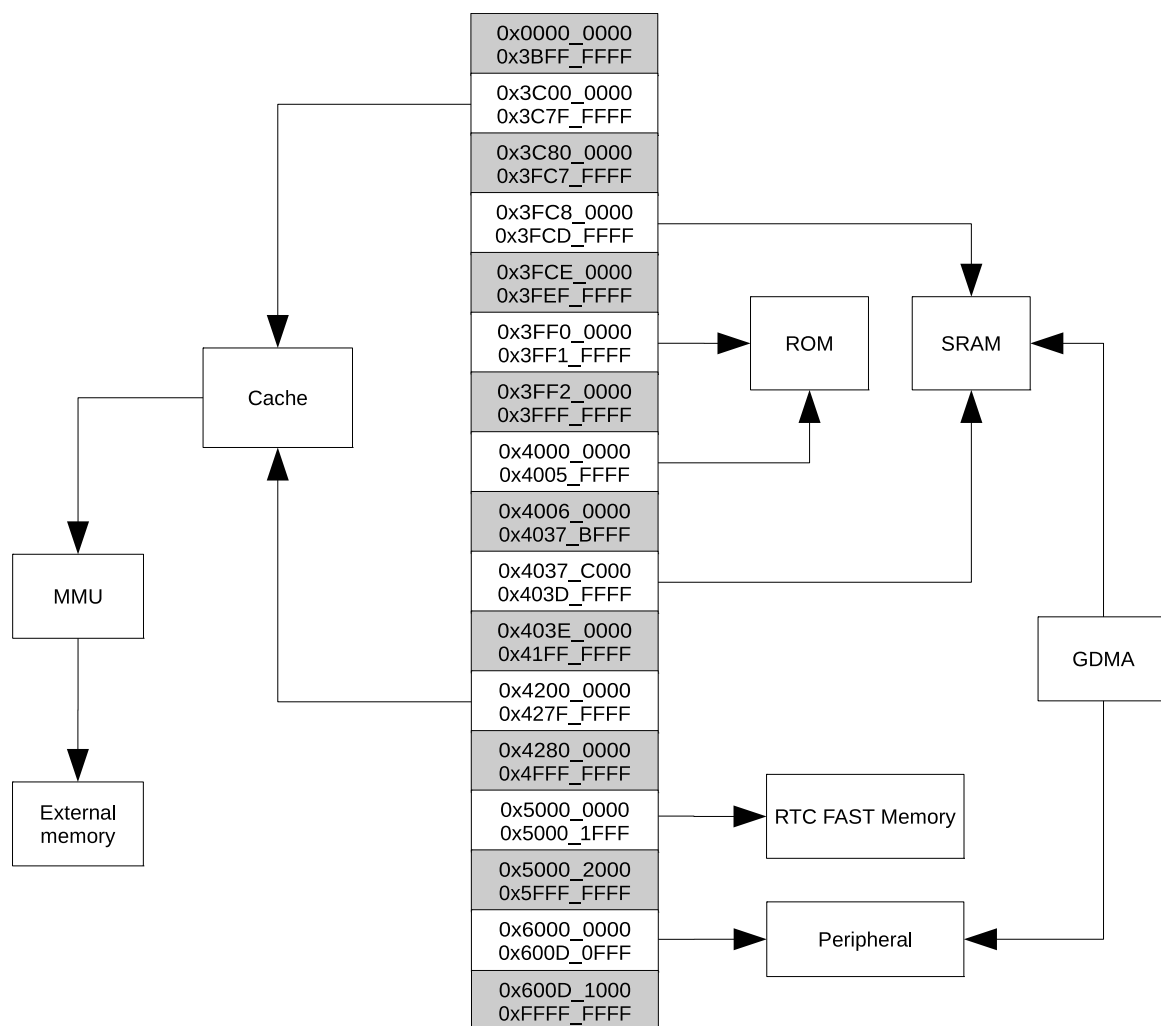

Figure 3-1. Address Mapping Structure

Note:

The memory space with gray background is not available for use.

3.1.5 Cache

ESP32-C3 has an eight-way set associative cache. This cache is read-only and has the following features:

- size: 16 KB
- block size: 32 bytes
- pre-load function
- lock function
- critical word first and early restart

3.2 System Clocks

For more information, please refer to Chapter [Reset and Clock](#) in *ESP32-C3 Technical Reference Manual*.

3.2.1 CPU Clock

The CPU clock has three possible sources:

- external main crystal clock
- fast RC oscillator (typically about 17.5 MHz, and adjustable)
- PLL clock

The application can select the clock source from the three clocks above. The selected clock source drives the CPU clock directly, or after division, depending on the application. Once the CPU is reset, the default clock source would be the external main crystal clock divided by 2.

Note:

ESP32-C3 is unable to operate without an external main crystal clock.

3.2.2 RTC Clock

The RTC slow clock is used for RTC counter, RTC watchdog and low-power controller. It has three possible sources:

- external low-speed (32 kHz) crystal clock
- internal slow RC oscillator (typically about 136 kHz, and adjustable)
- internal fast RC oscillator divided clock (derived from the fast RC oscillator divided by 256)

The RTC fast clock is used for RTC peripherals and sensor controllers. It has two possible sources:

- external main crystal clock divided by 2
- internal fast RC oscillator divide-by-N clock (typically about 17.5 MHz, and adjustable)

3.3 Analog Peripherals

For more information, please refer to Chapter [On-Chip Sensors and Analog Signal Processing](#) in *ESP32-C3 Technical Reference Manual*.

3.3.1 Analog-to-Digital Converter (ADC)

ESP32-C3 integrates two 12-bit SAR ADCs.

- ADC1 supports measurements on 5 channels, and is factory-calibrated.
- ADC2 supports measurements on 1 channel, and is not factory-calibrated.

Note:

ADC2 of some chip revisions is not operable. For details, please refer to [ESP32-C3 Series SoC Errata](#).

For ADC characteristics, please refer to Table 4.5.

For GPIOs assigned to ADC, please refer to Table 3-2.

3.3.2 Temperature Sensor

The temperature sensor generates a voltage that varies with temperature. The voltage is internally converted via an ADC into a digital value.

The temperature sensor has a range of $-40\text{ }^{\circ}\text{C}$ to $125\text{ }^{\circ}\text{C}$. It is designed primarily to sense the temperature changes inside the chip. The temperature value depends on factors like microcontroller clock frequency or I/O load. Generally, the chip's internal temperature is higher than the operating ambient temperature.

3.4 Digital Peripherals

3.4.1 General Purpose Input / Output Interface (GPIO)

ESP32-C3 has 22 or 16 GPIO pins which can be assigned various functions by configuring corresponding registers. Besides digital signals, some GPIOs can be also used for analog functions, such as ADC.

All GPIOs have selectable internal pull-up or pull-down, or can be set to high impedance. When these GPIOs are configured as an input, the input value can be read by software through the register. Input GPIOs can also be set to generate edge-triggered or level-triggered CPU interrupts. All digital IO pins are bi-directional, non-inverting and tristate, including input and output buffers with tristate control. These pins can be multiplexed with other functions, such as the UART, SPI, etc. For low-power operations, the GPIOs can be set to holding state.

The IO MUX and the GPIO matrix are used to route signals from peripherals to GPIO pins. Together they provide highly configurable I/O. Using GPIO Matrix, peripheral input signals can be configured from any IO pins while peripheral output signals can be configured to any IO pins.

For more information, please refer to Chapter [IO MUX and GPIO Matrix \(GPIO, IO_MUX\)](#) in *ESP32-C3 Technical Reference Manual*.

3.4.2 Serial Peripheral Interface (SPI)

ESP32-C3 has the following SPI interfaces:

- **SPI0** used by ESP32-C3's GDMA controller and cache to access in-package or off-package flash
- **SPI1** used by the CPU to access in-package or off-package flash
- **SPI2** is a general purpose SPI controller with access to a DMA channel allocated by the GDMA controller

Features of SPI0 and SPI1

- Supports Single SPI, Dual SPI, and Quad SPI, QPI modes
- Configurable clock frequency with a maximum of 120 MHz in Single Transfer Rate (STR) mode
- Data transmission is in bytes

Features of SPI2

- Supports operation as a master or slave
- Connects to a DMA channel allocated by the GDMA controller
- Supports Single SPI, Dual SPI, and Quad SPI, QPI
- Configurable clock polarity (CPOL) and phase (CPHA)
- Configurable clock frequency
- Data transmission is in bytes
- Configurable read and write data bit order: most-significant bit (MSB) first, or least-significant bit (LSB) first
- As a master
 - Supports 2-line full-duplex communication with clock frequency up to 80 MHz
 - Supports 1-, 2-, 4-line half-duplex communication with clock frequency up to 80 MHz
 - Provides six SPI_CS pins for connection with six independent SPI slaves
 - Configurable CS setup time and hold time
- As a slave
 - Supports 2-line full-duplex communication with clock frequency up to 60 MHz
 - Supports 1-, 2-, 4-line half-duplex communication with clock frequency up to 60 MHz

For GPIOs assigned to SPI, please refer to Table 3-2.

For more information, please refer to Chapter [SPI Controller \(SPI\)](#) in *ESP32-C3 Technical Reference Manual*.

3.4.3 Universal Asynchronous Receiver Transmitter (UART)

ESP32-C3 has two UART interfaces, i.e. UART0 and UART1, which support IrDA and asynchronous communication (RS232 and RS485) at a speed of up to 5 Mbps. The UART controller provides hardware flow

control (CTS and RTS signals) and software flow control (XON and XOFF). Both UART interfaces connect to GDMA via UHCIO, and can be accessed by the GDMA controller or directly by the CPU.

For GPIOs assigned to UART, please refer to Table 3-2.

For more information, please refer to Chapter [UART Controller \(UART\)](#) in *ESP32-C3 Technical Reference Manual*.

3.4.4 I2C Interface

ESP32-C3 has an I2C bus interface which is used for I2C master mode or slave mode, depending on your configuration. The I2C interface supports:

- standard mode (100 Kbit/s)
- fast mode (400 Kbit/s)
- up to 800 Kbit/s (constrained by SCL and SDA pull-up strength)
- 7-bit and 10-bit addressing mode
- double addressing mode
- 7-bit broadcast address

You can configure instruction registers to control the I2C interface for more flexibility.

For GPIOs assigned to I2C, please refer to Table 3-2.

For more information, please refer to Chapter [I2C Controller \(I2C\)](#) in *ESP32-C3 Technical Reference Manual*.

3.4.5 I2S Interface

ESP32-C3 includes a standard I2S interface. This interface can operate as a master or a slave in full-duplex mode or half-duplex mode, and can be configured for 8-bit, 16-bit, 24-bit, or 32-bit serial communication. BCK clock frequency, from 10 kHz up to 40 MHz, is supported.

The I2S interface connects to the GDMA controller. The interface supports TDM PCM, TDM MSB alignment, TDM standard, and PDM standard.

For GPIOs assigned to I2S, please refer to Table 3-2.

For more information, please refer to Chapter [I2S Controller \(I2S\)](#) in *ESP32-C3 Technical Reference Manual*.

3.4.6 Remote Control Peripheral

The Remote Control Peripheral (RMT) supports two channels of infrared remote transmission and two channels of infrared remote reception. By controlling pulse waveform through software, it supports various infrared and other single wire protocols. All four channels share a 192 × 32-bit memory block to store transmit or receive waveform.

For GPIOs assigned to the Remote Control Peripheral, please refer to Table 3-2.

For more information, please refer to Chapter [Remote Control Peripheral \(RMT\)](#) in *ESP32-C3 Technical Reference Manual*.

3.4.7 LED PWM Controller

The LED PWM controller can generate independent digital waveform on six channels. The LED PWM controller:

- can generate digital waveform with configurable periods and duty cycle. The resolution of duty cycle can be up to 14 bits.
- has multiple clock sources, including APB clock and external main crystal clock.
- can operate when the CPU is in Light-sleep mode.
- supports gradual increase or decrease of duty cycle, which is useful for the LED RGB color-gradient generator.

For GPIOs assigned to LED PWM, please refer to Table 3-2.

For more information, please refer to Chapter [LED PWM Controller \(LEDC\)](#) in *ESP32-C3 Technical Reference Manual*.

3.4.8 General DMA Controller

ESP32-C3 has a general DMA controller (GDMA) with six independent channels, i.e. three transmit channels and three receive channels. These six channels are shared by peripherals with DMA feature. The GDMA controller implements a fixed-priority scheme among these channels, whose priority can be configured.

The GDMA controller controls data transfer using linked lists. It allows peripheral-to-memory and memory-to-memory data transfer at a high speed. All channels can access internal RAM.

Peripherals on ESP32-C3 with DMA feature are SPI2, UHCI0, I2S, AES, SHA, and ADC.

For more information, please refer to Chapter [GDMA Controller \(GDMA\)](#) in *ESP32-C3 Technical Reference Manual*.

3.4.9 USB Serial/JTAG Controller

ESP32-C3 integrates a USB Serial/JTAG controller. This controller has the following features:

- CDC-ACM virtual serial port and JTAG adapter functionality
- USB 2.0 full speed compliant, capable of up to 12 Mbit/s transfer speed (Note that this controller does not support the faster 480 Mbit/s high-speed transfer mode)
- programming in-package/off-package flash
- CPU debugging with compact JTAG instructions
- a full-speed USB PHY integrated in the chip

For GPIOs assigned to USB Serial/JTAG, please refer to Table 3-2.

For more information, please refer to Chapter [USB Serial/JTAG Controller \(USB_SERIAL_JTAG\)](#) in *ESP32-C3 Technical Reference Manual*.

3.4.10 TWAI® Controller

ESP32-C3 has a TWAI® controller with the following features:

- compatible with ISO 11898-1 protocol (CAN Specification 2.0)
- standard frame format (11-bit ID) and extended frame format (29-bit ID)
- bit rates from 1 Kbit/s to 1 Mbit/s
- multiple modes of operation: Normal, Listen Only, and Self-Test (no acknowledgment required)
- 64-byte receive FIFO
- acceptance filter (single and dual filter modes)
- error detection and handling: error counters, configurable error interrupt threshold, error code capture, arbitration lost capture

For GPIOs assigned to TWAI, please refer to Table 3-2.

For more information, please refer to Chapter [Two-wire Automotive Interface \(TWAI\)](#) in *ESP32-C3 Technical Reference Manual*.

3.5 Radio and Wi-Fi

ESP32-C3 radio consists of the following blocks:

- 2.4 GHz receiver
- 2.4 GHz transmitter
- bias and regulators
- balun and transmit-receive switch
- clock generator

3.5.1 2.4 GHz Receiver

The 2.4 GHz receiver demodulates the 2.4 GHz RF signal to quadrature baseband signals and converts them to the digital domain with two high-resolution, high-speed ADCs. To adapt to varying signal channel conditions, ESP32-C3 integrates RF filters, Automatic Gain Control (AGC), DC offset cancelation circuits, and baseband filters.

3.5.2 2.4 GHz Transmitter

The 2.4 GHz transmitter modulates the quadrature baseband signals to the 2.4 GHz RF signal, and drives the antenna with a high-powered CMOS power amplifier. The use of digital calibration further improves the linearity of the power amplifier.

Additional calibrations are integrated to cancel any radio imperfections, such as:

- carrier leakage
- I/Q amplitude/phase matching
- baseband nonlinearities
- RF nonlinearities
- antenna matching

These built-in calibration routines reduce the cost, time, and specialized equipment required for product testing.

3.5.3 Clock Generator

The clock generator produces quadrature clock signals of 2.4 GHz for both the receiver and the transmitter. All components of the clock generator are integrated into the chip, including inductors, varactors, filters, regulators and dividers.

The clock generator has built-in calibration and self-test circuits. Quadrature clock phases and phase noise are optimized on chip with patented calibration algorithms which ensure the best performance of the receiver and the transmitter.

3.5.4 Wi-Fi Radio and Baseband

ESP32-C3 Wi-Fi radio and baseband support the following features:

- 802.11b/g/n
- 802.11n MCS0-7 that supports 20 MHz and 40 MHz bandwidth
- 802.11n MCS32
- 802.11n 0.4 μ s guard interval
- data rate up to 150 Mbps
- RX STBC (single spatial stream)
- adjustable transmitting power
- antenna diversity

ESP32-C3 supports antenna diversity with an external RF switch. This switch is controlled by one or more GPIOs, and used to select the best antenna to minimize the effects of channel imperfections.

3.5.5 Wi-Fi MAC

ESP32-C3 implements the full 802.11 b/g/n Wi-Fi MAC protocol. It supports the Basic Service Set (BSS) STA and SoftAP operations under the Distributed Control Function (DCF). Power management is handled automatically with minimal host interaction to minimize the active duty period.

ESP32-C3 Wi-Fi MAC applies the following low-level protocol functions automatically:

- 4 \times virtual Wi-Fi interfaces
- infrastructure BSS in Station mode, SoftAP mode, Station + SoftAP mode, and promiscuous mode
- RTS protection, CTS protection, Immediate Block ACK
- fragmentation and defragmentation
- TX/RX A-MPDU, TX/RX A-MSDU
- transmit opportunity (TXOP)
- Wi-Fi multimedia (WMM)
- GCMP, CCMP, TKIP, WAPI, WEP, BIP, WPA2-PSK/WPA2-Enterprise, and WPA3-PSK/WPA3-Enterprise

- automatic beacon monitoring (hardware TSF)
- 802.11mc FTM

3.5.6 Networking Features

Espressif provides libraries for TCP/IP networking, ESP-WIFI-MESH networking, and other networking protocols over Wi-Fi. TLS 1.0, 1.1 and 1.2 is also supported.

3.6 Bluetooth LE

ESP32-C3 includes a Bluetooth Low Energy subsystem that integrates a hardware link layer controller, an RF/modem block and a feature-rich software protocol stack. It supports the core features of Bluetooth 5 and Bluetooth mesh.

3.6.1 Bluetooth LE Radio and PHY

Bluetooth Low Energy radio and PHY in ESP32-C3 support:

- 1 Mbps PHY
- 2 Mbps PHY for higher data rates
- coded PHY for longer range (125 Kbps and 500 Kbps)
- HW Listen before talk (LBT)

3.6.2 Bluetooth LE Link Layer Controller

Bluetooth Low Energy Link Layer Controller in ESP32-C3 supports:

- LE advertising extensions, to enhance broadcasting capacity and broadcast more intelligent data
- multiple advertisement sets
- simultaneous advertising and scanning
- multiple connections in simultaneous central and peripheral roles
- adaptive frequency hopping and channel assessment
- LE channel selection algorithm #2
- connection parameter update
- high duty cycle non-connectable advertising
- LE privacy 1.2
- LE data packet length extension
- link layer extended scanner filter policies
- low duty cycle directed advertising
- link layer encryption
- LE Ping

3.7 Power Management

The ESP32-C3 has an advanced Power Management Unit (PMU). It can be flexibly configured to power up different power domains of the chip to achieve the best balance between chip performance, power consumption, and wakeup latency.

Configuring the PMU is a complex procedure. To simplify power management for typical scenarios, there are the following **predefined power modes** that power up different combinations of power domains:

- **Active mode** – The CPU, RF circuits, and all peripherals are on. The chip can process data, receive, transmit, and listen.
- **Modem-sleep mode** – The CPU is on, but the clock frequency can be reduced. The wireless connections can be configured to remain active as RF circuits are periodically switched on when required.
- **Light-sleep mode** – The CPU stops running, and can be optionally powered on. The chip can be woken up via all wake up mechanisms: MAC, RTC timer, or external interrupts. Wireless connections can remain active. Some groups of digital peripherals can be optionally shut down.
- **Deep-sleep mode** – Only RTC is powered on. Wireless connection data is stored in RTC memory.

For power consumption in different power modes, see Section [4.6 Current Consumption](#).

Figure [3-2 Components and Power Domains](#) and the following Table [3-1](#) show the distribution of chip components between **power domains** and **power subdomains**.

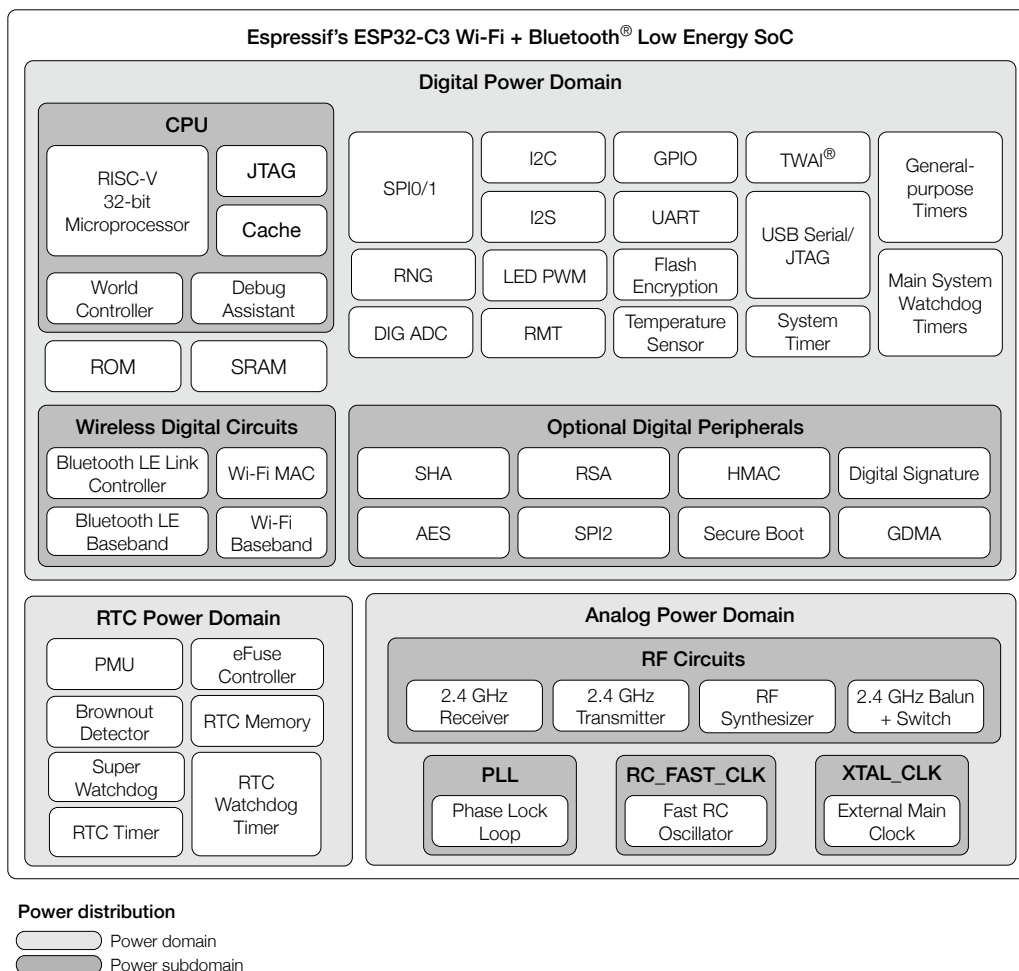

Figure 3-2. Components and Power Domains

Table 3-1. Components and Power Domains

Power Mode \ Power Domain	RTC	Digital				Analog				
		CPU	Optional Digital Periph	Wireless Digital Circuits	FOSC_CLK	XTAL_CLK	PLL	RF Circuits		
Active	ON	ON	ON	ON	ON	ON	ON	ON	ON	ON
Modem-sleep	ON	ON	ON	ON	ON ¹	ON	ON	ON	ON	OFF ²
Light-sleep	ON	ON	OFF ¹	ON ¹	OFF ¹	ON	OFF	OFF	OFF	OFF ²
Deep-sleep	ON	OFF	OFF	OFF	OFF	ON	OFF	OFF	OFF	OFF

¹ Configurable, see the TRM.

² If Wireless Digital Circuits are on, RF circuits are periodically switched on when required by internal operation to keep active wireless connections running.

For more information, please refer to Chapter [Low-Power Management \(RTC_CNTL\)](#) in *ESP32-C3 Technical Reference Manual*.

3.8 Timers

3.8.1 General Purpose Timers

ESP32-C3 has two 54-bit general-purpose timers, which are based on 16-bit prescalers and 54-bit auto-reload-capable up/down-timers.

The timers' features are summarized as follows:

- a 16-bit clock prescaler, from 1 to 65536
- a 54-bit time-base counter programmable to be incrementing or decrementing
- able to read real-time value of the time-base counter
- halting and resuming the time-base counter
- programmable alarm generation
- level interrupt generation

For more information, please refer to Chapter [Timer Group \(TIMG\)](#) in *ESP32-C3 Technical Reference Manual*.

3.8.2 System Timer

ESP32-C3 integrates a 52-bit system timer, which has two 52-bit counters and three comparators. The system timer has the following features:

- counters with a fixed clock frequency of 16 MHz
- three types of independent interrupts generated according to alarm value
- two alarm modes: target mode and period mode
- 52-bit target alarm value and 26-bit periodic alarm value
- automatic reload of counter value
- counters can be stalled if the CPU is stalled or in OCD mode

For more information, please refer to Chapter [System Timer \(SYSTIMER\)](#) in *ESP32-C3 Technical Reference Manual*.

3.8.3 Watchdog Timers

For more information, please refer to Chapter [Watchdog Timers \(WDT\)](#) in *ESP32-C3 Technical Reference Manual*.

Digital Watchdog Timers

ESP32-C3 contains three digital watchdog timers: one in each of the two timer groups (called Main System Watchdog Timers, or MWDT) and one in the RTC module (called the RTC Watchdog Timer, or RWDT).

During the flash boot process, RWDT and the MWDT in timer group 0 (TIMG0) are enabled automatically in order to detect and recover from booting errors.

Digital watchdog timers have the following features:

- four stages, each with a programmable timeout value. Each stage can be configured, enabled and disabled separately

- interrupt, CPU reset, or core reset for MWDT upon expiry of each stage; interrupt, CPU reset, core reset, or system reset for RWDT upon expiry of each stage
- 32-bit expiry counter
- write protection, to prevent RWDT and MWDT configuration from being altered inadvertently
- flash boot protection
If the boot process from an SPI flash does not complete within a predetermined period of time, the watchdog will reboot the entire main system.

Analog Watchdog Timer

ESP32-C3 also has one analog watchdog timer: RTC super watchdog timer (SWD). It is an ultra-low-power circuit in analog domain that helps to prevent the system from operating in a sub-optimal state and resets the system if required.

SWD has the following features:

- Ultra-low power
- Interrupt to indicate that the SWD timeout period is close to expiring
- Various dedicated methods for software to feed SWD, which enables SWD to monitor the working state of the whole operating system

3.9 Cryptographic Hardware Accelerators

ESP32-C3 is equipped with hardware accelerators of general algorithms, such as AES-128/AES-256 (FIPS PUB 197), ECB/CBC/OFB/CFB/CTR (NIST SP 800-38A), SHA1/SHA224/SHA256 (FIPS PUB 180-4), and RSA3072. The chip also supports independent arithmetic, such as large-number modular multiplication and large-number multiplication. The maximum operation length for RSA and large-number modular multiplication is 3072 bits. The maximum operand length for large-number multiplication is 1536 bits.

3.10 Physical Security Features

- Transparent off-package flash encryption (AES-XTS algorithm) with software inaccessible key prevents unauthorized readout of your application code or data.
- Secure boot feature uses a hardware root of trust to ensure only signed firmware (with RSA-PSS signature) can be booted.
- HMAC module can use a software inaccessible MAC key to generate MAC signatures for identity verification and other purposes.
- Digital Signature module can use a software inaccessible secure key to generate RSA signatures for identity verification.
- World Controller provides two running environments for software. All hardware and software resources are sorted to two groups, and placed in either secure or general world. The secure world cannot be accessed by hardware in the general world, thus establishing a security boundary.

3.11 Peripheral Pin Configurations

Table 3-2. Peripheral Pin Configurations

Interface	Signal	Pin	Function
ADC	ADC1_CH0	XTAL_32K_P	Two 12-bit SAR ADCs
	ADC1_CH1	XTAL_32K_N	
	ADC1_CH2	GPIO2	
	ADC1_CH3	GPIO3	
	ADC1_CH4	MTMS	
	ADC2_CH0	MTDI	
JTAG	MTDI	MTDI	JTAG for software debugging
	MTCK	MTCK	
	MTMS	MTMS	
	MTDO	MTDO	
UART	UORXD_in	Any GPIO pins	Two UART channels with hardware flow control and GDMA
	UOCTS_in		
	UODSR_in		
	UOTXD_out		
	UORTS_out		
	UODTR_out		
	U1RXD_in		
	U1CTS_in		
	U1DSR_in		
	U1TXD_out		
	U1RTS_out		
	U1DTR_out		
	I2C		
I2CEXT0_SDA_in			
I2CEXT0_SCL_out			
I2CEXT0_SDA_out			
LED PWM	ledc_ls_sig_out0~5	Any GPIO pins	Six independent PWM channels
I2S	I2SOO_BCK_in	Any GPIO pins	Stereo input and output from/to the audiocodec
	I2S_MCLK_in		
	I2SO_WS_in		
	I2SI_SD_in		
	I2SI_BCK_in		
	I2SI_WS_in		
	I2SO_BCK_out		
	I2S_MCLK_out		
	I2SO_WS_out		
	I2SO_SD_out		
	I2SI_BCK_out		
	I2SI_WS_out		
	I2SO_SD1_out		

Interface	Signal	Pin	Function
Remote Control Peripheral	RMT_SIG_IN0~1	Any GPIO pins	Two channels for an IR transceiver of various waveforms
	RMT_SIG_OUT0~1		
SPI0/1	SPICLK_out_mux	SPICLK	Support Standard SPI, Dual SPI, Quad SPI, and QPI that allow connection to off-package flash
	SPICSO_out	SPICSO	
	SPICS1_out	Any GPIO pins	
	SPID_in/_out	SPID	
	SPIQ_in/_out	SPIQ	
	SPIWP_in/_out	SPIWP	
	SPIHD_in/_out	SPIHD	
SPI2	FSPICLK_in/_out_mux	Any GPIO pins	<ul style="list-style-type: none"> • Master mode and slave mode of SPI, Dual SPI, Quad SPI, and QPI • Connection to off-package flash, RAM, and other SPI devices • Four modes of SPI transfer format • Configurable SPI frequency • 64-byte FIFO or GDMA buffer
	FSPICSO_in/_out		
	FSPICS1~5_out		
	FSPID_in/_out		
	FSPIQ_in/_out		
	FSPIWP_in/_out		
	FSPIHD_in/_out		
USB Serial/JTAG	USB_D+	GPIO19	USB-to-serial converter, and USB-to-JTAG converter
	USB_D-	GPIO18	
TWAI	twai_rx	Any GPIO pins	Compatible with ISO 11898-1 protocol
	twai_tx		
	twai_bus_off_on		
	twai_clkout		

4 Electrical Characteristics

4.1 Absolute Maximum Ratings

Stresses above those listed in Table 4-1 *Absolute Maximum Ratings* may cause permanent damage to the device. These are stress ratings only and normal operation of the device at these or any other conditions beyond those indicated in Section 4.2 *Recommended Operating Conditions* is not implied. Exposure to absolute-maximum-rated conditions for extended periods may affect device reliability.

Table 4-1. Absolute Maximum Ratings

Parameter	Description	Min	Max	Unit
Input power pins ¹	Allowed input voltage	-0.3	3.6	V
I_{output} ²	Cumulative IO output current	—	1000	mA
T_{STORE}	Storage temperature	-40	150	°C

¹ For more information on input power pins, see Section 2.5 *Power Supply*.

² The product proved to be fully functional after all its IO pins were pulled high while being connected to ground for 24 consecutive hours at ambient temperature of 25 °C.

4.2 Recommended Operating Conditions

For recommended ambient temperature, see Section 1 *ESP32-C3 Series Comparison*.

Table 4-2. Recommended Operating Conditions

Parameter ¹	Description	Min	Typ	Max	Unit
VDDA, VDD3P3, VDD3P3_RTC	Recommended input voltage	3.0	3.3	3.6	V
VDD3P3_CPU ^{2,3}	Recommended input voltage	3.0	3.3	3.6	V
VDD_SPI (as input)	—	3.0	3.3	3.6	V
I_{VDD}	Cumulative input current	0.5	—	—	A

¹ See in conjunction with Section 2.5 *Power Supply*.

² If writing to eFuses, the voltage on VDD3P3_CPU should not exceed 3.3 V as the circuits responsible for burning eFuses are sensitive to higher voltages.

³ If VDD3P3_CPU is used to power VDD_SPI (see Section 2.5.2 *Power Scheme*), the voltage drop on R_{SPI} should be accounted for. See also Section 4.3 *VDD_SPI Output Characteristics*.

4.3 VDD_SPI Output Characteristics

Table 4-3. VDD_SPI Internal and Output Characteristics

Parameter	Description ¹	Typ	Unit
R_{SPI}	VDD_SPI powered by VDD3P3_CPU via R_{SPI} for 3.3 V flash_CPU ²	7.5	Ω

¹ See in conjunction with Section 2.5.2 Power Scheme.

² VDD3P3_CPU must be more than $VDD_{flash_min} + I_{flash_max} * R_{SPI}$;

where

- VDD_{flash_min} – minimum operating voltage of flash_CPU
- I_{flash_max} – maximum operating current of flash_CPU

4.4 DC Characteristics (3.3 V, 25 °C)

Table 4-4. DC Characteristics (3.3 V, 25 °C)

Parameter	Description	Min	Typ	Max	Unit
C_{IN}	Pin capacitance	—	2	—	pF
V_{IH}	High-level input voltage	$0.75 \times VDD^1$	—	$VDD^1 + 0.3$	V
V_{IL}	Low-level input voltage	-0.3	—	$0.25 \times VDD^1$	V
I_{IH}	High-level input current	—	—	50	nA
I_{IL}	Low-level input current	—	—	50	nA
V_{OH}^2	High-level output voltage	$0.8 \times VDD^1$	—	—	V
V_{OL}^2	Low-level output voltage	—	—	$0.1 \times VDD^1$	V
I_{OH}	High-level source current ($VDD^1 = 3.3$ V, $V_{OH} \geq 2.64$ V, PAD_DRIVER = 3)	—	40	—	mA
I_{OL}	Low-level sink current ($VDD^1 = 3.3$ V, $V_{OL} = 0.495$ V, PAD_DRIVER = 3)	—	28	—	mA
R_{PU}	Internal weak pull-up resistor	—	45	—	k Ω
R_{PD}	Internal weak pull-down resistor	—	45	—	k Ω
V_{IH_nRST}	Chip reset release voltage CHIP_EN voltage is within the specified range)	$0.75 \times VDD^1$	—	$VDD^1 + 0.3$	V
V_{IL_nRST}	Chip reset voltage (CHIP_EN voltage is within the specified range)	-0.3	—	$0.25 \times VDD^1$	V

¹ VDD – voltage from a power pin of a respective power domain.

² V_{OH} and V_{OL} are measured using high-impedance load.

4.5 ADC Characteristics

Table 4-5. ADC Characteristics

Symbol	Parameter	Min	Max	Unit
DNL (Differential nonlinearity) ¹	ADC connected to an external 100 nF capacitor; DC signal input; Ambient temperature at 25 °C; Wi-Fi off	-7	7	LSB
INL (Integral nonlinearity)		-12	12	LSB
Sampling rate	—	—	100	kSPS ²

¹ To get better DNL results, you can sample multiple times and apply a filter, or calculate the average value.

² kSPS means kilo samples-per-second.

The calibrated ADC results after hardware calibration and [software calibration](#) are shown in Table 4-6. For higher accuracy, you may implement your own calibration methods.

Table 4-6. ADC Calibration Results

Parameter	Description	Min	Max	Unit
Total error	ATTEN0, effective measurement range of 0 ~ 750	-10	10	mV
	ATTEN1, effective measurement range of 0 ~ 1050	-10	10	mV
	ATTEN2, effective measurement range of 0 ~ 1300	-10	10	mV
	ATTEN3, effective measurement range of 0 ~ 2500	-35	35	mV

4.6 Current Consumption

4.6.1 RF Current Consumption in Active Mode

The current consumption measurements are taken with a 3.3 V supply at 25 °C of ambient temperature at the RF port. All transmitters' measurements are based on a 100% duty cycle.

Table 4-7. Wi-Fi Current Consumption Depending on RF Modes

Work Mode ¹	Description	Peak (mA)	
Active (RF working)	TX	802.11b, 1 Mbps, @21 dBm	335
		802.11g, 54 Mbps, @19 dBm	285
		802.11n, HT20, MCS7, @18.5 dBm	276
		802.11n, HT40, MCS7, @18.5 dBm	278
	RX	802.11b/g/n, HT20	84
		802.11n, HT40	87

4.6.2 Current Consumption in Other Modes

Table 4-8. Current Consumption in Modem-sleep Mode

Mode	CPU Frequency (MHz)	Description	Typ	
			All Peripherals Clocks Disabled (mA)	All Peripherals Clocks Enabled (mA) ¹
Modem-sleep ^{2,3}	160	CPU is running	23	28
		CPU is idle	16	21
	80	CPU is running	17	22
		CPU is idle	13	18

¹ In practice, the current consumption might be different depending on which peripherals are enabled.

² In Modem-sleep mode, Wi-Fi is clock gated.

³ In Modem-sleep mode, the consumption might be higher when accessing flash. For a flash rated at 80 Mbit/s, in SPI 2-line mode the consumption is 10 mA.

Table 4-9. Current Consumption in Low-Power Modes

Mode	Description	Typ (μ A)
Light-sleep	VDD_SPI and Wi-Fi are powered down, and all GPIOs are high-impedance	130
Deep-sleep	RTC timer + RTC memory	5
Power off	CHIP_EN is set to low level, the chip is powered off	1

4.7 Reliability

Table 4-10. Reliability Qualifications

Test Item	Test Conditions	Test Standard
HTOL (High Temperature Operating Life)	125 °C, 1000 hours	JESD22-A108
ESD (Electro-Static Discharge Sensitivity)	HBM (Human Body Mode) ¹ \pm 2000 V	JS-001
	CDM (Charge Device Mode) ² \pm 1000 V	JS-002
Latch up	Current trigger \pm 200 mA	JESD78
	Voltage trigger $1.5 \times VDD_{max}$	
Preconditioning	Bake 24 hours @125 °C Moisture soak (level 3: 192 hours @30 °C, 60% RH) IR reflow solder: 260 + 0 °C, 20 seconds, three times	J-STD-020, JESD47, JESD22-A113
TCT (Temperature Cycling Test)	-65 °C / 150 °C, 500 cycles	JESD22-A104
uHAST (Highly Accelerated Stress Test, unbiased)	130 °C, 85% RH, 96 hours	JESD22-A118
HTSL (High Temperature Storage Life)	150 °C, 1000 hours	JESD22-A103

Cont'd on next page

Table 4-10 – cont'd from previous page

Test Item	Test Conditions	Test Standard
LTSL (Low Temperature Storage Life)	-40 °C, 1000 hours	JESD22-A119

¹ JEDEC document JEP155 states that 500 V HBM allows safe manufacturing with a standard ESD control process.

² JEDEC document JEP157 states that 250 V CDM allows safe manufacturing with a standard ESD control process.

4.8 Wi-Fi Radio

Table 4-11. Wi-Fi Frequency

Parameter	Min (MHz)	Typ (MHz)	Max (MHz)
Center frequency of operating channel	2412	—	2484

4.8.1 Wi-Fi RF Transmitter (TX) Specifications

Table 4-12. TX Power with Spectral Mask and EVM Meeting 802.11 Standards

Rate	Min (dBm)	Typ (dBm)	Max (dBm)
802.11b, 1 Mbps	—	21.0	—
802.11b, 11 Mbps	—	21.0	—
802.11g, 6 Mbps	—	21.0	—
802.11g, 54 Mbps	—	19.0	—
802.11n, HT20, MCS0	—	20.0	—
802.11n, HT20, MCS7	—	18.5	—
802.11n, HT40, MCS0	—	20.0	—
802.11n, HT40, MCS7	—	18.5	—

Table 4-13. TX EVM Test

Rate	Min (dB)	Typ (dB)	SL ¹ (dB)
802.11b, 1 Mbps, @21 dBm	—	-24.5	-10
802.11b, 11 Mbps, @21 dBm	—	-25.0	-10
802.11g, 6 Mbps, @21 dBm	—	-23.0	-5
802.11g, 54 Mbps, @19 dBm	—	-27.5	-25
802.11n, HT20, MCS0, @20 dBm	—	-22.5	-5
802.11n, HT20, MCS7, @18.5 dBm	—	-29.0	-27
802.11n, HT40, MCS0, @20 dBm	—	-22.5	-5
802.11n, HT40, MCS7, @18.5 dBm	—	-28.0	-27

¹ SL stands for standard limit value.

4.8.2 Wi-Fi RF Receiver (RX) Specifications

Table 4-14. RX Sensitivity

Rate	Min (dBm)	Typ (dBm)	Max (dBm)
802.11b, 1 Mbps	—	-98.4	—
802.11b, 2 Mbps	—	-96.0	—
802.11b, 5.5 Mbps	—	-93.0	—
802.11b, 11 Mbps	—	-88.6	—
802.11g, 6 Mbps	—	-93.8	—
802.11g, 9 Mbps	—	-92.2	—
802.11g, 12 Mbps	—	-91.0	—
802.11g, 18 Mbps	—	-88.4	—
802.11g, 24 Mbps	—	-85.8	—
802.11g, 36 Mbps	—	-82.0	—
802.11g, 48 Mbps	—	-78.0	—
802.11g, 54 Mbps	—	-76.6	—
802.11n, HT20, MCS0	—	-93.6	—
802.11n, HT20, MCS1	—	-90.8	—
802.11n, HT20, MCS2	—	-88.4	—
802.11n, HT20, MCS3	—	-85.0	—
802.11n, HT20, MCS4	—	-81.8	—
802.11n, HT20, MCS5	—	-77.8	—
802.11n, HT20, MCS6	—	-76.0	—
802.11n, HT20, MCS7	—	-74.8	—
802.11n, HT40, MCS0	—	-90.0	—
802.11n, HT40, MCS1	—	-88.0	—
802.11n, HT40, MCS2	—	-85.2	—
802.11n, HT40, MCS3	—	-82.0	—
802.11n, HT40, MCS4	—	-78.8	—
802.11n, HT40, MCS5	—	-74.6	—
802.11n, HT40, MCS6	—	-73.0	—
802.11n, HT40, MCS7	—	-71.4	—

Table 4-15. Maximum RX Level

Rate	Min (dBm)	Typ (dBm)	Max (dBm)
802.11b, 1 Mbps	—	5	—
802.11b, 11 Mbps	—	5	—
802.11g, 6 Mbps	—	5	—
802.11g, 54 Mbps	—	0	—
802.11n, HT20, MCS0	—	5	—

Cont'd on next page

Table 4-15 – cont'd from previous page

Rate	Min (dBm)	Typ (dBm)	Max (dBm)
802.11n, HT20, MCS7	—	0	—
802.11n, HT40, MCS0	—	5	—
802.11n, HT40, MCS7	—	0	—

Table 4-16. RX Adjacent Channel Rejection

Rate	Min (dB)	Typ (dB)	Max (dB)
802.11b, 1 Mbps	—	35	—
802.11b, 11 Mbps	—	35	—
802.11g, 6 Mbps	—	31	—
802.11g, 54 Mbps	—	20	—
802.11n, HT20, MCS0	—	31	—
802.11n, HT20, MCS7	—	16	—
802.11n, HT40, MCS0	—	25	—
802.11n, HT40, MCS7	—	11	—

4.9 Bluetooth LE Radio

Table 4-17. Bluetooth LE Frequency

Parameter	Min (MHz)	Typ (MHz)	Max (MHz)
Center frequency of operating channel	2402	—	2480

4.9.1 Bluetooth LE RF Transmitter (TX) Specifications

Table 4-18. Transmitter Characteristics - Bluetooth LE 1 Mbps

Parameter	Description	Min	Typ	Max	Unit
RF transmit power	RF power control range	-24.00	0	20.00	dBm
	Gain control step	—	3.00	—	dB
Carrier frequency offset and drift	Max $ f_n _{n=0, 1, 2, \dots, k}$	—	17.00	—	kHz
	Max $ f_0 - f_n $	—	1.75	—	kHz
	Max $ f_n - f_{n-5} $	—	1.46	—	kHz
	$ f_1 - f_0 $	—	0.80	—	kHz
Modulation characteristics	$\Delta f_{1\text{avg}}$	—	250.00	—	kHz
	Min $\Delta f_{2\text{max}}$ (for at least 99.9% of all $\Delta f_{2\text{max}}$)	—	190.00	—	kHz
	$\Delta f_{2\text{avg}}/\Delta f_{1\text{avg}}$	—	0.83	—	—

Cont'd on next page

Table 4-18 – cont'd from previous page

Parameter	Description	Min	Typ	Max	Unit
In-band spurious emissions	± 2 MHz offset	—	-37.62	—	dBm
	± 3 MHz offset	—	-41.95	—	dBm
	$> \pm 3$ MHz offset	—	-44.48	—	dBm

Table 4-19. Transmitter Characteristics - Bluetooth LE 2 Mbps

Parameter	Description	Min	Typ	Max	Unit
RF transmit power	RF power control range	-24.00	0	20.00	dBm
	Gain control step	—	3.00	—	dB
Carrier frequency offset and drift	$\text{Max } f_n _{n=0, 1, 2, \dots, k}$	—	20.80	—	kHz
	$\text{Max } f_0 - f_n $	—	1.30	—	kHz
	$\text{Max } f_n - f_{n-5} $	—	1.33	—	kHz
	$ f_1 - f_0 $	—	0.70	—	kHz
Modulation characteristics	$\Delta f_{1\text{avg}}$	—	498.00	—	kHz
	Min $\Delta f_{2\text{max}}$ (for at least 99.9% of all $\Delta f_{2\text{max}}$)	—	430.00	—	kHz
	$\Delta f_{2\text{avg}}/\Delta f_{1\text{avg}}$	—	0.93	—	—
In-band spurious emissions	± 4 MHz offset	—	-43.55	—	dBm
	± 5 MHz offset	—	-45.26	—	dBm
	$> \pm 5$ MHz offset	—	-45.26	—	dBm

Table 4-20. Transmitter Characteristics - Bluetooth LE 125 Kbps

Parameter	Description	Min	Typ	Max	Unit
RF transmit power	RF power control range	-24.00	0	20.00	dBm
	Gain control step	—	3.00	—	dB
Carrier frequency offset and drift	$\text{Max } f_n _{n=0, 1, 2, \dots, k}$	—	17.50	—	kHz
	$\text{Max } f_0 - f_n $	—	0.45	—	kHz
	$ f_n - f_{n-3} $	—	0.70	—	kHz
	$ f_0 - f_3 $	—	0.30	—	kHz
Modulation characteristics	$\Delta f_{1\text{avg}}$	—	250.00	—	kHz
	Min $\Delta f_{1\text{max}}$ (for at least 99.9% of all $\Delta f_{1\text{max}}$)	—	235.00	—	kHz
In-band spurious emissions	± 2 MHz offset	—	-37.90	—	dBm
	± 3 MHz offset	—	-41.00	—	dBm
	$> \pm 3$ MHz offset	—	-42.50	—	dBm

Table 4-21. Transmitter Characteristics - Bluetooth LE 500 Kbps

Parameter	Description	Min	Typ	Max	Unit
RF transmit power	RF power control range	-24.00	0	20.00	dBm
	Gain control step	—	3.00	—	dB

Cont'd on next page

Table 4-21 – cont'd from previous page

Parameter	Description	Min	Typ	Max	Unit
Carrier frequency offset and drift	Max $ f_n _{n=0, 1, 2, \dots, k}$	—	17.00	—	kHz
	Max $ f_0 - f_n $	—	0.88	—	kHz
	$ f_n - f_{n-3} $	—	1.00	—	kHz
	$ f_0 - f_3 $	—	0.20	—	kHz
Modulation characteristics	$\Delta f_{2_{avg}}$	—	208.00	—	kHz
	Min $\Delta f_{2_{max}}$ (for at least 99.9% of all $\Delta f_{2_{max}}$)	—	190.00	—	kHz
In-band spurious emissions	± 2 MHz offset	—	-37.90	—	dBm
	± 3 MHz offset	—	-41.30	—	dBm
	$> \pm 3$ MHz offset	—	-42.80	—	dBm

4.9.2 Bluetooth LE RF Receiver (RX) Specifications

Table 4-22. Receiver Characteristics - Bluetooth LE 1 Mbps

Parameter	Description	Min	Typ	Max	Unit
Sensitivity @30.8% PER	—	—	-97	—	dBm
Maximum received signal @30.8% PER	—	—	5	—	dBm
Co-channel C/I	—	—	8	—	dB
Adjacent channel selectivity C/I	F = FO + 1 MHz	—	-3	—	dB
	F = FO - 1 MHz	—	-4	—	dB
	F = FO + 2 MHz	—	-29	—	dB
	F = FO - 2 MHz	—	-31	—	dB
	F = FO + 3 MHz	—	-33	—	dB
	F = FO - 3 MHz	—	-27	—	dB
	F \geq FO + 4 MHz	—	-29	—	dB
F \leq FO - 4 MHz	—	-38	—	dB	
Image frequency	—	—	-29	—	dB
Adjacent channel to image frequency	F = F _{image} + 1 MHz	—	-41	—	dB
	F = F _{image} - 1 MHz	—	-33	—	dB
Out-of-band blocking performance	30 MHz ~ 2000 MHz	—	-5	—	dBm
	2003 MHz ~ 2399 MHz	—	-18	—	dBm
	2484 MHz ~ 2997 MHz	—	-15	—	dBm
	3000 MHz ~ 12.75 GHz	—	-5	—	dBm
Intermodulation	—	—	-30	—	dBm

Table 4-23. Receiver Characteristics - Bluetooth LE 2 Mbps

Parameter	Description	Min	Typ	Max	Unit
Sensitivity @30.8% PER	—	—	-93	—	dBm
Maximum received signal @30.8% PER	—	—	3	—	dBm
Co-channel C/I	—	—	10	—	dB

Cont'd on next page

Table 4-23 – cont'd from previous page

Parameter	Description	Min	Typ	Max	Unit
Adjacent channel selectivity C/I	$F = F_0 + 2 \text{ MHz}$	—	-7	—	dB
	$F = F_0 - 2 \text{ MHz}$	—	-7	—	dB
	$F = F_0 + 4 \text{ MHz}$	—	-28	—	dB
	$F = F_0 - 4 \text{ MHz}$	—	-26	—	dB
	$F = F_0 + 6 \text{ MHz}$	—	-26	—	dB
	$F = F_0 - 6 \text{ MHz}$	—	-27	—	dB
	$F \geq F_0 + 8 \text{ MHz}$	—	-29	—	dB
	$F \leq F_0 - 8 \text{ MHz}$	—	-28	—	dB
Image frequency	—	—	-28	—	dB
Adjacent channel to image frequency	$F = F_{image} + 2 \text{ MHz}$	—	-26	—	dB
	$F = F_{image} - 2 \text{ MHz}$	—	-7	—	dB
Out-of-band blocking performance	30 MHz ~ 2000 MHz	—	-5	—	dBm
	2003 MHz ~ 2399 MHz	—	-19	—	dBm
	2484 MHz ~ 2997 MHz	—	-16	—	dBm
	3000 MHz ~ 12.75 GHz	—	-5	—	dBm
Intermodulation	—	—	-29	—	dBm

Table 4-24. Receiver Characteristics - Bluetooth LE 125 Kbps

Parameter	Description	Min	Typ	Max	Unit
Sensitivity @30.8% PER	—	—	-105	—	dBm
Maximum received signal @30.8% PER	—	—	5	—	dBm
Co-channel C/I	—	—	3	—	dB
Adjacent channel selectivity C/I	$F = F_0 + 1 \text{ MHz}$	—	-6	—	dB
	$F = F_0 - 1 \text{ MHz}$	—	-6	—	dB
	$F = F_0 + 2 \text{ MHz}$	—	-33	—	dB
	$F = F_0 - 2 \text{ MHz}$	—	-43	—	dB
	$F = F_0 + 3 \text{ MHz}$	—	-37	—	dB
	$F = F_0 - 3 \text{ MHz}$	—	-47	—	dB
	$F \geq F_0 + 4 \text{ MHz}$	—	-40	—	dB
	$F \leq F_0 - 4 \text{ MHz}$	—	-50	—	dB
Image frequency	—	—	-40	—	dB
Adjacent channel to image frequency	$F = F_{image} + 1 \text{ MHz}$	—	-50	—	dB
	$F = F_{image} - 1 \text{ MHz}$	—	-37	—	dB

Table 4-25. Receiver Characteristics - Bluetooth LE 500 Kbps

Parameter	Description	Min	Typ	Max	Unit
Sensitivity @30.8% PER	—	—	-100	—	dBm
Maximum received signal @30.8% PER	—	—	5	—	dBm
Co-channel C/I	—	—	3	—	dB
Adjacent channel selectivity C/I	$F = F_0 + 1 \text{ MHz}$	—	-2	—	dB
	$F = F_0 - 1 \text{ MHz}$	—	-3	—	dB
	$F = F_0 + 2 \text{ MHz}$	—	-32	—	dB
	$F = F_0 - 2 \text{ MHz}$	—	-33	—	dB
	$F = F_0 + 3 \text{ MHz}$	—	-23	—	dB
	$F = F_0 - 3 \text{ MHz}$	—	-40	—	dB
	$F \geq F_0 + 4 \text{ MHz}$	—	-34	—	dB
	$F \leq F_0 - 4 \text{ MHz}$	—	-44	—	dB
Image frequency	—	—	-34	—	dB
Adjacent channel to image frequency	$F = F_{image} + 1 \text{ MHz}$	—	-46	—	dB
	$F = F_{image} - 1 \text{ MHz}$	—	-23	—	dB

5 Packaging

- For information about tape, reel, and chip marking, please refer to [Espressif Chip Packaging Information](#).
- The pins of the chip are numbered in anti-clockwise order starting from Pin 1 in the top view. For pin numbers and pin names, see also Figure 2-1 ESP32-C3 Pin Layout (Top View).
- The source file of [recommended PCB land pattern](#) is provided for your reference. You can view it with [Autodesk Viewer](#).
- For reference PCB layout, please refer to [ESP32-C3 Hardware Design Guidelines](#).

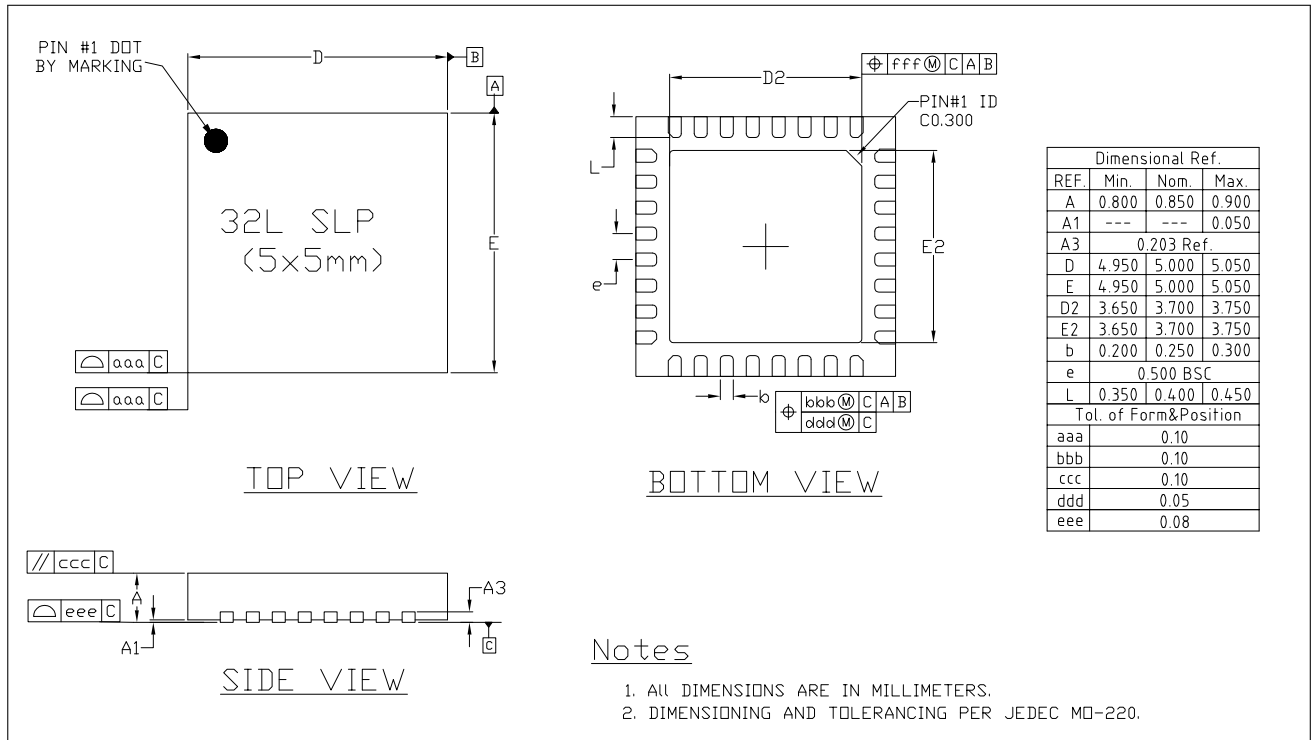

Figure 5-1. QFN32 (5x5 mm) Package

Appendix A – ESP32-C3 Consolidated Pin Overview

Pin No.	Pin Name	Pin Type	Pin Providing Power	Pin Settings		Analog Function		T
				At Reset	After Reset	0	1	
1	LNA_IN	Analog						0
2	VDD3P3	Power						
3	VDD3P3	Power						
4	XTAL_32K_P	IO	VDD3P3_RTC			XTAL_32K_P	ADC1_CH0	GPIO0
5	XTAL_32K_N	IO	VDD3P3_RTC			XTAL_32K_N	ADC1_CH1	GPIO1
6	GPIO2	IO	VDD3P3_RTC	IE	IE		ADC1_CH2	GPIO2
7	CHIP_EN	Analog						
8	GPIO3	IO	VDD3P3_RTC	IE	IE		ADC1_CH3	GPIO3
9	MTMS	IO	VDD3P3_RTC		IE		ADC1_CH4	MTMS
10	MTDI	IO	VDD3P3_RTC		IE		ADC2_CH0	MTDI
11	VDD3P3_RTC	Power						
12	MTCK	IO	VDD3P3_CPU		IE			MTCK
13	MTDO	IO	VDD3P3_CPU		IE			MTDO
14	GPIO8	IO	VDD3P3_CPU	IE	IE			GPIO8
15	GPIO9	IO	VDD3P3_CPU	IE, WPU	IE, WPU			GPIO9
16	GPIO10	IO	VDD3P3_CPU		IE			GPIO10
17	VDD3P3_CPU	Power						
18	VDD_SPI	Power	VDD3P3_CPU					GPIO11
19	SPIHD	IO	VDD_SPI / VDD3P3_CPU	WPU	IE, WPU			SPIHD
20	SPIWP	IO	VDD_SPI / VDD3P3_CPU	WPU	IE, WPU			SPIWP
21	SPICSO	IO	VDD_SPI / VDD3P3_CPU	WPU	IE, WPU			SPICSO
22	SPICLK	IO	VDD_SPI / VDD3P3_CPU	WPU	IE, WPU			SPICLK
23	SPIID	IO	VDD_SPI / VDD3P3_CPU	WPU	IE, WPU			SPIID
24	SPIQ	IO	VDD_SPI / VDD3P3_CPU	WPU	IE, WPU			SPIQ
25	GPIO18	IO	VDD3P3_CPU			USB_D-		GPIO18
26	GPIO19	IO	VDD3P3_CPU			USB_D+		GPIO19
27	UORXD	IO	VDD3P3_CPU		IE, WPU			UORXD
28	UOTXD	IO	VDD3P3_CPU		WPU			UOTXD
29	XTAL_N	Analog						
30	XTAL_P	Analog						
31	VDDA	Power						
32	VDDA	Power						
33	GND	Power						

* For details, see Section 2 Pins. Regarding highlighted cells, see Section 2.3.3 Restrictions for GPIOs.

Related Documentation and Resources

Related Documentation

- [ESP32-C3 Technical Reference Manual](#) – Detailed information on how to use the ESP32-C3 memory and peripherals.
- [ESP32-C3 Hardware Design Guidelines](#) – Guidelines on how to integrate the ESP32-C3 into your hardware product.
- [ESP32-C3 Series SoC Errata](#) – Descriptions of known errors in ESP32-C3 series of SoCs.
- *Certificates*
<https://espressif.com/en/support/documents/certificates>
- *ESP32-C3 Product/Process Change Notifications (PCN)*
<https://espressif.com/en/support/documents/pcns?keys=ESP32-C3>
- *ESP32-C3 Advisories* – Information on security, bugs, compatibility, component reliability.
<https://espressif.com/en/support/documents/advisories?keys=ESP32-C3>
- *Documentation Updates and Update Notification Subscription*
<https://espressif.com/en/support/download/documents>

Developer Zone

- [ESP-IDF Programming Guide for ESP32-C3](#) – Extensive documentation for the ESP-IDF development framework.
- *ESP-IDF* and other development frameworks on GitHub.
<https://github.com/espressif>
- *ESP32 BBS Forum* – Engineer-to-Engineer (E2E) Community for Espressif products where you can post questions, share knowledge, explore ideas, and help solve problems with fellow engineers.
<https://esp32.com/>
- *The ESP Journal* – Best Practices, Articles, and Notes from Espressif folks.
<https://blog.espressif.com/>
- See the tabs *SDKs and Demos, Apps, Tools, AT Firmware*.
<https://espressif.com/en/support/download/sdks-demos>

Products

- *ESP32-C3 Series SoCs* – Browse through all ESP32-C3 SoCs.
<https://espressif.com/en/products/socs?id=ESP32-C3>
- *ESP32-C3 Series Modules* – Browse through all ESP32-C3-based modules.
<https://espressif.com/en/products/modules?id=ESP32-C3>
- *ESP32-C3 Series DevKits* – Browse through all ESP32-C3-based devkits.
<https://espressif.com/en/products/devkits?id=ESP32-C3>
- *ESP Product Selector* – Find an Espressif hardware product suitable for your needs by comparing or applying filters.
<https://products.espressif.com/#/product-selector?language=en>

Contact Us

- See the tabs *Sales Questions, Technical Enquiries, Circuit Schematic & PCB Design Review, Get Samples* (Online stores), *Become Our Supplier, Comments & Suggestions*.
<https://espressif.com/en/contact-us/sales-questions>

Revision History

Date	Version	Release notes
2024-04-01	v1.7	<ul style="list-style-type: none"> Marked the ESP32-C3FN4 variant as end of life Marked the ESP32-C3FH4AZ variant as NRND Marked the ESP32-C3FH4X variant as recommended
2024-01-19	v1.6	<ul style="list-style-type: none"> Added the new ESP32-C3FH4X and ESP32-C3FH4XAZ variants in Chapter 1 ESP32-C3 Series Comparison Corrected the PWM duty resolution to 14 bits in Section 3.4.7 LED PWM Controller
2023-08-11	v1.5	<ul style="list-style-type: none"> Marked ESP32-C3FN4 as NRND Improved the content in the following sections: <ul style="list-style-type: none"> Section Product Overview Section 2 Pins Section 3.7 Power Management Section 3.4.2 Serial Peripheral Interface (SPI) Section 4.1 Absolute Maximum Ratings Section 4.2 Recommended Operating Conditions Section 4.3 VDD_SPI Output Characteristics Section 4.5 ADC Characteristics Added Appendix A Updated the maximum value of "RF power control range" to 20 dBm in Section 4.9 Bluetooth LE Radio Other minor updates
2022-12-15	v1.4	<ul style="list-style-type: none"> Deleted feature "Antenna diversity" from Section 3.6.1 Bluetooth LE Radio and PHY Deleted feature "Supports external power amplifier" Updated the glitch type of GPIO18 to high-level glitch in Table Pin Overview

Cont'd on next page

Cont'd from previous page

Date	Version	Release notes
2022-11-15	v1.3	<ul style="list-style-type: none"> • Updated notes for Table Pin Overview • Added links to the Technical Reference Manual and Peripheral Pin Configurations in Chapter 3 Functional Description • Added a note about ADC2 error in Section 3.3.1 Analog-to-Digital Converter (ADC) • Updated Section 3.8.3 Watchdog Timers • Added Table ADC Characteristics • Updated Section 4.6.2 Current Consumption in Other Modes • Updated RF transmit power in Section 4.9 Bluetooth LE Radio • Updated the typo in Section 5 Packaging • Updated Chapter Related Documentation and Resources
2022-04-13	v1.2	<ul style="list-style-type: none"> • Added a new chip variant ESP32-C3FH4AZ; • Updated Figure ESP32-C3 Functional Block Diagram; • Added the wake up source for Deep-sleep mode in Section 3.7 Power Management.
2021-10-26	v1.1	<ul style="list-style-type: none"> • Updated Figure ESP32-C3 Functional Block Diagram to show power modes; • Added CoreMark score in Features; • Updated Table Pin Description to show default pin functions; • Updated Figure ESP32-C3 Power Scheme and related descriptions; • Added Table SPI Signals; • Added note 3 to Table Recommended Operating Conditions; • Other updates to wording.
2021-05-28	v1.0	<ul style="list-style-type: none"> • Updated power modes; • Updated Section 2.6 Strapping Pins; • Updated some clock names and their frequencies in Section 3.2 System Clocks; • Added clarification about ADC1 and ADC2 in Section 3.3.1 Analog-to-Digital Converter (ADC); • Updated the default configuration of UORXD and UOTXD after reset in Table IO MUX; • Updated sampling rate in Table ADC Characteristics; • Updated Table Reliability; • Added the link to recommended PCB land pattern in Chapter 5 Packaging.
2021-04-23	v0.8	Updated Wi-Fi Radio and Bluetooth LE Radio data.

Cont'd on next page

Cont'd from previous page

Date	Version	Release notes
2021-04-07	v0.7	<ul style="list-style-type: none"> ● Updated information about USB Serial/JTAG Controller; ● Added GPIO2 to Section 2.6 Strapping Pins; ● Updated Figure Address Mapping Structure; ● Added Table IO MUX and Table Pin Overview in Section 3.4.1 General Purpose Input / Output Interface (GPIO); ● Updated information about SPI2 in Section 3.4.2 Serial Peripheral Interface (SPI); ● Updated fixed-priority channel scheme in Section 3.4.8 General DMA Controller; ● Updated Table Reliability.
2021-01-18	v0.6	<ul style="list-style-type: none"> ● Clarified that of the 400 KB SRAM, 16 KB is configured as cache; ● Updated maximum value to standard limit value in Table Wi-Fi RF Transmitter (TX) Specifications in Section 4.8.1 Wi-Fi RF Transmitter (TX) Specifications.
2021-01-13	v0.5	<ul style="list-style-type: none"> ● Updated information about Wi-Fi; ● Added connection between in-package flash ports and chip pins to table notes in Section Pin Definitions; ● Updated Figure ESP32-C3 Power Scheme, added Figure Visualization of Timing Parameters for Power-up and Reset and Table Description of Timing Parameters for Power-up and Reset in Section 2.5.2 Power Scheme; ● Added Figure Visualization of Timing Parameters for the Strapping Pins and Table Description of Timing Parameters for the Strapping Pins in Section 2.6 Strapping Pins; ● Updated Table Peripheral Pin Configurations in Section 3.11 Peripheral Pin Configurations; ● Added Chapter 4 Electrical Characteristics; ● Added Chapter 5 Packaging.
2020-11-27	v0.4	Preliminary version.



www.espressif.com

Disclaimer and Copyright Notice

Information in this document, including URL references, is subject to change without notice.

ALL THIRD PARTY' S INFORMATION IN THIS DOCUMENT IS PROVIDED AS IS WITH NO WARRANTIES TO ITS AUTHENTICITY AND ACCURACY.

NO WARRANTY IS PROVIDED TO THIS DOCUMENT FOR ITS MERCHANTABILITY, NON-INFRINGEMENT, FITNESS FOR ANY PARTICULAR PURPOSE, NOR DOES ANY WARRANTY OTHERWISE ARISING OUT OF ANY PROPOSAL, SPECIFICATION OR SAMPLE.

All liability, including liability for infringement of any proprietary rights, relating to use of information in this document is disclaimed. No licenses express or implied, by estoppel or otherwise, to any intellectual property rights are granted herein.

The Wi-Fi Alliance Member logo is a trademark of the Wi-Fi Alliance. The Bluetooth logo is a registered trademark of Bluetooth SIG.

All trade names, trademarks and registered trademarks mentioned in this document are property of their respective owners, and are hereby acknowledged.





Copyright © 2024 Espressif Systems (Shanghai) Co., Ltd. All rights reserved.

Looking for pricing, stock, or lifecycle information?

Click below to explore more details on WIN SOURCE:

-  [View ESP32-C3-DEVKITM-1 on WIN SOURCE](#)
-  [Espressif Information](#)

Optimize Your Supply Chain with WIN SOURCE Solutions

-  Global Sourcing Solution
-  Obsolete Management
-  Cost Control Management
-  Shortage Management
-  Alternative Solution
-  Excess Inventory Management