



THE DATASHEET OF PL-USB2-BLASTER





Intel[®] FPGA Download Cable User Guide



Online Version



Send Feedback

UG-USB81204

ID: **683076**

Version: **2020.03.11**

Contents

1. Introduction to Intel® FPGA Download Cable.....	3
1.1. Intel FPGA Download Cable Revision.....	3
1.2. Supported Devices and Host Systems.....	3
2. Specifications for Intel FPGA Download Cable.....	4
2.1. Block Diagram and Dimension.....	4
2.2. Cable-to-Board Connection.....	4
2.3. Pin Description.....	5
2.4. Operating Conditions.....	6
2.5. Power Requirements.....	7
2.6. RoHS Compliance.....	8
3. Using the Intel FPGA Download Cable.....	9
3.1. Installing the Intel FPGA Download Cable Driver on Windows.....	9
3.2. Installing the Intel FPGA Download Cable Driver on Linux.....	9
3.2.1. Installing on Red Hat Enterprise 4 or Earlier Versions.....	10
3.2.2. Installing on Red Hat Enterprise 5 and 6.....	10
3.3. Setting up the Intel FPGA Download Cable Hardware in the Intel Quartus Prime Software.....	10
3.4. Connecting the Intel FPGA Download Cable to the Board.....	11
A. Additional Information.....	13
A.1. Windows Troubleshooting Procedure for Intel FPGA Download Cable.....	13
A.1.1. Jtagconfig version setting (Intel Quartus Prime software root directory setting)	13
A.1.2. Jtagserver Setting.....	14
A.1.3. Install/Reinstall the Intel FPGA Download Cable driver	14
A.2. Troubleshooting Procedure for Error when scanning hardware - No Devices.....	15
B. Revision History.....	16

1. Introduction to Intel® FPGA Download Cable

The Intel® FPGA Download Cable interfaces a USB port on a host computer to an FPGA mounted on a printed circuit board. The cable sends configuration data from the host computer to a standard 10-pin header connected to the FPGA. You can use the Intel FPGA Download Cable to iteratively download configuration data to a system during prototyping or to program data into the system during production.

1.1. Intel FPGA Download Cable Revision

Table 1. Intel FPGA Download Cable Revision

Revision	Indicator	Description	RoHS Compliant
Rev. A	Ribbon cable. No revision marking on the casing.	10-pin female connector that is connected to the Intel FPGA Download Cable through a ribbon cable.	No
Rev. B	"Rev. B" on the casing.	10-pin female connector that is connected to the Intel FPGA Download Cable through a flexible PCB cable.	No
Rev. C	"Rev. C" on the casing.	10-pin female connector that is connected to the Intel FPGA Download Cable through a flexible PCB cable.	Yes

1.2. Supported Devices and Host Systems

You can use the Intel FPGA Download Cable with supported Intel FPGAs, serial configuration devices, and host systems.

Table 2. Supported Devices and Host Systems

FPGA	Serial Configuration Device	Host System
Stratix® series Arria® series Cyclone® series MAX® series	EPCS devices EPCQ devices EPCQ-L devices	Windows Linux

2. Specifications for Intel FPGA Download Cable

The Intel FPGA Download Cable has a universal USB connector that plugs into the PC USB port, and a female connector that plugs into a male header on the device board. This section shows the hardware components, their dimensions, and lists the pins, operating conditions and power requirements.

2.1. Block Diagram and Dimension

Figure 1. Block Diagram of the Intel FPGA Download Cable

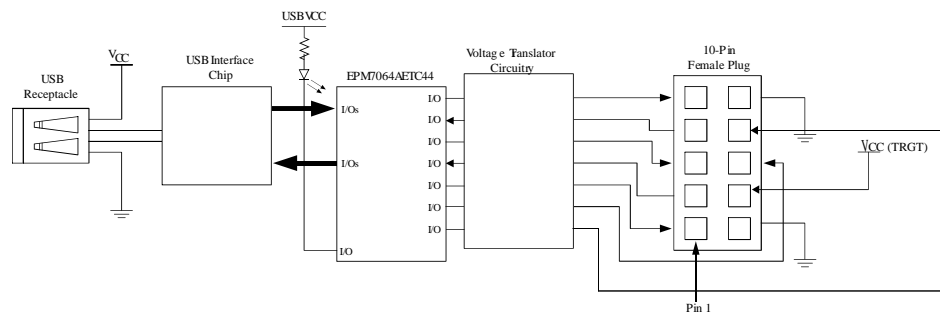
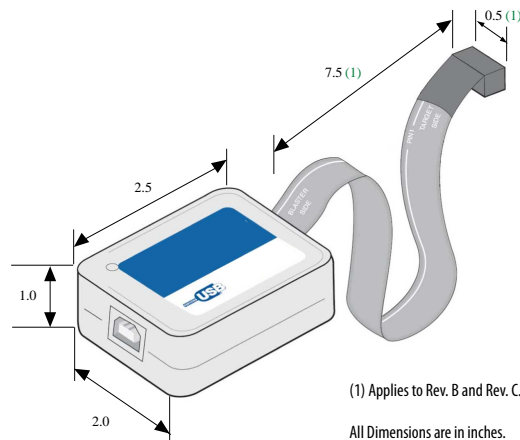

Figure 2. Dimension of the Intel FPGA Download Cable



2.2. Cable-to-Board Connection

The Intel FPGA Download Cable has a 10-pin female connector, which plugs into a 10-pin male header on the device board. The male header consists of two rows of five pins, which are connected to the programming or configuration pins of the device.

A 10-pin surface mount header can be used for the JTAG, AS, or PS download cable. However, Intel recommends using a through-hole connector because of the repeated insertion and removal force needed.

Figure 3. Connectors and Dimensions

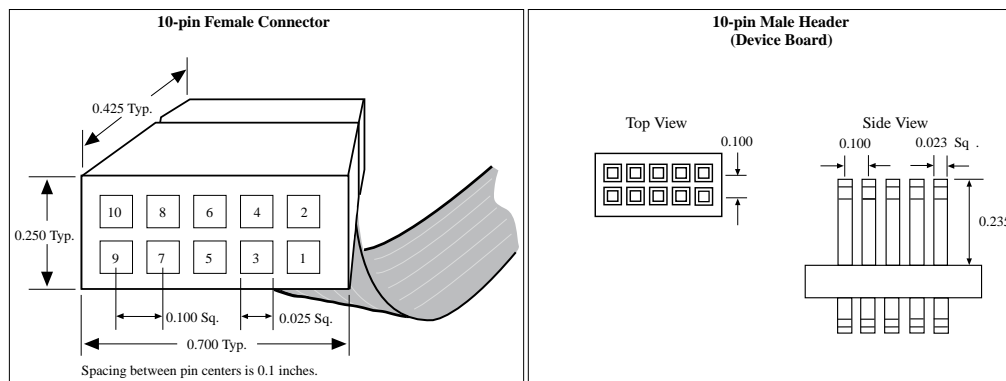

Dimensions are in inches

2.3. Pin Description

The following table lists the pins of the Intel FPGA Download Cable female plug and describes their functions in the JTAG, active serial and passive serial modes.

Table 3. Signal Names of the Intel FPGA Download Cable Female Plug

Pin	AS Mode		PS Mode		JTAG Mode	
	Signal Name	Description	Signal Name	Description	Signal Name	Description
1	DCLK	Clock signal.	DCLK	Clock signal.	TCK	Clock signal.
2	GND	Signal ground.	GND	Signal ground.	GND	Signal ground.
3	CONF_DONE	Configuration done.	CONF_DONE	Configuration done.	TDO	Data from device.
4	V _{CC(TRGT)}	Target power supplied by the device board.	V _{CC(TRGT)}	Target power supplied by the device board.	V _{CC(TRGT)}	Target power supplied by the device board.
5	nCONFIG	Configuration control.	nCONFIG	Configuration control.	TMS	JTAG state machine control.
6	nCE	Cyclone chip enable.	—	—	—	—
7	DATAOUT	Active serial data out.	nSTATUS	Configuration status.	—	—
8	nCS	Serial configuration device chip select.	—	—	—	—
9	ASDI	Active serial data in.	DATA0	Data to device.	TDI	Data to device.
10	GND	Signal ground.	GND	Signal ground.	GND	Signal ground.

2.4. Operating Conditions

Use the provided maximum ratings, recommended operating conditions and DC operating conditions to ensure the correct usage of the Intel FPGA Download Cable.

Table 4. Absolute Maximum Ratings

Symbol	Parameter	Conditions	Min	Max	Unit
$V_{CC(TRGT)}$	Target supply voltage	With respect to ground	-0.3	5.5	V
$V_{CC(USB)}$	USB supply voltage	With respect to ground	-0.5	6.0	V
I_I	Input current	TDO or dataout	-10.0	10.0	mA
I_o	Output current for Rev. A or Rev. B cable	TCK, TMS, TDI, nCS, nCE	-20.0	20.0	mA
	Output current for Rev. C cable		-50.0	50.0	mA

Table 5. Recommended Operating Conditions

Symbol	Parameter	Conditions	Min	Max	Unit
$V_{CC(TRGT)}$	Target supply voltage, 5.0-V operation	—	4.75	5.25	V
	Target supply voltage, 3.3-V operation	—	3.0	3.6	V
	Target supply voltage, 2.5-V operation	—	2.375	2.625	V
	Target supply voltage, 1.8-V operation	—	1.71	1.89	V
	Target supply voltage, 1.5-V operation	—	1.43	1.57	V

Table 6. DC Operating Conditions for Intel FPGA Download Cable Rev. A and B

Symbol	Parameter	Conditions	Min	Max	Unit
V_{IH}	High-level input voltage	—	$V_{CC(TRGT)} - 0.2$	—	V
V_{IL}	Low-level input voltage	—	—	0.15	V
V_{OH}	5.0-V high-level output voltage	$V_{CC(TRGT)} = 4.5\text{ V}, I_{OH} = 1\text{ mA}$	4.4	—	V
	3.3-V high-level output voltage	$V_{CC(TRGT)} = 3.0\text{ V}, I_{OH} = 1\text{ mA}$	2.9	—	V
	2.5-V high-level output voltage	$V_{CC(TRGT)} = 2.375\text{ V}, I_{OH} = 1\text{ mA}$	2.275	—	V
	1.8-V high-level output voltage	$V_{CC(TRGT)} = 1.71\text{ V}, I_{OH} = 1\text{ mA}$	1.61	—	V
	1.5-V high-level output voltage	$V_{CC(TRGT)} = 1.43\text{ V}, I_{OH} = 1\text{ mA}$	1.33	—	V
V_{OL}	5.0-V low-level output voltage	$V_{CC(TRGT)} = 5.5\text{ V}, I_{OL} = 1\text{ mA}$	—	0.125	V

continued...

Symbol	Parameter	Conditions	Min	Max	Unit
	3.3-V low-level output voltage	$V_{CC(TRGT)} = 3.6 \text{ V}, I_{OL} = 1 \text{ mA}$	—	0.125	V
	2.5-V low-level output voltage	$V_{CC(TRGT)} = 2.625 \text{ V}, I_{OL} = 1 \text{ mA}$	—	0.125	V
	1.8-V low-level output voltage	$V_{CC(TRGT)} = 1.89 \text{ V}, I_{OL} = 1 \text{ mA}$	—	0.125	V
	1.5-V low-level output voltage	$V_{CC(TRGT)} = 1.57 \text{ V}, I_{OL} = 1 \text{ mA}$	—	0.125	V
$I_{CC(TRGT)}$	Operating current (No Load)	Typical $I_{CC(TRGT)} = 16 \text{ uA}$	—	100	μA

Table 7. DC Operating Conditions for Intel FPGA Download Cable Rev. C

Symbol	Parameter	Conditions	Min	Max	Unit
V_{IH}	High-level input voltage	$V_{CC(TRGT)} \geq 2.0 \text{ V}$	2.0	—	V
		$V_{CC(TRGT)} < 2.0 \text{ V}$	$V_{CC(TRGT)}$	—	V
V_{IL}	Low-level input voltage	$V_{CC(TRGT)} \geq 2.0 \text{ V}$	—	0.8	V
		$V_{CC(TRGT)} < 2.0 \text{ V}$	—	0	V
V_{OH}	5.0-V high-level output voltage	$V_{CC(TRGT)} = 4.5 \text{ V}, I_{OH} = -10 \text{ mA}$	3.8	—	V
	3.3-V high-level output voltage	$V_{CC(TRGT)} = 3.0 \text{ V}, I_{OH} = -8 \text{ mA}$	2.3	—	V
	2.5-V high-level output voltage	$V_{CC(TRGT)} = 2.375 \text{ V}, I_{OH} = -6 \text{ mA}$	1.8	—	V
	1.8-V high-level output voltage	$V_{CC(TRGT)} = 1.71 \text{ V}, I_{OH} = -4 \text{ mA}$	1.2	—	V
V_{OL}	5.0-V high-level output voltage	$V_{CC(TRGT)} = 5.5 \text{ V}, I_{OL} = 10 \text{ mA}$	—	0.8	V
	3.3-V high-level output voltage	$V_{CC(TRGT)} = 3.6 \text{ V}, I_{OL} = 8 \text{ mA}$	—	0.7	V
	2.5-V high-level output voltage	$V_{CC(TRGT)} = 2.625 \text{ V}, I_{OL} = 6 \text{ mA}$	—	0.6	V
	1.8-V high-level output voltage	$V_{CC(TRGT)} = 1.89 \text{ V}, I_{OL} = 4 \text{ mA}$	—	0.5	V
$I_{CC(TRGT)}$	Operating current (No Load)	Typical $I_{CC(TRGT)} = 16 \text{ uA}$	—	100	μA

2.5. Power Requirements

The Intel FPGA Download Cable $V_{CC(TRGT)}$ pin must be connected to a specific voltage for the device being programmed. Connect pull-up resistors to the same power supply as the Intel FPGA Download Cable $V_{CC(TRGT)}$.

Table 8. $V_{CC(TRGT)}$ Power Requirements

Device Family	Voltage Required
FPGAs	
Stratix V, Stratix IV, and Stratix III	As specified by V_{CCPGM} or V_{CCPD} .
Stratix II, Stratix II GX, and Stratix GX	As specified by V_{CCSEL} .
Arria 10	As specified by V_{CCPGM} or V_{CCIO} .
Arria V	As specified by V_{CCPD} .
Arria II GX	As specified by V_{CCPD} or V_{CCIO} of Bank 8C
Arria GX	As specified by V_{CCSEL} .
Cyclone V	As specified by V_{CCPGM} or V_{CCPD} .
Cyclone IV	As specified by V_{CCA} or V_{CCIO} .
Cyclone III	As specified by V_{CCA} or V_{CCIO} .
Max 10	As specified by V_{CCIO} .
Configuration Devices	
EPCS	3.3 V
EPCQ	3.3 V
EPCQ-L	1.8 V

2.6. RoHS Compliance

Table 9. Hazardous Substances and Concentration

A value of 0 indicates that the concentration of the hazardous substance in all homogeneous materials in the parts is below the relevant threshold as specified by the SJ/T11363-2006 standard.

Part Name	Lead (Pb)	Cadmium (Cd)	Hexavalent Chromium (Cr6+)	Mercury (Hg)	Polybrominated Biphenyls (PBB)	Polybrominated Diphenyl Ethers (PBB)
Electronic components	0	0	0	0	0	0
Populated circuit board	0	0	0	0	0	0
Manufacturing process	0	0	0	0	0	0
Packing	0	0	0	0	0	0

3. Using the Intel FPGA Download Cable

To start using the Intel FPGA Download Cable, you must install the drivers on your system and set up the hardware in the Intel Quartus® Prime software. Intel recommends that you use the latest version of the Intel Quartus Prime software.

To program or configure the device, connect the host system to the device board using the Intel FPGA Download Cable and initiate the programming or configuration using the Intel Quartus Prime Programmer. You can also use the cable with the Intel Quartus Prime Signal Tap Logic Analyzer for logic analysis.

3.1. Installing the Intel FPGA Download Cable Driver on Windows

1. Locate the Intel FPGA Download Cable driver in `\<Quartus Prime system directory>\drivers\usb-blaster`.

If the driver is not in your directory, download the driver from www.altera.com/support/software/drivers.

2. Connect the Intel FPGA Download Cable to your PC.
3. Open **Device Manager**. In the **Other devices** tab, select and right click **USB-Blaster**. Then, click **Update Driver Software**.
4. Click **Browse**. Browse to `\<Quartus Prime system directory>\drivers\usb-blaster` and click **Next**.
The Windows security warning is displayed.
5. Click **Install** to begin installing the driver.
6. Click **Finish** when the driver is installed.
7. Restart your system.

Related Information

[Cable and Adapter Drivers Information](#)

3.2. Installing the Intel FPGA Download Cable Driver on Linux

The Intel Quartus Prime software uses the USB drivers (usbfs) provided by Red Hat Linux to access the Intel FPGA Download Cable. You need system administration (root) privileges to configure the drivers. You must also change the permission on the ports before using the Intel FPGA Download Cable to program devices.

Related Information

[Cable and Adapter Drivers Information](#)

3.2.1. Installing on Red Hat Enterprise 4 or Earlier Versions

1. Add the following lines to the `/etc/hotplug/usb.usermap` file:

```
#
#Intel FPGA Download Cable
#
usbblaster 0x03 0x09fb 0x6001 0x0 0x0 0x0 0x0 0x0 0x0 0x0 0x0 0x0
usbblaster 0x03 0x09fb 0x6002 0x0 0x0 0x0 0x0 0x0 0x0 0x0 0x0 0x0
usbblaster 0x03 0x09fb 0x6003 0x0 0x0 0x0 0x0 0x0 0x0 0x0 0x0 0x0
```

2. Create a file named `/etc/hotplug/usb/usbblaster` and write:

```
#!/bin/sh
#Intel FPGA Download Cable hotplug script
# Allow any user to access the cable
chmod 666 $DEVICE
```

3. Make the file executable.

Now you can set up the programming hardware in the Intel Quartus Prime software.

3.2.2. Installing on Red Hat Enterprise 5 and 6

1. Create a file named `/etc/udev/rules.d/51-usbblaster.rules`
2. In the file, add the following lines, depending on the type of download cable.

Ensure that all the code is in one line.

- Intel FPGA Download Cable:

```
BUS=="usb", SYSFS{idVendor}=="09fb", SYSFS{idProduct}=="6001",
MODE="0666"
BUS=="usb", SYSFS{idVendor}=="09fb", SYSFS{idProduct}=="6002",
MODE="0666"
BUS=="usb", SYSFS{idVendor}=="09fb", SYSFS{idProduct}=="6003",
MODE="0666"
```

- Intel FPGA Download Cable II:

```
BUS=="usb", SYSFS{idVendor}=="09fb", SYSFS{idProduct}=="6010",
MODE="0666"
BUS=="usb", SYSFS{idVendor}=="09fb", SYSFS{idProduct}=="6810",
MODE="0666"
```

Now you can set up the programming hardware in the Intel Quartus Prime software.

3.3. Setting up the Intel FPGA Download Cable Hardware in the Intel Quartus Prime Software

1. Launch the Intel Quartus Prime software.
2. Click **Tools > Programmer**.
3. Click **Hardware Setup**.

Figure 4. Hardware Setup Dialog Box

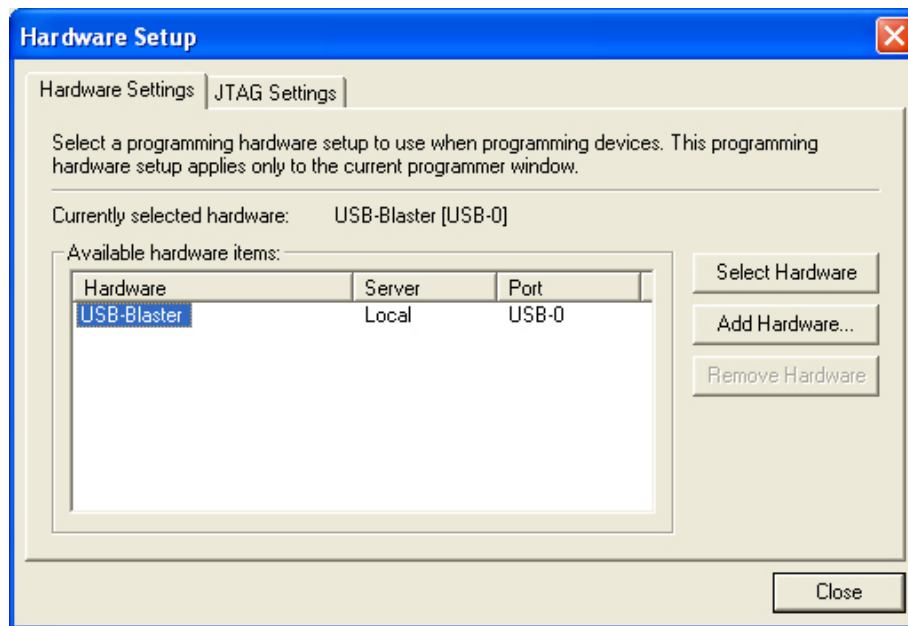

The **Hardware Settings** tab of the **Hardware Setup** dialog box is displayed.

4. From the **Currently selected hardware** drop-down list, select **USB-Blaster [USB-0]**.
5. Click **Close** to close the **Hardware Setup** dialog box.
6. In the **Programmer** window, select the desired programming mode from the **Mode** drop-down list.

Table 10. Programming Modes

Mode	Description
Joint Test Action Group (JTAG)	Programs or configures all supported Intel devices except EPCS, EPCQ, and EPCQ-L devices.
In-Socket Programming	USB-Blaster does not support this programming mode.
Passive Serial	Configures all supported Intel devices except EPCS, EPCQ, and EPCQ-L devices.
Active Serial Programming	Programs a single EPCS, EPCQ, or EPCQ-L device.

3.4. Connecting the Intel FPGA Download Cable to the Board

1. Disconnect the power cable from the device board.
2. Connect the Intel FPGA Download Cable to your PC.
3. Plug the Intel FPGA Download Cable into the 10-pin header on the device board.

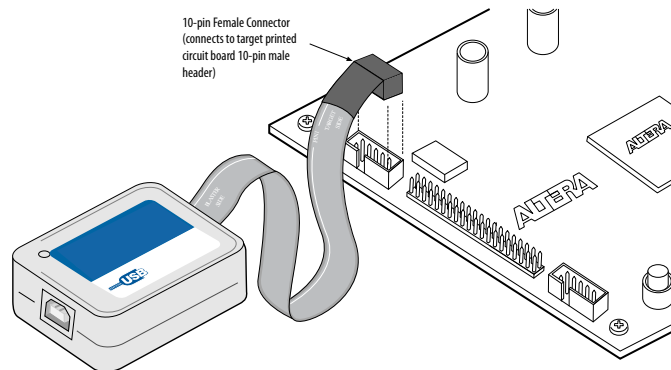
Figure 5. Connection to the Device Board

4. Connect the power cable to the device board.
The **Found New Hardware** wizard may open and prompt you to install a new hardware driver. Close the wizard and follow the steps provided in subsequent sections to install the hardware driver.
5. To disconnect the Intel FPGA Download Cable from the device board, follow these steps to ensure that the cable is not damaged.
 - a. Remove power from the device board.
 - b. Unplug the Intel FPGA Download Cable from the board.
 - c. Unplug the Intel FPGA Download Cable from your PC.

A. Additional Information

A.1. Windows Troubleshooting Procedure for Intel FPGA Download Cable

In the Windows version of the Intel Quartus Prime software, you may encounter that the Intel FPGA Download Cable may occasionally not work well; although you may not observe any problems in the physical connections. In many cases, it is due to:

- Incorrect Windows settings or some unknown problem with the Intel FPGA Download Cable driver
- The version of JTAG related software like **Jtagconfig** or **Jtagserver** not matching the version of Intel Quartus Prime software
- The version of the Intel FPGA Download Cable driver is old, not proper, or corrupted

The troubleshooting steps are listed in the following sections.

A.1.1. Jtagconfig version setting (Intel Quartus Prime software root directory setting)

1. Open a command prompt of Windows OS
2. Execute the following command: `Jtagconfig -v`

Example message:

```
Version 18.1.1 Build 646 04/11/2019 SJ Standard Edition
```

3. If the version in the message does not match the Intel Quartus Prime version that you use, you must modify the user system variables for your Windows account or the system variables.

A.1.1.1. Automatic Setting

1. Go to `<Quartus Prime software install folder>\quartus\bin64` for Intel Quartus Prime. Go to `<Quartus Prime Programmer install folder>\qprogrammer\bin64` or `<Quartus Prime Programmer install directory>\qprogrammer\quartus\bin64` for Intel Quartus Prime Programmer tool.

2. Execute the following command:

```
qreg.exe --force -jtag -setqdir
```

3. Intel recommends you verify the environment variables using the manual setting procedure explained in the section below.

A.1.1.2. Manual Setting

1. Open Environment Variables window of Windows OS
Windows Settings > Type "Environment" into the search area > Choose Edit the system environment variables
2. Check if Path variable has %QUARTUS_ROOTDIR%\bin64 in System variables or User variables for your account. If not present, add %QUARTUS_ROOTDIR%\bin64
3. Check if QUARTUS_ROOTDIR variable is in a right path that **bin64** folder locates
Directory for Intel Quartus Prime: <Quartus Prime software install folder>\quartus
Directory for Intel Quartus Prime Programmer tool: < Quartus Prime Programmer install folder>\qprogrammer or < Quartus Prime Programmer install directory>\qprogrammer\quartus
4. If you notice these variables in both System variables or User variables for your account, Intel recommends that one of them should be deleted.
5. Restart your computer and check the version of **jtagconfig** using step 1 and 2

A.1.2. Jtagserver Setting

1. Open Windows OS command prompt
2. Execute the following command: `jtagconfig --serverinfo`

Example message is

```
Installed JTAG server is '<Quartus Prime install folder>\quartus
\bin64\jtagserver.exe'
Service manager reports server is running
Server reports path: <Quartus Prime install folder>\quartus
\bin64\jtagserver.exe
Server reports version: Version 18.1.1 Build 646 04/11/2019 SJ Standard
Edition
Remote clients are disabled (no password)
```

If the installed JTAG server doesn't match the version of Intel Quartus Prime software you use, install the same version of JTAG server as the Intel Quartus Prime software.

3. Set the environment variables correctly following the steps described in the **jtagconfig** version setting in the sections above.
4. Execute the following command

```
Jtagserver -uninstall
Jtagserver -install
```
5. Restart your computer

A.1.3. Install/Reinstall the Intel FPGA Download Cable driver

1. Connect your Intel FPGA Download Cable or Intel FPGA Download Cable II
2. Open **Device Manager** window of Windows OS

Windows Settings > Type "Device Manager" into the search area
> Choose Device Manager

3. Find Intel FPGA Download Cable II under JTAG cables or Intel FPGA Download Cable under Universal Serial Bus controllers
4. Choose Intel FPGA Download Cable or Intel FPGA Download Cable II
5. Right click and choose **Uninstall device** from context menu
6. Enable **Delete the driver software for this device** and click **Uninstall**
7. If you see another Intel FPGA Download Cable or Intel FPGA Download Cable II, uninstall it too
8. Reinstall the drivers following the steps in section [Installing the Intel FPGA Download Cable Driver on Windows](#) on page 9

A.2. Troubleshooting Procedure for Error when scanning hardware - No Devices

You might see this error when connecting multiple download cables to your computer and executing `jtagconfig` command.

```
Error when scanning hardware - No devices
```

It takes a certain finite amount of time for your computer to finish the USB device enumeration after connecting USB devices. The more USB devices are connected, the more time is required for the USB device enumeration.

The above error occurs when `jtagconfig` command is executed before your computer finishes the USB device enumeration to recognize all download cables connected. The error seems to occur only when `jtagconfig` command is executed right after multiple download cables are connected

Troubleshooting Procedure

You need to wait for a while until your computer finishes the USB device enumeration after your Intel FPGA Download Cable is connected. You can use Device Manager on Windows or `lsusb` command on Linux to check if your Intel FPGA Download Cable is recognized on your computer.

For Windows: Open **Device Manager** and check if Intel FPGA Download Cable II (JTAG interface) under JTAG cables or Intel FPGA Download Cable under Universal Serial Bus controller is listed.

For Linux: Open a command shell, type `lsusb`, and check if the device with ID of `09fb:6001`, `09fb:6002`, `09fb:6003`, `09fb:6010`, or `09fb:6810` is listed.

B. Revision History

Table 11. Revision History for the Intel FPGA Download Cable User Guide

Document Version	Changes
2020.03.11	Updated Intel FPGA Download Cable Block Diagram in Block Diagram and Dimension on page 4
2019.10.23	Added the following sections: <ul style="list-style-type: none"> • Windows Troubleshooting Procedure for Intel FPGA Download Cable on page 13 • Troubleshooting Procedure for Error when scanning hardware - No Devices on page 15
2019.06.11	Updated <i>Block Diagram of the Intel FPGA Download Cable</i> to show correct position of Pin 1 in the section Block Diagram and Dimension on page 4
2019.04.12	<ul style="list-style-type: none"> • Corrected the unit in the <i>Recommended Operating Conditions</i> and <i>DC Operating Conditions for Intel FPGA Download Cable Rev. C</i> tables. • Added how to install USB drivers for Red Hat Enterprise systems.

Date	Version	Changes
October 2016	2016.10.31	<ul style="list-style-type: none"> • Changed instances of Quartus II to Quartus Prime. • Changed instances of USB-Blaster Download cable II to Intel FPGA Download Cable. • Updated document template.
August 2015	2015.08.20	<ul style="list-style-type: none"> • Removed <code>PROC_RST</code> signal which is not supported in USB-Blaster.
May 2015	2015.05.04	<ul style="list-style-type: none"> • Updated the document organization. • Added new devices in the following sections: Supported Devices and Host Systems and Power Requirements. • Updated the procedure on driver installation for Windows. • Revised the pin width of the female plug.
April 2009	2.5	<ul style="list-style-type: none"> • Updated "Supported Devices" section. • Updated "Software Requirements". • Deleted handnote in "Installing the USB-Blaster Driver on Windows Vista Systems". • Updated Table 2-1. • Added a handnote in "Circuit Board Header Connection". • Updated Table 2-5.
April 2008	2.4	<ul style="list-style-type: none"> • Added "Statement of China-RoHS Compliance". • Added Table 2-8. • Added "Installing the USB-Blaster Driver on Windows Vista Systems".
<i>continued...</i>		

Intel Corporation. All rights reserved. Intel, the Intel logo, and other Intel marks are trademarks of Intel Corporation or its subsidiaries. Intel warrants performance of its FPGA and semiconductor products to current specifications in accordance with Intel's standard warranty, but reserves the right to make changes to any products and services at any time without notice. Intel assumes no responsibility or liability arising out of the application or use of any information, product, or service described herein except as expressly agreed to in writing by Intel. Intel customers are advised to obtain the latest version of device specifications before relying on any published information and before placing orders for products or services.

*Other names and brands may be claimed as the property of others.

Date	Version	Changes
May 2007	2.3	<ul style="list-style-type: none">• Updated "Introduction".• Added warning note about USB-Blaster cable in "Hardware Setup" section.• Added information on Linux setup in "Installing the USB-Blaster Driver on Linux" section.• Added footnote note on driver information just before the "Setting Up the USB-Blaster Hardware in the Quartus II Software" section.• Updated USB-Blaster installation procedure for QII 6.1 (32-bit or 64-bit) in "Installing the USB-Blaster Driver on Windows 2000 and Windows XP Systems" section.
March 2007	2.2	<ul style="list-style-type: none">• Update to "Installing the USB-Blaster Driver on Windows 2000 and Windows XP Systems" section.
July 2006	2.1	Minor update to Chapter 2, USB-Blaster Specifications.
June 2006	2.0	<ul style="list-style-type: none">• Updated Figure 2-1, Table 2-1, and Table 2-7.• Added Table 2-6.
December 2004	1.2	Update to conditions in Table 2-2.
November 2004	1.1	Minor update.
July 2004	1.0	Initial release.

Looking for pricing, stock, or lifecycle information?

Click below to explore more details on WIN SOURCE:

 [View PL-USB2-BLASTER on WIN SOURCE](#)

 [Intel Information](#)

Optimize Your Supply Chain with WIN SOURCE Solutions

-  Global Sourcing Solution
-  Obsolete Management
-  Cost Control Management
-  Shortage Management
-  Alternative Solution
-  Excess Inventory Management