



**THE DATASHEET OF  
MAX38888ATD+**



Click [here](#) to ask about the production status of specific part numbers.

## MAX38888

## 2.5V to 5.0V, 0.5A/2.5A Reversible Buck/Boost Regulator for Backup Power Applications

### General Description

The MAX38888 is a storage capacitor or capacitor bank backup regulator designed to efficiently transfer power between a storage element and a system supply rail in reversible buck and boost operations using the same inductor.

When the main supply is present and above the minimum system supply voltage, the regulator operates in buck mode and charges the storage element at up to 500mA peak inductor current. Once the storage element is charged, the circuit draws only 2.5 $\mu$ A of current while it maintains the supercapacitor or other storage element in its ready state. When the main supply is removed, the regulator operates in boost mode and prevents the system from dropping below the minimum operating voltage, discharging the storage element at up to 2.5A peak inductor current.

The MAX38888 is externally programmable for minimum and maximum voltage of the storage element, such as supercapacitor, minimum system voltage, and maximum charge and discharge currents. The internal DC-DC converter requires only a 1 $\mu$ H inductor.

### Applications

- Handheld Industrial Equipment
- Portable Computers
- Portable Devices with a Removable Battery

### Benefits and Features

- 2.5V to 5V System Output Voltage
- 0.8V to 4.5V Cap Voltage Range
- Up to 2.5A Peak Inductor Discharge Current
- Programmable Voltage and Current Thresholds
- $\pm 2\%$  Threshold Accuracy
- Up to 95% Efficiency, Charge or Discharge
- 2.5 $\mu$ A Ready Quiescent Current
- Small Solution Size
  - 3mm x 3mm x 0.75mm TDFN Package

[Ordering Information](#) appears at end of data sheet.



## Absolute Maximum Ratings

CAP, EN, SYS, LX, BKUPB, RDY to GND .....	-0.3V to +6V	Operating Temperature Range .....	-40°C to +125°C
FBCH, FBCL to GND .....	-0.3V to CAP + 0.3V	Storage Temperature Range .....	-65°C to +150°C
FBS, ISET to GND .....	-0.3V to SYS + 0.3V	Maximum Junction Temperature .....	+150°C
PGND to GND .....	-0.3V to +0.3V	Lead Temperature (soldering, 10 seconds) .....	+300°C
Continuous Power Dissipation ( $T_A = +70^\circ\text{C}$ , TDFN, derate 24.4mW/°C above +70°C) .....	1951.2mW	LX RMS Current .....	$\pm 2.0\text{A}_{\text{RMS}}$
		Output Short-Circuit Duration .....	Continuous

Stresses beyond those listed under "Absolute Maximum Ratings" may cause permanent damage to the device. These are stress ratings only, and functional operation of the device at these or any other conditions beyond those indicated in the operational sections of the specifications is not implied. Exposure to absolute maximum rating conditions for extended periods may affect device reliability.

## Package Information

### TDFN

Package Code	T1433+2C
Outline Number	<a href="#">21-0137</a>
Land Pattern Number	<a href="#">90-0063</a>
<b>THERMAL RESISTANCE, FOUR-LAYER BOARD</b>	
Junction-to-Ambient ( $\theta_{JA}$ )	41°C/W
Junction-to-Case Thermal Resistance ( $\theta_{JC}$ )	8°C/W

For the latest package outline information and land patterns (footprints), go to [www.maximintegrated.com/packages](http://www.maximintegrated.com/packages). Note that a "+", "#", or "-" in the package code indicates RoHS status only. Package drawings may show a different suffix character, but the drawing pertains to the package regardless of RoHS status.

Package thermal resistances were obtained using the method described in JEDEC specification JESD51-7, using a four-layer board. For detailed information on package thermal considerations, refer to [www.maximintegrated.com/thermal-tutorial](http://www.maximintegrated.com/thermal-tutorial).

## Electrical Characteristics

( $V_{\text{SYS}} = 3.7\text{V}$ ,  $V_{\text{CAP}} = 2.7\text{V}$ ,  $T_J = -40^\circ\text{C}$  to  $+125^\circ\text{C}$  (typical values at  $T_J = +25^\circ\text{C}$ ), circuit of [Figure 1](#), unless otherwise specified.)

PARAMETER	SYMBOL	CONDITIONS	MIN	TYP	MAX	UNITS
SYS Voltage Range	$V_{\text{SYS}}$		2.5		5	V
CAP Voltage Range	$V_{\text{VSC}}$		0.8		4.5	V
SYS Shutdown Current	$I_{\text{SYS\_SD}}$	EN = 0V, $T_A = +25^\circ\text{C}$		0.01	1	$\mu\text{A}$
		EN = 0V		0.1		
SYS Charging Supply Current	$I_{\text{SYS\_CHG}}$	$V_{\text{FBS}} = 0.6\text{V}$ , $V_{\text{FBCH}} = V_{\text{FBCL}} = 0.485\text{V}$		1.5		mA
SYS Backup Supply Current	$I_{\text{SYS\_BUP}}$	$V_{\text{FBS}} = V_{\text{FBCH}} = V_{\text{FBCL}} = 0.515\text{V}$ , $T_A = +25^\circ\text{C}$		35	65	$\mu\text{A}$
		$V_{\text{FBS}} = V_{\text{FBCH}} = V_{\text{FBCL}} = 0.515\text{V}$		35		
SYS Ready Supply Current	$I_{\text{SYS\_RDY}}$	$V_{\text{FBS}} = 0.6\text{V}$ , $V_{\text{FBCH}} = V_{\text{FBCL}} = 0.515\text{V}$ , $T_A = +25^\circ\text{C}$		2.5	5	$\mu\text{A}$
		$V_{\text{FBS}} = 0.6\text{V}$ , $V_{\text{FBCH}} = V_{\text{FBCL}} = 0.515\text{V}$		2.5		
CAP Shutdown Current	$I_{\text{CAP\_SD}}$	EN = 0V, $T_A = +25^\circ\text{C}$		0.01	1	$\mu\text{A}$
		EN = 0V		0.1		

## Electrical Characteristics (continued)

(V<sub>SYS</sub> = 3.7V, V<sub>CAP</sub> = 2.7V, T<sub>J</sub> = -40°C to +125°C (typical values at T<sub>J</sub> = +25°C), circuit of [Figure 1](#), unless otherwise specified.)

PARAMETER	SYMBOL	CONDITIONS	MIN	TYP	MAX	UNITS
UVLO Threshold	V <sub>UVLOF</sub>	V <sub>SYS</sub> falling, 100mV typical hysteresis	1.7	1.8	1.9	V
FBS Backup Voltage	V <sub>FBS</sub>	FBS rising, when discharging stops	-2%	0.5	+2%	V
FBS Charging Threshold	V <sub>TH_FBSCHG</sub>	Above FBS backup voltage, when charging begins, 30mV typical hysteresis	25	60	95	mV
FBCH Threshold	V <sub>TH_FBCH</sub>	FBCH rising, when charging stops, 25mV typical hysteresis	-2%	0.5	+2%	V
FBCL Threshold	V <sub>TH_FBCL</sub>	FBCL falling, when preserve mode starts, 25mV typical hysteresis	-3.5%	0.475	+3.5%	V
EN Threshold	V <sub>IL</sub>	When LX stops switching, EN falling	225	600		mV
	V <sub>IH</sub>	EN rising		660	925	
ISET Resistor Range	R <sub>ISET</sub>	Guaranteed by LX peak current limits	20		100	kΩ
LX Peak Backup Current Limit (Note 1)	I <sub>DCHG</sub>	Circuit of <a href="#">Figure 1</a> , V <sub>CAP</sub> = 2V, V <sub>SYS</sub> = 2.9V, R <sub>ISET</sub> = 20kΩ	2.0	2.5	3.0	A
		Circuit of <a href="#">Figure 1</a> , V <sub>CAP</sub> = 2V, V <sub>SYS</sub> = 2.9V, R <sub>ISET</sub> = 100kΩ		0.50		
LX Peak Charge Current Limit (Note 1)	I <sub>CHG</sub>	Circuit of <a href="#">Figure 1</a> , V <sub>SYS</sub> = 3.7V, V <sub>CAP</sub> = 2V, R <sub>ISET</sub> = 20kΩ	400	500	600	mA
		Circuit of <a href="#">Figure 1</a> , V <sub>SYS</sub> = 3.7V, V <sub>CAP</sub> = 2V, R <sub>ISET</sub> = 100kΩ		100		
FBS/FBCH/FBCL Input Bias Current	I <sub>FBS/FBCH/FBCL</sub>	V <sub>FBS/FBCH/FBCL</sub> = 0.5V, T <sub>A</sub> = +25°C	-0.1	0.001	0.1	μA
		V <sub>FBS/FBCH/FBCL</sub> = 0.5V		0.01		
EN Input Leakage Current	I <sub>EN</sub>	0V < V <sub>EN</sub> < 5.5V, T <sub>A</sub> = +25°C	-0.1	0.001	0.1	μA
		0V < V <sub>EN</sub> < 5.5V		0.01		
LX Switching Frequency	f <sub>SW</sub>	Delivering maximum current from CAP		2		MHz
LX Low-Side FET Resistance	R <sub>LOW</sub>	V <sub>SYS</sub> = 3V, LX switched to GND		50	100	mΩ
LX High-Side FET Resistance	R <sub>HIGH</sub>	V <sub>SYS</sub> = 3V, LX switched to SYS		80	160	mΩ
LX Leakage Current	I <sub>LX_LKG</sub>	V <sub>EN</sub> = 0V, V <sub>SYS</sub> = 5V, V <sub>LX</sub> = 0V/5V, T <sub>A</sub> = +25°C	-1		1	μA
		V <sub>EN</sub> = 0V, V <sub>SYS</sub> = 5V, V <sub>LX</sub> = 0V/5V		0.1		
Maximum On-Time	t <sub>ON</sub>	Backup mode, V <sub>FBS</sub> = 0.485V	320	400	480	ns
Minimum Off-Time	t <sub>OFF</sub>	Backup mode, V <sub>FBS</sub> = 0.485V	80	100	120	ns
Overtemperature Lockout Threshold	T <sub>OTLO</sub>	T <sub>J</sub> rising, 15°C typical hysteresis		165		°C
High-Side FET Zero-Crossing (Note 1)	I <sub>ZXP</sub>	Circuit of <a href="#">Figure 1</a> , V <sub>CAP</sub> = 2V, V <sub>SYS</sub> = 2.9V	25	50	75	mA
Low-Side FET Zero-Crossing (Note 1)	I <sub>ZXN</sub>	Circuit of <a href="#">Figure 1</a> , V <sub>SYS</sub> = 3.7V, V <sub>CAP</sub> = 2V	25	50	75	mA
BKUPB Leakage Current	I <sub>BKUPB</sub>	V <sub>EN</sub> = 0V, V <sub>BKUPB</sub> = 5V, T <sub>A</sub> = +25°C	-1		1	μA
		V <sub>EN</sub> = 0V, V <sub>BKUPB</sub> = 5V		0.1		

**Electrical Characteristics (continued)**(V<sub>SYS</sub> = 3.7V, V<sub>CAP</sub> = 2.7V, T<sub>J</sub> = -40°C to +125°C (typical values at T<sub>J</sub> = +25°C), circuit of [Figure 1](#), unless otherwise specified.)

PARAMETER	SYMBOL	CONDITIONS	MIN	TYP	MAX	UNITS
BKUPB Output Voltage Low	V <sub>BKUPB_L</sub>	V <sub>FBS</sub> = 0.48V, V <sub>FBCH</sub> = V <sub>FBCL</sub> = 0.515V, I <sub>SINK</sub> = 2mA			0.4	V
RDY Leakage Current	I <sub>RDY</sub>	V <sub>FBCH</sub> = 0.54V, V <sub>RDY</sub> = 5V, T <sub>A</sub> = 25°C	-1		1	μA
		V <sub>FBCH</sub> = 0.54V, V <sub>RDY</sub> = 5V		0.1		
RDY Output Voltage Low	V <sub>RDY_L</sub>	V <sub>EN</sub> = 0V, I <sub>SINK</sub> = 2mA			0.4	V

**Note 1:** DC measurement, actual zero-crossing, and peak current accuracy in the circuit will be affected by the propagation delay time.

Typical Operating Characteristics

( $V_{SYS} = 3.6V$ ,  $V_{CAP} = 2.0V$ ,  $C1 = 22\mu F$ ,  $C2 = 22\mu F$ ,  $T_A = +25^\circ C$ , unless otherwise noted.)

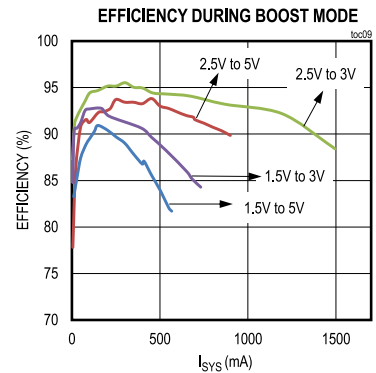
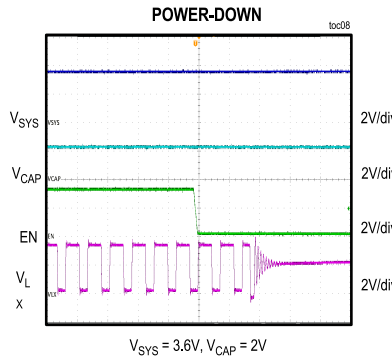
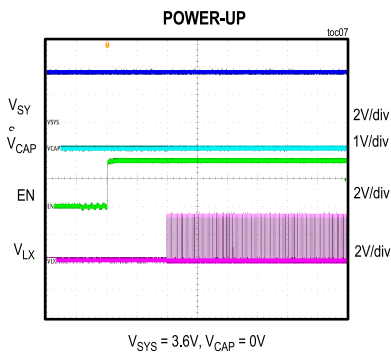
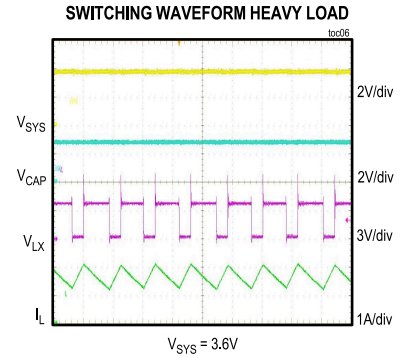
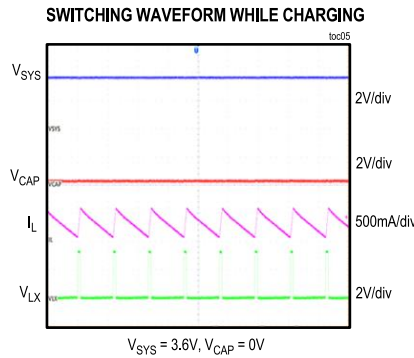
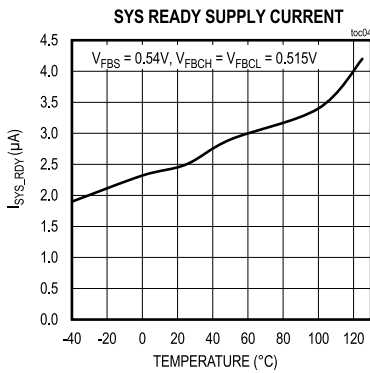
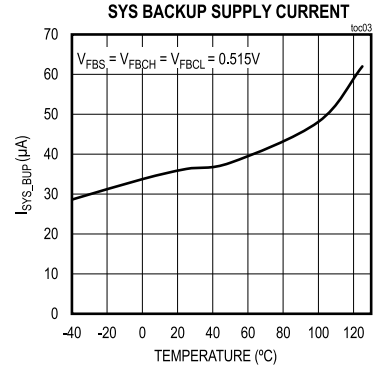
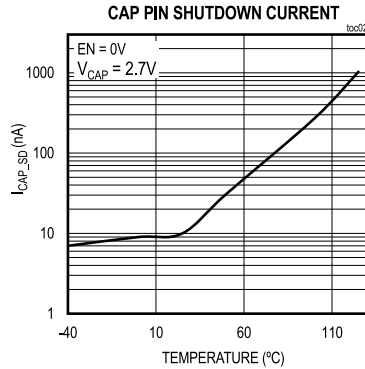
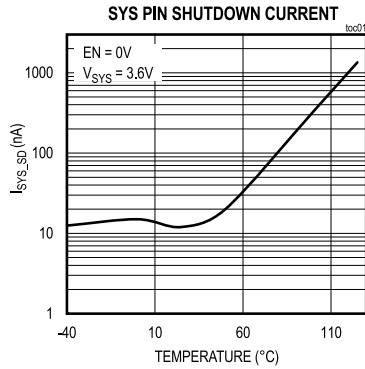

Typical Operating Characteristics (continued)

( $V_{SYS} = 3.6V$ ,  $V_{CAP} = 2.0V$ ,  $C1 = 22\mu F$ ,  $C2 = 22\mu F$ ,  $T_A = +25^\circ C$ , unless otherwise noted.)

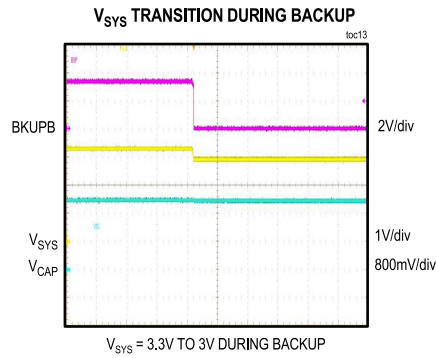
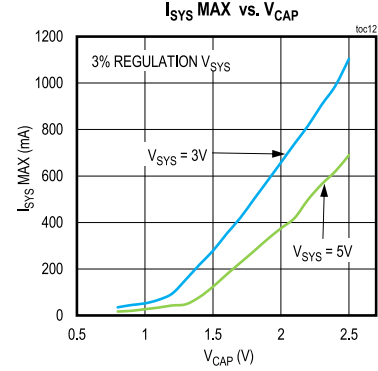
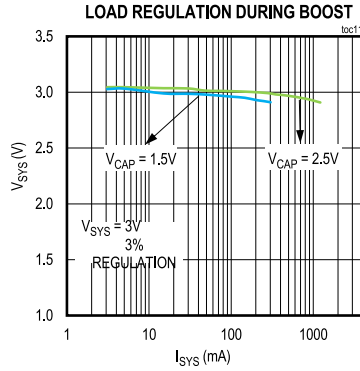
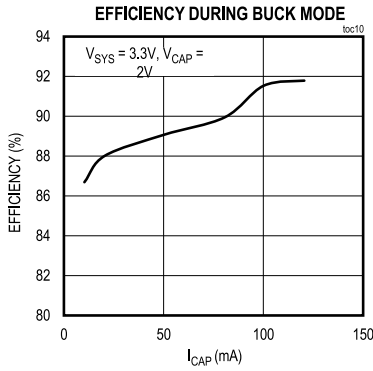

Pin Configuration

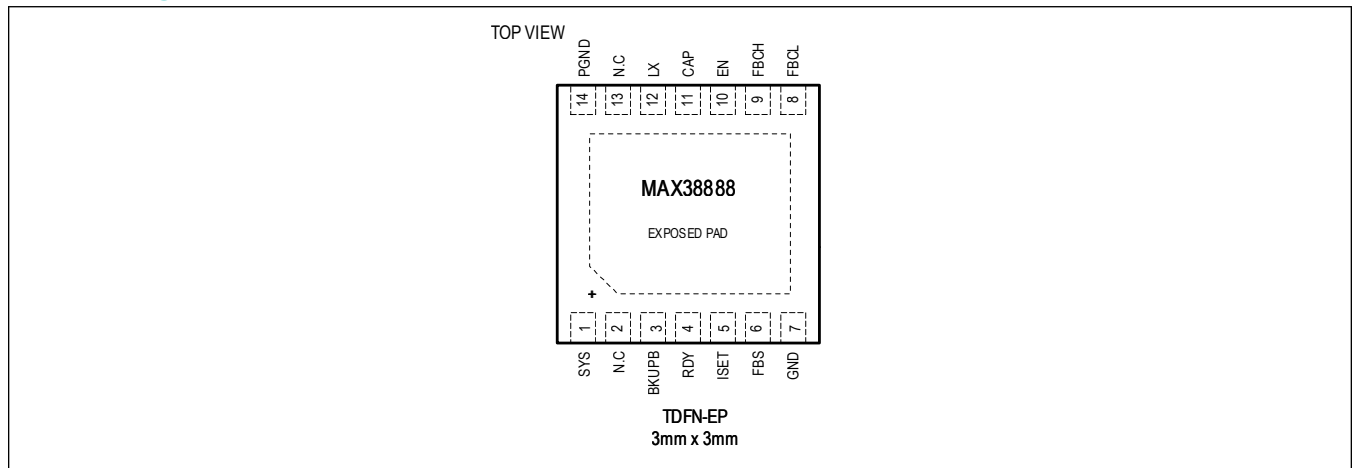

## Pin Description

PIN	NAME	FUNCTION
1	SYS	System Supply Rail. Connect to a system supply rail or removable battery between 2.5V and 5V and bypass with a 22 $\mu$ F capacitor to GND.
2	NC	No Connect.
3	BKUPB	Open-Drain Backup Indicator. BKUPB is held low when the part is in backup mode (i.e., when FBS < 0.5V and FBCL > 0.5V). BKUPB is released high when FBCL < 0.475V or FBS > 0.56V. Connect to an external pullup resistor.
4	RDY	Open-Drain Supercap Ready Indicator. RDY goes high when the supercapacitor is fully charged (i.e., FBCH > 0.5V). RDY is pulled low when FBCL < 0.475V. Connect to an external pullup resistor.
5	ISET	Charge/Discharge Current Input. The peak discharge current is set by $50kV/R_{ISET}$ while the peak charging current is 1/5 the discharging current.
6	FBS	SYS Feedback. Connect to the center point of a resistor divider from SYS to GND. SYS will boost to $0.5V \times (1 + R_{STop}/R_{SBot})$ when $V_{FBS} < 0.5V$ .
7	GND	Analog Ground.
8	FBCL	CAP Feedback. Connect to the upper point of a resistor divider from CAP to GND. Part enters preserve mode when $V_{FBCL} < 0.475V$ .
9	FBCH	CAP Feedback. Connect to the lower point of a resistor divider from CAP to GND. CAP will charge to $0.5V \times (1 + R_{CTop}/R_{CBot})$ when $V_{FBS} > 0.56V$ .
10	EN	Enable Input. Force this pin high to enable the regulator or force pin low to disable the part and enter shutdown. If not driven, tie it to the SYS rail.
11	CAP	Super Cap. Connect to a supercapacitor rated between 0.8V to 5V with a maximum voltage less than $V_{SYS}$ .
12	LX	Inductor Switching Node. Connect a 1.0 $\mu$ H to 4.7 $\mu$ H inductor from LX to CAP.
13	NC	No Connect.
14, EP	PGND	Power Ground.

Functional Diagram

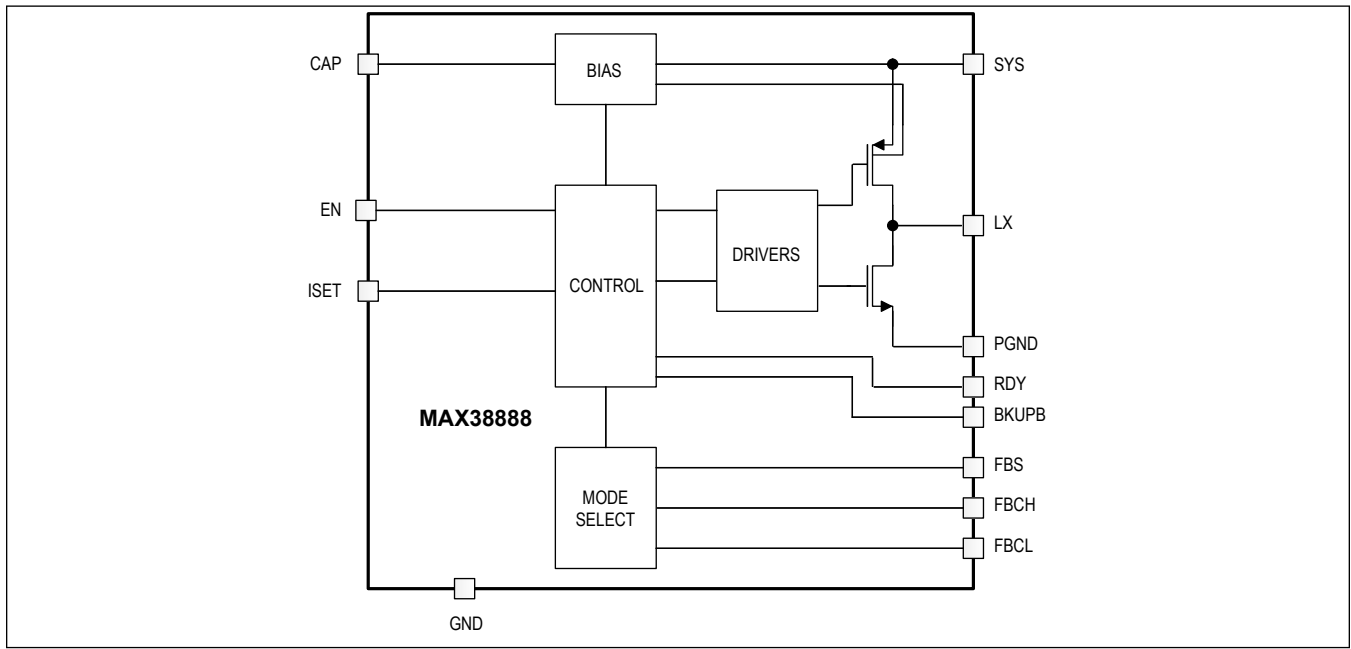

### Detailed Description

The MAX38888 is a flexible storage capacitor or capacitor bank backup regulator efficiently transferring power between a storage element and a system supply rail.

When the main supply is present and its voltage above the minimum system supply voltage, the regulator operates in the charging mode of operation and charges the storage element at up to 500mA peak inductor current. Once the storage element is charged, the RDY flag will assert and the circuit will draw only 2.5µA of current while maintaining the storage element in its ready state.

When the main supply is removed, the regulator prevents the system from dropping below the minimum operating voltage, boosting  $V_{SYS}$  by discharging the storage element at up to 2.5A peak inductor current. During this backup mode of operation, the MAX38888 utilizes a fixed on-time, current-limited, pulse-frequency-modulation (PFM) control scheme. Once MAX38888 is in the backup mode, the BKUPB flag is asserted. When  $V_{SYS}$  is applied for the first time, ensure that the supercapacitor is charged to 2.7V to activate backup mode.

The external pins allow a wide range of system and storage element, such as supercapacitor voltage settings, as well as charging and discharging peak inductor current settings.

The MAX38888 implements a True Shutdown™ feature, disconnecting  $V_{SYS}$  from  $V_{CAP}$  as well as protecting against a SYS short or if  $V_{CAP} > V_{SYS}$ .

### Application Circuit

The typical application of the MAX38888 is shown in [Figure 1](#).

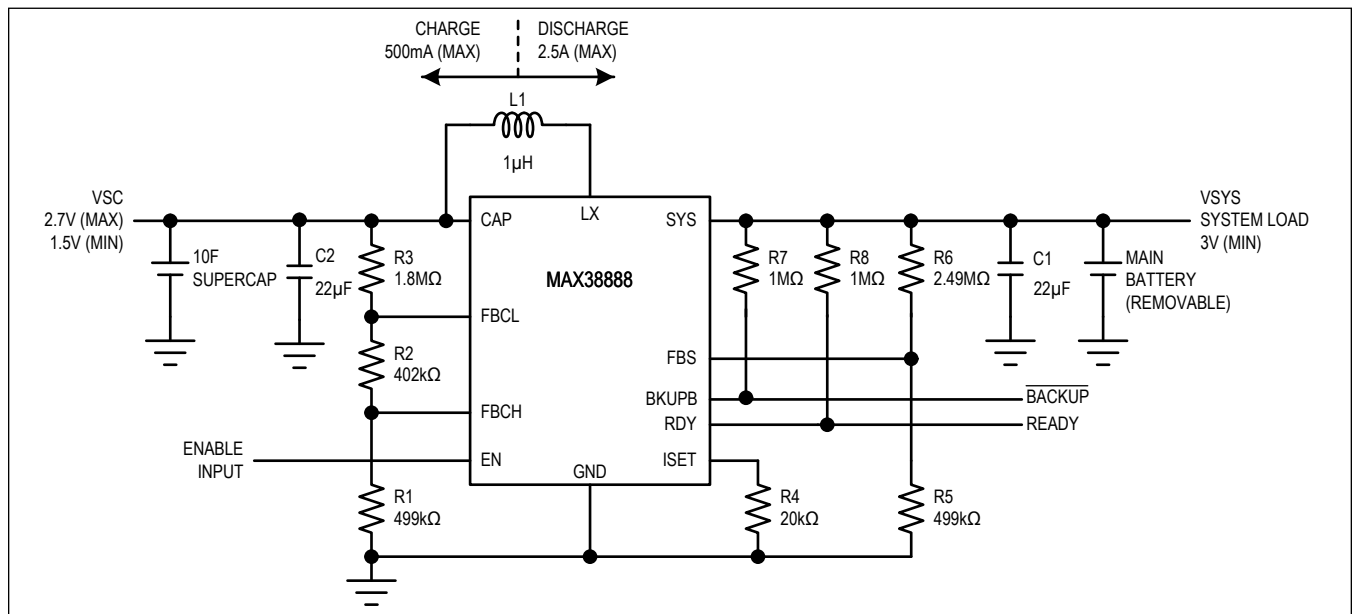

Figure 1. Typical Application

### Supercapacitor Voltage Configuration

The maximum supercapacitor voltage is set using a resistor-divider from CAP to FBCH to GND. The recommended value for R1 is 499kΩ. Because resistor tolerance will have direct effect on voltage accuracy, these resistors should have 1% accuracy or better.

$$R2 + R3 = R1 \times ((V_{CAPMAX} / 0.5) - 1)$$

$V_{CAP}$  halts charging when  $V_{FBCH}$  reaches 0.5V. The maximum supercapacitor voltage is where the supercapacitor will remain after it is completely charged and ready for backup.

The minimum supercapacitor discharge voltage is set using a resistor-divider from CAP to FBCL to GND.

$$R3 = (R1 + R2) \times ((V_{CAPMIN} / 0.5) - 1)$$

FBCL prevents the supercapacitor from further discharge when  $V_{FBCL}$  reaches 0.475V during a backup event in order to preserve the remaining capacity for keeping alive a real-time clock, memory, or other low-level function. In this preserve mode, the IC disconnects all circuitry from the supercapacitor and draws 2.5 $\mu$ A current from it.

In applications where SYS voltage needs to be boosted to higher levels, selecting  $V_{CAP}$  min has to take into account duty cycle limitation of the boosting phase, which is 80%. The MAX38888 detects when  $V_{SYS}$  falls below  $V_{CAP}$ . The device will not enable if  $V_{SYS}$  is below  $V_{CAP}$ . Raising  $V_{SYS}$  above the backup threshold re-initiates charging and backup.

### System Voltage Configuration

The minimum system voltage is set using a resistor-divider from SYS to FBS to GND. The recommended value for R5 is 499k $\Omega$ . Because resistor tolerance will have direct effect on voltage accuracy, these resistors should have 1% accuracy or better.

$$R6 = R5 \times ((V_{SYSMIN} / 0.5) - 1)$$

When  $V_{FBS}$  is above 0.56V, the DC-DC regulator will draw power from the SYS pin to charge the supercapacitor to the maximum voltage set by FBCH and be ready for backup. When the main battery is removed,  $V_{FBS}$  drops to 0.5V and the SYS pin is regulated to the programmed minimum voltage with up to 2A of CAP current.

### Charge/Discharge Current Configuration

The peak inductor discharge current is set by placing a resistor from ISET to GND. The values of  $R_{ISET}$  resistor is calculated by following formula:

$$I_{DISCHARGE} = 2.5A \times (20k\Omega / R_{ISET})$$

The supercapacitor charging current is internally set to 1/5 of the discharge current.

$$I_{CHARGE} = 0.5A \times (20k\Omega / R_{ISET})$$

the value of  $R_{ISET}$  between 20k $\Omega$  and 100k $\Omega$  is recommended to ensure accurate current compliance.

### System Waveforms

The waveforms in [Figure 2](#) represent system behavior of the MAX38888 in the [Typical Application Circuit](#).

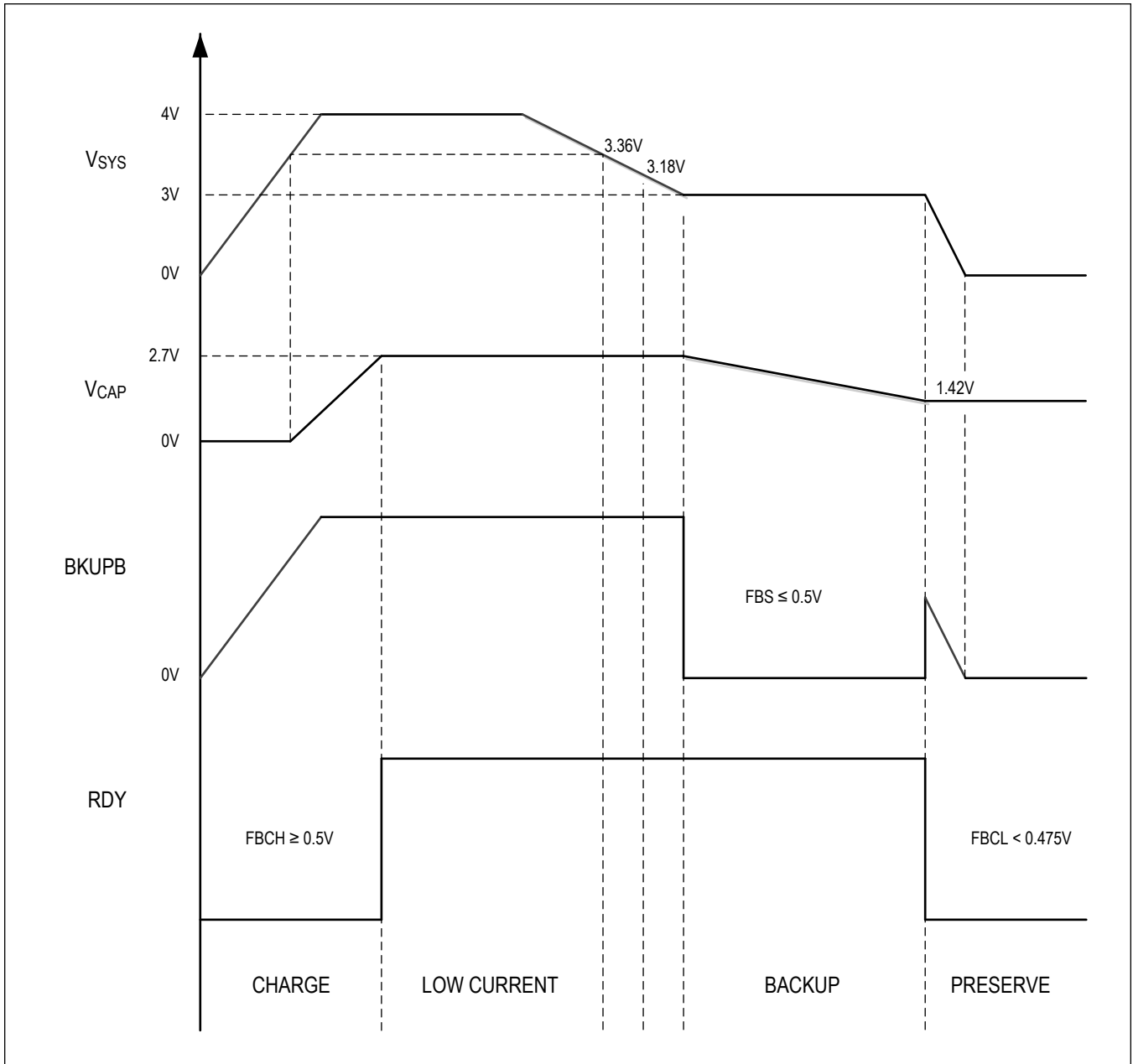

Figure 2. System Waveforms

## Applications Information

### Capacitor Selection

Capacitors at the SYS and CAP pins reduce current peaks and increase efficiency. Ceramic capacitors are recommended because they have the lowest equivalent series resistance (ESR), smallest size, and lowest cost. Choose an acceptable dielectric such as X5R or X7R. Due to the ceramic capacitors' capacitance derating with DC bias, standard 22 $\mu$ F ceramic capacitors are recommended at both pins for most applications.

### Supercapacitor Selection

When the power source supplying the  $V_{SYS}$  voltage is removed, power to the output is provided by the MAX38888 operating in the back-up or boost mode of operation using the supercapacitor as its source. In order to ensure the supply voltage stays in regulation, the amount of power the supercapacitor can deliver at its minimal voltage should be greater than that required by the system. The MAX38888 will present a constant power load to the supercapacitor where smaller current will be pulled out of the supercapacitor near its maximum  $V_{CAP}$  voltage. However, current drawn from the supercapacitor will increase as it discharges to maintain constant power at the load. The amount of energy required in the backup mode will be the product of the constant backup power and time defined as backup time,  $t_{BACKUP}$ .

The amount of energy available in the supercapacitor is calculated using the following formula:

$$E = 1/2 \times C_{SCAP} \times (V_{CAPMAX}^2 - V_{CAPMIN}^2) (J)$$

The amount of energy required to complete the backup equals:

$$E = V_{SYS} \times I_{SYS} \times t_{BACKUP} (J)$$

where,  $I_{SYS}$  will be the system load during backup.

Since the energy required at the system side during the backup event comes from the available energy in the supercapacitor, assuming conversion efficiency  $\eta$  and given  $t_{BACKUP}$ , the required  $C_{SCAP}$  will be determined by the following equation:

$$C_{SCAP} = (2 \times V_{SYS} \times I_{SYS} \times t_{BACKUP}) / [(V_{CAPMAX}^2 - V_{CAPMIN}^2) \times \eta] (F)$$

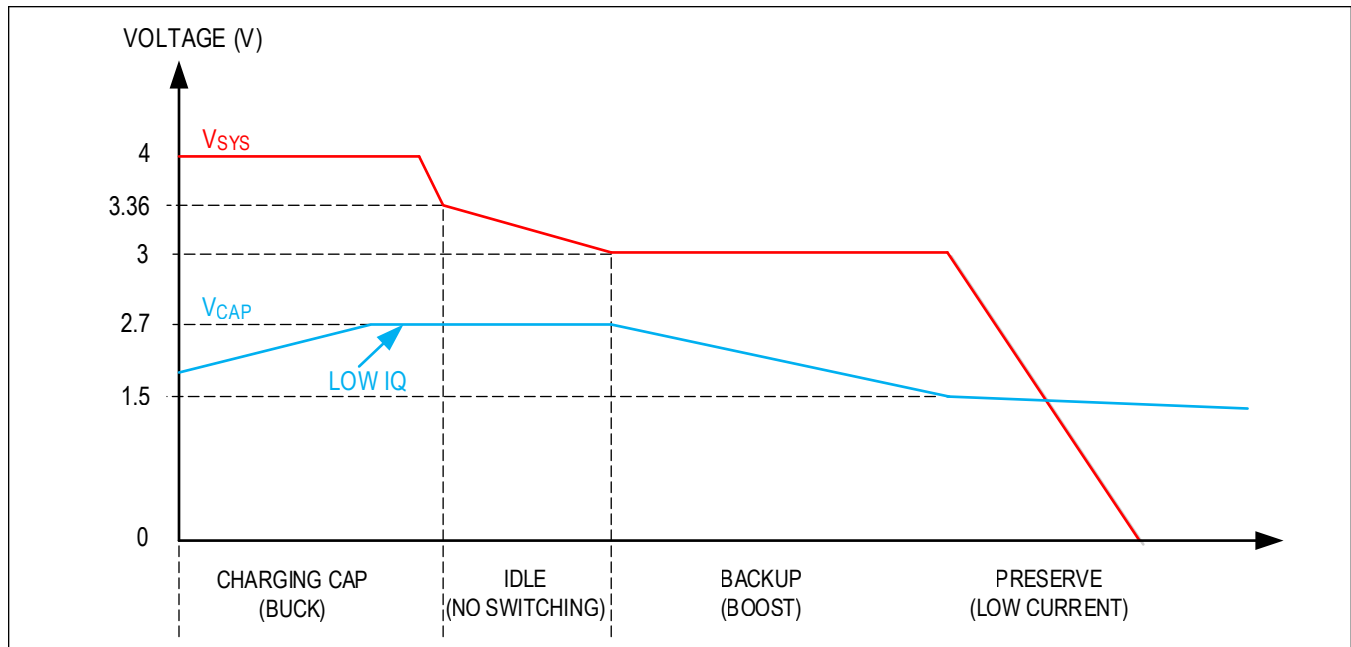

Figure 3. Charging/Discharging Waveforms

For example, in [Figure 1](#) (Application Circuit), the minimum value of the supercapacitor required for 1s backup time, assuming a 200mA system load and average efficiency of 93%, will be:

$$C_{SCAP} \geq (2 \times 3.0V \times 0.2A \times 1s) / [(2.7V)^2 - (1.5V)^2] \times 0.93 = 256mF$$

### Inductor Selection

The MAX38888 works with a 1 $\mu$ H inductor in most applications. In applications where lower peak currents are desired, larger inductance may be used in order to reduce the ripple. The recommended inductance range is from 1 $\mu$ H to 4.7 $\mu$ H. Select 4.7 $\mu$ H for higher R<sub>ISET</sub> value (100k $\Omega$ ). 1 $\mu$ H is not supported for a 100k $\Omega$  R<sub>ISET</sub> value.

### Status Flags

The MAX38888 has two dedicated pins to report the device status to the host processor. The ready output (RDY) will be high when the supercapacitor is fully charged (i.e., FBCH > 0.5V). RDY is pulled low when FBCL < 0.475V. The other status flag is the Backup Output (BKUPB), which will be held low when the part is in the backup mode (i.e., when FBS < 0.5V and FBCL > 0.5V). BKUPB is released high when FBCL < 0.475V or FBS > 0.56V. Both output pins are open-drain type and require external pullup resistors. Recommended values for the pullup resistors are 1M $\Omega$ . The pins should be pulled up to the SYS rail.

### Enabling Device

The MAX38888 has a dedicated enable pin. The pin can either be driven by a digital signal, pulled up, or strapped to the SYS rail.

### PCB Layout Guidelines

Minimize trace lengths to reduce parasitic capacitance, inductance and resistance, and radiated noise. Keep the main power path from SYS, LX, CAP, and PGND as tight and short as possible. Minimize the surface area used for LX since this is the noisiest node. The trace between the feedback resistor-dividers should be as short as possible and should be isolated from the noisy power path. Refer to the EV kit layout for best practices.

MAX38888

## 2.5V to 5.0V, 0.5A/2.5A Reversible Buck/Boost Regulator for Backup Power Applications

The PCB layout is important for robust thermal design. The junction-to-ambient thermal resistance of the package greatly depends on the PCB type, layout, and pad connections. Using thick PCB copper and having the SYS, LX, CAP, and PGND copper pours will enhance the thermal performance. The TDFN package has a large thermal pad under the package, which creates excellent thermal path to PCB. This pad is electrically connected to PGND. Its PCB pad should have multiple thermal vias connecting the pad to the internal PGND plane. Thermal vias should either be capped or have small diameter to minimize solder wicking and voids.

### Ordering Information

PART NUMBER	TEMP RANGE	PIN-PACKAGE	FEATURES
MAX38888ATD+	-40°C to +125°C	14 TDFN	Enable Input, Selectable Voltages and Currents

+ Denotes a lead(Pb)-free/RoHS-compliant package.

T Denotes tape-and-reel.

MAX38888

2.5V to 5.0V, 0.5A/2.5A Reversible Buck/Boost  
Regulator for Backup Power Applications

Revision History

REVISION NUMBER	REVISION DATE	DESCRIPTION	PAGES CHANGED
0	6/18	Initial release	—
1	7/18	Updated <i>General Description</i> and <i>Benefits and Features</i>	1
2	10/18	Updated <i>General Description</i> , <i>Benefits and Features</i> , <i>Electrical Characteristics</i> table, <i>Typical Operating Characteristics</i> , <i>Detailed Description</i>	1, 3–6, 9–12
3	7/19	Updated <i>Supercapacitor Voltage Configuration</i> section	9
4	12/19	Updated <i>Enabling Device</i> section	12
5	8/20	Updated <i>Detailed Description</i>	10

For pricing, delivery, and ordering information, please visit Maxim Integrated's online storefront at <https://www.maximintegrated.com/en/storefront/storefront.html>.

Maxim Integrated cannot assume responsibility for use of any circuitry other than circuitry entirely embodied in a Maxim Integrated product. No circuit patent licenses are implied. Maxim Integrated reserves the right to change the circuitry and specifications without notice at any time. The parametric values (min and max limits) shown in the *Electrical Characteristics* table are guaranteed. Other parametric values quoted in this data sheet are provided for guidance.

## Looking for pricing, stock, or lifecycle information?

Click below to explore more details on WIN SOURCE:

 [View MAX38888ATD+ on WIN SOURCE](#)

 [Analog Devices Inc. Information](#)

## Optimize Your Supply Chain with WIN SOURCE Solutions

-  Global Sourcing Solution
-  Obsolete Management
-  Cost Control Management
-  Shortage Management
-  Alternative Solution
-  Excess Inventory Management