



**THE DATASHEET OF
MP6619GQ-P**



DESCRIPTION

The MP6619 is an H-bridge motor driver that operates from a supply voltage up to 28V and delivers a motor current up to 5A. The MP6619 is ideally suited to drive a brushed DC motor.

The MP6619 also has cycle-by-cycle current limiting.

Full protection features include over-current protection (OCP), input over-voltage protection (OVP), under-voltage lockout (UVLO), and thermal shutdown.

The MP6619 is available in a QFN-19 (3mmx3mm) package.

FEATURES

- Wide 5.4V to 28V Operating Input Range
- Up to 5A Peak Output Current
- Internal H-Bridge Driver
- Cycle-by-Cycle Current Limiting
- 65mΩ $R_{DS(ON)}$ for Each Half-Bridge MOSFET
- 100% Duty Cycle Operation of H-Bridge
- 1μA Shutdown Mode
- Output Short-Circuit Protection (SCP)
- Input Over-Voltage Protection (OVP)
- Under-Voltage Lockout (UVLO)
- Over-Temperature Shutdown
- Fault Indication Output
- Available in a QFN-19 (3mmx3mm) Package

APPLICATIONS

- DC Motors
- Solenoid/Actuators

All MPS parts are lead-free, halogen-free, and adhere to the RoHS directive. For MPS green status, please visit the MPS website under Quality Assurance. "MPS", the MPS logo, and "Simple, Easy Solutions" are trademarks of Monolithic Power Systems, Inc. or its subsidiaries.

TYPICAL APPLICATION

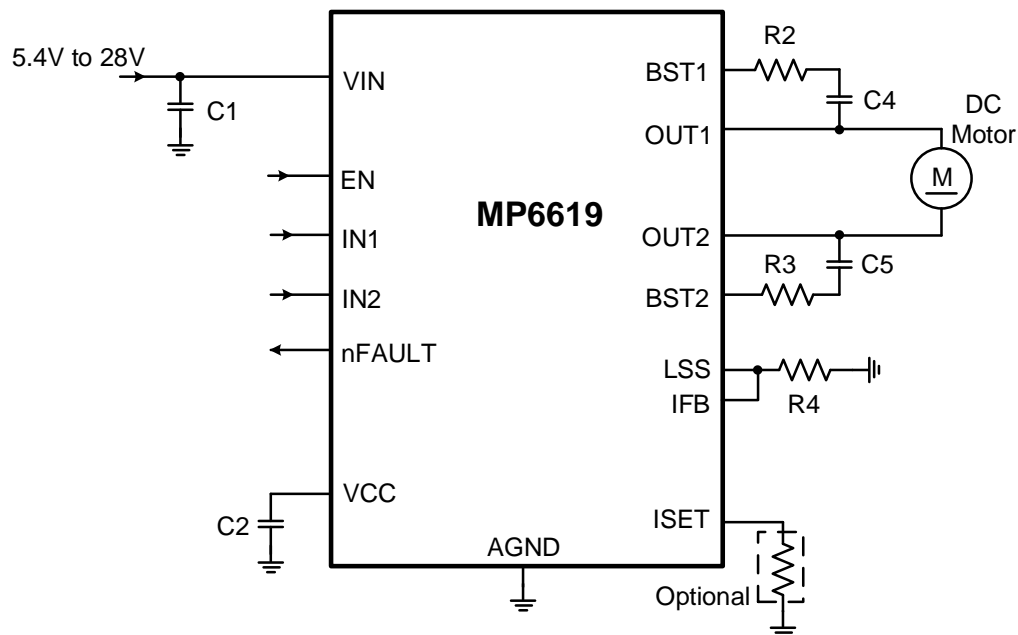

ORDERING INFORMATION

Part Number*	Package	Top Marking	MSL Rating
MP6619GQ	QFN-19 (3mmx3mm)	See Below	1

* For Tape & Reel, add suffix -Z (e.g. MP6619GQ-Z).

TOP MARKING

BJXY
LLL

Y: Year code
 BJX: product code
 LLL: Lot number

PACKAGE REFERENCE

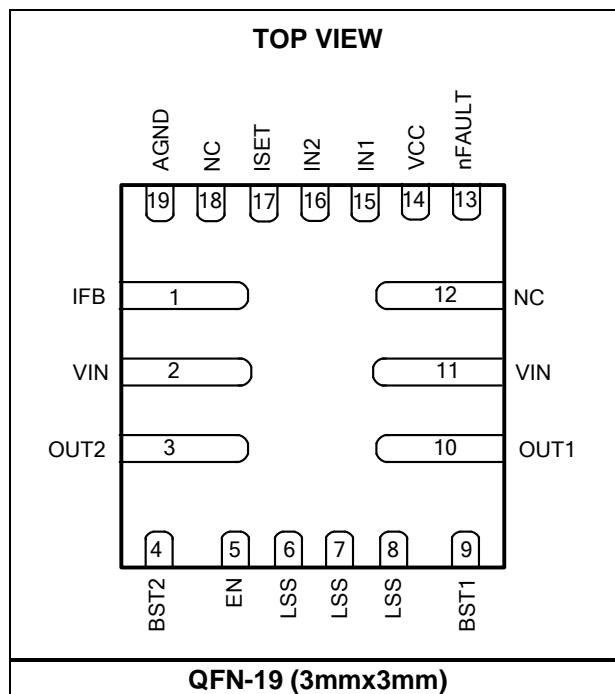

PIN FUNCTIONS

Pin #	Name	Description
1	IFB	Current-sense signal feedback. Connect the IFB and LSS pins together.
2, 11	VIN	Input supply.
3	OUT2	Output terminal 2.
4	BST2	Bootstrap pin for the OUT2 high-side MOSFET (HS-FET) gate driver. Connect a capacitor between the BST2 and OUT2 pins.
5	EN	IC enable.
6, 7, 8	LSS	Low-side source connection. For current sense, connect a current-sense resistor between the LSS pin and power ground.
9	BST1	Bootstrap pin for the OUT1 HS-FET gate driver. Connect a capacitor between BST1 and OUT1.
10	OUT1	Output terminal 1.
12, 18	NC	No connection. Float this pin or connect it to AGND.
13	nFAULT	Fault indication output. nFAULT is active low for fault conditions.
14	VCC	5V LDO output for internal driver and logic.
15	IN1	Output 1 control input. IN1 is pulled down internally.
16	IN2	Output 2 control input. IN2 is pulled down internally.
17	ISET	Current trip voltage setting. Connect a resistor to GND from the ISET pin.
19	AGND	Ground for internal logic.

ABSOLUTE MAXIMUM RATINGS ⁽¹⁾

Supply voltage (V_{IN})	36V
V_{OUTX}	-0.3V to $V_{IN} + 0.3V$
V_{BST1}	$V_{OUT1} + 6V$
V_{BST2}	$V_{OUT2} + 6V$
LSS	-0.3V to +0.6V
All other pins	-0.3V to +6V
Continuous power dissipation ($T_A = 25^\circ C$) ⁽²⁾	
QFN-19 (3mmx3mm)	2.5W
Junction temperature	150°C
Lead temperature	260°C
Storage temperature	-65°C to +150°C

ESD Ratings

Human body model (HBM)	±2kV
Charged device model (CDM)	±1.25kV

Recommended Operating Conditions ⁽³⁾

Supply voltage (V_{IN})	5.4V to 28V
Operating junction temp (T_J)	-40°C to +125°C

Thermal Resistance ⁽⁴⁾	θ_{JA}	θ_{JC}
QFN-19 (3mmx3mm)	50	12

Notes:

- Exceeding these ratings may damage the device.
- The maximum allowable power dissipation is a function of the maximum junction temperature T_J (MAX), the junction-to-ambient thermal resistance θ_{JA} , and the ambient temperature T_A . The maximum allowable continuous power dissipation at any ambient temperature is calculated by P_D (MAX) = $(T_J$ (MAX) - T_A) / θ_{JA} . Exceeding the maximum allowable power dissipation can produce an excessive die temperature, which can cause the regulator to go into thermal shutdown. Internal thermal shutdown circuitry protects the device from permanent damage.
- The device is not guaranteed to function outside of its operation conditions.
- Measured on a JESD51-7, 4-layer PCB.

ELECTRICAL CHARACTERISTICS

$V_{IN} = 24V$, $T_A = 25^{\circ}C$, unless otherwise noted.

Parameters	Symbol	Condition	Min	Typ	Max	Units
Supply Voltage						
VIN operating range	V_{IN}		5.4		28	V
Turn-on threshold	V_{IN_ON}	VIN rising edge		5.1	5.35	V
Turn-on hysteretic voltage	V_{IN_HY}			0.3		V
IC Supply						
Shutdown current	I_{IN_SD}	EN = 0			1	μA
Quiescent current	I_{IN_SBY}	EN = 1, no load current		1.6	2.2	mA
VCC regulator voltage	V_{VCC}		4.5	5	5.5	V
VCC regulator dropout voltage		20mA load		100		mV
Logic						
Logic high threshold					1.5	V
Logic low threshold			0.4			V
IC start-up delay	t_{DELAY}	EN active to switching		230	350	μs
Current Control						
Current trip voltage	V_{ITRIP}	$V_{ITRIP} = 200mV$	180	200	220	mV
		$V_{ITRIP} = 100mV$	85	100	115	mV
Off time	t_{ITRIP}	After ITRIP		1		ms
Power MOSFET						
High-side MOSFET (HS-FET) on resistance			42	65	93	m Ω
Low-side MOSFET (LS-FET) on resistance			42	65	93	m Ω
Minimum on time				200		ns
Bootstrap for High-Side Driver						
Forward voltage for BST charge				0.5		V
BST UVLO		Rising edge		2		V
Protection						
Over-current (OC) retry time	t_{OCP}			1		ms
OC threshold	I_{OCP}			10		A
Input over-voltage (OV) threshold	V_{INOVP}		32.2	34	35.5	V
Thermal shutdown ⁽⁵⁾				150		$^{\circ}C$
Thermal shutdown hysteresis ⁽⁵⁾				20		$^{\circ}C$

Note:

5) Guaranteed by design.

TYPICAL PERFORMANCE CHARACTERISTICS

$V_{IN} = 24V$, $T_A = 25^{\circ}C$, unless otherwise noted.

Normal Operation

$V_{IN} = 24V$, $IN1 = 20kHz / 50\%$, $IN2 = low$,
load = $5\Omega + 700\mu H$

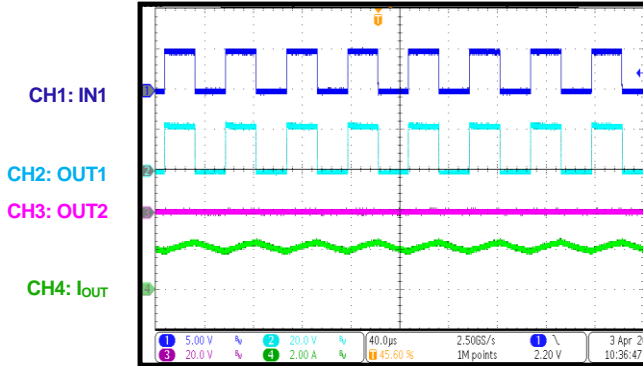

Normal Operation

$V_{IN} = 24V$, $IN1 = 20kHz / 50\%$, $IN2 = high$,
load = $5\Omega + 700\mu H$

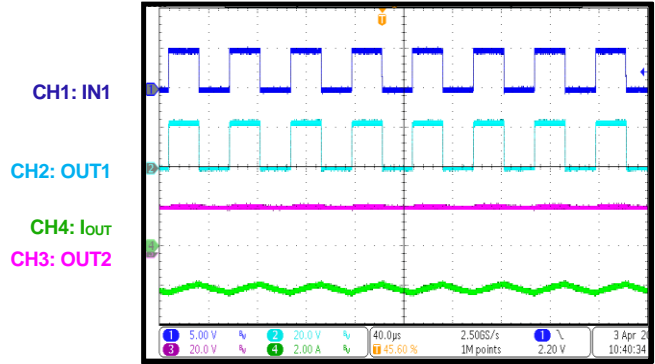

Start-Up through VIN

$V_{IN} = 24V$, $IN1 = 20kHz / 50\%$, $IN2 = low$,
load = $5\Omega + 700\mu H$

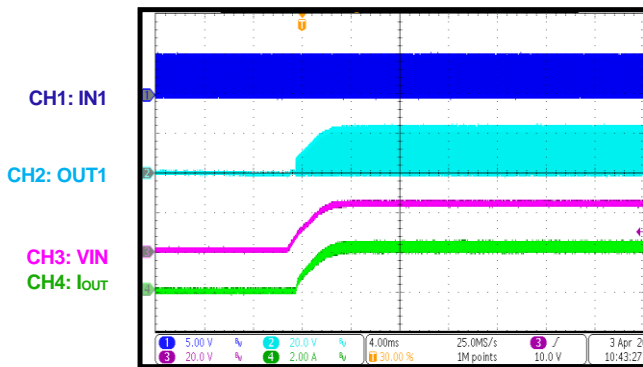

Start-Up through VIN

$V_{IN} = 24V$, $IN1 = 20kHz / 50\%$, $IN2 = high$,
load = $5\Omega + 700\mu H$

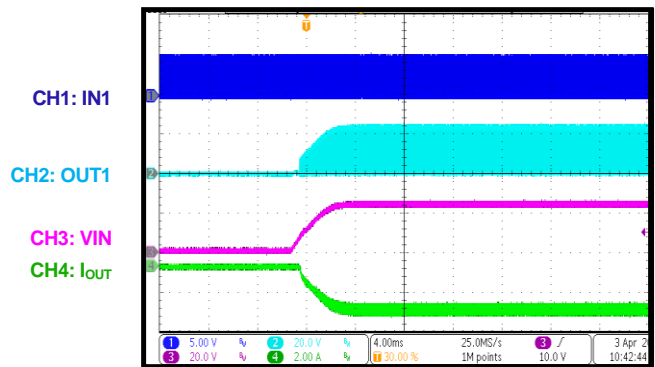

Shutdown through VIN

$V_{IN} = 24V$, $IN1 = 20kHz / 50\%$, $IN2 = low$,
load = $5\Omega + 700\mu H$

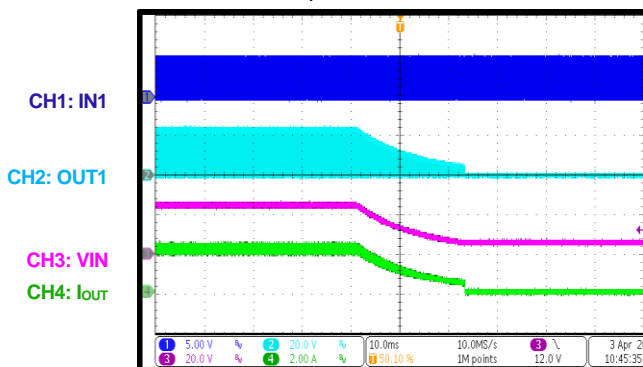

Shutdown through VIN

$V_{IN} = 24V$, $IN1 = 20kHz / 50\%$, $IN2 = high$,
load = $5\Omega + 700\mu H$

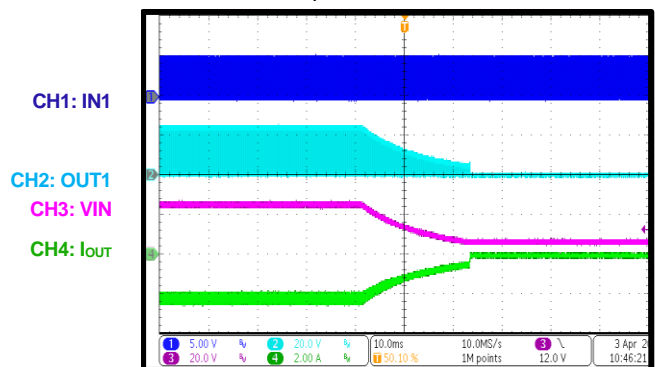

TYPICAL PERFORMANCE CHARACTERISTICS (continued)
 $V_{IN} = 24V$, $T_A = 25^\circ C$, unless otherwise noted.

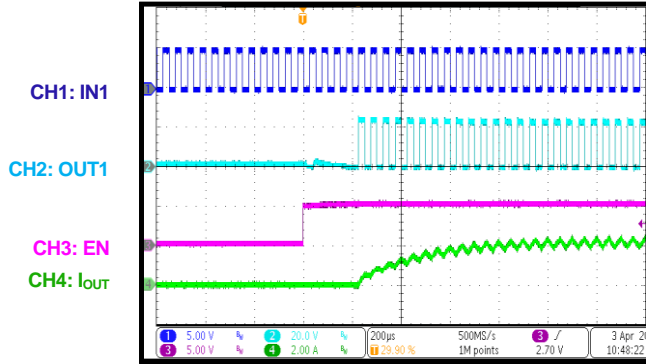
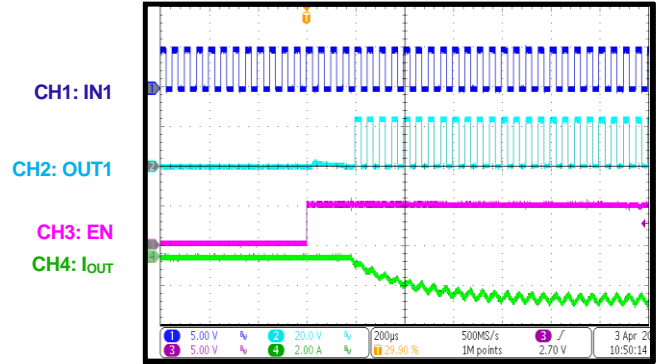
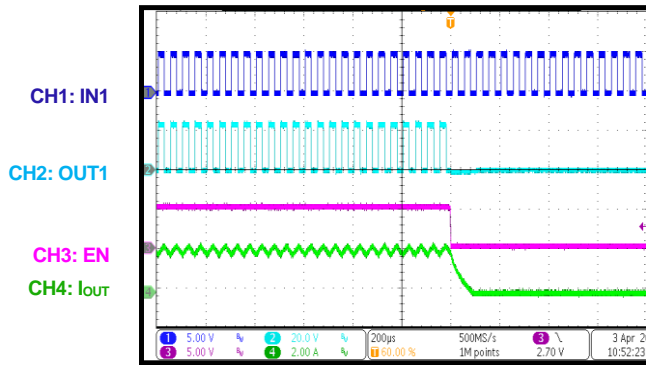
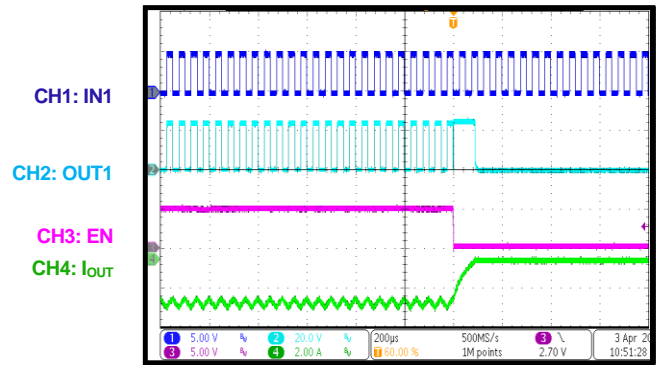
IC Enable
 $V_{IN} = 24V$, $IN1 = 20kHz / 50\%$, $IN2 = low$,
 load = $5\Omega + 700\mu H$

IC Enable
 $V_{IN} = 24V$, $IN1 = 20kHz / 50\%$, $IN2 = high$,
 load = $5\Omega + 700\mu H$

IC Disable
 $V_{IN} = 24V$, $IN1 = 20kHz / 50\%$, $IN2 = low$,
 load = $5\Omega + 700\mu H$

IC Disable
 $V_{IN} = 24V$, $IN1 = 20kHz/50\%$, $IN2 = high$,
 load = $5\Omega + 700\mu H$

OPERATION

The MP6619 is an H-bridge motor driver that operates from a supply voltage up to 28V and delivers a motor current up to 5A. Typically, the MP6619 is used to drive a brushed DC motor.

Input Logic

For the MP6619, control of each half-bridge is independent, using EN, IN1, and/or IN2 (see Table 1).

Table 1: Truth Table

EN	INx	OUTx
0	x	Z
1	0	L
1	1	H

Shutdown Mode

If the EN signal is pulled low, the MP6619 shuts down. In shutdown mode, all circuits and blocks are disabled, and the MP6619 consumes less than 1µA of shutdown current. There is about 150ns of deglitch time on EN to avoid a mistrigger.

Current Limit

The MP6619 has a programmable current limit function. The output current flowing through both two low-side MOSFETs is sensed by an external sense resistor. If the load current reaches the current trip threshold, a current limit condition is triggered, the entire H-bridge switches to a high-impedance state with all MOSFETs turned off. After a fixed off time (t_{ITRIP}), the MOSFETs are re-enabled, and the cycle repeats.

The current limit is triggered when the IFB pin voltage (V_{IFB}) reaches the current trip voltage (V_{ITRIP}). For example, if a 40mΩ sense resistor is connected from LSS to ground, and the current trip voltage (V_{ITRIP}) is 200mV, when the output current reaches 5A, V_{IFB} reaches 200mV and a current trip occurs.

Current Trip Voltage Setting

The current control trip value is set by connecting a resistor between ISET and GND. When ISET is floating, the current trip voltage is set to its default (200mV). If a resistor is connected between ISET and GND, the current

trip voltage can be reduced below 200mV to reduce power loss on the sense resistor. The IC needs about 0.3ms to detect whether a resistor is available on ISET when the IC starts up for the first time. During this time, the IC is not switching. The relationship of the current trip voltage and R_{ISET} is calculated with Equation (1):

$$V_{ITRIP} = 0.2 \times \frac{40}{R_{ISET} (\text{k}\Omega)} \quad (1)$$

For example, if R_{ISET} is 80kΩ, the trip voltage is 100mV. For better accuracy, a 40kΩ to 80kΩ resistance is recommended to achieve a 200mV to 100mV current trip voltage.

Start-Up Sequence

The IC needs about 0.3ms to detect whether a resistor is available on ISET when the IC starts up for the first time. During this time, the IC is not switching.

VCC LDO Regulator

The IC employs a low-dropout (LDO) regulator to provide a constant voltage (5V) at VCC. The VCC voltage (V_{VCC}) is used for the internal power supply of the logic circuit and driver circuit. When the input voltage drops, V_{VCC} drops together with V_{IN} . If V_{VCC} drops below 4.8V, the IC triggers a power reset sequence and shuts down. The IC resumes normal operation when V_{VCC} exceeds 5.1V.

High-Side MOSFET (HS-FET) Driver

The M1 and M3 high-side MOSFETs (HS-FETs) are N-channel MOSFETs. When M1 and M3 turn on, a bootstrap supply voltage (V_{BSTx}) across BST1 and BST2 is required. V_{BSTx} is generated by a combination of the internal charge pump and a 5V VCC. This allows the IC to operate at 100% duty cycle to provide enough driver voltage for the M1 and M3 HS-FETs.

Over-Current Protection (OCP)

The over-current protection (OCP) circuit limits the current through each MOSFET by reducing the gate driver voltage to the MOSFET. If the MOSFET current remains in the over-current (OC) condition (above I_{OCP}) for longer than the OC deglitch time, all MOSFETs in the H-bridge are disabled and nFAULT is driven low.

The driver remains disabled for t_{OCP} and is re-enabled automatically.

Input Over-Voltage Protection (OVP)

During operation, the energy stored in the load current is delivered to the input side during the freewheeling time. If V_{IN} and the output current (I_{OUT}) are high enough, the energy sent back to the input side causes V_{IN} to rise up. To avoid IC damage due to a high voltage spike, the IC employs input voltage protection.

If voltage applied to the VIN pin is above the OVP threshold, the H-bridge output is disabled and nFAULT is driven low. This protection is released when V_{IN} drops to a safe level.

Junction Over-Temperature Protection (OTP)

If the die temperature exceeds safe limits, all H-bridge MOSFETs are disabled and nFAULT is driven low. Once the die temperature has fallen to a safe level, normal operation resumes automatically.

Fault Indication Output (nFAULT)

The MP6619 provides an nFAULT pin that is driven active low if any of the protection circuits are activated. These fault conditions include over-current (OC), over-temperature (OT), and over-voltage (OV). nFAULT is also driven low when a current-limit trip occurs. nFAULT is an open-drain output, and requires an external pull-up resistor. Once any fault conditions are removed, nFAULT is pulled inactive high by the pull-up resistor.

Enable/Disable (EN)

To enable the MP6619, apply a logic high signal to EN, and the high-level signal time needs to be above about $10\mu s$. Pull EN to logic low, and set the low-level signal above 100ns to shut down the IC.

APPLICATION INFORMATION

Selecting the Input Capacitor

The input capacitor reduces the surge current drawn from the input supply and the switching noise from the device. The input capacitor impedance at the switching frequency should be less than the input source impedance to prevent the high-frequency switching current from passing through to the input. Ceramic capacitors with X5R or X7R dielectrics are recommended for their low ESR and small temperature coefficients. A higher-value capacitor is helpful for reducing input voltage ripple and noise. For most applications, two 22 μ F ceramic capacitors in parallel are sufficient. It is recommended to connect one capacitor to each VIN pin.

Setting the Output Current limit

If a resistor is connected between ISET and GND, the output current limit value can be calculated with Equation (2):

$$I_{OUT} = 0.2 \times \frac{40}{R_{ISET} (k\Omega)} \times \frac{1}{R_{ISEN} (\Omega)} \quad (2)$$

If ISET is left floating, the current limit setting formula is calculated with Equation (3):

$$I_{OUT} = \frac{0.2}{R_{ISEN} (\Omega)} \quad (3)$$

For example, if R_{ISET} is 80k Ω , then the trip voltage is 100mV. For better accuracy, a 40k Ω to 80k Ω resistance is recommended to achieve a 200mV to 100mV current trip voltage.

Setting the Sense Resistor

The power loss of the sensing resistor (P_{LOSS_RIFB}) can be calculated with Equation (4):

$$P_{LOSS_RIFB} = \frac{V_{ITRIP}^2}{R_{ISEN} (\Omega)} \quad (4)$$

To guarantee a current reference, the nominated power rating of the sensing resistor is recommended to be twice the calculated power loss with at least a 1% accuracy resistor.

PCB Layout Guidelines

Efficient PCB layout is critical for stable operation. For the best results, refer to Figure 2 on page 11 and follow the guidelines below:

1. Place the input capacitor close to VIN.
2. Use a wide copper plane for the input, output, and GND connecting wire to improve thermal performance.
3. Place as many GND vias near the output and input capacitor as possible to improve thermal performance.
4. Keep the sense resistor loop as short as possible.
5. Keep the current-sense feedback signal far away from noise sources.

TYPICAL APPLICATION CIRCUIT

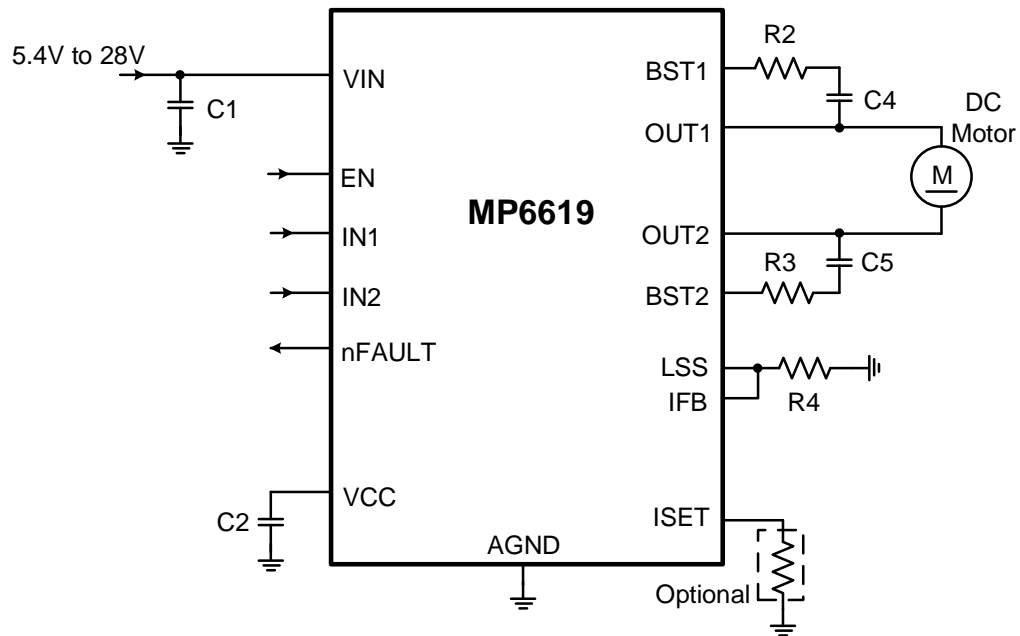
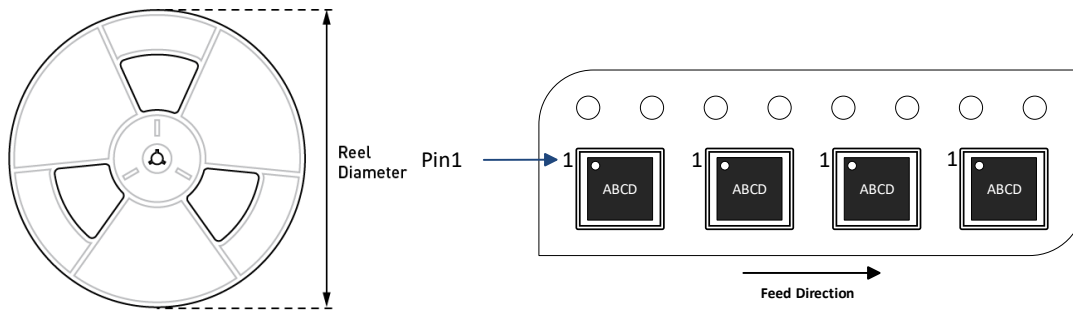

Figure 2: Typical Application Circuit

CARRIER INFORMATION

Part Number	Package Description	Quantity/ Reel	Quantity/ Tube	Quantity/ Tray	Reel Diameter	Carrier Tape Width	Carrier Tape Pitch
MP6619GQ-Z	QFN (5mmx5mm)	5000	N/A	N/A	13in	12mm	8mm

REVISION HISTORY

Revision #	Revision Date	Description	Pages Updated
1.0	1/21/2021	Initial Release	-

Notice: The information in this document is subject to change without notice. Please contact MPS for current specifications. Users should warrant and guarantee that third-party Intellectual Property rights are not infringed upon when integrating MPS products into any application. MPS will not assume any legal responsibility for any said applications.

Mouser Electronics

Authorized Distributor

Click to View Pricing, Inventory, Delivery & Lifecycle Information:

[Monolithic Power Systems \(MPS\):](#)

[MP6619GQ-P](#) [MP6619GQ-Z](#)

Looking for pricing, stock, or lifecycle information?

Click below to explore more details on WIN SOURCE:

- ⊖ [View MP6619GQ-P on WIN SOURCE](#)
- ⊖ [Monolithic Power Systems Inc. Information](#)

Optimize Your Supply Chain with WIN SOURCE Solutions

- ✓ Global Sourcing Solution
- ✓ Obsolete Management
- ✓ Cost Control Management
- ✓ Shortage Management
- ✓ Alternative Solution
- ✓ Excess Inventory Management