



**THE DATASHEET OF
PI4ULS3V4103XEAEX**



Features

- SIM Card Voltage Range 1.65V to 3.6V
- Host Voltage Range: 1.1V to 2.0V
- Automatic Level Translation
- Low Operating/Shutdown Current
- 8kV ESD HBM for SIM Card Pins
- 2kV ESD HBM for All Other Pins
- Meets EMV Fault Tolerance Requirements
- Totally Lead-Free & Fully RoHS Compliant (Notes 1 & 2)
- Halogen and Antimony Free. "Green" Device (Note 3)
- For automotive applications requiring specific change control (i.e. parts qualified to AEC-Q100/101/104/200, PPAP capable, and manufactured in IATF 16949 certified facilities), please [contact us](#) or your local Diodes representative.
<https://www.diodes.com/quality/product-definitions/>
- Packaging (Pb-free & Green):
 - 10-Contact, 1.4mmx1.8mm X1QFN (XEA)

Description

The DIODES™ PI4ULS3V4103 provides the power conversion and signal level translation needed for advanced cellular telephones to interface with 1.8V and 3V subscriber identity modules (SIMs). The device meets all requirements for 1.8V or 3V SIMs. Internal level translators allow controller operating with supplier as low as 1.2V to interface with 1.8V or 3V Smart Cards.

Applications

- GSM, TD-SCDMA
- Wireless Point-to-Sale Terminals
- Multiple SIM Card Interfaces

Notes:

1. No purposely added lead. Fully EU Directive 2002/95/EC (RoHS), 2011/65/EU (RoHS 2) & 2015/863/EU (RoHS 3) compliant.
2. See <https://www.diodes.com/quality/lead-free/> for more information about Diodes Incorporated's definitions of Halogen- and Antimony-free, "Green" and Lead-free.
3. Halogen- and Antimony-free "Green" products are defined as those which contain <900ppm bromine, <900ppm chlorine (<1500ppm total Br + Cl) and <1000ppm antimony compounds.

DIODES is a trademark of Diodes Incorporated in the United States and other countries.

The Diodes logo is a registered trademark of Diodes Incorporated in the United States and other countries.

Pin Configuration

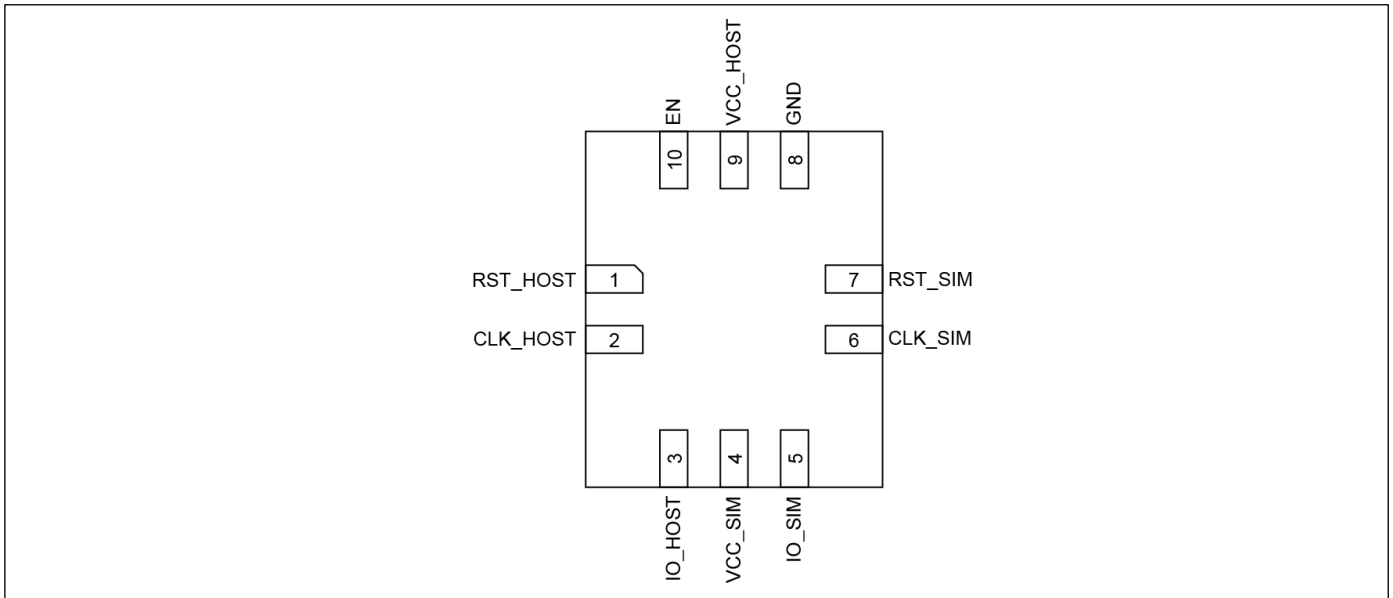

Pin Description

Pin#	Name	Type	Description
9	VCC_HOST	P	Power Supply for Host side pins
4	VCC_SIM	P	Power Supply for SIM card side pins
10	EN	I	Host Controller driven Enable Inputs. EN=HIGH output active, EN=LOW shutdown the device.
1	RST_HOST	I	Reset input from host controller.
2	CLK_HOST	I	Clock input from host controller.
3	IO_HOST	I/O	Host controller bidirectional data input/output.
7	RST_SIM	O	Reset output pin for the SIM card.
6	CLK_SIM	O	Clock output pin for the SIM card.
5	IO_SIM	I/O	SIM Card bidirectional data input/output.
8	GND	P	Ground for the SIM card and host controller.

Maximum Ratings

Storage Temperature	-55°C to +150°C
Ambient Temperature	-40°C to +85°C
Supply Voltage to Ground Potential	-0.5V to +4.6V
Host Side Input Voltage	-0.5V to +2.2V
Card Side Input Voltage	-0.5V to +4.6V
Power Dissipation Continuous	1000mW
I/O Latch-up Current	-100mA to +100mA
ESD, HBM for SIM card Pins	-8000V to +8000V
ESD, HBM for other Pins	-2000V to +2000V

Note:

Stresses greater than those listed under MAXIMUM RATINGS may cause permanent damage to the device. This is a stress rating only and functional operation of the device at these or any other conditions above those indicated in the operational sections of this specification is not implied. Exposure to absolute maximum rating conditions for extended periods may affect reliability.

The device is guaranteed to meet performance specifications from 0°C to 85°C. Specification over the -40°C to 85°C operating temperature range are assured by design, characterization and correlation with statistical controls.

Icc based on long-term current density limitation.

DC Electrical Characteristics

($1.1V \leq V_{CC_HOST} \leq 2.0V$, $1.65V \leq V_{CC_SIM} \leq 3.6V$, $T_A = -40^\circ C$ to $85^\circ C$, unless otherwise noted.)

Parameter	Description	Test Conditions	Min	Typ.	Max	Unit
Host Side Power Supply						
V _{CC-HOST}	Host side operating Voltage		1.1	-	2.0	V
I _{CC-HOST}	V _{CC-HOST} Operating Current	EN=High, V _I = V _{CC} , I _O = 0	-	-	10	μA
I _{CCS-HOST}	V _{CC-HOST} Shutdown Current	EN=GND	-	-	60	
SIM Card Side Power Supply						
V _{CC-SIM}	SIM side operating Voltage		1.65	-	3.6	V
I _{CC-SIM}	V _{CC-SIM} Operating Current	EN=High, V _I = V _{CC} , I _O = 0	-	-	10	μA
I _{CCS-SIM}	V _{CC-SIM} Shutdown Current	EN=GND	-	-	2	
EN pins						
V _{IL}	Low Level input Voltage		-	-	0.3x V _{CC-HOST}	V
V _{IH}	High Level input Voltage		0.7x V _{CC-HOST}	-	-	V
Host Side CLK, RST, IO pins						
V _{IL}	Low Level input Voltage		-	-	0.25 x V _{CC-HOST}	V
V _{IH}	High Level input Voltage		0.75x V _{CC-HOST}	-	-	V
V _{OL}	Low Level Output Voltage (IO_HOST pin)	I _{OL} = 1 mA	-	-	0.3	V
V _{OH}	High Level Output Voltage (IO_HOST pin)	I _{OH} = -10μA	0.7 x V _{CC-HOST}	-	-	V
SIM Card Side CLK, RST, IO pins						
V _{IL}	Low Level input Voltage (IO_SIM pin)		-	-	0.3 x V _{CC-SIM}	V
V _{IH}	High Level input Voltage (IO_SIM pin)		0.7x V _{CC-SIM}	-	-	V
V _{OL}	High Level Output Voltage (IO_SIM pin)	I _{OL} = 1 mA	-	-	0.3	V
	High Level Output Voltage (RST_SIM, CLK_SIM pin)	I _{OL} = 1 mA	-	-	0.2 x V _{CC-SIM}	V
V _{OH}	High Level Output Voltage (IO_SIM pin)	I _{OH} = -10μA	0.7x V _{CC-SIM}	-	-	V
	High Level Output Voltage (RST_SIM, CLK_SIM pins)	I _{OH} = -1mA	0.8x V _{CC-SIM}	-	-	V
Resistors and IO capacitance						
R _s	series resistance	IO_SIM, RST_SIM, CLKSIM	-	44	-	Ω

Parameter	Description	Test Conditions	Min	Typ.	Max	Unit
R _{PU}	Pull-up resistors	IO_HOST	-	20	-	kΩ
		IO_SIM	-	15	-	kΩ
		EN	-	50	-	kΩ
C _{IO}	input/output capacitance	Host side pins	-	7	-	pF
		Card Side pins	-	15	-	pF
		EN pin	-	7	-	pF

Dynamic Characteristics

(1.1V ≤ V_{CC_HOST} ≤ 2.0V, 1.65V ≤ V_{CC_SIM} ≤ 3.6V, T_A = -40°C to 85°C, unless otherwise noted.)

Parameter	Description	Test Conditions	Min	Typ.	Max	Unit
VCC_HOST = 1.8 V; VCC_SIM = 2.95 V; SIM card C_L ≤ 30 pF; host C_L ≤ 10 pF						
t _{PD}	propagation delay	SIM card side to Host side	-	8	15	ns
		Host side to SIM card side	-	8	15	ns
t _R	Rising time		-	-	10	ns
t _F	Falling time		-	-	10	ns
tsk(o)	output skew time	between channels; IO_SIM and CLK_SIM	-	-	2	ns
fclk	clock frequency	Clk_SIM			25	MHz
VCC_HOST = 1.2 V; VCC_SIM = 1.8 V; SIM card C_L ≤ 30 pF; host C_L ≤ 10 pF						
t _{PD}	propagation delay	SIM card side to Host side	-	8	15	ns
		Host side to SIM card side	-	8	15	ns
t _R	Rising time		-	-	10	ns
t _F	Falling time		-	-	10	ns
tsk(o)	output skew time	between channels; IO_SIM and CLK_SIM	-	-	2	ns
fclk	clock frequency	Clk_SIM			25	MHz

Function Block Diagram

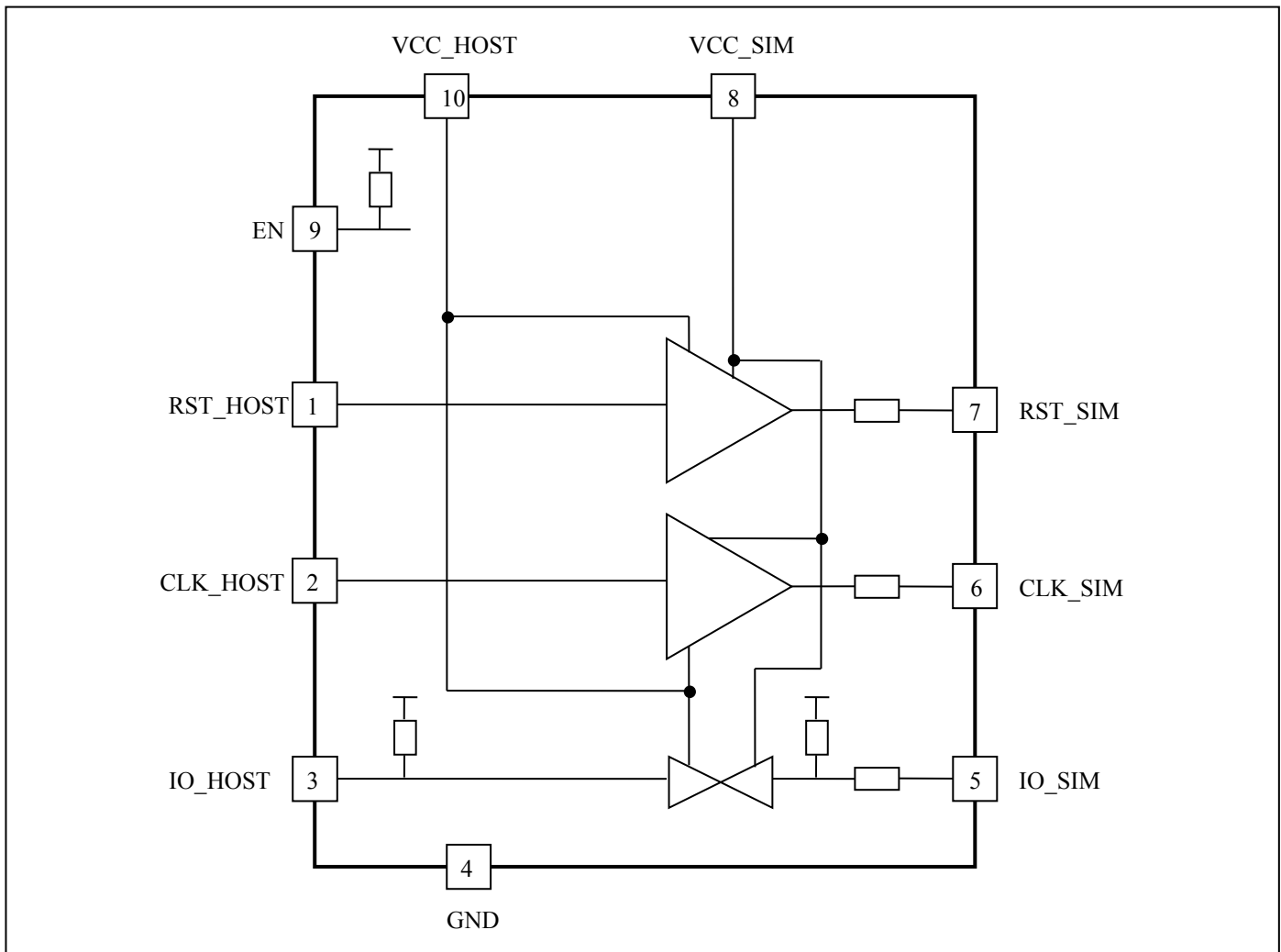

Function Description

VCC_HOST (Pin 10): Power. Supply voltage of HOST controller side signal.

VCC_SIM (Pin 8): Power. Supply voltage of SIM card side signal.

RST_HOST (Pin 1): Input. Supply the reset signal to the card through RST. It is level shifted and transmitted directly to the RST pin of the selected card.

CLK_HOST (Pin 2): Input. Supply the clock signal to the card through CLK. It is level shifted and transmitted directly to the CLK pin of the card.

IO_HOST (Pin 3): Input / Output. Connect this pin to microcontroller side I/O pin. The DATA pin provides the bidirectional communication path to card. The pin possesses a weak pull-up, allowing the controller to use an open drain output with capable of sinking greater than 1mA and maintain a HIGH state during shutdown, as long as V_{DD} is powered.

RST_SIM (Pin 7): Reset output to the card socket RST pin and the reset signal is derived from the RSTIN pin with level shift function. The RST pin is shut down until V_{CC} attain its correct value. This pin is pulled to ground during shutdown.

CLK_SIM (Pin 6): Clock output to the card socket CLK pin and the clock signal is derived from the CLKIN pin with level shift functions. The CLK pin is gated off until V_{CC} attain its correct value. This pin is pulled to ground during shutdown. Fast rising and falling edges necessitate careful board layout for the CLK node.

IO_SIM (Pin 5): Data output/input to the card socket I/O pin, transmit /receive data to/from the DATA pin with level shift

function. The I/O pin is gated off until V_{CC} attain its correct value. The SIM card output must be on an open-drain driver capable of sourcing $>1\text{mA}$.

EN (Pin 9): Input. EN pin enable and disable V_{CC} . RST, CLK, I/O pins are shut down until V_{CC} attain its correct value.

GND (Pin 4): Chip Ground. This pad must be soldered directly to a PCB ground plane.

Power Off State and Sequence

In application, there could be a condition when V_{CC_HOST} is powered while V_{CC_SIM} is powered off.

The SIM card side pins (CLK_SIM, RST_SIM, IO_SIM) would be turned off in this conditions, but there're ESD diodes connected to V_{CC_SIM} , like in bellow figure 1. If there are voltages on these pins while the V_{CC_SIM} is not powered, it will have leakage current pass through the diodes.

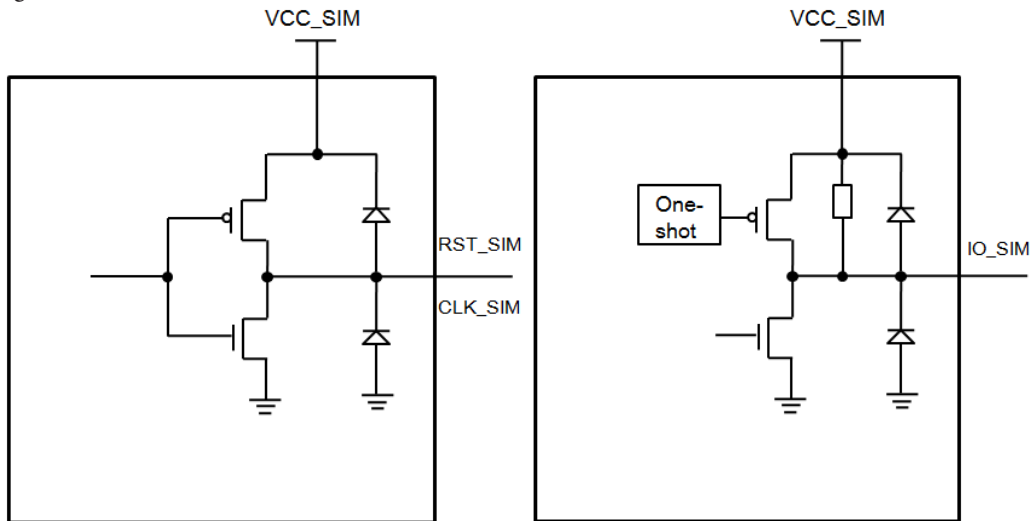
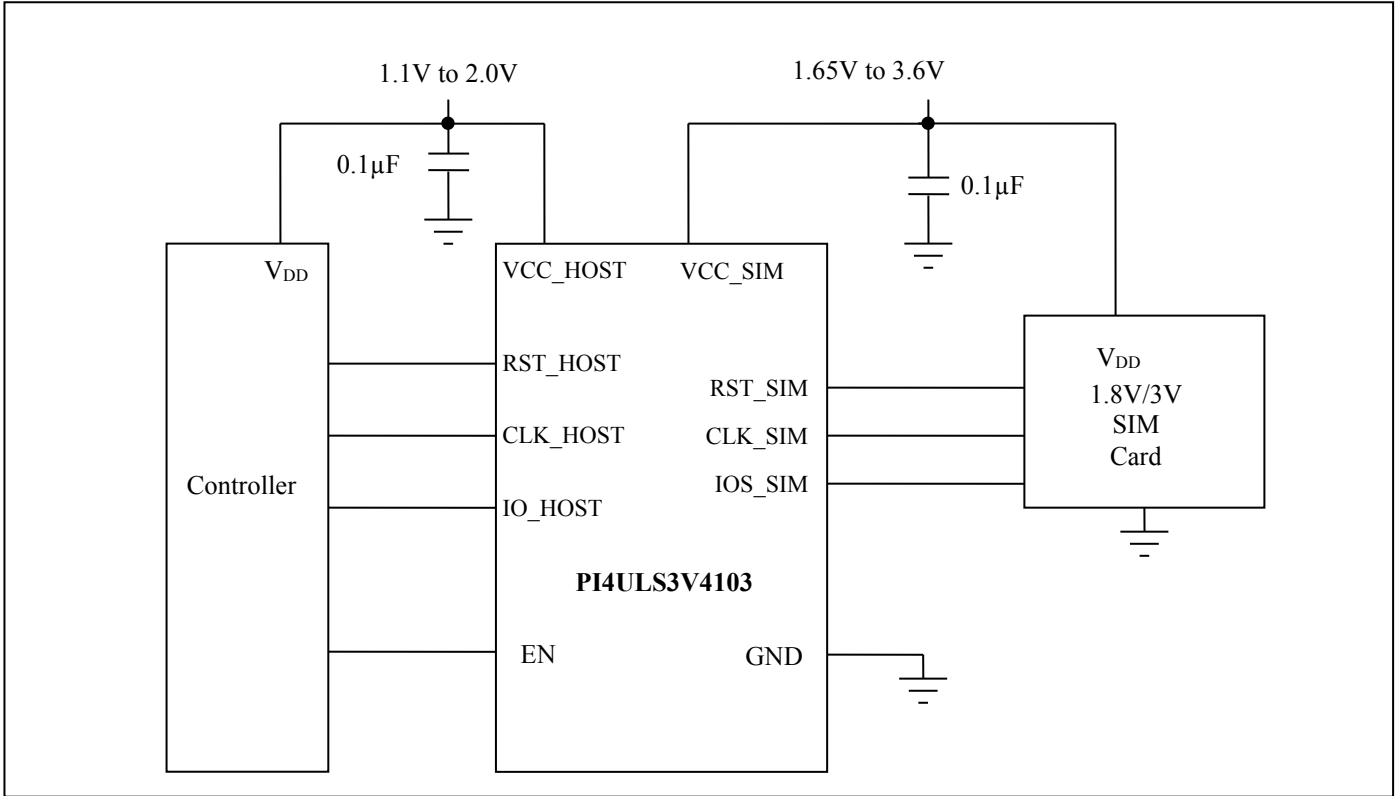

Figure 1: Structure of SIM Card side Pins

Application Circuit

The application circuit for PI4ULS3V4103 which shows the typical interface with a SIM card, is shown in below Figure.



Part Marking

\bar{E} Z
 ZY

EZ: PI4ULS3V4103XEAE
 Z: Die Rev
 Y: One Character Shorted Date Code
 Bar Above First Character Denotes Pin 1 Indicator

Packaging Mechanical

10-X1QFN (XEA)

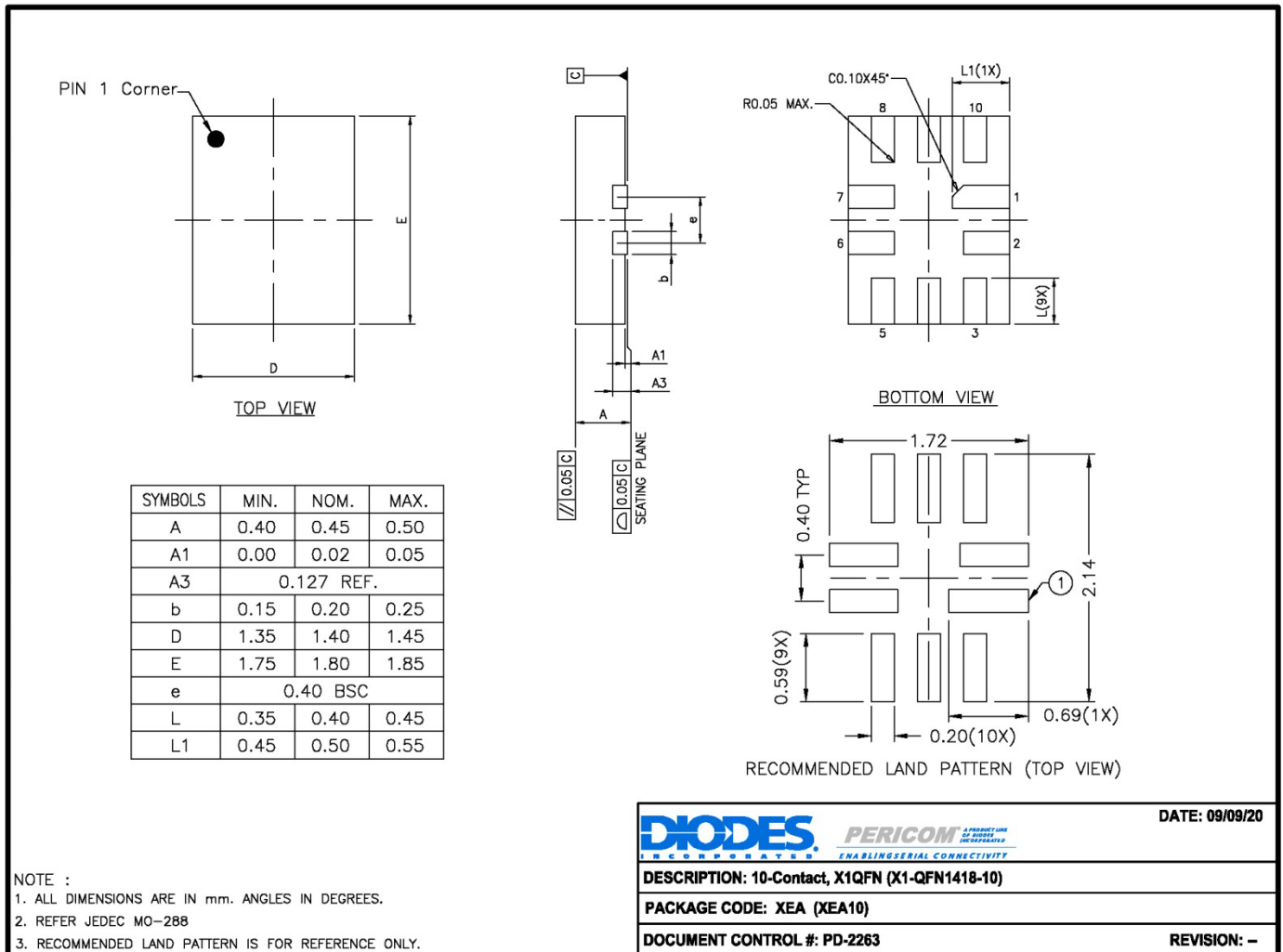

20-0521

For latest package info.

please check: <http://www.diodes.com/design/support/packaging/pericom-packaging/packaging-mechanicals-and-thermal-characteristics/>

Ordering Information

Part Number	Package Code	Package Description
PI4ULS3V4103XEAEX	XEA	10-contact, X1QFN (X1-QFN1418-10)

Notes:

- No purposely added lead. Fully EU Directive 2002/95/EC (RoHS), 2011/65/EU (RoHS 2) & 2015/863/EU (RoHS 3) compliant.
- See <https://www.diodes.com/quality/lead-free/> for more information about Diodes Incorporated's definitions of Halogen- and Antimony-free, "Green" and Lead-free.
- Halogen- and Antimony-free "Green" products are defined as those which contain <900ppm bromine, <900ppm chlorine (<1500ppm total Br + Cl) and <1000ppm antimony compounds.
- E = Pb-free and Green
- X suffix = Tape/Reel

IMPORTANT NOTICE



1. DIODES INCORPORATED (Diodes) AND ITS SUBSIDIARIES MAKE NO WARRANTY OF ANY KIND, EXPRESS OR IMPLIED, WITH REGARDS TO ANY INFORMATION CONTAINED IN THIS DOCUMENT, INCLUDING, BUT NOT LIMITED TO, THE IMPLIED WARRANTIES OF MERCHANTABILITY, FITNESS FOR A PARTICULAR PURPOSE OR NON-INFRINGEMENT OF THIRD PARTY INTELLECTUAL PROPERTY RIGHTS (AND THEIR EQUIVALENTS UNDER THE LAWS OF ANY JURISDICTION).
2. The Information contained herein is for informational purpose only and is provided only to illustrate the operation of Diodes' products described herein and application examples. Diodes does not assume any liability arising out of the application or use of this document or any product described herein. This document is intended for skilled and technically trained engineering customers and users who design with Diodes' products. Diodes' products may be used to facilitate safety-related applications; however, in all instances customers and users are responsible for (a) selecting the appropriate Diodes products for their applications, (b) evaluating the suitability of Diodes' products for their intended applications, (c) ensuring their applications, which incorporate Diodes' products, comply the applicable legal and regulatory requirements as well as safety and functional-safety related standards, and (d) ensuring they design with appropriate safeguards (including testing, validation, quality control techniques, redundancy, malfunction prevention, and appropriate treatment for aging degradation) to minimize the risks associated with their applications.
3. Diodes assumes no liability for any application-related information, support, assistance or feedback that may be provided by Diodes from time to time. Any customer or user of this document or products described herein will assume all risks and liabilities associated with such use, and will hold Diodes and all companies whose products are represented herein or on Diodes' websites, harmless against all damages and liabilities.
4. Products described herein may be covered by one or more United States, international or foreign patents and pending patent applications. Product names and markings noted herein may also be covered by one or more United States, international or foreign trademarks and trademark applications. Diodes does not convey any license under any of its intellectual property rights or the rights of any third parties (including third parties whose products and services may be described in this document or on Diodes' website) under this document.
5. Diodes' products are provided subject to Diodes' Standard Terms and Conditions of Sale (<https://www.diodes.com/about/company/terms-and-conditions/terms-and-conditions-of-sales/>) or other applicable terms. This document does not alter or expand the applicable warranties provided by Diodes. Diodes does not warrant or accept any liability whatsoever in respect of any products purchased through unauthorized sales channel.
6. Diodes' products and technology may not be used for or incorporated into any products or systems whose manufacture, use or sale is prohibited under any applicable laws and regulations. Should customers or users use Diodes' products in contravention of any applicable laws or regulations, or for any unintended or unauthorized application, customers and users will (a) be solely responsible for any damages, losses or penalties arising in connection therewith or as a result thereof, and (b) indemnify and hold Diodes and its representatives and agents harmless against any and all claims, damages, expenses, and attorney fees arising out of, directly or indirectly, any claim relating to any noncompliance with the applicable laws and regulations, as well as any unintended or unauthorized application.
7. While efforts have been made to ensure the information contained in this document is accurate, complete and current, it may contain technical inaccuracies, omissions and typographical errors. Diodes does not warrant that information contained in this document is error-free and Diodes is under no obligation to update or otherwise correct this information. Notwithstanding the foregoing, Diodes reserves the right to make modifications, enhancements, improvements, corrections or other changes without further notice to this document and any product described herein. This document is written in English but may be translated into multiple languages for reference. Only the English version of this document is the final and determinative format released by Diodes.
8. Any unauthorized copying, modification, distribution, transmission, display or other use of this document (or any portion hereof) is prohibited. Diodes assumes no responsibility for any losses incurred by the customers or users or any third parties arising from any such unauthorized use.
9. This Notice may be periodically updated with the most recent version available at <https://www.diodes.com/about/company/terms-and-conditions/important-notice>

DIODES is a trademark of Diodes Incorporated in the United States and other countries.
The Diodes logo is a registered trademark of Diodes Incorporated in the United States and other countries.
© 2022 Diodes Incorporated. All Rights Reserved.







www.diodes.com

Looking for pricing, stock, or lifecycle information?

Click below to explore more details on WIN SOURCE:

-  [View PI4ULS3V4103XEAEX on WIN SOURCE](#)
-  [Diodes Incorporated Information](#)

Optimize Your Supply Chain with WIN SOURCE Solutions

-  Global Sourcing Solution
-  Obsolete Management
-  Cost Control Management
-  Shortage Management
-  Alternative Solution
-  Excess Inventory Management