



**THE DATASHEET OF
WW12XR430FTL**



APPROVAL SHEET

WW12X, WW08X, WW06X, WW04X

±1%, ±5%

Thick Film Low Ohm Chip Resistors

Size 1206, 0805, 0603, 0402

RoHS 2 Compliant with exemption 7C-I
Halogen free



FEATURE

1. High power rating and compact size
2. High reliability and stability
3. Reduced size of final equipment
4. RoHS 2 Compliant with exemption 7C-I and Halogen free products

APPLICATION

- Power supply
- PDA
- Digital meter
- Computer
- Automotives
- Battery charger
- DC-DC power converter

DESCRIPTION

The resistors are constructed in a high grade ceramic body (aluminum oxide). Internal metal electrodes are added at each end and connected by a resistive paste that is applied to the top surface of the substrate. The extra protective metal film is added onto top side electrodes to protect termination from sulfuration. The composition of the paste is adjusted to give the approximate resistance required and the value is trimmed to within tolerance by laser cutting of this resistive layer.

The resistive layer is covered with a protective coat. Finally, the two external end terminations are added. For ease of soldering the outer layer of these end terminations is a Tin (lead free) alloy.

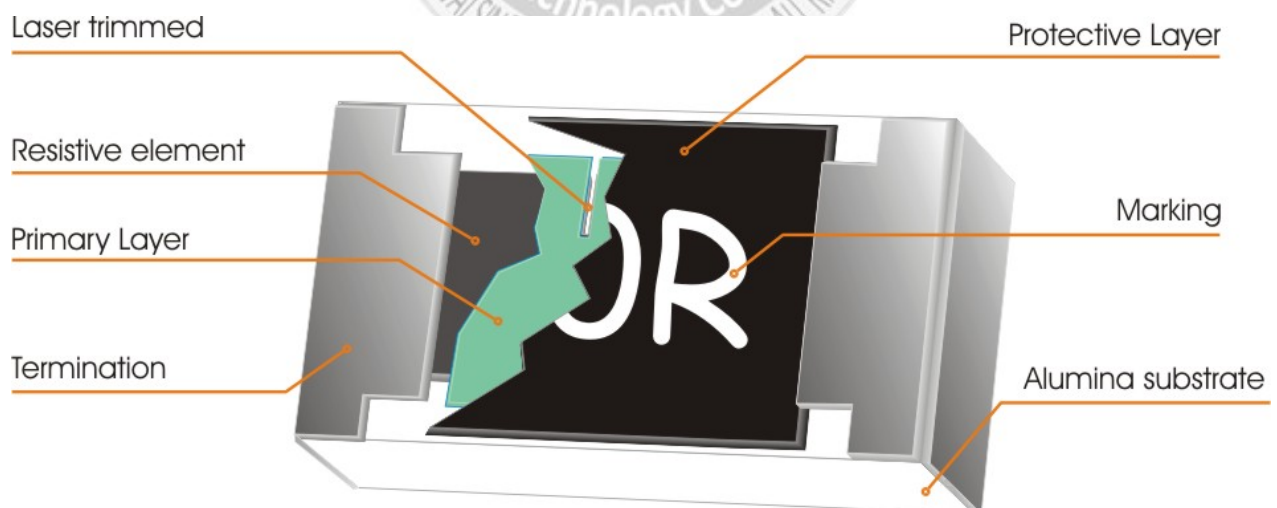

Fig 1. Construction of a Chip-R

QUICK REFERENCE DATA

Item	General Specification			
Series No.	WW12X	WW08X	WW06X	WW04X
Size code	1206 (3216)	0805 (2012)	0603 (1608)	0402(1005)
Resistance Tolerance	±5%, ±1%			
Resistance Range	0.010Ω ~ 0.976Ω	0.020Ω ~ 0.976Ω	0.10Ω ~ 0.976Ω	
TCR (ppm/°C)	0.01Ω ≤ Rn < 0.05Ω	≤ 2100 ppm/°C	N/a	
	0.05Ω ≤ Rn < 0.10Ω	≤ 1000 ppm/°C	N/a	
	0.10Ω ≤ Rn < 0.50Ω	≤ 500 ppm/°C	≤ 500 ppm/°C	≤ 600 ppm/°C
	0.50Ω ≤ Rn < 1Ω	≤ 400 ppm/°C	≤ 300 ppm/°C	≤ 600 ppm/°C
Max. dissipation at T _{amb} =70°C	1/4 W	1/8 W	1/10 W	1/16 W
Max. Operation Voltage (DC or RMS)	200V	100V	50V	
Max. Overload voltage (DC or RMS)	400V	200V	100V	
Climatic category (IEC 60068)	55/155/56			

Note :

1. This is the maximum voltage that may be continuously supplied to the resistor element, see "IEC publication 60115-8"
2. Max. Operation Voltage : So called RCWV (Rated Continuous Working Voltage) is determined by

$$RCWV = \sqrt{\text{Rated Power} \times \text{Resistance Value}} \text{ or Max. RCWV listed above, whichever is lower.}$$

DIMENSIONS (unit : mm)

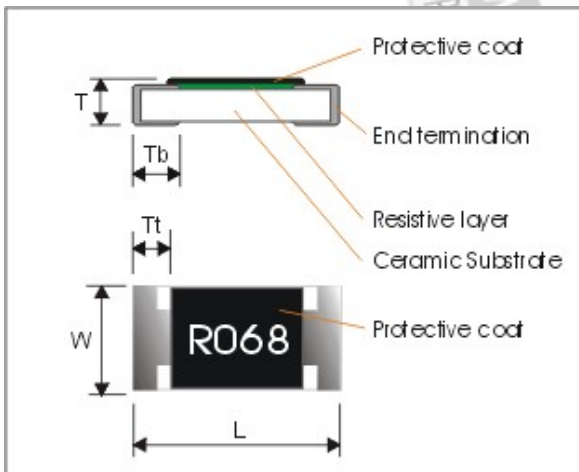

Symbol	WW12X	WW08X	WW06X	WW04X
L	3.10 ± 0.10	2.00 ± 0.10	1.60 ± 0.10	1.00 ± 0.05
W	1.60 ± 0.10	1.25 ± 0.10	0.80 ± 0.10	0.50 ± 0.05
T	0.60 ± 0.15	0.50 ± 0.15	0.45 ± 0.15	0.35 ± 0.05
Tt	0.50 ± 0.20	0.40 ± 0.20	0.30 ± 0.10	0.20 ± 0.10
Tb	0.45 ± 0.20	0.40 ± 0.20	0.30 ± 0.20	0.25 ± 0.10

CATALOGUE NUMBERS

The resistors have a catalogue number starting with .

WW12	X	R020	F	T	L
Size code WW12 : 1206 WW08 : 0805 WW06 : 0603 WW04 : 0402	Type code X : Normal	Resistance code E96 +E24: R is first digit followed by 3 significant digits. 0.020Ω = R020 0.510Ω = R510 0.025Ω = R025	Tolerance code J : ±5% F : ±1%	Packaging code T : 7" Reel taping Q : 10" Reel taping G : 13" Reel taping D : 7" reel 20Kpcs only for 0402	Termination code L = Sn base (leadfree)

Tape packaging:

WW12,WW08,WW06 : 8mm width paper taping 5,000pcs per 7" reel; 10,000pcs per 10" reel; 20,000pcs per 13" reel.

WW04: 8mm width paper taping 10,000pcs per 7" reel; 20,000pcs per 7" reel; 70,000pcs per 13" reel.

MARKING

- WW04X series has no marking on the product overcoat for both 5% & 1%.
- 4-digit marking for 1206, 0805 size

Each resistor is marked with a four-digit code on the protective coating to designate the nominal resistance value.

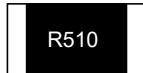

R010 = 0.010Ω (10mΩ)
R510 = 0.510Ω (510mΩ)

- 3-digit marking for 0603 size

Rule	Series	Resistance Range	Example	Table
"R" followed by 2 significant digits if the 4th digit is "0"	E24	100mΩ ~910mΩ	110mΩ= R10 220mΩ= R22 510mΩ= R51	Table-1
The 1st two digit codes are referring to the CODE on the table, the 3rd code is the index of resistance value : "Z"	E96	100mΩ ~976mΩ	178mΩ= 25Z 221mΩ= 34Z	Table-2
Others are no marking printed.	Out of E24 & E96	100mΩ ~976mΩ	400mΩ= No marking	-

■ Table-1 0603 E24 100mΩ ~910mΩ

Series	R value	Marking	Series	R value	Marking	Series	R value	Marking	Series	R value	Marking
E24	100mΩ	R10	E24	200mΩ	R20	E24	390mΩ	R39	E24	680mΩ	R68
E24	110mΩ	R11	E24	220mΩ	R22	E24	430mΩ	R43	E24	750mΩ	R75
E24	120mΩ	R12	E24	240mΩ	R24	E24	470mΩ	R47	E24	820mΩ	R82
E24	130mΩ	R13	E24	270mΩ	R27	E24	500mΩ	R50	E24	910mΩ	R91
E24	150mΩ	R15	E24	300mΩ	R30	E24	510mΩ	R51			
E24	160mΩ	R16	E24	330mΩ	R33	E24	560mΩ	R56			
E24	180mΩ	R18	E24	360mΩ	R36	E24	620mΩ	R62			

■ Table-2 0603 E96 100mΩ ~976mΩ

Code	R value	Marking	Code	R value	Marking	Code	R value	Marking	Code	R value	Marking
02	102mΩ	02Z	28	191mΩ	28Z	52	340mΩ	52Z	75	590mΩ	75Z
03	105mΩ	03Z	29	196mΩ	29Z	53	348mΩ	53Z	76	604mΩ	76Z
04	107mΩ	04Z	31	205mΩ	31Z	54	357mΩ	54Z	77	619mΩ	77Z
06	113mΩ	06Z	32	210mΩ	32Z	55	365mΩ	55Z	78	634mΩ	78Z
07	115mΩ	07Z	33	215mΩ	33Z	56	374mΩ	56Z	79	649mΩ	79Z
08	118mΩ	08Z	34	221mΩ	34Z	57	383mΩ	57Z	80	665mΩ	80Z
09	121mΩ	09Z	35	226mΩ	35Z	58	392mΩ	58Z	81	681mΩ	81Z
10	124mΩ	10Z	36	232mΩ	36Z	59	402mΩ	59Z	82	698mΩ	82Z
11	127mΩ	11Z	37	237mΩ	37Z	60	412mΩ	60Z	83	715mΩ	83Z
13	133mΩ	13Z	38	243mΩ	38Z	61	422mΩ	61Z	84	732mΩ	84Z
14	137mΩ	14Z	39	249mΩ	39Z	62	432mΩ	62Z	86	768mΩ	86Z
15	140mΩ	15Z	40	255mΩ	40Z	63	442mΩ	63Z	87	787mΩ	87Z
16	143mΩ	16Z	41	261mΩ	41Z	64	453mΩ	64Z	88	806mΩ	88Z
17	147mΩ	17Z	42	267mΩ	42Z	65	464mΩ	65Z	89	825mΩ	89Z
19	154mΩ	19Z	43	274mΩ	43Z	66	475mΩ	66Z	90	845mΩ	90Z
20	158mΩ	20Z	44	280mΩ	44Z	67	487mΩ	67Z	91	866mΩ	91Z
21	162mΩ	21Z	45	287mΩ	45Z	68	499mΩ	68Z	92	887mΩ	92Z
22	165mΩ	22Z	46	294mΩ	46Z	69	511mΩ	69Z	93	909mΩ	93Z
23	169mΩ	23Z	47	301mΩ	47Z	70	523mΩ	70Z	94	931mΩ	94Z
24	174mΩ	24Z	48	309mΩ	48Z	71	536mΩ	71Z	95	953mΩ	95Z
25	178mΩ	25Z	49	316mΩ	49Z	72	549mΩ	72Z	96	976mΩ	96Z
26	182mΩ	26Z	50	324mΩ	50Z	73	562mΩ	73Z			
27	187mΩ	27Z	51	332mΩ	51Z	74	576mΩ	74Z			

FUNCTIONAL DESCRIPTION

Product characterization

Standard values of nominal resistance are taken from the E24& E96 series for resistors with a tolerance of $\pm 0.5\%$, $\pm 0.1\%$. The values of the E24/E96 series are in accordance with "IEC publication 60063"

Derating

The power that the resistor can dissipate depends on the operating temperature; see Fig.2

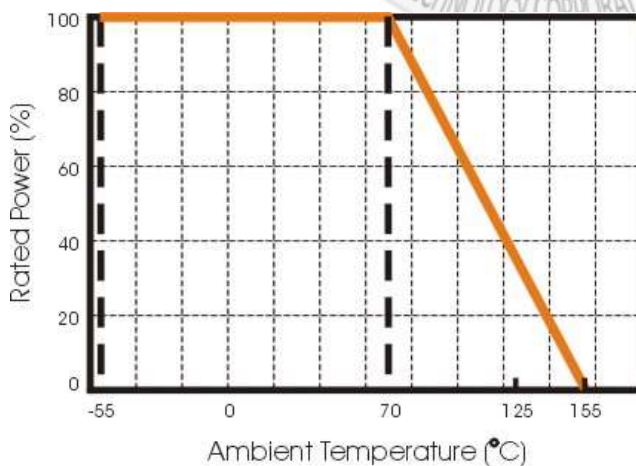

Figure 2 Maximum dissipation in percentage of rated power as a function of the ambient temperature

MOUNTING

Due to their rectangular shapes and small tolerances, Surface Mountable Resistors are suitable for handling by automatic placement systems.

Chip placement can be on ceramic substrates and printed-circuit boards (PCBs).

Electrical connection to the circuit is by individual soldering condition.

The end terminations guarantee a reliable contact.

Storage and Handling Conditions:

1. Products are recommended to be used up within two years since operation date as ensured shelf life. Check solderability in case shelf life extension is needed.

2. To store products with following condition:

Temperature :5 to 40°C

Humidity :20 to 70% relative humidity

3. Caution:

a. Don't store products in a corrosive environment such as sulfide, chloride gas, or acid.

It may cause oxidation of electrode, which easily be resulted in poor soldering.

b. To store products on the shelf and avoid exposure to moisture.

c. Don't expose products to excessive shock, vibration, direct sunlight and so on.

SOLDERING CONDITION follows J-STD-020D

The robust construction of chip resistors allows them to be completely immersed in a solder bath of 260°C for 10 seconds. Therefore, it is possible to mount Surface Mount Resistors on one side of a PCB and other discrete components on the reverse (mixed PCBs).

Surface Mount Resistors are tested for solderability at 235°C during 2 seconds. The test condition for no leaching is 260°C for 30 seconds.

Typical examples of soldering processes that provide reliable joints without any damage are given in Fig 3.

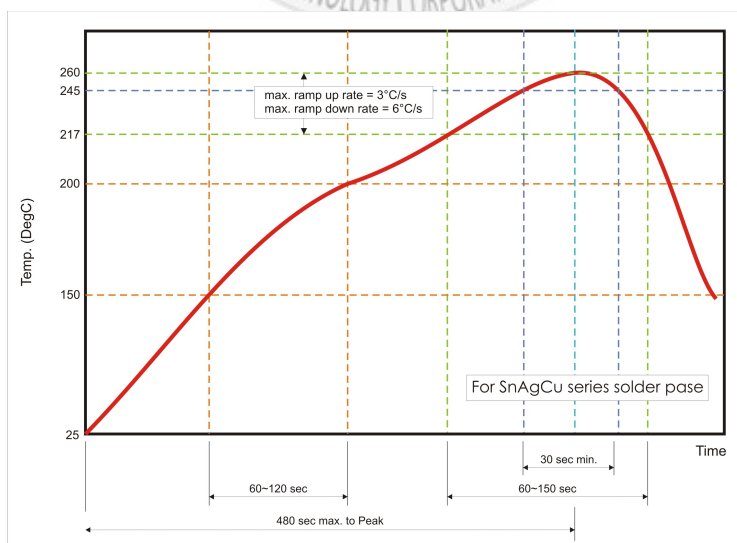

Fig 3. Recommended IR reflow soldering profile for SMT process with SnAgCu series solder paste

TEST AND REQUIREMENTS(JIS C 5201-1 : 1998)

Essentially all tests are carried out according to the schedule of IEC publication 115-8, category **LCT/UCT/56**(rated temperature range : Lower Category Temperature, Upper Category Temperature; damp heat, long term, 56 days). The testing also meets the requirements specified by EIA, EIAJ and JIS.

The tests are carried out in accordance with IEC publication 68, "Recommended basic climatic and mechanical robustness testing procedure for electronic components" and under standard atmospheric conditions according to IEC 60068-1, sub-clause 5.3. Unless otherwise specified, the following value supplied :

Temperature: 15°C to 35°C.

Relative humidity: 45% to 75%.

Air pressure: 86kPa to 106 kPa (860 mbar to 1060 mbar).

All soldering tests are performed with mildly activated flux.

TEST	PROCEDURE / TEST METHOD	REQUIREMENT
Temperature Coefficient of Resistance (T.C.R) Clause 4.8	Natural resistance change per change in degree centigrade. $\frac{R_2 - R_1}{R_1(t_2 - t_1)} \times 10^6 \text{ (ppm/}^\circ\text{C)}$ t1 : 20°C+5°C-1°C R1 : Resistance at reference temperature R2 : Resistance at test temperature	Refer to "QUICK REFERENCE DATA"
Short time overload (S.T.O.L) Clause 4.13	Permanent resistance change after a 5second application of a voltage 2.5 times RCWV or the maximum overload voltage specified in the above list, whichever is less.	$\Delta R/R$ max. $\pm(2\%+0.005\Omega)$ WW04X max $\pm(2\%+0.010\Omega)$
Resistance to solderingheat(R.S.H) Clause 4.18	Un-mounted chips completely immersed for 10±1 second in aSAC solder bath at 260°C±5°C	no visible damage $\Delta R/R$ max. $\pm(1\%+0.005\Omega)$ WW04X max $\pm(1\%+0.010\Omega)$
Solderability Clause 4.17	Un-mounted chips completely immersed for 2±0.5 second in aSAC solder bath at 235°C±5°C	good tinning (>95% covered) no visible damage
Temperature cycling Clause 4.19	30 minutes at -55°C±3°C, 2~3 minutes at 20°C+5°C-1°C, 30 minutes at +155°C±3°C, 2~3 minutes at 20°C+5°C-1°C, total 5continuous cycles	no visible damage $\Delta R/R$ max. $\pm(1\%+0.005\Omega)$ WW04X max $\pm(1\%+0.010\Omega)$
Load life (endurance) Clause 4.25	1000 +48/-0 hours, loaded with RCWV or Vmax in chambercontroller 70±2°C, 1.5 hours on and 0.5 hours off	$\Delta R/R$ max. $\pm(3\%+0.005\Omega)$ WW04X max $\pm(5\%+0.010\Omega)$
Load life in Humidity Clause 4.24	1000 +48/-0 hours, loaded with RCWV or Vmax in humidity chamber controller at 40°C±2°C and 90~95% relative humidity, 1.5hours on and 0.5 hours off	$\Delta R/R$ max. $\pm(3\%+0.005\Omega)$ WW04X max $\pm(5\%+0.010\Omega)$
Bending strength Clause 4.33	Resistors mounted on a 90mm glass epoxy resin PCB(FR4);bending : 2 mm, once for 10 seconds	$\Delta R/R$ max. $\pm(1\%+0.005\Omega)$ WW04X max $\pm(1\%+0.010\Omega)$
Adhesion Clause 4.32	Pressurizing force: 5N, Test time: 10±1sec.	No remarkable damage or removal of the terminations
Insulation Resistance Clause 4.6	Apply the maximum overload voltage (DC) for 1minute	$R \geq 10G\Omega$
Dielectric Withstand Voltage Clause 4.7	Apply the maximum overload voltage (AC) for 1 minute	No breakdown or flashover

PACKAGING

Tape specifications (unit :mm)

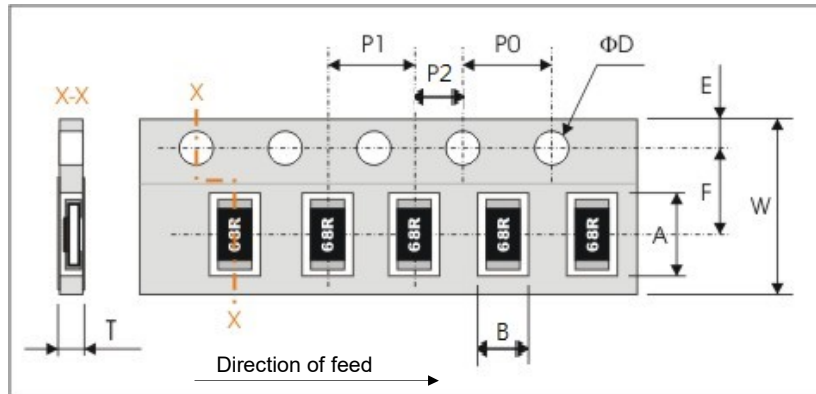

Series No.	A	B	W	F	E
WW12X	3.60±0.20	2.00±0.20	8.00±0.30	3.50±0.20	1.75±0.10
WW08X	2.40±0.20	1.65±0.20			
WW06X	1.90±0.20	1.10±0.20			
WW04X	1.20±0.10	0.70±0.10			

Series No.	P1	P0	P2	ΦD	T
WW12X / WW08X	4.00±0.10	4.00±0.10	2.00±0.10	Φ1.50 ^{+0.1} _{-0.0}	0.80±0.1
WW06X					0.70±0.05
WW04X	2.00±0.10	4.00±0.10	0.50±0.05		

Reel dimensions (unit :mm)

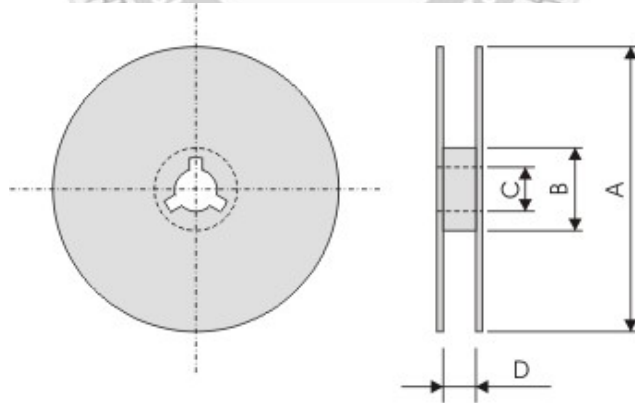

Symbol	A	B	C	D
7" Reel	Φ178.0±2.0	Φ60.0±1.0	13.0±0.2	9.0±0.5
10" Reel	Φ254.0±2.0	Φ100.0±1.0	13.0±0.2	9.0±0.5
13" Reel	Φ330.0±2.0	Φ100.0±1.0	13.0±0.2	9.0±0.5

Looking for pricing, stock, or lifecycle information?

Click below to explore more details on WIN SOURCE:

- ⊖ [View WW12XR430FTL on WIN SOURCE](#)
- ⊖ [Walsin Technology Corporation Information](#)

Optimize Your Supply Chain with WIN SOURCE Solutions

- ✓ Global Sourcing Solution
- ✓ Obsolete Management
- ✓ Cost Control Management
- ✓ Shortage Management
- ✓ Alternative Solution
- ✓ Excess Inventory Management