



**THE DATASHEET OF
TPS92623QPWPRQ1**



TPS92623-Q1 Three-Channel, Automotive High Side LED Driver with Thermal Sharing Control

1 Features

- AEC-Q100 qualified for automotive applications:
 - Temperature grade 1: -40°C to 125°C , T_A
- Wide input voltage range: 4.5 V to 40 V
- Thermal sharing by external shunt resistor
- Low supply current in fault mode
- Three high-precision current regulation:
 - Up to 150-mA current output for each channel
 - $\pm 5\%$ accuracy over full temperature range
 - Independent current setting by resistor
 - Independent PWM pin for brightness control
- Low dropout voltage:
 - Maximum dropout: 600 mV for 150 mA
- Diagnostics and protection
 - LED open-circuit with auto-recovery
 - LED short-to-GND with auto-recovery
 - Diagnostic enable with adjustable threshold
 - Fault bus configurable as either one-fails–all-fail or only-failed-channel off (N-1)
 - Thermal shutdown
- Operation junction temperature range: -40°C to 150°C

2 Applications

- **Automotive exterior rear light:** rear lamp, center high mounted stop lamp, side marker
- **Automotive exterior small light:** door handle, blind spot detection indicator, charging inlet
- **Automotive interior light:** overhead console, reading lamp
- General-purpose LED driver applications

3 Description

The TPS92623-Q1 three-channel LED driver includes a unique thermal management design to reduce temperature rising on the device. The TPS92623-Q1 is a linear driver directly powered by automotive batteries with large voltage variations to output full current loads up to 150 mA per channel. External shunt resistors are leveraged to share output current and dissipate power out of the driver. The device's full-diagnostic capabilities include LED open, LED short-to-GND circuit and device overtemperature protection.

The one-fails–all-fail feature of TPS92623-Q1 is able to work together with other LED drivers, such as the TPS9261x-Q1, TPS9262x-Q1, TPS92630/8-Q1, and TPS92830-Q1 devices, to address different requirements.

Table 3-1. Device Information

PART NUMBER	PACKAGE ⁽¹⁾	BODY SIZE (NOM)
TPS92623-Q1	HTSSOP (16)	4.40 mm × 5.00 mm

(1) For all available packages, see the orderable addendum at the end of the data sheet.

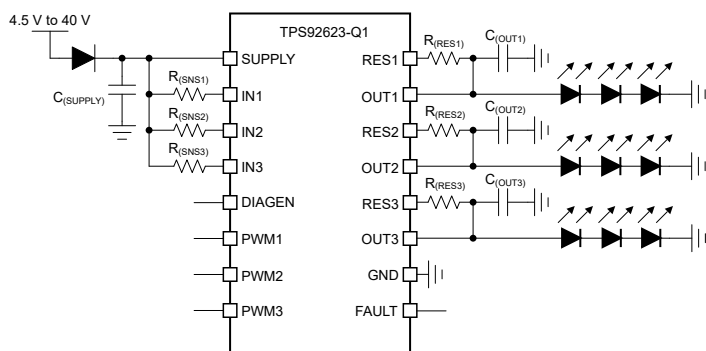

Typical Application Diagram

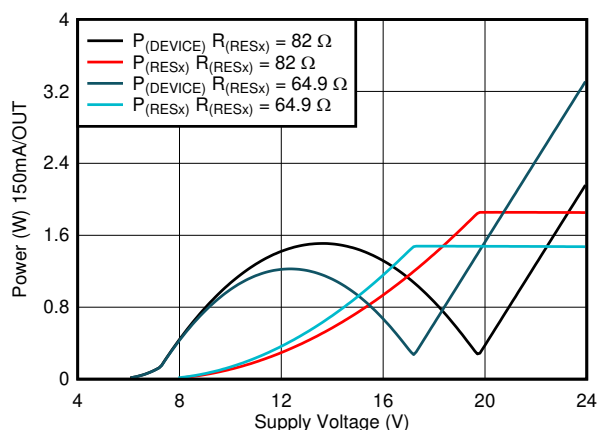

Power Dissipation on Device



Table of Contents

1 Features	1	7.4 Device Functional Modes.....	21
2 Applications	1	8 Application and Implementation	22
3 Description	1	8.1 Application Information.....	22
4 Revision History	2	8.2 Typical Applications.....	22
5 Pin Configuration and Functions	3	9 Power Supply Recommendations	27
6 Specifications	4	10 Layout	28
6.1 Absolute Maximum Ratings.....	4	10.1 Layout Guidelines.....	28
6.2 ESD Ratings.....	4	10.2 Layout Example.....	28
6.3 Recommended Operating Conditions.....	4	11 Device and Documentation Support	29
6.4 Thermal Information.....	4	11.1 Receiving Notification of Documentation Updates..	29
6.5 Electrical Characteristics.....	5	11.2 Support Resources.....	29
6.6 Typical Characteristics.....	7	11.3 Trademarks.....	29
7 Detailed Description	11	11.4 Electrostatic Discharge Caution.....	29
7.1 Overview.....	11	11.5 Glossary.....	29
7.2 Functional Block Diagram.....	11	12 Mechanical, Packaging, and Orderable Information	30
7.3 Feature Description.....	11		

4 Revision History

NOTE: Page numbers for previous revisions may differ from page numbers in the current version.

Changes from Revision * (December 2021) to Revision A (June 2022)	Page
• Changed status from "Advance Information" to "Production Data".....	1

5 Pin Configuration and Functions

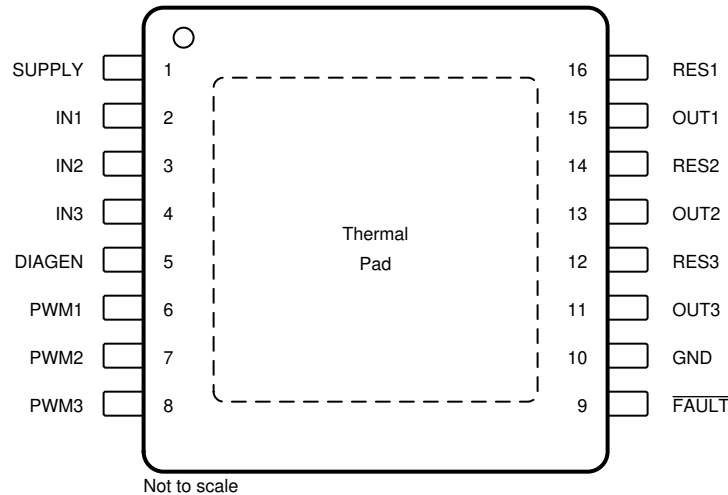

Figure 5-1. PWP Package 16-Pin HTSSOP With PowerPAD™ Top View

Table 5-1. Pin Functions

PIN		I/O	DESCRIPTION
NAME	NO.		
SUPPLY	1	I	Device power supply
IN1	2	I	Current input for channel 1
IN2	3	I	Current input for channel 2
IN3	4	I	Current input for channel 3
DIAGEN	5	I	Enable pin for LED open-circuit detection to avoid false open diagnostics during low-dropout operation.
PWM1	6	I	PWM input for OUT1 and RES1 current output ON and OFF control
PWM2	7	I	PWM input for OUT2 and RES2 current output ON and OFF control
PWM3	8	I	PWM input for OUT3 and RES3 current output ON and OFF control
FAULT	9	I/O	Fault output, support one-fails–all-fail fault bus
GND	10	—	Ground
OUT3	11	O	Current output for channel 3
RES3	12	O	Current output for channel 3 with external thermal resistor
OUT2	13	O	Current output for channel 2
RES2	14	O	Current output for channel 2 with external thermal resistor
OUT1	15	O	Current output for channel 1
RES1	16	O	Current output for channel 1 with external thermal resistor

6 Specifications

6.1 Absolute Maximum Ratings

over operating free-air temperature range (unless otherwise noted)⁽¹⁾

		MIN	MAX	UNIT
Supply	SUPPLY	-0.3	45	V
High-voltage input	DIAGEN, IN1, IN2, IN3, PWM1, PWM2, PWM3	-0.3	$V_{(SUPPLY)}+0.3$	V
High-voltage output	OUT1, OUT2, OUT3, RES1, RES2, RES3	-0.3	$V_{(SUPPLY)}+0.3$	V
Fault bus	FAULT	-0.3	$V_{(SUPPLY)}+0.3$	V
T _J	Operating junction temperature	-40	150	°C
T _{stg}	Storage temperature	-40	150	°C

- (1) Operation outside the Absolute Maximum Ratings may cause permanent device damage. Absolute Maximum Ratings do not imply functional operation of the device at these or any other conditions beyond those listed under Recommended Operating Conditions. If used outside the Recommended Operating Conditions but within the Absolute Maximum Ratings, the device may not be fully functional, and this may affect device reliability, functionality, performance, and shorten the device lifetime.

6.2 ESD Ratings

			VALUE	UNIT	
V _(ESD)	Electrostatic discharge	Human-body model (HBM), per AEC Q100-002 ⁽¹⁾ HBM ESD Classification Level 1C	±2000	V	
		Charged-device model (CDM), per AEC Q100-011 CDM ESD Classification Level C4B	All pins		±500
			Corner pins (SUPPLY, RES1, FAULT, PWM3,)		±750

- (1) AEC Q100-002 indicates that HBM stressing shall be in accordance with the ANSI/ESDA/JEDEC JS-001 specification.

6.3 Recommended Operating Conditions

over operating free-air temperature range (unless otherwise noted)

		MIN	NOM	MAX	UNIT
SUPPLY	Device supply voltage	4.5		40	V
IN1, IN2, IN3	Sense voltage	$V_{(SUPPLY)} - V_{(CS_REG)}$			V
PWM1, PWM2, PWM3	PWM inputs	0		$V_{(SUPPLY)}$	V
DIAGEN	Diagnostics enable pin	0		$V_{(SUPPLY)}$	V
OUT1, OUT2, OUT3, RES1, RES2, RES3	Driver output	0		$V_{(SUPPLY)}$	V
FAULT	Fault bus	0		$V_{(SUPPLY)}$	V
Operating ambient temperature, T _A		-40		125	°C

6.4 Thermal Information

THERMAL METRIC ⁽¹⁾		TPS92623-Q1	UNIT
		PWP	
		16 PINS	
R _{θJA}	Junction-to-ambient thermal resistance	46.3	°C/W
R _{θJC(top)}	Junction-to-case (top) thermal resistance	41.9	°C/W
R _{θJB}	Junction-to-board thermal resistance	22.8	°C/W
ψ _{JT}	Junction-to-top characterization parameter	1.4	°C/W
ψ _{JB}	Junction-to-board characterization parameter	22.8	°C/W
R _{θJC(bot)}	Junction-to-case (bottom) thermal resistance	6.1	°C/W

- (1) For more information about traditional and new thermal metrics, see the [Semiconductor and IC package thermal metrics application report](#).

6.5 Electrical Characteristics

$V_{(SUPPLY)} = 5\text{ V to }40\text{ V}$, $V_{(EN)} = 5\text{ V}$, $T_J = -40^\circ\text{C to }+150^\circ\text{C}$ unless otherwise noted

PARAMETER		TEST CONDITIONS	MIN	TYP	MAX	UNIT
BIAS						
$V_{(POR_rising)}$	Supply voltage POR rising threshold			3.6	4.0	V
$V_{(POR_falling)}$	Supply voltage POR falling threshold		3.0	3.4		V
$I_{(Quiescent)}$	Device standby ground current	PWM = HIGH		1.6	2.5	mA
$I_{(FAULT)}$	Device supply current in fault mode	PWM = HIGH, FAULT externally pulled LOW	0.21	0.350	0.45	mA
LOGIC INPUTS (DIAGEN, PWM)						
$V_{(IL(DIAGEN))}$	Input logic-low voltage, DIAGEN		1.045	1.1	1.155	V
$V_{(IH(DIAGEN))}$	Input logic-high voltage, DIAGEN		1.14	1.2	1.26	V
$V_{(IL(PWM))}$	Input logic-low voltage, PWM		1.045	1.1	1.155	V
$V_{(IH(PWM))}$	Input logic-high voltage, PWM		1.14	1.2	1.26	V
CONSTANT-CURRENT DRIVER						
$I_{(OUTx_Tot)}$	Device output-current for each channel	100% duty cycle		5	150	mA
$V_{(CS_REG)}$	Sense-resistor regulation voltage	$T_A = -40^\circ\text{C to }+125^\circ\text{C}$	144	150	156	mV
ALL $\Delta V_{(CS_c2c)}$	Channel to channel mismatch	$\Delta V_{(CS_c2c)} = 1 - V_{(CS_REGx)}/V_{avg(CS_REG)}$	-3		+3	%
ALL $\Delta V_{(CS_d2d)}$	Device to device mismatch	$\Delta V_{(CS_d2d)} = 1 - V_{avg(CS_REG)}/V_{nom(CS_REG)}$	-4		+4	%
$R_{(CS_REG)}$	Sense-resistor range		0.96		31.2	Ω
$V_{(DROPOUT)}$	Voltage dropout from INx to OUTx, RESx open	current setting of 100 mA		200	400	mV
		current setting of 150 mA		300	600	
	Voltage dropout from INx to RESx, OUTx open	current setting of 100 mA		280	600	mV
		current setting of 150 mA		400	900	
$I_{(RESx)}$	Ratio of RESx current to total current	$I_{(RESx)}/I_{(OUTx_Tot)}$, $V_{(INx)} - V_{(RESx)} > 1\text{ V}$	95			%
DIAGNOSTICS						
$V_{(OPEN_th_rising)}$	LED open rising threshold, $V_{(IN)} - V_{(OUT)}$		180	300	420	mV
$V_{(OPEN_th_falling)}$	LED open falling threshold, $V_{(IN)} - V_{(OUT)}$			450		mV
$V_{(SG_th_rising)}$	Channel output short-to-ground rising threshold		1.14	1.2	1.26	V
$V_{(SG_th_falling)}$	Channel output short-to-ground falling threshold		0.855	0.9	0.945	V
$I_{(Retry_OUTx)}$	Channel output $V_{(OUT)}$ short-to-ground retry current		0.64	1.08	1.528	mA
$I_{(Retry_RESx)}$	Channel output $V_{(OUT)}$ short-to-ground retry current		0.64	1.08	1.528	mA
FAULT						
$V_{(IL(FAULT))}$	Logic input low threshold				0.7	V
$V_{(IH(FAULT))}$	Logic input high threshold		2			V
$t_{(FAULT_rising)}$	Fault detection rising edge deglitch time			10		μs
$t_{(FAULT_falling)}$	Fault detection falling edge deglitch time			20		μs
$I_{(FAULT_pulldown)}$	FAULT internal pulldown current	$V_{(FAULT)} = 0.4\text{ V}$	2	3	4	mA
$I_{(FAULT_pullup)}$	FAULT internal pullup current		6	10	14	μA
$I_{(FAULT_leakage)}$	FAULT leakage current	$V_{(FAULT)} = 20\text{ V}$		0.01	2	μA
TIMING						
$t_{(PWM_delay_rising)}$	PWM rising edge delay to 10% of output current, t_1 as shown in Figure 7-1	$V_{(SUPPLY)} = 12\text{ V}$, $V_{(OUT)} = 6\text{ V}$, $V_{(CS_REG)} = 150\text{ mV}$, $R_{(SNSx)} = 1\ \Omega$ and $R_{(RESx)} = 56\ \Omega$		3		μs
		$V_{(SUPPLY)} = 12\text{ V}$, $V_{(OUT)} = 6\text{ V}$, $V_{(CS_REG)} = 150\text{ mV}$, $R_{(SNSx)} = 30\ \Omega$ and $R_{(RESx)} = 56\ \Omega$		3		μs
$t_{(PWM_delay_falling)}$	PWM falling edge delay to 90% of output current, t_2 as shown in Figure 7-1	$V_{(SUPPLY)} = 12\text{ V}$, $V_{(OUT)} = 6\text{ V}$, $V_{(CS_REG)} = 150\text{ mV}$, $R_{(SNSx)} = 1\ \Omega$ and $R_{(RESx)} = 56\ \Omega$		3.8		μs
		$V_{(SUPPLY)} = 12\text{ V}$, $V_{(OUT)} = 6\text{ V}$, $V_{(CS_REG)} = 150\text{ mV}$, $R_{(SNSx)} = 30\ \Omega$ and $R_{(RESx)} = 56\ \Omega$		3.8		μs
$t_{(Current_rising)}$	Output current rising from 10% to 90%, t_3 as shown in Figure 7-1	$V_{(SUPPLY)} = 12\text{ V}$, $V_{(OUT)} = 6\text{ V}$, $V_{(CS_REG)} = 150\text{ mV}$, $R_{(SNSx)} = 1\ \Omega$ and $R_{(RESx)} = 56\ \Omega$		2		μs
		$V_{(SUPPLY)} = 12\text{ V}$, $V_{(OUT)} = 6\text{ V}$, $V_{(CS_REG)} = 150\text{ mV}$, $R_{(SNSx)} = 30\ \Omega$ and $R_{(RESx)} = 56\ \Omega$		1		μs

6.5 Electrical Characteristics (continued)

 $V_{(SUPPLY)} = 5\text{ V to }40\text{ V}$, $V_{(EN)} = 5\text{ V}$, $T_J = -40^\circ\text{C to }+150^\circ\text{C}$ unless otherwise noted

PARAMETER		TEST CONDITIONS	MIN	TYP	MAX	UNIT
$t_{(Current_falling)}$	Output current falling from 90% to 10%, t_4 as shown in Figure 7-1	$V_{(SUPPLY)} = 12\text{ V}$, $V_{(OUT)} = 6\text{ V}$, $V_{(CS_REG)} = 150\text{ mV}$, $R_{(SNSx)} = 1\ \Omega$ and $R_{(RESx)} = 56\ \Omega$		5		μs
		$V_{(SUPPLY)} = 12\text{ V}$, $V_{(OUT)} = 6\text{ V}$, $V_{(CS_REG)} = 150\text{ mV}$, $R_{(SNSx)} = 30\ \Omega$ and $R_{(RESx)} = 56\ \Omega$		0.2		μs
$t_{(STARTUP)}$	SUPPLY rising edge to 10% output current, t_5 as shown in Figure 7-1	$V_{(SUPPLY)} = 12\text{ V}$, $V_{(OUT)} = 6\text{ V}$, $V_{(CS_REG)} = 150\text{ mV}$, $R_{(SNSx)} = 1\ \Omega$ and $R_{(RESx)} = 56\ \Omega$		85		μs
$t_{(OPEN_deg)}$	LED-open fault detection deglitch time, t_6 as shown in Figure 7-4			125		μs
$t_{(SG_deg)}$	Output short-to-ground detection deglitch time, t_7 as shown in Figure 7-3			125		μs
$t_{(Recover_deg)}$	Open and Short fault recovery deglitch time, t_8 as shown in Figure 7-3 and Figure 7-4			125		μs
$t_{(FAULT_recovery)}$	Fault recovery delay time, t_9 as shown in Figure 7-3 and Figure 7-4			50		μs
$t_{(TSD_deg)}$	Thermal over temperature deglitch time			50		μs
THERMAL PROTECTION						
$T_{(TSD)}$	Thermal shutdown junction temperature threshold		157	172	187	$^\circ\text{C}$
$T_{(TSD_HYS)}$	Thermal shutdown junction temperature hysteresis			15		$^\circ\text{C}$

6.6 Typical Characteristics

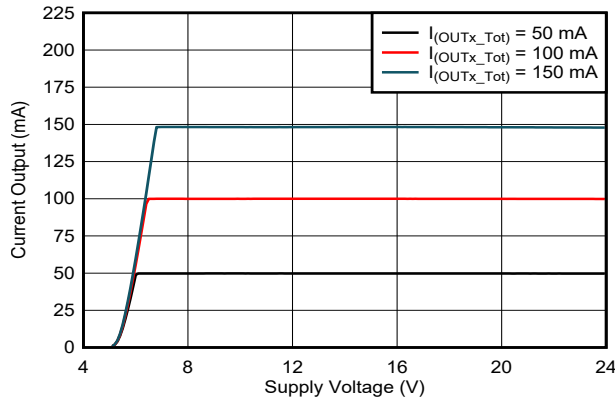

Figure 6-1. Output Current vs Supply Voltage

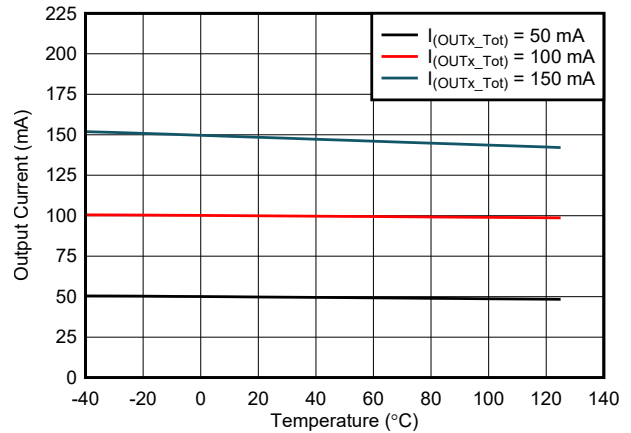

Figure 6-2. Output Current vs Temperature

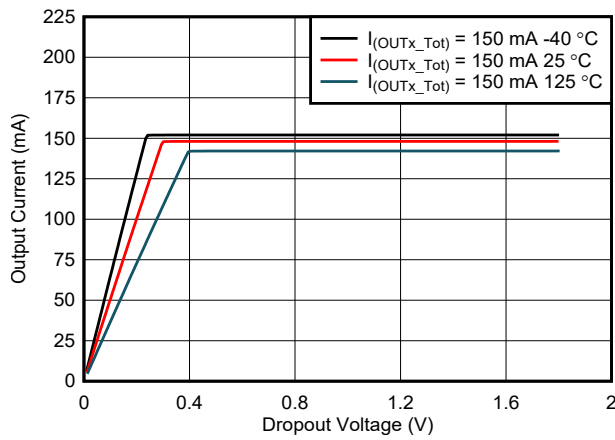

Figure 6-3. Output Current vs Dropout Voltage

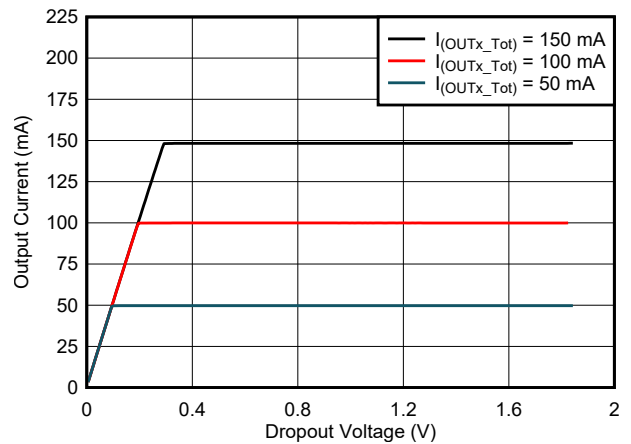

Figure 6-4. Output Current vs Dropout Voltage

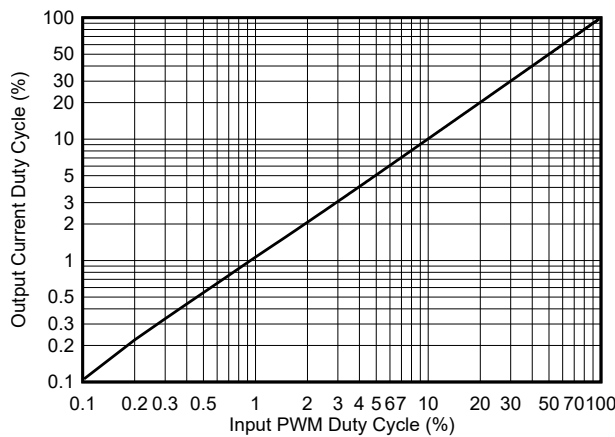

Figure 6-5. PWM Output Duty Cycle vs PWM Input Duty Cycle

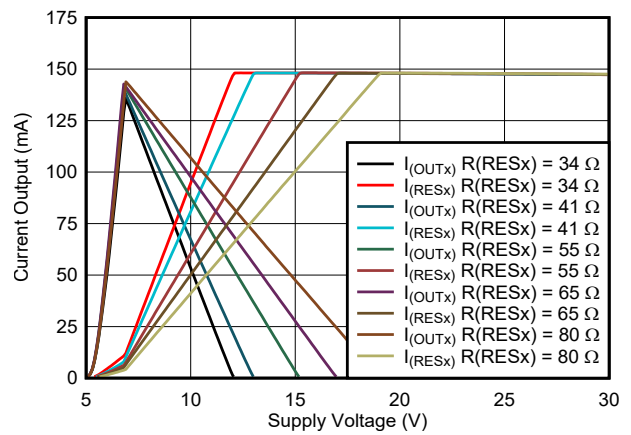

Figure 6-6. Output Current Distribution vs Supply Voltage

6.6 Typical Characteristics (continued)

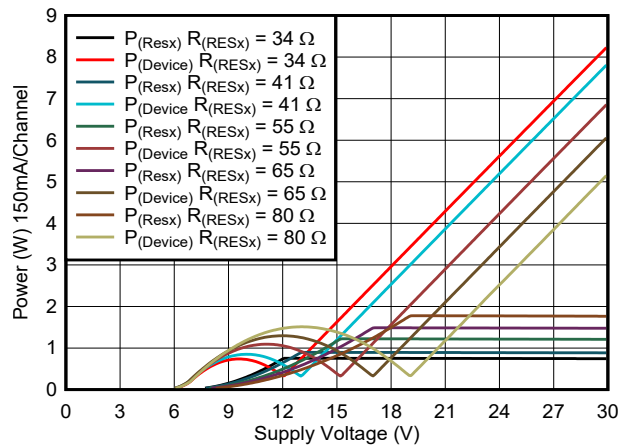

Figure 6-7. Power Dissipation vs Supply Voltage

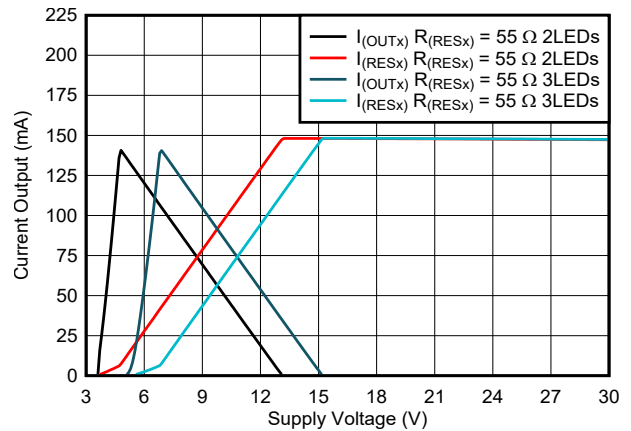

Figure 6-8. Output Current Distribution vs Supply Voltage

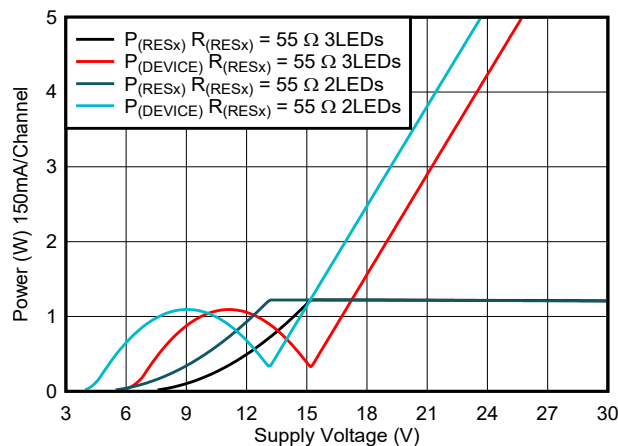
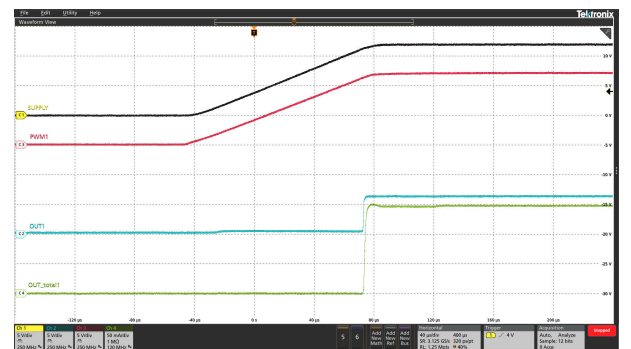
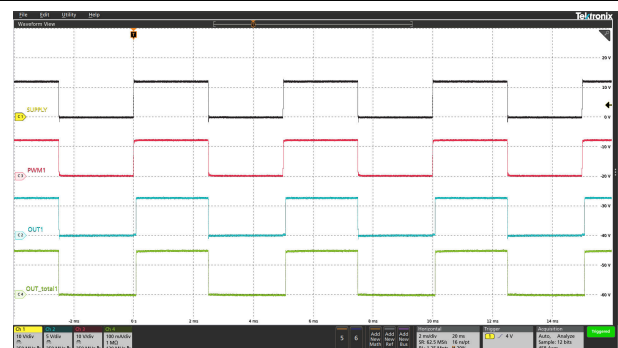

Figure 6-9. Power Dissipation vs Supply Voltage



Ch1 = $V_{(SUPPLY)}$ Ch2 = $V_{(OUT1)}$ Ch3 = $V_{(PWM1)}$
Ch4 = $I_{(OUT_Tot)}$

Figure 6-10. Power Up Sequence



Ch1 = $V_{(SUPPLY)}$ Ch2 = $V_{(OUT1)}$ Ch3 = $V_{(PWM1)}$
Ch4 = $I_{(OUT_Tot)}$

Figure 6-11. Supply Dimming at 200 Hz

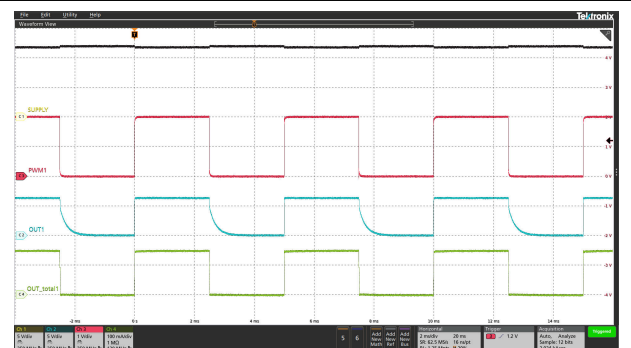

Ch1 = $V_{(SUPPLY)}$ Ch2 = $V_{(OUT1)}$ Ch3 = $V_{(PWM1)}$
Ch4 = $I_{(OUT_Tot)}$

Figure 6-12. PWM Dimming at 200 Hz

6.6 Typical Characteristics (continued)

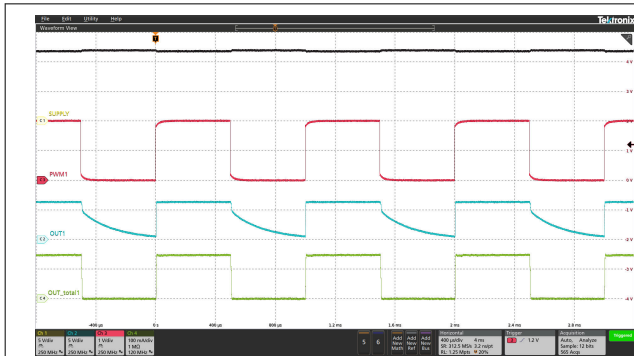

Ch1 = $V_{(SUPPLY)}$ Ch2 = $V_{(OUT1)}$ Ch3 = $V_{(PWM1)}$
 Ch4 = $I_{(OUT_Tot)}$

Figure 6-13. PWM Dimming at 1 kHz

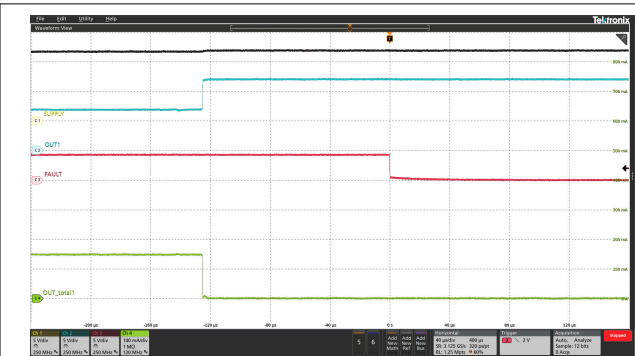

Ch1 = $V_{(SUPPLY)}$ Ch2 = $V_{(OUT1)}$ Ch3 = $V_{(FAULT)}$
 Ch4 = $I_{(OUT_Tot)}$

Figure 6-14. LED Open Protection

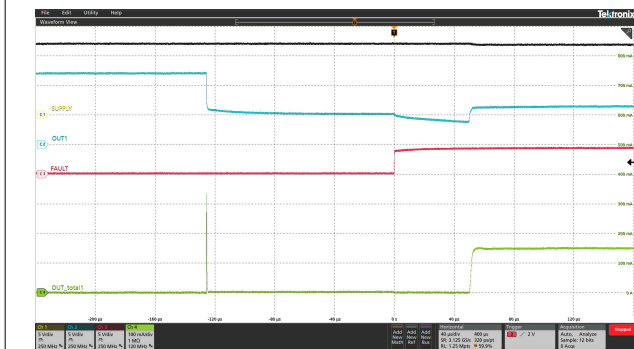

Ch1 = $V_{(SUPPLY)}$ Ch2 = $V_{(OUT1)}$ Ch3 = $V_{(FAULT)}$
 Ch4 = $I_{(OUT_Tot)}$

Figure 6-15. LED Open Protection Recovery

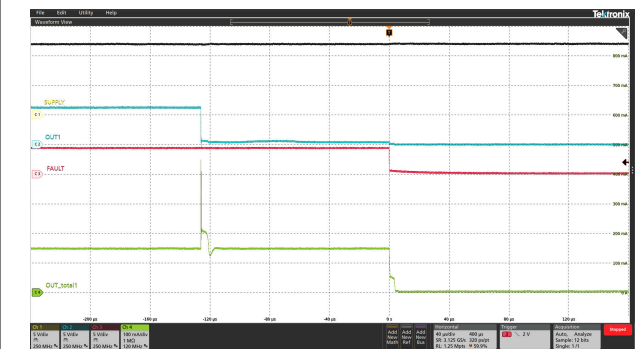

Ch1 = $V_{(SUPPLY)}$ Ch2 = $V_{(OUT1)}$ Ch3 = $V_{(FAULT)}$
 Ch4 = $I_{(OUT_Tot)}$

Figure 6-16. LED Short-Circuit Protection

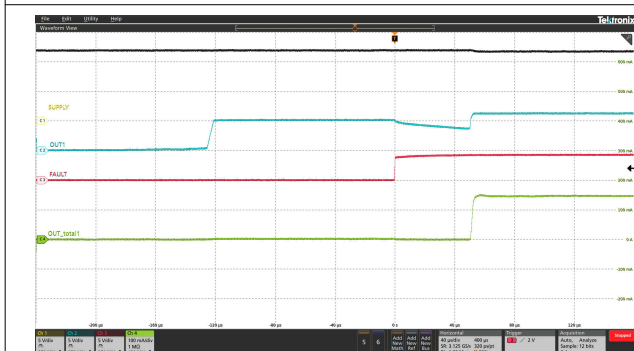

Ch1 = $V_{(SUPPLY)}$ Ch2 = $V_{(OUT1)}$ Ch3 = $V_{(FAULT)}$
 Ch4 = $I_{(OUT_Tot)}$

Figure 6-17. LED Short-Circuit Protection Recovery

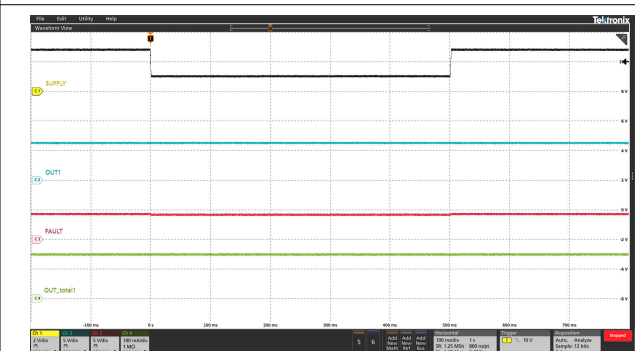

Ch1 = $V_{(SUPPLY)}$ Ch2 = $V_{(OUT1)}$ Ch3 = $V_{(FAULT)}$
 Ch4 = $I_{(OUT_Tot)}$ DIAGEN = High when Supply > 8 V

Figure 6-18. Transient Undervoltage

6.6 Typical Characteristics (continued)

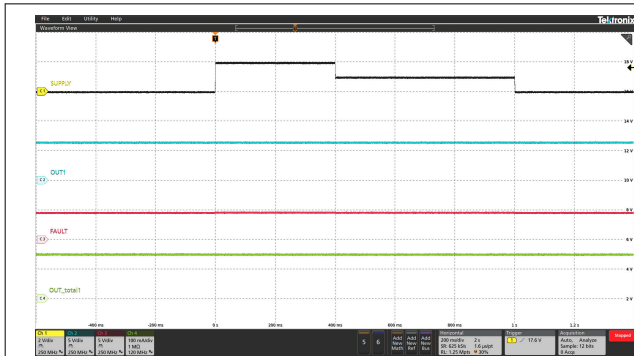

Ch1 = $V_{(SUPPLY)}$ Ch2 = $V_{(OUT1)}$ Ch3 = $V_{(FAULT)}$
Ch4 = $I_{(OUT_Tot)}$ DIAGEN = High when Supply > 8 V

Figure 6-19. Transient Overvoltage

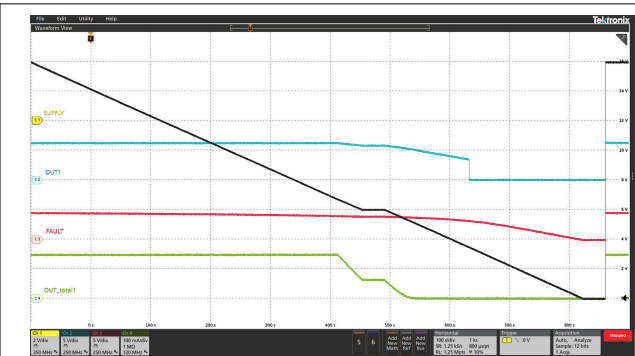

Ch1 = $V_{(SUPPLY)}$ Ch2 = $V_{(OUT1)}$ Ch3 = $V_{(FAULT)}$
Ch4 = $I_{(OUT_Tot)}$ DIAGEN = High when Supply > 8 V

Figure 6-20. Slow Decrease and Quick Increase of Supply Voltage

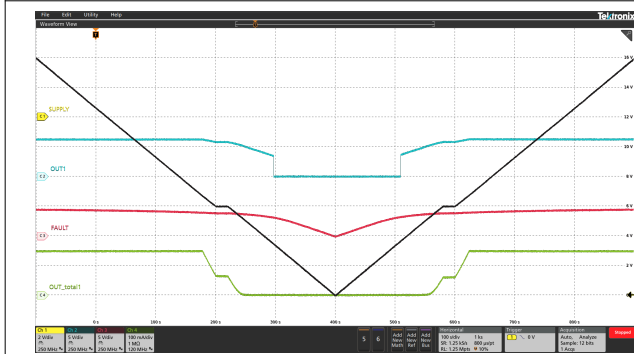

Ch1 = $V_{(SUPPLY)}$ Ch2 = $V_{(OUT1)}$ Ch3 = $V_{(FAULT)}$
Ch4 = $I_{(OUT_Tot)}$ DIAGEN = High when Supply > 8 V

Figure 6-21. Slow Decrease and Slow Increase of Supply Voltage

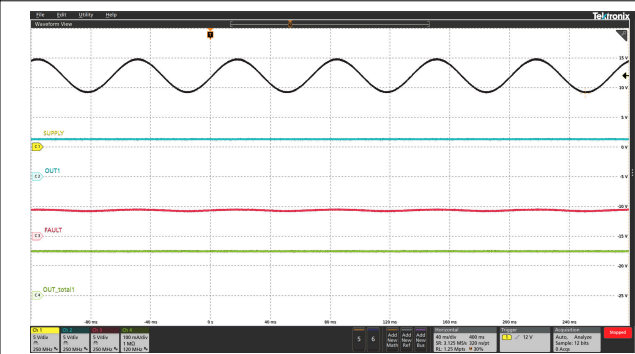

Ch1 = $V_{(SUPPLY)}$ Ch2 = $V_{(OUT1)}$ Ch3 = $V_{(FAULT)}$
Ch4 = $I_{(OUT_Tot)}$ DIAGEN = High when Supply > 8 V

Figure 6-22. Superimposed Alternating Voltage 15 Hz

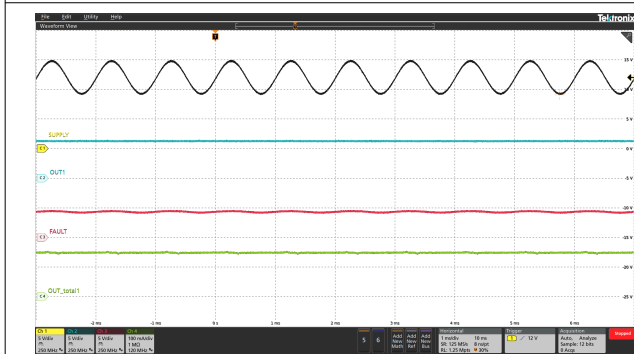

Ch1 = $V_{(SUPPLY)}$ Ch2 = $V_{(OUT1)}$ Ch3 = $V_{(FAULT)}$
Ch4 = $I_{(OUT_Tot)}$ DIAGEN = High when Supply > 8 V

Figure 6-23. Superimposed Alternating Voltage 1 kHz

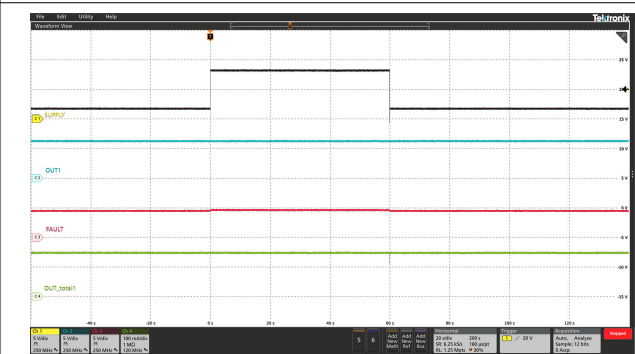

Ch1 = $V_{(SUPPLY)}$ Ch2 = $V_{(OUT1)}$ Ch3 = $V_{(FAULT)}$
Ch4 = $I_{(OUT_Tot)}$ DIAGEN = High when Supply > 8 V

Figure 6-24. Jump Start

7 Detailed Description

7.1 Overview

The TPS92623-Q1 is a three-channel, high-side linear LED driver supporting external thermal sharing resistor to achieve the controllable junction temperature rising. The device can be directly powered by automotive battery and output full load up to 450-mA current to LED with limited power dissipation on the device. The current output at each channel can be independently set by external $R_{(SNSx)}$ resistors. Current flows from the supply through the $R_{(SNSx)}$ resistor into the integrated current regulation circuit and to the LEDs through OUTx pin and RESx pin. TPS92623-Q1 device supports both supply control and PWM control to turn LED ON and OFF. The LED brightness is also adjustable by voltage duty cycle applied on either SUPPLY or PWMx pins with frequency above 100 Hz. The TPS92623-Q1 provides full diagnostics to keep the system operating reliably including LED open/short circuit detection, supply POR and thermal shutdown protection. TPS92623-Q1 device is in a HTSSOP package with total 16 leads. The TPS92623-Q1 can be used with other TPS9261x-Q1, TPS9262x-Q1, TPS9263x-Q1 and TPS92830-Q1 family devices together to achieve one-fails-all-fail protection by tying all $\overline{\text{FAULT}}$ pins together as a fault bus.

7.2 Functional Block Diagram

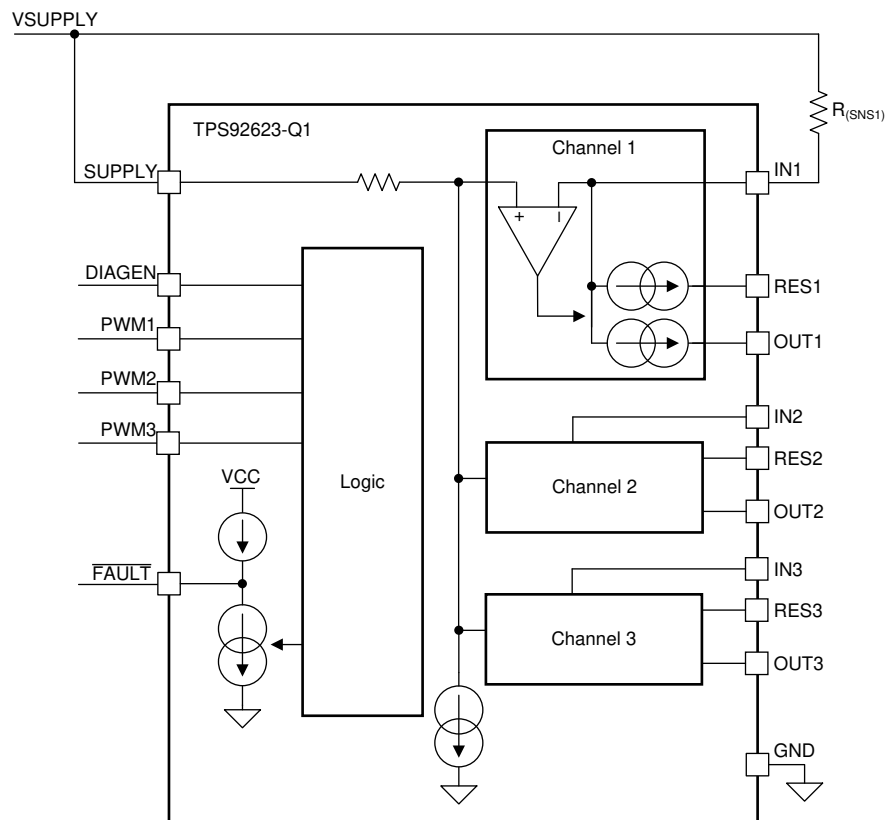

7.3 Feature Description

7.3.1 Power Supply (SUPPLY)

7.3.1.1 Power-On Reset (POR)

The TPS92623-Q1 device has an internal power-on-reset (POR) function. When power is applied to the SUPPLY pin, the internal POR circuit holds the device in reset state until $V_{(SUPPLY)}$ is above $V_{(POR_rising)}$.

7.3.1.2 Supply Current in Fault Mode

The TPS92623-Q1 device consumes minimal quiescent current, $I_{(FAULT)}$, into SUPPLY when the $\overline{\text{FAULT}}$ pin is externally pulled LOW. At the same time, the device shuts down all three output drivers.

If device detects an internal fault, it pulls down the $\overline{\text{FAULT}}$ pin by an internal typical 3-mA constant current as a fault indication to the fault bus.

7.3.2 Enable and Shutdown

The device starts to operate as long as the SUPPLY voltage is higher than $V_{(\text{POR_rising})}$. The TPS92623-Q1 shuts down when SUPPLY voltage is lower than $V_{(\text{POR_falling})}$.

7.3.3 Constant-Current Output and Setting (INx)

The TPS92623-Q1 device is a high-side current driver for driving LEDs. The device controls each output current through regulating the voltage drop on an external high-side current-sense resistor, $R_{(\text{SNSx})}$ independently for each channel. An integrated error amplifier drives an internal power transistor to maintain the voltage drop on the current-sense resistor $R_{(\text{SNSx})}$ to $V_{(\text{CS_REG})}$ and therefore regulates the current output to target value. When the output current is in regulation, the current value for each channel can be calculated by using [Equation 1](#).

$$I_{(\text{OUTx_Tot})} = \frac{V_{(\text{CS_REG})}}{R_{(\text{SNSx})}} \quad (1)$$

where

- $V_{(\text{CS_REG})} = 150 \text{ mV}$
- $x = 1, 2 \text{ or } 3$ for output channel 1, 2 or 3

When the supply voltage drops below total LED string forward voltage plus required headroom voltage, the sum of $V_{(\text{DROPOUT})}$ and $V_{(\text{CS_REG})}$, the TPS92623-Q1 is not able to deliver enough current output as set by the value of $R_{(\text{SNSx})}$, and the voltage across the current-sense resistor $R_{(\text{SNSx})}$ is less than $V_{(\text{CS_REG})}$.

7.3.4 Thermal Sharing Resistor (OUTx and RESx)

The TPS92623-Q1 device provides two current output paths for each channel. Current flows from the supply through the $R_{(\text{SNSx})}$ resistor into the integrated current regulation circuit and to the LEDs through OUTx pin and RESx pin. The current output on both OUTx pin and RESx pin is independently regulated to achieve total required current output. The summed current of OUTx and RESx is equal to the current through the $R_{(\text{SNSx})}$ resistor in the channel. The OUTx connects to anode of LEDs load in serial directly, however RESx connects to the LEDs through an external resistor to share part of the power dissipation and reduce the thermal accumulation in TPS92623-Q1.

The integrated independent current regulation in TPS92623-Q1 dynamically adjusts the output current on both OUTx and RESx output to maintain the stable summed current for LED. The TPS92623-Q1 always regulates the current output to the RESx pin as much as possible until the RESx current path is saturated, and the rest of required current is regulated out of the OUTx. As a result, the most of the current to LED outputs through the RESx pin when the voltage dropout is large between SUPPLY and LED required total forward voltage. In the opposite case, the most of the current to LED outputs through the OUTx pin when the voltage headroom is relative low between SUPPLY and LED required forward voltage.

7.3.5 PWM Control (PWMx)

The pulse width modulation (PWM) input of the TPS92623-Q1 functions as enable for the output current. When the voltage applied on the PWM pin is higher than $V_{(\text{IH}(\text{PWM}))}$, the relevant output current is enabled. When the voltage applied on PWM pin is lower than $V_{(\text{IL}(\text{PWM}))}$, the output current is disabled as well as the diagnostic features. Besides output current enable and disable function, the PWM input of TPS92623-Q1 also supports adjustment of the average current output for brightness control if the frequency of applied PWM signal is higher than 100 Hz, which is out of visible frequency range of human eyes. TI recommends a 200-Hz PWM signal with 1% to 100% duty cycle input for brightness control. Please refer to [Figure 8-4](#) for typical PWM dimming application.

The TPS92623-Q1 device has three PWM input pins: PWM1, PWM2, and PWM3 to control each of current output channel independently. PWM1 input controls the output channel1 for both OUT1 and RES1, PWM2 input

controls the output channel2 for both OUT2 and RES2, and PWM3 input controls the output channel3 for both OUT3 and RES3. Figure 7-1 illustrates the timing for PWM input and current output.

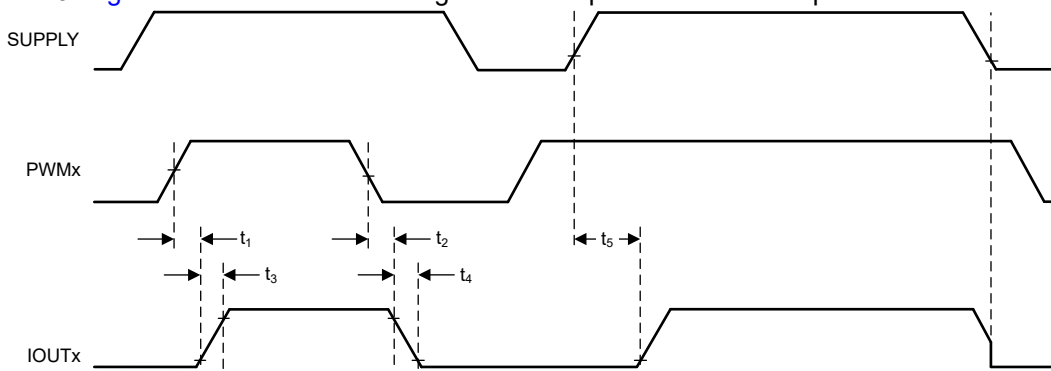

Figure 7-1. Power On Sequence and PWM Dimming Timing

The detailed information and value of each time period in Figure 7-1 is described in [Electrical Characteristics](#).

7.3.6 Supply Control

The TPS92623-Q1 can support supply control to turn ON and OFF output current. When the voltage applied on the SUPPLY pin is higher than the LED string forward voltage plus needed headroom voltage at required current, and the PWM pin voltage is high, the output current is turned ON and well regulated. However, if the voltage applied on the SUPPLY pin is lower than $V_{(POR_falling)}$, the output current is turned OFF. With this feature, the power supply voltage in designed pattern can control the output current ON and OFF. The brightness is adjustable if the ON and OFF frequency is fast enough. Because of the high accuracy design of PWM threshold in TPS92623-Q1, TI recommends a resistor divider on the PWM pin to set the SUPPLY threshold higher than LED forward voltage plus required headroom voltage as shown in Figure 7-2. The headroom voltage is basically the summation of $V_{(DROPOUT)}$ and $V_{(CS_REG)}$. When the voltage on the PWM pin is higher than $V_{IH(PWM)}$, the output current is turned ON. However, when the voltage on the PWM is lower than $V_{IL(PWM)}$, the output current is turned OFF. The SUPPLY threshold voltage can be calculated by using Equation 2.

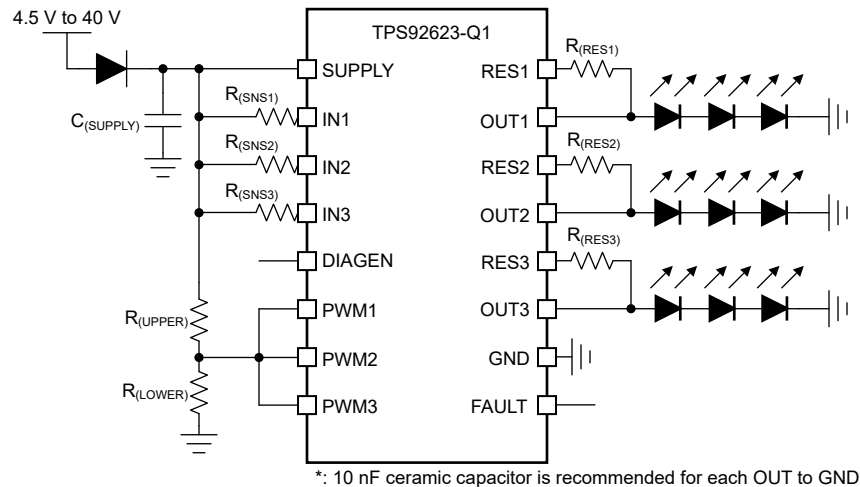

Figure 7-2. Application Schematic for Supply Control LED Brightness

$$V_{(SUPPLY_PWM_th_rising)} = V_{IH(PWM)} \times \left(1 + \frac{R_{(UPPER)}}{R_{(LOWER)}} \right) \quad (2)$$

where

- $V_{IH(PWM)} = 1.26 \text{ V}$ (maximum)

7.3.7 Diagnostics

The TPS92623-Q1 device provides advanced diagnostics and fault-protection features for automotive exterior lighting systems. The device is able to detect and protect fault from LED-string short-to-GND, LED-string open-circuit and junction over-temperature scenarios. The device also supports a one-fails-all-fail fault bus design that can flexibly fit different regulatory requirements.

7.3.7.1 LED Short-to-GND Detection

The TPS92623-Q1 device has LED short-to-GND detection. The LED short-to-GND detection monitors the output voltage when the output current is enabled. Once a short-to-GND LED failure is detected, the device turns off the faulty channel and retries automatically, regardless of the state of the PWM input. If the retry mechanism detects the removal of the LED short-to-GND fault, the device resumes to normal operation.

The TPS92623-Q1 monitors both $V_{(OUTx)}$ voltage and $V_{(RESx)}$ voltage of each channel and compares it with the internal reference voltage to detect a short-to-GND failure. If $V_{(OUTx)}$ or $V_{(RESx)}$ voltage falls below $V_{(SG_th_falling)}$ longer than the deglitch time of $t_{(SG_deg)}$, the device asserts the short-to-GND fault and pulls low the \overline{FAULT} pin. During the deglitching time period, if $V_{(OUTx)}$ and $V_{(RESx)}$ rises above $V_{(SG_th_rising)}$, the timer is reset.

Once the TPS92623-Q1 has asserted a short-to-GND fault, the device turns off the faulty output channel and retries automatically with a small current. During retrying, the device sources a small current $I_{(Retry)}$ from SUPPLY to OUT and RES to pull up the LED loads continuously. After auto-retry detects output voltage rising above $V_{(SG_th_rising)}$, it clears the short-to-GND fault and resumes to normal operation. Figure 7-3 illustrates the timing for LED short-circuit detection, protection, retry and recovery.

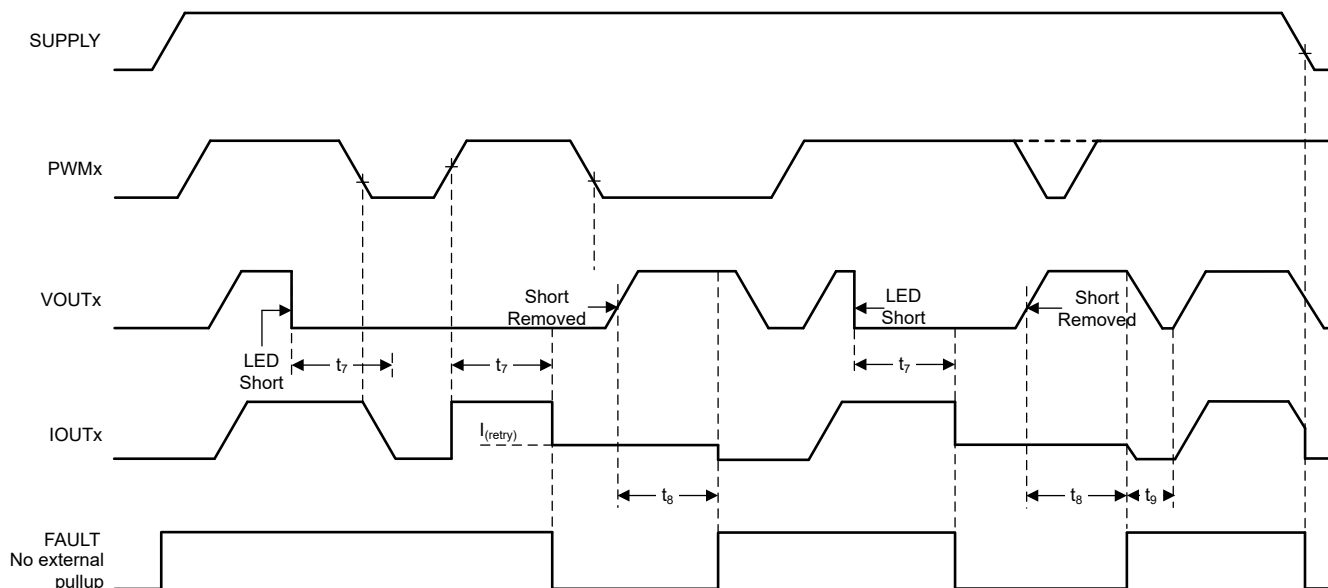

Figure 7-3. LED Short-to-GND Detection and Recovery Timing Diagram

The detailed information and value of each time period in Figure 7-3 is described in [Electrical Characteristics](#).

7.3.7.2 LED Open-Circuit Detection

The TPS92623-Q1 device has LED open-circuit detection. The LED open-circuit detection monitors the output voltage when the current output is enabled. The LED open-circuit detection is only enabled when DIAGEN is HIGH. A short-to-battery fault is also detected and recognized as an LED open-circuit fault.

The TPS92623-Q1 monitors dropout-voltage differences between the IN and OUT pins for each LED channel when PWM is HIGH. The voltage difference $V_{(INx)} - V_{(OUTx)}$ is compared with the internal reference voltage $V_{(OPEN_th_rising)}$ to detect an LED open-circuit incident. If $V_{(OUTx)}$ rises and causes $V_{(INx)} - V_{(OUTx)}$ less than the $V_{(OPEN_th_rising)}$ voltage longer than the deglitch time of $t_{(OPEN_deg)}$, the device asserts an open-circuit fault. After a LED open-circuit failure is detected, the internal constant-current sink pulls down the \overline{FAULT} pin voltage.

During the deglitch time period, if $V_{(OUTx)}$ falls and makes $V_{(INx)} - V_{(OUTx)}$ larger than $V_{(OPEN_th_falling)}$, the deglitch timer is reset.

The TPS92623-Q1 shuts down the output current regulation for the error channel after LED open-circuit fault is detected. The device sources a small current $I_{(Retry)}$ from SUPPLY to OUT and RES when DIAGEN input is logic High. After the fault condition is removed, the device resumes normal operation and releases the FAULT pin. Figure 7-4 illustrates the timing for LED open-circuit detection, protection, retry and recovery.

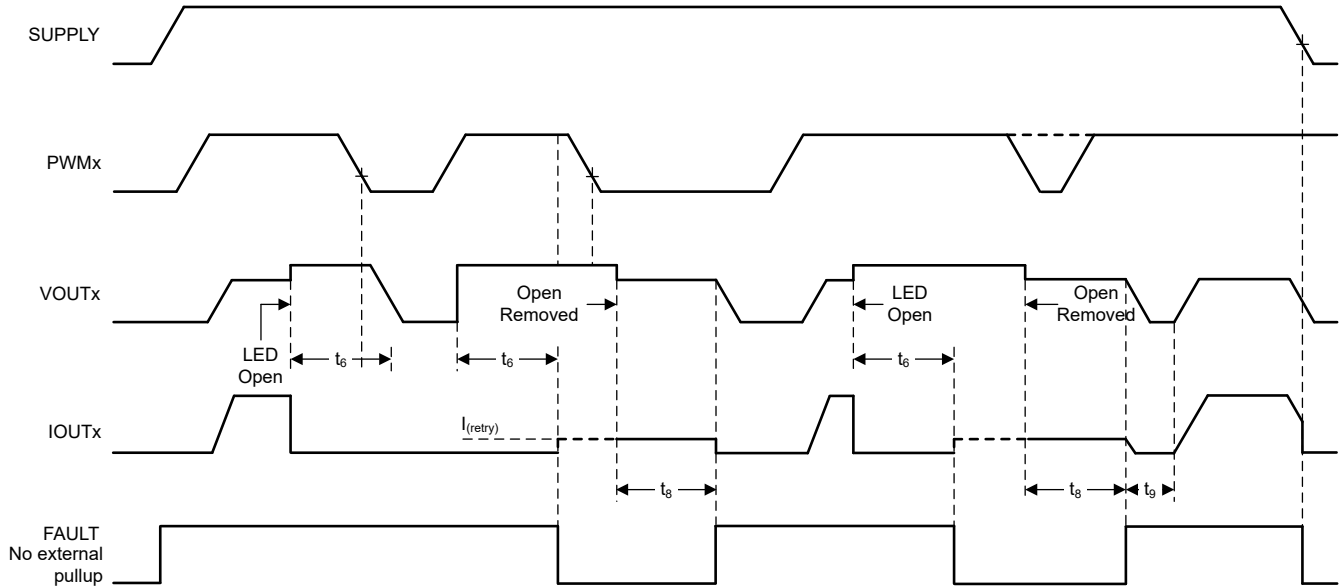

Figure 7-4. LED Open-Circuit Detection and Recovery Timing Diagram

The detailed information and value of each time period in Figure 7-4 is described in [Electrical Characteristics](#).

7.3.7.3 LED Open-Circuit Detection Enable (DIAGEN)

The TPS92623-Q1 device supports the DIAGEN pin with an accurate threshold to disable the LED open-circuit. The DIAGEN pin can be used to enable or disable LED open-circuit detection based on SUPPLY pin voltage sensed by an external resistor divider as illustrated in Figure 7-5. When the voltage applied on DIAGEN pin is higher than the threshold $V_{IH(DIAGEN)}$, the device enables LED open-circuit detection. When $V_{(DIAGEN)}$ is lower than the threshold $V_{IL(DIAGEN)}$, the device disables LED open-circuit detection.

Only LED open-circuit detection can be disabled by pulling down the DIAGEN pin. The LED short-to-GND detection and overtemperature protection cannot be turned off by pulling down the DIAGEN pin. The SUPPLY threshold voltage can be calculated by using Equation 3.

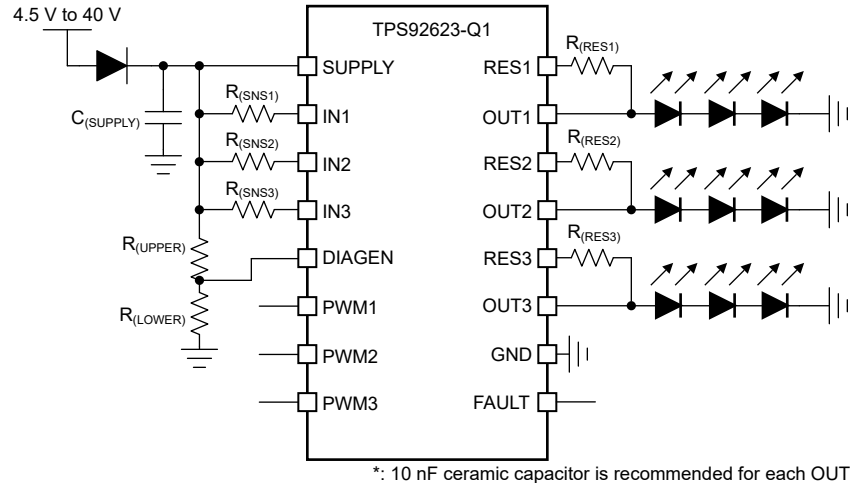

Figure 7-5. Application Schematic For DIAGEN

$$V_{(\text{SUPPLY_DIAGEN_th_falling})} = V_{\text{IL}(\text{DIAGEN})} \times \left(1 + \frac{R_{(\text{UPPER})}}{R_{(\text{LOWER})}} \right) \quad (3)$$

where

- $V_{\text{IL}(\text{DIAGEN})} = 1.045 \text{ V}$ (minimum)

7.3.7.4 Overtemperature Protection

The TPS92623-Q1 device monitors device junction temperature. When the junction temperature reaches thermal shutdown threshold $T_{(\text{TSD})}$, the output shuts down. After the junction temperature falls below $T_{(\text{TSD})} - T_{(\text{TSD_HYS})}$, the device recovers to normal operation. During overtemperature protection, the $\overline{\text{FAULT}}$ pin is pulled low.

7.3.7.5 Low Dropout Operation

When the supply voltage drops below LED string total forward voltage plus headroom voltage at required current, the TPS92623-Q1 device operates in low-dropout conditions to deliver current output as close as possible to target value. The actual current output is less than preset value due to insufficient headroom voltage for power transistor. As a result, the voltage across the sense resistor fails to reach the regulation target. The headroom voltage is the summation of $V_{(\text{DROPOUT})}$ and $V_{(\text{CS_REG})}$.

If the TPS92623-Q1 is designed to operate in low-dropout condition, the open-circuit diagnostics must be disabled by pulling the DIAGEN pin voltage lower than $V_{\text{IL}(\text{DIAGEN})}$. Otherwise, the TPS92623-Q1 detects an open-circuit fault and reports a fault on the $\overline{\text{FAULT}}$ pin. The DIAGEN pin is used to avoid false diagnostics due to low supply voltage.

7.3.8 FAULT Bus Output with One-Fails-All-Fail

During normal operation, The $\overline{\text{FAULT}}$ pin of TPS92623-Q1 is weakly pulled up by an internal pullup current source, $I_{(\text{FAULT_pullup})}$. If any fault scenario occurs, the $\overline{\text{FAULT}}$ pin is strongly pulled low by the internal pulldown current sink, $I_{(\text{FAULT_pulldown})}$ to report out the fault alarm.

Meanwhile, the TPS92623-Q1 also monitors the $\overline{\text{FAULT}}$ pin voltage internally. If the $\overline{\text{FAULT}}$ pin of the TPS92623-Q1 is pulled low by external current sink below $V_{\text{IL}(\text{FAULT})}$, the current output is turned off even though there is no fault detected on owned outputs. The device does not resume to normal operation until the $\overline{\text{FAULT}}$ pin voltage rises above $V_{\text{IH}(\text{FAULT})}$.

Based on this feature, the TPS92623-Q1 device is able to construct a FAULT bus by tying $\overline{\text{FAULT}}$ pins from multiple TPS92623-Q1 devices to achieve one-fails-all-fail function as Figure 7-6 showing. The lower side TPS92623-Q1 (B) detects any kind of LED fault and pulls low the $\overline{\text{FAULT}}$ pin. The low voltage on $\overline{\text{FAULT}}$ pin

is detected by upper side TPS92623-Q1 (A) because the $\overline{\text{FAULT}}$ pins are connected of two devices. The upper side TPS92623-Q1 (A) turns off all output current for each channel as a result. If the $\overline{\text{FAULT}}$ pins of each TPS92623-Q1 are all connected to drive the base of an external PNP transistor as illustrated in Figure 7-7, the one-fails-all-fail function is disabled and only the faulty channel device is turned off.

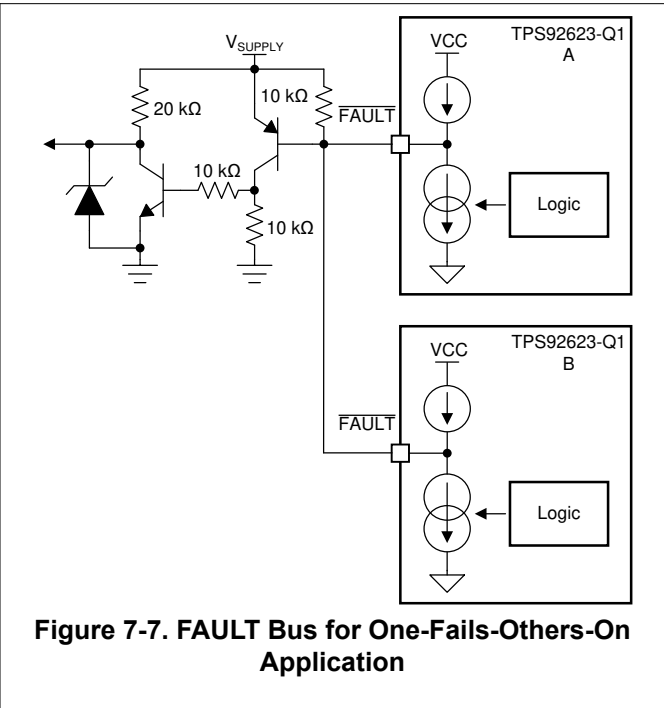
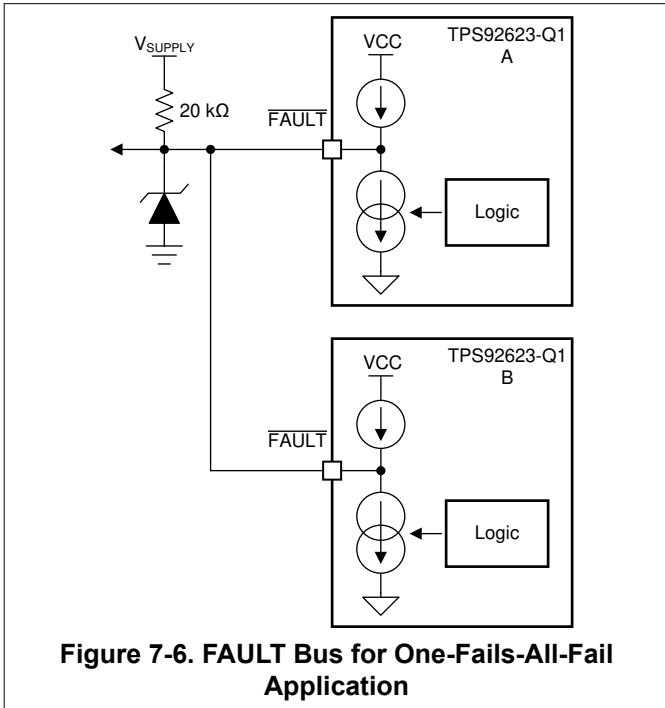

7.3.9 FAULT Table

Table 7-1. Fault Table With DIAGEN = HIGH (Full Function)

FAULT BUS STATUS	FAULT TYPE	DETECTION MECHANISM	CONTROL INPUT	DEGLITCH TIME	FAULT BUS	FAULT HANDLING ROUTINE	FAULT RECOVERY
$\overline{\text{FAULT}} = \text{H}$	Open-circuit or short-to-supply	$V_{(\text{IN})} - V_{(\text{OUT})} < V_{(\text{OPEN_th_rising})}$	PWMx = H	$t_{(\text{OPEN_deg})}$	Constant-current pulldown	Device turns failed output off and retries with constant current $I_{(\text{retry})}$, ignoring the PWM input.	Auto recovery
	Short-to-ground	$V_{(\text{OUT})} < V_{(\text{SG_th_falling})}$ OR $V_{(\text{RES})} < V_{(\text{SG_th_falling})}$	PWMx = H	$t_{(\text{SG_deg})}$	Constant-current pulldown	Device turns failed output off and retries with constant current $I_{(\text{retry})}$, ignoring the PWM input.	Auto recovery
	Overtemperature	$T_J > T_{(\text{TSD})}$		$t_{(\text{TSD_deg})}$	Constant-current pulldown	Device turns all output channels off.	Auto recovery
$\overline{\text{FAULT}} = \text{L}$	Fault is detected	Device turns all remained channels off and keeps retry on the failed channels. After the $\overline{\text{Fault}}$ pin is released, all channels are turned on after $t_{(\text{FAULT_recovery})}$ time.					
	No fault is detected	Device turns all output channels off.					

Table 7-2. Fault Table With DIAGEN = LOW (Full Function)

FAULT BUS STATUS	FAULT TYPE	DETECTION MECHANISM	CURRENT OUTPUT	DEGLITCH TIME	FAULT BUS	FAULT HANDLING ROUTINE	FAULT RECOVERY
$\overline{\text{FAULT}} = \text{H}$	Open-circuit or short-to-supply	Ignored					
	Short-to-ground	$V_{(\text{OUT})} < V_{(\text{SG_th_falling})}$ OR $V_{(\text{OUT})} < V_{(\text{SG_th_falling})}$	PWMx = H	$t_{(\text{SG_deg})}$	Constant-current pulldown	Device turns output off and retries with constant current $I_{(\text{retry})}$, ignoring the PWM input.	Auto recovery
	Overtemperature	$T_J > T_{(\text{TSD})}$		$t_{(\text{TSD_deg})}$	Constant-current pulldown	Device turns all output channels off.	Auto recovery
$\overline{\text{FAULT}} = \text{L}$	Fault is detected	Device turns all remained channels off and keeps retry on the failed channels. After the $\overline{\text{Fault}}$ pin is released, all channels are turned on after $t_{(\text{FAULT_recovery})}$ time.					
	No fault is detected	Device turns all output channels off.					

7.3.10 LED Fault Summary

Table 7-3. LED Connection Fault Summary

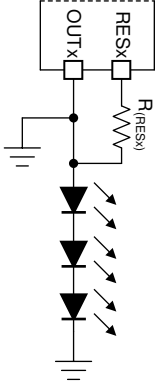
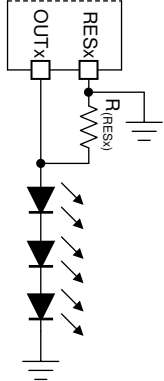
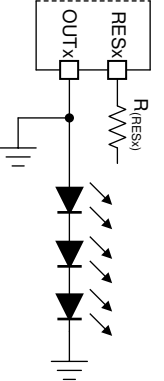
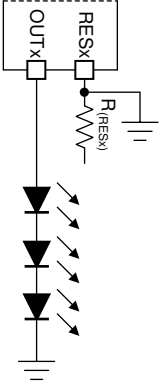
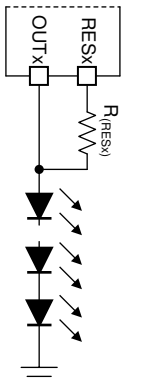
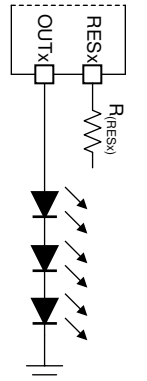
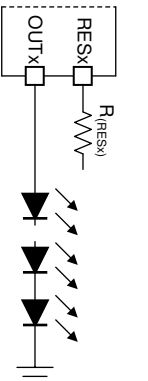
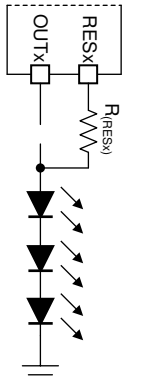
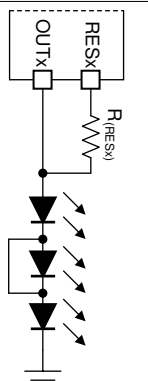
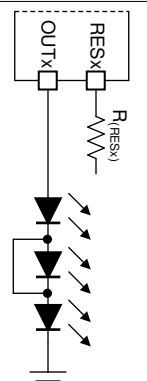
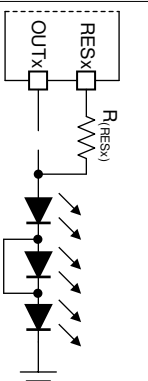
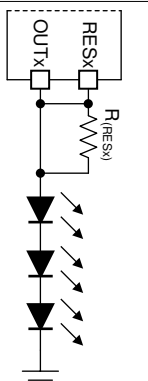
<p>Case 1</p> 	<p>Case 2</p> 	<p>Case 3</p> 	<p>Case 4</p> 
LED Short-to-GND Fault	LED Short-to-GND Fault	LED Short-to-GND Fault	LED Short-to-GND Fault
<p>Case 5</p> 	<p>Case 6</p> 	<p>Case 7</p> 	<p>Case 8</p> 
LED Open Fault	No Fault	LED Open Fault	LED Open Fault
<p>Case 9</p> 	<p>Case 10</p> 	<p>Case 11</p> 	<p>Case 12</p> 
No Fault	No Fault	LED Open Fault	No Fault

7.3.11 IO Pins Inner Connection

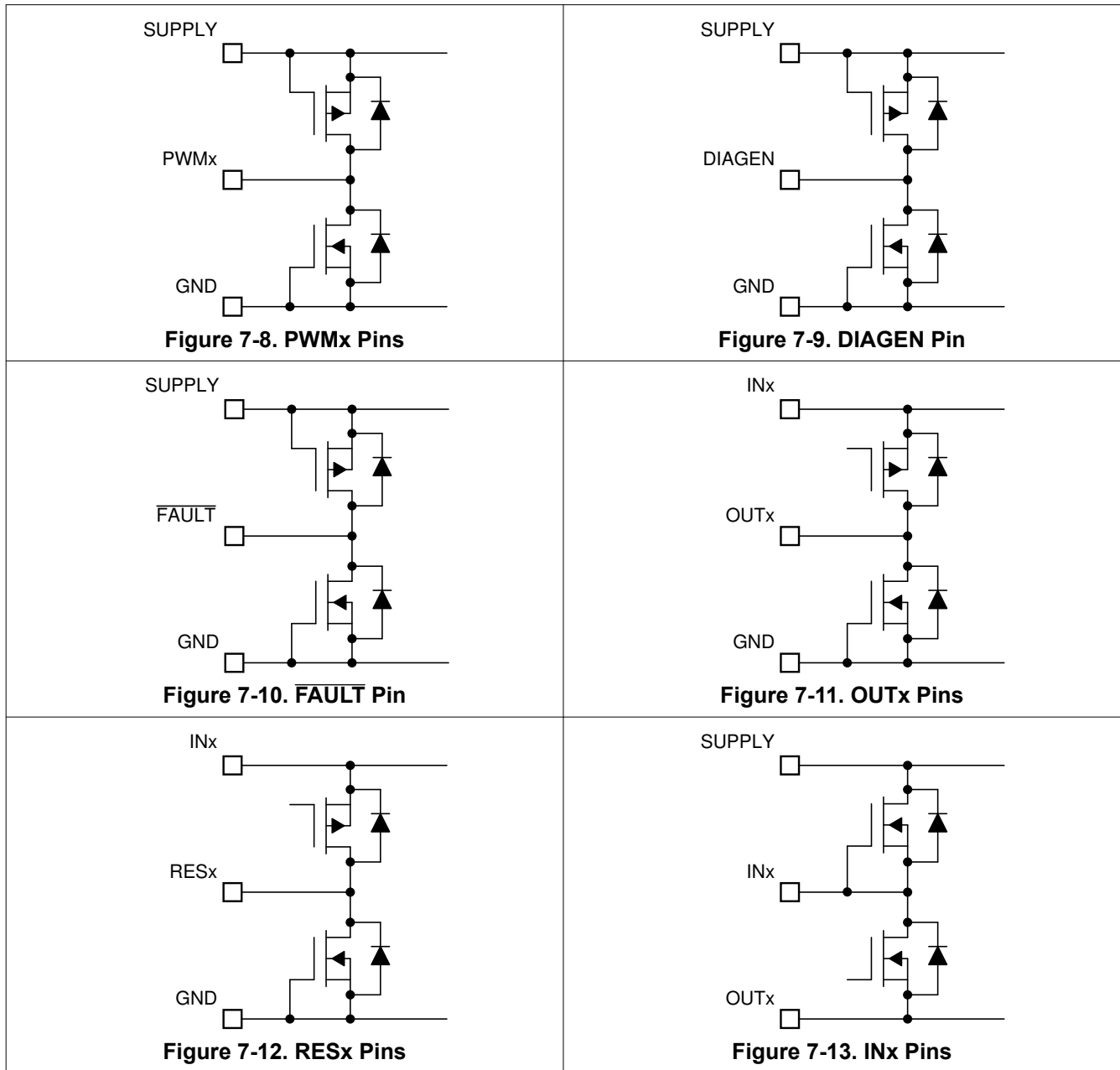

7.4 Device Functional Modes

7.4.1 Undervoltage Lockout, $V_{(SUPPLY)} < V_{(POR_rising)}$

When the device is in undervoltage lockout status, the TPS92623-Q1 device disables all functions until the supply rises above the $V_{(POR_rising)}$ threshold.

7.4.2 Normal Operation $V_{(SUPPLY)} \geq 4.5\text{ V}$

The device drives an LED string in normal operation. With enough voltage drop across SUPPLY and OUT, the device is able to drive the output in constant-current mode.

7.4.3 Low-Voltage Dropout Operation

When the device drives an LED string in low-dropout operation, if the $V_{(DROPOUT)}$ is less than the open-circuit detection threshold, the device can report a false open-circuit fault. TI recommends only enabling the open-circuit detection when the voltage across the IN and OUTx is higher than the maximum voltage of LED open rising threshold to avoid a false open-circuit detection.

7.4.4 Fault Mode

When the TPS92623-Q1 detects a fault, the device tries to pull down the $\overline{\text{FAULT}}$ pin with a constant current. If the FAULT bus is pulled down, the device switches to fault mode and consumes a fault current of $I_{(FAULT)}$.

8 Application and Implementation

Note

Information in the following applications sections is not part of the TI component specification, and TI does not warrant its accuracy or completeness. TI's customers are responsible for determining suitability of components for their purposes, as well as validating and testing their design implementation to confirm system functionality.

8.1 Application Information

In automotive lighting applications, thermal performance and LED diagnostics are always design challenges for linear LED drivers.

The TPS92623-Q1 device is capable of detecting LED open-circuit and LED short-circuits. To increase current driving capability, the TPS92623-Q1 device supports using an external shunt resistor to help dissipate heat as the following section, [Thermal Sharing Resistor \(OUTx and RESx\)](#), describes. This method provides a low-cost solution of using external resistors to minimize thermal accumulation on the device itself due to large voltage difference between input voltage and LED string forward voltage, while still keeping high accuracy of the total current output.

8.2 Typical Applications

8.2.1 BCM Controlled Rear Lamp With One-Fails-All-Fail Setup

The multiple TPS92623-Q1 devices are capable of driving different functions for automotive rear lamp including stop, turn indicator, tail, fog, reverse and center-high-mounted-stop-lamp. The one-fails-all-fail single lamp mode can be easily achieved by FAULT bus by shorting the FAULT pins.

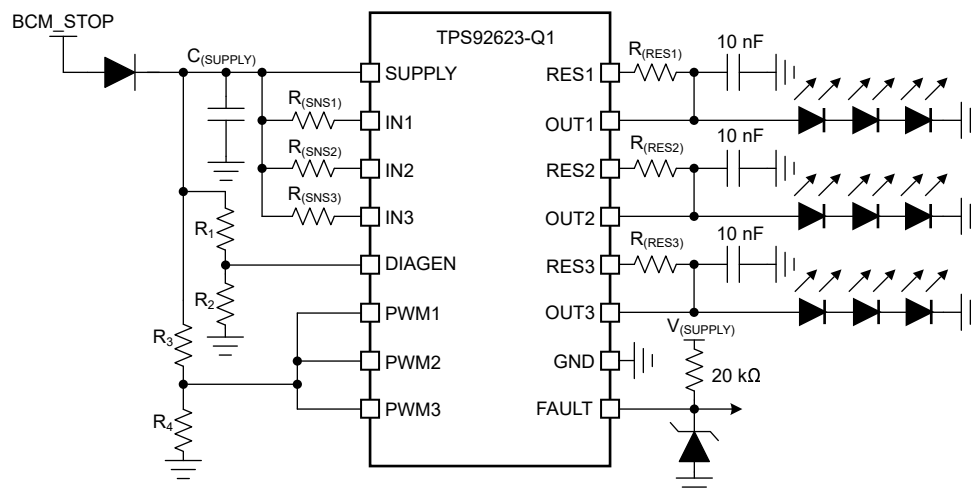

Figure 8-1. Typical Application Schematic

8.2.1.1 Design Requirements

Input voltage range is from 9 V to 16 V, and a total 9 strings with 3 LEDs in each string are required to achieve stop function. The LED maximum forward voltage, V_{F_MAX} is 2.5 V for each LED, while the minimum forward voltage, V_{F_MIN} is 1.9 V. The current requirement for each LED, $I_{(LED)}$ is 130 mA. The LED brightness and ON and OFF control is manipulated by body control module (BCM) directly by connecting and disconnecting the power supply to the LED load.

8.2.1.2 Detailed Design Procedure

Step 1: Determine the current sensing resistor, $R_{(SNSx)}$, by using [Equation 4](#).

$$R_{(SNSx)} = \frac{V_{(CS_REG)}}{I_{(OUTx_Tot)}} \quad (4)$$

where

- $V_{(CS_REG)} = 150 \text{ mV}$ (typical)
- $I_{(OUTx_Tot)} = 130 \text{ mA}$

According to design requirements, output current for each channel is same so that the $R_{(SNS1)} = R_{(SNS2)} = R_{(SNS3)} = 1.15 \Omega$. Two resistors in parallel can be used to achieve equivalent resistance when sense resistor is not a standard decade resistance value.

Step 2: Design the current distribution between $I_{(OUTx)}$ and $I_{(RESx)}$, and calculate the current sharing resistor, $R_{(RESx)}$, by using Equation 5. The $R_{(RESx)}$ value actually decides the current distribution for $I_{(OUTx)}$ path and $I_{(RESx)}$ path. TI recommends the current sharing resistor $R_{(RESx)}$ to consume 50% of the total current at typical supply operating voltage.

$$R_{(RESx)} = \frac{V_{(SUPPLY)} - V_{(OUTx)}}{I_{(OUTx_Tot)} \times 0.5} \quad (5)$$

where

- $V_{(SUPPLY)} = 12 \text{ V}$ (typical)
- $I_{(OUTx_Tot)} = 130 \text{ mA}$

The calculated result for $R_{(RESx)}$ resistor value including $R_{(RES1)}$, $R_{(RES2)}$ and $R_{(RES3)}$ is 85.4Ω when $V_{(OUTx)}$ is typical $3 \times 2.15 \text{ V} = 6.45 \text{ V}$.

Step 3: Design the threshold voltage of SUPPLY to enable the LED open-circuit diagnostics, and calculate voltage divider resistor value for **R1** and **R2** on DIAGEN pin.

The maximum forward voltage of LED-string is $3 \times 2.5 \text{ V} = 7.5 \text{ V}$. To avoid the open-circuit fault reported in low-dropout operation conditions, additional headroom between SUPPLY and OUTx must be considered. The TPS92623-Q1 device must disable open-circuit detection when the supply voltage is below LED-string maximum forward voltage plus $V_{(OPEN_th_rising)}$ and $V_{(CS_REG)}$. The voltage divider resistor, R1 and R2 value can be calculated by Equation 6.

$$R_1 = \left(\frac{V_{(OPEN_th_rising)} + V_{(CS_REG)} + V_{(OUTx)}}{V_{IL(DIAGEN)}} - 1 \right) \times R_2 \quad (6)$$

where

- $V_{(OPEN_th_rising)} = 420 \text{ mV}$ (maximum)
- $V_{(CS_REG)} = 156 \text{ mV}$
- $V_{IL(DIAGEN)} = 1.045 \text{ V}$ (minimum)
- $R_2 = 10 \text{ k}\Omega$ (recommended)

The calculated result for R1 is $67.3 \text{ k}\Omega$ when $V_{(OUTx)}$ maximum voltage is 7.5 V and $V_{(CS_REG)}$ is 156 mV .

Step 4: Design the threshold voltage of SUPPLY to turn on and off each channel of LED, and calculate voltage divider resistor value for **R3** and **R4** on PWM input pin.

The minimum forward voltage of LED string is $3 \times 1.9 \text{ V} = 5.7 \text{ V}$. To make sure the current output on each of LED-string is normal, each LED-string must be turned off when SUPPLY voltage is lower than LED minimum required forward voltage plus dropout voltage between INx to OUTx and $V_{(CS_REG)}$. The voltage divider resistor, R3 and R4 value can be calculated by Equation 7.

$$R_3 = \left(\frac{V_{(DROPOUT)} + V_{(CS_REG)} + V_{(OUTx)}}{V_{IH(PWM)}} - 1 \right) \times R_4 \tag{7}$$

where

- $V_{(DROPOUT)} = 300 \text{ mV}$ (typical)
- $V_{(CS_REG)} = 156 \text{ mV}$ (maximum)
- $V_{IH(PWM)} = 1.26 \text{ V}$ (maximum)
- $R_4 = 10 \text{ k}\Omega$ (recommended)

The calculated result for R3 is 38.9 kΩ when $V_{(OUTx)}$ minimum voltage is 5.7 V and $V_{(CS_REG)}$ is 156 mV.

8.2.1.3 Application Curves

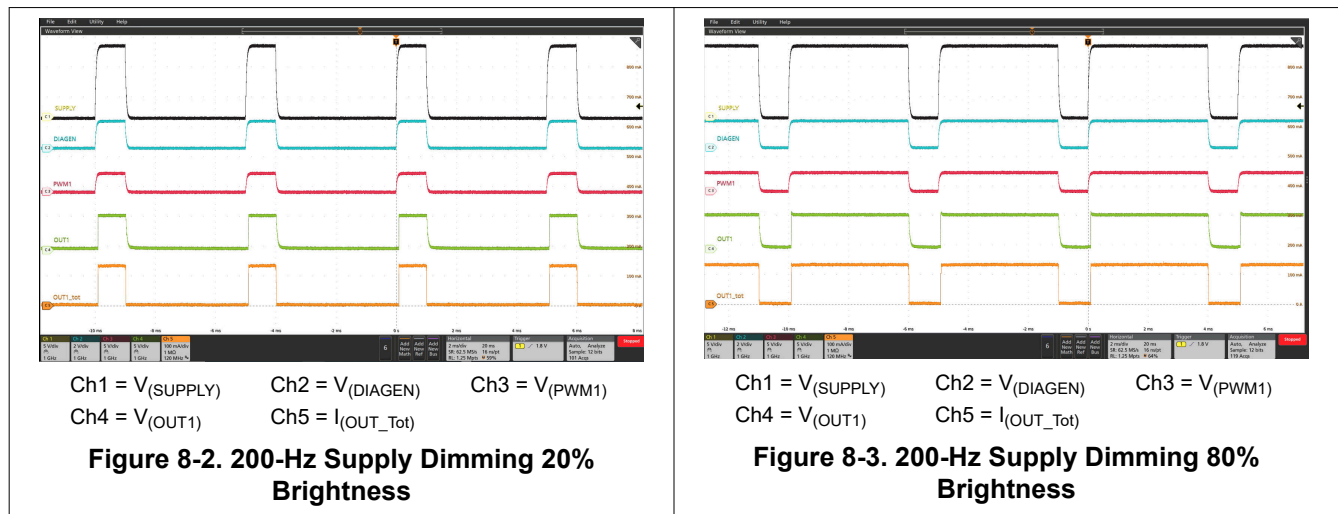

8.2.2 Independent PWM Controlled Rear Lamp By MCU

The TPS92623-Q1 device is able to drive the each current output channel independently by PWM input at PWM1, PWM2 and PWM3 pins. The PWM input signals comes from MCU to achieve sequential turn indicator feature.

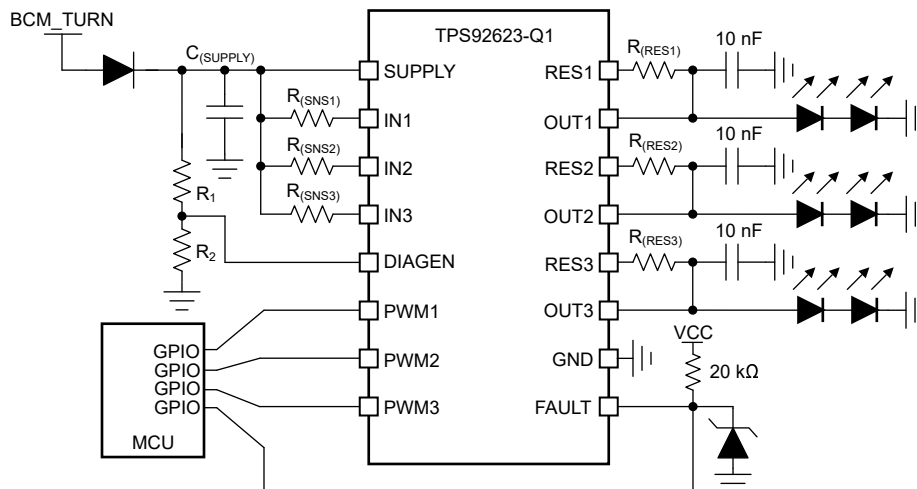

Figure 8-4. Typical Application Schematic

8.2.2.1 Design Requirements

Input voltage range is from 9 V to 16 V, and a total 6 strings with 2 LEDs in each string are required to achieve turn indicator function. The LED maximum forward voltage, V_{F_MAX} is 2.5 V for each LED, however the minimum forward voltage, V_{F_MIN} is 1.9 V. Each LED current is 130 mA and each output channel is independent controlled by MCU through individual GPIO.

8.2.2.2 Detailed Design Procedure

Step 1: Determine the current sensing resistor, $R_{(SNSx)}$ by using [Equation 8](#).

$$R_{(SNSx)} = \frac{V_{(CS_REG)}}{I_{(OUTx_Tot)}} \quad (8)$$

where

- $V_{(CS_REG)} = 150$ mV (typical)
- $I_{(OUTx_Tot)} = 130$ mA

According to design requirements, output current for each channel is same so that the calculated $R_{(SNS1)} = R_{(SNS2)} = R_{(SNS3)} = 1.15 \Omega$.

Step 2: Design the current distribution between $I_{(OUTx)}$ and $I_{(RESx)}$, and calculate the current sharing resistor, $R_{(RESx)}$, by using [Equation 9](#). The $R_{(RESx)}$ value actually decides the current distribution for $I_{(OUTx)}$ path and $I_{(RESx)}$ path, basic principle is to design the $R_{(RESx)}$ to consume appropriate 50% total power dissipation at typical supply operating voltage.

$$R_{(RESx)} = \frac{V_{(SUPPLY)} - V_{(OUTx)}}{I_{(OUTx_Tot)} \times 0.5} \quad (9)$$

where

- $V_{(SUPPLY)} = 12$ V (typical)
- $I_{(OUTx_Tot)} = 130$ mA (maximum)

The calculated result for $R_{(RESx)}$ resistor value including $R_{(RES1)}$, $R_{(RES2)}$ and $R_{(RES3)}$ is 117Ω when $V_{(OUTx)}$ is typical 2×2.2 V = 4.4 V.

Step 3: Design the threshold voltage of SUPPLY to enable the LED open-circuit, and calculate voltage divider resistor value for **R1** and **R2** on DIAGEN pin.

The maximum forward voltage of LED-string is 2×2.5 V = 5 V. To avoid the open-circuit fault reported in low-dropout operation conditions, additional headroom between SUPPLY and OUTx must be considered. The TPS92623-Q1 device must disable open-circuit detection when the supply voltage is below LED-string maximum forward voltage plus $V_{(OPEN_th_rising)}$ and $V_{(CS_REG)}$. The voltage divider resistor, R1 and R2 value can be calculated by [Equation 10](#).

$$R_1 = \left(\frac{V_{(OPEN_th_rising)} + V_{(CS_REG)} + V_{(OUTx)}}{V_{IL(DIAGEN)}} - 1 \right) \times R_2 \quad (10)$$

where

- $V_{(OPEN_th_rising)} = 420$ mV (maximum)
- $V_{(CS_REG)} = 156$ mV (maximum)
- $V_{IL(DIAGEN)} = 1.045$ V (minimum)
- $R_2 = 10$ k Ω (recommended)

TPS92623-Q1

SLVSFS4A – DECEMBER 2021 – REVISED JUNE 2022

The calculated result for R1 is 43.4 kΩ when $V_{(OUTX)}$ maximum voltage is 5 V and $V_{(CS_REG)}$ is 156 mV.

8.2.2.3 Application Curves

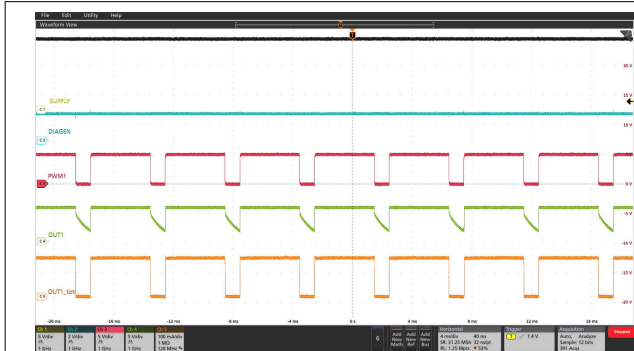

Ch1 = $V_{(SUPPLY)}$ Ch2 = $V_{(DIAGEN)}$ Ch3 = $V_{(PWM1)}$
Ch4 = $V_{(OUT1)}$ Ch5 = $I_{(OUT_Tot)}$

Figure 8-5. 200-Hz PWM Dimming at 80% Duty Cycle

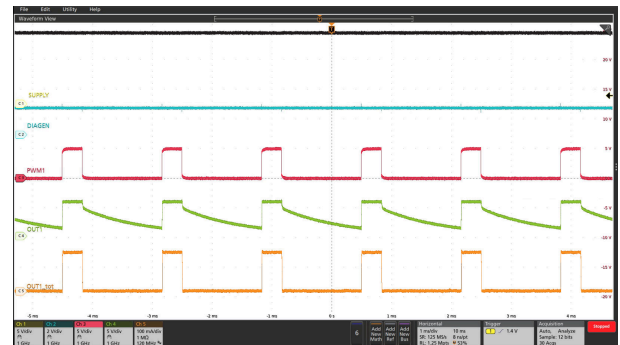

Ch1 = $V_{(SUPPLY)}$ Ch2 = $V_{(DIAGEN)}$ Ch3 = $V_{(PWM1)}$
Ch4 = $V_{(OUT1)}$ Ch5 = $I_{(OUT_Tot)}$

Figure 8-6. 600-Hz PWM Dimming at 20% Duty Cycle

9 Power Supply Recommendations

The TPS92623-Q1 is designed to operate from an automobile electrical power system within the range specified in [Power Supply](#). The V_{SUPPLY} input must be protected from reverse voltage and voltage dump condition over 40 V. The impedance of the input supply rail must be low enough that the input current transient does not cause drop below LED string required forward voltage. If the input supply is connected with long wires, additional bulk capacitance can be required in addition to normal input capacitor.

10 Layout

10.1 Layout Guidelines

Thermal dissipation is the primary consideration for TPS92623-Q1 layout.

- TI recommends large thermal dissipation area in both top and bottom layers of PCB. The copper pouring area in same layer with TPS92623-Q1 footprint must directly cover the thermal pad land of the device with wide connection as much as possible. The copper pouring in opposite PCB layer or inner layers must be connected to thermal pad directly through multiple thermal vias.
- TI recommends to place $R_{(RESx)}$ resistors away from the TPS92623-Q1 device with more than 20-mm distance, because $R_{(RESx)}$ resistors are dissipating some amount of the power as well as the TPS92623-Q1. Place two heat source components apart to reduce the thermal accumulation concentrated at small PCB area. The large copper pouring area is also required surrounding the $R_{(RESx)}$ resistors for helping thermal dissipating.

The noise immunity is the secondary consideration for TPS92623-Q1 layout.

- TI recommends to place the noise decoupling capacitors for SUPPLY pin as close as possible to the pins.
- TI recommends to place the $R_{(SNSx)}$ resistor as close as possible to the INx pins with the shortest PCB track to SUPPLY pin.

10.2 Layout Example

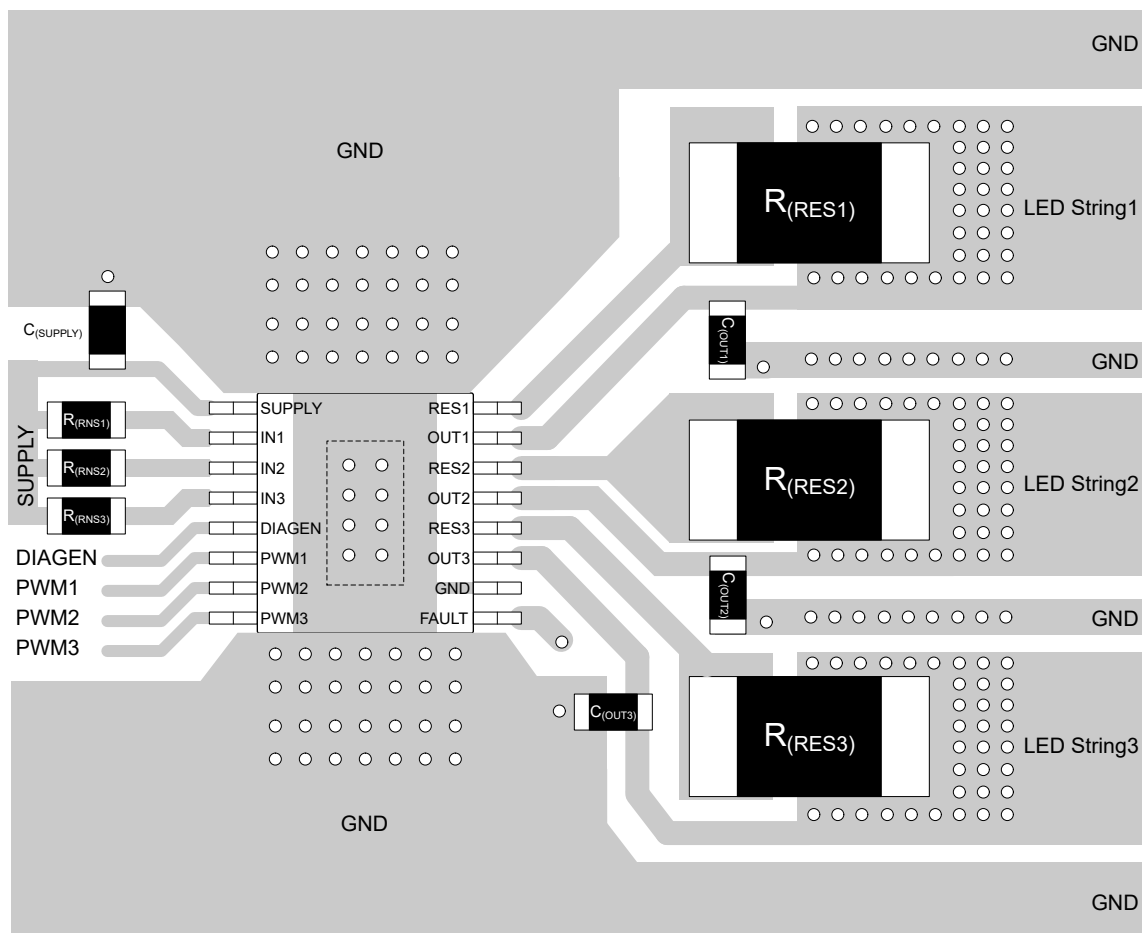

Figure 10-1. TPS92623-Q1 Example Layout Diagram

11 Device and Documentation Support

11.1 Receiving Notification of Documentation Updates

To receive notification of documentation updates, navigate to the device product folder on ti.com. Click on *Subscribe to updates* to register and receive a weekly digest of any product information that has changed. For change details, review the revision history included in any revised document.

11.2 Support Resources

TI E2E™ [support forums](#) are an engineer's go-to source for fast, verified answers and design help — straight from the experts. Search existing answers or ask your own question to get the quick design help you need.

Linked content is provided "AS IS" by the respective contributors. They do not constitute TI specifications and do not necessarily reflect TI's views; see TI's [Terms of Use](#).

11.3 Trademarks

PowerPAD™ and TI E2E™ are trademarks of Texas Instruments.
All trademarks are the property of their respective owners.

11.4 Electrostatic Discharge Caution



This integrated circuit can be damaged by ESD. Texas Instruments recommends that all integrated circuits be handled with appropriate precautions. Failure to observe proper handling and installation procedures can cause damage.

ESD damage can range from subtle performance degradation to complete device failure. Precision integrated circuits may be more susceptible to damage because very small parametric changes could cause the device not to meet its published specifications.

11.5 Glossary

[TI Glossary](#) This glossary lists and explains terms, acronyms, and definitions.

12 Mechanical, Packaging, and Orderable Information

The following pages include mechanical, packaging, and orderable information. This information is the most current data available for the designated devices. This data is subject to change without notice and revision of this document. For browser-based versions of this data sheet, refer to the left-hand navigation.

PACKAGING INFORMATION

Orderable Device	Status (1)	Package Type	Package Drawing	Pins	Package Qty	Eco Plan (2)	Lead finish/ Ball material (6)	MSL Peak Temp (3)	Op Temp (°C)	Device Marking (4/5)	Samples
TPS92623QPWRQ1	ACTIVE	HTSSOP	PWP	16	2000	RoHS & Green	NIPDAU	Level-3-260C-168 HR	-40 to 125	92623Q	Samples

(1) The marketing status values are defined as follows:

ACTIVE: Product device recommended for new designs.

LIFEBUY: TI has announced that the device will be discontinued, and a lifetime-buy period is in effect.

NRND: Not recommended for new designs. Device is in production to support existing customers, but TI does not recommend using this part in a new design.

PREVIEW: Device has been announced but is not in production. Samples may or may not be available.

OBSELETE: TI has discontinued the production of the device.

(2) **RoHS:** TI defines "RoHS" to mean semiconductor products that are compliant with the current EU RoHS requirements for all 10 RoHS substances, including the requirement that RoHS substance do not exceed 0.1% by weight in homogeneous materials. Where designed to be soldered at high temperatures, "RoHS" products are suitable for use in specified lead-free processes. TI may reference these types of products as "Pb-Free".

RoHS Exempt: TI defines "RoHS Exempt" to mean products that contain lead but are compliant with EU RoHS pursuant to a specific EU RoHS exemption.

Green: TI defines "Green" to mean the content of Chlorine (Cl) and Bromine (Br) based flame retardants meet JS709B low halogen requirements of <=1000ppm threshold. Antimony trioxide based flame retardants must also meet the <=1000ppm threshold requirement.

(3) MSL, Peak Temp. - The Moisture Sensitivity Level rating according to the JEDEC industry standard classifications, and peak solder temperature.

(4) There may be additional marking, which relates to the logo, the lot trace code information, or the environmental category on the device.

(5) Multiple Device Markings will be inside parentheses. Only one Device Marking contained in parentheses and separated by a "-" will appear on a device. If a line is indented then it is a continuation of the previous line and the two combined represent the entire Device Marking for that device.

(6) Lead finish/Ball material - Orderable Devices may have multiple material finish options. Finish options are separated by a vertical ruled line. Lead finish/Ball material values may wrap to two lines if the finish value exceeds the maximum column width.

Important Information and Disclaimer:The information provided on this page represents TI's knowledge and belief as of the date that it is provided. TI bases its knowledge and belief on information provided by third parties, and makes no representation or warranty as to the accuracy of such information. Efforts are underway to better integrate information from third parties. TI has taken and continues to take reasonable steps to provide representative and accurate information but may not have conducted destructive testing or chemical analysis on incoming materials and chemicals. TI and TI suppliers consider certain information to be proprietary, and thus CAS numbers and other limited information may not be available for release.

In no event shall TI's liability arising out of such information exceed the total purchase price of the TI part(s) at issue in this document sold by TI to Customer on an annual basis.

TAPE AND REEL INFORMATION

QUADRANT ASSIGNMENTS FOR PIN 1 ORIENTATION IN TAPE



*All dimensions are nominal

Device	Package Type	Package Drawing	Pins	SPQ	Reel Diameter (mm)	Reel Width W1 (mm)	A0 (mm)	B0 (mm)	K0 (mm)	P1 (mm)	W (mm)	Pin1 Quadrant
TPS92623QPWPRQ1	HTSSOP	PWP	16	2000	330.0	12.4	6.9	5.6	1.6	8.0	12.0	Q1

TAPE AND REEL BOX DIMENSIONS

*All dimensions are nominal

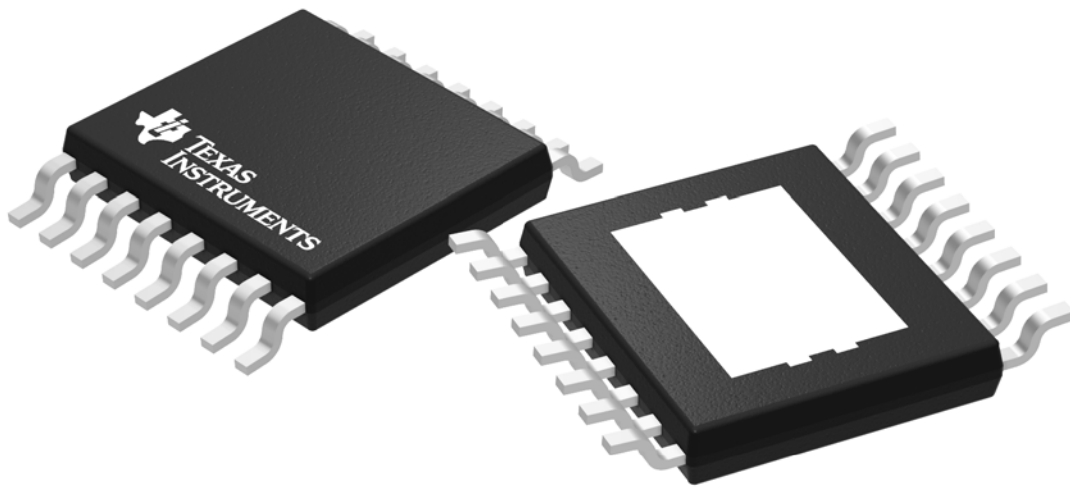
Device	Package Type	Package Drawing	Pins	SPQ	Length (mm)	Width (mm)	Height (mm)
TPS92623QPWPRQ1	HTSSOP	PWP	16	2000	356.0	356.0	35.0



Images above are just a representation of the package family, actual package may vary.
Refer to the product data sheet for package details.

IMPORTANT NOTICE AND DISCLAIMER

TI PROVIDES TECHNICAL AND RELIABILITY DATA (INCLUDING DATA SHEETS), DESIGN RESOURCES (INCLUDING REFERENCE DESIGNS), APPLICATION OR OTHER DESIGN ADVICE, WEB TOOLS, SAFETY INFORMATION, AND OTHER RESOURCES "AS IS" AND WITH ALL FAULTS, AND DISCLAIMS ALL WARRANTIES, EXPRESS AND IMPLIED, INCLUDING WITHOUT LIMITATION ANY IMPLIED WARRANTIES OF MERCHANTABILITY, FITNESS FOR A PARTICULAR PURPOSE OR NON-INFRINGEMENT OF THIRD PARTY INTELLECTUAL PROPERTY RIGHTS.

These resources are intended for skilled developers designing with TI products. You are solely responsible for (1) selecting the appropriate TI products for your application, (2) designing, validating and testing your application, and (3) ensuring your application meets applicable standards, and any other safety, security, regulatory or other requirements.

These resources are subject to change without notice. TI grants you permission to use these resources only for development of an application that uses the TI products described in the resource. Other reproduction and display of these resources is prohibited. No license is granted to any other TI intellectual property right or to any third party intellectual property right. TI disclaims responsibility for, and you will fully indemnify TI and its representatives against, any claims, damages, costs, losses, and liabilities arising out of your use of these resources.

TI's products are provided subject to [TI's Terms of Sale](#) or other applicable terms available either on [ti.com](https://www.ti.com) or provided in conjunction with such TI products. TI's provision of these resources does not expand or otherwise alter TI's applicable warranties or warranty disclaimers for TI products.

TI objects to and rejects any additional or different terms you may have proposed.

Mailing Address: Texas Instruments, Post Office Box 655303, Dallas, Texas 75265
Copyright © 2024, Texas Instruments Incorporated

Looking for pricing, stock, or lifecycle information?

Click below to explore more details on WIN SOURCE:

 [View TPS92623QPWPRQ1](#) on WIN SOURCE

 [Texas Instruments](#) Information

Optimize Your Supply Chain with WIN SOURCE Solutions

-  Global Sourcing Solution
-  Obsolete Management
-  Cost Control Management
-  Shortage Management
-  Alternative Solution
-  Excess Inventory Management