



# THE DATASHEET OF TPA2001D2EVM



**TPA2001D2**  
**Filterless Class-D**  
**Audio Power Amplifier**  
**Evaluation Module**

*User's Guide*

## **IMPORTANT NOTICE**

Texas Instruments and its subsidiaries (TI) reserve the right to make changes to their products or to discontinue any product or service without notice, and advise customers to obtain the latest version of relevant information to verify, before placing orders, that information being relied on is current and complete. All products are sold subject to the terms and conditions of sale supplied at the time of order acknowledgment, including those pertaining to warranty, patent infringement, and limitation of liability.

TI warrants performance of its semiconductor products to the specifications applicable at the time of sale in accordance with TI's standard warranty. Testing and other quality control techniques are utilized to the extent TI deems necessary to support this warranty. Specific testing of all parameters of each device is not necessarily performed, except those mandated by government requirements.

Customers are responsible for their applications using TI components.

In order to minimize risks associated with the customer's applications, adequate design and operating safeguards must be provided by the customer to minimize inherent or procedural hazards.

TI assumes no liability for applications assistance or customer product design. TI does not warrant or represent that any license, either express or implied, is granted under any patent right, copyright, mask work right, or other intellectual property right of TI covering or relating to any combination, machine, or process in which such semiconductor products or services might be or are used. TI's publication of information regarding any third party's products or services does not constitute TI's approval, warranty or endorsement thereof.

# Read This First

---

---

---

---

### ***Related Documentation From Texas Instruments***

- ***TI Plug-N-Play Audio Amplifier Evaluation Platform*** (literature number SLOU011) provides detailed information on the evaluation platform and its use with TI audio evaluation modules.
- ***TPA2001D2 1-W STEREO CLASS-D AUDIO POWER AMPLIFIER*** (literature number SLOS292) This is the data sheet for the TPA2001D2 audio amplifier integrated circuit.

### ***FCC Warning***

This equipment is intended for use in a laboratory test environment only. It generates, uses, and can radiate radio frequency energy and has not been tested for compliance with the limits of computing devices pursuant to subpart J of part 15 of FCC rules, which are designed to provide reasonable protection against radio frequency interference. Operation of this equipment in other environments may cause interference with radio communications, in which case the user at his own expense will be required to take whatever measures may be required to correct this interference.



# Contents

---

---

---

<b>1</b>	<b>Introduction</b>	<b>1-1</b>
1.1	Feature Highlights	1-2
1.2	Description	1-3
1.3	TPA2001D2 EVM Specifications	1-4
<b>2</b>	<b>Operation</b>	<b>2-1</b>
2.1	Precautions	2-2
2.2	Quick Start List for Platform	2-3
2.3	Quick Start List for Stand-Alone	2-5
2.4	Reference	2-6
2.4.1	TPA2001D2 EVM Connected for Stereo Output	2-6
2.4.2	TPA2001D2 Audio Power Amplifier Evaluation Module Parts List	2-7
2.4.3	TPA2001D2 Filterless Class-D EVM Schematic	2-8
2.4.4	TPA2001D2 Filterless Class-D EVM PCB Layers	2-9

# Figures

---

---

---

1-1	The TI TPA2001D2 Audio Amplifier EVM Without Output Filter—Top View . . . . .	1-3
1-2	The TI TPA2001D2 Audio Amplifier EVM Without Output Filter—Bottom View . . . . .	1-3
2-1	Quick Start Platform Map . . . . .	2-2
2-2	Module Preparation . . . . .	2-4
2-3	Quick Start Module Map . . . . .	2-5
2-4	TPA2001D2 EVM Connected for Stereo Output . . . . .	2-6
2-5	TPA2001D2 Filterless Class-D EVM Schematic Diagram . . . . .	2-8
2-6	TPA2001D2 Filterless Class-D EVM Top Assembly . . . . .	2-9
2-7	TPA2001D2 Filterless Class-D EVM Bottom Assembly . . . . .	2-9
2-8	TPA2001D2 Filterless Class-D EVM Top Layer . . . . .	2-10
2-9	TPA2001D2 Filterless Class-D EVM Bottom Layer . . . . .	2-10

# Tables

---

---

---

2-1	Typical TI Plug-N-Play Platform Jumper and Switch Settings for the TPA2001D2 . . . . .	2-1
2-2	Typical TPA2001D2 EVM Jumper Settings . . . . .	2-1
2-3	Platform Jumper and Switch Settings for the TPA2001D2 . . . . .	2-3
2-4	Typical TPA2001D2 EVM Jumper Settings . . . . .	2-4
2-5	TPA2001D2 EVM Gain Settings . . . . .	2-6
2-6	TPA2001D2 EVM Parts List . . . . .	2-7

# Introduction

---

---

---

---

This chapter provides an overview of the Texas Instruments (TI) TPA2001D2 filterless class-D audio amplifier evaluation module (SLOP315). It includes a list of EVM features, a brief description of the module illustrated with a pictorial diagram, and a list of EVM specifications.

<b>Topic</b>	<b>Page</b>
<b>1.1 Feature Highlights</b> .....	<b>1-2</b>
<b>1.2 Description</b> .....	<b>1-3</b>
<b>1.3 TPA2001D2 EVM Specifications</b> .....	<b>1-4</b>

## 1.1 Feature Highlights

The TI TPA2001D2 audio amplifier evaluation module and the TI plug-n-play audio amplifier evaluation platform include the following features:

- TPA2001D2 Stereo 1-W Filterless Class-D Audio Power Amplifier Evaluation Module
  - Class-D without output filter
  - Internal depop circuitry to minimize transients in outputs
  - High efficiency
  - Low distortion
  - Low supply current (8 mA)
  - 1 W per channel output power into 8  $\Omega$  at 5 V
  - Low current consumption in shutdown mode
  - Four selectable gain settings: 8, 12, 17.5, and 23.5 dB
  - Differential stereo inputs and outputs
  - 24-pin TSSOP PWP package
- Quick and Easy Configuration With the TI Plug-N-Play Audio Amplifier Evaluation Platform
  - Evaluation module is designed to simply plug into the platform, automatically making all signal, control, and power connections
  - Platform provides flexible power options
  - Jumpers on the platform select power and module control options
  - Switches on the platform route signals
  - Platform provides quick and easy audio input and output connections
- Platform Power Options
  - External 5-V – 15-V dc  $V_{CC}$  supply inputs
  - External regulated  $V_{DD}$  supply input
  - Socket for onboard 5 V/3.3 V  $V_{DD}$  voltage regulator EVM
  - Onboard overvoltage and reverse polarity power protection
- Platform Audio Input and Output Connections
  - Left and right RCA phono jack inputs
  - Miniature stereo phone jack input
  - Left and right RCA phono jack outputs
  - Left and right compression speaker terminal outputs
  - Miniature stereo headphone jack output

## 1.2 Description

The TPA2001D2 filterless class-D stereo audio power amplifier evaluation module is a complete, 1-W per channel class-D stereo audio power amplifier that can operate without an output filter. It consists of the TI TPA2001D2 class-D stereo 1-W audio power amplifier IC along with a small number of other parts mounted on a circuit board that measures approximately 2-1/4 inches by 1-1/2 inches (Figure 1–1 and Figure 1–2).

Figure 1–1. The TI TPA2001D2 Audio Amplifier EVM Without Output Filter—Top View

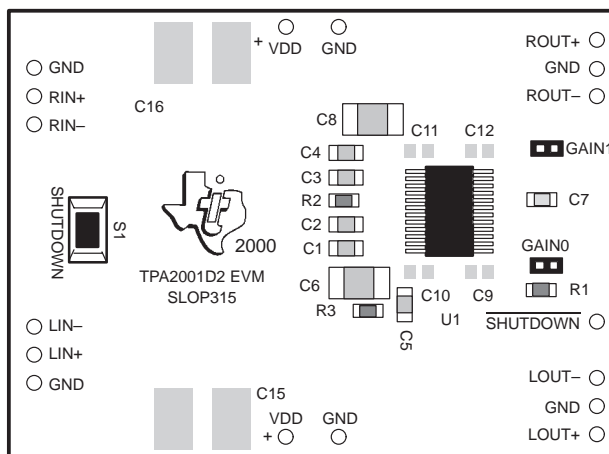
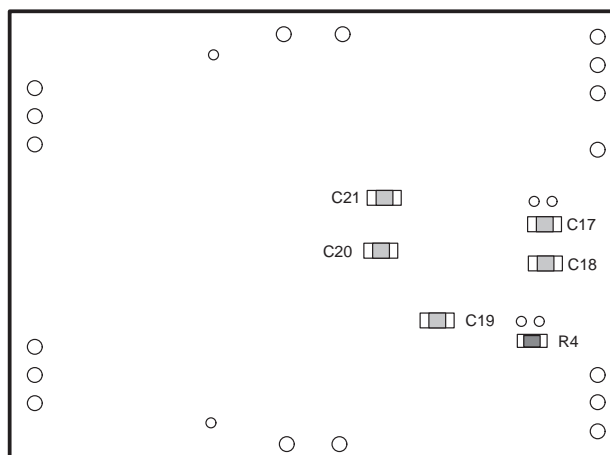

Figure 1–2. The TI TPA2001D2 Audio Amplifier EVM Without Output Filter—Bottom View



Single in-line header pins extend from the underside of the module circuit board to allow the EVM to be plugged into the TI plug-n-play audio amplifier evaluation platform, or to be wired directly into existing circuits and equipment when used stand-alone.

The platform has room for a single TPA2001D2 evaluation module and is a convenient vehicle for demonstrating TI's audio power amplifier and related evaluation modules. The EVMs simply plug into the platform, which automatically provides power to the modules, interconnects them correctly, and connects them to a versatile array of standard audio input and output jacks and connectors. Easy-to-use configuration controls allow the platform and EVMs to quickly model many possible end-equipment configurations.

There is nothing to build, nothing to solder, and nothing but the speakers included with the platform to *hook up*.

### 1.3 TPA2001D2 EVM Specifications

Supply voltage range, $V_{DD}$ .....	4.5 V to 5.5 V
Supply current, $I_{DD}$ .....	1 A max
Continuous output power per channel, $P_O$ : 8 $\Omega$ , $V_{DD} = 5$ V .....	1 W
Minimum load impedance, $R_L$ .....	8 $\Omega$

## Operation

The steps in this chapter can be followed to quickly prepare the TPA2001D2 filterless class-D audio amplifier EVM for use. Using the TPA2001D2 with the TI plug-n-play audio amplifier evaluation platform is a quick and easy way to connect power, signal and control inputs, and signal outputs to the EVM using standard connectors. However, the audio amplifier evaluation module can be used stand-alone by making connections directly to the module pins, and can be wired directly into existing circuits or equipment.

The platform switch and jumper settings shown in Table 2–1 are typical for the TPA2001D2 EVM and will cause the TPA2001D2 to shut down when a plug is inserted into platform headphone jack J10.

*Table 2–1. Typical TI Plug-N-Play Platform Jumper and Switch Settings for the TPA2001D2*

EVM	JP4	JP5	JP6	JP7	JP8	S2	S3
P-N-P Platform	X	ON	Mute	X	Lo	Note 2	U5

**Notes:** 1) ON = Jumper installed, OFF = Jumper **NOT** Installed, X = Don't care  
 2) Set S2 to ON when signal conditioning board is installed in U1; set S2 to OFF when no signal conditioning board is installed.

*Table 2–2. Typical TPA2001D2 EVM Jumper Settings*

EVM	GAIN0	GAIN1
TPA2001D2	OFF	OFF

**Note:** ON = Jumper installed, OFF = Jumper **NOT** Installed, X = Don't care

Topic	Page
2.1 Precautions .....	2–2
2.2 Quick Start List for Platform .....	2–3
2.3 Quick Start List for Stand-Alone .....	2–5
2.4 Reference .....	2–6

## 2.1 Precautions

**Power Supply Input Polarity and Maximum Voltage**  
 Always ensure that the polarity and voltage of the external power connected to  $V_{CC}$  power input connector J1, J2, and/or  $V_{DD}$  power input connector J6 are correct. Overvoltage or reverse-polarity power applied to these terminals can open onboard soldered-in fuses and cause other damage to the platform, installed evaluation modules, and/or the power source.

**Inserting or Removing EVM Boards**  
 Do not insert or remove EVM boards with power applied—damage to the EVM board, the platform, or both may result.

Figure 2–1. Quick Start Platform Map

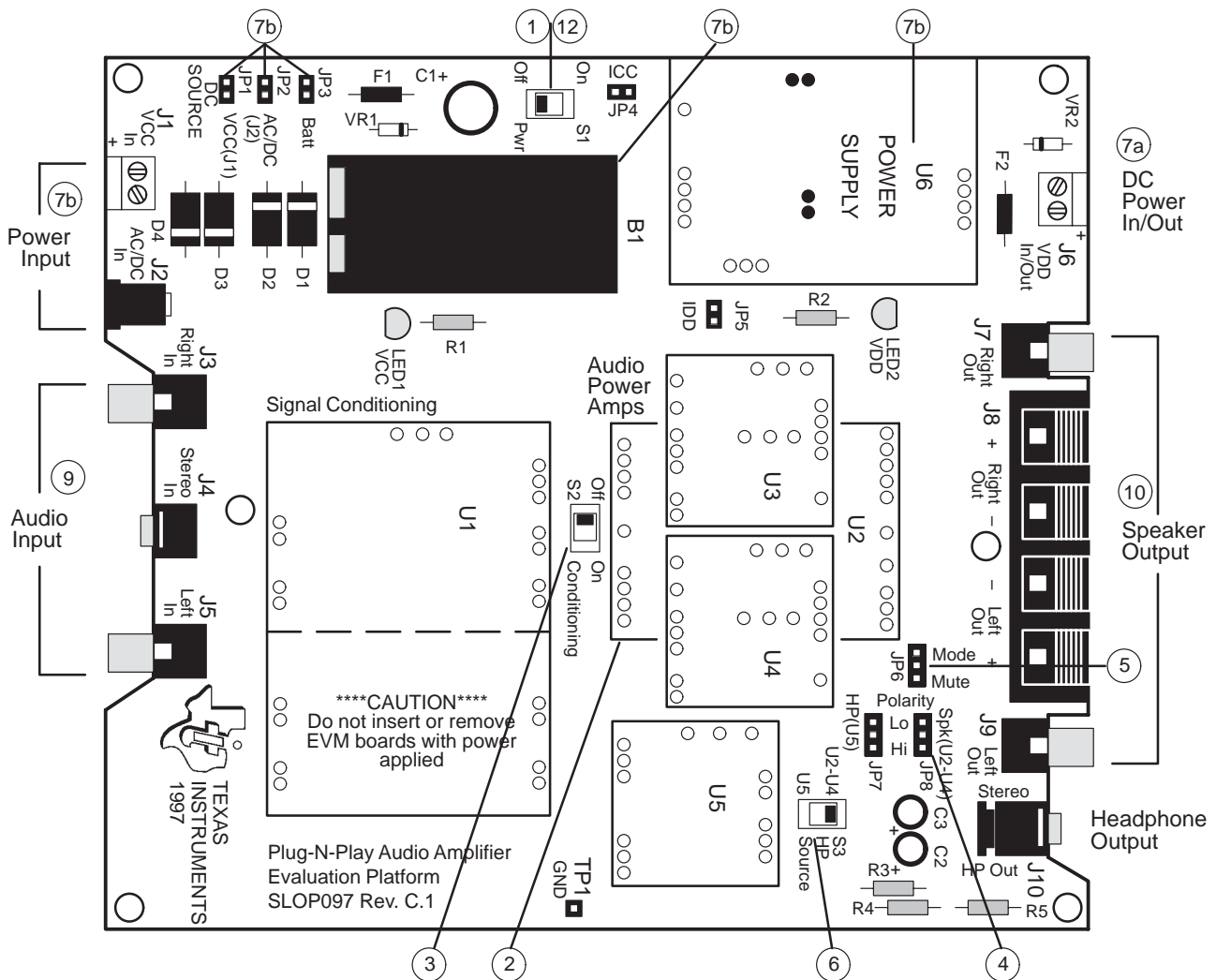

## 2.2 Quick Start List for Platform

Follow these steps when using the TPA2001D2 EVM with the TI plug-n-play audio amplifier evaluation platform (see the platform user's guide, literature number SLOU011, for additional details). Numbered callouts for selected steps are shown in Figure 2–1 and Figure 2–2.

### Platform preparations

- 1) Ensure that all external power sources are set to **OFF** and that the platform power switch **S1** is set to **OFF**.
- 2) Install a TPA2001D2 module in platform socket **U2**, taking care to align the module pins correctly.
- 3) Use switch **S2** to select or bypass the signal conditioning EVM (**U1**).
- 4) Set control signal **Polarity** jumper **JP8** to **Lo**.
- 5) Set jumper **JP6** to select the **Mute** control input (causes the TPA2001D2 to shut down if a plug is inserted into platform headphone jack **J10**).
- 6) If a headphone amplifier will be installed in **U5**, set headphone source switch **S3** to **U5**.

Table 2–3. Platform Jumper and Switch Settings for the TPA2001D2

EVM	JP4	JP5	JP6	JP7	JP8	S2	S3
P-N-P Platform	X	ON	Mute	X	Lo	Note 2	U5

**Notes:** 1) ON = Jumper installed, OFF = Jumper **NOT** Installed, X = Don't care  
 2) Set **S2** to **ON** when signal conditioning board is installed in **U1**; set **S2** to **OFF** when no signal conditioning board is installed.

### Power supply

- 7) Select and connect the power supply (ensure power supply is set to **OFF**):
  - a) Connect an external regulated power supply set to 5 V to platform  $V_{DD}$  power input connector **J6** taking care to observe marked polarity, or
  - b) Install a voltage regulator EVM (SLVP097 or equiv.) in platform socket **U6**. Connect a 7-V – 12-V power source to a platform  $V_{CC}$  power input **J1** or **J2** and jumper the appropriate power input (see platform user's guide). If using **J1**, **J2**, or **B1**, set **S1** to **ON** to supply power to the EVM.

### Inputs and outputs

- 8) Ensure that the audio signal source level is set to minimum.
- 9) Connect the audio source to left and right RCA phono jacks **J3** and **J5** or stereo miniature phone jack **J4**.
- 10) Connect speakers to left and right RCA jacks **J7** and **J9** or to stripped wire speaker connectors **J8**.

**Evaluation Module Preparations**

- 11) Use jumpers **GAIN0** and **GAIN1** to set the gain (Figure 2–2 and Table 2–4).

Figure 2–2. Module Preparation

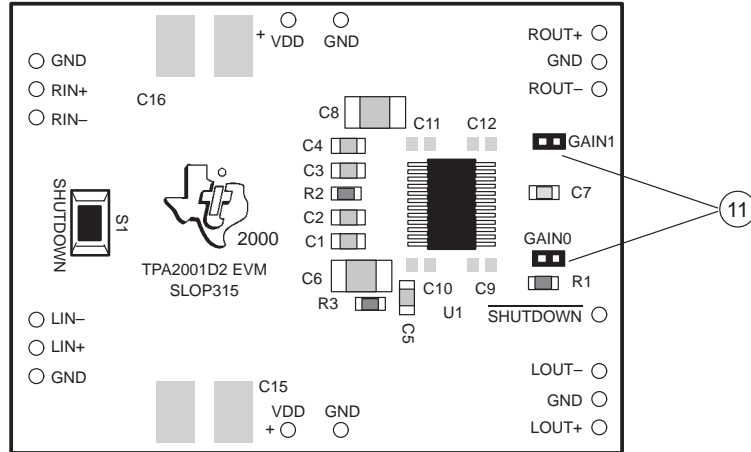

Table 2–4. Typical TPA2001D2 EVM Jumper Settings

GAIN1	GAIN0	GAIN (dB)
OFF	OFF	8
OFF	ON	12
ON	OFF	17.5
ON	ON	23.5

**Note:** ON = Jumper installed, OFF = Open, X = Don't care

**Power Up**

- 12) Verify correct voltage and input polarity and set the external power supply to **ON**. If  $V_{CC}$  and an onboard regulator EVM are used to provide  $V_{DD}$ , set platform power switch **S1** to **ON**.

Platform LED2 should light indicating the presence of  $V_{DD}$ , and the evaluation modules installed on the platform should begin operation.

- 13) Adjust the signal source level as needed.

## 2.3 Quick Start List for Stand-Alone

Follow these steps to use the TPA2001D2 EVM stand-alone or when connecting it into existing circuits or equipment. Connections to the TPA2001D2 module header pins can be made via individual sockets, wire-wrapping, or soldering to the pins, either on the top or the bottom of the module circuit board. Numbered callouts for selected steps are shown in Figure 2–3.

Figure 2–3. Quick Start Module Map

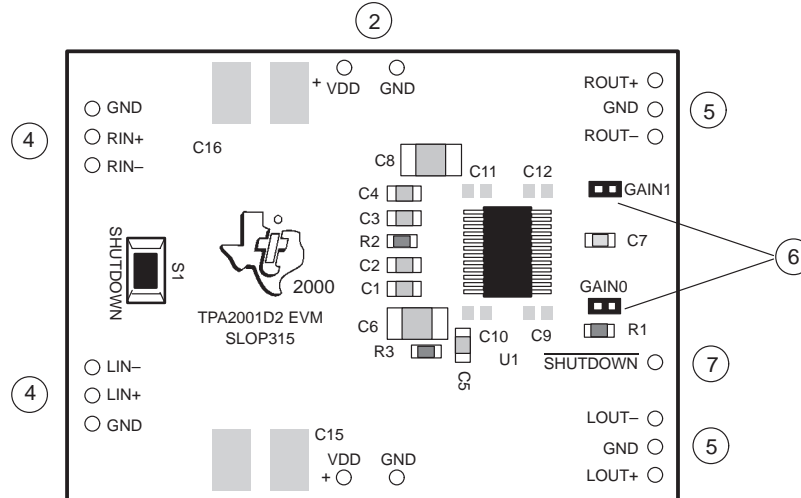

### Power supply

- 1) Ensure that all external power sources are set to **OFF**.
- 2) Connect an external regulated power supply set to 5 V to the module **VDD** and **GND** pins taking care to observe marked polarity.

### Inputs and outputs

- 3) Ensure that audio signal source level adjustments are set to minimum.
- 4) Connect the right (left) positive lead of the audio source to the module **RIN+** (**LIN+**) pins and the negative lead to the **RIN-** (**LIN-**) pins.
- 5) Connect the right (left) positive lead of the speaker to the module **ROUT+** (**LOUT+**) pins and the negative lead to the **ROUT-** (**LOUT-**) pins.

**Evaluation module preparations**

- 6) Use jumpers **GAIN0** and **GAIN1** to set the gain as shown in Table 2–5.

Table 2–5. TPA2001D2 EVM Gain Settings

GAIN1	GAIN0	GAIN (dB)
OFF	OFF	8
OFF	ON	12
ON	OFF	17.5
ON	ON	23.5

**Note:** ON = Jumper installed, OFF = Open, X = Don't care

**Control inputs**

- 7) **SHUTDOWN**: A low shuts down the amplifier IC on the module; a high or float allows normal operation.

**Power up**

- 8) Connect external power supply set to 5 V across the EVM **VDD** and **GND** pins.
- 9) Verify correct voltage and input polarity and set the external power supply to **ON**.

The EVM should begin operation.

- 10) Adjust the signal source level as needed.

## 2.4 Reference

### 2.4.1 TPA2001D2 EVM Connected for Stereo Output

Figure 2–4. TPA2001D2 EVM Connected for Stereo Output

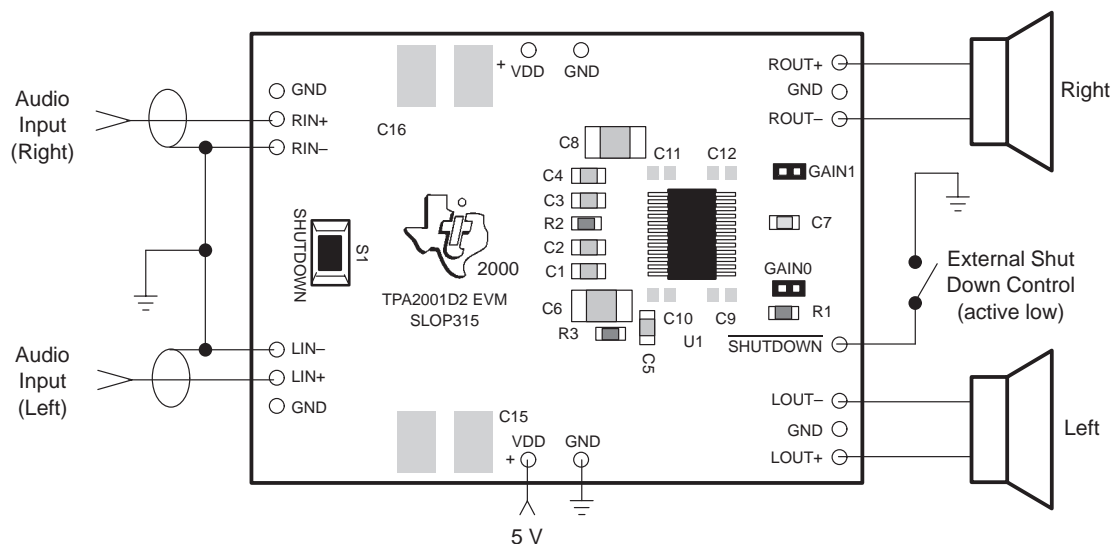

## 2.4.2 TPA2001D2 Audio Power Amplifier Evaluation Module Parts List

Table 2–6. TPA2001D2 EVM Parts List

Reference	Description	Size	EVM Qty.	Manufacturer/ Part Number
C1–4, C17–21	Capacitor, ceramic chip, 0.1 $\mu$ F, $\pm$ 10%, X7R, 50 V	0805	9	Kemet C0805C104K5RAC
C5	Capacitor, ceramic, 1.0 $\mu$ F, 80%/–20%, Y5V, 16 V	0805	1	Murata GRM40-Y5V105Z16
C6, C8	Capacitor, ceramic, 10 $\mu$ F, 80%/–20%, Y5V, 16 V	1210	2	Murata GRM235-Y5V106Z16
C7	Capacitor, ceramic, 220 pF, $\pm$ 10%, XICON, 50 V	0805	2	Mouser 140-CC501B221K
C9 – C12†	Not assembled	0805		
C15, C16†	Not assembled	1210		
C13, C14	Reference designators not used			
R1 – R4	Resistor, chip, 120 k $\Omega$ , 1/10 W, 5%, XICON	0805	4	Mouser 260-120K
S1	Switch, momentary pushbutton, 12 V, 50 mA	0.291 $\times$ 0.138 $\times$ 0.134"	1	Panasonic EVQ-PJS04K
GAIN0, GAIN1	Header, 2 position	2 mm	2	Norcomp DigiKey # 2163-02-ND
	Shunts	2 mm	2	3M
	Headers, 0.1 in centers, 1/2 in long	0.5 $\times$ 0.25 $\times$ 0.1"	17	Samtec T SW-19-8-G-S
U1	IC, TPA2001D2, audio power amplifier, 2-W, 2-channel, class-D	24 pin TSSOP	1	TI TPA2001D2PWP
PCB	PCB, TPA2001D2 EVM	2.25 X 1.5"	1	TI SLOP315

† Capacitors C9 – C12, C15, and C16 are optional (not assembled) and pad locations for them on the EVM PCB have been provided to increase design flexibility.

### 2.4.3 TPA2001D2 Filterless Class-D EVM Schematic

The TPA2001D2 filterless class-D EVM schematic is shown in Figure 2–5.

Figure 2–5. TPA2001D2 Class-D EVM Schematic Diagram

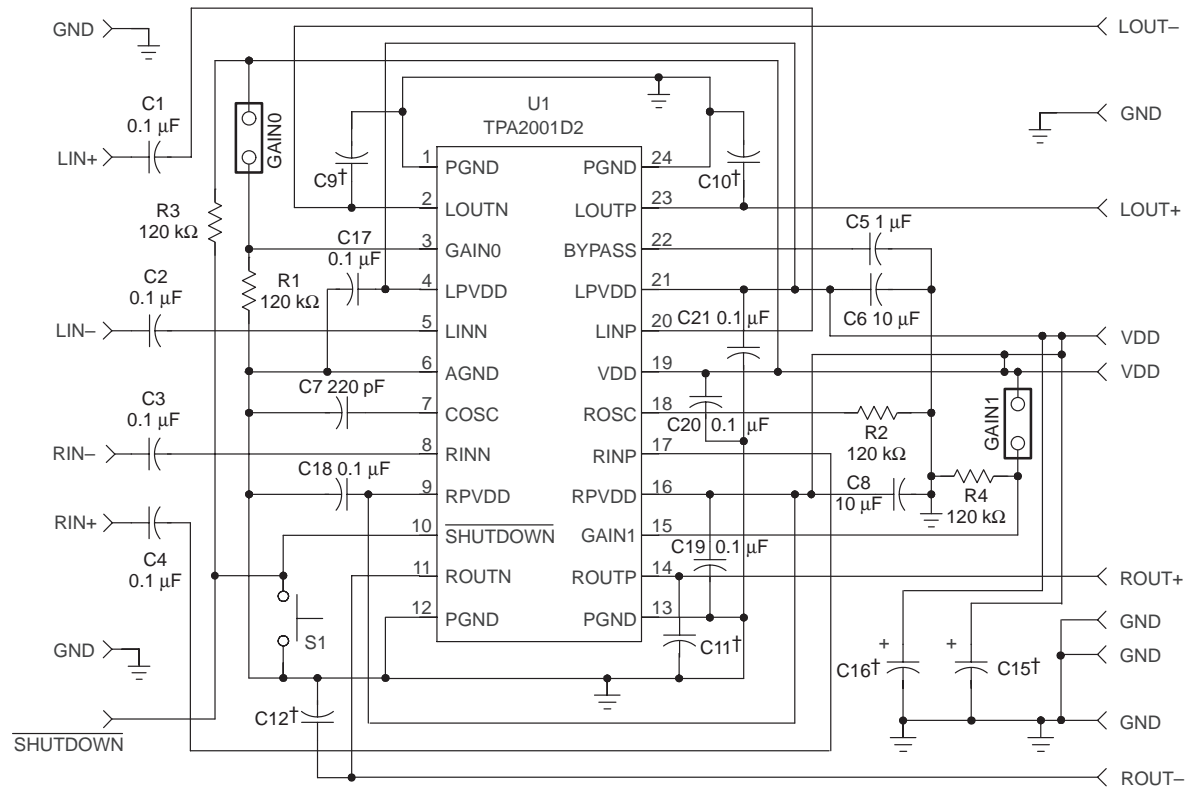

† Capacitors C9 – C12, C15, and C16 are optional (not assembled) and pad locations for them on the EVM PCB have been provided to increase design flexibility.

### 2.4.4 TPA2001D2 Filterless Class-D EVM PCB Layers

The following illustrations depict the TPA2001D2 filterless class-D EVM PCB assembly and layers. These drawings are not to scale. Gerber plots can be obtained from any TI Sales Office.

Figure 2–6. TPA2001D2 Filterless Class-D EVM Top Assembly

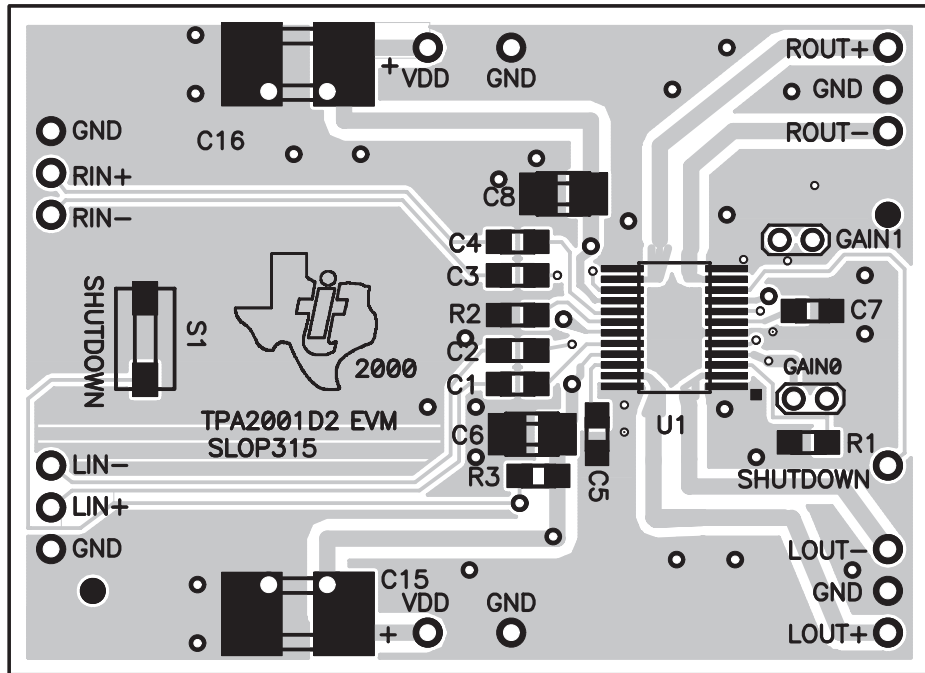

Figure 2–7. TPA2001D2 Filterless Class-D EVM Bottom Assembly

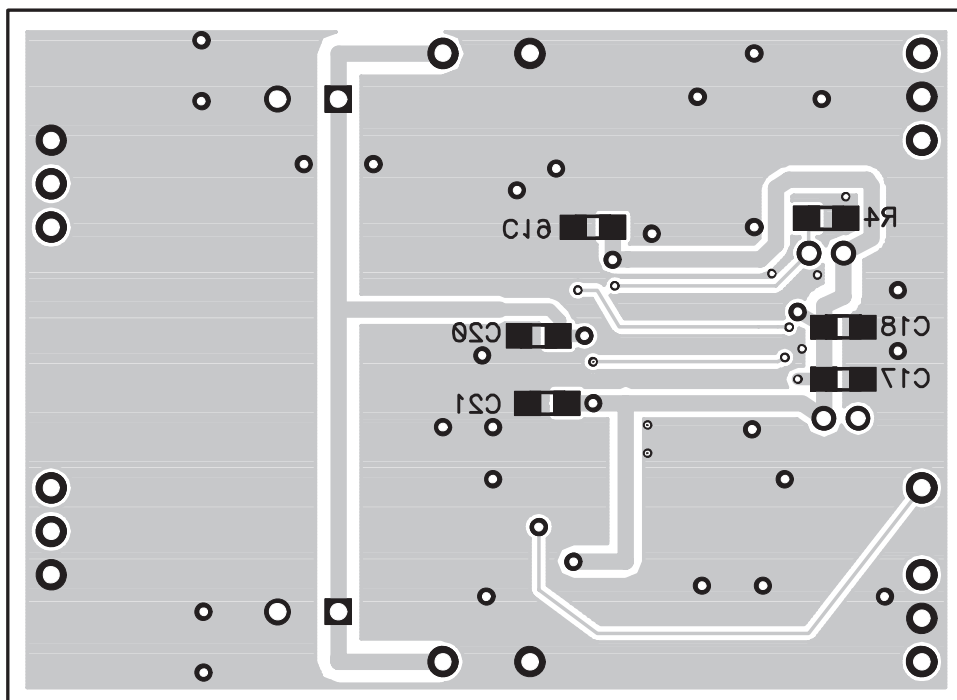

Figure 2–8. TPA2001D2 Filterless Class-D EVM Top Layer

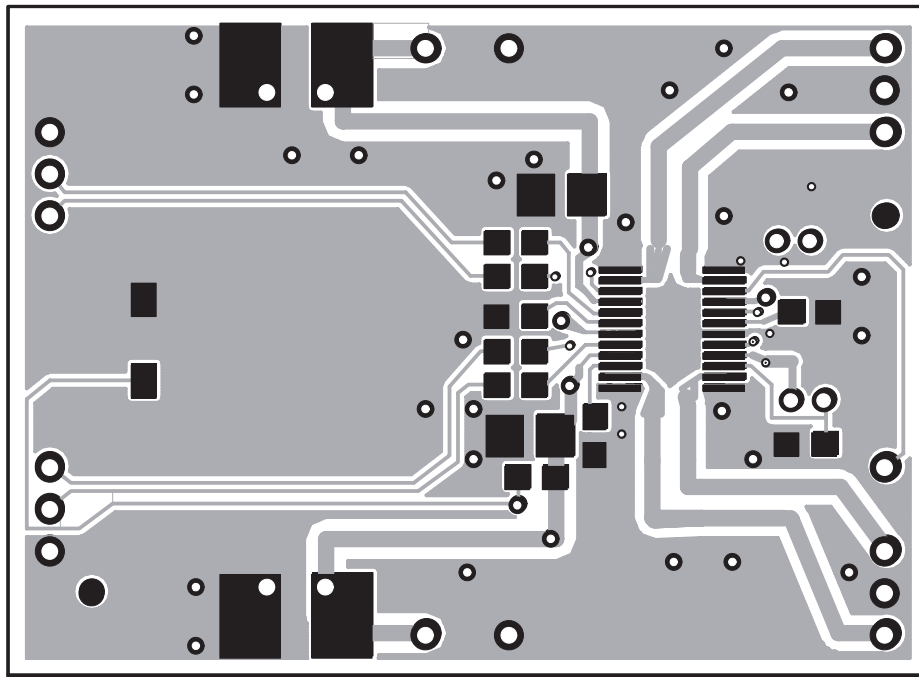
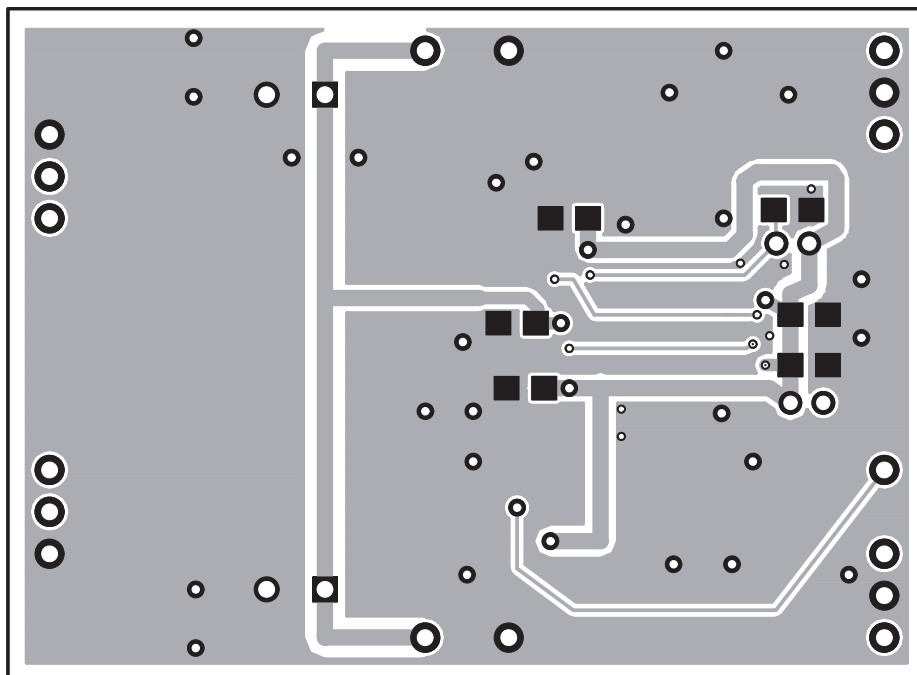

Figure 2–9. TPA2001D2 Filterless Class-D EVM Bottom Layer



## Looking for pricing, stock, or lifecycle information?

Click below to explore more details on WIN SOURCE:

 [View TPA2001D2EVM](#) on WIN SOURCE

 [Texas Instruments](#) Information

## Optimize Your Supply Chain with WIN SOURCE Solutions

-  Global Sourcing Solution
-  Obsolete Management
-  Cost Control Management
-  Shortage Management
-  Alternative Solution
-  Excess Inventory Management