



**THE DATASHEET OF  
DS3691MX/NOPB**



## DS3691 (RS-422/RS-423) Line Drivers with TRI-STATE Outputs

 Check for Samples: [DS1691A](#), [DS3691](#)

### FEATURES

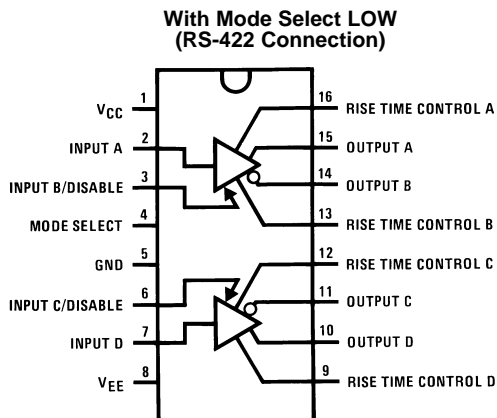
- Dual RS-422 Line Driver with Mode Pin Low, or Quad RS-423 Line Driver with Mode Pin High
- TRI-STATE Outputs in RS-422 Mode
- Short Circuit Protection for Both Source and Sink Outputs
- Outputs Will Not Clamp Line with Power Off or In TRI-STATE
- 100Ω Transmission Line Drive Capability
- Low  $I_{CC}$  and  $I_{EE}$  Power Consumption
  - RS-422:  $I_{CC} = 9$  mA/driver Typ
  - RS-423:  $I_{CC} = 4.5$  mA/driver Typ
  - $I_{EE} = 2.5$  mA/driver Typ
- Low Current PNP Inputs Compatible with TTL, MOS and CMOS
- Pin Compatible with AM26LS30

### DESCRIPTION

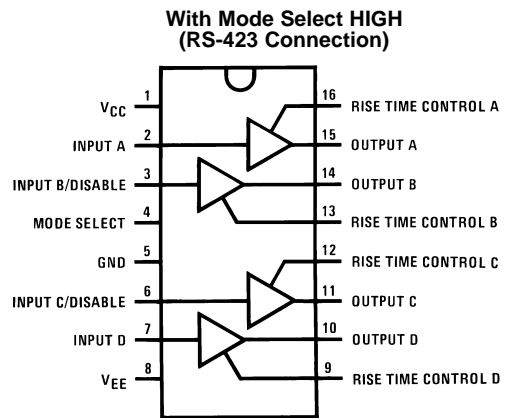
The DS3691 is a low power Schottky TTL line driver designed to meet the requirements of EIA standards RS-422 and RS-423. It features 4 buffered outputs with high source and sink current capability with internal short circuit protection. A mode control input provides a choice of operation either as 4 single-ended line drivers or 2 differential line drivers. A rise time control pin allows the use of an external capacitor to slow the rise time for suppression of near end crosstalk to other receivers in the cable. Rise time capacitors are primarily intended for waveshaping output signals in the single-ended driver mode. Multipoint applications in differential mode with waveshaping capacitors is not allowed.

With the mode select pin low, the DS3691 are dual-differential line drivers with TRI-STATE outputs. They feature  $\pm 10V$  output common-mode range in TRI-STATE mode and 0V output unbalance when operated with  $\pm 5V$  supply.

### Connection Diagrams



**Figure 1. SOIC Package  
See Package Number D0016A  
Top View**



**Figure 2. SOIC Package  
See Package Number D0016A  
Top View**



These devices have limited built-in ESD protection. The leads should be shorted together or the device placed in conductive foam during storage or handling to prevent electrostatic damage to the MOS gates.



Please be aware that an important notice concerning availability, standard warranty, and use in critical applications of Texas Instruments semiconductor products and disclaimers thereto appears at the end of this data sheet.

All trademarks are the property of their respective owners.

**Absolute Maximum Ratings**<sup>(1)(2)</sup>

Supply Voltage	V <sub>CC</sub>	7V
	V <sub>EE</sub>	-7V
Maximum Power Dissipation at 25°C SOIC Package <sup>(3)</sup>		1051 mW
Input Voltage		15V
Output Voltage (Power OFF)		±15V
Storage Temperature		-65°C to + 150°C
Lead Temperature (Soldering, 4 seconds)		260°C

- (1) "Absolute Maximum Ratings" are those values beyond which the safety of the device cannot be verified. They are not meant to imply that the devices should be operated at these limits. The tables of "Electrical Characteristics" provide conditions for actual device operation.
- (2) If Military/Aerospace specified devices are required, please contact the Texas Instruments Sales Office/ Distributors for availability and specifications.
- (3) Derate SOIC package 8.41 mW/°C above 25°C.

**Operating Conditions**

		Min	Max	Units
Supply Voltage	V <sub>CC</sub>	4.75	5.25	V
	V <sub>EE</sub>	-4.75	-5.25	V
Temperature, T <sub>A</sub>		0	+70	°C

**DC Electrical Characteristics<sup>(1)(2)(3)(4)</sup>**

Parameter		Test Conditions		Min	Typ	Max	Units
<b>RS-422 CONNECTION, V<sub>EE</sub> CONNECTION TO GROUND, MODE SELECT ≤ 0.8V</b>							
V <sub>IH</sub>	High Level Input Voltage			2			V
V <sub>IL</sub>	Low Level Input Voltage					0.8	V
I <sub>IH</sub>	High Level Input Current	V <sub>IN</sub> = 2.4V			1	40	μA
		V <sub>IN</sub> ≤ 15V			10	100	μA
I <sub>IL</sub>	Low Level Input Current	V <sub>IN</sub> = 0.4V			-30	-200	μA
V <sub>I</sub>	Input Clamp Voltage	I <sub>IN</sub> = -12 mA				-1.5	V
V <sub>O</sub> V <sub>O</sub>	Differential Output Voltage V <sub>A,B</sub>	R <sub>L</sub> = ∞	V <sub>IN</sub> = 2V		3.6	6.0	V
			V <sub>IN</sub> = 0.8V		-3.6	-6.0	V
V <sub>T</sub> V <sub>T</sub>	Differential Output Voltage V <sub>A,B</sub>	R <sub>L</sub> = 100Ω V <sub>CC</sub> ≥ 4.75V	V <sub>IN</sub> = 2V	2	2.4		V
			V <sub>IN</sub> = 0.8V	-2	-2.4		V
V <sub>OS</sub> , V <sub>OS</sub>	Common-Mode Offset Voltage	R <sub>L</sub> = 100Ω			2.5	3	V
V <sub>T</sub>   -  V <sub>T</sub>	Difference in Differential Output Voltage	R <sub>L</sub> = 100Ω			0.05	0.4	V
V <sub>OS</sub>   -  V <sub>OS</sub>	Difference in Common-Mode Offset Voltage	R <sub>L</sub> = 100Ω			0.05	0.4	V
V <sub>SS</sub>	V <sub>T</sub> - V <sub>T</sub>	R <sub>L</sub> = 100Ω, V <sub>CC</sub> ≥ 4.75V		4.0	4.8		V
V <sub>CMR</sub>	Output Voltage Common-Mode Range	V <sub>DISABLE</sub> = 2.4V		±10			V
I <sub>XA</sub>	Output Leakage Current	V <sub>CC</sub> = 0V	V <sub>CMR</sub> = 10V			100	μA
I <sub>XB</sub>	Power OFF		V <sub>CMR</sub> = -10V			-100	μA
I <sub>OX</sub>	TRI-STATE Output Current	V <sub>CC</sub> = Max V <sub>EE</sub> = 0V and -5V	V <sub>CMR</sub> ≤ 10V			100	μA
			V <sub>CMR</sub> ≥ -10V			-100	μA
I <sub>SA</sub>	Output Short Circuit Current	V <sub>IN</sub> = 0.4V	V <sub>OA</sub> = 6V		80	150	mA
			V <sub>OB</sub> = 0V		-80	-150	mA
I <sub>SB</sub>	Output Short Circuit Current	V <sub>IN</sub> = 2.4V	V <sub>OA</sub> = 0V		-80	-150	mA
			V <sub>OB</sub> = 6V		80	150	mA
I <sub>CC</sub>	Supply Current				18	30	mA

- (1) Unless otherwise specified, min/max limits apply across the -55°C to +125°C temperature range for the DS1691A and across the 0°C to +70°C range for the DS3691. All typicals are given for V<sub>CC</sub> = 5V and T<sub>A</sub> = 25°C. V<sub>CC</sub> and V<sub>EE</sub> as listed in operating conditions.
- (2) All currents into device pins are positive; all currents out of device pins are negative. All voltages are referenced to ground unless otherwise specified.
- (3) Only one output at a time should be shorted.
- (4) Symbols and definitions correspond to EIA RS-422 and/or RS-423 where applicable.

**AC Electrical Characteristics<sup>(1)</sup>**

 T<sub>A</sub> = 25°C

Parameter		Test Conditions		Min	Typ	Max	Units
<b>RS-422 CONNECTION, V<sub>CC</sub> = 5V, MODE SELECT = 0.8V</b>							
t <sub>r</sub>	Output Rise Time	R <sub>L</sub> = 100Ω, C <sub>L</sub> = 500 pF <a href="#">Figure 3</a>			120	200	ns
t <sub>f</sub>	Output Fall Time	R <sub>L</sub> = 100Ω, C <sub>L</sub> = 500 pF <a href="#">Figure 3</a>			120	200	ns
t <sub>PDH</sub>	Output Propagation Delay	R <sub>L</sub> = 100Ω, C <sub>L</sub> = 500 pF <a href="#">Figure 3</a>			120	200	ns
t <sub>PDL</sub>	Output Propagation Delay	R <sub>L</sub> = 100Ω, C <sub>L</sub> = 500 pF <a href="#">Figure 3</a>			120	200	ns
t <sub>PZL</sub>	TRI-STATE Delay	R <sub>L</sub> = 450Ω, C <sub>L</sub> = 500 pF, C <sub>C</sub> = 0 pF <a href="#">Figure 6</a>			250	350	ns
t <sub>PZH</sub>	TRI-STATE Delay	R <sub>L</sub> = 450Ω, C <sub>L</sub> = 500 pF, C <sub>C</sub> = 0 pF <a href="#">Figure 6</a>			180	300	ns
t <sub>PLZ</sub>	TRI-STATE Delay	R <sub>L</sub> = 450Ω, C <sub>L</sub> = 500 pF, C <sub>C</sub> = 0 pF <a href="#">Figure 6</a>			180	300	ns
t <sub>PHZ</sub>	TRI-STATE Delay	R <sub>L</sub> = 450Ω, C <sub>L</sub> = 500 pF, C <sub>C</sub> = 0 pF <a href="#">Figure 6</a>			250	350	ns

- (1) Symbols and definitions correspond to EIA RS-422 and/or RS-423 where applicable.

**DC Electrical Characteristics**<sup>(1)(2)(3)(4)</sup>

Parameter		Test Conditions		Min	Typ	Max	Units
<b>RS-423 CONNECTION, <math> V_{CC}  =  V_{EE} </math>, MODE SELECT <math>\geq 2V</math></b>							
$V_{IH}$	High Level Input Voltage			2			V
$V_{IL}$	Low Level Input Voltage					0.8	V
$I_{IH}$	High Level Input Current	$V_{IN} = 2.4V$			1	40	$\mu A$
		$V_{IN} \leq 15V$			10	100	$\mu A$
$I_{IL}$	Low Level Input Current	$V_{IN} = 0.4V$			-30	-200	$\mu A$
$V_I$	Input Clamp Voltage	$I_{IN} = -12 mA$				-1.5	V
$\frac{V_O}{V_O}$	Output Voltage	$R_L = \infty$ , See <sup>(5)</sup> $V_{CC} \geq 4.75V$	$V_{IN} = 2V$	4.0	4.4	6.0	V
			$V_{IN} = 0.4V$	-4.0	-4.4	-6.0	V
$\frac{V_T}{V_T}$	Output Voltage	$R_L = 450\Omega$ $V_{CC} \geq 4.75V$	$V_{IN} = 2.4V$	3.6	4.1		V
			$V_{IN} = 0.4V$	-3.6	-4.1		V
$ V_T  -  \overline{V_T} $	Output Unbalance	$ V_{CC}  =  V_{EE}  = 4.75V$ , $R_L = 450\Omega$			0.02	0.4	V
$I_{X^+}$	Output Leakage Power OFF	$V_{CC} = V_{EE} = 0V$	$V_O = 6V$		2	100	$\mu A$
$I_{X^-}$	Output Leakage Power OFF	$V_{CC} = V_{EE} = 0V$	$V_O = -6V$		-2	-100	$\mu A$
$I_{S^+}$	Output Short Circuit Current	$V_O = 0V$	$V_{IN} = 2.4V$		-80	-150	mA
$I_{S^-}$	Output Short Circuit Current	$V_O = 0V$	$V_{IN} = 0.4V$		80	150	mA
$I_{SLEW}$	Slew Control Current				$\pm 140$		$\mu A$
$I_{CC}$	Positive Supply Current	$V_{IN} = 0.4V$ , $R_L = \infty$			18	30	mA
$I_{EE}$	Negative Supply Current	$V_{IN} = 0.4V$ , $R_L = \infty$			-10	-22	mA

- (1) Unless otherwise specified, min/max limits apply across the  $-55^\circ C$  to  $+125^\circ C$  temperature range for the DS1691A and across the  $0^\circ C$  to  $+70^\circ C$  range for the DS3691. All typicals are given for  $V_{CC} = 5V$  and  $T_A = 25^\circ C$ .  $V_{CC}$  and  $V_{EE}$  as listed in operating conditions.
- (2) All currents into device pins are positive; all currents out of device pins are negative. All voltages are referenced to ground unless otherwise specified.
- (3) Only one output at a time should be shorted.
- (4) Symbols and definitions correspond to EIA RS-422 and/or RS-423 where applicable.
- (5) At  $-55^\circ C$ , the output voltage is  $+3.9V$  minimum and  $-3.9V$  minimum.

**AC Electrical Characteristics**<sup>(1)</sup> $T_A = 25^\circ C$ 

Parameter		Test Conditions		Min	Typ	Max	Units
<b>RS-423 CONNECTION, <math>V_{CC} = 5V</math>, <math>V_{EE} = -5V</math>, MODE SELECT = 2.4V</b>							
$t_r$	Rise Time	$R_L = 450\Omega$ , $C_L = 500 pF$ , $C_C = 0$	<a href="#">Figure 4</a>		120	300	ns
$t_f$	Fall Time	$R_L = 450\Omega$ , $C_L = 500 pF$ , $C_C = 0$	<a href="#">Figure 4</a>		120	300	ns
$t_r$	Rise Time	$R_L = 450\Omega$ , $C_L = 500 pF$ , $C_C = 50 pF$	<a href="#">Figure 5</a>		3.0		$\mu s$
$t_f$	Fall Time	$R_L = 450\Omega$ , $C_L = 500 pF$ , $C_C = 50 pF$	<a href="#">Figure 5</a>		3.0		$\mu s$
$t_{rc}$	Rise Time Coefficient	$R_L = 450\Omega$ , $C_L = 500 pF$ , $C_C = 50 pF$	<a href="#">Figure 5</a>		0.06		$\mu s/pF$
$t_{PDH}$	Output Propagation Delay	$R_L = 450\Omega$ , $C_L = 500 pF$ , $C_C = 0$	<a href="#">Figure 4</a>		180	300	ns
$t_{PDL}$	Output Propagation Delay	$R_L = 450\Omega$ , $C_L = 500 pF$ , $C_C = 0$	<a href="#">Figure 4</a>		180	300	ns

- (1) Symbols and definitions correspond to EIA RS-422 and/or RS-423 where applicable.

AC Test Circuits and Switching Time Waveforms

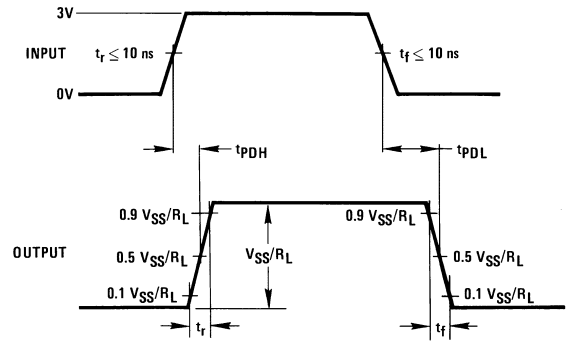
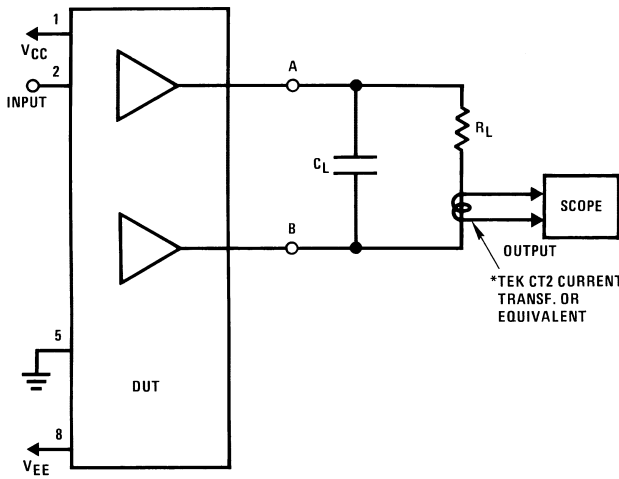


Figure 3. Differential Connection

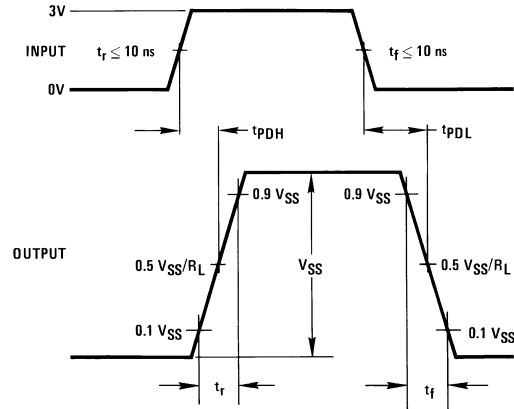
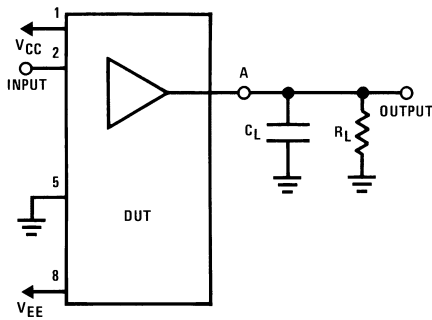
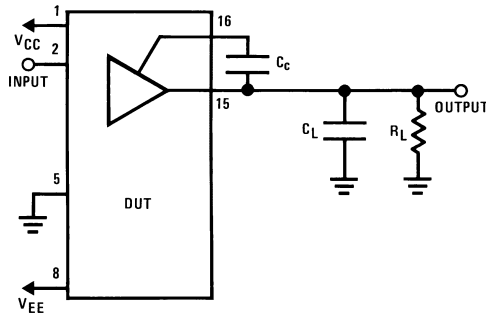


Figure 4. RS-423 Connection



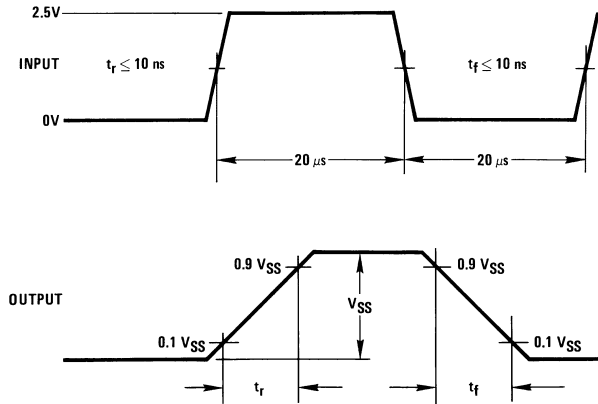


Figure 5. Rise Time Control for RS-423

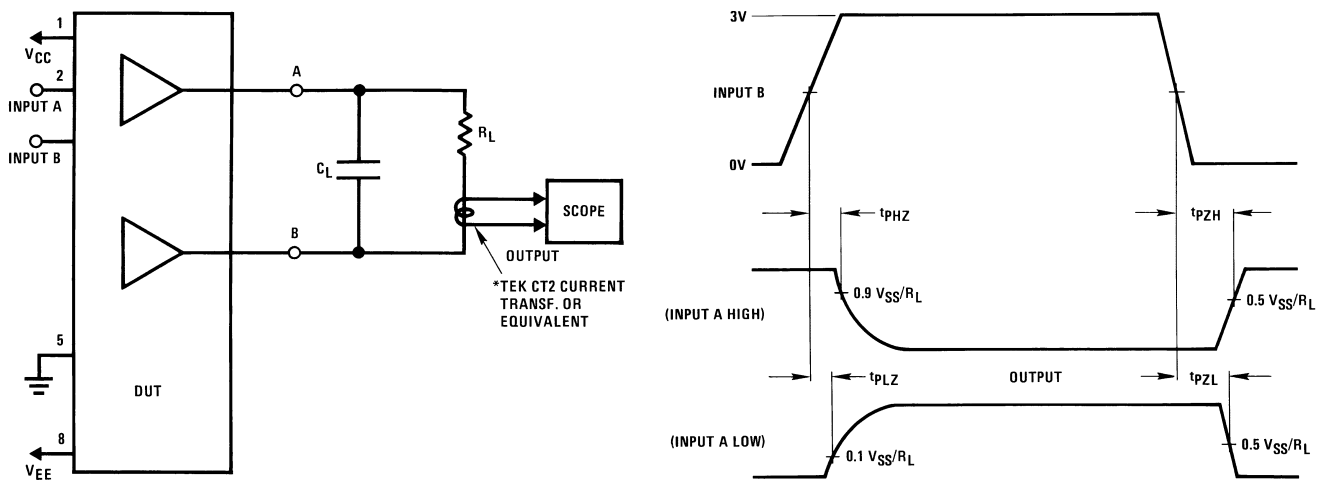


Figure 6. TRI-STATE Delays

SWITCHING WAVEFORMS

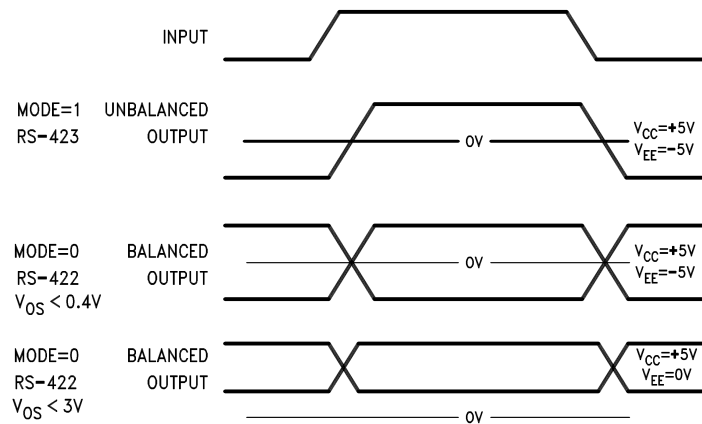
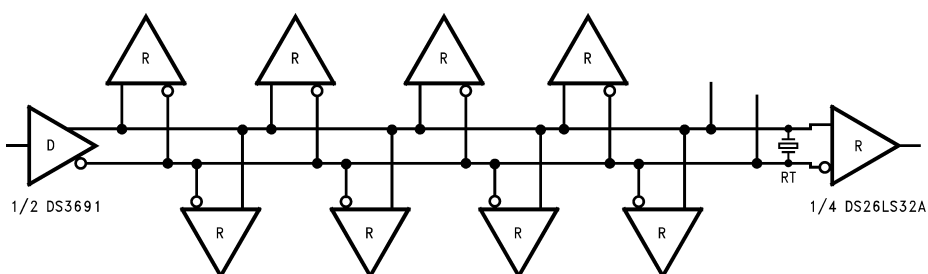


Figure 7. Typical Output Voltage

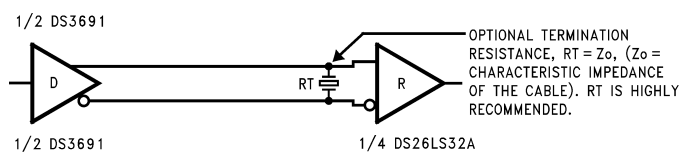
**Truth Table**

Operation	Inputs			Outputs	
	Mode	A (D)	B (C)	A (D)	B (C)
RS-422	0	0	0	0	1
	0	0	1	TRI-STATE	TRI-STATE
	0	1	0	1	0
	0	1	1	TRI-STATE	TRI-STATE
RS-423	1	0	0	0	0
	1	0	1	0	1
	1	1	0	1	0
	1	1	1	1	1

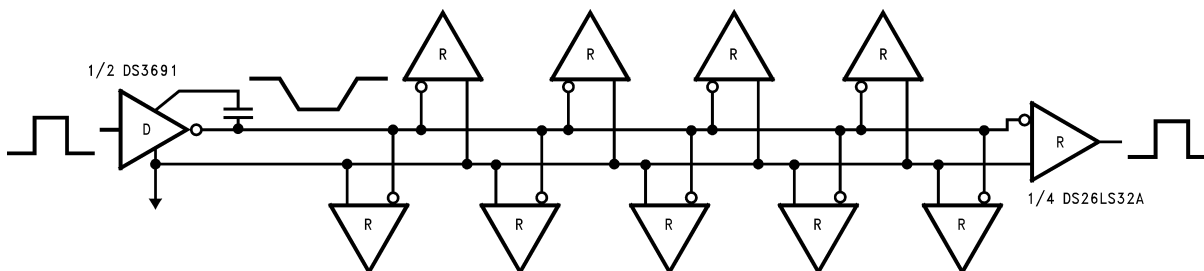
**TYPICAL APPLICATION INFORMATION**



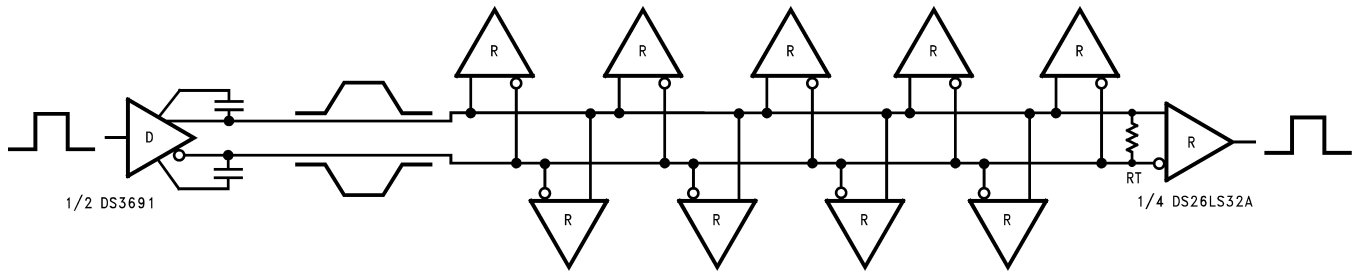
**Figure 8. Fully Loaded RS-422 Interface**



**Figure 9. RS-422 Point to Point Application**

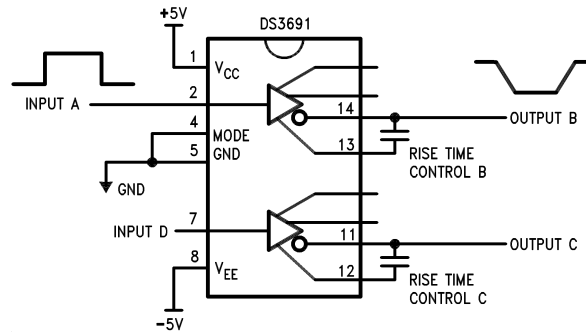


**Figure 10. Fully Loaded RS-423 Interface**



**\*Note:** Controlled edge allows longer stub lengths. Multiple Drivers are NOT allowed.

**Figure 11. Differential Application with Rise Time Control**

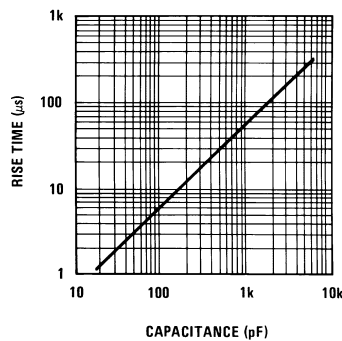


**Figure 12. Dual RS-423 Inverting Driver**

**Typical Rise Time Control Characteristics**

(RS-423 Mode)

**Rise Time vs External Capacitor**



**Figure 13.**

---

## REVISION HISTORY

Changes from Revision D (April 2013) to Revision E	Page
• Changed layout of National Data Sheet to TI format .....	<a href="#">8</a>

---

**PACKAGING INFORMATION**

Orderable Device	Status (1)	Package Type	Package Drawing	Pins	Package Qty	Eco Plan (2)	Lead/Ball Finish (6)	MSL Peak Temp (3)	Op Temp (°C)	Device Marking (4/5)	Samples
DS3691M	OBSOLETE	SOIC	D	16		TBD	Call TI	Call TI	0 to 70	DS3691M AM26LS30SC	
DS3691M/NOPB	ACTIVE	SOIC	D	16	48	Green (RoHS & no Sb/Br)	CU SN	Level-1-260C-UNLIM	0 to 70	DS3691M AM26LS30SC	<a href="#">Samples</a>
DS3691MX/NOPB	ACTIVE	SOIC	D	16	2500	Green (RoHS & no Sb/Br)	CU SN	Level-1-260C-UNLIM	0 to 70	DS3691M AM26LS30SC	<a href="#">Samples</a>

(1) The marketing status values are defined as follows:

**ACTIVE:** Product device recommended for new designs.

**LIFEBUY:** TI has announced that the device will be discontinued, and a lifetime-buy period is in effect.

**NRND:** Not recommended for new designs. Device is in production to support existing customers, but TI does not recommend using this part in a new design.

**PREVIEW:** Device has been announced but is not in production. Samples may or may not be available.

**OBSOLETE:** TI has discontinued the production of the device.

(2) Eco Plan - The planned eco-friendly classification: Pb-Free (RoHS), Pb-Free (RoHS Exempt), or Green (RoHS & no Sb/Br) - please check <http://www.ti.com/productcontent> for the latest availability information and additional product content details.

**TBD:** The Pb-Free/Green conversion plan has not been defined.

**Pb-Free (RoHS):** TI's terms "Lead-Free" or "Pb-Free" mean semiconductor products that are compatible with the current RoHS requirements for all 6 substances, including the requirement that lead not exceed 0.1% by weight in homogeneous materials. Where designed to be soldered at high temperatures, TI Pb-Free products are suitable for use in specified lead-free processes.

**Pb-Free (RoHS Exempt):** This component has a RoHS exemption for either 1) lead-based flip-chip solder bumps used between the die and package, or 2) lead-based die adhesive used between the die and leadframe. The component is otherwise considered Pb-Free (RoHS compatible) as defined above.

**Green (RoHS & no Sb/Br):** TI defines "Green" to mean Pb-Free (RoHS compatible), and free of Bromine (Br) and Antimony (Sb) based flame retardants (Br or Sb do not exceed 0.1% by weight in homogeneous material)

(3) MSL, Peak Temp. - The Moisture Sensitivity Level rating according to the JEDEC industry standard classifications, and peak solder temperature.

(4) There may be additional marking, which relates to the logo, the lot trace code information, or the environmental category on the device.

(5) Multiple Device Markings will be inside parentheses. Only one Device Marking contained in parentheses and separated by a "~" will appear on a device. If a line is indented then it is a continuation of the previous line and the two combined represent the entire Device Marking for that device.

(6) Lead/Ball Finish - Orderable Devices may have multiple material finish options. Finish options are separated by a vertical ruled line. Lead/Ball Finish values may wrap to two lines if the finish value exceeds the maximum column width.

**Important Information and Disclaimer:** The information provided on this page represents TI's knowledge and belief as of the date that it is provided. TI bases its knowledge and belief on information provided by third parties, and makes no representation or warranty as to the accuracy of such information. Efforts are underway to better integrate information from third parties. TI has taken and

continues to take reasonable steps to provide representative and accurate information but may not have conducted destructive testing or chemical analysis on incoming materials and chemicals. TI and TI suppliers consider certain information to be proprietary, and thus CAS numbers and other limited information may not be available for release.

In no event shall TI's liability arising out of such information exceed the total purchase price of the TI part(s) at issue in this document sold by TI to Customer on an annual basis.

## TAPE AND REEL INFORMATION



### QUADRANT ASSIGNMENTS FOR PIN 1 ORIENTATION IN TAPE



\*All dimensions are nominal

Device	Package Type	Package Drawing	Pins	SPQ	Reel Diameter (mm)	Reel Width W1 (mm)	A0 (mm)	B0 (mm)	K0 (mm)	P1 (mm)	W (mm)	Pin1 Quadrant
DS3691MX/NOPB	SOIC	D	16	2500	330.0	16.4	6.5	10.3	2.3	8.0	16.0	Q1

**TAPE AND REEL BOX DIMENSIONS**



\*All dimensions are nominal

Device	Package Type	Package Drawing	Pins	SPQ	Length (mm)	Width (mm)	Height (mm)
DS3691MX/NOPB	SOIC	D	16	2500	367.0	367.0	35.0

D (R-PDSO-G16)

PLASTIC SMALL OUTLINE



- NOTES:
- A. All linear dimensions are in inches (millimeters).
  - B. This drawing is subject to change without notice.
  - C. Body length does not include mold flash, protrusions, or gate burrs. Mold flash, protrusions, or gate burrs shall not exceed 0.006 (0,15) each side.
  - D. Body width does not include interlead flash. Interlead flash shall not exceed 0.017 (0,43) each side.
  - E. Reference JEDEC MS-012 variation AC.

## IMPORTANT NOTICE

Texas Instruments Incorporated and its subsidiaries (TI) reserve the right to make corrections, enhancements, improvements and other changes to its semiconductor products and services per JESD46, latest issue, and to discontinue any product or service per JESD48, latest issue. Buyers should obtain the latest relevant information before placing orders and should verify that such information is current and complete. All semiconductor products (also referred to herein as "components") are sold subject to TI's terms and conditions of sale supplied at the time of order acknowledgment.

TI warrants performance of its components to the specifications applicable at the time of sale, in accordance with the warranty in TI's terms and conditions of sale of semiconductor products. Testing and other quality control techniques are used to the extent TI deems necessary to support this warranty. Except where mandated by applicable law, testing of all parameters of each component is not necessarily performed.

TI assumes no liability for applications assistance or the design of Buyers' products. Buyers are responsible for their products and applications using TI components. To minimize the risks associated with Buyers' products and applications, Buyers should provide adequate design and operating safeguards.

TI does not warrant or represent that any license, either express or implied, is granted under any patent right, copyright, mask work right, or other intellectual property right relating to any combination, machine, or process in which TI components or services are used. Information published by TI regarding third-party products or services does not constitute a license to use such products or services or a warranty or endorsement thereof. Use of such information may require a license from a third party under the patents or other intellectual property of the third party, or a license from TI under the patents or other intellectual property of TI.

Reproduction of significant portions of TI information in TI data books or data sheets is permissible only if reproduction is without alteration and is accompanied by all associated warranties, conditions, limitations, and notices. TI is not responsible or liable for such altered documentation. Information of third parties may be subject to additional restrictions.

Resale of TI components or services with statements different from or beyond the parameters stated by TI for that component or service voids all express and any implied warranties for the associated TI component or service and is an unfair and deceptive business practice. TI is not responsible or liable for any such statements.

Buyer acknowledges and agrees that it is solely responsible for compliance with all legal, regulatory and safety-related requirements concerning its products, and any use of TI components in its applications, notwithstanding any applications-related information or support that may be provided by TI. Buyer represents and agrees that it has all the necessary expertise to create and implement safeguards which anticipate dangerous consequences of failures, monitor failures and their consequences, lessen the likelihood of failures that might cause harm and take appropriate remedial actions. Buyer will fully indemnify TI and its representatives against any damages arising out of the use of any TI components in safety-critical applications.

In some cases, TI components may be promoted specifically to facilitate safety-related applications. With such components, TI's goal is to help enable customers to design and create their own end-product solutions that meet applicable functional safety standards and requirements. Nonetheless, such components are subject to these terms.

No TI components are authorized for use in FDA Class III (or similar life-critical medical equipment) unless authorized officers of the parties have executed a special agreement specifically governing such use.

Only those TI components which TI has specifically designated as military grade or "enhanced plastic" are designed and intended for use in military/aerospace applications or environments. Buyer acknowledges and agrees that any military or aerospace use of TI components which have **not** been so designated is solely at the Buyer's risk, and that Buyer is solely responsible for compliance with all legal and regulatory requirements in connection with such use.

TI has specifically designated certain components as meeting ISO/TS16949 requirements, mainly for automotive use. In any case of use of non-designated products, TI will not be responsible for any failure to meet ISO/TS16949.

### Products

Audio	<a href="http://www.ti.com/audio">www.ti.com/audio</a>
Amplifiers	<a href="http://amplifier.ti.com">amplifier.ti.com</a>
Data Converters	<a href="http://dataconverter.ti.com">dataconverter.ti.com</a>
DLP® Products	<a href="http://www.dlp.com">www.dlp.com</a>
DSP	<a href="http://dsp.ti.com">dsp.ti.com</a>
Clocks and Timers	<a href="http://www.ti.com/clocks">www.ti.com/clocks</a>
Interface	<a href="http://interface.ti.com">interface.ti.com</a>
Logic	<a href="http://logic.ti.com">logic.ti.com</a>
Power Mgmt	<a href="http://power.ti.com">power.ti.com</a>
Microcontrollers	<a href="http://microcontroller.ti.com">microcontroller.ti.com</a>
RFID	<a href="http://www.ti-rfid.com">www.ti-rfid.com</a>
OMAP Applications Processors	<a href="http://www.ti.com/omap">www.ti.com/omap</a>
Wireless Connectivity	<a href="http://www.ti.com/wirelessconnectivity">www.ti.com/wirelessconnectivity</a>

### Applications

Automotive and Transportation	<a href="http://www.ti.com/automotive">www.ti.com/automotive</a>
Communications and Telecom	<a href="http://www.ti.com/communications">www.ti.com/communications</a>
Computers and Peripherals	<a href="http://www.ti.com/computers">www.ti.com/computers</a>
Consumer Electronics	<a href="http://www.ti.com/consumer-apps">www.ti.com/consumer-apps</a>
Energy and Lighting	<a href="http://www.ti.com/energy">www.ti.com/energy</a>
Industrial	<a href="http://www.ti.com/industrial">www.ti.com/industrial</a>
Medical	<a href="http://www.ti.com/medical">www.ti.com/medical</a>
Security	<a href="http://www.ti.com/security">www.ti.com/security</a>
Space, Avionics and Defense	<a href="http://www.ti.com/space-avionics-defense">www.ti.com/space-avionics-defense</a>
Video and Imaging	<a href="http://www.ti.com/video">www.ti.com/video</a>

### TI E2E Community

[e2e.ti.com](http://e2e.ti.com)

## Looking for pricing, stock, or lifecycle information?

Click below to explore more details on WIN SOURCE:

 [View DS3691MX/NOPB on WIN SOURCE](#)

 [Texas Instruments](#) Information

## Optimize Your Supply Chain with WIN SOURCE Solutions

-  Global Sourcing Solution
-  Obsolete Management
-  Cost Control Management
-  Shortage Management
-  Alternative Solution
-  Excess Inventory Management