



**THE DATASHEET OF  
PI6CB18200ZDIEX**



**PI6CB18200**

**Very Low Power 2-Output PCIe Clock Buffer**

**Description**

The DIODES PI6CB18200 is an 2-output very low power PCIe® Gen1/Gen2/Gen3/Gen4 clock buffer. It takes an reference input to fanout two 100MHz low power differential HCSL outputs. Individual OE pin for each output provides easier power management.

It uses Diodes proprietary PLL design to achieve very low jitter that meets PCIe Gen1/Gen2/Gen3/Gen4 requirements. Other than PCIe 100MHz support, this device also support Ethernet application with 50MHz or 125MHz via SMBus. It provides various options such as different slew rate and amplitude through strapping pins or SMBUS so that users can configure the device easily to get the optimized performance for their individual boards.

**Block Diagram**

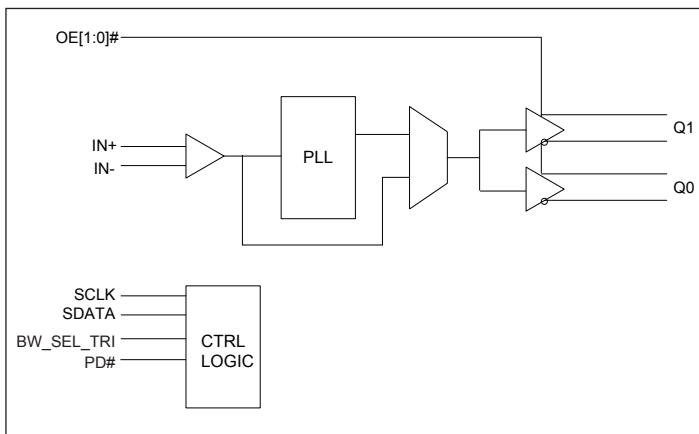

**Features**

- 1.8V Supply Voltage
- HCSL Input: 100MHz, also support 50MHz or 125MHz via SMBus
- 2 Differential Low Power HCSL Outputs
- Individual Output Enable
- Programmable Slew Rate and Output Amplitude for each output
- Differential Outputs blocked until PLL is locked
- Strapping Pins or SMBus for Configuration
- 3.3V Tolerant SMBus Interface Support
- Very Low Jitter Outputs
  - Differential Cycle-to-cycle Jitter <50ps
  - Differential Output-to-output Skew <50ps
  - PCIe Gen1/Gen2/Gen3/Gen4 Compliant
- Totally Lead-Free & Fully RoHS Compliant (Notes 1 & 2)
- Halogen and Antimony Free. “Green” Device (Note 3)
- For automotive applications requiring specific change control (i.e. parts qualified to AEC-Q100/101/104/200, PPAP capable, and manufactured in IATF 16949 certified facilities), please [contact us](https://www.diodes.com/quality/product-definitions/) or your local Diodes representative.
- Packaging (Pb-free & Green):
  - 24-lead 4x4mm TQFN

**Notes:**

1. No purposely added lead. Fully EU Directive 2002/95/EC (RoHS), 2011/65/EU (RoHS 2) & 2015/863/EU (RoHS 3) compliant.
2. See <https://www.diodes.com/quality/lead-free/> for more information about Diodes Incorporated’s definitions of Halogen- and Antimony-free, "Green" and Lead-free.
3. Halogen- and Antimony-free "Green" products are defined as those which contain <900ppm bromine, <900ppm chlorine (<1500ppm total Br + Cl) and <1000ppm antimony compounds.

## Pin Configuration

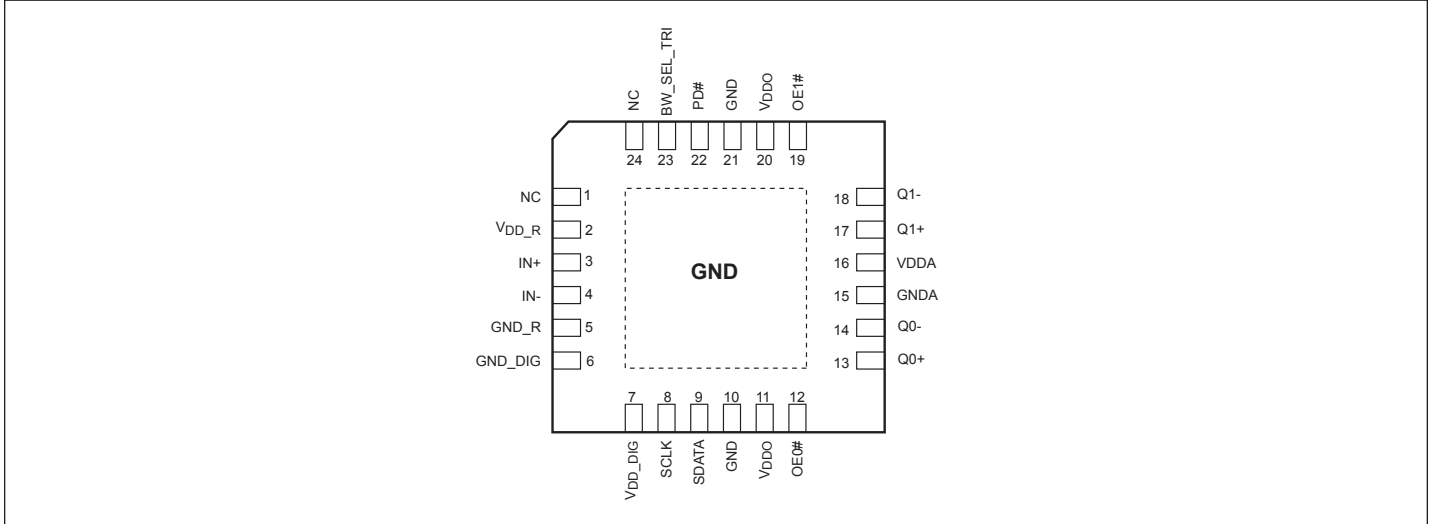

## Pin Description

Pin Number	Pin Name	Type		Description
1, 24	NC			Internal connected for feedback loop. Do not connect this pin
2	V <sub>DD_R</sub>	Power		Power supply for input differential buffers
3	IN+	Input		Differential true clock input
4	IN-	Input		Differential complementary clock input
5	GND <sub>R</sub>	Power		Ground for input differential buffers
6	GND <sub>DIG</sub>	Power		Ground for digital circuitry
7	V <sub>DD_DIG</sub>	Power		Power supply for digital circuitry, nominal 1.8V
8	SCLK	Input	CMOS	SMBUS clock input, 3.3V tolerant
9	SDATA	Input/ Output	CMOS	SMBUS Data line, 3.3V tolerant
10, 21	GND	Power		Ground
11, 20	V <sub>DDO</sub>	Power		Power supply for differential outputs
12	OE0#	Input	CMOS	Active low input for enabling Q0 pair. This pin has an internal pull-down. 1 =disable outputs, 0 = enable outputs
13	Q0+	Output	HCSL	Differential true clock output
14	Q0-	Output	HCSL	Differential complementary clock output
15	GNDA	Power		Ground for analog circuitry
16	V <sub>DDA</sub>	Power		Power supply for analog circuitry
17	Q1+	Output	HCSL	Differential true clock output
18	Q1-	Output	HCSL	Differential complementary clock output
19	OE1#	Input	CMOS	Active low input for enabling Q1 pair. This pin has an internal pull-down. 1 =disable outputs, 0 = enable outputs

**PI6CB18200**

Pin Number	Pin Name	Type		Description
22	PD#	Input	CMOS	Input notifies device to sample latched inputs and start up on first high assertion. Low enters Power Down Mode, subsequent high assertions exit Power Down Mode. This pin has internal pull-up resistor.
23	BW_SEL_TRI	Input	Tri-level	Latch to select low loop bandwidth, bypass PLL, and high loop bandwidth. This pin has both internal pull-up and pull-down

**Power Management Table**

PD#	IN	SMBus OE bit	OEn#	Qn+	Qn-	PLL Status
0	X	X	X	Low	Low	Off
1	Running	0	X	Low	Low	On <sup>(1)</sup>
1	Running	1	0	Running	Running	On <sup>(1)</sup>
1	Running	1	1	Low	Low	On <sup>(1)</sup>

Note:

1. If PLL Bypass mode is selected, the PLL will be off and outputs will be running.

**PLL Operating Mode Select Table**

BW_SEL_TRI	Operating Mode	Byte1 [7:6] Readback	Byte1 [4:3] Readback
0	PLL with low Bandwidth	00	00
M	PLL Bypass	01	01
1	PLL with high Bandwidth	11	11

**Frequency Select Table**

Freq. Select Byte 3 [4:3]	IN (MHz)	Qn (MHz)
00 (default)	100	100
01	50	50
10	125	125
11	Reserved	Reserved

**SMBUS Address**

Address	+ Read/ Write bit
1101101	x

## Maximum Ratings

(Above which useful life may be impaired. For user guidelines, not tested.)

Storage Temperature.....	-65°C to +150°C
Junction Temperature .....	up to +125°C
Supply Voltage to Ground Potential, $V_{DDXX}$ .....	-0.5V to +2.5V
Input Voltage .....	-0.5V to $V_{DD}+0.5V$ , not exceed 2.5V
SMBus, Input High Voltage .....	3.6V
ESD Protection (HBM) .....	2000V

**Note:**

Stresses greater than those listed under MAXIMUM RATINGS may cause permanent damage to the device. This is a stress rating only and functional operation of the device at these or any other conditions above those indicated in the operational sections of this specification is not implied. Exposure to absolute maximum rating conditions for extended periods may affect reliability.

## Operating Conditions

Temperature =  $T_A$ ; Supply voltages per normal operation conditions; See test circuits for the load conditions

Symbol	Parameters	Conditions	Min.	Typ.	Max.	Units
$V_{DD}, V_{DDA}, V_{DD\_R}, V_{DD\_DIG}$	Power Supply Voltage		1.7	1.8	1.9	V
$V_{DDO}$	Output Power Supply Voltage		1.7	1.8	1.9	V
$I_{DDA}$	Analog Power Supply Current	$V_{DDA} + V_{DD\_R}$ , PLL mode, All outputs active @100MHz		4.5	6	mA
$I_{DD}$	Power Supply Current	$V_{DD} + V_{DD\_DIG}$ , All outputs active @100MHz		8	10	mA
$I_{DDO}$	Power Supply Current for Outputs	All outputs active @100MHz		6	8	mA
$I_{DDA\_PD}$	Analog Power Supply Power Down <sup>(1)</sup> Current	$V_{DDA} + V_{DD\_R}$ , PLL mode, All outputs active @100MHz		0.7	1	mA
$I_{DD\_PD}$	Power Supply Power Down <sup>(1)</sup> Current	$V_{DD} + V_{DD\_DIG} + V_{DDO}$ , All outputs LOW/LOW			1.4	mA
$T_A$	Ambient Temperature	Industrial grade	-40		85	°C

**Note:**

1. Input clock is not running.

## Input Electrical Characteristics

Symbol	Parameters	Conditions	Min.	Typ.	Max.	Units
$R_{pu}$	Internal pull up resistance			120		K $\Omega$
$R_{dn}$	Internal pull down resistance			120		K $\Omega$
$L_{PIN}$	Pin inductance				7	nH

## SMBus Electrical Characteristics

Temperature =  $T_A$ ; Supply voltages per normal operation conditions; See test circuits for the load conditions

Symbol	Parameters	Conditions	Min.	Typ.	Max.	Units
$V_{DDSMB}$	Nominal bus voltage		1.7		3.6	V
$V_{IHSMB}$	SMBus Input High Voltage	SMBus, $V_{DDSMB} = 3.3V$	2.1		3.6	V
		SMBus, $V_{DDSMB} < 3.3V$	0.65 $V_{DDSMB}$			
$V_{ILSMB}$	SMBus Input Low Voltage	SMBus, $V_{DDSMB} = 3.3V$			0.6	V
		SMBus, $V_{DDSMB} < 3.3V$			0.6	
$I_{SMBSINK}$	SMBus sink current	SMBus, at $V_{OLSMB}$	4			mA
$V_{OLSMB}$	SMBus Output Low Voltage	SMBus, at $I_{SMBSINK}$			0.4	V
$f_{MAXSMB}$	SMBus operating frequency	Maximum frequency			400	kHz
$t_{RMSB}$	SMBus rise time	(Max $V_{IL} - 0.15$ ) to (Min $V_{IH} + 0.15$ )			1000	ns
$t_{FMSB}$	SMBus fall time	(Min $V_{IH} + 0.15$ ) to (Max $V_{IL} - 0.15$ )			300	ns

## LVC MOS DC Electrical Characteristics

Temperature =  $T_A$ ; Supply voltages per normal operation conditions; See test circuits for the load conditions

Symbol	Parameters	Conditions	Min.	Typ.	Max.	Units
$V_{IH}$	Input High Voltage	Single-ended inputs, except SMBus	0.75 $V_{DD}$		$V_{DD} + 0.3$	V
$V_{IM}$	Input Mid Voltage	BW_SEL_TRI	0.4 $V_{DD}$	0.5 $V_{DD}$	0.6 $V_{DD}$	V
$V_{IL}$	Input Low Voltage	Single-ended inputs, except SMBus	-0.3		0.25 $V_{DD}$	V
$I_{IH}$	Input High Current	Single-ended inputs, $V_{IN} = V_{DD}$			20	$\mu A$
$I_{IL}$	Input Low Current	Single-ended inputs, $V_{IN} = 0V$	-20			$\mu A$
$I_{IH}$	Input High Current	Single-ended inputs with pull up / pull down resistor, $V_{IN} = V_{DD}$			220	$\mu A$
$I_{IL}$	Input Low Current	Single-ended inputs with pull up / pull down resistor, $V_{IN} = 0V$	-220			$\mu A$
$C_{IN}$	Input Capacitance		1.5		5	pF

## LVC MOS AC Electrical Characteristics

Temperature =  $T_A$ ; Supply voltages per normal operation conditions; See test circuits for the load conditions

Symbol	Parameters	Conditions	Min.	Typ.	Max.	Units
$t_{OELAT}$	Output enable latency	Q start after OE# assertion Q stop after OE# deassertion	1		3	clocks
$t_{PDLAT}$	PD# de-assertion	Differential outputs enable after PD# de-assertion		20	300	us

## HCSL Input Characteristics<sup>(1)</sup>

Temperature = T<sub>A</sub>; Supply voltages per normal operation conditions; See test circuits for the load conditions

Symbol	Parameters	Conditions	Min.	Typ.	Max.	Units
V <sub>IHDIF</sub>	Diff. Input High Voltage <sup>(3)</sup>	IN+, IN-, single-end measurement	600	800	1150	mV
V <sub>ILDIF</sub>	Diff. Input Low Voltage <sup>(3)</sup>	IN+, IN-, single-end measurement	-300	0	300	mV
V <sub>COM</sub>	Diff. Input Common Mode Voltage		150		1000	mV
V <sub>SWING</sub>	Diff. Input Swing Voltage	Peak to peak value (V <sub>IHDIF</sub> - V <sub>ILDIF</sub> )	300		1450	mV
f <sub>INBP</sub>	Input Frequency	PLL Bypass mode	1		200	MHz
f <sub>IN100</sub>	Input Frequency	100MHz PLL	60	100	110	MHz
f <sub>IN125</sub>	Input Frequency	125MHz PLL	75	125	137.5	MHz
f <sub>IN156</sub>	Input Frequency	50MHz PLL	30	50	65	MHz
t <sub>STAB</sub>	Clock stabilization	From V <sub>DD</sub> Power-Up and after input clock stabilization or de-assertion of PD# to 1st clock		0.6	1.0	ms
t <sub>RF</sub>	Diff. Input Slew Rate <sup>(2)</sup>	Measured differentially	0.4			V/ns
I <sub>IN</sub>	Diff. Input Leakage Current	V <sub>IN</sub> = V <sub>DD</sub> , V <sub>IN</sub> = GND	-5	0.01	5	uA
t <sub>DC</sub>	Diff. Input Duty Cycle	Measured differentially	45		55	%
t <sub>j-c-c</sub>	Diff. Input Cycle to cycle jitter	Measured differentially			125	ps

**Note:**

1. Guaranteed by design and characterization, not 100% tested in production
2. Slew rate measured through +/-75mV window centered around differential zero
3. The device can be driven by a single-ended clock by driving the true clock and biasing the complement clock input to the V<sub>bias</sub>, where V<sub>bias</sub> is (V<sub>IH</sub>-V<sub>IL</sub>)/2

## HCSL Output Characteristics

Temperature = T<sub>A</sub>; Supply voltages per normal operation conditions; See test circuits for the load conditions

Symbol	Parameters	Condition	Min.	Typ.	Max.	Units
V <sub>OH</sub>	Output Voltage High <sup>(1)</sup>	Statistical measurement on single-ended signal using oscilloscope math function	660	774	900	mV
V <sub>OL</sub>	Output Voltage Low <sup>(1)</sup>		-150		150	mV
V <sub>OMAX</sub>	Output Voltage Maximum <sup>(1)</sup>	Measurement on single ended signal using absolute value		821	1150	mV
V <sub>OMIN</sub>	Output Voltage Minimum <sup>(1)</sup>		-300	-15		mV
V <sub>O</sub> SWING	Output Swing Voltage <sup>(1,2,3)</sup>	Scope averaging off	300	1536		mV
V <sub>OC</sub>	Output Cross Voltage <sup>(1,2,4)</sup>		250	430	550	mV
DV <sub>OC</sub>	V <sub>OC</sub> Magnitude Change <sup>(1,2,5)</sup>			12	140	mV

**Note:**

1. At default SMBUS amplitude settings
2. Guaranteed by design and characterization, not 100% tested in production
3. Measured from differential waveform
4. This one is defined as voltage where Q+ = Q- measured on a component test board and only applied to the differential rising edge
5. The total variation of all V<sub>cross</sub> measurements in any particular system. This is a subset of V<sub>cross\_min/max</sub> allowed.

## HCSSL Output AC Characteristics

Temperature = T<sub>A</sub>; Supply voltages per normal operation conditions; See test circuits for the load conditions

Symbol	Parameters	Condition	Min.	Typ.	Max.	Units
f <sub>OUT</sub>	Output Frequency			100		MHz
BW	PLL bandwidth <sup>(1,8)</sup>	-3dB point in High Bandwidth Mode	2	2.7	4	MHz
		-3dB point in Low Bandwidth Mode	1	1.4	2	MHz
t <sub>jpeak</sub>	PLL Jitter Peaking	Peak pass band gain		1.2	2	dB
t <sub>RF</sub>	Slew rate <sup>(1,2,3)</sup>	Scope averaging on fast setting	2.2	3.0	6	V/ns
		Scope averaging on slow setting	0.4	2	3	V/ns
D <sub>tRF</sub>	Slew rate matching <sup>(1,2,4)</sup>	Scope averaging on		7	20	%
t <sub>SKEW</sub>	Output Skew <sup>(1,2)</sup>	Averaging on, V <sub>T</sub> = 50%		43	50	ps
t <sub>PDELAY</sub>	Properagation delay	PLL Bypass mode, V <sub>T</sub> = 50%	2800	3600	4500	ps
		PLL mode, V <sub>T</sub> = 50%	0	90	200	ps
t <sub>jC-C</sub>	Cycle to cycle jitter <sup>(1,2)</sup>			14	50	ps
t <sub>jPHASE</sub>	Integrated phase jitter (RMS) <sup>(1,5,6)</sup>	PCIe Gen 1	20	22	86	ps
		PCIe Gen 2 Low Band, 10kHz < f < 1.5MHz	0.2	0.3	3.0	ps
		PCIe Gen 2 High Band, 1.5MHz < f < Nyquist (50MHz)	1.6	2.0	3.1	ps
		PCIe Gen 3 (PLL BW of 2-4 or 2-5MHz, CDR =10MHz)	0.3	0.35	1.0	ps
		PCIe Gen 4 (PLL BW of 2-4 or 2-5MHz, CDR =10MHz)	0.2	0.3	0.5	ps
		125MHz, 1.5MHz to 20MHz, -20dB/decade Rollover < 1.5MHz, -40dB/decade rolloff > 10MHz <sup>(9)</sup>		1.9	2	ps
t <sub>jPHASEA</sub>	Additive Integrated phase jitter (RMS) <sup>(1,5,10)</sup>	PCIe Gen 1		0.6	5	ps
		PCIe Gen 2 Low Band, 10kHz < f < 1.5MHz		0.1	0.3	ps
		PCIe Gen 2 High Band, 1.5MHz < f < Nyquist (50MHz)		0.05	0.1	ps
		PCIe Gen 3 (PLL BW of 2-4 or 2-5MHz, CDR =10MHz)		0.05	0.1	ps
		PCIe Gen 4 (PLL BW of 2-4 or 2-5MHz, CDR =10MHz) (BW_SEL_TRI=M)		0.03	0.05	ps
		125MHz, 1.5MHz to 20MHz, -20dB/decade Rollover < 1.5MHz, -40dB/decade rolloff > 10MHz		0.15	0.3	ps
t <sub>DC</sub>	Duty Cycle <sup>(1,2)</sup>	Measured differentially, PLL Mode	45	50	55	%
t <sub>DCCD</sub>	Duty Cycle Distortion <sup>(1,7)</sup>	Measured differentially, PLL Bypass Mode at 100MHz	-1	0	1	%
t <sub>STARTUP</sub>	Start up time				10	ms

**PI6CB18200**

Symbol	Parameters	Condition	Min.	Typ.	Max.	Units
t <sub>LOCK</sub>	PLL lock time				20	ms

**Note:**

1. Guaranteed by design and characterization, not 100% tested in production
2. Measured from differential waveform
3. Slew rate is measured through the Vswing voltage range centered around differential 0V, within +/-150mV window
4. Slew rate matching is measured using a +/-75mV window centered on differential zero
5. See <http://www.pcisig.com> for complete specs
6. Sample size of at least 100k cycles. This can be extrapolated to 108ps pk-pk @ 1M cycles for a BER of 10<sup>-12</sup>
7. Duty cycle distortion is the difference in duty cycle between the out and input clock when the device is operated in the PLL bypass mode
8. The Min and Max values of each BW setting track each other, low BW max will never occur with high BW min
9. Applies to all differential outputs
10. For additive jitter RMS value is calculated by the following equation =  $\text{SQRT} [(\text{total jitter})^2 - (\text{input jitter})^2]$

## SMBus Serial Data Interface

The PI6CB18200 is a slave only device that supports block read and block write protocol using a single 7-bit address and read/write bit as shown below.

Read and write block transfers can be stopped after any complete byte transfer.

### Address Assignment

A6	A5	A4	A3	A2	A1	A0	R/W
1	1	0	1	1	0	1	1/0

Note: SMBus address is DA in hex.

### How to Write

1 bit	7 bits	1 bit	1 bit	8 bits	1 bit	8 bits	1 bit	8 bits	1 bit	8 bits	1 bit	1 bit	
Start bit	Add.	W(0)	Ack	Beginning Byte location = N	Ack	Data Byte count = X	Ack	Beginning Data Byte (N)	Ack	.....	Data Byte (N+X-1)	Ack	Stop bit

### How to Read

1 bit	7 bits	1 bit	1 bit	8 bits	1 bit	1 bit	7 bits	1 bit	1 bit	8 bits	1 bit	8 bits	1 bit
Start bit	Address	W(0)	Ack	Beginning Byte location = N	Ack	Repeat Start bit	Address	R(1)	Ack	Data Byte count = X	Ack	Beginning Data Byte (N)	Ack

	8 bits	1 bit	1 bit
.....	Data Byte (N+X-1)	NAck	Stop bit

### Byte 0: Output Enable Register<sup>(1)</sup>

Bit	Control Function	Description	Type	Power Up Condition	0	1
7	Reserved			1		
6	Reserved			1		
5	Q1_OE	Q1 output enable	RW	1	Low/Low	Enabled
4	Reserved			1		
3	Q0_OE	Q0 output enable	RW	1	Low/Low	Enabled
2	Reserved			1		
1	Reserved			1		
0	Reserved			1		

**Note:**

1. A low on these bits will override the OE# pins and force the differential outputs to Low/Low states

### Byte 1: PLL Operating Mode and Output Amplitude Control Register

Bit	Control Function	Description	Type	Power Up Condition	0	1
7	PLLMODERB1	PLL Mode Readback Bit1	R	Latch	See PLL Operating Mode Table	
6	PLLMODERB0	PLL Mode Readback Bit0	R	Latch		
5	PLLMODE_SWCTR	Enable SW control of PLL Mode	RW	0	Values in B1[7:6] set PLL Mode	Values in B1[4:3] set PLL Mode
4	PLLMODE1	PLL Mode control Bit1	RW <sup>(1)</sup>	0	See PLL Operating Mode Table	
3	PLLMODE0	PLL Mode control Bit0	RW <sup>(1)</sup>	0		
2	Reserved			1		
1	Amplitude1	Control output amplitude	RW	1	'00' = 0.6V, '01' = 0.7V, '10' = 0.8V, '11' = 0.9V	
0	Amplitude0		RW	0		

**Note:**

1. B1[5] must be set to a 1 for these bits to have any effect on the part

### Byte 2: Differential Output Slew Rate Control Register

Bit	Control Function	Description	Type	Power Up Condition	0	1
7	Reserved			1		
6	Reserved			1		
5	SLEWRATECTR_Q1	Control slew rate of Q1	RW	1	Slow setting	Fast setting
4	Reserved			1		
3	SLEWRATECTR_Q0	Control slew rate of Q0	RW	1	Slow setting	Fast setting
2	Reserved			1		
1	Reserved			1		
0	Reserved			1		

### Byte 3: Frequency Select Control Register

Bit	Control Function	Description	Type	Power Up Condition	0	1
7	Reserved			1		
6	Reserved			1		
5	FREQ_SEL_EN	Enable SW selection of frequency	RW	0	SW Freq. selection disabled	SW Freq. selection enabled
4	FSEL1	Freq. Select Bit 1	RW <sup>(1)</sup>	0	See Frequency Select Table	
3	FSEL0	Freq. Select Bit 0	RW <sup>(1)</sup>	0		
2	Reserved			1		
1	Reserved			1		
0	SLEWRATESEL_FB	Adjust Slew Rate of Feedback signal	RW	1	2.0V/ns	3.0V/ns

**Note:**

1. B1[5] must be set to a 1 for these bits to have any effect on the part

### Byte 4: Reserved

Bit	Control Function	Description	Type	Power Up Condition	0	1
7:0	Reserved			1		

### Byte 5: Revision and Vendor ID Register

Bit	Control Function	Description	Type	Power Up Condition	0	1
7	RID3	Revision ID	R	0	rev = 0000	
6	RID2		R	0		
5	RID1		R	0		
4	RID0		R	0		
3	PVID3	Vendor ID	R	0	Diodes = 0011	
2	PVID2		R	0		
1	PVID1		R	1		
0	PVID0		R	1		

### Byte 6: Device Type/Device ID Register

Bit	Control Function	Description	Type	Power Up Condition	0	1
7	DTYPE1	Device type	R	0	'00' = CG, '01' = ZDB, '10' = Reserve, '11' = ZDB	
6	DTYPE0		R	1		
5	DID5	Device ID	R	0	000010 binary, 02Hex	
4	DID4		R	0		
3	DID3		R	0		
2	DID2		R	0		
1	DID1		R	1		
0	DID0		R	0		

### Byte 7: Byte Count Register

Bit	Control Function	Description	Type	Power Up Condition	0	1
7	Reserved			0		
6	Reserved			0		
5	Reserved			0		
4	BC4	Byte count programming	RW	0	Writing to this register will configure how many bytes will be read back, default is 8 bytes	
3	BC3		RW	1		
2	BC2		RW	0		
1	BC1		RW	0		
0	BC0		RW	0		

**Plots**

**100MHz HCSL Clock**

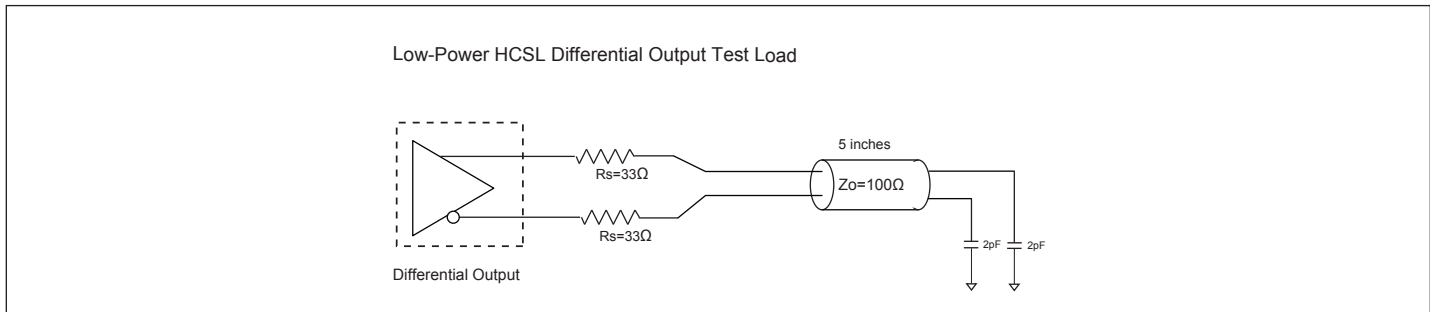
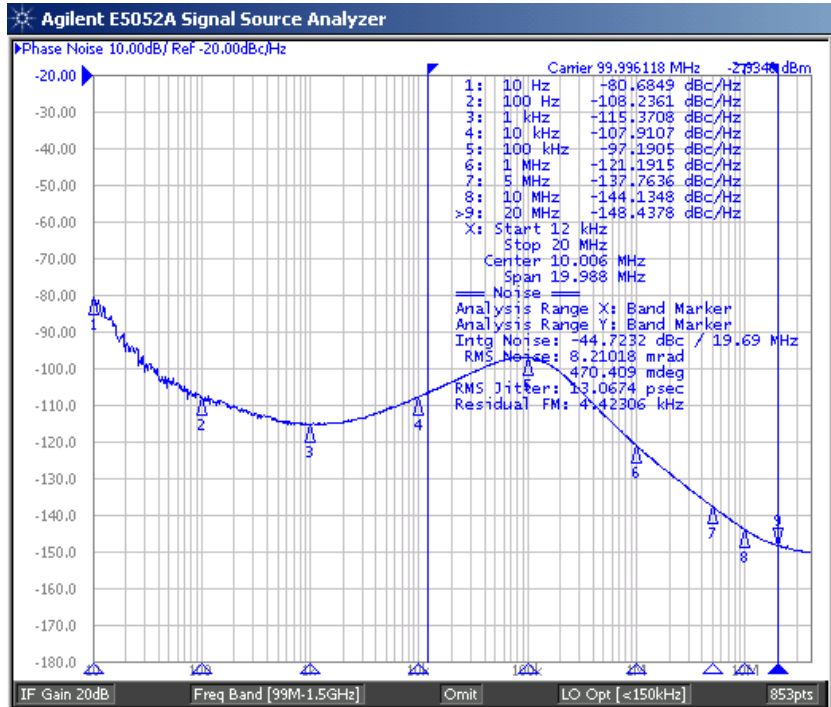

**Figure 1. Low Power HCSL Test Circuit**

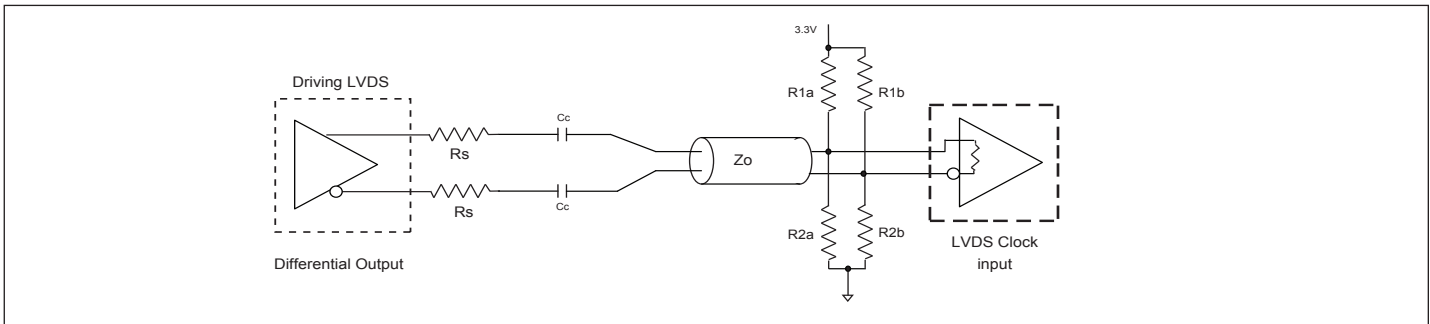
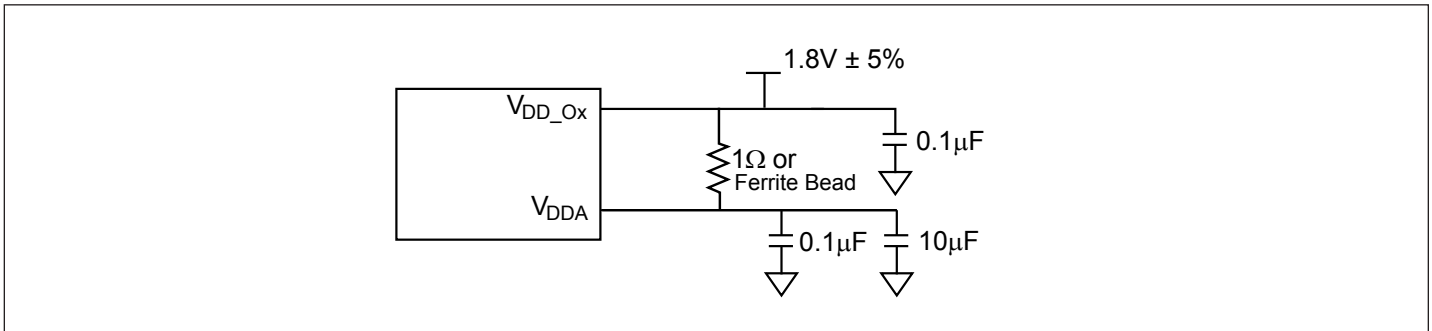

**Figure 2. Differential Output Driving LVDS**

**PI6CB18200**

**Alternate Differential Output Terminations**

Component	Receiver with termination	Receiver without termination	Unit
R <sub>1a</sub> , R <sub>1b</sub>	10,000	140	Ω
R <sub>2a</sub> , R <sub>2b</sub>	5,600	75	Ω
C <sub>C</sub>	0.1	0.1	μF
V <sub>CM</sub>	1.2	1.2	V



**Figure 3. Power Supply Filter**

**Part Marking**

PI6CB18  
 200ZDIE  
 ZYYWWXX  
 ○

Z: Die Rev  
 Y: Year  
 W: Workweek  
 1st X: Assembly Code  
 2nd X: Fab Code

**Packaging Mechanical**

**24-TQFN (ZD)**

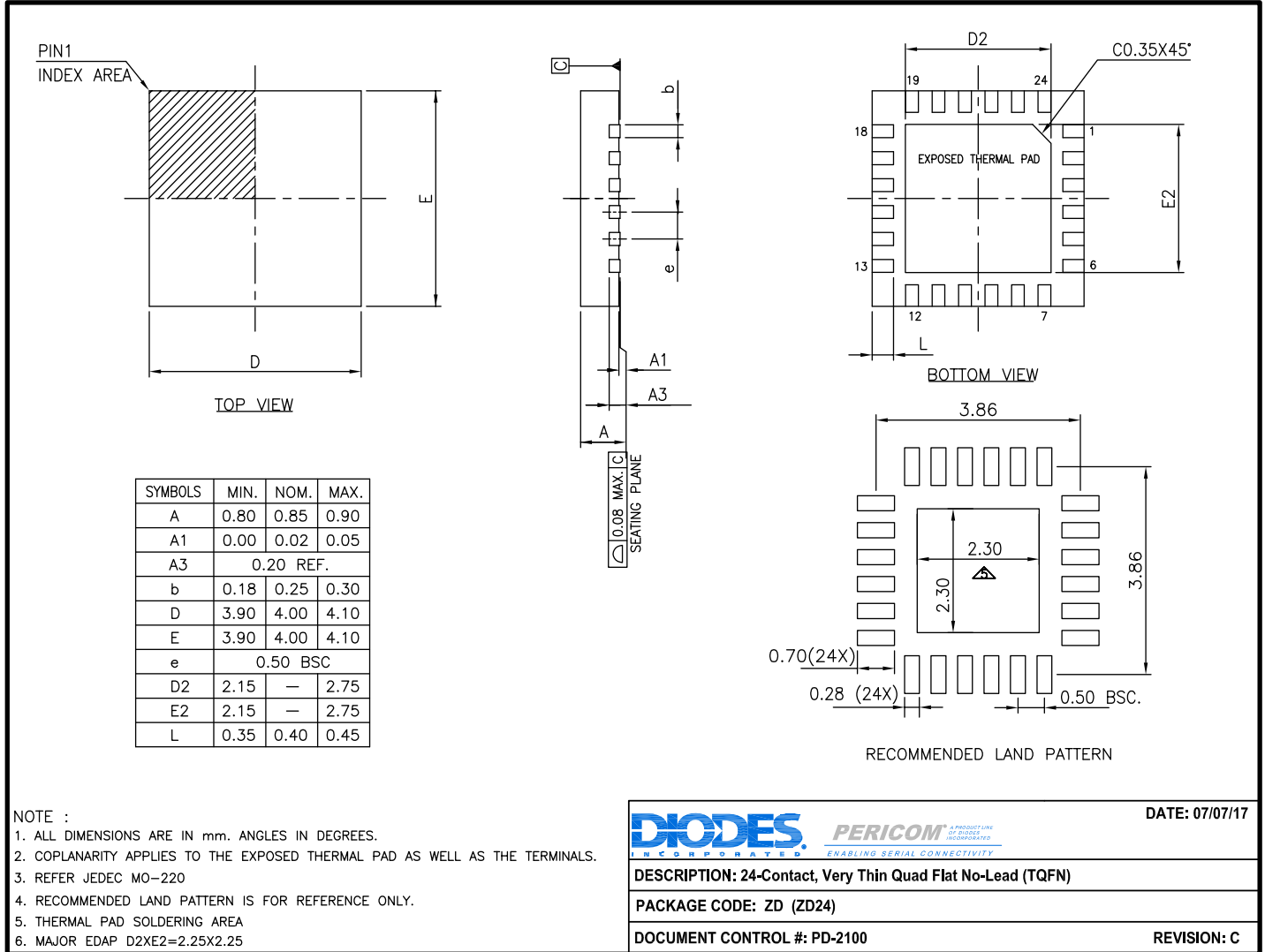

17-0533

For latest package info.

please check: <http://www.diodes.com/design/support/packaging/pericom-packaging/packaging-mechanicals-and-thermal-characteristics/>

**Ordering Information**

Ordering Code	Package Code	Package Description	Pin 1 Location
PI6CB18200ZDIEX	ZD	24-Contact, Very Thin Quad Flat No-Lead (TQFN)	Top Right Corner
PI6CB18200ZDIEX-13R	ZD	24-Contact, Very Thin Quad Flat No-Lead (TQFN)	Top Left Corner

**Notes:**

- No purposely added lead. Fully EU Directive 2002/95/EC (RoHS), 2011/65/EU (RoHS 2) & 2015/863/EU (RoHS 3) compliant.
- See <https://www.diodes.com/quality/lead-free/> for more information about Diodes Incorporated's definitions of Halogen- and Antimony-free, "Green" and Lead-free.
- Halogen- and Antimony-free "Green" products are defined as those which contain <900ppm bromine, <900ppm chlorine (<1500ppm total Br + Cl) and <1000ppm antimony compounds.
- I = Industrial
- E = Pb-free and Green
- X suffix = Tape/Reel
- For packaging detail, go to our website at: <https://www.diodes.com/assets/MediaList-Attachments/Diodes-Package-Information.pdf>

**IMPORTANT NOTICE**

1. DIODES INCORPORATED (Diodes) AND ITS SUBSIDIARIES MAKE NO WARRANTY OF ANY KIND, EXPRESS OR IMPLIED, WITH REGARDS TO ANY INFORMATION CONTAINED IN THIS DOCUMENT, INCLUDING, BUT NOT LIMITED TO, THE IMPLIED WARRANTIES OF MERCHANTABILITY, FITNESS FOR A PARTICULAR PURPOSE OR NON-INFRINGEMENT OF THIRD PARTY INTELLECTUAL PROPERTY RIGHTS (AND THEIR EQUIVALENTS UNDER THE LAWS OF ANY JURISDICTION).

2. The Information contained herein is for informational purpose only and is provided only to illustrate the operation of Diodes' products described herein and application examples. Diodes does not assume any liability arising out of the application or use of this document or any product described herein. This document is intended for skilled and technically trained engineering customers and users who design with Diodes' products. Diodes' products may be used to facilitate safety-related applications; however, in all instances customers and users are responsible for (a) selecting the appropriate Diodes products for their applications, (b) evaluating the suitability of Diodes' products for their intended applications, (c) ensuring their applications, which incorporate Diodes' products, comply the applicable legal and regulatory requirements as well as safety and functional-safety related standards, and (d) ensuring they design with appropriate safeguards (including testing, validation, quality control techniques, redundancy, malfunction prevention, and appropriate treatment for aging degradation) to minimize the risks associated with their applications.

3. Diodes assumes no liability for any application-related information, support, assistance or feedback that may be provided by Diodes from time to time. Any customer or user of this document or products described herein will assume all risks and liabilities associated with such use, and will hold Diodes and all companies whose products are represented herein or on Diodes' websites, harmless against all damages and liabilities.

4. Products described herein may be covered by one or more United States, international or foreign patents and pending patent applications. Product names and markings noted herein may also be covered by one or more United States, international or foreign trademarks and trademark applications. Diodes does not convey any license under any of its intellectual property rights or the rights of any third parties (including third parties whose products and services may be described in this document or on Diodes' website) under this document.

5. Diodes' products are provided subject to Diodes' Standard Terms and Conditions of Sale (<https://www.diodes.com/about/company/terms-and-conditions/terms-and-conditions-of-sales/>) or other applicable terms. This document does not alter or expand the applicable warranties provided by Diodes. Diodes does not warrant or accept any liability whatsoever in respect of any products purchased through unauthorized sales channel.

6. Diodes' products and technology may not be used for or incorporated into any products or systems whose manufacture, use or sale is prohibited under any applicable laws and regulations. Should customers or users use Diodes' products in contravention of any applicable laws or regulations, or for any unintended or unauthorized application, customers and users will (a) be solely responsible for any damages, losses or penalties arising in connection therewith or as a result thereof, and (b) indemnify and hold Diodes and its representatives and agents harmless against any and all claims, damages, expenses, and attorney fees arising out of, directly or indirectly, any claim relating to any noncompliance with the applicable laws and regulations, as well as any unintended or unauthorized application.

7. While efforts have been made to ensure the information contained in this document is accurate, complete and current, it may contain technical inaccuracies, omissions and typographical errors. Diodes does not warrant that information contained in this document is error-free and Diodes is under no obligation to update or otherwise correct this information. Notwithstanding the foregoing, Diodes reserves the right to make modifications, enhancements, improvements, corrections or other changes without further notice to this document and any product described herein. This document is written in English but may be translated into multiple languages for reference. Only the English version of this document is the final and determinative format released by Diodes.

8. Any unauthorized copying, modification, distribution, transmission, display or other use of this document (or any portion hereof) is prohibited. Diodes assumes no responsibility for any losses incurred by the customers or users or any third parties arising from any such unauthorized use.

9. This Notice may be periodically updated with the most recent version available at <https://www.diodes.com/about/company/terms-and-conditions/important-notice>

The Diodes logo is a registered trademark of Diodes Incorporated in the United States and other countries.

All other trademarks are the property of their respective owners.

© 2023 Diodes Incorporated. All Rights Reserved.

[www.diodes.com](http://www.diodes.com)

## Looking for pricing, stock, or lifecycle information?

Click below to explore more details on WIN SOURCE:

 [View PI6CB18200ZDIEX on WIN SOURCE](#)

 [Diodes Incorporated](#) Information

## Optimize Your Supply Chain with WIN SOURCE Solutions

-  Global Sourcing Solution
-  Obsolete Management
-  Cost Control Management
-  Shortage Management
-  Alternative Solution
-  Excess Inventory Management