



**THE DATASHEET OF
DS34LV86TM**



DS34LV86T 3V Enhanced CMOS Quad Differential Line Receiver

Check for Samples: [DS34LV86T](#)

FEATURES

- **Low Power CMOS Design (30 mW Typical)**
- **Interoperable With Existing 5V RS-422 Networks**
- **Industrial Temperature Range**
- **Meets TIA/EIA-422-B (RS-422) and ITU-T V.11 Recommendation**
- **3.3V Operation**
- **$\pm 7V$ Common Mode Range @ $V_{ID} = 3V$**
- **$\pm 10V$ Common Mode Range @ $V_{ID} = 0.2V$**
- **Receiver OPEN Input Failsafe Feature**
- **Ensured AC Parameter:**
 - **Maximum Receiver Skew: 4 ns**
 - **Transition Time: 10 ns**
- **Pin Compatible With DS34C86T**
- **32 MHz Toggle Frequency**
- **>6.5k ESD Tolerance (HBM)**
- **Available in SOIC Packaging**

DESCRIPTION

The DS34LV86T is a high speed quad differential CMOS receiver that meets the requirements of both TIA/EIA-422-B and ITU-T V.11. The CMOS DS34LV86T features typical low static I_{CC} of 9 mA which makes it ideal for battery powered and power conscious applications. The Tri-State enables, EN, allow the device to be disabled when not in use to minimize power consumption. The dual enable scheme allows for flexibility in turning receivers on and off.

The receiver output (RO) is ensured to be High when the inputs are left open. The receiver can detect signals as low as ± 200 mV over the common mode range of $\pm 10V$. The receiver outputs (RO) are compatible with TTL and LVCMOS levels.

Connection Diagram

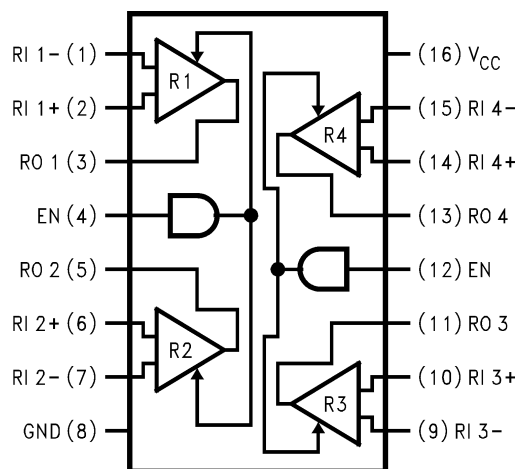

Figure 1. SOIC (Top View)
See Package Number D



Please be aware that an important notice concerning availability, standard warranty, and use in critical applications of Texas Instruments semiconductor products and disclaimers thereto appears at the end of this data sheet.

TRUTH TABLE⁽¹⁾

Enable EN	Inputs RI+–RI–	Output RO
L	X	Z
H	$V_{ID} \geq +0.2V$	H
H	$V_{ID} \leq -0.2V$	L
H	Open†	H

- (1) L = Logic Low
 H = Logic High
 X = Irrelevant
 Z = Tri-State
 † = Open, Not Terminated



These devices have limited built-in ESD protection. The leads should be shorted together or the device placed in conductive foam during storage or handling to prevent electrostatic damage to the MOS gates.

ABSOLUTE MAXIMUM RATINGS⁽¹⁾⁽²⁾

Supply Voltage (V_{CC})		+7V
Enable Input Voltage (EN)		+7V
Receiver Input Voltage	(V_{ID} : RI+, RI–)	$\pm 14V$
Receiver Input Voltage	(V_{CM} : RI+, RI–)	$\pm 14V$
Receiver Output Voltage (RO)		–0.5V to $V_{CC} + 0.5V$
Receiver Output Current (RO)		± 25 mA
Maximum Package Power Dissipation @ +25°C	D Package	1190 mW
Derate D Package		9.8 mW/°C above +25°C
Storage Temperature Range		–65°C to +150°C
Lead Temperature Range	Soldering (4 Seconds)	+260°C
ESD Ratings (HBM, 1.5k, 100 pF)	Receiver Inputs and Enables	≥ 6.5 kV
	Other Pins	≥ 2 kV

- (1) Absolute Maximum Ratings are those values beyond which the safety of the device cannot be ensured. They are not meant to imply that the devices should be operated at these limits. The table of [Electrical Characteristics](#) specifies conditions of device operation.
- (2) If Military/Aerospace specified devices are required, please contact the Texas Instruments Sales Office/ Distributors for availability and specifications.

RECOMMENDED OPERATING CONDITIONS

	Min	Typ	Max	Units	
Supply Voltage (V_{CC})	3.0	3.3	3.6	V	
Operating Free Air	Temperature (T_A)	–40	+25	+85	°C

ELECTRICAL CHARACTERISTICS⁽¹⁾⁽²⁾

Over Supply Voltage and Operating Temperature ranges, unless otherwise specified.

Symbol	Parameter	Conditions	Pin	Min	Typ	Max	Units
V_{TH}	Differential Input Threshold	$V_{OUT} = V_{OH}$ or V_{OL} $-7V < V_{CM} < +7V$	RI+, RI-	-200	±17.5	+200	mV
V_{HY}	Hysteresis	$V_{CM} = 1.5V$			35		mV
V_{IH}	Minimum High Level Input Voltage		EN	2.0			V
V_{IL}	Minimum Low Level Input Voltage					0.8	V
R_{IN}	Input Resistance	$V_{IN} = -7V, +7V$ (Other Input = GND)	RI+, RI-	5.0	8.5		kΩ
I_{IN}	Input Current (Other Input = 0V, Power On or $V_{CC} = 0V$)	$V_{IN} = +10V$		0	1.1	1.8	mA
		$V_{IN} = +3V$		0	0.27		mA
		$V_{IN} = 0.5V$			-0.02		mA
		$V_{IN} = -3V$		0	-0.43		mA
		$V_{IN} = -10V$		0	-1.26	-2.2	mA
I_{EN}		$V_{IN} = 0V$ to V_{CC}	EN			±1	μA
V_{OH}	High Level Output Voltage	$I_{OH} = -6$ mA, $V_{ID} = +1V$ $I_{OH} = -6$ mA, $V_{ID} = OPEN$	RO	2.4	3		V
V_{OH}	High Level Output Voltage	$I_{OH} = -100$ μA, $V_{ID} = +1V$ $I_{OH} = -100$ μA, $V_{ID} = OPEN$			$V_{CC} - 0.1$		V
V_{OL}	Low Level Output Voltage	$I_{OL} = +6$ mA, $V_{ID} = -1V$			0.13	0.5	V
I_{OZ}	Output Tri-State Leakage Current	$V_{IN} = V_{CC}$ or GND EN = V_{IL}				±50	μA
I_{SC}	Output Short Circuit Current	$V_O = 0V$, $V_{ID} \geq 200$ mV See ⁽³⁾			-10	-35	-70
I_{CC}	Power Supply Current	No Load, All RI+, RI- = Open, EN = V_{CC} or GND	V_{CC}		9	15	mA

- (1) Current into device pins is defined as positive. Current out of device pins is defined as negative. All voltages are referenced to ground except V_{ID} .
- (2) All typicals are given for: $V_{CC} = +3.3V$, $T_A = +25^\circ C$.
- (3) Short one output at a time to ground. Do not exceed package power dissipation ratings.

SWITCHING CHARACTERISTICS⁽¹⁾⁽²⁾⁽³⁾

Over Supply Voltage and Operating Temperature ranges, unless otherwise specified.

Symbol	Parameter	Conditions	Min	Typ	Max	Units
t_{PHL}	Propagation Delay High to Low	$C_L = 15\text{ pF}$ See (Figure 2 and Figure 3)	6	17.5	35	ns
t_{PLH}	Propagation Delay Low to High		6	17.8	35	ns
t_r	Rise Time (20% to 80%)		4.1	10	ns	
t_f	Fall Time (80% to 20%)		3.3	10	ns	
t_{PHZ}	Disable Time	$C_L = 50\text{ pF}$ See (Figure 4 and Figure 5)			40	ns
t_{PLZ}	Disable Time				40	ns
t_{PZH}	Enable Time				40	ns
t_{PZL}	Enable Time				40	ns
t_{SK1}	Skew, $ t_{PHL} - t_{PLH} $ See ⁽⁴⁾	$C_L = 15\text{ pF}$		0.3	4	ns
t_{SK2}	Skew, Pin to Pin See ⁽⁵⁾			0.6	4	ns
t_{SK3}	Skew, Part to Part See ⁽⁶⁾			7	17	ns
f_{MAX}	Maximum Operating Frequency See ⁽⁷⁾	$C_L = 15\text{ pF}$	32			MHz

- (1) All typicals are given for: $V_{CC} = +3.3\text{V}$, $T_A = +25^\circ\text{C}$.
- (2) Generator waveform for all tests unless otherwise specified: $f = 1\text{ MHz}$, Duty Cycle = 50%, $Z_O = 50\Omega$, $t_r \leq 10\text{ ns}$, $t_f \leq 10\text{ ns}$.
- (3) C_L includes probe and jig capacitance.
- (4) t_{SK1} is the $|t_{PHL} - t_{PLH}|$ of a channel.
- (5) t_{SK2} is the maximum skew between any two channels within a device, on either edge.
- (6) t_{SK3} is the difference in propagation delay times between any channels of any devices. This specification (maximum limit) applies to devices within $V_{CC} \pm 0.1\text{V}$ of one another, and a Delta $T_A = \pm 5^\circ\text{C}$ (between devices) within the operating temperature range. This parameter is specified by design and characterization.
- (7) All channels switching, output duty cycle criteria is 40%/60% measured at 50% Input = 1V to 2V, 50% Duty Cycle, $t_r/t_f \leq 5$. This parameter is ensured by design and characterization.

PARAMETER MEASUREMENT INFORMATION

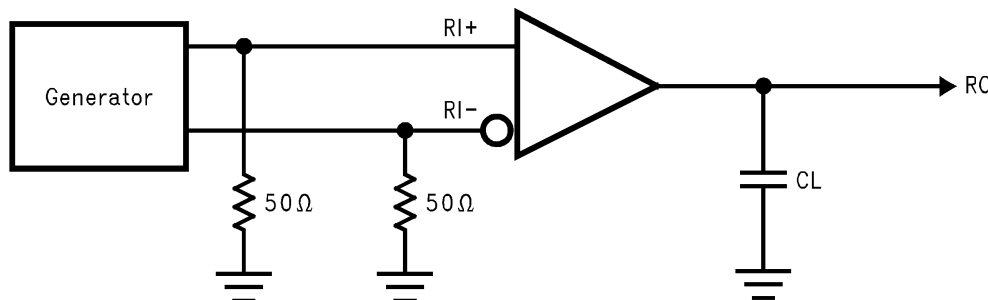

Generator waveform for all tests unless otherwise specified: $f = 1\text{ MHz}$, Duty Cycle = 50%, $Z_O = 50\Omega$, $t_r \leq 10\text{ ns}$, $t_f \leq 10\text{ ns}$.

C_L includes probe and jig capacitance.

Figure 2. Receiver Propagation Delay and Transition Time Test Circuit

PARAMETER MEASUREMENT INFORMATION (continued)

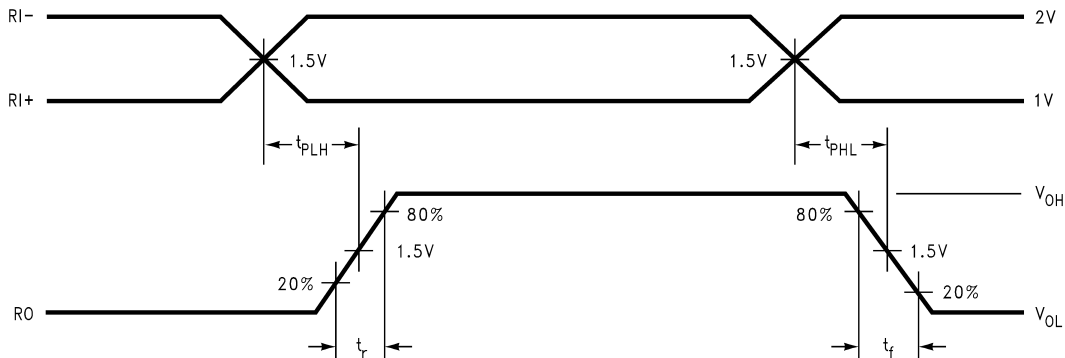

Generator waveform for all tests unless otherwise specified: $f = 1 \text{ MHz}$, Duty Cycle = 50%, $Z_O = 50\Omega$, $t_r \leq 10 \text{ ns}$, $t_f \leq 10 \text{ ns}$.

C_L includes probe and jig capacitance.

Figure 3. Receiver Propagation Delay and Transition Time Waveform

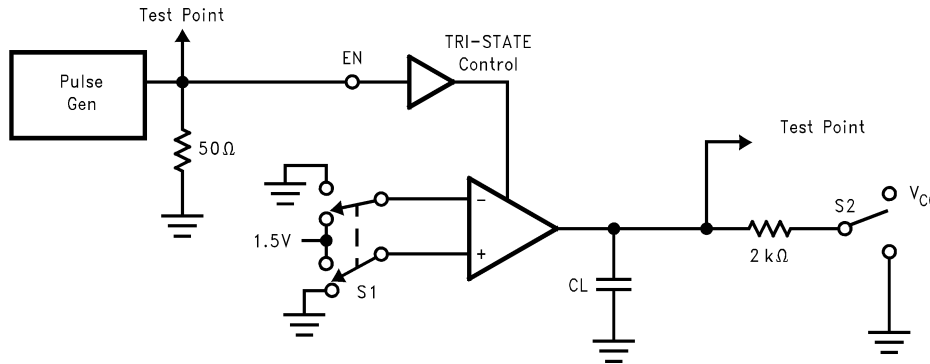
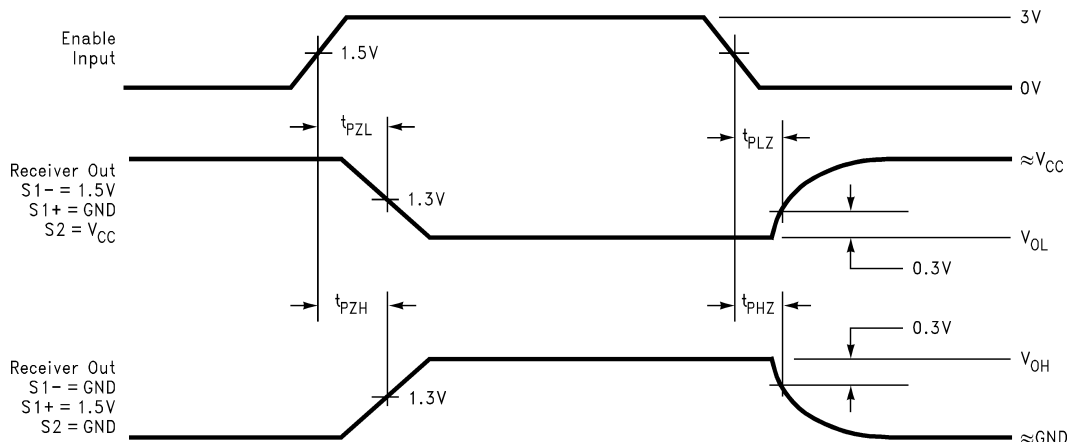

Figure 4. Receiver Tri-State Test Circuit



Generator waveform for all tests unless otherwise specified: $f = 1 \text{ MHz}$, Duty Cycle = 50%, $Z_O = 50\Omega$, $t_r \leq 10 \text{ ns}$, $t_f \leq 10 \text{ ns}$.

C_L includes probe and jig capacitance.

Figure 5. Receiver Tri-State Output Enable and Disable Waveforms

TYPICAL APPLICATION INFORMATION

General application guidelines and hints for differential drivers receivers may be found in the following application notes:

AN-214 (SNLA137), AN-457 (SNLA148), AN-805 (SNOA233), AN-847 (SNLA031), AN-903 (SNLA034), AN-912 (SNLA036), AN-916 (SNLA219)

Power Decoupling Recommendations: Bypass caps must be used on power pins. High frequency ceramic (surface mount is recommended) 0.1 μ F in parallel with 0.01 μ F at the power supply pin. A 10 μ F or greater solid tantalum or electrolytic should be connected at the power entry point on the printed circuit board.

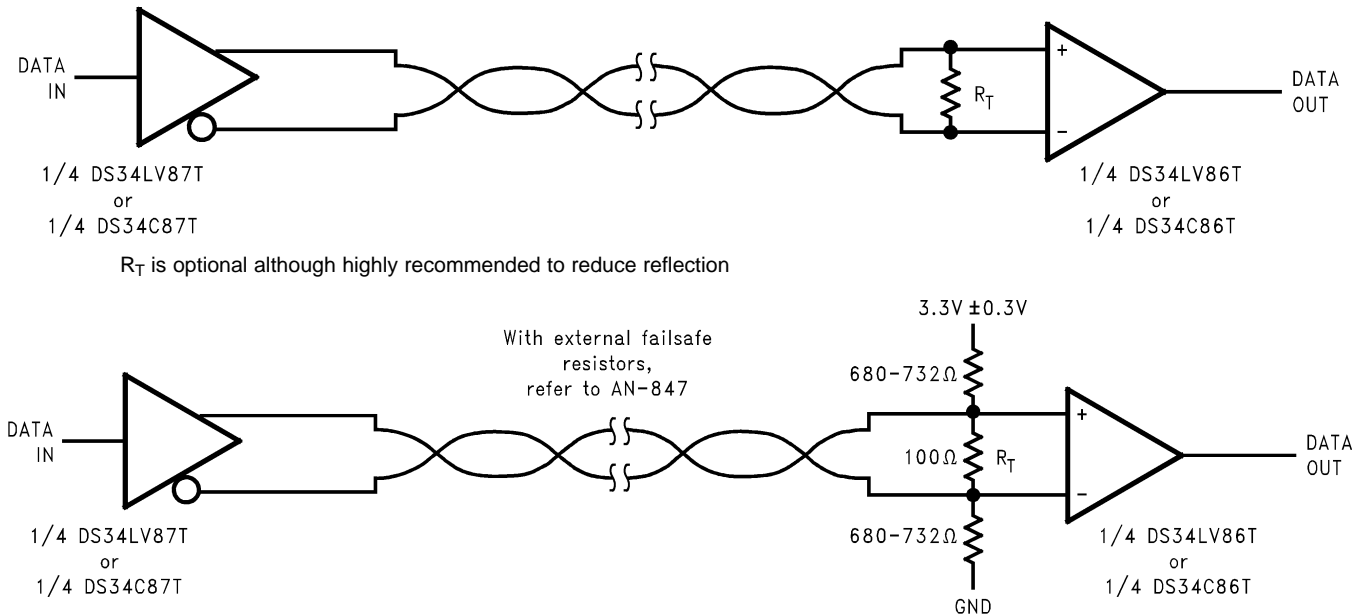

Figure 6. Typical Receiver Connections

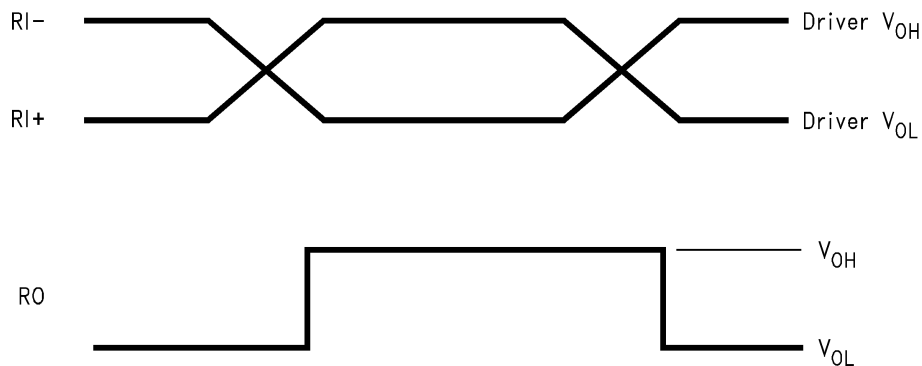

Figure 7. Typical Receiver Output Waveforms

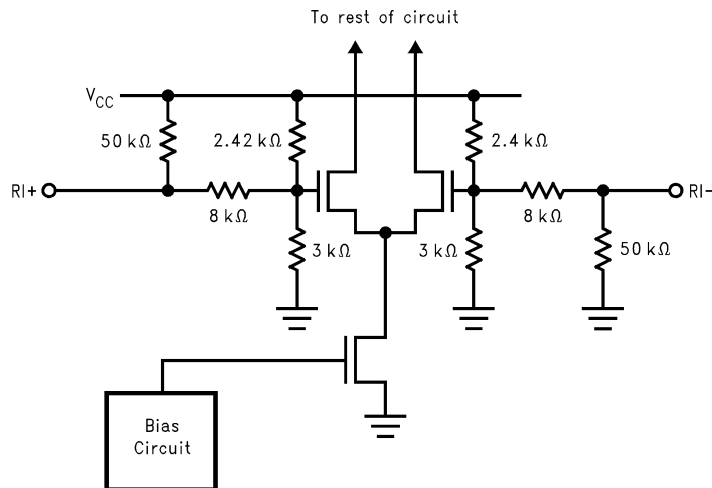

Figure 8. Typical Receiver Input Circuit

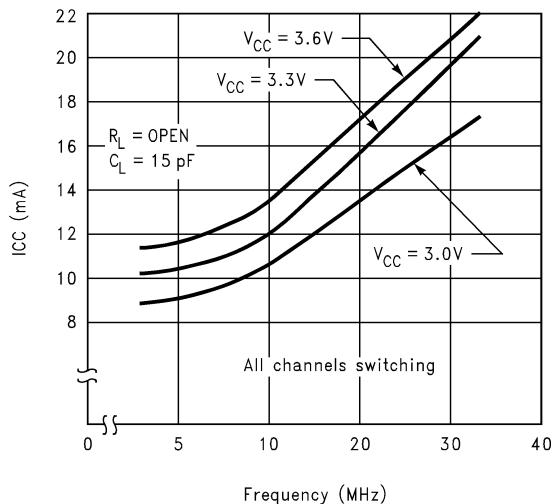

Figure 9. Typical ICC vs Frequency

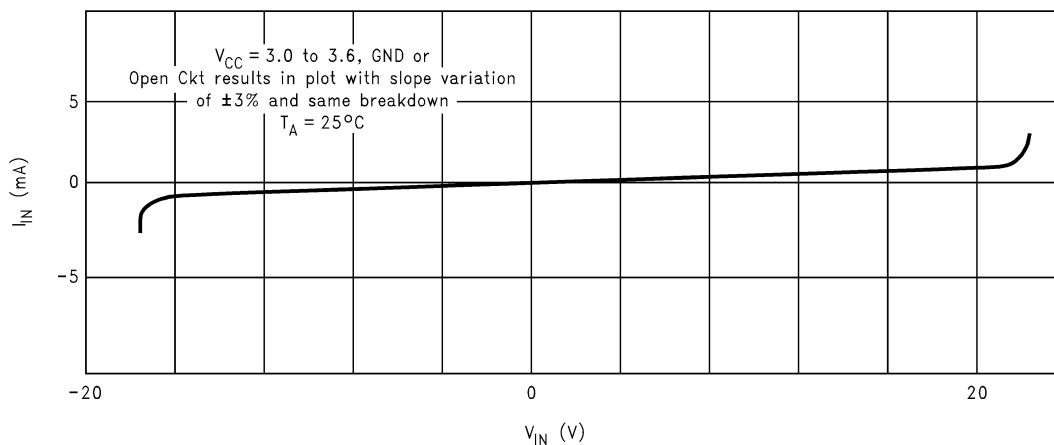

Figure 10. I_{IN} vs V_{IN} (Power On, Power Off)

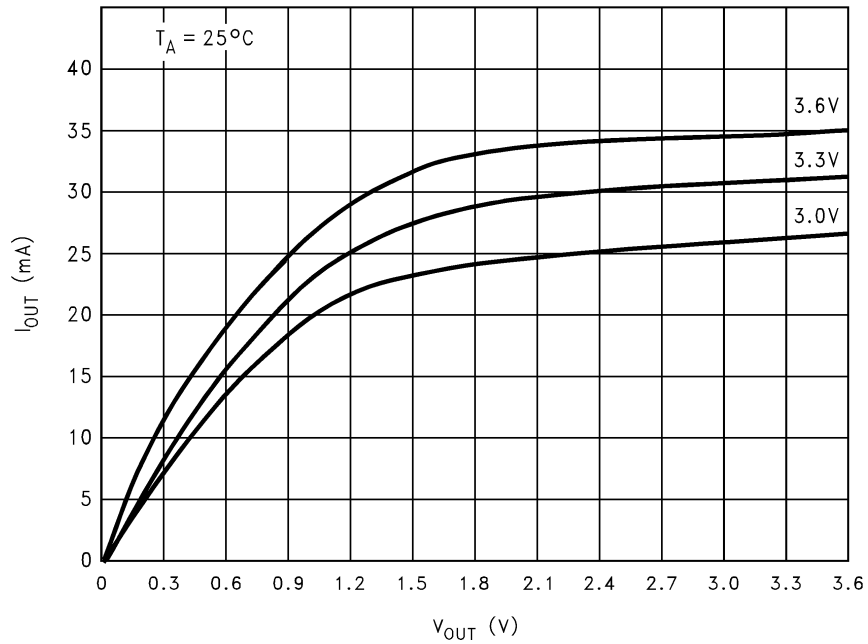

Figure 11. I_{OL} vs V_{OL}

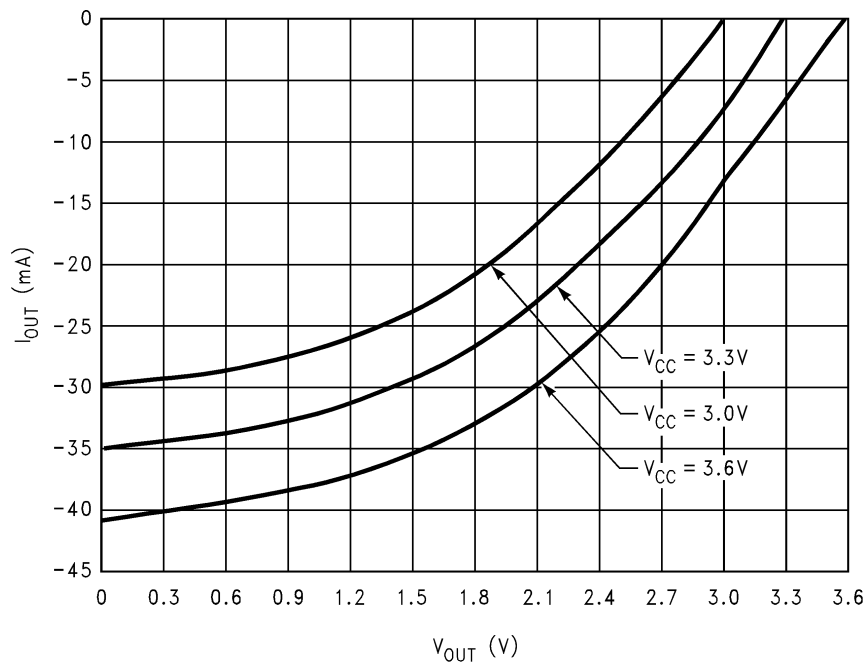

Figure 12. I_{OH} vs V_{OH}

REVISION HISTORY

Changes from Revision C (April 2013) to Revision D	Page
<hr/> <ul style="list-style-type: none">• Changed layout of National Data Sheet to TI format	<hr/> 8

PACKAGING INFORMATION

Orderable Device	Status (1)	Package Type	Package Drawing	Pins	Package Qty	Eco Plan (2)	Lead/Ball Finish (6)	MSL Peak Temp (3)	Op Temp (°C)	Device Marking (4/5)	Samples
DS34LV86TM/NOPB	ACTIVE	SOIC	D	16	48	Green (RoHS & no Sb/Br)	CU SN	Level-1-260C-UNLIM	-40 to 85	DS34LV86 TM	Samples
DS34LV86TMX/NOPB	ACTIVE	SOIC	D	16	2500	Green (RoHS & no Sb/Br)	CU SN	Level-1-260C-UNLIM	-40 to 85	DS34LV86 TM	Samples

(1) The marketing status values are defined as follows:

ACTIVE: Product device recommended for new designs.

LIFEBUY: TI has announced that the device will be discontinued, and a lifetime-buy period is in effect.

NRND: Not recommended for new designs. Device is in production to support existing customers, but TI does not recommend using this part in a new design.

PREVIEW: Device has been announced but is not in production. Samples may or may not be available.

OBsolete: TI has discontinued the production of the device.

(2) **RoHS:** TI defines "RoHS" to mean semiconductor products that are compliant with the current EU RoHS requirements for all 10 RoHS substances, including the requirement that RoHS substance do not exceed 0.1% by weight in homogeneous materials. Where designed to be soldered at high temperatures, "RoHS" products are suitable for use in specified lead-free processes. TI may reference these types of products as "Pb-Free".

RoHS Exempt: TI defines "RoHS Exempt" to mean products that contain lead but are compliant with EU RoHS pursuant to a specific EU RoHS exemption.

Green: TI defines "Green" to mean the content of Chlorine (Cl) and Bromine (Br) based flame retardants meet JS709B low halogen requirements of <=1000ppm threshold. Antimony trioxide based flame retardants must also meet the <=1000ppm threshold requirement.

(3) MSL, Peak Temp. - The Moisture Sensitivity Level rating according to the JEDEC industry standard classifications, and peak solder temperature.

(4) There may be additional marking, which relates to the logo, the lot trace code information, or the environmental category on the device.

(5) Multiple Device Markings will be inside parentheses. Only one Device Marking contained in parentheses and separated by a "~" will appear on a device. If a line is indented then it is a continuation of the previous line and the two combined represent the entire Device Marking for that device.

(6) Lead/Ball Finish - Orderable Devices may have multiple material finish options. Finish options are separated by a vertical ruled line. Lead/Ball Finish values may wrap to two lines if the finish value exceeds the maximum column width.

Important Information and Disclaimer:The information provided on this page represents TI's knowledge and belief as of the date that it is provided. TI bases its knowledge and belief on information provided by third parties, and makes no representation or warranty as to the accuracy of such information. Efforts are underway to better integrate information from third parties. TI has taken and continues to take reasonable steps to provide representative and accurate information but may not have conducted destructive testing or chemical analysis on incoming materials and chemicals. TI and TI suppliers consider certain information to be proprietary, and thus CAS numbers and other limited information may not be available for release.

In no event shall TI's liability arising out of such information exceed the total purchase price of the TI part(s) at issue in this document sold by TI to Customer on an annual basis.

TAPE AND REEL INFORMATION

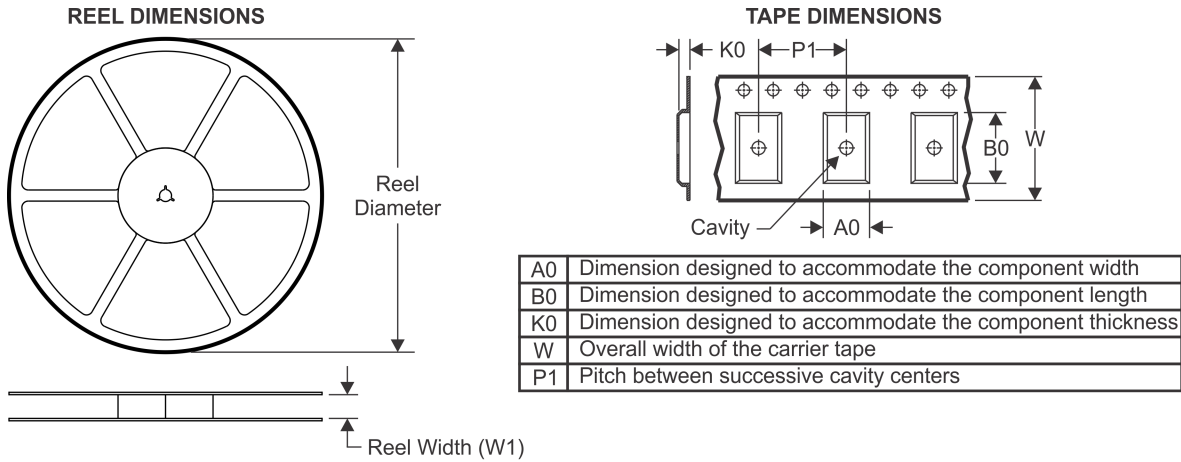

QUADRANT ASSIGNMENTS FOR PIN 1 ORIENTATION IN TAPE



*All dimensions are nominal

Device	Package Type	Package Drawing	Pins	SPQ	Reel Diameter (mm)	Reel Width W1 (mm)	A0 (mm)	B0 (mm)	K0 (mm)	P1 (mm)	W (mm)	Pin1 Quadrant
DS34LV86TMX/NOPB	SOIC	D	16	2500	330.0	16.4	6.5	10.3	2.3	8.0	16.0	Q1

TAPE AND REEL BOX DIMENSIONS



*All dimensions are nominal

Device	Package Type	Package Drawing	Pins	SPQ	Length (mm)	Width (mm)	Height (mm)
DS34LV86TMX/NOPB	SOIC	D	16	2500	367.0	367.0	35.0

D (R-PDSO-G16)

PLASTIC SMALL OUTLINE



4040047-6/M 06/11

- NOTES:
- A. All linear dimensions are in inches (millimeters).
 - B. This drawing is subject to change without notice.
 -  C. Body length does not include mold flash, protrusions, or gate burrs. Mold flash, protrusions, or gate burrs shall not exceed 0.006 (0,15) each side.
 -  D. Body width does not include interlead flash. Interlead flash shall not exceed 0.017 (0,43) each side.
 - E. Reference JEDEC MS-012 variation AC.

IMPORTANT NOTICE AND DISCLAIMER

TI PROVIDES TECHNICAL AND RELIABILITY DATA (INCLUDING DATASHEETS), DESIGN RESOURCES (INCLUDING REFERENCE DESIGNS), APPLICATION OR OTHER DESIGN ADVICE, WEB TOOLS, SAFETY INFORMATION, AND OTHER RESOURCES "AS IS" AND WITH ALL FAULTS, AND DISCLAIMS ALL WARRANTIES, EXPRESS AND IMPLIED, INCLUDING WITHOUT LIMITATION ANY IMPLIED WARRANTIES OF MERCHANTABILITY, FITNESS FOR A PARTICULAR PURPOSE OR NON-INFRINGEMENT OF THIRD PARTY INTELLECTUAL PROPERTY RIGHTS.

These resources are intended for skilled developers designing with TI products. You are solely responsible for (1) selecting the appropriate TI products for your application, (2) designing, validating and testing your application, and (3) ensuring your application meets applicable standards, and any other safety, security, or other requirements. These resources are subject to change without notice. TI grants you permission to use these resources only for development of an application that uses the TI products described in the resource. Other reproduction and display of these resources is prohibited. No license is granted to any other TI intellectual property right or to any third party intellectual property right. TI disclaims responsibility for, and you will fully indemnify TI and its representatives against, any claims, damages, costs, losses, and liabilities arising out of your use of these resources.

TI's products are provided subject to TI's Terms of Sale (www.ti.com/legal/termsofsale.html) or other applicable terms available either on ti.com or provided in conjunction with such TI products. TI's provision of these resources does not expand or otherwise alter TI's applicable warranties or warranty disclaimers for TI products.

Mailing Address: Texas Instruments, Post Office Box 655303, Dallas, Texas 75265
Copyright © 2019, Texas Instruments Incorporated

Looking for pricing, stock, or lifecycle information?

Click below to explore more details on WIN SOURCE:

 [View DS34LV86TM](#) on WIN SOURCE

 [Texas Instruments](#) Information

Optimize Your Supply Chain with WIN SOURCE Solutions

-  Global Sourcing Solution
-  Obsolete Management
-  Cost Control Management
-  Shortage Management
-  Alternative Solution
-  Excess Inventory Management