

Surface Mount Type TQC series B size



POSCAP

Features

- High voltage (35 V.DC max.)
- RoHS compliance, Halogen free

Specifications

Size code	B2	
Category temp. range	-55 °C to +105 °C	
Rated volt. range	16 V.DC to 35 V.DC	
Category volt. range	16 V.DC to 35 V.DC	
Rated cap. range	3.9 μF to 33 μF	
Capacitance tolerance	±20 % (120 Hz / +20 °C)	
Leakage current	Please see the attached characteristics list	
Dissipation factor(tan δ)	Please see the attached characteristics list	
Surge voltage (V.DC)	Rated voltage × 1.15	
Endurance	+105 °C 2000 h (16TQC33MYFB : 1000 h), rated voltage applied	
	Capacitance change	Within ±20 % of the initial value
	Dissipation factor(tan δ)	≤ 1.5 times of the initial limit
	Leakage current	Within the initial limit
Damp heat (Steady State)	+60 °C, 90 % to 95 %, 500 h, No-applied voltage	
	Capacitance change	Within +40 %, -20 % of the initial value
	Dissipation factor(tan δ)	≤ 1.5 times of the initial limit
	Leakage current	≤ 3 times of the initial limit

Marking

Rated voltage code

C	16	E	25
D	20	V	35

Unit : V.DC

R. capacitance code

L6	2.7	Y6	8.2	J7	22
Q6	3.9	A7	10	N7	33
U6	5.6	E7	15		

Unit : μF

Dimensions (not to scale)

Size code	L±0.2	W±0.2	H±0.1	S±0.2	W1±0.1
B2	3.5	2.8	1.9	0.8	2.2

Unit : mm

* Externals of figure are the reference.

Characteristics list

Rated volt. (V.DC)	Rated temp. (°C)	Category volt. (V.DC)	Category temp. (°C)	Rated cap. (μF)	Case size (mm)			Size code	Specifications				Standard		Floor life level	
					L	W	H		Ripple current ^{*1} (mA r.m.s.)	ESR ^{*2} (mΩ max.)	tan δ ^{*3}	LC ^{*4} (μA)	Part number	Min. packaging q'ty (pcs)	Reflow temp ≤260°C	Reflow temp ≤250°C
16	105	16	105	10	3.5	2.8	1.9	B2	800	100	0.10	48.0	16TQC10M	2000	-	3
	105	16	105	15	3.5	2.8	1.9		1000	90	0.10	72.0	16TQC15M	2000		
	105	16	105	22	3.5	2.8	1.9		1000	90	0.10	35.2	16TQC22MYFB	2000		
	105	16	105	33	3.5	2.8	1.9		1000	90	0.10	158.4	16TQC33MYFB	2000		
20	105	20	105	8.2	3.5	2.8	1.9		800	100	0.10	49.2	20TQC8R2M	2000		
	105	20	105	22	3.5	2.8	1.9		1100	90	0.10	132.0	20TQC22MYFB	2000		
25	105	25	105	5.6	3.5	2.8	1.9		800	100	0.10	42.0	25TQC5R6M	2000		
	105	25	105	15	3.5	2.8	1.9		900	100	0.10	112.5	25TQC15MYFB	2000		
35	105	35	105	3.9	3.5	2.8	1.9		500	400	0.10	40.9	35TQC3R9MYF	2000		

*1: Ripple current (100 kHz / +105 °C) *2: ESR (100 kHz / +20 °C) *3: tan δ (120 Hz / +20 °C) *4: After 5 minutes

◆ Please refer to each page in this catalog for "Reflow conditions", "Taping specifications" and "Floor life level".

◆ Small order quantity (500 pcs/reel) is available with TQC series. Please contact our sales representative if you prefer it.

Surface Mount Type TQC series D size



POSCAP

Features

- High voltage (35 V.DC max.)
- RoHS compliance, Halogen free

Specifications

Size code	D12	D15	D2	D3L
Category temp. range	-55 °C to +105 °C			
Rated volt. range	16 V.DC	16 V.DC to 25 V.DC	16 V.DC to 35 V.DC	16 V.DC to 25 V.DC
Category volt. range	16 V.DC	16 V.DC to 25 V.DC	16 V.DC to 35 V.DC	16 V.DC to 25 V.DC
Rated cap. range	33 µF	22 µF to 47 µF	10 µF to 150 µF	68 µF to 150 µF
Capacitance tolerance	±20 % (120 Hz / +20 °C)			
Leakage current	Please see the attached characteristics list			
Dissipation factor(tan δ)	Please see the attached characteristics list			
Surge voltage (V.DC)	Rated voltage × 1.15			
Endurance	+105 °C 1000 h rated voltage applied			
	Capacitance change	Within ±20 % of the initial value		
	Dissipation factor(tan δ)	≤ 1.5 times of the initial limit		
	Leakage current	Within the initial limit		
Damp heat (Steady State)	+60 °C, 90 % to 95 %, 500 h, No-applied voltage			
	Capacitance change	Within +40 %, -20 % of the initial value		
	Dissipation factor(tan δ)	≤ 1.5 times of the initial limit		
	Leakage current	≤ 3 times of the initial limit		

Marking

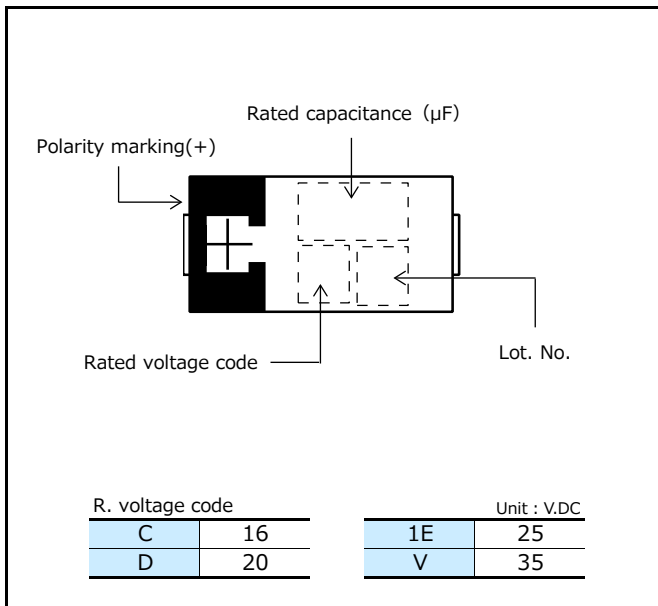

Dimensions (not to scale)

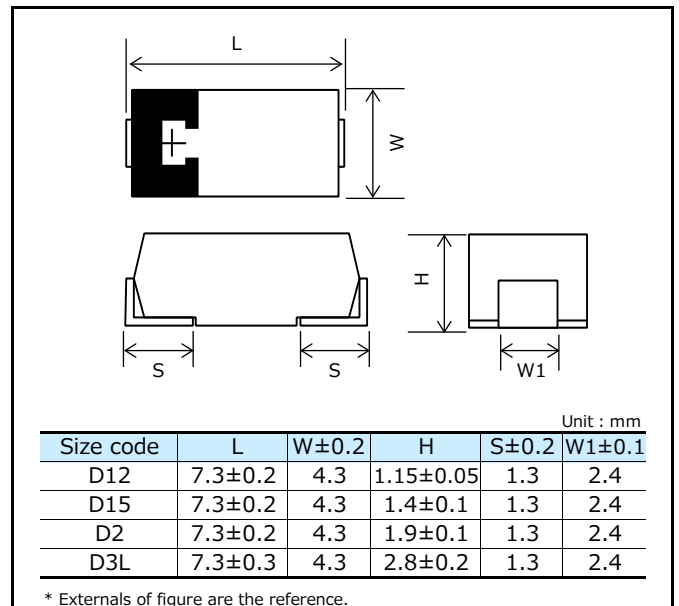

Characteristics list

Rated volt. (V.DC)	Rated temp. (°C)	Category volt. (V.DC)	Category temp. (°C)	Rated cap. (µF)	Case size (mm)			Size code	Specifications				Standard		Floor life level	
					L	W	H		Ripple current ^{*1} (mA r.m.s.)	ESR ^{*2} (mΩ max.)	tan δ ^{*3}	LC ^{*4} (µA)	Part number	Min. packaging q'ty (pcs)	Reflow temp ≤260°C	Reflow temp ≤250°C
16	105	16	105	33	7.3	4.3	##	D12	1800	40	0.10	52.8	16TQC33MYFS	4500	-	3
	105	16	105		7.3	4.3	1.9	D2	1400	70	0.10	52.8	16TQC33MYFD	3000		
	105	16	105	47	7.3	4.3	1.4	D15	1500	55	0.10	75.2	16TQC47MYFT	3000		
	105	16	105		7.3	4.3	1.9	D2	1800	40	0.10	75.2	16TQC47MW	3000		
	105	16	105		7.3	4.3	1.9		1450	55	0.10	75.2	16TQC47MYFD	3000		
	105	16	105	68	7.3	4.3	1.9	D2	1500	50	0.10	108.8	16TQC68MYF	3000		
	105	16	105	100	7.3	4.3	1.9		1800	50	0.10	160.0	16TQC100MYF	3000		
	105	16	105	150	7.3	4.3	2.8	D3L	1800	50	0.10	240.0	16TQC150MYF	2500		
	105	16	105	150	7.3	4.3	1.9	D2	1500	70	0.15	240.0	1CTQC15173F1	3000		
105	16	105	150	7.3	4.3	1.9	1500		70	0.15	240.0	1CTQC15173F1	3000			
20	105	20	105	33	7.3	4.3	1.9	D2	1400	60	0.10	66.0	20TQC33MYFD	3000		
	105	20	105	47	7.3	4.3	1.9		1450	55	0.10	94.0	20TQC47MYF	3000		
	105	20	105		100	7.3	4.3	1.4	D15	1500	55	0.10	94.0	20TQC47MYFT	3000	
	105	20	105	7.3		4.3	1.9	D2	1250	100	0.15	200.0	20TQC100MD2	3000		
	105	20	105	7.3		4.3	2.8	D3L	1700	55	0.10	200.0	20TQC100MYF	2500		
25	105	25	105	15	7.3	4.3	1.9	D2	1500	45	0.10	38.0	25TQC15MV	3000		
	105	25	105		7.3	4.3	1.9		1000	90	0.10	38.0	25TQC15MYFD	3000		
	105	25	105	22	7.3	4.3	1.9		1500	45	0.10	55.0	25TQC22MV	3000		
	105	25	105		7.3	4.3	1.9	1400	60	0.10	55.0	25TQC22MYFD	3000			
	105	25	105		7.3	4.3	1.4	D15	1400	70	0.10	55.0	25TQC22MYFT	3000		
	105	25	105	33	7.3	4.3	1.9	D2	1400	60	0.10	82.5	25TQC33MYF	3000		
	105	25	105	68	7.3	4.3	2.8	D3L	1400	70	0.10	170.0	25TQC68MYF	2500		
35	105	35	105	10	7.3	4.3	1.9	D2	1000	120	0.10	35.0	35TQC10M	3000		
	105	35	105		7.3	4.3	1.9		1000	120	0.10	35.0	35TQC10MYF	3000		
	105	35	105	15	7.3	4.3	1.9		900	150	0.10	52.5	35TQC15MYF	3000		

*1: Ripple current (100 kHz / +105 °C)

*2: ESR (100 kHz / +20 °C)

*3: tan δ (120 Hz / +20 °C)

*4: After 5 minutes

◆ Please refer to each page in this catalog for "Reflow conditions", "Taping specifications" and "Floor life level".

◆ Small order quantity (500 pcs/reel) is available with TQC series. Please contact our sales representative if you prefer it.

Guidelines and precautions regarding the technical information and use of our products described in this online catalog.

- If you want to use our products described in this online catalog for applications requiring special qualities or reliability, or for applications where the failure or malfunction of the products may directly jeopardize human life or potentially cause personal injury (e.g. aircraft and aerospace equipment, traffic and transportation equipment, combustion equipment, medical equipment, accident prevention, anti-crime equipment, and/or safety equipment), it is necessary to verify whether the specifications of our products fit to such applications. Please ensure that you will ask and check with our inquiry desk as to whether the specifications of our products fit to such applications use before you use our products.
- The quality and performance of our products as described in this online catalog only apply to our products when used in isolation. Therefore, please ensure you evaluate and verify our products under the specific circumstances in which our products are assembled in your own products and in which our products will actually be used.
- If you use our products in equipment that requires a high degree of reliability, regardless of the application, it is recommended that you set up protection circuits and redundancy circuits in order to ensure safety of your equipment.
- The products and product specifications described in this online catalog are subject to change for improvement without prior notice. Therefore, please be sure to request and confirm the latest product specifications which explain the specifications of our products in detail, before you finalize the design of your applications, purchase, or use our products.
- The technical information in this online catalog provides examples of our products' typical operations and application circuits. We do not guarantee the non-infringement of third party's intellectual property rights and we do not grant any license, right, or interest in our intellectual property.
- If any of our products, product specifications and/or technical information in this online catalog is to be exported or provided to non-residents, the laws and regulations of the exporting country, especially with regard to security and export control, shall be observed.

<Regarding the Certificate of Compliance with the EU RoHS Directive/REACH Regulations>

- The switchover date for compliance with the RoHS Directive/REACH Regulations varies depending on the part number or series of our products.
- When you use the inventory of our products for which it is unclear whether those products are compliant with the RoHS Directive/REACH Regulation, please select "Sales Inquiry" in the website inquiry form and contact us.

We do not take any responsibility for the use of our products outside the scope of the specifications, descriptions, guidelines and precautions described in this online catalog.

Looking for pricing, stock, or lifecycle information?

Click below to explore more details on WIN SOURCE:

 [View 16TQC150MYF on WIN SOURCE](#)

 [Panasonic](#) Information

Optimize Your Supply Chain with WIN SOURCE Solutions

-  Global Sourcing Solution
-  Obsolete Management
-  Cost Control Management
-  Shortage Management
-  Alternative Solution
-  Excess Inventory Management