



**THE DATASHEET OF  
MA46477-134**



# GaAs Hyperabrupt Varactor Diode

## Gamma = 1.0, 1.25, & 1.5



MA464xx Series  
Rev. V10

### Features

- Constant Gamma = 1.0, 1.25 & 1.5
- High Q (up to 4000 @ -4 Volts)
- More Linear Frequency Tuning
- High and Nearly Constant Modulation Sensitivity
- Lead-Free (RoHS Compliant) equivalents available with 260°C reflow compatibility

### Applications

- ISM

### Description

This series of tuning varactors are hyperabrupt junction Gallium Arsenide diodes featuring constant gamma 1.0 (MA4645x, MA4646x series), 1.25 (MA4647x, MA4648x series), & 1.5 (MA4641x, MA4642x series). These diodes offer high Q (up to 4000) permitting excellent tuning performance from VHF through Ka band. Each part in this series exhibits the large change in capacitance versus bias voltage characteristic of hyperabrupt junctions. The standard capacitance tolerance is  $\pm 10\%$ , with tighter tolerances available. Capacitance matching at one or more bias voltages is also available. All diode types are available in a wide selection of ceramic packages and in chip form. The constant gamma value of 1.0, 1.25 & 1.5 available with these diodes enables the circuit designer to produce significant improvements in circuit performance. Constant gamma tuning varactors permit more linear VCO frequency tuning than do conventional hyperabrupt tuning varactors. These varactors are particularly well suited for use in voltage tuned filters, analog phase shifters, and modulator circuits.

### Packaged Tuning Varactor Equivalent Circuit

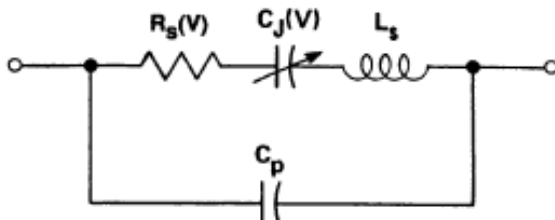

### Case Styles

(Dimensions are available upon request)

### Typical Coaxial Packages

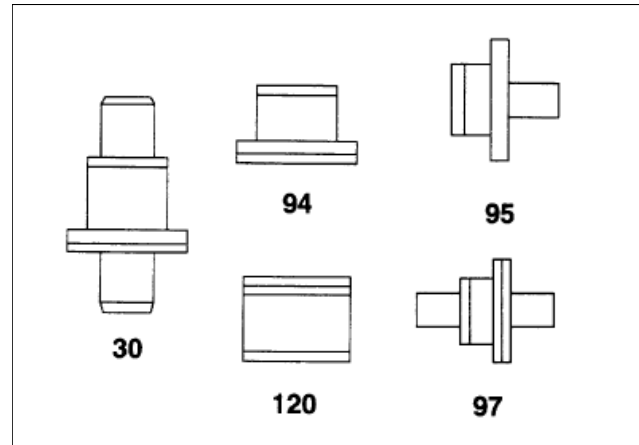

### Typical Coplanar Packages

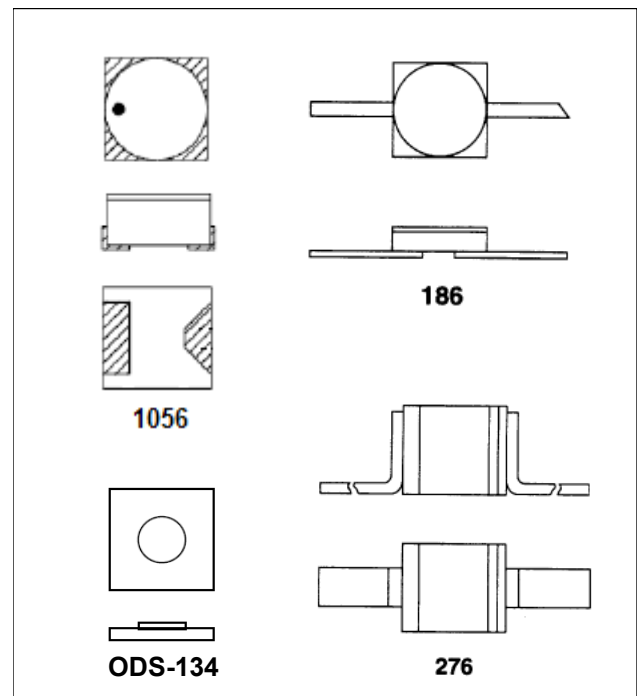

# GaAs Hyperabrupt Varactor Diode

## Gamma = 1.0, 1.25, & 1.5



MA464xx Series

Rev. V10

### Electrical Specifications<sup>1</sup>: T<sub>A</sub> = +25°C

#### Gamma = 1.0<sup>2</sup> MA46461

Gamma = 0.9 - 1.1, V<sub>R</sub> = 2 - 20 Volts  
 Junction Capacitance Ratio (C<sub>J2</sub>/C<sub>J20</sub>) = 5.0 - 8.0  
 Breakdown Voltage @ I<sub>R</sub> = 10 μA, V<sub>b</sub> = 22 V min.  
 Reverse Leakage Current @ V<sub>R</sub> = 18 V, I<sub>R</sub> = 100 nA max.

Part Number	Total Capacitance +/-10% <sup>3,4,5</sup>	Total Capacitance Ratio <sup>6</sup>	Q Minimum
	V <sub>R</sub> = 4 V f = 1 MHz	V <sub>R</sub> = 2 V / 20 V	V <sub>R</sub> = 4 V f = 50 MHz
	(pF)	-	-
MA46461	4.7	4.8-7.2	1500

#### Gamma = 1.25<sup>2</sup> MA4647x, MA4648x Series

Gamma = 1.13 - 1.38, V<sub>R</sub> = 2 - 20 Volts  
 Junction Capacitance Ratio (C<sub>J2</sub>/C<sub>J20</sub>) = 8.15 - 12.99  
 Breakdown Voltage @ I<sub>R</sub> = 10 μA, V<sub>b</sub> = 22 V min.  
 Reverse Leakage Current @ V<sub>R</sub> = 18 V, I<sub>R</sub> = 100 nA max.

Part Number	Total Capacitance +/-10% <sup>3,4,5</sup>	Total Capacitance Ratio <sup>5</sup>	Q Minimum
	V <sub>R</sub> = 4 V f = 1 MHz	V <sub>R</sub> = 2 V / 20 V	V <sub>R</sub> = 4 V f = 50 MHz
	(pF)	-	-
MA46470 <sup>7</sup>	0.5	2.2 - 4.1	4000
MA46471	0.7	3.6 - 5.6	4000
MA46472	1.0	4.8 - 7.4	3000
MA46473	1.2	4.8 - 7.4	3000
MA46474	1.5	5.0 - 7.4	3000
MA46477	2.2	6.6 - 8.7	3000
MA46479 <sup>6</sup>	3.3	6.4 - 10.0	2000
MA46480	3.7	6.8 - 11.0	2000
MA46481	4.7	6.9 - 11.1	1500
MA46483	6.8	7.2 - 11.5	1500
MA46485	10.0	7.5 - 12.0	1500

#### Gamma = 1.5<sup>2</sup> MA46413, MA46416, & MA46425

Gamma = 1.4 - 1.6 VR = 2 - 12 Volts  
 Junction Capacitance Ratio (C<sub>J2</sub>/C<sub>J12</sub>) = 6.2 - 10.8  
 Breakdown Voltage @ I<sub>R</sub> = 10 μA, V<sub>b</sub> = 18 V min.  
 Reverse Leakage Current @ V<sub>R</sub> = 10 V, I<sub>R</sub> = 100 nA max.

Part Number	Total Capacitance +/-10% <sup>3,4,5</sup>	Total Capacitance Ratio <sup>5</sup>	Q Minimum
	V <sub>R</sub> = 4 V f = 1 MHz	V <sub>R</sub> = 2 V / 12 V	V <sub>R</sub> = 4 V f = 50 MHz
	(pF)	-	-
MA46413	0.90 - 1.10	4.2 - 5.7	2500
MA46416	1.62 - 1.98	5.2 - 4.9	2500
MA46425	9.00 - 11.00	6.6 - 8.8	1200

- Not all GaAs tuning varactors are available in chip form. Please contact factory for part number information.
- The values guaranteed for gamma are measured on unpackaged chips. The total capacitance versus bias voltage curve will deviate slightly from the chip capacitance versus bias voltage curve due to the package parasitic capacitance (C<sub>p</sub>).
- Case parasitics (C<sub>p</sub> and L<sub>s</sub>) are given for most case styles along with case outlines in the appendix.
- Reverse voltage (V<sub>br</sub>) is measured at 10 microamps.
- The total capacitance and capacitance ratios shown are for diodes housed in case style 30 with C<sub>p</sub> = 0.170 pF unless otherwise specified. Other case styles will result in different values.
- This part is offered in die form only, shipped in a gel pack. The part number is MAVR-046479-01340G.
- For part number MA46470, the Junction Capacitance Ratio (C<sub>J2</sub>/C<sub>J20</sub>) = 8.0 Min

### Absolute Maximum Ratings<sup>8</sup>: T<sub>A</sub> = +25°C (Unless Otherwise Noted)

Parameter	Absolute Maximum
Reverse Voltage	Breakdown Voltage
Operating Temperature	-65°C to +175°C
Storage Temperature	65°C to +200°C

8. Operation of this device above any one of these parameters may cause permanent damage. The maximum storage and operating temperature of the plastic ODS-1088 case style is 125°C.

### Environmental Ratings per MIL-STD-750

Parameter	Method	Level
Storage Temperature	1031	See Absolute Maximum Ratings
Temperature Cycle	1051	10 cycles, -65°C to +175°C
Shock	2016	500 g's
Vibration	2056	15 g's

### Typical Performance Curves

**Junction Capacitance vs. Tuning Voltage**

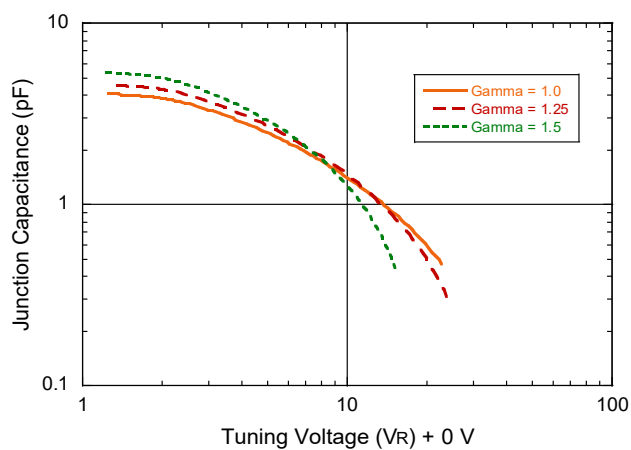

**Gamma vs. Reverse Bias Voltage**

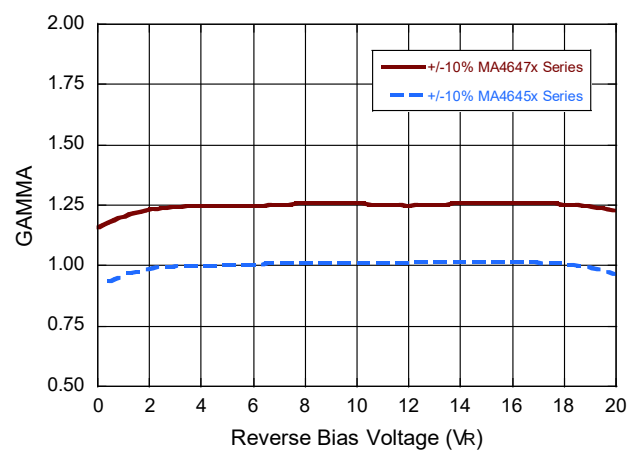

# GaAs Hyperabrupt Varactor Diode

## Gamma = 1.0, 1.25, & 1.5



**MA464xx Series**  
Rev. V10

### Typical Performance Curves

**Gamma = 1.0**

**Total Capacitance vs. Reverse Bias Voltage (ODS-30)**

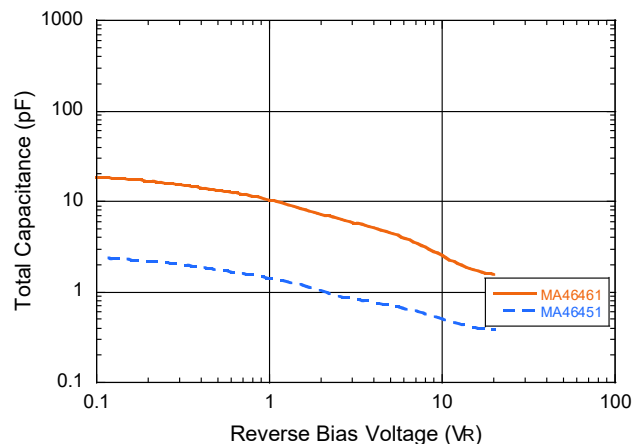

**Gamma = 1.25**

**Total Capacitance vs. Reverse Bias Voltage (ODS-30)**

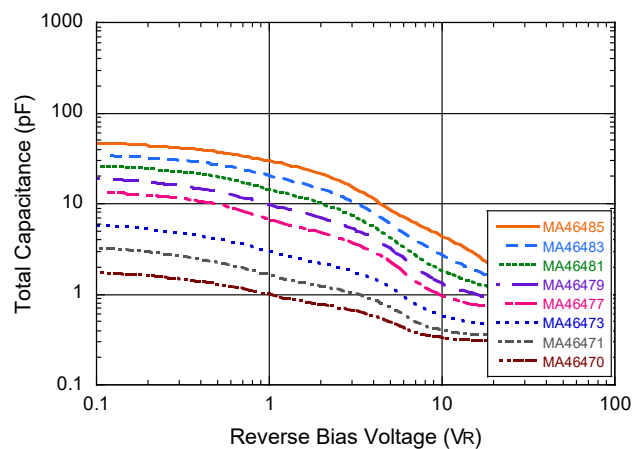

**Gamma = 1.25**

**Junction Capacitance vs. Reverse Bias Voltage (DIE)**

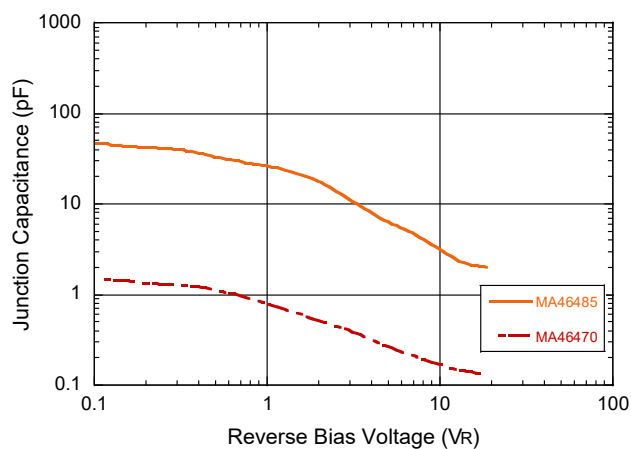

**Gamma = 1.5**

**Total Capacitance vs. Reverse Bias Voltage (ODS-30)**

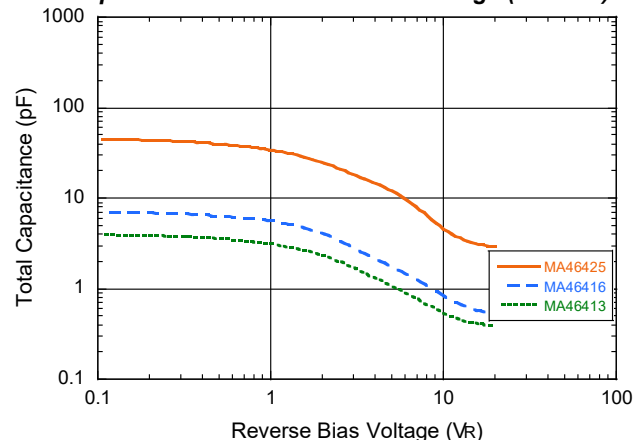

**Gamma = 1.5**

**Junction Capacitance vs. Reverse Bias Voltage (DIE)**

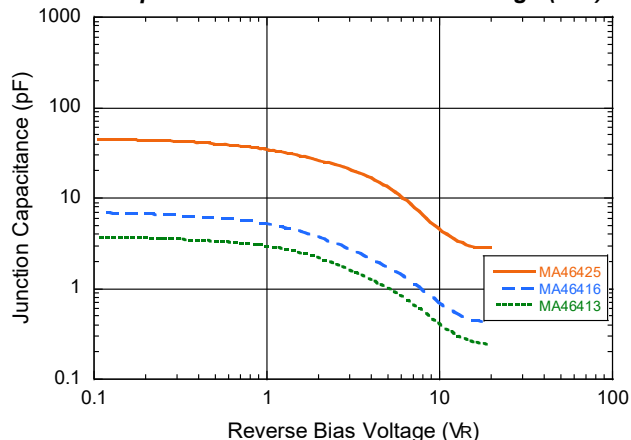

# GaAs Hyperabrupt Varactor Diode

## Gamma = 1.0, 1.25, & 1.5



**MA464xx Series**  
Rev. V10

MACOM Technology Solutions Inc. ("MACOM"). All rights reserved.

These materials are provided in connection with MACOM's products as a service to its customers and may be used for informational purposes only. Except as provided in its Terms and Conditions of Sale or any separate agreement, MACOM assumes no liability or responsibility whatsoever, including for (i) errors or omissions in these materials; (ii) failure to update these materials; or (iii) conflicts or incompatibilities arising from future changes to specifications and product descriptions, which MACOM may make at any time, without notice. These materials grant no license, express or implied, to any intellectual property rights.

THESE MATERIALS ARE PROVIDED "AS IS" WITH NO WARRANTY OR LIABILITY, EXPRESS OR IMPLIED, RELATING TO SALE AND/OR USE OF MACOM PRODUCTS INCLUDING FITNESS FOR A PARTICULAR PURPOSE, MERCHANTABILITY, INFRINGEMENT OF INTELLECTUAL PROPERTY RIGHT, ACCURACY OR COMPLETENESS, OR SPECIAL, INDIRECT, INCIDENTAL, OR CONSEQUENTIAL DAMAGES WHICH MAY RESULT FROM USE OF THESE MATERIALS.

MACOM products are not intended for use in medical, lifesaving or life sustaining applications. MACOM customers using or selling MACOM products for use in such applications do so at their own risk and agree to fully indemnify MACOM for any damages resulting from such improper use or sale.

## Looking for pricing, stock, or lifecycle information?

Click below to explore more details on WIN SOURCE:

- ⊖ [View MA46477-134](#) on WIN SOURCE
- ⊖ [M/A-Com Technology Solutions](#) Information

## Optimize Your Supply Chain with WIN SOURCE Solutions

- ✓ Global Sourcing Solution
- ✓ Obsolete Management
- ✓ Cost Control Management
- ✓ Shortage Management
- ✓ Alternative Solution
- ✓ Excess Inventory Management