



**THE DATASHEET OF
EVAL-ADPD144RIZ-SF**



Evaluating the **ADPD144RI** PPG Optical Sensor Module with Integrated Red/IR Emitters and AFE

FEATURES

- Supports the detection of UART
- UDP transfer capability
- ADPD144RI** full configuration
 - Register level
 - High level
- Graph view
 - Time graph
 - Frequency graph

EVALUATION KIT CONTENTS

- EVAL-ADPD144RIZ-SF evaluation boards

ADDITIONAL EQUIPMENT NEEDED

- PC running Windows® 7 or Windows 10 operating system
- EVAL-ADPUCZ** microcontroller board

ONLINE RESOURCES

- ADPD144RI** data sheet
- Applications Wavetool software package

GENERAL DESCRIPTION

The EVAL-ADPD144RIZ-SF provides users with a means of evaluating the **ADPD144RI**, a complete photometric system designed to measure optical signals from ambient light and from synchronous, reflected light emitting diode (LED) pulses. The evaluation system includes the Applications Wavetool graphical user interface (GUI), which provides users with low level and high level configurability; real-time frequency and time domain analysis; and a user datagram protocol (UDP) transfer capability so that the evaluation board can easily connect to the user development system.

The EVAL-ADPD144RIZ-SF is a multiboard evaluation kit consisting of an adapter board and a sensor board connected by a 3 foot cable. The adapter board connects to the **EVAL-ADPUCZ** microcontroller board through a ribbon cable.

The evaluation board is optimized for ear-based photoplethysmography (PPG) measurements.

For additional information on the functionality of the **ADPD144RI**, see the **ADPD144RI** data sheet in conjunction with this user guide when using the EVAL-ADPD144RIZ-SF.

EVAL-ADPD144RIZ-SF EVALUATION KIT PHOTOGRAPH

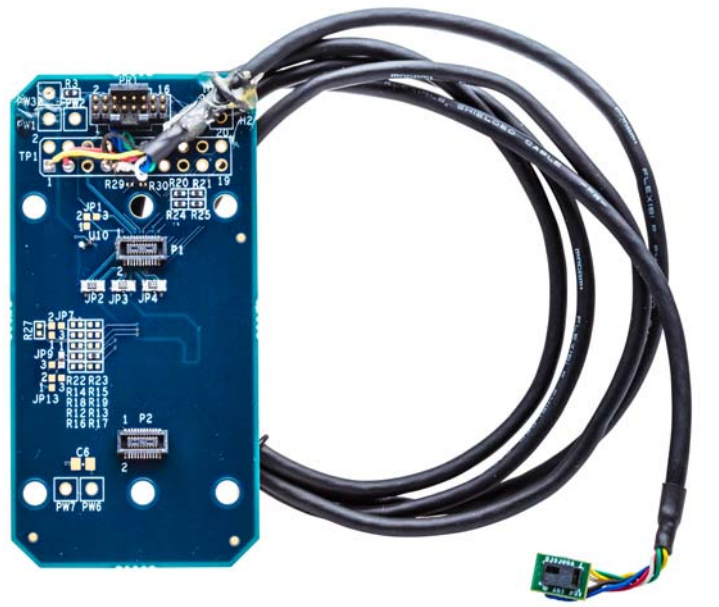

Figure 1.

TABLE OF CONTENTS

Features	1	Checking the USB Serial Connection in Windows	3
Evaluation Kit Contents.....	1	Updating the EVAL-ADPDDUCZ Firmware.....	3
Additional Equipment Needed.....	1	Acquiring Data.....	4
Online Resources	1	Running the Applications Wavetool.....	4
General Description	1	USB UART Connection.....	4
EVAL-ADPD144RIZ-SF Evaluation Kit Photograph.....	1	Selecting the Proper View	4
Revision History	2	Load Configuration	4
Getting Started	3	Optimizing and Running the ADPD144RI	5
Installing the Applications Wavetool.....	3	Evaluation Board Schematics and Artwork.....	6
Connecting the EVAL-ADPDUCZ Microcontroller Board and the EVAL-ADPD144RIZ-SF.....	3		

REVISION HISTORY

2/2019—Revision 0: Initial Version

GETTING STARTED

INSTALLING THE APPLICATIONS WAVETOOL

Download the Applications Wavetool software package from the EVAL-ADPD144RIZ-SF product page. Unzip the folder and run the Applications Wavetool executable file. Follow the prompts, beginning with the **Applications Wavetool Setup** window shown in Figure 2 for software installation. The Applications Wavetool is periodically updated to add features and improve performance. It is recommended that customers use the latest revision to take advantage of new features and performance.

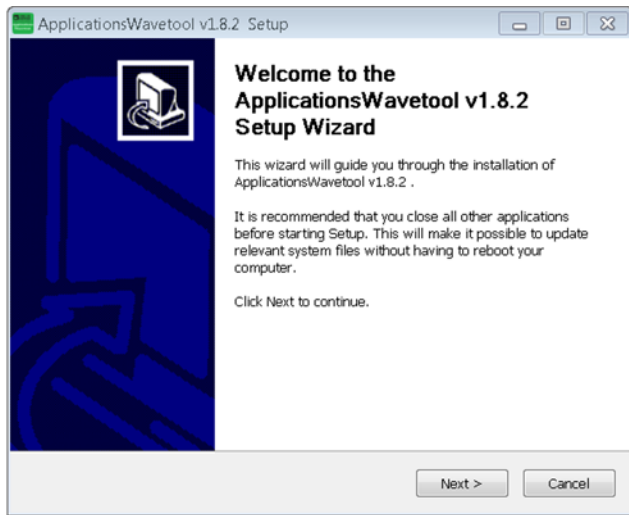

Figure 2. Applications Wavetool Setup

CONNECTING THE EVAL-ADPDUCZ MICROCONTROLLER BOARD AND THE EVAL-ADPD144RIZ-SF

Connect the USB cable to the **EVAL-ADPDUCZ** and the ribbon cable to the **EVAL-ADPD144RIZ-SF**. Switch the power switch to the ON position.

When the power switch is in the ON position, the LED near the power switch illuminates, indicating that the **EVAL-ADPDUCZ** microcontroller board is on. When the USB cable is connected to the **EVAL-ADPDUCZ**, the second LED near the power switch illuminates, indicating that the on-board battery is charging.

CHECKING THE USB SERIAL CONNECTION IN WINDOWS

Ensure that the communications port (COM port) driver is installed correctly. To verify proper installation, go to **Control Panel > All Control Panel Items > System > Device Manager**, as shown in Figure 3. In this case, the proper COM port choice is **USB Serial Port (COM16)**.

The EVAL-ADPDUCZ microcontroller board uses an FT232 USB, universal asynchronous receiver transmitter (UART) IC. If the USB driver does not install properly, refer to the FTDI driver installation guide that corresponds with the operating system in use.

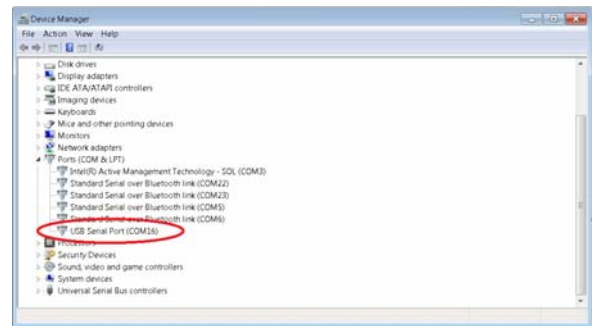

Figure 3. USB Serial Port in Windows 7

UPDATING THE EVAL-ADPDUCZ FIRMWARE

The **EVAL-ADPDUCZ** microcontroller board may have an older version of the firmware installed during manufacturing. If the user receives the message shown in Figure 4 when trying to connect to the Applications Wavetool, the **EVAL-ADPDUCZ** must be updated.



Figure 4. Firmware Out of Date Warning Prompt

Refer to the Applications Wavetool user guide that is provided in the software package download for instructions on updating the **EVAL-ADPDUCZ** firmware

ACQUIRING DATA

RUNNING THE APPLICATIONS WAVETOOL

To start the Applications Wavetool, navigate to the **Start** menu > **Analog Devices** > **ApplicationsWaveTool** and click **ApplicationsWavetool**.

USB UART CONNECTION

To establish the connection, follow the menu path **Connection** > **Connect** > **UART Bridge**.

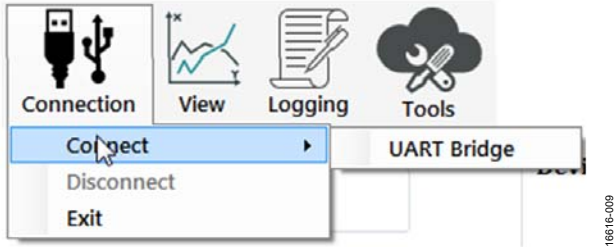

Figure 5. UART Connect

Select the proper COM port to connect the Applications Wavetool to the device. If connection via Bluetooth® is required, or if there are any other connection issues, refer to the Applications Wavetool user guide that is provided in the software package download.

SELECTING THE PROPER VIEW

The **ADPD144RI** is intended for nonwrist-based PPG measurements. Click the **ADPD Device** data view (see Figure 6) to open a window that allows the user to run the **ADPD144RI** device and collect data (see Figure 7).

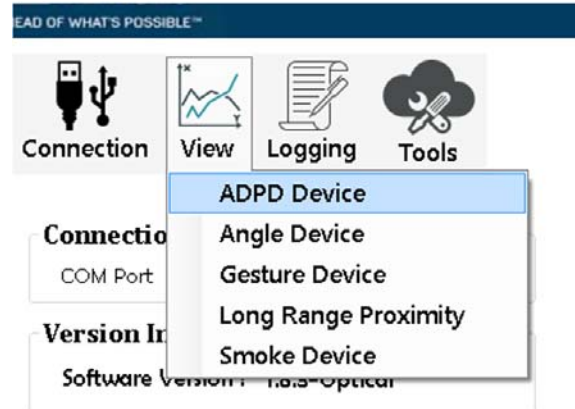

Figure 6. Click ADPD Device

LOAD CONFIGURATION

In the upper right corner of the data view window, click **ADPD Config** to open the **ADPD Config** window shown in Figure 7. Click **Load DCFG** to choose a configuration file. For PPG measurements, choose the **144RI_earbud.dcfg** configuration file.

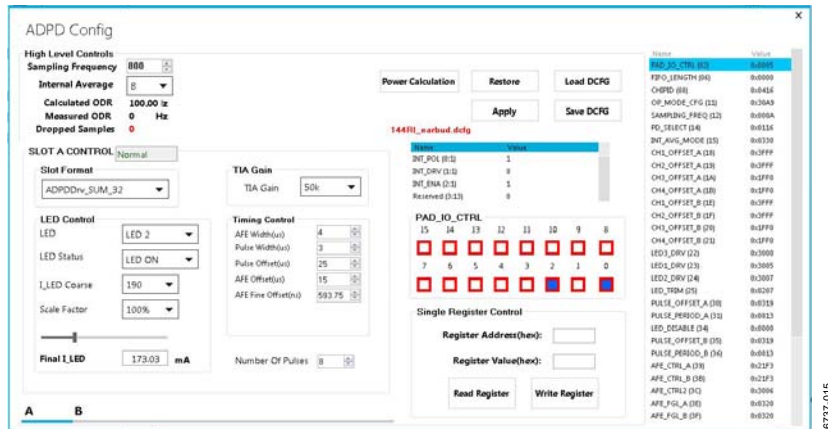

Figure 7. ADPD Config View

OPTIMIZING AND RUNNING THE ADPD144RI

After the configuration file is loaded, the settings can be further optimized using the **ADPD Config** window shown in Figure 7. Typically, the device is set up under a certain set of conditions, such as measuring the response from a fixed reflector or measuring a PPG signal from the ear (see Figure 8). Settings can be optimized for any set of conditions by manipulating LED drive currents, transimpedance amplifier (TIA) gain, and

analog front end (AFE) timing. Another option is to use different operating modes that can be more optimal for a specific set of conditions, such as using float mode for a low current transfer ratio (CTR). For information on optimization of the **ADPD144RI**, refer to the **ADPD144RI** data sheet. For functional descriptions of the Applications Wavetool, refer to the Applications Wavetool user guide provided in the software package download.



Figure 8. Example of a PPG Signal

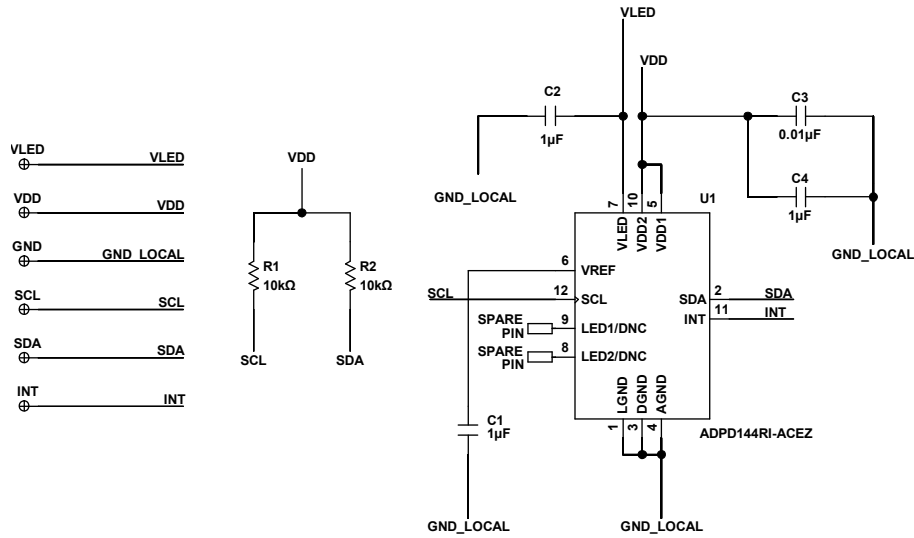

Figure 10. EVAL-ADPD144RIZ-SF BR-048911 Schematic

16737-018

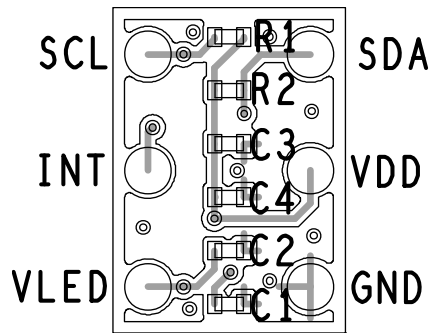

Figure 11. EVAL-ADPD144RIZ-SF BR-048911 Primary Layer

16737-019

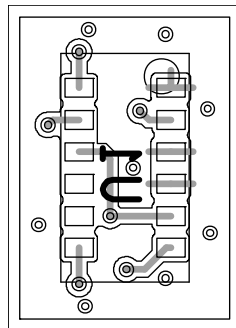

Figure 12. EVAL-ADPD144RIZ-SF BR-048911 Secondary Layer

16737-021

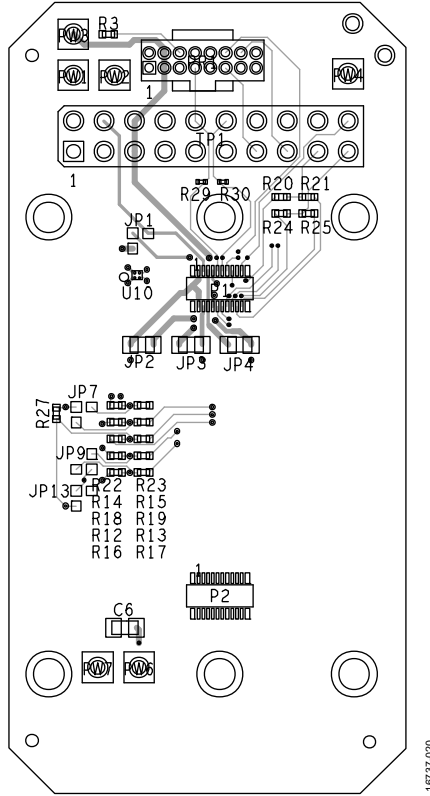

Figure 13. EVAL-ADPD144RIZ-SF BR-048862 Primary Layer

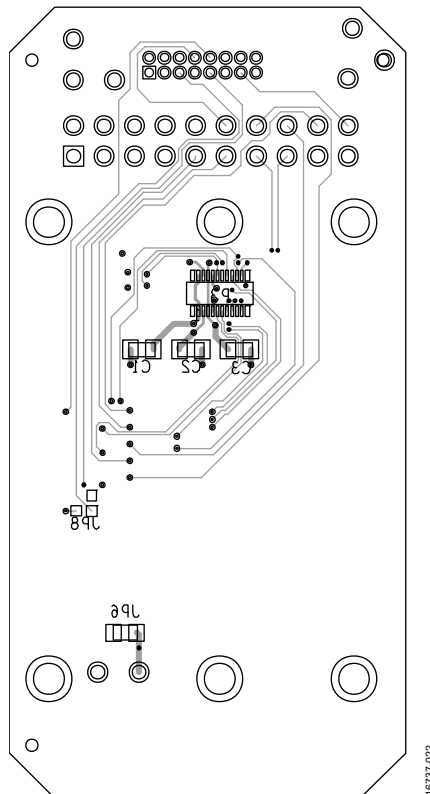

Figure 14. EVAL-ADPD144RIZ-SF BR-048862 Secondary Layer

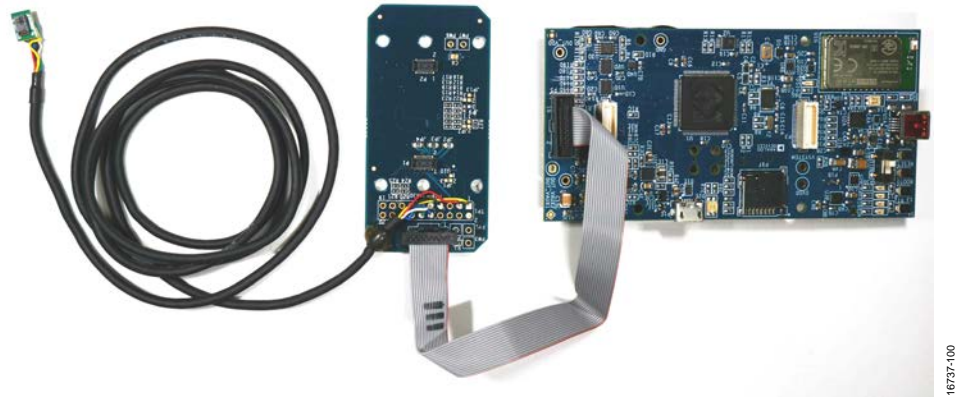

Figure 15. EVAL-ADPD144RIZ-SF Connected to the EVAL-ADPDUCZ Microcontroller Board

16737-100

NOTES

**ESD Caution**

ESD (electrostatic discharge) sensitive device. Charged devices and circuit boards can discharge without detection. Although this product features patented or proprietary protection circuitry, damage may occur on devices subjected to high energy ESD. Therefore, proper ESD precautions should be taken to avoid performance degradation or loss of functionality.

Legal Terms and Conditions

By using the evaluation board discussed herein (together with any tools, components documentation or support materials, the "Evaluation Board"), you are agreeing to be bound by the terms and conditions set forth below ("Agreement") unless you have purchased the Evaluation Board, in which case the Analog Devices Standard Terms and Conditions of Sale shall govern. Do not use the Evaluation Board until you have read and agreed to the Agreement. Your use of the Evaluation Board shall signify your acceptance of the Agreement. This Agreement is made by and between you ("Customer") and Analog Devices, Inc. ("ADI"), with its principal place of business at One Technology Way, Norwood, MA 02062, USA. Subject to the terms and conditions of the Agreement, ADI hereby grants to Customer a free, limited, personal, temporary, non-exclusive, non-sublicensable, non-transferable license to use the Evaluation Board FOR EVALUATION PURPOSES ONLY. Customer understands and agrees that the Evaluation Board is provided for the sole and exclusive purpose referenced above, and agrees not to use the Evaluation Board for any other purpose. Furthermore, the license granted is expressly made subject to the following additional limitations: Customer shall not (i) rent, lease, display, sell, transfer, assign, sublicense, or distribute the Evaluation Board; and (ii) permit any Third Party to access the Evaluation Board. As used herein, the term "Third Party" includes any entity other than ADI, Customer, their employees, affiliates and in-house consultants. The Evaluation Board is NOT sold to Customer; all rights not expressly granted herein, including ownership of the Evaluation Board, are reserved by ADI. CONFIDENTIALITY. This Agreement and the Evaluation Board shall all be considered the confidential and proprietary information of ADI. Customer may not disclose or transfer any portion of the Evaluation Board to any other party for any reason. Upon discontinuation of use of the Evaluation Board or termination of this Agreement, Customer agrees to promptly return the Evaluation Board to ADI. ADDITIONAL RESTRICTIONS. Customer may not disassemble, decompile or reverse engineer chips on the Evaluation Board. Customer shall inform ADI of any occurred damages or any modifications or alterations it makes to the Evaluation Board, including but not limited to soldering or any other activity that affects the material content of the Evaluation Board. Modifications to the Evaluation Board must comply with applicable law, including but not limited to the RoHS Directive. TERMINATION. ADI may terminate this Agreement at any time upon giving written notice to Customer. Customer agrees to return to ADI the Evaluation Board at that time. LIMITATION OF LIABILITY. THE EVALUATION BOARD PROVIDED HEREUNDER IS PROVIDED "AS IS" AND ADI MAKES NO WARRANTIES OR REPRESENTATIONS OF ANY KIND WITH RESPECT TO IT. ADI SPECIFICALLY DISCLAIMS ANY REPRESENTATIONS, ENDORSEMENTS, GUARANTEES, OR WARRANTIES, EXPRESS OR IMPLIED, RELATED TO THE EVALUATION BOARD INCLUDING, BUT NOT LIMITED TO, THE IMPLIED WARRANTY OF MERCHANTABILITY, TITLE, FITNESS FOR A PARTICULAR PURPOSE OR NON-INFRINGEMENT OF INTELLECTUAL PROPERTY RIGHTS. IN NO EVENT WILL ADI AND ITS LICENSORS BE LIABLE FOR ANY INCIDENTAL, SPECIAL, INDIRECT, OR CONSEQUENTIAL DAMAGES RESULTING FROM CUSTOMER'S POSSESSION OR USE OF THE EVALUATION BOARD, INCLUDING BUT NOT LIMITED TO LOST PROFITS, DELAY COSTS, LABOR COSTS OR LOSS OF GOODWILL. ADI'S TOTAL LIABILITY FROM ANY AND ALL CAUSES SHALL BE LIMITED TO THE AMOUNT OF ONE HUNDRED US DOLLARS (\$100.00). EXPORT. Customer agrees that it will not directly or indirectly export the Evaluation Board to another country, and that it will comply with all applicable United States federal laws and regulations relating to exports. GOVERNING LAW. This Agreement shall be governed by and construed in accordance with the substantive laws of the Commonwealth of Massachusetts (excluding conflict of law rules). Any legal action regarding this Agreement will be heard in the state or federal courts having jurisdiction in Suffolk County, Massachusetts, and Customer hereby submits to the personal jurisdiction and venue of such courts. The United Nations Convention on Contracts for the International Sale of Goods shall not apply to this Agreement and is expressly disclaimed.

©2019 Analog Devices, Inc. All rights reserved. Trademarks and registered trademarks are the property of their respective owners.
UG16737-0-2/19(0)



www.analog.com

Looking for pricing, stock, or lifecycle information?

Click below to explore more details on WIN SOURCE:

- ⊖ [View EVAL-ADPD144RIZ-SF on WIN SOURCE](#)
- ⊖ [Analog Devices Inc. Information](#)

Optimize Your Supply Chain with WIN SOURCE Solutions

- ✓ Global Sourcing Solution
- ✓ Obsolete Management
- ✓ Cost Control Management
- ✓ Shortage Management
- ✓ Alternative Solution
- ✓ Excess Inventory Management