



**THE DATASHEET OF
DS160PR412RUAR**



DRV89xx-Q1 Automotive Multi-Channel Half-Bridge Drivers with Advanced Diagnostics

1 Features

- AEC-Q100 qualified for automotive applications
- 4, 6, 8, 10 and 12 half-bridge outputs
- 4.5-V to 32-V operating voltage
 - 40-V absolute maximum voltage
- 1-A RMS current for each output
 - 6-A maximum current for paralleled outputs
- Low-power sleep mode (1.5- μ A)
- Supports 3.3-V and 5-V logic inputs
- SPI for configuration and diagnostics
 - 5-MHz, 16-Bit SPI communication
 - Daisy chain functionality
- PWM generators programmable over SPI
 - Individual half-bridge PWM operation
 - Configurable for high-side, low-side, and H-bridge load driving
 - Supports 8-bit duty cycle resolution
- Integrated protection features with per channel detailed diagnostics over SPI
 - nFAULT pin output
 - VM undervoltage lockout (UVLO)
 - VM overvoltage protection (OVP)
 - Logic supply power on reset (POR)
 - Overcurrent protection (OCP)
 - Enhanced open load detection (OLD)
 - Thermal warning and shutdown (OTW/OTSD)

2 Applications

- [HVAC flap DC motors](#)
- [Side mirror adjustment and mirror fold](#)
- [LED applications](#)
- [Multiple brushed DC motors and solenoids](#)

3 Description

The DRV89xx-Q1 is a pin-to-pin compatible family of integrated multi-channel half-bridge drivers with 4 to 12 half-bridges. The device family features low on-state resistance ($R_{DS(ON)}$) for improved thermal performance during high-current operation.

These devices can drive brushed-DC (BDC) motors or stepper motors in independent, sequential, or parallel mode. The half-bridges are fully controllable to achieve a forward, reverse, coasting and braking operation of motor.

These devices feature standard 16-bit, 5-MHz serial peripheral interface (SPI) with daisy chain capability for complete configuration and detailed diagnostics. Depending on the device, four or eight programmable PWM generators are integrated to allow for current limiting during motor operation or LED dimming control.

The device includes numerous protection and diagnostic features including an nFAULT pin to alert the system when a fault occurs. The device features a low-current open load detection (OLD) mode to detect open-load conditions when the nominal load current is small and a passive OLD mode for offline OLD. The device is also fully-protected from short-circuit, undervoltage, and over-temperature conditions.

View our full portfolio of [brushed motor drivers](#) on [ti.com](#).

Device Information⁽¹⁾

PART NUMBER	PACKAGE	BODY SIZE (NOM)
DRV8912-Q1	HTSSOP (24)	7.80 mm x 4.40 mm
DRV8910-Q1		
DRV8908-Q1		
DRV8906-Q1		
DRV8904-Q1		

(1) For all available packages, see the orderable addendum at the end of the data sheet.

Simplified Schematic

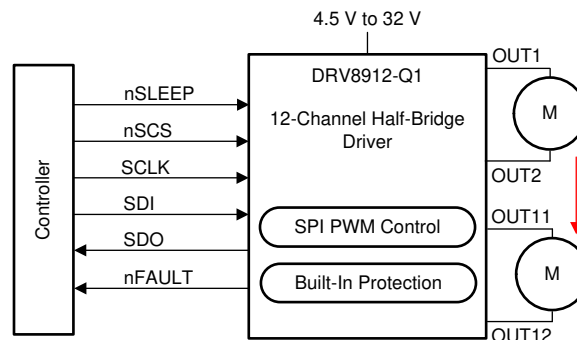

Table of Contents

1 Features	1	8.6 Register Map	63
2 Applications	1	9 Application and Implementation	129
3 Description	1	9.1 Application Information	129
4 Revision History	2	9.2 Typical Application	130
5 Device Comparison Table	3	9.3 Thermal Application	135
6 Pin Configuration and Functions	4	10 Power Supply Recommendations	141
7 Specifications	14	10.1 Bulk Capacitance Sizing	141
7.1 Absolute Maximum Ratings	14	11 Layout	142
7.2 ESD Ratings	14	11.1 Layout Guidelines	142
7.3 Recommended Operating Conditions	14	11.2 Layout Example	142
7.4 Thermal Information	14	12 Device and Documentation Support	143
7.5 Electrical Characteristics	15	12.1 Documentation Support	143
7.6 Timing Requirements	18	12.2 Related Links	143
7.7 Typical Characteristics	20	12.3 Receiving Notification of Documentation Updates	143
8 Detailed Description	25	12.4 Community Resources	143
8.1 Overview	25	12.5 Trademarks	143
8.2 Functional Block Diagram	26	12.6 Electrostatic Discharge Caution	143
8.3 Feature Description	27	12.7 Glossary	143
8.4 Device Functional Modes	57	13 Mechanical, Packaging, and Orderable Information	143
8.5 Programming	59		

4 Revision History

NOTE: Page numbers for previous revisions may differ from page numbers in the current version.

Changes from Revision B (December 2019) to Revision C	Page
• Changed Test Conditions for t_{PD}	16
• Added MIN/MAX specs for f_{PWM}	16
• Added MIN/MAX specs for t_{OCP}	17
• Changed $I_{OL_VM/GND}$ $V_{OL_VM/GND}$ specs based on production test data for DRV8908/06/04 product release	17
• Changed Figure 2 and Figure 3 with new data	20
• Added Figure 61 and Figure 62	47

Changes from Revision A (December 2019) to Revision B	Page
• Changed device status to Production Mixed	1

Changes from Original (September 2019) to Revision A	Page
• Changed device status to Production Data	1

5 Device Comparison Table

DEVICE	NUMBER OF HALF-BRIDGES	NUMBER OF PWM GENERATORS	OPEN-LOAD DETECTION SCHEMES	LINK TO REGISTER MAP
DRV8912-Q1	12	4	Active OLD, Low-Current Active OLD, Negative-Current Active OLD	Table 17
DRV8910-Q1	10	4		Table 18
DRV8908-Q1	8	8	Passive OLD, Active OLD, Low-Current Active OLD, Negative-Current Active OLD	Table 50
DRV8906-Q1	6	8		Table 51
DRV8904-Q1	4	8		Table 52

6 Pin Configuration and Functions

DRV8912-Q1 PWP Package
 24-Pin HTSSOP Package With Exposed Thermal Pad
 Top View

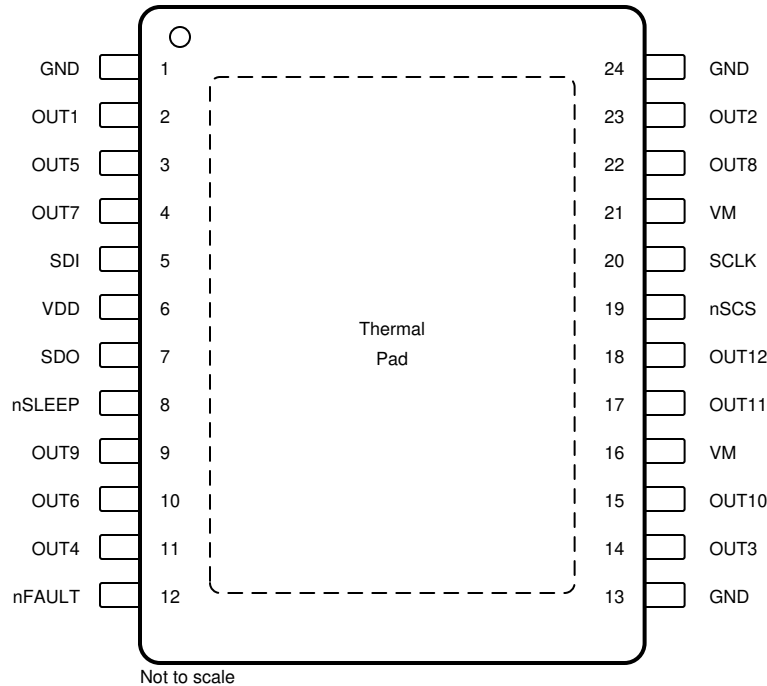

Pin Functions—DRV8912-Q1

PIN		TYPE	DESCRIPTION
NAME	NO.		
GND	13	PWR	Device power ground. Connect the GND pin to the system ground.
GND	24	PWR	Device power ground. Connect the GND pin to the system ground.
GND	1	PWR	Device power ground. Connect the GND pin to the system ground.
nFAULT	12	OD	Fault indicator output. This pin is pulled logic low during a fault condition and requires an external pull-up resistor.
nSCS	19	I	Serial chip select. A logic low on this pin enables serial interface communication. Internal pull-up.
nSLEEP	8	I	Driver enable pin. When this pin is logic low the device goes to a low-power sleep mode. Internal pull-down.
OUT1	2	O	Half-bridge 1 output
OUT2	23	O	Half-bridge 2 output
OUT3	14	O	Half-bridge 3 output
OUT4	11	O	Half-bridge 4 output
OUT5	3	O	Half-bridge 5 output
OUT6	10	O	Half-bridge 6 output
OUT7	4	O	Half-bridge 7 output
OUT8	22	O	Half-bridge 8 output
OUT9	9	O	Half-bridge 9 output
OUT10	15	O	Half-bridge 10 output
OUT11	17	O	Half-bridge 11 output
OUT12	18	O	Half-bridge 12 output

Pin Functions—DRV8912-Q1 (continued)

PIN		TYPE	DESCRIPTION
NAME	NO.		
SCLK	20	I	Serial clock input. Serial data is shifted out and captured on the corresponding rising and falling edge on this pin. Internal pull-down.
SDI	5	I	Serial data input. Data is captured on the falling edge of the SCLK pin. Internal pull-down.
SDO	7	O	Serial data output. Data is shifted out on the rising edge of the SCLK pin.
VDD	6	PWR	Logic power supply input. Connect a X5R or X7R, 0.1- μ F, VDD-rated ceramic capacitor and greater than or equal to 1- μ F bulk capacitance between the VDD and GND pins.
VM	16	PWR	Main power supply input. Connect all VM pins together to the motor supply voltage. Connect a X5R or X7R, 0.1- μ F, VM-rated ceramic capacitor and greater than or equal to 10- μ F bulk capacitance between the VM and GND pins.
VM	21	PWR	Main power supply input. Connect all VM pins together to the motor supply voltage. Connect a X5R or X7R, 0.1- μ F, VM-rated ceramic capacitor and greater than or equal to 10- μ F bulk capacitance between the VM and GND pins.

DRV8910-Q1 PWP Package
 24-Pin HTSSOP Package With Exposed Thermal Pad
 Top View

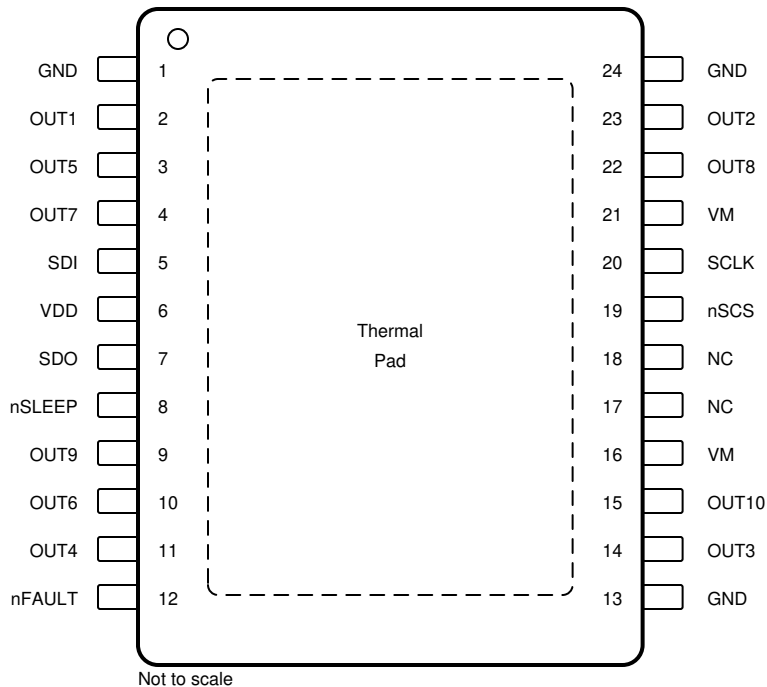

Pin Functions—DRV8910-Q1

PIN		TYPE	DESCRIPTION
NAME	NO.		
GND	13	PWR	Device power ground. Connect the GND pin to the system ground.
GND	24	PWR	Device power ground. Connect the GND pin to the system ground.
GND	1	PWR	Device power ground. Connect the GND pin to the system ground.
NC	17	—	Not connected
NC	18	—	Not connected
nFAULT	12	OD	Fault indicator output. This pin is pulled logic low during a fault condition and requires an external pull-up resistor.
nSCS	19	I	Serial chip select. A logic low on this pin enables serial interface communication. Internal pull-up.
nSLEEP	8	I	Driver enable pin. When this pin is logic low the device goes to a low-power sleep mode. Internal pull-down.
OUT1	2	O	Half-bridge 1 output
OUT2	23	O	Half-bridge 2 output
OUT3	14	O	Half-bridge 3 output
OUT4	11	O	Half-bridge 4 output
OUT5	3	O	Half-bridge 5 output
OUT6	10	O	Half-bridge 6 output
OUT7	4	O	Half-bridge 7 output
OUT8	22	O	Half-bridge 8 output
OUT9	9	O	Half-bridge 9 output
OUT10	15	O	Half-bridge 10 output
SCLK	20	I	Serial clock input. Serial data is shifted out and captured on the corresponding rising and falling edge on this pin. Internal pull-down.
SDI	5	I	Serial data input. Data is captured on the falling edge of the SCLK pin. Internal pull-down.

Pin Functions—DRV8910-Q1 (continued)

PIN		TYPE	DESCRIPTION
NAME	NO.		
SDO	7	O	Serial data output. Data is shifted out on the rising edge of the SCLK pin.
VDD	6	PWR	Logic power supply input. Connect a X5R or X7R, 0.1- μ F, VDD-rated ceramic capacitor and greater than or equal to 1- μ F bulk capacitance between the VDD and GND pins.
VM	16	PWR	Main power supply input. Connect all VM pins together to the motor supply voltage. Connect a X5R or X7R, 0.1- μ F, VM-rated ceramic capacitor and greater than or equal to 10- μ F bulk capacitance between the VM and GND pins.
VM	21	PWR	Main power supply input. Connect all VM pins together to the motor supply voltage. Connect a X5R or X7R, 0.1- μ F, VM-rated ceramic capacitor and greater than or equal to 10- μ F bulk capacitance between the VM and GND pins.

DRV8908-Q1 PWP Package
 24-Pin HTSSOP Package With Exposed Thermal Pad
 Top View

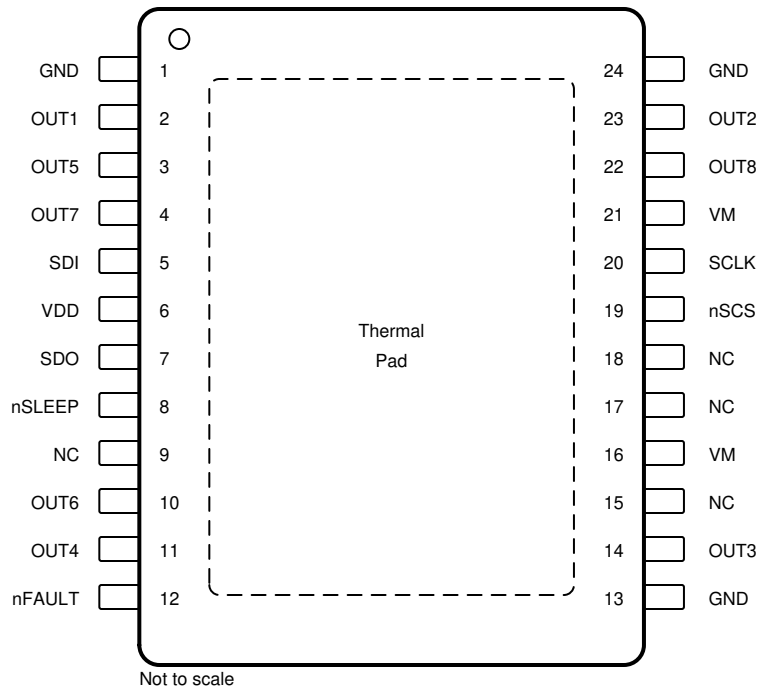

Pin Functions—DRV8908-Q1

PIN		TYPE	DESCRIPTION
NAME	NO.		
GND	13	PWR	Device power ground. Connect the GND pin to the system ground.
GND	24	PWR	Device power ground. Connect the GND pin to the system ground.
GND	1	PWR	Device power ground. Connect the GND pin to the system ground.
NC	9	—	Not connected
NC	15	—	Not connected
NC	17	—	Not connected
NC	18	—	Not connected
nFAULT	12	OD	Fault indicator output. This pin is pulled logic low during a fault condition and requires an external pull-up resistor.
nSCS	19	I	Serial chip select. A logic low on this pin enables serial interface communication. Internal pull-up.
nSLEEP	8	I	Driver enable pin. When this pin is logic low the device goes to a low-power sleep mode. Internal pull-down.
OUT1	2	O	Half-bridge 1 output
OUT2	23	O	Half-bridge 2 output
OUT3	14	O	Half-bridge 3 output
OUT4	11	O	Half-bridge 4 output
OUT5	3	O	Half-bridge 5 output
OUT6	10	O	Half-bridge 6 output
OUT7	4	O	Half-bridge 7 output
OUT8	22	O	Half-bridge 8 output
SCLK	20	I	Serial clock input. Serial data is shifted out and captured on the corresponding rising and falling edge on this pin. Internal pull-down.
SDI	5	I	Serial data input. Data is captured on the falling edge of the SCLK pin. Internal pull-down.

Pin Functions—DRV8908-Q1 (continued)

PIN		TYPE	DESCRIPTION
NAME	NO.		
SDO	7	O	Serial data output. Data is shifted out on the rising edge of the SCLK pin.
VDD	6	PWR	Logic power supply input. Connect a X5R or X7R, 0.1- μ F, VDD-rated ceramic capacitor and greater than or equal to 1- μ F bulk capacitance between the VDD and GND pins.
VM	16	PWR	Main power supply input. Connect all VM pins together to the motor supply voltage. Connect a X5R or X7R, 0.1- μ F, VM-rated ceramic capacitor and greater than or equal to 10- μ F bulk capacitance between the VM and GND pins.
VM	21	PWR	Main power supply input. Connect all VM pins together to the motor supply voltage. Connect a X5R or X7R, 0.1- μ F, VM-rated ceramic capacitor and greater than or equal to 10- μ F bulk capacitance between the VM and GND pins.

DRV8906-Q1 PWP Package
 24-Pin HTSSOP Package With Exposed Thermal Pad
 Top View

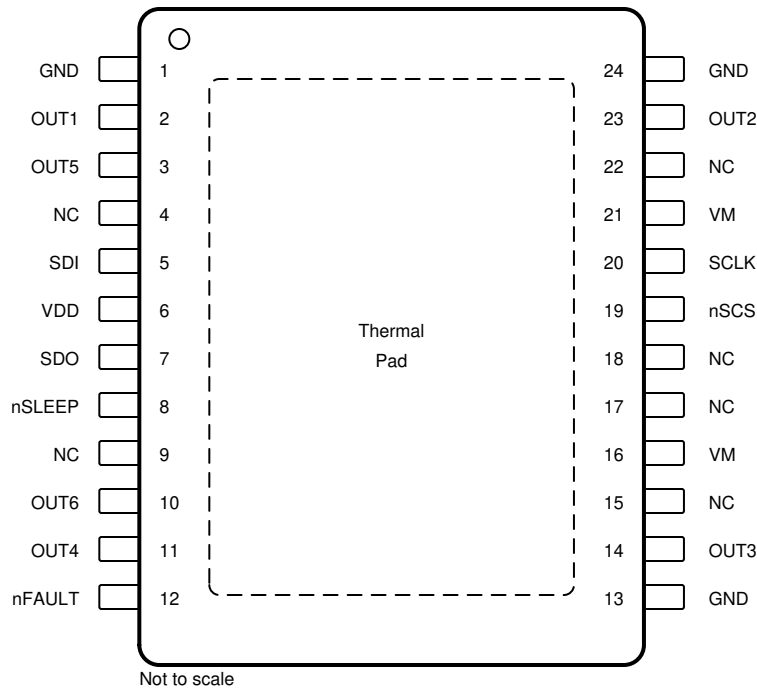

Pin Functions—DRV8906-Q1

PIN		TYPE	DESCRIPTION
NAME	NO.		
GND	13	PWR	Device power ground. Connect the GND pin to the system ground.
GND	24	PWR	Device power ground. Connect the GND pin to the system ground.
GND	1	PWR	Device power ground. Connect the GND pin to the system ground.
NC	4	—	Not connected
NC	9	—	Not connected
NC	15	—	Not connected
NC	17	—	Not connected
NC	18	—	Not connected
NC	22	—	Not connected
nFAULT	12	OD	Fault indicator output. This pin is pulled logic low during a fault condition and requires an external pull-up resistor.
nSCS	19	I	Serial chip select. A logic low on this pin enables serial interface communication. Internal pull-up.
nSLEEP	8	I	Driver enable pin. When this pin is logic low the device goes to a low-power sleep mode. Internal pull-down.
OUT1	2	O	Half-bridge 1 output
OUT2	23	O	Half-bridge 2 output
OUT3	14	O	Half-bridge 3 output
OUT4	11	O	Half-bridge 4 output
OUT5	3	O	Half-bridge 5 output
OUT6	10	O	Half-bridge 6 output
SCLK	20	I	Serial clock input. Serial data is shifted out and captured on the corresponding rising and falling edge on this pin. Internal pull-down.
SDI	5	I	Serial data input. Data is captured on the falling edge of the SCLK pin. Internal pull-down.

Pin Functions—DRV8906-Q1 (continued)

PIN		TYPE	DESCRIPTION
NAME	NO.		
SDO	7	O	Serial data output. Data is shifted out on the rising edge of the SCLK pin.
VDD	6	PWR	Logic power supply input. Connect a X5R or X7R, 0.1- μ F, VDD-rated ceramic capacitor and greater than or equal to 1- μ F bulk capacitance between the VDD and GND pins.
VM	16	PWR	Main power supply input. Connect all VM pins together to the motor supply voltage. Connect a X5R or X7R, 0.1- μ F, VM-rated ceramic capacitor and greater than or equal to 10- μ F bulk capacitance between the VM and GND pins.
VM	21	PWR	Main power supply input. Connect all VM pins together to the motor supply voltage. Connect a X5R or X7R, 0.1- μ F, VM-rated ceramic capacitor and greater than or equal to 10- μ F bulk capacitance between the VM and GND pins.

DRV8904-Q1 PWP Package
 24-Pin HTSSOP Package With Exposed Thermal Pad
 Top View

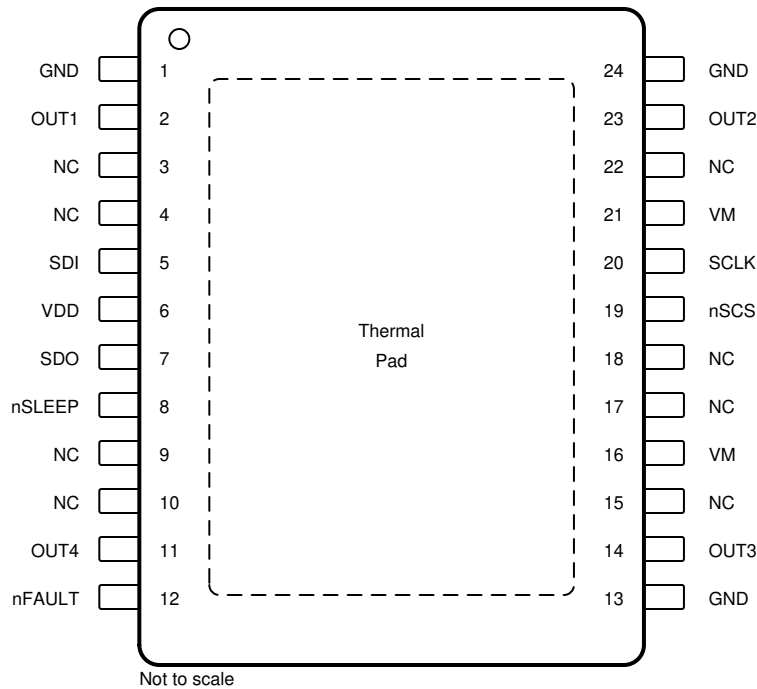

Pin Functions—DRV8904-Q1

PIN		TYPE	DESCRIPTION
NAME	NO.		
GND	13	PWR	Device power ground. Connect the GND pin to the system ground.
GND	24	PWR	Device power ground. Connect the GND pin to the system ground.
GND	1	PWR	Device power ground. Connect the GND pin to the system ground.
NC	3	—	Not connected
NC	4	—	Not connected
NC	9	—	Not connected
NC	10	—	Not connected
NC	15	—	Not connected
NC	17	—	Not connected
NC	18	—	Not connected
NC	22	—	Not connected
nFAULT	12	OD	Fault indicator output. This pin is pulled logic low during a fault condition and requires an external pull-up resistor.
nSCS	19	I	Serial chip select. A logic low on this pin enables serial interface communication. Internal pull-up.
nSLEEP	8	I	Driver enable pin. When this pin is logic low the device goes to a low-power sleep mode. Internal pull-down.
OUT1	2	O	Half-bridge 1 output
OUT2	23	O	Half-bridge 2 output
OUT3	14	O	Half-bridge 3 output
OUT4	11	O	Half-bridge 4 output
SCLK	20	I	Serial clock input. Serial data is shifted out and captured on the corresponding rising and falling edge on this pin. Internal pull-down.
SDI	5	I	Serial data input. Data is captured on the falling edge of the SCLK pin. Internal pull-down.

Pin Functions—DRV8904-Q1 (continued)

PIN		TYPE	DESCRIPTION
NAME	NO.		
SDO	7	O	Serial data output. Data is shifted out on the rising edge of the SCLK pin.
VDD	6	PWR	Logic power supply input. Connect a X5R or X7R, 0.1- μ F, VDD-rated ceramic capacitor and greater than or equal to 1- μ F bulk capacitance between the VDD and GND pins.
VM	16	PWR	Main power supply input. Connect all VM pins together to the motor supply voltage. Connect a X5R or X7R, 0.1- μ F, VM-rated ceramic capacitor and greater than or equal to 10- μ F bulk capacitance between the VM and GND pins.
VM	21	PWR	Main power supply input. Connect all VM pins together to the motor supply voltage. Connect a X5R or X7R, 0.1- μ F, VM-rated ceramic capacitor and greater than or equal to 10- μ F bulk capacitance between the VM and GND pins.

7 Specifications

7.1 Absolute Maximum Ratings

over operating ambient temperature range (unless otherwise noted)⁽¹⁾

	MIN	MAX	UNIT
Power supply pin voltage (VM)	4.5	40	V
Logic supply pin voltage (VDD)	-0.3	5.75	V
Output pin voltage (OUTx)	-0.7	VM + 0.7	V
Logic pin input voltage (nSCS, nSLEEP, SCLK, SDI)	-0.3	VDD + 0.3	V
Logic pin output voltage (nFAULT, SDO)	-0.3	VDD + 0.3	V
Continuous supply current (VM pins combined)	0	6	A
Peak output current drive (OUTx)	Internally Limited	Internally Limited	A
Continuous sink current (GND pins combined)	0	6	A
Junction temperature, T _J	-40	150	°C
Storage temperature, T _{stg}	-65	150	°C

(1) Stresses beyond those listed under *Absolute Maximum Rating* may cause permanent damage to the device. These are stress ratings only, which do not imply functional operation of the device at these or any other conditions beyond those indicated under *Recommended Operating Condition*. Exposure to absolute-maximum-rated conditions for extended periods may affect device reliability.

7.2 ESD Ratings

				VALUE	UNIT
V _(ESD)	Electrostatic discharge	Human body model (HBM), per AEC Q100-002 ⁽¹⁾	OUTx and VM pins	±4000	V
			Other pins	±2000	
		Charged device model (CDM), per AEC Q100-011	Corner pins (1, 12, 13, and 24)	±750	
			Other pins	±500	

(1) AEC Q100-002 indicates that HBM stressing shall be in accordance with the ANSI/ESDA/JEDEC JS-001 specification.

7.3 Recommended Operating Conditions

over operating ambient temperature range (unless otherwise noted)

		MIN	NOM	MAX	UNIT
V _{VM}	Power supply voltage (VM)	4.5		32	V
V _{DD}	Logic supply voltage (VDD)	3		5.5	V
V _{IN}	Logic input voltage (nSCS, nSLEEP, SCLK, SDI)	0		5.5	V
V _{OD}	Open drain pullup voltage (nFAULT)	0		5.5	V
I _{OD}	Open drain output current (nFAULT)	0		5	mA
V _{OP}	Push-pull pullup voltage (SDO)	0		5.5	V
I _{OP}	Push-pull output current (SDO)	0		5	mA
T _A	Operating ambient temperature	-40		125	°C
T _J	Operating junction temperature	-40		150	°C

7.4 Thermal Information

THERMAL METRIC ⁽¹⁾		DRV8912-Q1 DRV8910-Q1	DRV8908-Q1 DRV8906-Q1 DRV8904-Q1	UNIT
		PWP (HTSSOP)	PWP (HTSSOP)	
		24 PINS	24 PINS	
R _{θJA}	Junction-to-ambient thermal resistance	30.2	31.2	°C/W
R _{θJC(top)}	Junction-to-case (top) thermal resistance	23.7	25.4	°C/W
R _{θJB}	Junction-to-board thermal resistance	10.1	11.2	°C/W

(1) For more information about traditional and new thermal metrics, see [Semiconductor and IC Package Thermal Metrics](#) application report.

Thermal Information (continued)

THERMAL METRIC ⁽¹⁾		DRV8912-Q1 DRV8910-Q1	DRV8908-Q1 DRV8906-Q1 DRV8904-Q1	UNIT
		PWP (HTSSOP)	PWP (HTSSOP)	
		24 PINS	24 PINS	
Ψ_{JT}	Junction-to-top characterization parameter	0.3	0.4	°C/W
Ψ_{JB}	Junction-to-board characterization parameter	10.0	11.2	°C/W
$R_{\theta JC(bot)}$	Junction-to-case (bottom) thermal resistance	2.5	3.1	°C/W

7.5 Electrical Characteristics

at $T_J = -40^{\circ}\text{C}$ to $+150^{\circ}\text{C}$, $V_{VM} = 4.5$ to 32 V (Main Supply), $V_{VDD} = 3$ to 5.5 V (Logic Supply) (unless otherwise noted). Typical limits apply for $T_A = 25^{\circ}\text{C}$, $V_{VM} = 13.5$ V, $V_{VDD} = 3.3$ V

PARAMETER		TEST CONDITIONS	MIN	TYP	MAX	UNIT
POWER SUPPLIES (VDD, VM)						
I_{VMQ}	VM sleep mode current	$V_{VM} = 13.5$ V, nSLEEP = 0, $T_A = 25^{\circ}\text{C}$		0.35	1	μA
		$V_{VM} = 13.5$ V, nSLEEP = 0, $T_A = 125^{\circ}\text{C}$			2	μA
I_{VDDQ}	VDD sleep mode current	$V_{VM} = 13.5$ V, $V_{VDD} = 3.3$ V, nSLEEP = 0, $T_A = 25^{\circ}\text{C}$		0.01	0.3	μA
		$V_{VM} = 13.5$ V, $V_{VDD} = 3.3$ V, nSLEEP = 0, $T_A = 125^{\circ}\text{C}$			2	μA
I_{VMS}	VM standby mode current	$V_{VM} = 13.5$ V, nSLEEP = 1, Driver = 'OFF', $T_A = 25^{\circ}\text{C}$		0.2	0.5	mA
		$V_{VM} = 13.5$ V, nSLEEP = 1, Driver = 'OFF', $T_A = 125^{\circ}\text{C}$			0.5	mA
I_{VDDS}	VDD standby mode current	$V_{VM} = 13.5$ V, $V_{VDD} = 3.3$ V, nSLEEP = 1, SPI = 'OFF', $T_A = 25^{\circ}\text{C}$		0.6	1	mA
		$V_{VM} = 13.5$ V, $V_{VDD} = 3.3$ V, nSLEEP = 1, SPI = 'OFF', $T_A = 125^{\circ}\text{C}$			1	mA
I_{VM}	VM operating mode current	$V_{VM} = 13.5$ V, nSLEEP = 1, All High-Side FETs = 'ON', $T_A = 25^{\circ}\text{C}$		2.6	5	mA
		$V_{VM} = 13.5$ V, nSLEEP = 1, All High-Side FETs = 'ON', $T_A = 125^{\circ}\text{C}$			5	mA
I_{VDD}	VDD operating mode current	$V_{VM} = 13.5$ V, $V_{VDD} = 3.3$ V, nSLEEP = 1, All High-Side FETs = 'ON', SPI = 'ON' (5 MHz), $T_A = 25^{\circ}\text{C}$		2.8	5	mA
		$V_{VM} = 13.5$ V, $V_{VDD} = 3.3$ V, nSLEEP = 1, All High-Side FETs = 'ON', SPI = 'ON' (5 MHz), $T_A = 125^{\circ}\text{C}$			5	mA
t_{WAKE}	Wake-up time	nSLEEP high to SPI ready			200	μs
t_{SLEEP}	Turnoff time	nSLEEP low to device sleep			20	μs
LOGIC-LEVEL INPUTS (nSLEEP, SCLK, SDI)						
V_{IL}	Input logic low voltage		0		$0.3 \cdot V_{VDD}$	V
V_{IH}	Input logic high voltage		$0.7 \cdot V_{VDD}$		VDD	V
V_{HYS}	Input logic hysteresis		200			mV
I_{iL}	Input logic low current	$V_{IN} = 0$ V	-1		1	μA
I_{iH}	Input logic high current	$V_{IN} = V_{VDD}$		34	75	μA
C_{ID}	Input capacitance				15	pF
LOGIC-LEVEL INPUTS (nSCS)						
V_{IL}	Input logic low voltage		0		$0.3 \cdot V_{VDD}$	V
V_{IH}	Input logic high voltage		$0.7 \cdot V_{VDD}$		VDD	V
V_{HYS}	Input logic hysteresis		200			mV
I_{iL}	Input logic low current	$V_{IN} = 0$ V		34	75	μA

Electrical Characteristics (continued)

at $T_J = -40^{\circ}\text{C}$ to $+150^{\circ}\text{C}$, $V_{VM} = 4.5$ to 32 V (Main Supply), $V_{VDD} = 3$ to 5.5 V (Logic Supply) (unless otherwise noted). Typical limits apply for $T_A = 25^{\circ}\text{C}$, $V_{VM} = 13.5$ V, $V_{VDD} = 3.3$ V

PARAMETER		TEST CONDITIONS	MIN	TYP	MAX	UNIT
I_{IH}	Input logic high current	$V_{IN} = V_{VDD}$	-1		1	μA
C_{ID}	Input capacitance				15	pF
OPEN-DRAIN OUTPUTS (nFAULT)						
V_{OL}	Output logic low voltage	$I_{OD} = 5$ mA	0		0.4	V
I_{OH}	Output logic high current	$V_{OD} = 5$ V	-1		1	μA
C_{OD}	Output capacitance				15	pF
PUSH-PULL OUTPUTS (SDO)						
V_{OL}	Output logic low voltage	$I_{OP} = 5$ mA	0		0.4	V
V_{OH}	Output logic high voltage	$I_{OP} = 5$ mA	$V_{DD} - 0.6$		V_{DD}	V
I_{OL}	Output logic low current	$V_{OP} = 0$ V	-1		1	μA
I_{OH}	Output logic high current	$V_{OP} = V_{VDD}$	-1		1	μA
C_{OD}	Output capacitance				30	pF
DRIVER OUTPUTS (OUTx)						
$R_{DS(ON)}$	High-side MOSFET on resistance	$V_{VM} = 13.5$ V, $I_{OUT} = 0.5$ A, $T_A = 25^{\circ}\text{C}$		0.75	1.1	Ω
		$V_{VM} = 13.5$ V, $I_{OUT} = 0.5$ A, $T_A = 125^{\circ}\text{C}$			1.5	Ω
	Low-side MOSFET on resistance	$V_{VM} = 13.5$ V, $I_{OUT} = 0.5$ A, $T_A = 25^{\circ}\text{C}$		0.75	1.1	Ω
		$V_{VM} = 13.5$ V, $I_{OUT} = 0.5$ A, $T_A = 125^{\circ}\text{C}$			1.5	Ω
SR	Output rise and fall time (high-side and low-side)	$V_{VM} = 13.5$ V, 10-90%, $R_{LOAD} = 27$ Ω , $HBx_SR = 0b$		0.6		V/ μs
		$V_{VM} = 13.5$ V, 10-90%, $R_{LOAD} = 27$ Ω , $HBx_SR = 1b$		2.5		V/ μs
t_{DEAD}	Output dead time (high to low / low to high)	$V_{VM} = 13.5$ V, SR = 0, HS/LS driver OFF to LS/HS driver ON	8	20	32	μs
		$V_{VM} = 13.5$ V, SR = 1, HS/LS driver OFF to LS/HS driver ON	2	5	15	μs
t_{PD}	Propagation delay (high-side / low-side ON/OFF)	High-side ON or low-side ON command (SPI last transition) to OUTx transition from Hi-Z state, SR = 0	5	12	25	μs
		High-side ON or low-side ON command (SPI last transition) to OUTx transition from Hi-Z state, SR = 1	3	5	10	μs
I_{LEAK}	Leakage current low-side	$V_{OUTx} = 13.5$ V, nSLEEP = 1, SR = 0b		6	10	μA
		$V_{OUTx} = 13.5$ V, nSLEEP = 1, SR = 1b		20	35	μA
		$V_{OUTx} = 13.5$ V, nSLEEP = 0		4	15	μA
	Leakage current high-side	$V_{OUTx} = 0$ V, nSLEEP = 1			2	μA
$V_{OUTx} = 0$ V, nSLEEP = 0				2	μA	
PWM MODE						
f_{PWM}	PWM switching frequency	PWM_CHx_FREQ = 00b	56	80	104	Hz
		PWM_CHx_FREQ = 01b	70	100	130	Hz
		PWM_CHx_FREQ = 10b	140	200	260	Hz
		PWM_CHx_FREQ = 11b	1400	2000	2600	Hz
PROTECTION CIRCUITS						
V_{UVLO}	Supply undervoltage lockout (UVLO)	Supply rising	4.0		4.5	V
		Supply falling	3.8		4.3	V
V_{UVLO_HYS}	Supply undervoltage lockout hysteresis	Rising to falling threshold		200		mV
t_{UVLO}	Supply undervoltage deglitch time			10		μs

Electrical Characteristics (continued)

at $T_J = -40^{\circ}\text{C}$ to $+150^{\circ}\text{C}$, $V_{VM} = 4.5$ to 32 V (Main Supply), $V_{VDD} = 3$ to 5.5 V (Logic Supply) (unless otherwise noted). Typical limits apply for $T_A = 25^{\circ}\text{C}$, $V_{VM} = 13.5$ V, $V_{VDD} = 3.3$ V

PARAMETER		TEST CONDITIONS	MIN	TYP	MAX	UNIT
V_{OVP}	Supply overvoltage protection (OVP)	Supply rising, EXT_OVP = 0b	21		25	V
		Supply falling, EXT_OVP = 0b	20		24	V
		Supply rising, EXT_OVP = 1b	32.7		35	V
		Supply falling, EXT_OVP = 1b	32		34.3	V
V_{OVP_HYS}	Supply overvoltage protection hysteresis	Rising to falling threshold, EXT_OVP = 0b		1		V
		Rising to falling threshold, EXT_OVP = 1b		0.7		V
t_{OVP}	Supply overvoltage deglitch time		10			μs
V_{POR}	Logic undervoltage (POR)	Supply rising	2.45		3	V
		Supply falling	2.4		2.95	V
V_{POR_HYS}	Logic undervoltage hysteresis	Rising to falling threshold		75		mV
I_{OCP}	Overcurrent protection trip point ⁽¹⁾⁽²⁾		1.3	1.8	2.3	A
t_{OCP}	Overcurrent protection deglitch time	OCP_DEG = 000b	6	10	14	μs
		OCP_DEG = 001b	2.6	5	7.9	μs
		OCP_DEG = 010b	0.4	2.5	5.9	μs
		OCP_DEG = 011b	0.1	1	3.4	μs
		OCP_DEG = 100b	38.2	60	76.6	μs
		OCP_DEG = 101b	23.1	40	51.9	μs
		OCP_DEG = 110b	18.5	30	41.5	μs
OCP_DEG = 111b	8.4	20	31.6	μs		
I_{OLD}	Open load detection current	Current flowing from VM to OUTx (High-Side = ON) or OUTx to GND (Low-Side = ON)	2	9	18	mA
I_{OLD_NEG}	Negative open load detection current	Current flowing from OUTx to VM (High-Side = ON) or GND to OUTx (Low-Side = ON)	2	15	30	mA
I_{OLD_LOW}	Open load detection current in low current OLD mode	Current flowing from VM to OUTx (High-Side = ON) or OUTx to GND (Low-Side = ON)	0.2	0.8	2	mA
I_{OL_GND}	Passive OLD current	DRV8908/6/4, FETs in Hi-Z state, current from OUTx to GND during OLD trip		113		μA
V_{OL_GND}	Passive OLD voltage threshold	DRV8908/6/4, FETs in Hi-Z state, voltage at OUTx during OLD trip for GND-connected load		3.3		V
I_{OL_VM}	Passive OLD current	DRV8908/6/4, FETs in Hi-Z state, current from VM to OUTx for OLD trip, HBX_VM_POLD = 0b		118		μA
V_{OL_VM}	Passive OLD voltage threshold	DRV8908/6/4, FETs in Hi-Z state, voltage at OUTx during OLD trip for VM-connected load, HBX_VM_POLD = 0b		1.2		V
I_{OL_VM}	Passive OLD current	DRV8908/6/4, FETs in Hi-Z state, current from VM to OUTx for OLD trip, HBX_VM_POLD = 1b		547		μA
V_{OL_VM}	Passive OLD voltage threshold	DRV8908/6/4, FETs in Hi-Z state, voltage at OUTx during OLD trip for VM connected load, HBX_VM_POLD = 1b		1.8		V

(1) For $20\text{-V} < V_{VM} < 28\text{-V}$, the OCP deglitch time must be limited to $10\text{-}\mu\text{s}$ (Default Deglitch Value, OCP_DEG = 000b).

(2) For $V_{VM} > 28$ V, the OCP deglitch time must be limited to $1\text{-}\mu\text{s}$ (Lowest Deglitch Value, OCP_DEG = 011b).

Electrical Characteristics (continued)

at $T_J = -40^{\circ}\text{C}$ to $+150^{\circ}\text{C}$, $V_{VM} = 4.5$ to 32 V (Main Supply), $V_{VDD} = 3$ to 5.5 V (Logic Supply) (unless otherwise noted). Typical limits apply for $T_A = 25^{\circ}\text{C}$, $V_{VM} = 13.5$ V, $V_{VDD} = 3.3$ V

PARAMETER		TEST CONDITIONS	MIN	TYP	MAX	UNIT
R_{OL}	Passive OLD detect resistance threshold	DRV8908/6/4, FETs in Hi-Z state, Full bridge connection	5		100	k Ω
R_{OL}	Passive OLD detect resistance threshold	DRV8908/6/4, FETs in Hi-Z State, Load connected to GND	5		100	k Ω
R_{OL}	Passive OLD detect resistance threshold	DRV8908/6/4, FETs in Hi-Z State, Load connected to VM, HBX_VM_POLD = 0b	5		400	k Ω
R_{OL}	Passive OLD detect resistance threshold	DRV8908/6/4, FETs in Hi-Z State, Load connected to VM, HBX_VM_POLD = 1b	5		100	k Ω
t_{OLD}	Open load deglitch time	Active OLD (Continuous Mode)	2	3	4	ms
t_{OLD}	Open load deglitch time	Active OLD (PWM Mode)	150	200	300	μs
T_{OTW}	Thermal warning temperature	Die temperature (T_j)	120	140	170	$^{\circ}\text{C}$
T_{OTW_HYS}	Thermal warning hysteresis	Die temperature (T_j)		20		$^{\circ}\text{C}$
T_{OTSD}	Thermal shutdown temperature	Die temperature (T_j)	150	175	200	$^{\circ}\text{C}$
T_{OTSD_HYS}	Thermal shutdown hysteresis	Die temperature (T_j)		20		$^{\circ}\text{C}$

7.6 Timing Requirements

PARAMETER		TEST CONDITIONS	MIN	NOM	MAX	UNIT
SPI (nSCS, SCLK, SDI, SDO)						
t_{READY}	SPI ready after enable	VM > UVLO, ENABLE = 3.3 V			1	ms
t_{CLK}	SCLK minimum period		200			ns
t_{CLKH}	SCLK minimum high time		100			ns
t_{CLKL}	SCLK minimum low time		100			ns
t_{SU_SDI}	SDI input data setup time		40			ns
t_{HD_SDI}	SDI input data hold time		60			ns
t_{DLY_SDO}	SDO output data delay time	SCLK high to SDO valid			60	ns
t_{SU_nSCS}	nSCS input setup time		100			ns
t_{HD_nSCS}	nSCS input hold time		100			ns
t_{HI_nSCS}	nSCS minimum high time before active low		600			ns
t_{DIS_nSCS}	nSCS disable delay time	nSCS high to SDO high impedance		30		ns
t_{SC_SPI}	Successive SPI write gaps			2.5		μs

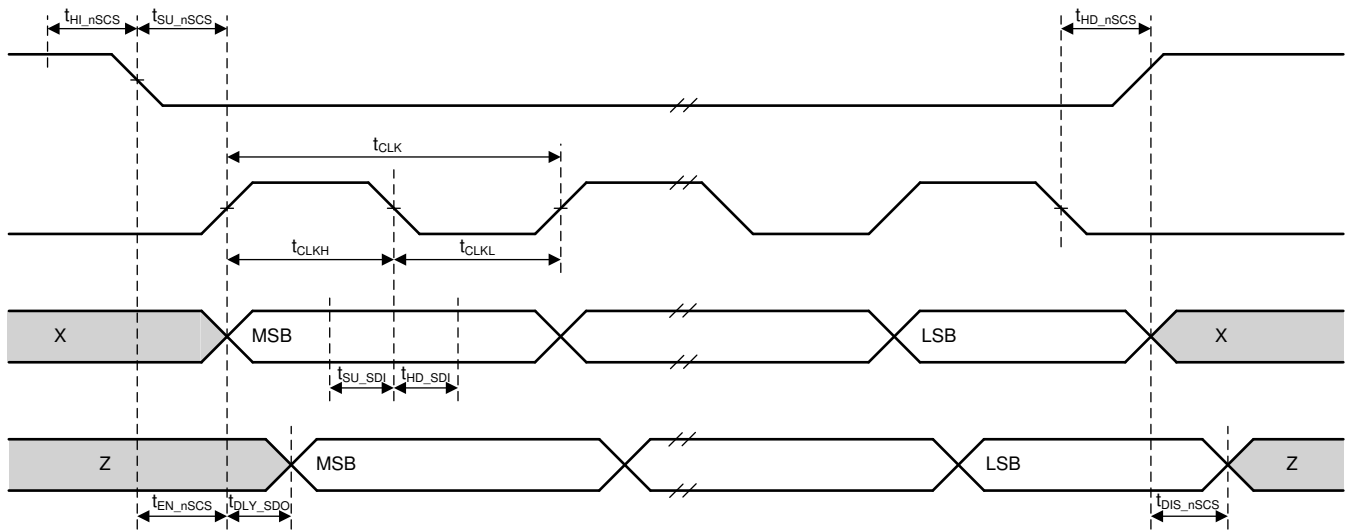
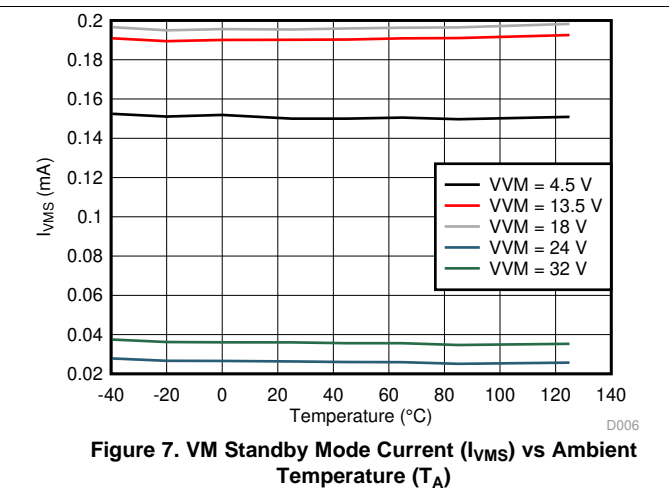
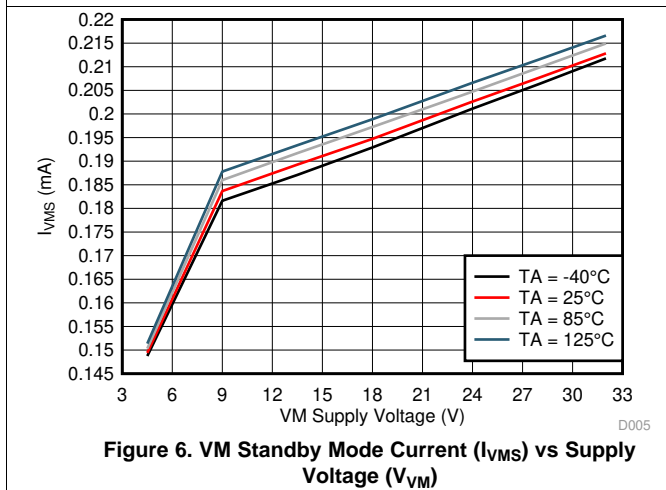
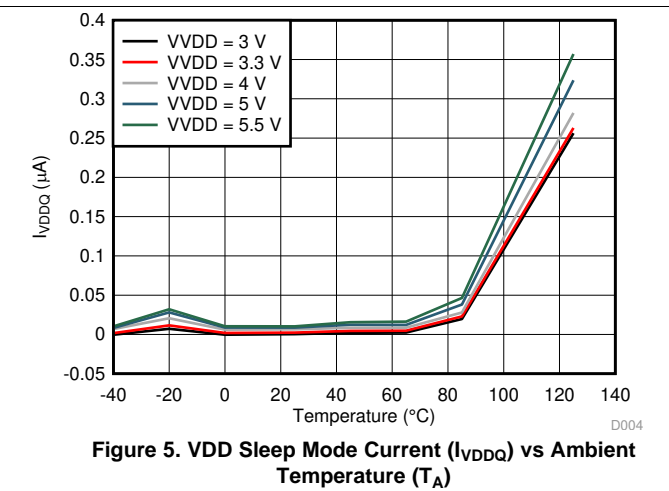
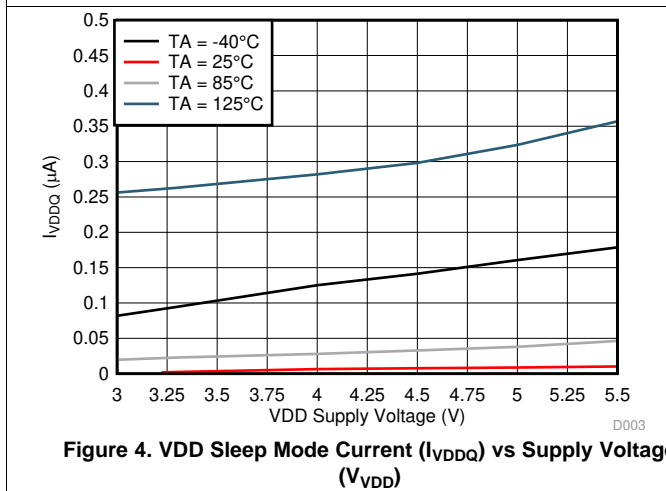
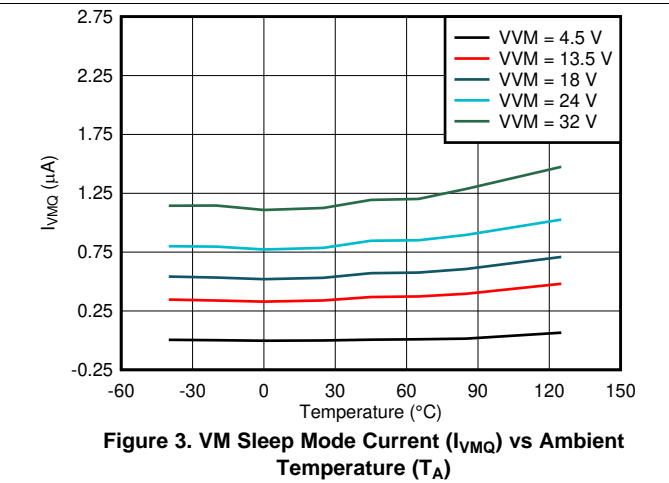
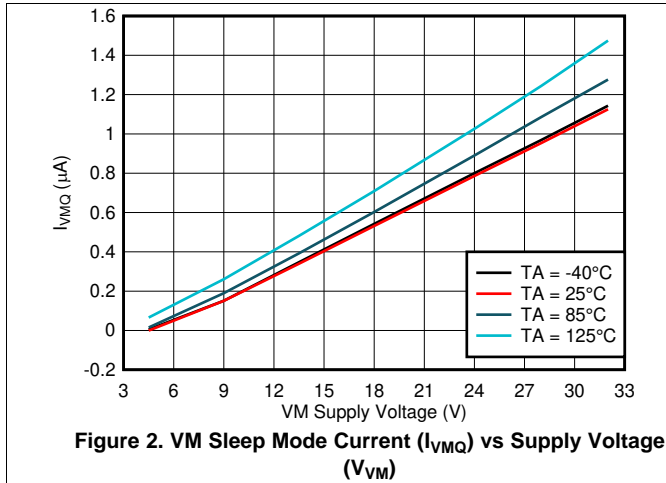

Figure 1. SPI Timing

7.7 Typical Characteristics



Typical Characteristics (continued)

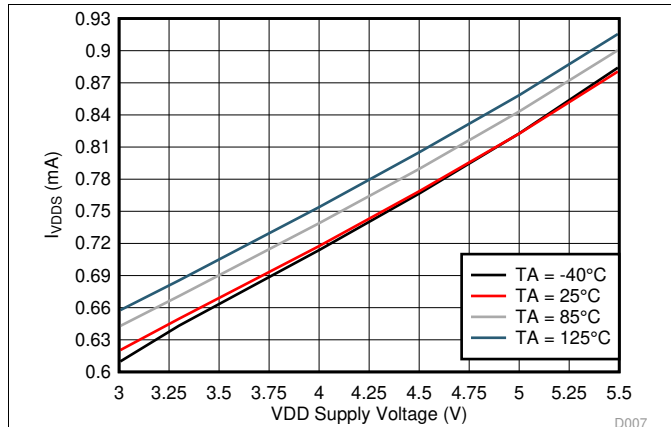

Figure 8. VDD Standby Mode Current (I_{VDD_S}) vs Supply Voltage (V_{VDD})

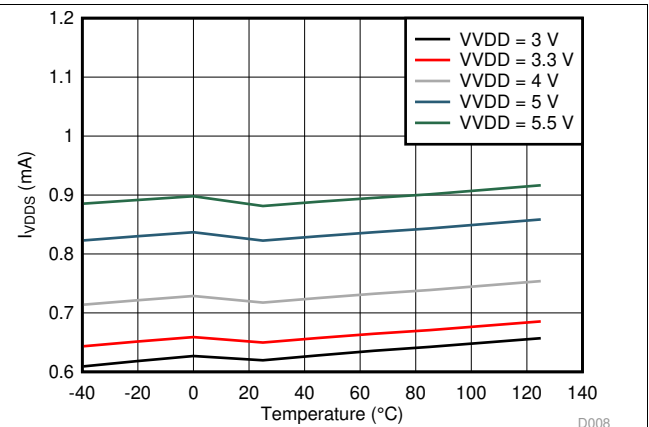

Figure 9. VDD Standby Mode Current (I_{VDD_S}) vs Ambient Temperature (T_A)

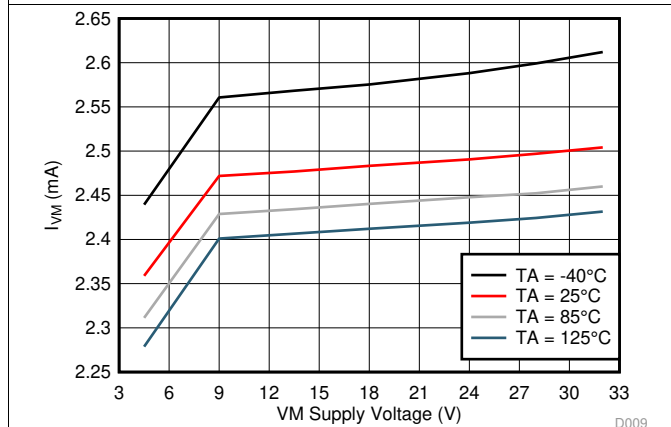

Figure 10. VM Operating Mode Current (I_{VM}) vs Supply Voltage (V_{VM})

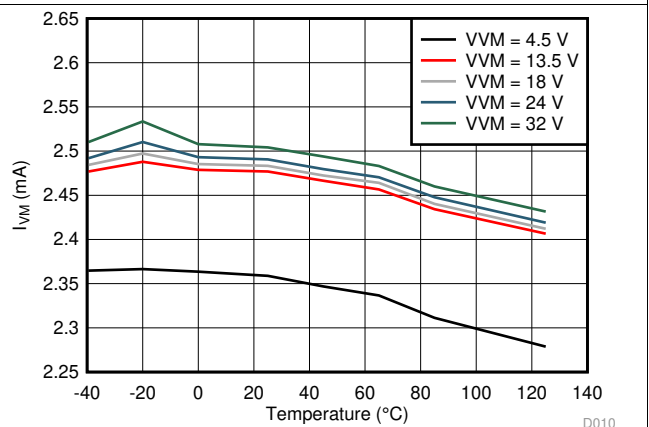

Figure 11. VM Operating Mode Current (I_{VM}) vs Ambient Temperature (T_A)

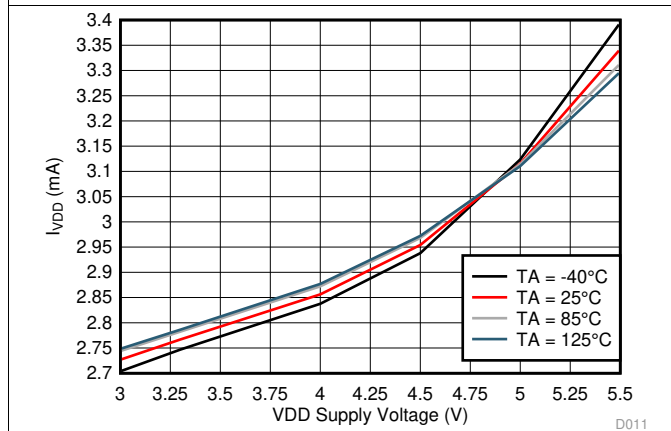

Figure 12. VDD Operating Mode Current (I_{VDD_O}) vs Supply Voltage (V_{VDD})

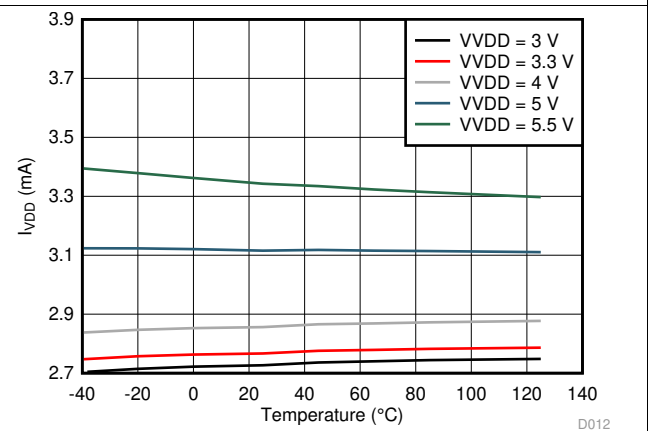

Figure 13. VDD Operating Mode Current (I_{VDD_O}) vs Ambient Temperature (T_A)

Typical Characteristics (continued)

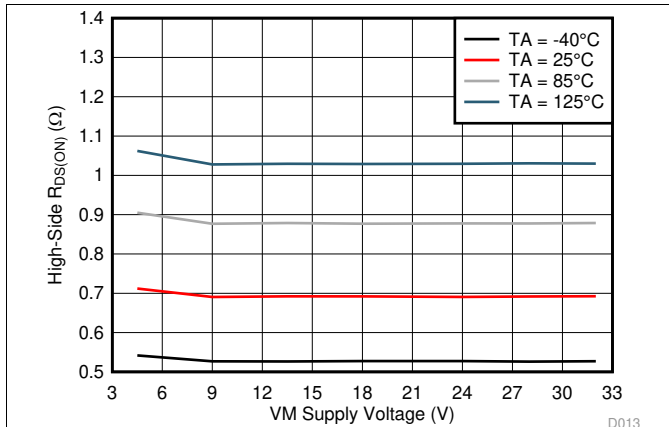

Figure 14. Figure 7. High Side On-State Resistance ($R_{DS(ON)}$) vs Supply Voltage (V_{VM})

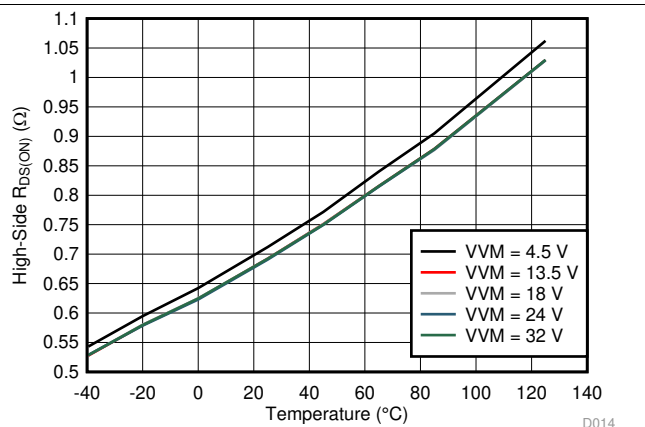

Figure 15. High Side On-State Resistance ($R_{DS(ON)}$) vs Ambient Temperature (T_A)

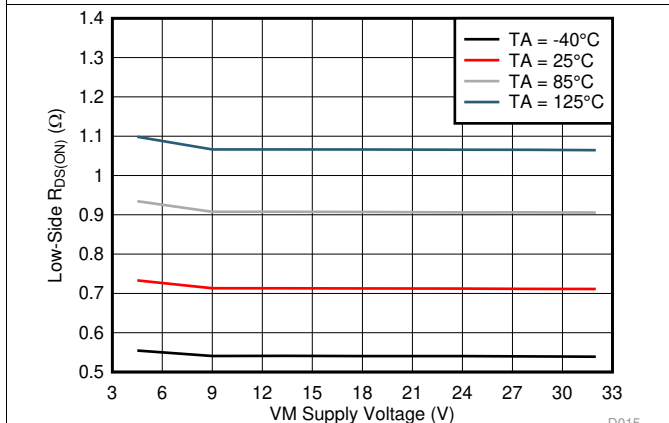

Figure 16. Low-Side On-State Resistance ($R_{DS(ON)}$) vs Supply Voltage (V_{VM})

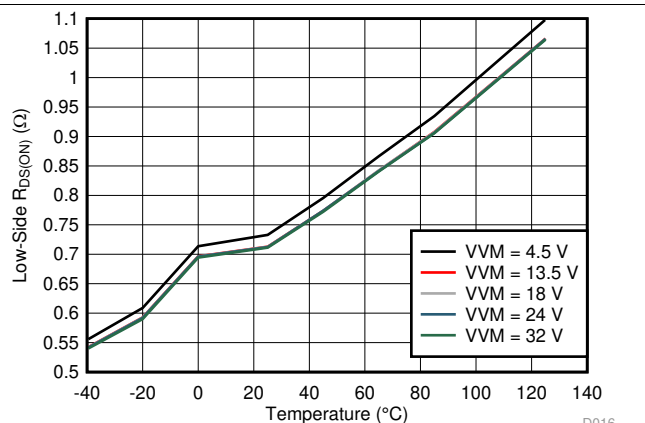

Figure 17. Low-Side On-State Resistance ($R_{DS(ON)}$) vs Ambient Temperature (T_A)

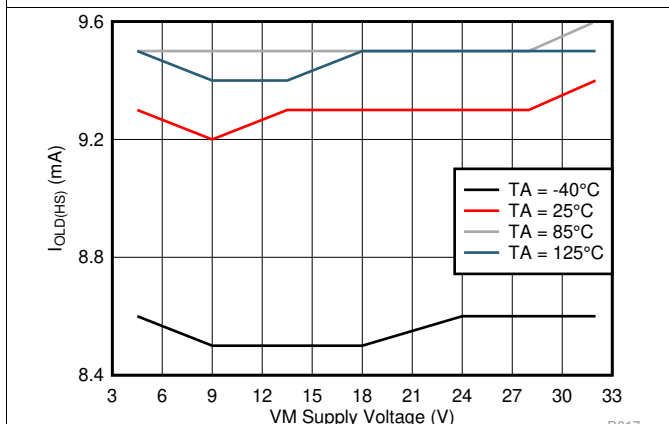

Figure 18. High-Side Open-Load Detection Current ($I_{OL(D)}$) vs Supply Voltage (V_{VM})

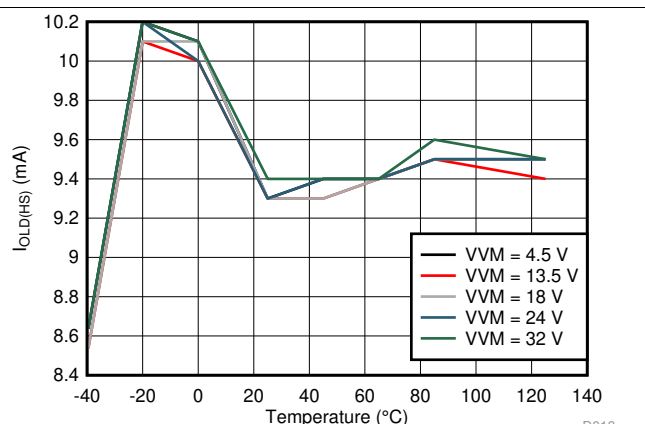

Figure 19. High-Side Open-load Detection Current ($I_{OL(D)}$) vs Ambient Temperature (T_A)

Typical Characteristics (continued)

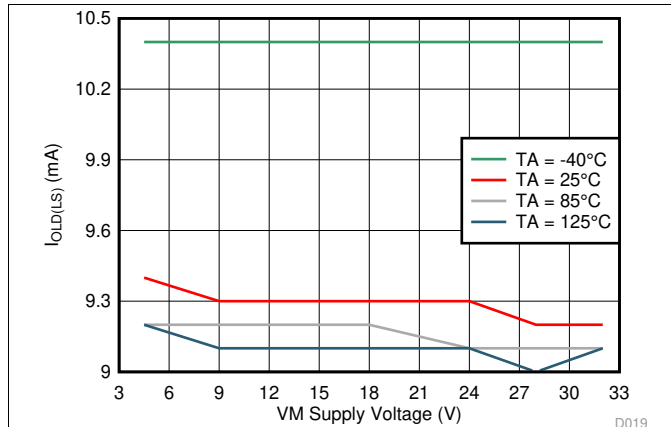

Figure 20. Low-Side Open-load Detection Current (I_{OLDS}) vs Supply Voltage (V_{VM})

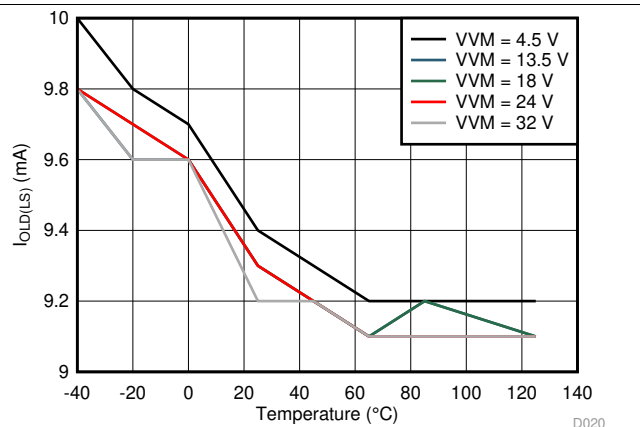

Figure 21. Low-Side Open-load Detection Current (I_{OLDS}) vs Ambient Temperature (T_A)

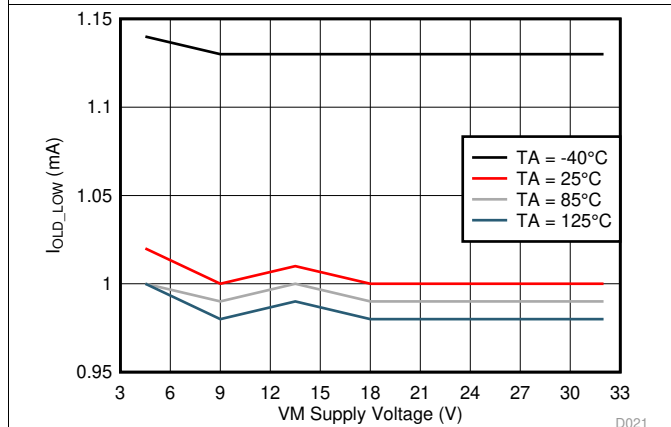

Figure 22. Low open-load detection current (I_{OLDS_LOW}) vs supply voltage (V_{VM})

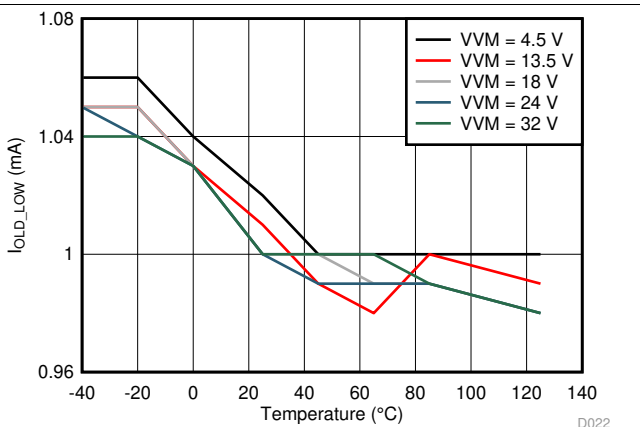

Figure 23. Low open-load detection current (I_{OLDS_LOW}) vs ambient temperature (T_A)

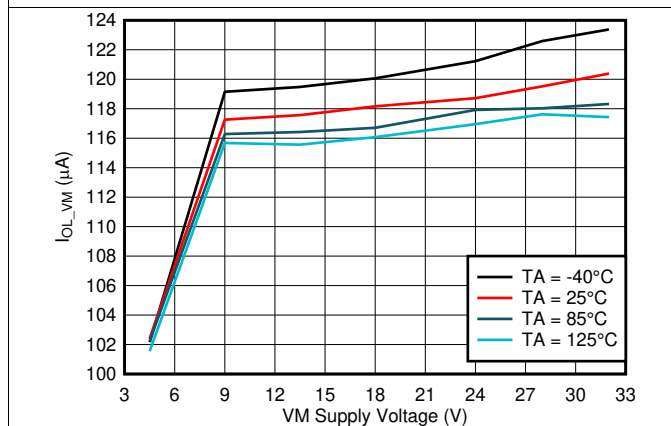

Figure 24. Open-load pull-down current (I_{OL_VM}) when $HBX_VM_POLD = 0b$ vs supply voltage (V_{VM})

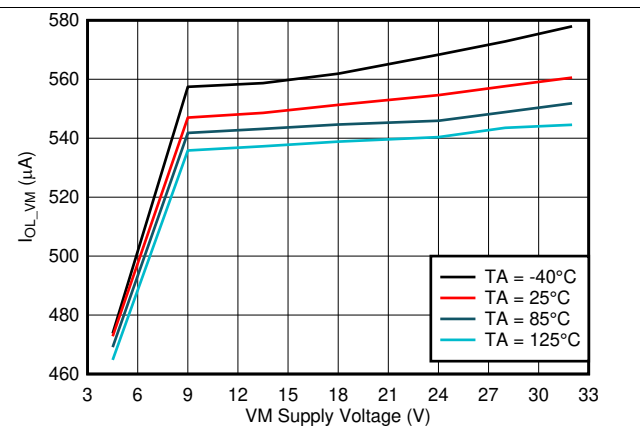

Figure 25. Open-load pull-down current (I_{OL_VM}) when $HBX_VM_POLD = 1b$ vs supply voltage (V_{VM})

Typical Characteristics (continued)

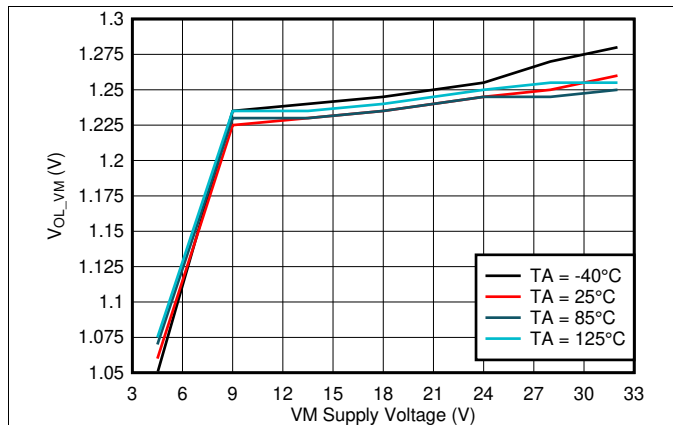

Figure 26. Open-load low-side threshold voltage (V_{OL_VM}) when $HBX_VM_POLD = 0b$ vs supply voltage (V_{VM})

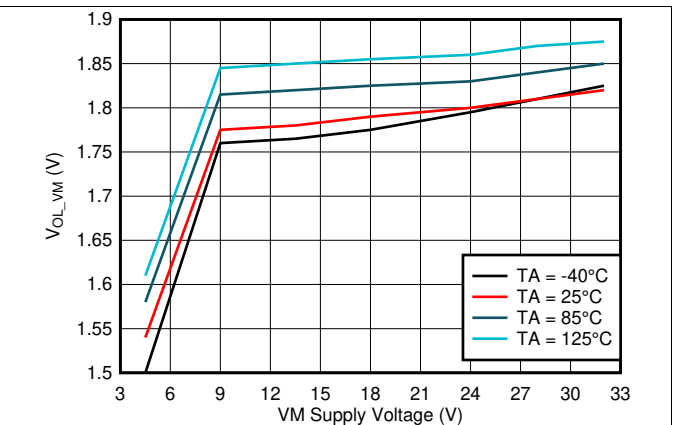

Figure 27. Open-load low-side threshold voltage (V_{OL_VM}) when $HBX_VM_POLD = 1b$ vs supply voltage (V_{VM})

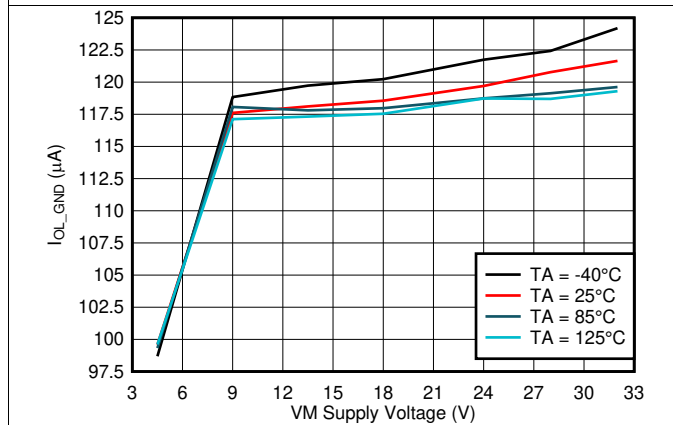

Figure 28. Open-load pull-up current (I_{OL_GND}) vs supply voltage (V_{VM})

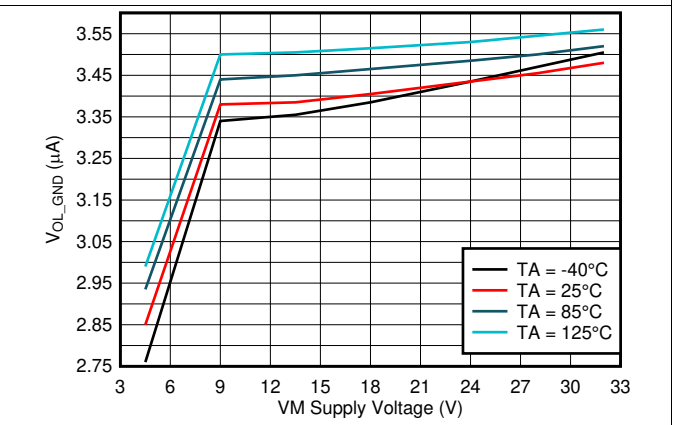

Figure 29. Open-load low-side threshold voltage (V_{OL_GND}) vs supply voltage (V_{VM})

8 Detailed Description

8.1 Overview

The DRV89xx-Q1 family are 4.5-V to 32-V integrated multi half-bridge drivers which supports a maximum voltage of 40-V for load-dump scenario. The half-bridges are designed to support 1-A per half-bridge and 6-A from the VM/GND pins. The DRV89xx family offers drivers from 4 to 12 half-bridge outputs.

A standard 16-bit, 5-MHz serial peripheral interface (SPI) provides a simple method for configuring the various device settings and reading fault diagnostic information through an external controller. The device is also equipped with a daisy-chain functionality which allows connecting multiple devices using a single nSCS line and saving on multiple resources.

This device has 4 internal PWM generators (DRV8912-Q1 and DRV8910-Q1) or 8 internal PWM generators (DRV8908-Q1, DRV8906-Q1 and DRV8904-Q1) which can be mapped to any of the half-bridge through SPI registers. The PWM frequency (4 options) and duty (8-bit resolution) for each channel can be selected using the SPI registers. This PWM mode is useful for implementing the current control of motor or dimming control of LEDs.

The device also has numerous integrated protection features which protects the device in case of any abnormal scenario. The over-current protection (OCP) ensures the device protection in any short scenarios like the phase short, phase to ground short and phase to supply short conditions. Undervoltage lockout (UVLO) and overvoltage protection (OVP) ensures the driver operation in fluctuating voltages to support the crank-start and load-dump scenario in automotive applications. In addition to this, the open-load detection (OLD) feature ensure the proper load connection. All devices support active OLD, low-current OLD, and negative-current OLD. Passive OLD is only supported on DRV8908-Q1, DRV8906-Q1 and DRV8904-Q1 devices. Device faults are indicated on the nFAULT pin, and detailed information is available in the device SPI registers.

The device integrates a spread spectrum clocking feature for both the internal digital oscillator and internal charge pump. This feature combined with programmable output slew-rate control minimizes the radiated emissions from the device.

The device is available in a 24-pin HTSSOP package with a thermal pad.

8.2 Functional Block Diagram

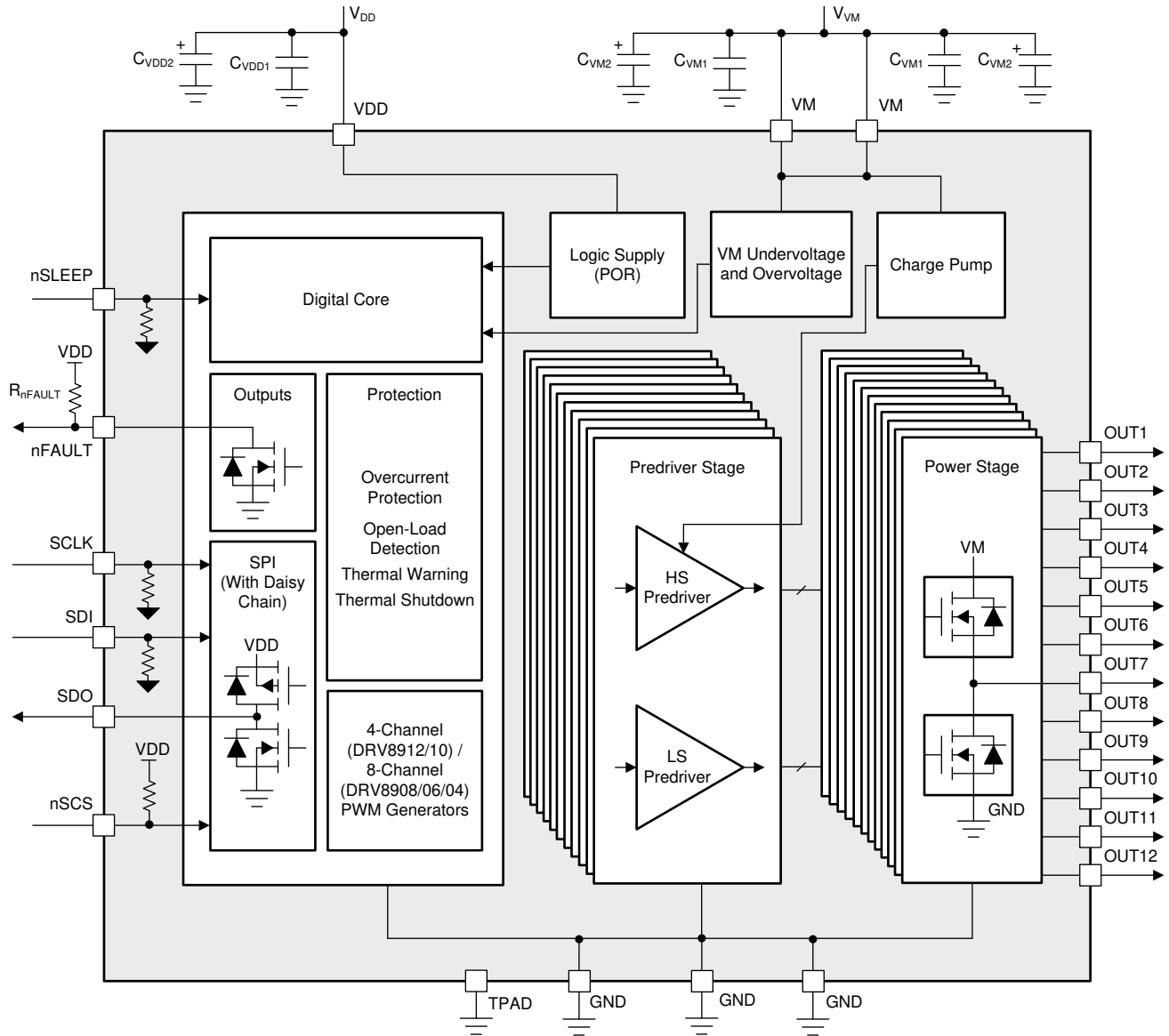

8.3 Feature Description

Table 1 lists the recommended values of the external components for the driver.

Table 1. DRV89xx-Q1 Driver External Components

COMPONENTS	PIN 1	PIN 2	RECOMMENDED
C _{VM1}	VM	GND	X5R or X7R, 0.1-μF, VM-rated capacitor
C _{VM2}	VM	GND	≥ 10 μF, VM-rated capacitor
C _{VDD1}	VDD	GND	X5R or X7R, 0.1-μF, 6.3-V capacitor
C _{VDD2}	VDD	GND	≥ 1 μF, 6.3-V capacitor
R _{nFAULT}	VDD	nFAULT	Pullup resistor

8.3.1 Half Bridge Drivers

8.3.1.1 Control Modes

The half-bridge drivers can be programmed to drive loads (motor, solenoids, LEDs) continuously (without PWM) or in chopping mode (with PWM) and in parallel operation for driving high current.

8.3.1.1.1 Continuous Mode (Without PWM)

The half-bridges are configured to operate in the continuous mode without using any PWM switching by default. Any high-side or low-side switch is switched on by individually setting the high-side enable bits (HBX_HS_EN) and low-side enable bits (HBX_LS_EN) in operation control registers (OP_CTRL_1, OP_CTRL_2 and OP_CTRL_3).

NOTE

If the high-side enable bit (HBX_HS_EN) and low-side enable bit (HBX_LS_EN) of a particular half-bridge is set high (shoot-through configuration), then the particular half-bridge driver will remain in Hi-Z state until the shoot-through condition is cleared.

The high-side and low-side enable bits of a particular half-bridge are configured to drive the motor in forward mode, reverse mode, brake mode and coast mode as shown in Table 2.

Table 2. Motor Operation in Continuous Mode (Motor Connected between HB1 and HB2)

nSLEEP	HALF-BRIDGE-1	HALF-BRIDGE-2	OUT1	OUT2	BRIDGE OPERATION (DC MOTOR)
0	HB1_HS_EN = Don't Care HB1_LS_EN = Don't Care	HB2_HS_EN = Don't Care HB2_LS_EN = Don't Care	Z	Z	Sleep Mode
1	HB1_HS_EN = 0 HB1_LS_EN = 0	HB2_HS_EN = 0 HB2_LS_EN = 0	Z	Z	Motor Coast
1	HB1_HS_EN = 1 HB1_LS_EN = 0	HB2_HS_EN = 0 HB2_LS_EN = 1	H	L	Forward Direction
1	HB1_HS_EN = 0 HB1_LS_EN = 1	HB2_HS_EN = 1 HB2_LS_EN = 0	L	H	Reverse Direction
1	HB1_HS_EN = 0 HB1_LS_EN = 1	HB2_HS_EN = 0 HB2_LS_EN = 1	L	L	Motor Brake (Low-Side)
1	HB1_HS_EN = 1 HB1_LS_EN = 0	HB2_HS_EN = 1 HB2_LS_EN = 0	H	H	Motor Brake (High-Side)
1	HB1_HS_EN = 1 HB1_LS_EN = 1	HB2_HS_EN = 1 HB2_LS_EN = 1	Z	Z	Motor Coast

Figure 30 shows the bridge configuration for motor operation in forward direction with high-side FET of OUT1 and low-side FET of OUT2 in conducting state with current flowing from OUT1 to OUT2. Similarly, the motor operation in reverse direction is achieved by switching ON the high-side FET of OUT2 and low-side FET of OUT1 such that current flows from OUT2 to OUT1 as shown in Figure 31.

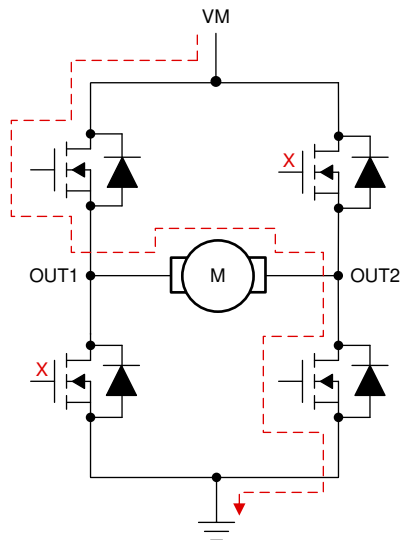

Figure 30. Continuous Mode (Forward Direction)

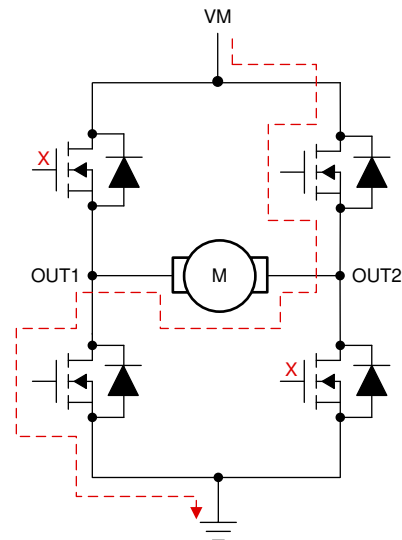

Figure 31. Continuous Mode (Reverse Direction)

Figure 32 and Figure 33 shows the bridge operation in coast mode with motor initially running in forward and reverse direction respectively. As shown in these figures, due to the energy stored in motor's inductance, the current will continue to flow in motor and take the path flow through the body diodes of FETs.

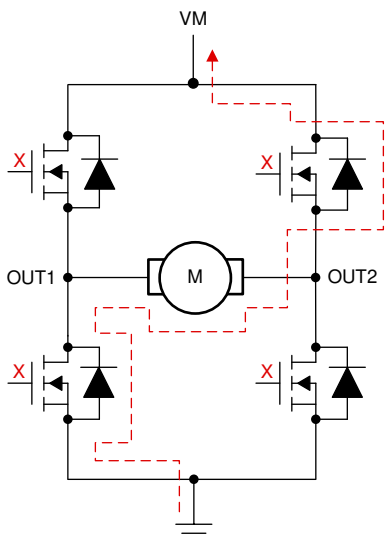

Figure 32. Continuous Mode (Coast - From Forward Direction)

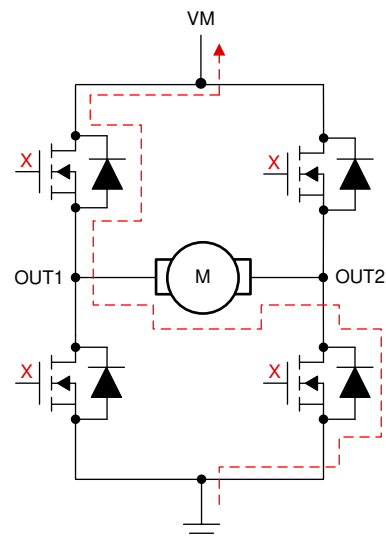

Figure 33. Continuous Mode (Coast- From Reverse Direction)

Figure 34 shows the low-side braking of the motor when both low-side FET's of the driver are turned ON. In this case, the motor is considered to be operating in forward direction (current flow from OUT1 to OUT2) and then braking is applied. Similarly, for the high-side braking, both high-side FET's of the driver are turned ON as shown in Figure 35.

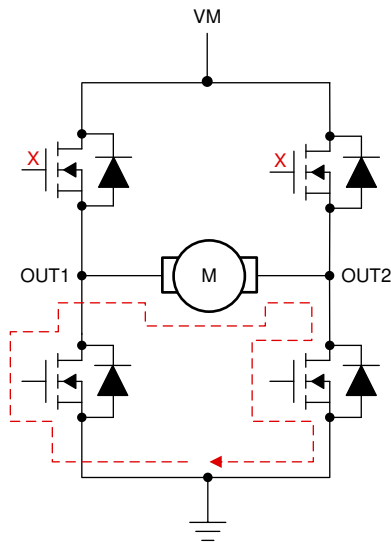

Figure 34. Continuous Mode (Brake - Low-Side)

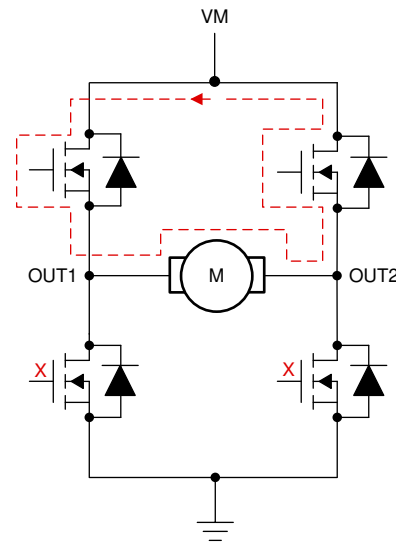

Figure 35. Continuous Mode (Brake - High-Side)

8.3.1.1.2 Chopping Mode (With PWM)

The half-bridges can be configured in the chopping mode by enabling the PWM switching on any particular half-bridge or both half-bridges. Each half-bridge can be mapped to any of the 4 PWM channels for which frequency and duty can be controlled independently. User has the flexibility to select the PWM frequency of channels out of 4 settings of 80-Hz, 100-Hz, 200-Hz and 2-kHz. Moreover, duty (8-bit resolution) of the 4 PWM generators can be adjusted independently.

The PWM chopping mode operation is done in five steps as follows and explained in detail below.

1. PWM Configuration
2. Free-Wheeling Mode (Synchronous Rectification) Disable / Enable
3. PWM Channels Mapping
4. PWM Channels Configuration (PWM Frequency and PWM Duty)
5. Half-Bridge Enable

8.3.1.1.2.1 PWM Configuration

The operation of selected half-bridge to operate in continuous mode or chopping mode (PWM mode) is selected using the PWM control register (PWM_CTRL_1 and PWM_CTRL_2). The HBX_PWM bit in PWM control register is set to enable the PWM switching in half-bridge.

NOTE

The default mode of any half-bridge is continuous mode. If the corresponding HBx_PWM bit in PWM_CTRL_X register is not set, then the particular half-bridge will operate in continuous mode.

8.3.1.1.2.2 Free-Wheeling Mode (Synchronous Rectification) Disable / Enable

The synchronous rectification of the half-bridge operating in PWM can be enabled by setting the HBx_FW bit in free-wheeling control registers (FW_CTRL_1 and FW_CTRL_2). Figure 36 shows the operation of the driver when the synchronous rectification mode is disabled. As shown in this figure, during the PWM off time, the high-side diode of the OUT2 conducts to close the current path required for motor.

When synchronous rectification mode is enabled, if either of the low-side or high-side of the half-bridge operates in the PWM switching, then the other switch of the same half-bridge operates in complementary fashion. Figure 37 shows such example of the synchronous rectification, where the high-side FET of OUT2 half-bridge is turned ON when the low-side FET of same half-bridge is turned off in a PWM cycle.

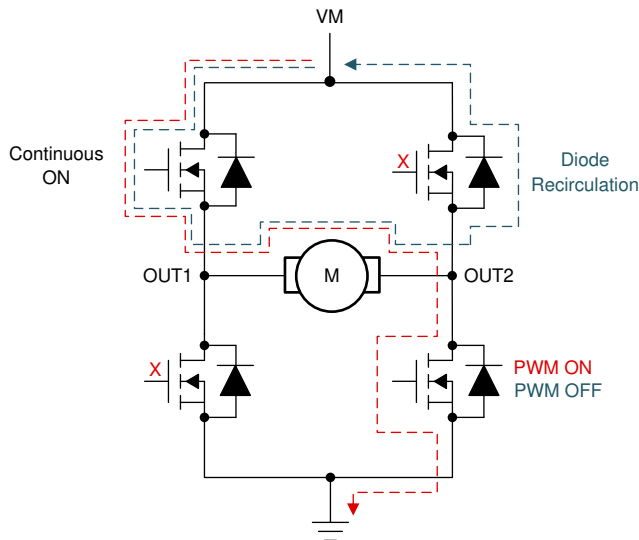

Figure 36. PWM Mode (Synchronous Rectification = OFF)

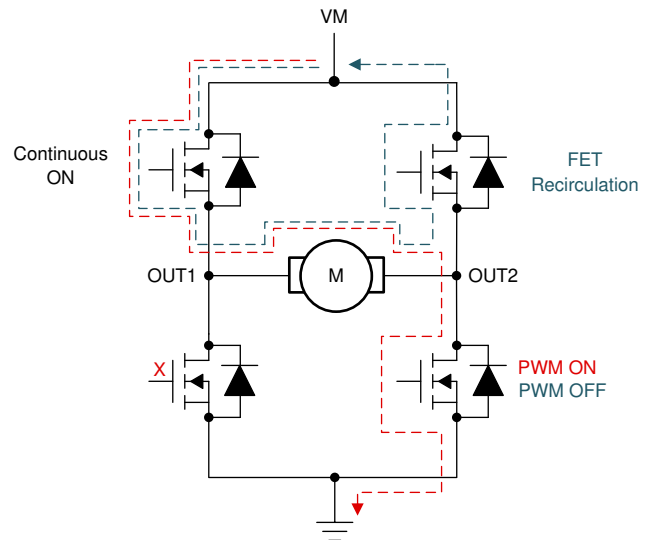

Figure 37. PWM Mode (Synchronous Rectification = ON)

NOTE

The default mode of any half-bridge is asynchronous rectification mode. If the corresponding bit in FW_CTRL_X register is not set, then the particular half-bridge will operate in asynchronous rectification mode.

8.3.1.1.2.3 PWM Channels Mapping

DRV89XX-Q1 devices includes 4/8 PWM generators which can be mapped to any of the OUTX half bridge outputs using the PWM map control registers. The HBx_PWM_MAP bits in the PWM_MAP_CTRL_X registers are used to map any of the 4 channels in DRV8912-Q1/DRV8910-Q1 or 8 channels in DRV8908-Q1/DRV8906-Q1/DRV8904-Q1 to the OUTX outputs as shown in Table 3.

Table 3. PWM Mapping of DRV8912-Q1/DRV8910-Q1

HBX_PWM_MAP BITS	PWM CHANNEL
HBX_PWM_MAP = 00b	Channel 1 Selected for OUTX
HBX_PWM_MAP = 01b	Channel 2 Selected for OUTX
HBX_PWM_MAP = 10b	Channel 3 Selected for OUTX
HBX_PWM_MAP = 11b	Channel 4 Selected for OUTX

NOTE

Any half-bridge is mapped to PWM channel 1 by default.

8.3.1.1.2.4 PWM Channels Configuration (PWM Frequency and PWM Duty)

The frequency and duty of each PWM generator can be controlled independently. The PWM_CHx_FREQ bits of PWM frequency control register (PWM_FREQ_CTRL) is used to select the frequency of PWM generator as shown in Table 4. The PWM duty of each channel is controlled by the PWM duty control register (PWM_DUTY_CTRL_X).

Table 4. PWM Frequency

HBX_PWM MAP BITS	PWM CHANNEL
PWM_CHx_FREQ = 00b	80 Hz
PWM_CHx_FREQ = 01b	100 Hz
PWM_CHx_FREQ = 10b	200 Hz
PWM_CHx_FREQ = 11b	2000 Hz

8.3.1.1.2.5 Half-Bridge Enable

The four steps of PWM mode enable, free-wheeling mode configuration, PWM channel mapping and PWM channels configuration ensure the proper configuration of PWM mode. Once the half-bridge is configured for the PWM generation, the half-bridge is enabled by enabling either of the high-side or low-side switch by individually setting the high-side enable bits (HBX_HS_EN) or low-side enable bits (HBX_LS_EN) in operation control registers (OP_CTRL_1, OP_CTRL_2 and OP_CTRL_3).

NOTE

The PWM is applicable to either of the high-side or low-side switch depending upon the HBX_HS_EN and HBX_LS_EN bits in OP_CTRL_X registers. In synchronous rectification mode, the opposite side switch will conduct in PWM off time.

8.3.1.1.3 Parallel Mode (Continuous Operation)

Parallel mode in DRV89XX-Q1 device is implemented to support higher current loads which cannot be supported by a single channel. This mode can also be used for reducing the effective on-state resistance ($R_{DS(ON)}$) for achieving a better thermal performance of the device.

The configuration of various mode is very similar to the single half-bridge operation as explained in [Continuous Mode \(Without PWM\)](#) section. Considering six half-bridges for the parallel operation (OUT1, OUT2, OUT3 as group -

'X' and OUT4, OUT5, OUT6 as group 'Y'), various modes can be summarized in [Table 5](#).

Table 5. Motor Operation in Parallel Mode (Continuous Operation) (with Motor Connected between OUT1/2/3 and OUT4/5/6)

nSLEEP	HALF-BRIDGE-1 HALF-BRIDGE-2 HALF-BRIDGE-3 (X)	HALF-BRIDGE-4 HALF-BRIDGE-5 HALF-BRIDGE-6 (Y)	OUT1 OUT2 OUT3	OUT4 OUT5 OUT6	BRIDGE OPERATION (DC MOTOR)
0	HBX_HS_EN = Don't Care HBX_LS_EN = Don't Care	HBX_HS_EN = Don't Care HBX_LS_EN = Don't Care	Z	Z	Sleep Mode
1	HBX_HS_EN = 0 HBX_LS_EN = 0	HBX_HS_EN = 0 HBX_LS_EN = 0	Z	Z	Motor Coast
1	HBX_HS_EN = 1 HBX_LS_EN = 0	HBX_HS_EN = 0 HBX_LS_EN = 1	H	L	Forward Direction
1	HBX_HS_EN = 0 HBX_LS_EN = 1	HBX_HS_EN = 1 HBX_LS_EN = 0	L	H	Reverse Direction
1	HBX_HS_EN = 0 HBX_LS_EN = 1	HBX_HS_EN = 0 HBX_LS_EN = 1	L	L	Motor Brake (Low-Side)
1	HBX_HS_EN = 1 HBX_LS_EN = 0	HBX_HS_EN = 1 HBX_LS_EN = 0	H	H	Motor Brake (High-Side)
1	HBX_HS_EN = 1 HBX_LS_EN = 1	HBX_HS_EN = 1 HBX_LS_EN = 1	Z	Z	Motor Coast

NOTE

For parallel mode operation, the device operation under safe operating area (SOA) is recommended for supply voltage, $V_{VM} \leq 20\text{-V}$, $HBX_SR = HBX_SR = 1\text{b}$, $t_{OCP} \leq 10\text{-}\mu\text{s}$ and $PL_MODE_EN = 01\text{b}$.

Figure 38 shows three half-bridges (OUT1, OUT2 and OUT3) operating as a parallel high-side switch and other three half-bridges (OUT4, OUT5 and OUT6) are operating as a parallel low-side switch for achieving a forward motor operation. Similarly the reverse direction of motor is achieved by operation of OUT1, OUT2 and OUT3 as a parallel low-side switch and other three half-bridges (OUT4, OUT5 and OUT6) as parallel high-side switch as shown in Figure 39.

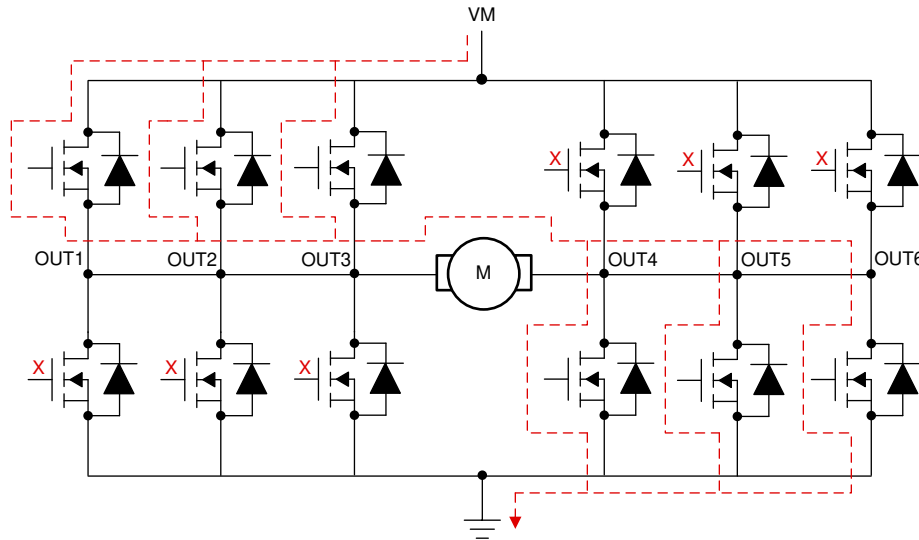

Figure 38. Parallel Mode (Forward Direction)

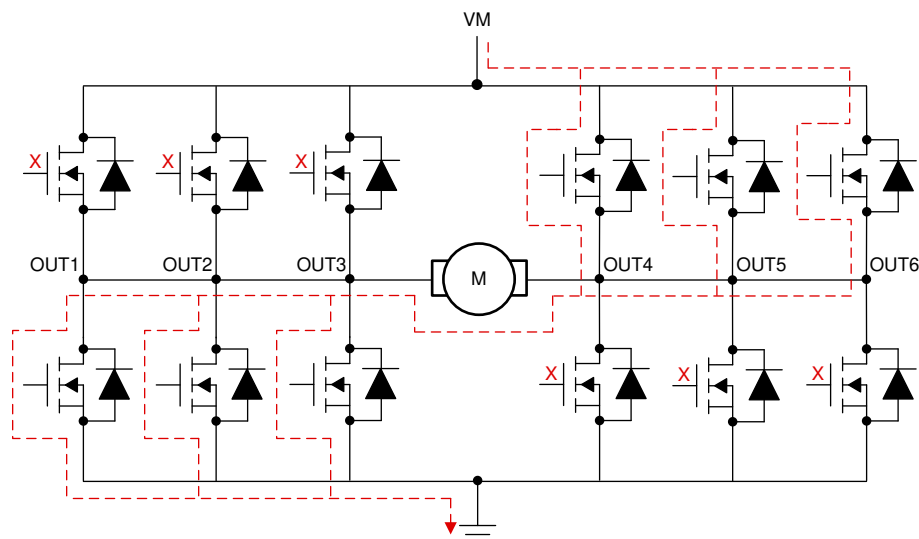

Figure 39. Parallel Mode (Reverse Direction)

Figure 40 and Figure 41 shows the bridge operation in coast mode with motor initially running in forward and reverse direction respectively. As shown in these figures, the body diodes of the FETs conducts to continue the current flow path due to energy stored in motor's inductance.

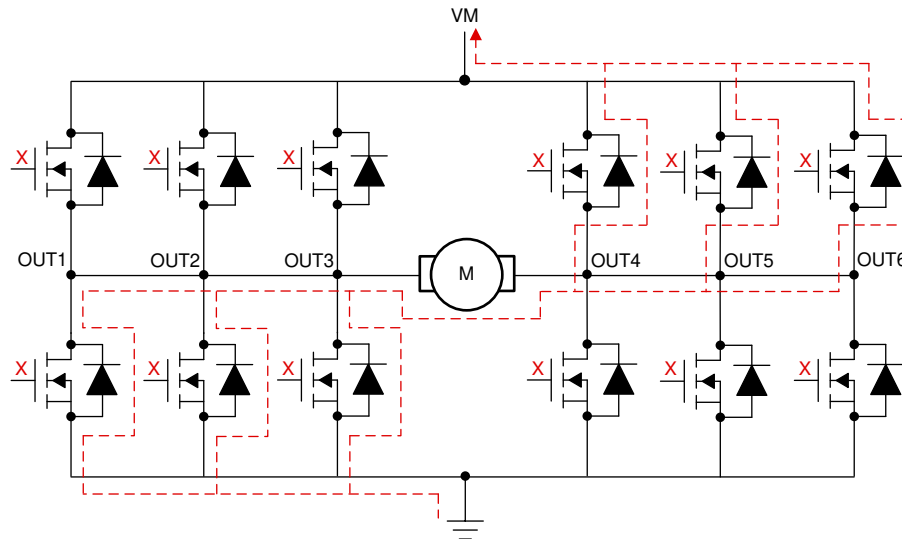

Figure 40. Parallel Mode (Coast from Forward Direction)

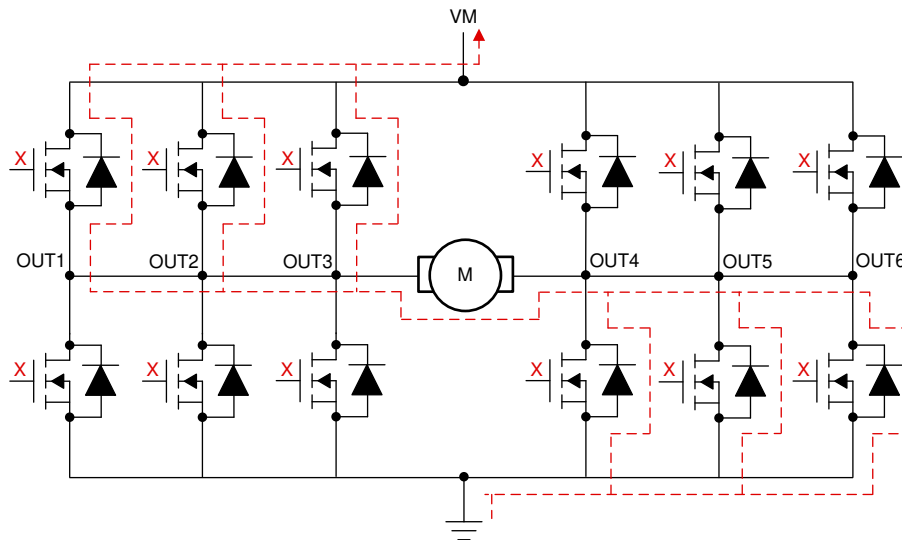

Figure 41. Parallel Mode (Coast from Reverse Direction)

The low-side braking of the motor during all the low-side FET's of the driver turning ON is shown in [Figure 42](#). In this case, the motor is considered to be operating in forward direction (current flow from OUT1/2/3 to OUT4/5/6) and then braking is applied. Similarly, for the high-side braking, all high-side FET's of the driver are turned ON as shown in [Figure 43](#).

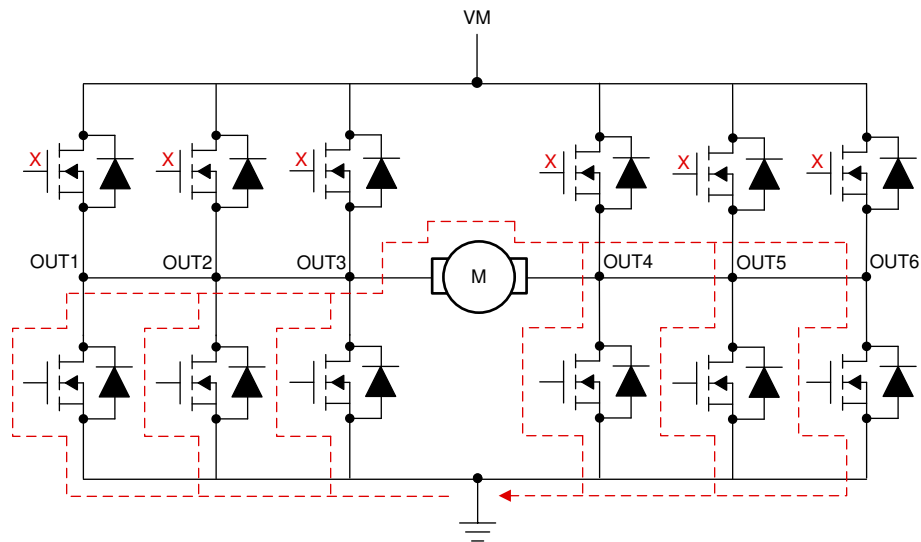

Figure 42. Parallel Mode (Brake - Low-Side)

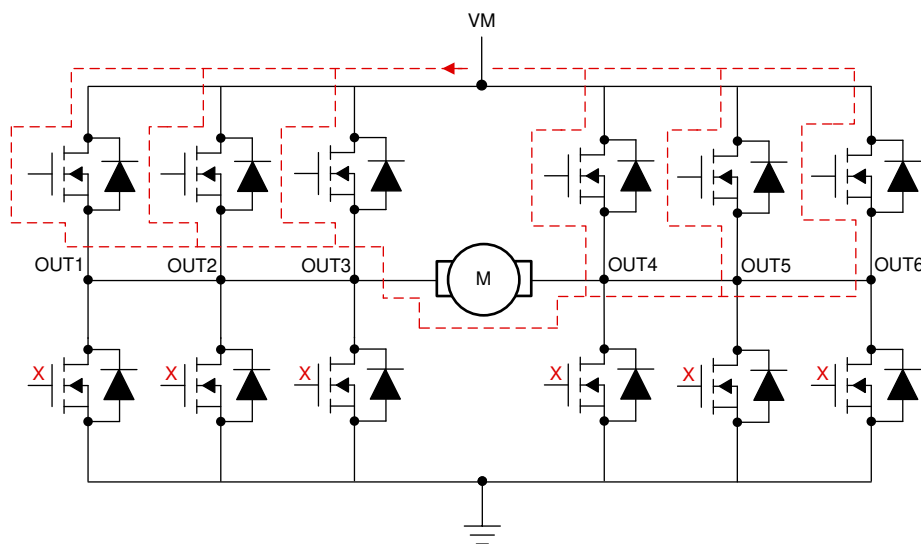

Figure 43. Parallel Mode (Brake - High-Side)

8.3.1.1.4 Parallel Mode (PWM Operation)

The half-bridges connected in parallel mode can be configured in the chopping mode by enabling the PWM switching on any particular group of high-side or low-side half-bridges or both group of half-bridges. For PWM operation in parallel mode, all half-bridges is to be mapped to a single PWM channel selected from any of the 4 PWM channels to avoid any delay in the PWM durations which can lead to undesired OCP condition. The user has the flexibility to select the PWM frequency of channels out of 4 settings of 80-Hz, 100-Hz, 200-Hz and 2-kHz and the duty adjustment which supports 8-bit resolution. Following steps enable the PWM operation with driver connected for parallel mode and are explained below.

1. PWM Configuration
2. Free-Wheeling Mode (Synchronous Rectification) Disable / Enable
3. PWM Channels Mapping
4. PWM Channels Configuration (PWM Frequency and PWM Duty)
5. PWM Generators Disable
6. Half-Bridge Enable
7. PWM Generators Enable

8.3.1.1.4.1 PWM Configuration

The PWM control register (PWM_CTRL_1 and PWM_CTRL_2) are used to select the operation of particular half-bridges in the PWM mode. Considering a case for the motor movement in forward direction as shown in [Figure 40](#), with low-side FETs of OUT4, OUT5 and OUT6 operating in PWM mode. The HBX_PWM bit in PWM control register is set to enable the PWM switching in selected half-bridges as shown below:

- HB4_PWM = 1b
- HB5_PWM = 1b
- HB6_PWM = 1b

8.3.1.1.4.2 Free-Wheeling Mode (Synchronous Rectification) Disable / Enable

The synchronous rectification of the half bridges operating in PWM mode (OUT4, OUT5 and OUT6) are enabled by setting the corresponding HBX_FW bits in free-wheeling control register (FW_CTRL_1 and FW_CTRL_2). By default, the synchronous rectification mode is disabled.

- HB4_FW = 1b
- HB5_FW = 1b
- HB6_FW = 1b

[Figure 44](#) shows the parallel operation of half-bridges in PWM mode with synchronous rectification disabled. As shown in this figure, during the PWM off time, the high-side diode of the OUT4, OUT5 and OUT6 conducts to close the current path required for motor.

When synchronous rectification mode is enabled, the high-side FETs of OUT4, OUT5 and OUT6 starts conducting during the PWM OFF time to close the motor current path as shown in [Figure 45](#).

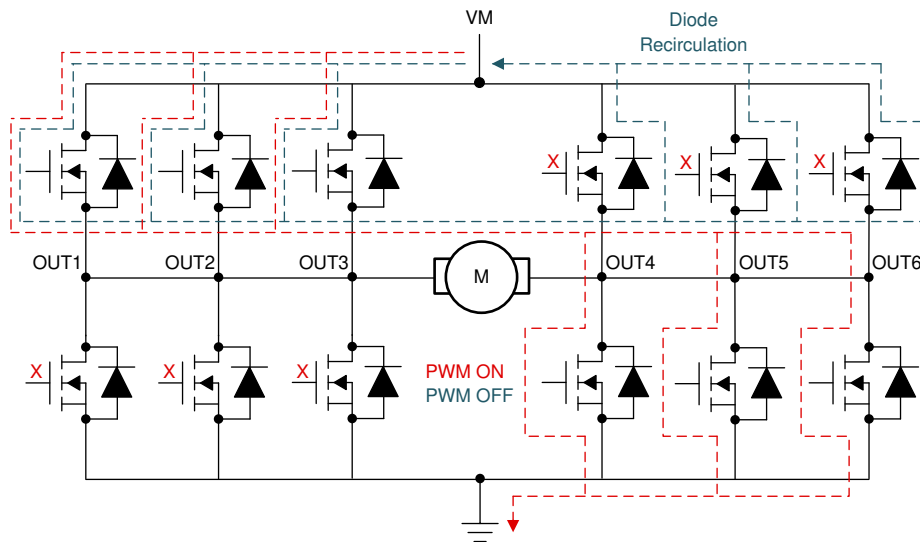

Figure 44. Parallel Mode (PWM with Synchronous Rectification = OFF)

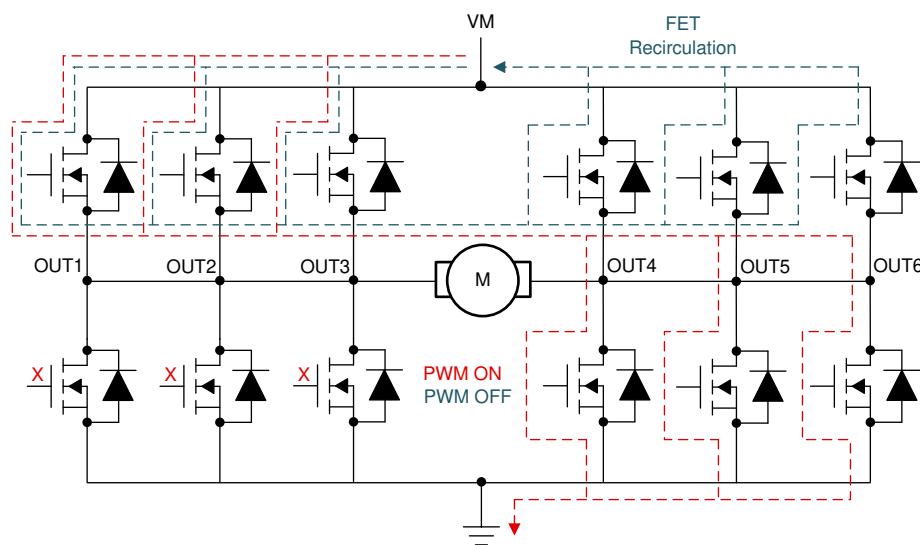

Figure 45. Parallel Mode (PWM with Synchronous Rectification = ON)

8.3.1.1.4.3 PWM Channels Mapping

The low-side FET's of half-bridges OUT4, OUT5 and OUT6 are mapped to any of the PWM generator by using the HBX_PWM_MAP bits in PWM mapping control registers. For parallel operation, all the half-bridges operating in PWM mode is mapped to a single PWM generator. Considering that PWM generator-4 is used for the mapping of half-bridges, following bits of the PWM_MAP_CTRL_X registers are affected:

- HB4_PWM_MAP = 11b
- HB5_PWM_MAP = 11b
- HB6_PWM_MAP = 11b

NOTE

If the PWM of any channel is enabled, then it is mapped to PWM generator-1 by default.

8.3.1.1.4.4 PWM Channels Configuration (PWM Frequency and PWM Duty)

The PWM_CHx_FREQ bits of PWM frequency control registers (PWM_FREQ_CTRL_X) is used to select the frequency of PWM generator. Moreover, the PWM duty of each channel is controlled by the PWM duty control register (PWM_DUTY_CTRL_X). Considering a frequency of 2-kHz is selected for the PWM operation (for PWM Generator-4), following frequency control and duty control registers are effected:

- PWM_CH4_FREQ = 11b
- PWM_CH4_FREQ = '8-bit duty'

8.3.1.1.4.5 PWM Generators Disable

The PWM generators are disabled to ensure that all the half-bridges are turned-on at same time to avoid false OCP conditions for supporting higher current operation. The false OCP condition can arise due to the minimum time required for the SPI delay to switch on various half-bridges available in different registers. This can cause higher current (OCP condition) in one of the paralleled half-bridge while other half-bridge turning ON is delayed to the SPI register write delay and the propagation delay. Therefore, this sequence includes disabling the PWM generators initially, then enabling half-bridges and followed by enabling the PWM generators to avoid such issue. The PWM generator-4 is disabled by using the following command in the PWM_CTRL_X registers:

- PWM_CH4_DIS = 1b

NOTE

All PWM generators are enabled by default (Default value of PWM_CTRL_X registers is 00h).

8.3.1.1.4.6 Half-Bridge Enable

Once the PWM generators are disabled, the high-side and low-side FETs in half-bridges to be paralleled are enabled. High-side switches (connected in parallel) operating in continuous mode are enabled using the following bits in the OP_CTRL_X registers:

- HB1_HS_EN = 1b
- HB2_HS_EN = 1b
- HB3_HS_EN = 1b

Moreover, the low-side switches (connected in parallel) operating in PWM mode are enabled using the following bits in the OP_CTRL_X:

- HB4_LS_EN = 1b
- HB5_LS_EN = 1b
- HB6_LS_EN = 1b

8.3.1.1.4.7 PWM Generators Enable

After the half-bridges are enabled, the PWM generators are also enabled for tuning-on the respective FETs operating in PWM mode. For this case, the low-side FETs of OUT4, OUT5 and OUT6 are turned ON for PWM operation connected to PWM generator-4. The PWM generator is enabled by the bits in the PWM_CTRL_X registers as shown:

- PWM_CH4_DIS = 0b

8.3.1.2 Half-Bridge Drive Architecture

8.3.1.2.1 Slew Rate

An adjustable gate-drive current control to the MOSFETs of half-bridges is implemented to achieve the slew rate control. The MOSFET VDS slew rates are a critical factor for optimizing radiated emissions, energy and duration of diode recovery spikes and switching voltage transients related to parasitics. These slew rates are predominantly determined by the rate of gate charge to internal MOSFETs as shown in [Figure 46](#).

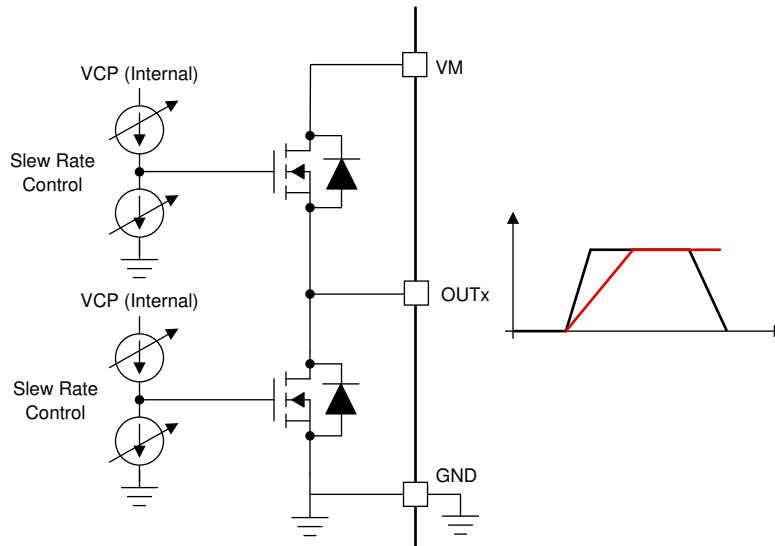

Figure 46. Slew Rate Circuit Implementation

The slew rate of each half-bridge can be adjusted by HBX_SR bits in Slew Rate control register (SR_CTRL_1 and SR_CTRL_2). Each half-bridge can be selected to a slew rate of 0.6-V/ μ s or 2.5-V/ μ s. The slew rate is calculated by the rise-time and fall-time of the voltage on OUTx pin as shown in [Figure 47](#). The slew rate (SR) is calculate as shown in

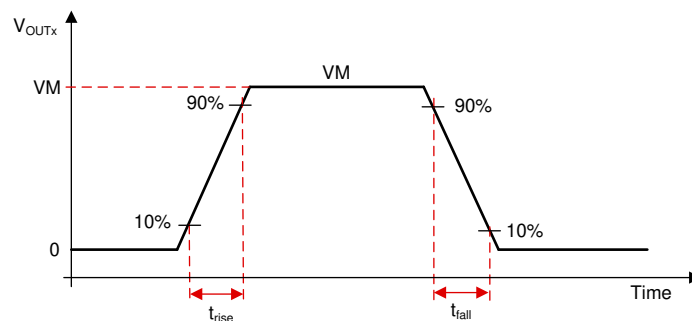

Figure 47. Slew Rate Timings

8.3.1.2.2 Cross Conduction (Dead Time)

The device is fully protected for any cross conduction of MOSFETs. In half-bridge configuration, the operation of high-side and low-side MOSFETs are ensured to avoid any shoot through currents by inserting a dead time (t_{dead}). This is implemented by sensing the gate-source voltage (V_{GS}) of the high-side and low-side MOSFETs and ensured that V_{GS} of high-side MOSFET has reached below turn-off levels before switching on the low-side MOSFET of same half-bridge as shown in Figure 48 and Figure 49.

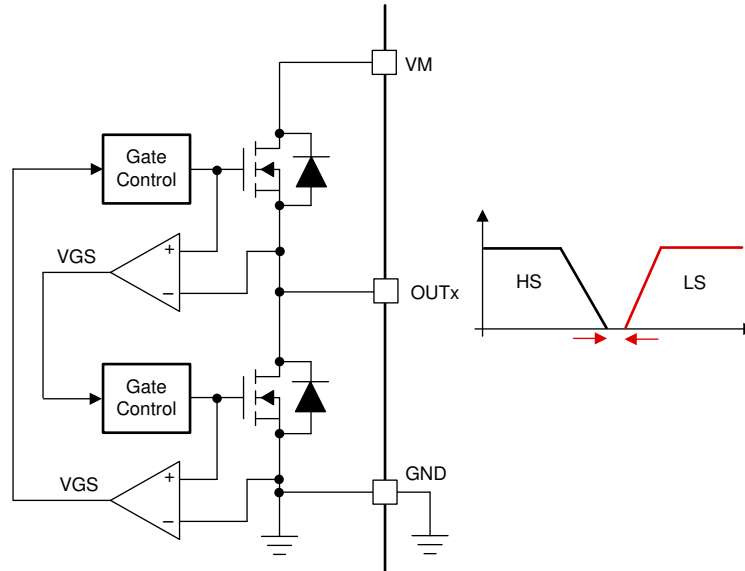

Figure 48. Cross Conduction Protection

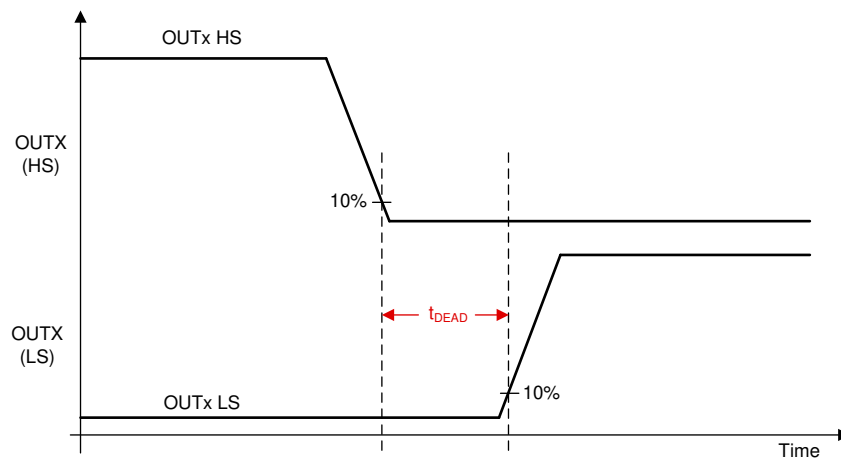

Figure 49. Dead Time

8.3.1.2.3 Propagation Delay

Propagation delay refers to the delay time from SPI valid condition to OUTx going high (10% level) as shown in Figure 50. The propagation constitutes of three major parameters.

1. Digital delay for SPI command decode.
2. Analog delay for driver switch-on and gate current charging delay.
3. Slew rate delay for OUTx node to reach 10% of the final settling value.

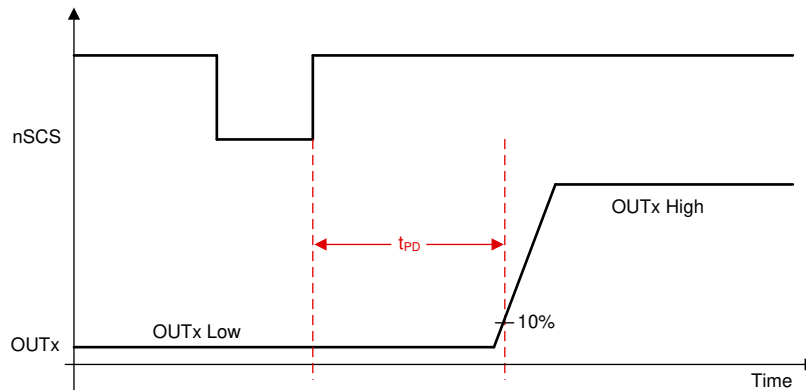

Figure 50. Propagation Delay

8.3.2 Pin Diagrams

This section presents the I/O structure of all digital input and output pins.

8.3.2.1 Logic Level Input Pin (nSLEEP, SCLK and SDI)

Figure 51 shows the input structure for the logic levels pins, nSLEEP, SCLK and SDI. The input can be with a voltage or external resistor. It is recommended to put SCLK and SDI pin low in device sleep mode to reduce leakage current through internal pull-down resistors.

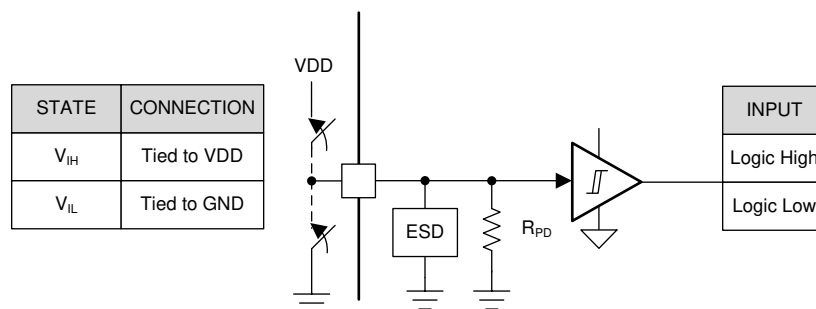

Figure 51. Logic Level Input Pin Structure (nSLEEP, SCLK and SDI)

8.3.2.2 Logic Level Input Pin (nSCS)

Figure 52 shows the input structure for the logic levels pin, nSCS. The input can be with a voltage or external resistor.

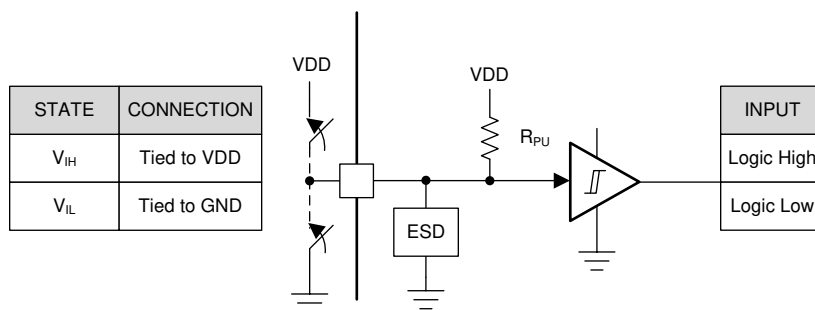

Figure 52. Logic Level Input Pin Structure (nSCS)

8.3.2.3 Open Drain Output Pin (nFAULT)

Figure 53 shows the structure of the open-drain output pin, nFAULT. The open-drain output requires an external pull resistor to function properly.

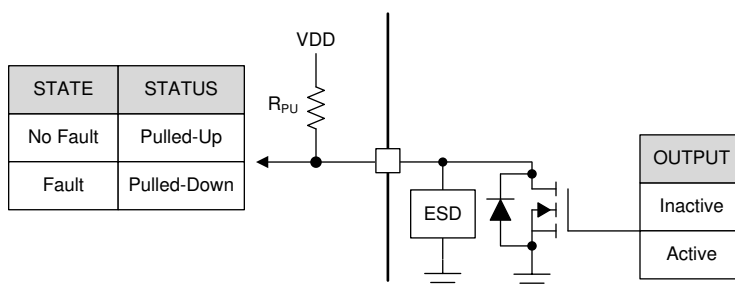

Figure 53. Open Drain Output Pin Structure (nFAULT)

8.3.2.4 Push Pull Output Pin (SDO)

Figure 54 shows the structure of push-pull pin, SDO.

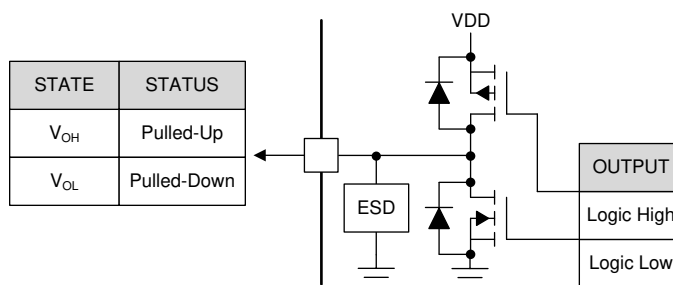

Figure 54. Push Pull Output Pin (SDO) Structure

8.3.3 Protection Circuits

The DRV89xx-Q1 device is fully protected against undervoltage, overcurrent, and over-temperature events.

8.3.3.1 VM Supply Undervoltage Lockout (UVLO)

If at any time the input supply voltage on the VM pin falls below the V_{UVLO} threshold, all of the half-bridges are disabled, the charge pump is disabled, and the nFAULT pin is driven low as shown in Figure 55. The UVLO bit is also latched high in the IC status (IC_STAT) register. Normal operation resumes (driver operation and the nFAULT pin is released) when the VM undervoltage condition is removed. The UVLO bit remains set until cleared through the CLR_FLT bit.

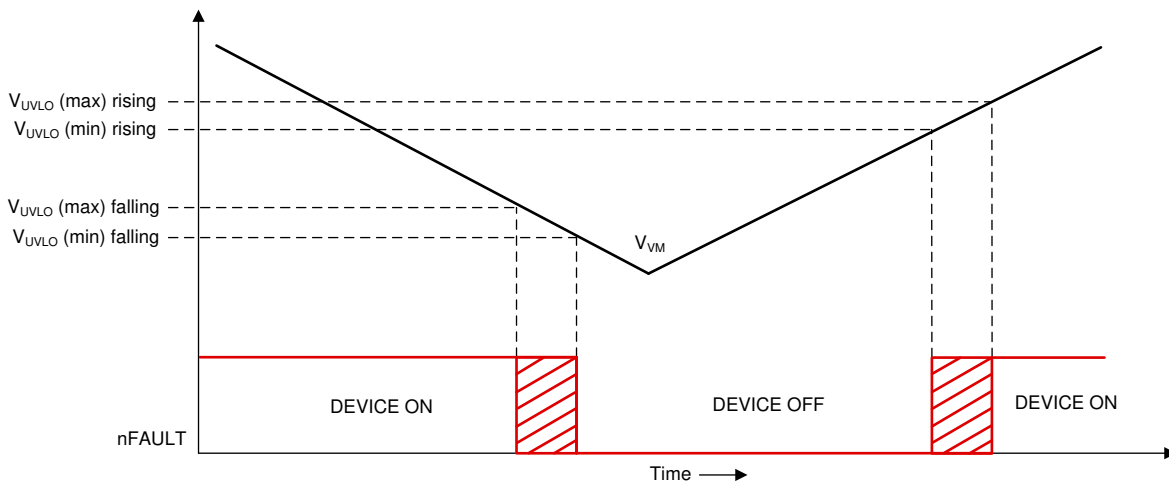

Figure 55. VM UVLO Operation

8.3.3.2 VM Supply Overvoltage Protection (OVP)

If at any time the input supply voltage on the VM pin rises above the V_{OVP} threshold, all of the half-bridges are disabled, the charge pump is disabled, and the nFAULT pin is driven low as shown in Figure 56. The OVP bit is also latched high in the IC status (IC_STAT) register. Normal operation resumes (driver operation and the nFAULT pin is released) when the VM overvoltage condition is removed. The OVP bit remains set until cleared through the CLR_FLT bit.

An extended overvoltage operation is also supported in this device for higher over-voltage range up to 32-V. This operation is enabled by setting the EXT_OVP bit in the configuration (CONFIG_CTRL) register.

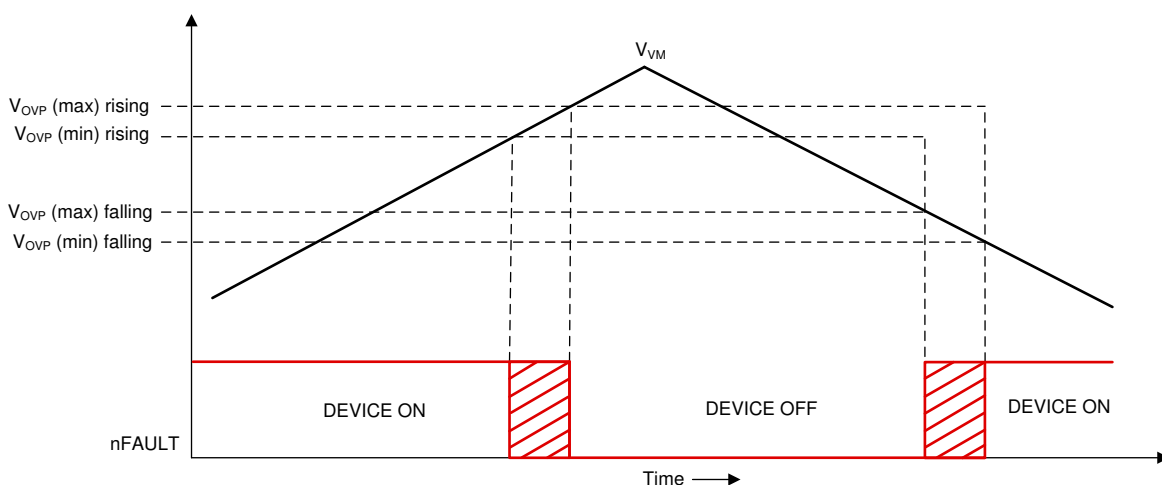

Figure 56. Over Voltage Protection

8.3.3.3 Logic Supply Power on Reset (POR)

If at any time the input logic supply voltage on the VDD pin falls below the V_{POR} threshold or the nSLEEP pin is toggled (high to low), all of the half-bridges are disabled and the charge pump is disabled, as shown in Figure 57. Normal operation resumes (driver operation) when the VDD undervoltage condition is removed or the nSLEEP pin is latched high. The NPOR bit is reset and latched low in the IC status (IC_STAT) register once the device presumes VDD. The NPOR bit remains in reset condition until cleared through the CLR_FLT bit.

If the device has successfully waked up, then the NPOR bit is automatically latched high once the CLR_FLT command is issued.

NOTE

NPOR is not reported to nFAULT pin.

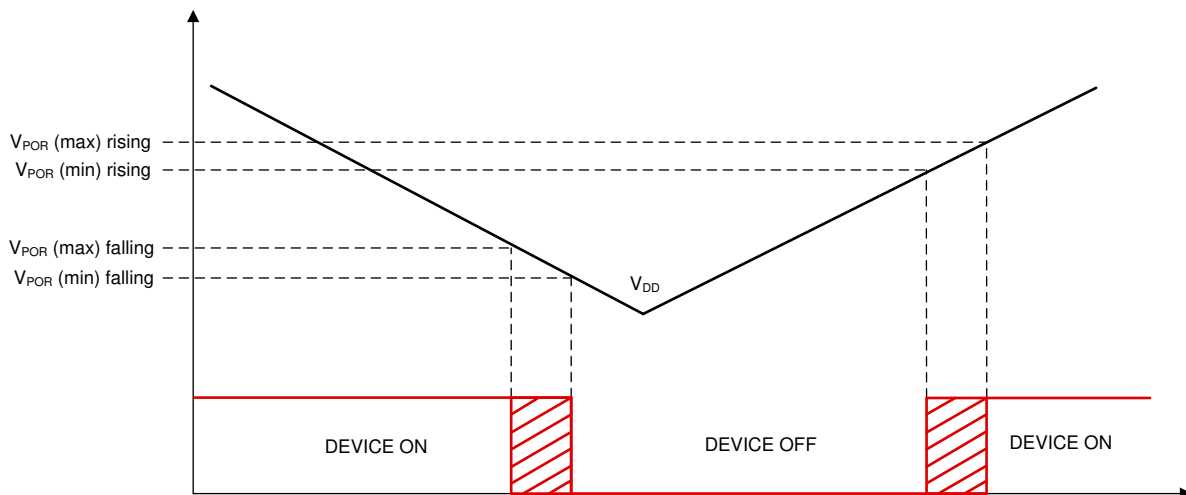

Figure 57. VDD UVLO Operation

8.3.3.4 Overcurrent Protection (OCP)

A current-limit circuit on each MOSFET limits the current through the MOSFET by removing the gate drive signal. If this current limit stay active for longer than the t_{OCP} deglitch time, the high-side and the low-side FETs in the corresponding half bridge are disabled and the nFAULT pin is driven low. The OCP bit in the IC status (IC_STAT) register and corresponding bit in overcurrent protection status register (OCP_STAT_X) register is latched high. The charge pump remains active during this condition. The OCP bit in the IC status (IC_STAT) register and corresponding bits (HBX_HS_OCP / HBX_LS_OCP) in overcurrent protection status register (OCP_STAT_X) register remains set until cleared through the CLR_FLT bit.

User also has the programmability of disabling the OCP fault on the nFAULT pin by setting the OCP_REP bit in the CONFIG_CTRL register.

The device also provides two slew-rate options for the device turn-off during an OCP event which can be programmed via the PL_MODE_EN bits in OLD_CTRL_2 register. The default option (PL_MODE_EN = 00b) is the faster slew rate option (typical around $1\mu s$) which can be used for the single bridge operation. The slower option (PL_MODE_EN = 01b) provides a slower slew rate (half-bridge slew rate, HBX_SR) which can be used for the higher current applications in device parallel mode operation.

Table 6. Overcurrent Protection

Drive Current	BRIDGE CONFIGURATION	REGISTER SETTINGS	BRIDGE STATE	nFAULT PIN		BITS AFFECTED	RECOVERY
				OCP_REP = 0	OCP_REP = 1		
$I_{LOAD} < I_{OCP}$	OUT1 High-Side ON	HB1_HS_EN = 1	ENABLED	HIGH	HIGH	N/A	N/A
	OUT2 Low-Side ON	HB1_LS_EN = 1	ENABLED	HIGH	HIGH		
$I_{LOAD} < I_{OCP}$	Full Bridge (OUT1/2) Forward Direction	HB1_HS_EN = 1 HB2_LS_EN = 1	ENABLED	HIGH	HIGH		
	Full Bridge (OUT1/2) Reverse Direction	HB1_LS_EN = 1 HB2_HS_EN = 1	ENABLED	HIGH	HIGH		
I_{SHORT} or $I_{LOAD} > I_{OCP}$	OUT1 High-Side ON OUT1 Short to GND	HB1_HS_EN = 1	Hi-Z	LOW	HIGH	OCP = 1 (IC_STAT) HB1_HS_OCP = 1	OCP Condition Removed CLR_FLT = 1
	OUT1 Low-Side ON OUT1 Short to VM	HB1_LS_EN = 1	Hi-Z	LOW	HIGH	OCP = 1 (IC_STAT) HB1_LS_OCP = 1	
I_{SHORT} or $I_{LOAD} > I_{OCP}$	Full Bridge (OUT1/2) Forward Direction OUT1 / OUT2 Short	HB1_HS_EN = 1 HB2_LS_EN = 1	Hi-Z	LOW	HIGH	OCP = 1 (IC_STAT) HB1_HS_OCP = 1 or HB2_LS_OCP = 1 ⁽¹⁾	
	Full Bridge (OUT1/2) Reverse Direction OUT1 / OUT2 Short	HB1_LS_EN = 1 HB2_HS_EN = 1	Hi-Z	LOW	HIGH	OCP = 1 (IC_STAT) HB1_LS_OCP = 1 or HB2_HS_OCP = 1 ⁽²⁾	

- (1) Either of the HB1_HS_OCP or HB2_LS_OCP will set depending upon which half-bridge OCP trigger first.
 (2) Either of the HB1_LS_OCP or HB2_HS_OCP will set depending upon which half-bridge OCP trigger first.

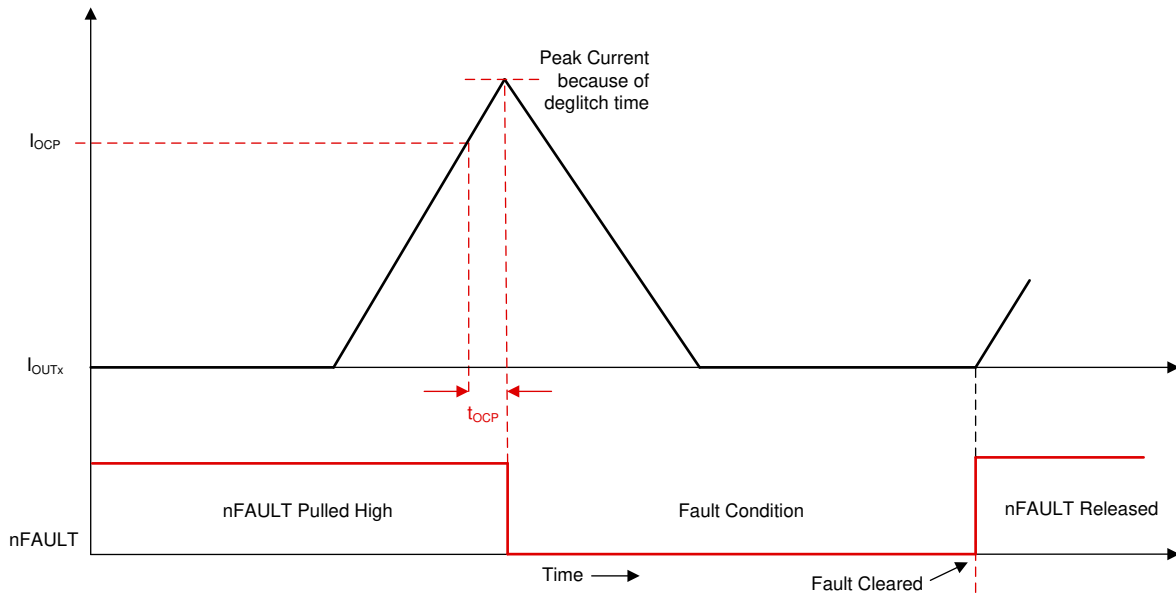

Figure 58. Over Current Protection

8.3.3.5 Open-load detection (OLD)

The DRV89XX-Q1 devices implement multiple open-load detection schemes to allow the controller to determine if a load is connected to the OUTX terminals. The OLD schemes available in DRV89XX-Q1 are listed below. [Table 7](#) summarizes the use-cases for each OLD scheme.

- [Active OLD](#)
- [Low-Current Active OLD](#)
- [Negative-Current Active OLD](#)
- [Passive OLD](#) (only available in DRV8908-Q1, DRV8906-Q1 and DRV8904-Q1)

Table 7. Summary of OLD features

	PASSIVE OLD	ACTIVE OLD	LOW-CURRENT ACTIVE OLD	NEGATIVE-CURRENT ACTIVE OLD
Part numbers	DRV8908/06/04-Q1	DRV8912/10/08/06/04-Q1		
When is it used	Detects open-load condition prior to enabling the outputs	Detects the open-load condition while driving a load	Detects the open-load condition while driving a load with small operating current	Detects the open-load condition during current re-circulation (on high-side or low-side) when synchronous rectification is enabled for both half-bridge and full-bridge configurations
State of OUTx for valid OLD	Hi-Z (outputs disabled)	H/L	L	H/L
OLD Trigger Condition	$V_{OLx_HS(+)} > V_{OLx_HS}$ or $V_{OLx_LS(-)} < V_{OLx_LS}$	$I_{OUTX} < I_{OLD}$	$I_{OUTX} < I_{OLD_LOW}$	$I_{OUTX} > -I_{OLD_NEG}$ $I_{OUTX} < I_{OLD}$
Tradeoffs	Passive OLD sequence is not enabled if any other fault other than OCP/OLD is present.	A false flag can occur during current re-circulation if synchronous rectification is ON. Enabling Negative-current OLD will solve this. A false flag can also occur if the operating current for the load is small (below I_{OLD} threshold). See Low-current OLD for solution.	Only applicable for the current flowing in the low-side FETs. The I_{OCP} for the low-side FET is also reduced by 11 times. The $R_{DS(ON)}$ of the low-side FET will increase by 11 times, hence the thermal performance has to be monitored.	Only functional during current re-circulation, however it works in conjunction with active OLD. This feature is not needed if synchronous rectification is disabled.
Can be used with other OLD schemes	No	Negative-current OLD and low-current OLD	Active OLD and negative-current OLD	Active OLD and low-current OLD

8.3.3.5.1 Active OLD

Active OLD can identify an open-load condition on the OUTX pins while driving a load. As shown in [Figure 59](#), the DRV89xx identifies an open-load fault condition when the current through the MOSFET (I_{OUTX}) is lower than the open-load current threshold (I_{OLD}) for longer than the open-load deglitch time (t_{OLD}). At that point the device takes the following actions.

- OLD bit in the IC status (IC_STAT) register sets to 1
- HBX_HS_OLD or HBX_LS_OLD bit in the open-load status register (OLD_STAT_X) sets to 1 (depending if the fault is on the high-side MOSFET or low-side MOSFET, respectively).
- nFAULT pin is driven low to indicate a fault to the controller.

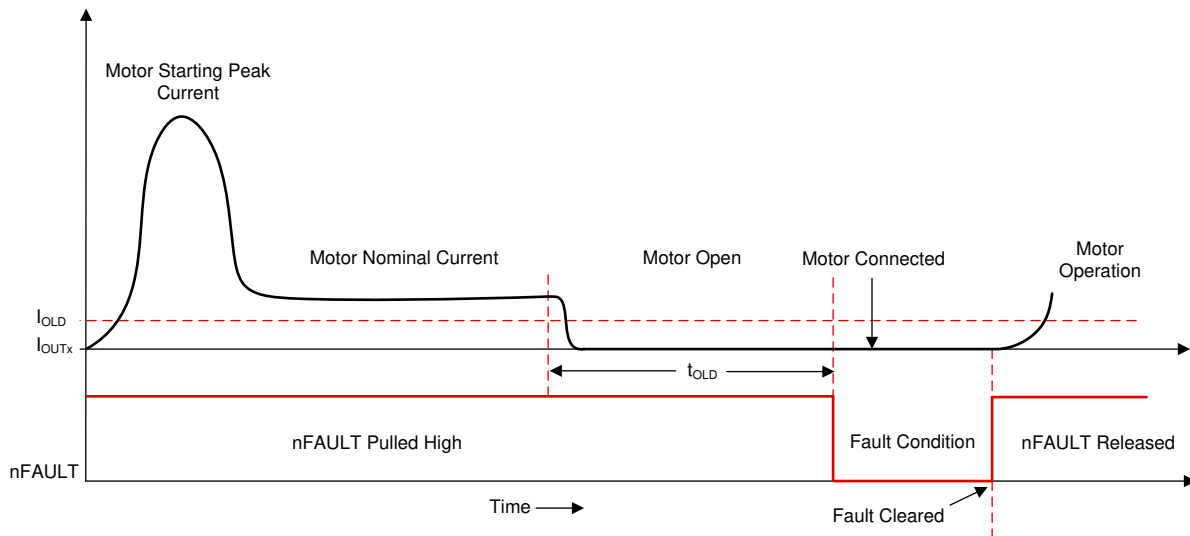

Figure 59. Active open-load detection

Normal operation resumes (driver operation resumes, the nFAULT pin goes high, OLD bit is reset to 0) when the open-load condition is removed (the user reconnects the load to the OUTX connection) and the controller writes the CLR_FLT bit to 1.

NOTE

After the open-load fault condition is removed, the nFAULT pin will be driven high and the fault status are removed when,

- CLR_FLT command is issued after deglitch time (t_{OLD}) while OUTX is set high.
- CLR_FLT command is issued after OUTX is set to Hi-Z.
- CLR_FLT command is issued after HBX_OLD_DIS bit is set.

By default, OLD on the DRV89xx-Q1 devices is enabled. The OLD control registers (OLD_CTRL_1 and OLD_CTRL_2) allow the user to disable OLD on the OUTX pins with the HBX_OLD_DIS bits. The OLD_OP bit in the OLD_CTRL_2 register determines the response of the device to an active OLD fault. If OLD_OP = 0, the OUTX pins go to the Hi-Z state to stop driving the outputs. If OLD_OP = 1, the OUTX pins stay in their previous state and do not react to the OLD fault unless the user takes action. Similarly, the OLD_REP bit determines if the OLD fault will report on the nFAULT pin or only in the IC_STAT register. [Table 8](#) summarizes the open-load detection feature and conditions.

NOTE

By default the OLD feature is enabled, the outputs disable (go Hi-Z) when the OLD flags, and the nFAULT pin will report the OLD.

Table 8. OLD Configuration

LOAD / OPEN	REGISTER SETTINGS	OLD_OP	OLD_REP	OUT1	OUT2	nFAULT	BITS EFFECTED	RECOVERY
Half-Bridge Load Connected	HB1_HS_EN = 1	X	X	H	X	HIGH	N/A	N/A
	HB1_LS_EN = 1	X	X	L	X	HIGH		
Full-Bridge Load Connected	HB1_HS_EN = 1 HB2_LS_EN = 1	X	X	H	L	HIGH		
	HB1_LS_EN = 1 HB2_HS_EN = 1	X	X	L	H	HIGH		

Table 8. OLD Configuration (continued)

LOAD / OPEN	REGISTER SETTINGS	OLD_OP	OLD_REP	OUT1	OUT2	nFAULT	BITS EFFECTED	RECOVERY
Half-Bridge Open	HB1_HS_EN = 1	0	0	Hi-Z	X	LOW	OLD = 1 (IC_STAT) HB1_HS_OLD = 1	OLD Condition Removed CLR_FLT = 1
		0	1	Hi-Z	X	HIGH		
		1	0	H	X	LOW		
		1	1	H	X	HIGH		
	HB1_LS_EN = 1	0	0	Hi-Z	X	LOW	OLD = 1 (IC_STAT) HB1_LS_OLD = 1	
		0	1	Hi-Z	X	HIGH		
		1	0	L	X	LOW		
		1	1	L	X	HIGH		
Full-Bridge Open	HB1_HS_EN = 1 HB2_LS_EN = 1	0	0	Hi-Z	Hi-Z	LOW	OLD = 1 (IC_STAT) HB1_HS_OLD = 1 or HB2_LS_OLD = 1 ⁽¹⁾	
		0	1	Hi-Z	Hi-Z	HIGH		
		1	0	H	L	LOW		
		1	1	H	L	HIGH		
	HB1_LS_EN = 1 HB2_HS_EN = 1	0	0	Hi-Z	Hi-Z	LOW	OLD = 1 (IC_STAT) HB1_LS_OLD = 1 or HB2_HS_OLD = 1 ⁽²⁾	
		0	1	Hi-Z	Hi-Z	HIGH		
		1	0	L	H	LOW		
		1	1	L	H	HIGH		

(1) Either of the HB1_HS_OLD or HB2_LS_OLD will set depending upon which half-bridge OLD triggers first.

(2) Either of the HB1_LS_OLD or HB2_HS_OLD will set depending upon which half-bridge OLD triggers first.

8.3.3.5.1.1 Negative-current OLD

The DRV89XX-Q1 device also includes a negative-current OLD mode. The negative current can flow either through the body diode of high-side FET or the FET itself depending on whether or not the channel is configured for synchronous rectification. [Figure 60](#) shows the current re-circulation through the body diode of the high-side FET when the synchronous rectification mode is OFF (i.e. HB2_FW = 0). In this case, the active OLD will not falsely report an open-load condition since the OLD circuit only enables when the FET is ON. Negative-current OLD will also work during re-circulation through the low-side FETs.

[Figure 61](#) shows the negative current re-circulation through the high-side FET when synchronous rectification is ON (i.e. HB2_FW = 1). In this scenario, for default operation (OLD_NEG_EN = 0), the device can show a false open-load fault since the FET current is lower than the positive OLD threshold. However, when negative-current OLD mode is enabled, the device will only flag an open-load fault if $I_{OUTX} < I_{OLD_NEG}$. This mode is enabled by setting the OLD_NEG_EN bit in OLD_CTRL3 register.

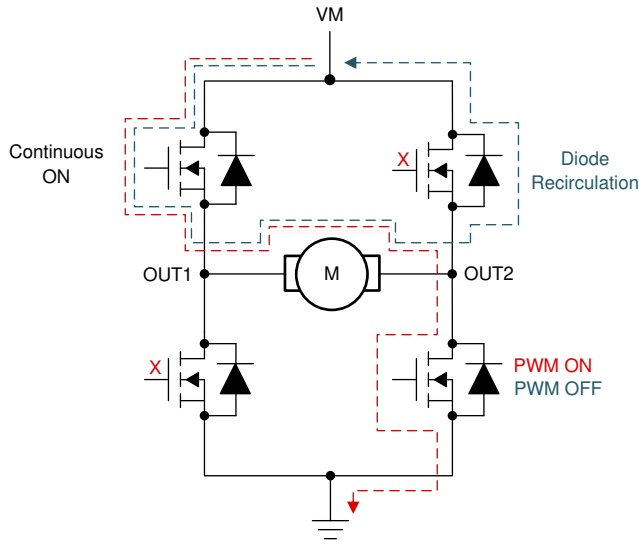

Figure 60. Negative Current Flow in OUT2 by Body Diode of High-Side FET

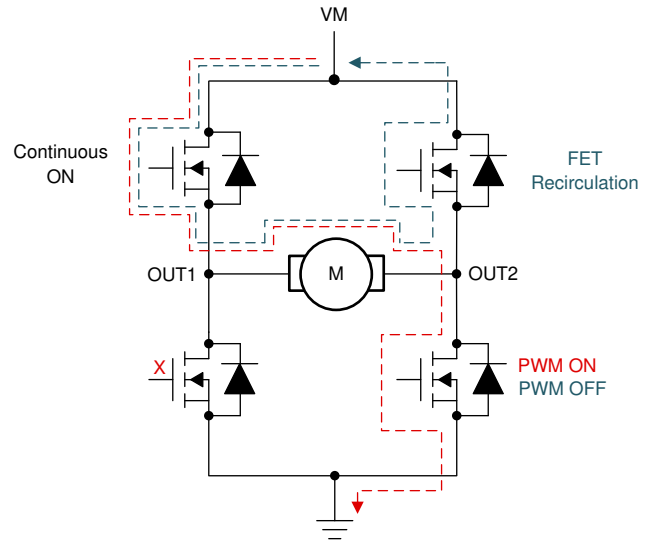

Figure 61. Negative Current Flow in High-Side FET of OUT2 Channel

Figure 62 shows the waveforms of false open-load detection when the negative-current OLD setting is disabled ($OLD_NEG_EN = 0$). As shown in this figure, the high-side FET of the OUT1 channel is always switched ON and the low-side and high-side FET of the OUT2 channel are operating in complimentary way (i.e. synchronous rectification mode is enabled). In synchronous rectification, the current flows in negative direction from OUT2 to VM (i.e. FET Source to Drain) during the high-side FET conduction. Initially, for the first PWM cycle, the OLD mode is disabled to show the currents in different FETs during the motor operation. When OLD is enabled in second PWM cycle, then the device registers a false open-load detect during the high-side FET conduction as shown in Figure 62. The nFAULT pin is pulled low and both high-side and low-side FET of OUT2 channels are disabled. The body diode of the high side FET (OUT2) conducts to complete the motor current path.

This false detection of open load is eliminated by enabling the negative-current OLD setting ($OLD_NEG_EN = 1$). As shown in Figure 63, the negative OLD current setting (I_{OLD_NEG}) is enabled for the high-side FET of OUT2 channel. This setting allows the negative current path (from source to drain) in high-side FET. The nFAULT pin is latched high and OUT2 channel is not disabled when OLD is enabled in second PWM cycle.

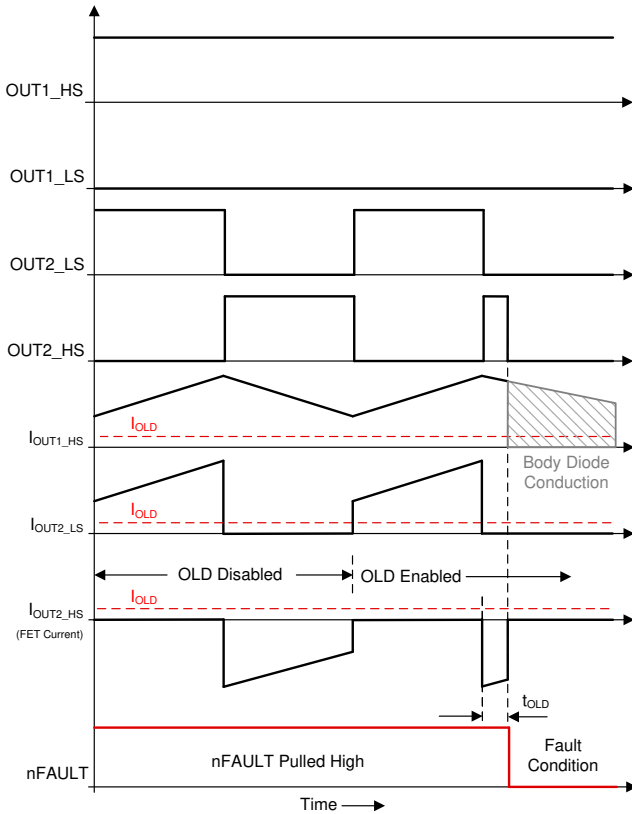

Figure 62. Waveforms Showing False OLD With Negative-Current OLD Disabled

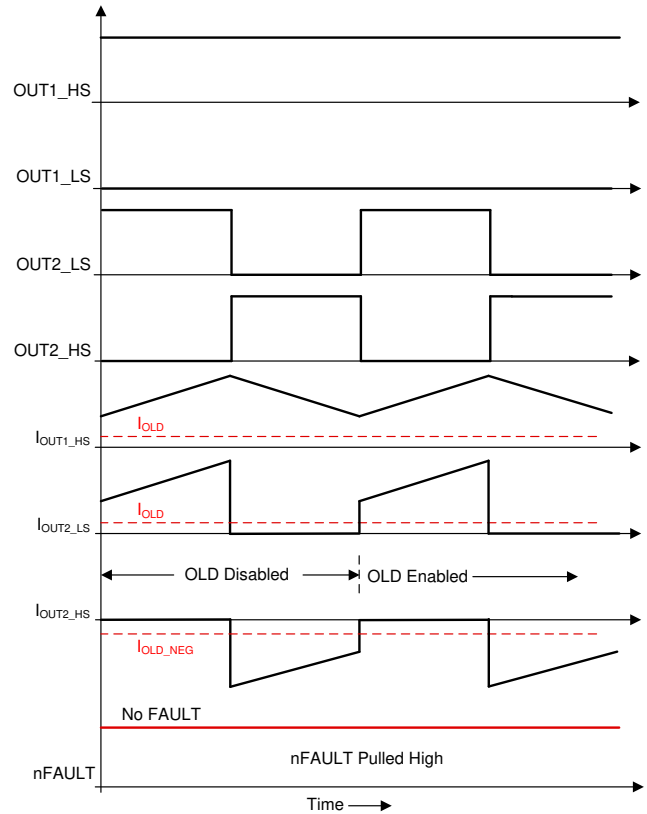

Figure 63. Waveforms Showing Operation with Negative-Current OLD Enabled

8.3.3.5.2 Low-current OLD

Low-current open-load detection is another type of active open-load detection in the DRV89XX-Q1 devices. In low-current open-load detection, the current detection threshold is around 10x lower than the active open-load detection scheme. This feature gives the user flexibility to detect a valid open-load condition when driving loads that require low current.

As shown in Figure 64, if the low-side MOSFET is in operating condition (switched-ON) and the current flowing in the particular MOSFET is lower than the low-current active open-load current threshold (I_{OLD_LOW}) for at least open-load detection deglitch time (t_{OLD}), then an open-load condition is detected. The OLD bit in the IC status (IC_STAT) register is set, the HBX_LS_OLD bit in the open-load status register (OLD_STAT_X) is set and nFAULT pin is driven low during an open-load detect. Normal operation resumes (driver operation and the nFAULT pin is released) when the open-load condition is removed and CLR_FLT command is issued. The OLD bit remains set until cleared through the CLR_FLT bit.

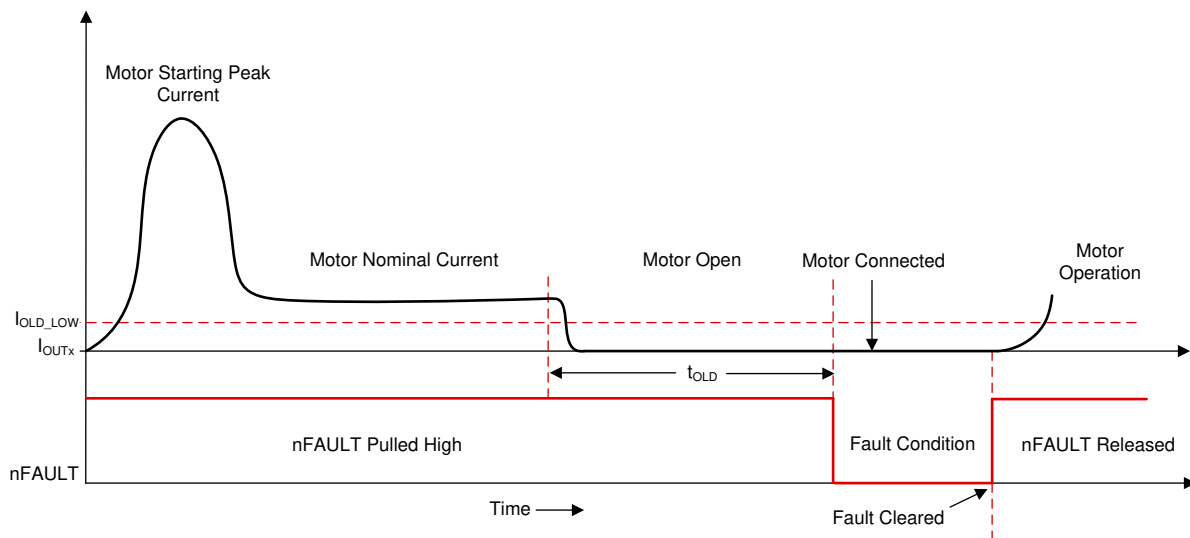

Figure 64. Low-Current OLD

NOTE

The low-current OLD has following limitations

- This feature is only applicable for the current flowing in low-side FET.
- Once this mode is enabled the corresponding over-current threshold for the low-side FET is also reduced by 11 times (~120 mA min.).
- The $R_{DS(on)}$ of the low side FET will increase by 11 times (~7.5 Ω typical), hence the thermal performance has to be monitored. However, for the lower current the thermal dissipation is limited.

Figure 65 shows the flowchart for implementing the low-current active OLD in continuous mode of operation. Following are the steps to configure and detect the low-current active OLD in the DRV89XX-Q1 device.

1. Enable OLD by setting the OLD_OP bit in OLD_CTRL_2 register. This setting will ensure that the OUTX outputs continue to operate when and OLD fault occurs.
2. Enable the full-bridge operation by setting the individual HBX_HS_EN/HBX_LS_EN bits in operation control (OP_CTRL_1, OP_CTRL_2 and OP_CTRL_3) registers.
3. Check for the nFAULT pin status and the OLD fault in the IC_STAT register.
4. If the nFAULT pin is low and the OLD fault is high, then check for the individual HBX_HS_OLD/HBX_LS_OLD bits in OLD status (OLD_STAT_1, OLD_STAT_2 and OLD_STAT_3) registers.
5. Disable OLD using the HBX_OLD_DIS bits for the OUTX pins acting as high-side drivers.
6. Enable the low-current OLD mode for the half-bridge which low-side is operating by using the HBX_LOLD_EN bit in OLD control (OLD_CTRL_3 and OLD_CTRL_4) registers. This will also disable the high-side OLD for the particular half-bridge.
7. Wait for the open-load deglitch time (t_{OLD}).
8. Issue the clear fault command (CLR_FLT) to release the nFAULT pin and clear the OLD bits if low-current OLD is not detected.
9. If the OLD bit is high and the nFAULT pin is not released (low), then low-current OLD fault is detected.

NOTE

The low-current OLD is applicable only for low-side FETs. The user has to enable the low-current OLD mode for the corresponding low-side FET.

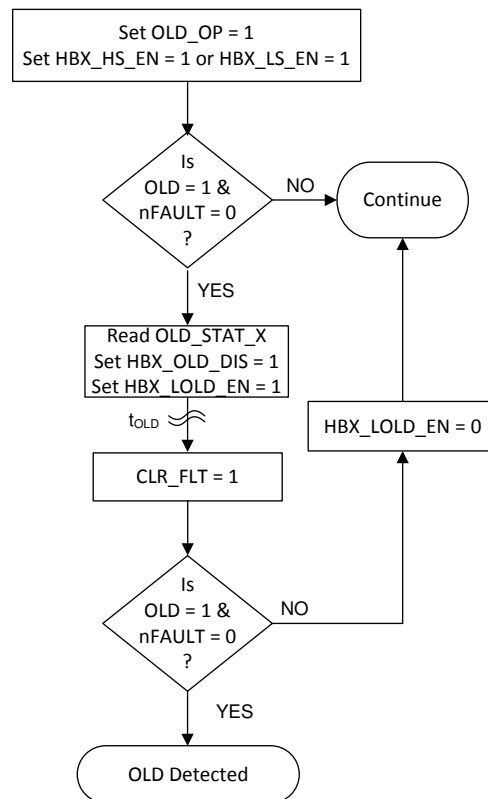

Figure 65. Flowchart for Enabling Low-Current OLD (Continuous Mode)

8.3.3.5.3 Passive OLD

In passive OLD, the detection of open load is carried before the driver is turned on. The state of all FETs remains in Hi-Z state, while a minimal amount of current flows through motor for short amount of time to test the motor connection. The diagnostic current is very small to avoid causing the motor rotation.

Figure 66, Figure 67, and Figure 68 show the circuit implementations of passive OLD. As shown in these figures, a constant current source pulls the OUT1 pin to the AVDD (internal fixed voltage) which allows current flow from OUT1 to OUT2 terminal. The current drawn is completely dependent on the motor resistance between OUT1 and OUT2 and limited by the internal current sourcing (I_{OL_PU}) and sinking (I_{OL_PD}) capability of the passive OLD circuitry. Depending on this current and the comparator threshold voltage (V_{OL_HS} and V_{OL_LS}), the comparator output OL1_HS and OL2_LS are either set or reset which determines the open-load status. When an open load is detected, the OLD bit in the IC status (IC_STAT) register is set, the HBX_LS_OLD bit in the open-load status register (OLD_STAT_X) is set and nFAULT pin is driven low. The OLD bit remains set until cleared through the CLR_FLT bit. This implementation is applicable for half-bridge driving as shown in Figure 67, and Figure 68.

NOTE

Passive OLD sequence is not disabled by the HBX_OLD_DIS bits.

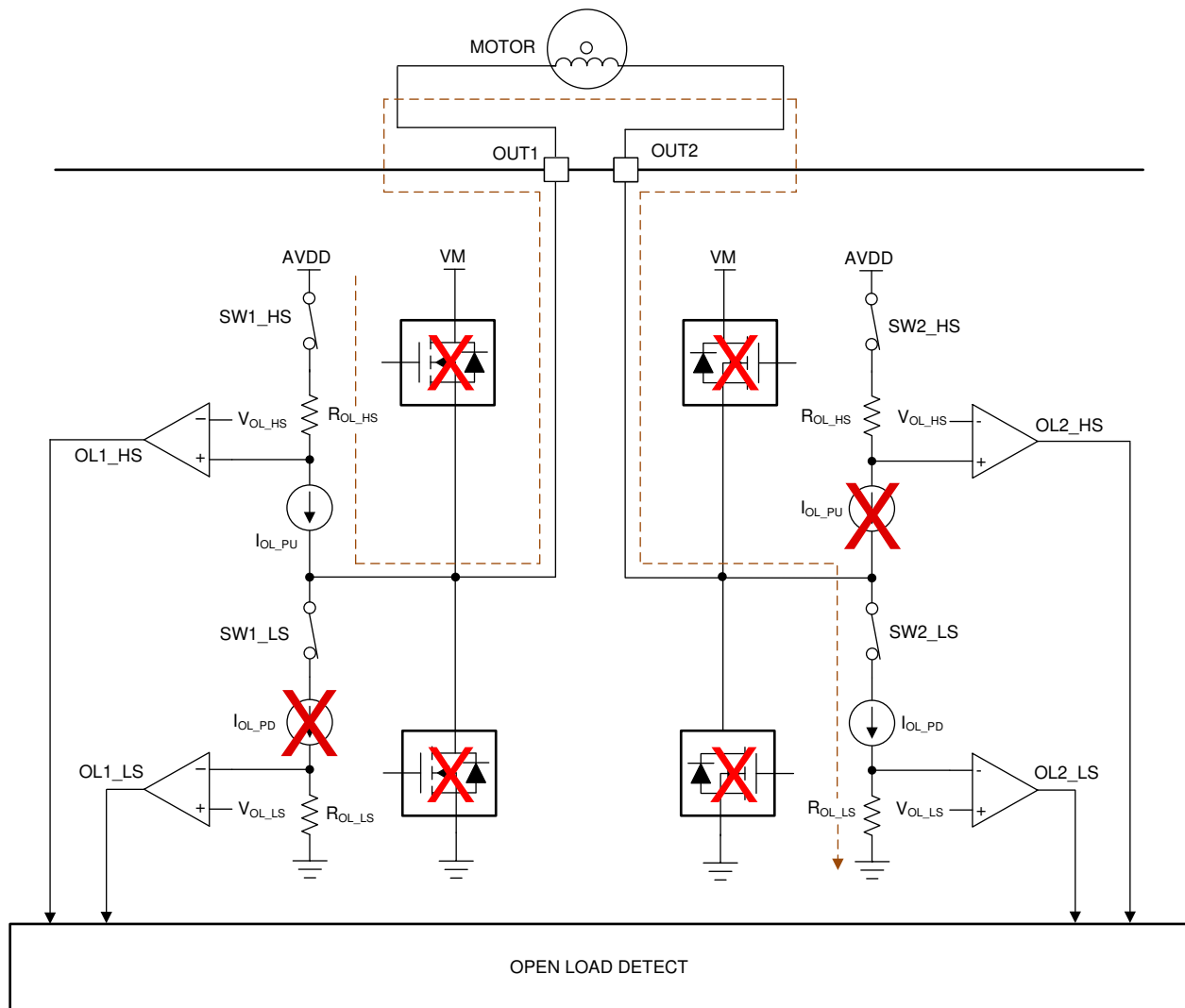

Figure 66. Passive OLD Circuit for a Load Driven in Full-Bridge Operation

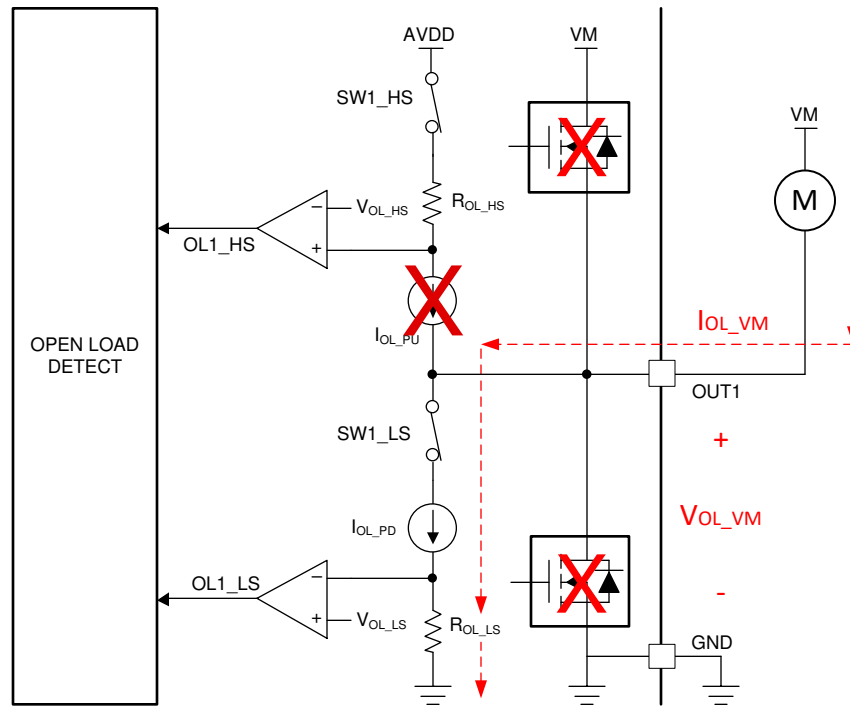

Figure 67. Passive OLD Circuit for Half-Bridge Operation with Load Connected to VM

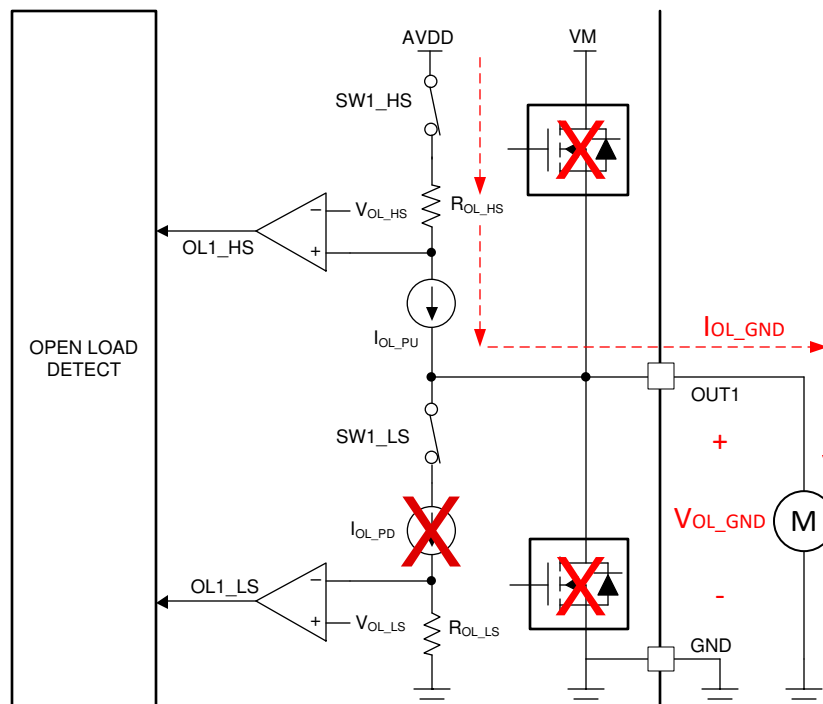

Figure 68. Passive OLD Circuit for Half-Bridge Operation with Load Connected to GND

Following are the steps to configure and detect the passive OLD in the DRV89XX-Q1 device.

1. Enable the passive OLD mode for the individual half-bridges which is to be diagnosed using the Half-bridge passive OLD enable bits (HBX_POLD_EN) in OLD_CTRL_5 register.
2. Configure the half-bridge operation control bits (HBX_HS_EN/HBX_LS_EN) in operation control register

(OP_CTRL_X) to determine the high-side and low-side OLD check. Note that these bits are now used for the passive OLD configuration. If anytime, the HBX_POLD_EN is reset then the bridge starts operating.

3. Enable the passive OLD using the Passive OLD Enable bit (POLD_EN) in CONFIG_CTRL register. Setting the POLD_EN bit enables the passive OLD detection circuit on all OUTx pin for which the corresponding HBX_HS_EN or HBX_LS_EN are set to 1.
4. Wait for the passive OLD time as determined by the user.
5. After the completion of passive OLD time, disable the passive OLD enable bit (POLD_EN).
6. Monitor the nFAULT pin / OLD bit in Status register (IC_STAT) and the HBX_HS_OLD/HBX_LS_OLD bit in the OLD status registers (OLD_STAT_X) for any open-load detection.
7. Restart the sequence for other half-bridges / full-bridges.

During normal driving, HBX_HS_EN and HBX_LS_EN bits control the state of OUTX. However, when POLD_EN and HBX_POLD_EN are 1, the OUTX channel is disabled, and HBX_HS_EN and HBX_LS_EN control SWX_HS and SWX_LS used for passive OLD (see schematic representation in [Figure 66](#)). [Table 9](#) shows the truth table for this operation.

Table 9. Truth Table for Passive OLD

HBX_POLD_EN	HBX_HS_EN	HBX_LS_EN	OUTX	SWX_HS	SWX_LS	OPEN LOAD SEQUENCE
0	X	X	Follows HBX_HS_EN and HBX_LS_EN	Open	Open	Passive OLD for the channel is disabled and HBX_HS_EN/HBX_LS_EN set output OUTx state
1	0	0	Z	Open	Open	Off state - no passive OLD
1	0	1	Z	Open	Closed	Valid passive OLD for VM-connected load
1	1	0	Z	Closed	Open	Valid passive OLD for GND-connected load
1	1	1	Z	Open	Open	Invalid state

NOTE

The OLD_REP bit works in a similar way as for the active OLD. The OLD_OP bit is not applicable for passive OLD operation since the outputs are already disabled.

NOTE

Passive OLD sequence is not enabled if any other fault (other than OCP/OLD) is present.

[Table 10](#) shows an example for configuring passive OLD for various loads. The HBX_VM_POLD bits can be enabled for any loads that connect directly to VM. In cases where VM is low, the passive OLD current may need to be larger so passive OLD does not falsely indicate an open load. Setting HBX_VM_POLD = 1 chooses a smaller R_{OL} so more current flows and the device can properly detect an open load.

Table 10. Passive OLD Configurations

CONNECTION	HB1_VM_POLD	HB2_VM_POLD	HB1_HS_EN	HB1_LS_EN	HB2_HS_EN	HB2_LS_EN	OPEN-LOAD DETECTION
Full-Bridge Operation (Motor Connected Between OUT1 and OUT2)	0	0	1	0	0	1	Detection based on resistance threshold (Forward Connection)
	0	0	0	1	1	0	Detection based on resistance threshold (Reverse Connection)
	0	0	1	0	1	0	Invalid case (both high-side OLD circuitry operating)
	0	0	0	1	0	1	Invalid case (both low-side OLD circuitry operating)
Half-Bridge Operation (Load Connected Between OUT1/2 and VM)	1	X	0	1	0	0	Detection only for OUT1 channel based on resistance threshold
	X	1	0	0	0	1	Detection only for OUT2 channel based on resistance threshold
	1	1	0	1	0	1	Detection for both outputs based on resistance threshold
	X	X	1	0	0	0	Invalid case (OUT1 high-side OLD circuitry is operating for VM connected load)
	X	X	0	0	1	0	Invalid case (OUT2 high-side OLD circuitry is operating for VM connected load)
	X	X	1	0	1	0	Invalid case (both high-side OLD circuitry is operating for VM connected load)
Half-Bridge Operation (Load Connected Between OUT1/2 and GND)	0	0	1	0	0	0	Detection only for OUT1 channel based on resistance threshold
	0	0	0	0	1	0	Detection only for OUT2 channel based on resistance threshold
	0	0	1	0	1	0	Detection for both outputs based on resistance threshold
	0	0	0	1	0	0	Invalid case (OUT1 low-side OLD circuitry is operating for GND connected load)
	0	0	0	0	0	1	Invalid case (OUT2 low-side OLD circuitry is operating for GND connected load)
	0	0	0	1	0	1	Invalid case (both low-side OLD circuitry is operating for GND connected load)

8.3.3.6 Thermal Warning (OTW)

If the die temperature exceeds the trip point of the thermal warning (T_{OTW}), the OTW bit is set in the IC status (IC_STAT) register. The reporting of OTW on the nFAULT pin can be enabled by setting the over-temperature warning reporting (OTW_REP) bit in the configuration control (CONFIG_CTRL) register. The device performs no additional action and continues to function. In this case, the nFAULT pin releases when the die temperature decreases below the hysteresis point of the thermal warning (T_{OTW_HYS}). The OTW bit remains set until cleared through the CLR_FLT bit and the die temperature is lower than thermal warning trip (T_{OTW}).

NOTE

Over Temperature warning is not reported on nFAULT pin by default.

8.3.3.7 Thermal Shutdown (OTSD)

If the die temperature exceeds the trip point of the thermal shutdown limit (T_{OTSD}), all half-bridge drivers are disabled, the charge pump is shut down, and the nFAULT pin is driven low. In addition, the OTSD bit is latched high in IC status (IC_STAT) register. Normal operation resumes (driver operation and the nFAULT pin is released) when the overtemperature shutdown condition is removed and die temperature decreases below the hysteresis point of the thermal warning (T_{OTSD_HYS}). The OTSD bit remains latched high indicating that a thermal event occurred until a clear fault command is issued through the CLR_FLT bit. This protection feature cannot be disabled.

8.4 Device Functional Modes

8.4.1 Sleep Mode (nSLEEP = 0)

The nSLEEP pin manages the state of the DRV89xx-Q1 device. When the nSLEEP pin is low, the device enters a low-power sleep mode. In sleep mode, all half-bridge drivers are disabled, the internal charge pump is disabled, the internal regulators are disabled, and the SPI bus is disabled. The t_{SLEEP} time must elapse after a falling edge on the nSLEEP pin before the device enters sleep mode. The device comes out of sleep mode automatically if the nSLEEP pin is pulled high. The t_{WAKE} time must elapse before the device is ready for inputs.

8.4.2 Operating Mode (nSLEEP = 1)

When the nSLEEP pin is high and $V_{VM} > V_{UVLO}$, the device enters operating mode. The t_{WAKE} time must elapse before the device is ready for inputs. In this mode the half bridge drivers, charge pump, internal regulators, and SPI bus are active. [Table 11](#) summarizes the different operating modes of DRV89XX-Q1 device.

Table 11. Functional Modes

MODE	CONDITION	HALF-BRIDGES	INTERNAL CIRCUITS
Operating	4.5-V < V_{VM} < 20-V (EXT_OVP = 0b) 4.5-V < V_{VM} < 32-V (EXT_OVP = 1b) nSLEEP Pin = High	Operating	Operating
Sleep	4.5-V < V_{VM} < 32-V nSLEEP Pin = Low	Disabled	Disabled
Fault	Any Fault Condition Met	Depends on Fault	Depends on Fault

8.4.3 Fault Mode

The DRV89XX-Q1 is protected against various faults as summarized in [Table 12](#).

Table 12. Fault Action and Response

FAULT	CONDITION	CONFIGURATION	REPORT	HALF-BRIDGE	LOGIC	RECOVERY
VM Undervoltage (UVLO)	$V_{VM} < V_{UVLO}$ (Max. 4.5-V)	—	nFAULT Pin IC_STAT Register	Hi-Z	Active	Automatic: $V_{VM} > V_{UVLO}$
VDD Undervoltage (UVLO)	$V_{VDD} < V_{POR}$ (Max 3-V)	—	IC_STAT Register	Hi-Z	Reset	Automatic: $V_{VDD} > V_{POR}$
VM Overvoltage (OVP)	$V_{VM} > V_{OVP}$ (Min. 20-V)	EXT_OVP = 0	nFAULT Pin IC_STAT Register	Hi-Z	Active	Automatic: $V_{VM} < V_{OVP}$
		EXT_OVP = 1				
Over Current Protection (OCP)	$I_{OUT} > I_{OCP}$ (Min. 1.3-A)	OCP_REP = 0	IC_STAT Register	Hi-Z	Active	CLR_FLT = 1 & $I_{OUT} < I_{OCP}$
		OCP_REP = 1	nFAULT Pin IC_STAT Register	Hi-Z	Active	
Open-Load Detect (OLD)	$I_{OUT} < I_{OLD}$ (Max. 15-mA)	OLD_OP = 0 OLD_REP = 0	nFAULT Pin IC_STAT Register	Hi-Z	Active	CLR_FLT = 1 & $I_{LOAD} > I_{OLD}$
		OLD_OP = 0 OLD_REP = 1	IC_STAT Register	Hi-Z	Active	
		OLD_OP = 1 OLD_REP = 0	nFAULT Pin IC_STAT Register	Operating	Active	
		OLD_OP = 1 OLD_REP = 1	IC_STAT Register	Operating	Active	
	$R_{LOAD} > R_{OLD}$ (Max. 100-k Ω)	OLD_REP = 0	nFAULT Pin IC_STAT Register	N/A	Active	CLR_FLT = 1 & OLD Sequenced & $R_{LOAD} < R_{OLD}$
		OLD_REP = 1	IC_STAT Register	N/A	Active	
Over-Temperature Warning (OTW)	$T_J > T_{OTW}$ (Min. 120°C)	OTW_REP = 0	IC_STAT Register	Operating	Active	No Action
		OTW_REP = 1	nFAULT Pin IC_STAT Register	Operating	Active	Automatic: $T_J < T_{OTW}$ $-T_{OTW_HYS}$

Table 12. Fault Action and Response (continued)

FAULT	CONDITION	CONFIGURATION	REPORT	HALF-BRIDGE	LOGIC	RECOVERY
Over-Temperature Shutdown (OTSD)	$T_J > T_{OTSD}$ (Min. 150°C)	—	nFAULT Pin IC_STAT Register	Hi-Z	Active	Automatic: $T_J < T_{OTSD} - T_{OTSD_HYS}$

8.5 Programming

8.5.1 SPI

SPI bus is used to set device configurations, operating parameters, and read out diagnostic information on the DRV89xx-Q1 device. The SPI operates in slave mode and connects to a master controller. The SPI input data (SDI) word consists of a 16 bit word, with an 8-bit command and 8 bits of data. The SPI output data (SDO) word consists of 8-bit register data and the first 8 bits make up the Status Register with Fault Status indication. The data sequence between the MCU and the SPI slave driver is shown in [Figure 69](#).

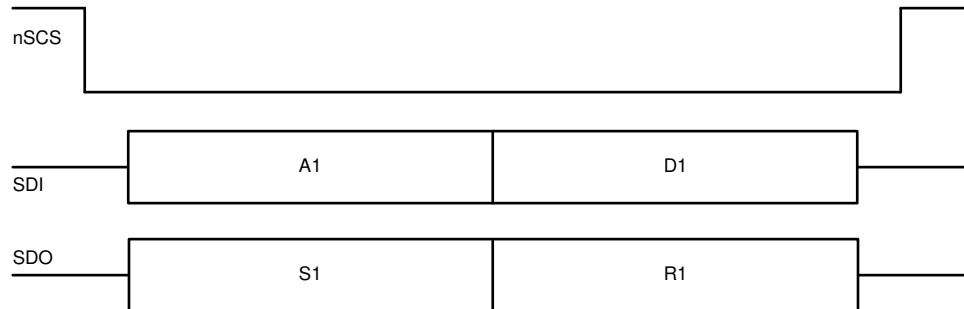

Figure 69. SPI Data Frame

A valid frame must meet the following conditions:

- The SCLK pin should be low when the nSCS pin transitions from high to low and from low to high.
- The nSCS pin should be pulled high for at least 400 ns between words.
- When the nSCS pin is pulled high, any signals at the SCLK and SDI pins are ignored and the SDO pin is placed in the Hi-Z state.
- Data is captured on the falling edge of SCLK and data is propagated on the rising edge of SCLK.
- The most significant bit (MSB) is shifted in and out first.
- A full 16 SCLK cycles must occur for transaction to be valid.
- If the data word sent to the SDI pin is less than or more than 16 bits, a frame error occurs and the data word is ignored.
- For a write command, the existing data in the register being written to is shifted out on the SDO pin following the 8-bit command data.

8.5.2 SPI Format

The SDI input data word is 16 bits long and consists of the following format:

- 1 read or write bit, W (bit B14)
- 6 address bits, A (bits B13 through B8)
- 8 data bits, D (bits B7 through B0)

The SDO output data word is 16 bits long and the first 8 bits makes up the IC status register. The report word is the content of the register being accessed.

For a write command ($W0 = 0$), the response word on the SDO pin is the data currently in the register being written to.

For a read command ($W0 = 1$), the response word is the data currently in the register being read.

Programming (continued)

Table 13. SDI Input Data Word Format

	R/W	Address							Data							
Bit	B15	B14	B13	B12	B11	B10	B9	B8	B7	B6	B5	B4	B3	B2	B1	B0
Data	0	W0	A5	A4	A3	A2	A1	A0	D7	D6	D5	D4	D3	D2	D1	D0

Table 14. SDO Output Data Word Format

	IC Status							Report								
Bit	B15	B14	B13	B12	B11	B10	B9	B8	B7	B6	B5	B4	B3	B2	B1	B0
Data	1	1	OT	OLD	OCF	UVLO	OVP	NPOR	D7	D6	D5	D4	D3	D2	D1	D0

8.5.3 SPI Interface for Multiple Slaves

Multiple DRV89XX-Q1 devices can be connected to the master controller with and without the daisy chain. For connecting a 'n' number of DRV89XX-Q1 to a master controller without using a daisy chain, 'n' number of I/O resources from master controller has to be utilized for nSCS pins as shown [Figure 70](#). Whereas, if the daisy chain configuration is used, then a single nSCS line can be used for connecting multiple DRV89XX-Q1 devices as shown in [Figure 71](#).

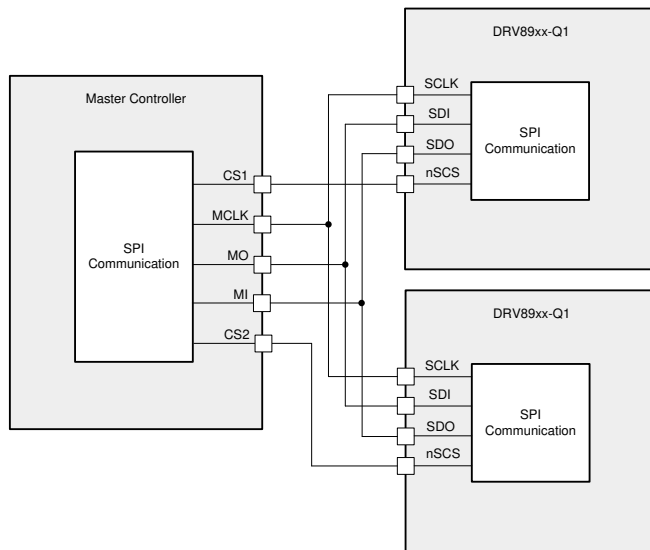

Figure 70. SPI Operation Without Daisy Chain

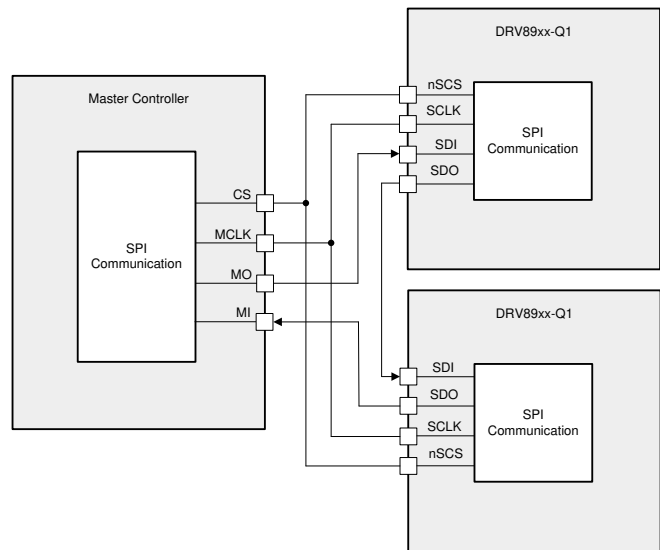

Figure 71. SPI Operation With Daisy Chain

8.5.3.1 SPI Interface for Multiple Slaves in Daisy Chain

The DRV89XX-Q1 device can be connected in a daisy chain configuration to save GPIO ports when multiple devices are communicating to the same MCU. Figure 72 shows the topology when 3 devices are connected in series with waveforms.

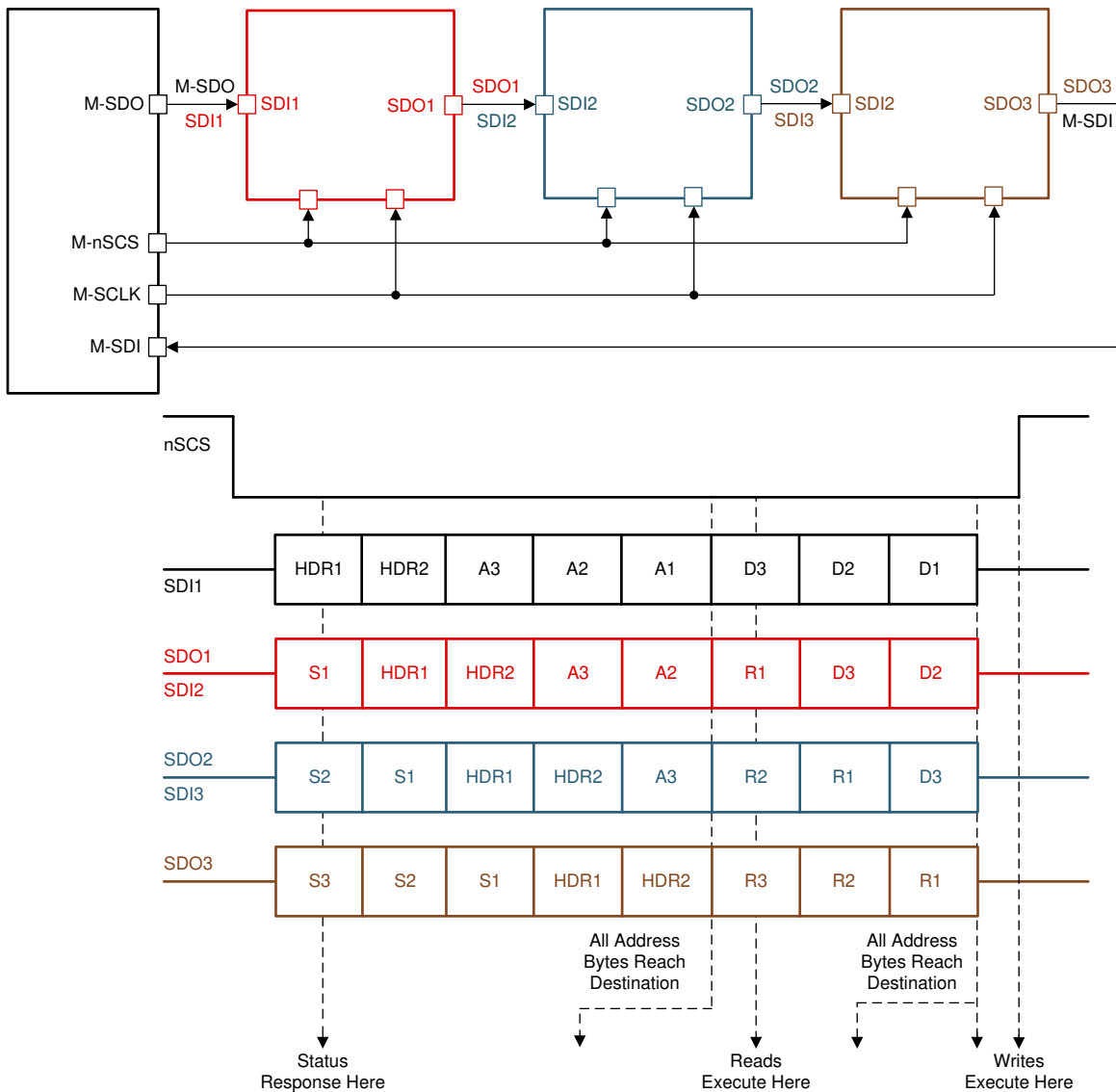

Figure 72. Daisy Chain SPI Operation

The first device in the chain shown above receives data from the master controller in the following format. See SDI1 in Figure 72

- 2 bytes of Header
- 3 bytes of Address
- 3 bytes of Data

After the data has been transmitted through the chain, the master controller receives it in the following format. See SDO3 in Figure 72

- 3 bytes of Status
- 2 bytes of Header (should be identical to the information controller sent)
- 3 bytes of Report

The Header bytes contain information of the number of devices connected in the chain, and a global clear fault command that will clear the fault registers of all the devices on the rising edge of the chip select (nSCS) signal. N5 through N0 are 6 bits dedicated to show the number of devices in the chain as shown in Figure 73. Up to 63 devices can be connected in series per daisy chain connection.

The 5 LSBs of the HDR2 register are don't care bits that can be used by the MCU to determine integrity of the daisy chain connection. Header bytes must start with 1 and 0 for the two MSBs.

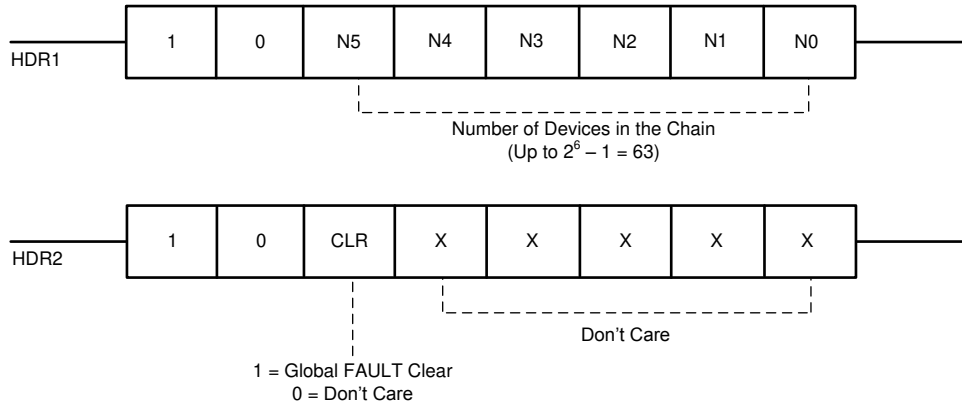

Figure 73. Header Bits

The Status byte provides information about the fault status register for each device in the daisy chain as shown in Figure 74. That way the master controller does not have to initiate a read command to read the fault status from any particular device. This saves the controller additional read commands and makes the system more efficient to determine fault conditions flagged in a device.

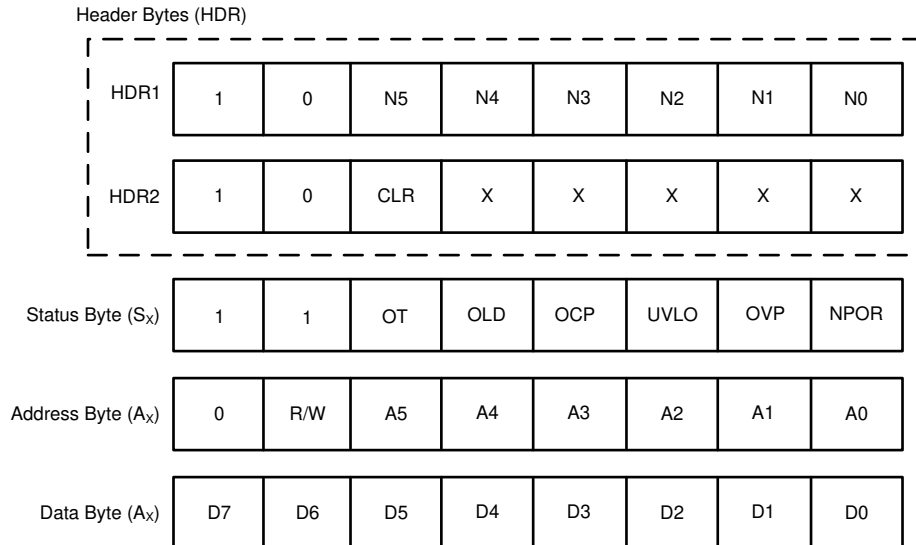

Figure 74. Daisy Chain Read Registers

When data passes through a device, it determines the position of itself in the chain by counting the number of Status bytes it receives following by the first Header byte. For example, in this 3 device configuration, device 2 in the chain will receive two Status bytes before receiving HDR1 byte, followed by HDR2 byte.

From the two Status bytes it knows that its position is second in the chain, and from HDR2 byte it knows how many devices are connected in the chain. That way it only loads the relevant address and data byte in its buffer and bypasses the other bits. This protocol allows for faster communication without adding latency to the system for up to 63 devices in the chain.

The address and data bytes remain the same with respect to a single device connection. The Report bytes (R1 through R3), as shown in the figure above, is the content of the register being accessed.

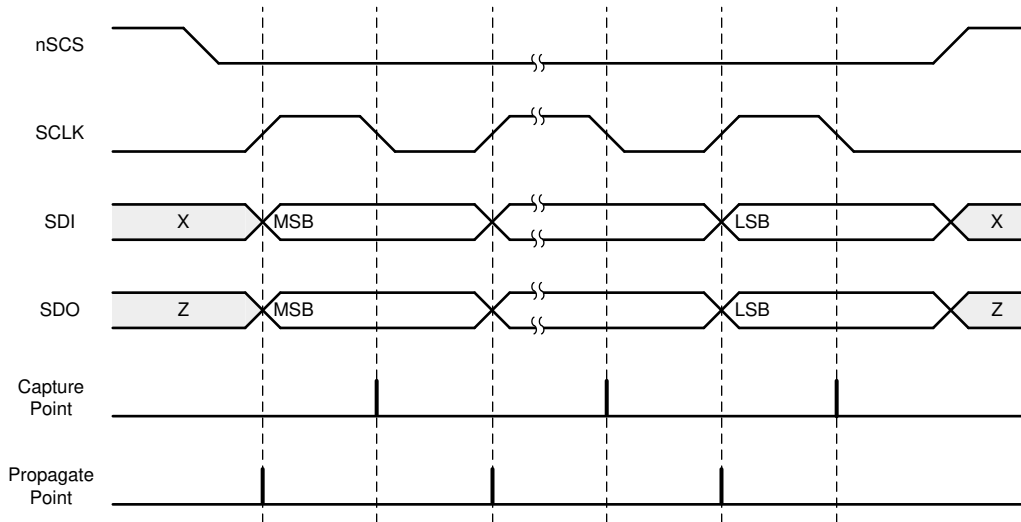

Figure 75. SPI Slave Timing Diagram

8.6 Register Map

This section contains the register maps and bit descriptions for all of the DRV89xx-Q1 devices. [DRV8912-Q1 and DRV8910-Q1 Register Maps](#) contains the register maps and register descriptions for DRV8912-Q1 and DRV8910-Q1 devices. [DRV8908-Q1, DRV8906-Q1 and DRV8904-Q1 Register Maps](#) contains the register maps and register descriptions for DRV8908-Q1, DRV8906-Q1, and DRV8904-Q1 devices. [Table 15](#) summarizes the differences among the part numbers in the DRV89xx-Q1 family.

Table 15. Summary of DRV89xx-Q1 Device Family

DEVICE	NUMBER OF HALF-BRIDGES	NUMBER OF PWM GENERATORS	OPEN-LOAD DETECTION SCHEMES	LINK TO REGISTER MAP
DRV8912-Q1	12	4	Active OLD, Low-Current Active OLD, Negative-Current Active OLD	Table 17
DRV8910-Q1	10	4		Table 18
DRV8908-Q1	8	8	Passive OLD, Active OLD, Low-Current Active OLD, Negative-Current Active OLD	Table 50
DRV8906-Q1	6	8		Table 51
DRV8904-Q1	4	8		Table 52

Complex bit access types are encoded to fit into small table cells. [Table 16](#) shows the codes that are used for access types in this section.

Table 16. Control Registers Access Type Codes

Access Type	Code	Description
Read Type		
R	R	Read
Write Type		
W	W	Write
Reset or Default Value		
-n		Value after reset or the default value

8.6.1 DRV8912-Q1 and DRV8910-Q1 Register Maps

Table 17. DRV8912-Q1 Register Map

Name	7	6	5	4	3	2	1	0	Type	Address	
IC_STAT	Reserved	OTSD	OTW	OLD	OCP	UVLO	OVP	NPOR	R	00h	
OCP_STAT_1	HB4_HS_OCP	HB4_LS_OCP	HB3_HS_OCP	HB3_LS_OCP	HB2_HS_OCP	HB2_LS_OCP	HB1_HS_OCP	HB1_LS_OCP	R	01h	
OCP_STAT_2	HB8_HS_OCP	HB8_LS_OCP	HB7_HS_OCP	HB7_LS_OCP	HB6_HS_OCP	HB6_LS_OCP	HB5_HS_OCP	HB5_LS_OCP	R	02h	
OCP_STAT_3	HB12_HS_OCP	HB12_LS_OCP	HB11_HS_OCP	HB11_LS_OCP	HB10_HS_OCP	HB10_LS_OCP	HB9_HS_OCP	HB9_LS_OCP	R	03h	
OLD_STAT_1	HB4_HS_OLD	HB4_LS_OLD	HB3_HS_OLD	HB3_LS_OLD	HB2_HS_OLD	HB2_LS_OLD	HB1_HS_OLD	HB1_LS_OLD	R	04h	
OLD_STAT_2	HB8_HS_OLD	HB8_LS_OLD	HB7_HS_OLD	HB7_LS_OLD	HB6_HS_OLD	HB6_LS_OLD	HB5_HS_OLD	HB5_LS_OLD	R	05h	
OLD_STAT_3	HB12_HS_OLD	HB12_LS_OLD	HB11_HS_OLD	HB11_LS_OLD	HB10_HS_OLD	HB10_LS_OLD	HB9_HS_OLD	HB9_LS_OLD	R	06h	
CONFIG_CTRL	Reserved	IC_ID			OCP_REP	OTW_REP	EXT_OVP	CLR_FLT	RW	07h	
OP_CTRL_1	HB4_HS_EN	HB4_LS_EN	HB3_HS_EN	HB3_LS_EN	HB2_HS_EN	HB2_LS_EN	HB1_HS_EN	HB1_LS_EN	RW	08h	
OP_CTRL_2	HB8_HS_EN	HB8_LS_EN	HB7_HS_EN	HB7_LS_EN	HB6_HS_EN	HB6_LS_EN	HB5_HS_EN	HB5_LS_EN	RW	09h	
OP_CTRL_3	HB12_HS_EN	HB12_LS_EN	HB11_HS_EN	HB11_LS_EN	HB10_HS_EN	HB10_LS_EN	HB9_HS_EN	HB9_LS_EN	RW	0Ah	
PWM_CTRL_1	HB8_PWM	HB7_PWM	HB6_PWM	HB5_PWM	HB4_PWM	HB3_PWM	HB2_PWM	HB1_PWM	RW	0Bh	
PWM_CTRL_2	PWM_CH4_DIS	PWM_CH3_DIS	PWM_CH2_DIS	PWM_CH1_DIS	HB12_PWM	HB11_PWM	HB10_PWM	HB9_PWM	RW	0Ch	
FW_CTRL_1	HB8_FW	HB7_FW	HB6_FW	HB5_FW	HB4_FW	HB3_FW	HB2_FW	HB1_FW	RW	0Dh	
FW_CTRL_2	Reserved				HB12_FW	HB11_FW	HB10_FW	HB9_FW	RW	0Eh	
PWM_MAP_CTRL_1	HB4_PWM_MAP		HB3_PWM_MAP		HB2_PWM_MAP		HB1_PWM_MAP		RW	0Fh	
PWM_MAP_CTRL_2 ⁽¹⁾	HB8_PWM_MAP		HB7_PWM_MAP		HB6_PWM_MAP		HB5_PWM_MAP		RW	10h ⁽¹⁾	
PWM_MAP_CTRL_3	HB12_PWM_MAP		HB11_PWM_MAP		HB10_PWM_MAP		HB9_PWM_MAP		RW	11h	
PWM_FREQ_CTRL	PWM_CH4_FREQ		PWM_CH3_FREQ		PWM_CH2_FREQ		PWM_CH1_FREQ		RW	12h	
PWM_DUTY_CTRL_1	PWM_DUTY_CH1									RW	13h
PWM_DUTY_CTRL_2	PWM_DUTY_CH2									RW	14h
PWM_DUTY_CTRL_3	PWM_DUTY_CH3									RW	15h
PWM_DUTY_CTRL_4	PWM_DUTY_CH4									RW	16h
SR_CTRL_1	HB8_SR	HB7_SR	HB6_SR	HB5_SR	HB4_SR	HB3_SR	HB2_SR	HB1_SR	RW	17h	
SR_CTRL_2	Reserved				HB12_SR	HB11_SR	HB10_SR	HB9_SR	RW	18h	
OLD_CTRL_1	HB8_OLD_DIS	HB7_OLD_DIS	HB6_OLD_DIS	HB5_OLD_DIS	HB4_OLD_DIS	HB3_OLD_DIS	HB2_OLD_DIS	HB1_OLD_DIS	RW	19h	
OLD_CTRL_2	OLD_REP	OLD_OP	PL_MODE_EN		HB12_OLD_DIS	HB11_OLD_DIS	HB10_OLD_DIS	HB9_OLD_DIS	RW	1Ah	
OLD_CTRL_3	OCP_DEG			OLD_NEG_EN	HB12_LOLD_EN	HB11_LOLD_EN	HB10_LOLD_EN	HB9_LOLD_EN	RW	1Bh	
OLD_CTRL_4	HB8_LOLD_EN	HB7_LOLD_EN	HB6_LOLD_EN	HB5_LOLD_EN	HB4_LOLD_EN	HB3_LOLD_EN	HB2_LOLD_EN	HB1_LOLD_EN	RW	24h	

(1) After this register address, the functions are similar between DRV8912-Q1 and DRV8910-Q1. However, DRV8908-Q1, DRV8906-Q1, and DRV8904-Q1 have different functions for these addresses.

Table 18. DRV8910-Q1 Register Map

Name	7	6	5	4	3	2	1	0	Type	Address
IC_STAT	Reserved	OTSD	OTW	OLD	OCP	UVLO	OVP	NPOR	R	00h
OCP_STAT_1	HB4_HS_OCP	HB4_LS_OCP	HB3_HS_OCP	HB3_LS_OCP	HB2_HS_OCP	HB2_LS_OCP	HB1_HS_OCP	HB1_LS_OCP	R	01h
OCP_STAT_2	HB8_HS_OCP	HB8_LS_OCP	HB7_HS_OCP	HB7_LS_OCP	HB6_HS_OCP	HB6_LS_OCP	HB5_HS_OCP	HB5_LS_OCP	R	02h
OCP_STAT_3	Reserved				HB10_HS_OCP	HB10_LS_OCP	HB9_HS_OCP	HB9_LS_OCP	R	03h
OLD_STAT_1	HB4_HS_OLD	HB4_LS_OLD	HB3_HS_OLD	HB3_LS_OLD	HB2_HS_OLD	HB2_LS_OLD	HB1_HS_OLD	HB1_LS_OLD	R	04h
OLD_STAT_2	HB8_HS_OLD	HB8_LS_OLD	HB7_HS_OLD	HB7_LS_OLD	HB6_HS_OLD	HB6_LS_OLD	HB5_HS_OLD	HB5_LS_OLD	R	05h
OLD_STAT_3	Reserved				HB10_HS_OLD	HB10_LS_OLD	HB9_HS_OLD	HB9_LS_OLD	R	06h
CONFIG_CTRL	Reserved	IC_ID			OCP_REP	OTW_REP	EXT_OVP	CLR_FLT	RW	07h
OP_CTRL_1	HB4_HS_EN	HB4_LS_EN	HB3_HS_EN	HB3_LS_EN	HB2_HS_EN	HB2_LS_EN	HB1_HS_EN	HB1_LS_EN	RW	08h
OP_CTRL_2	HB8_HS_EN	HB8_LS_EN	HB7_HS_EN	HB7_LS_EN	HB6_HS_EN	HB6_LS_EN	HB5_HS_EN	HB5_LS_EN	RW	09h
OP_CTRL_3	Reserved				HB10_HS_EN	HB10_LS_EN	HB9_HS_EN	HB9_LS_EN	RW	0Ah
PWM_CTRL_1	HB8_PWM	HB7_PWM	HB6_PWM	HB5_PWM	HB4_PWM	HB3_PWM	HB2_PWM	HB1_PWM	RW	0Bh
PWM_CTRL_2	PWM_CH4_DIS	PWM_CH3_DIS	PWM_CH2_DIS	PWM_CH1_DIS	Reserved		HB10_PWM	HB9_PWM	RW	0Ch
FW_CTRL_1	HB8_FW	HB7_FW	HB6_FW	HB5_FW	HB4_FW	HB3_FW	HB2_FW	HB1_FW	RW	0Dh
FW_CTRL_2	Reserved						HB10_FW	HB9_FW	RW	0Eh
PWM_MAP_CTRL_1	HB4_PWM_MAP		HB3_PWM_MAP		HB2_PWM_MAP		HB1_PWM_MAP		RW	0Fh
PWM_MAP_CTRL_2 ⁽¹⁾	HB8_PWM_MAP		HB7_PWM_MAP		HB6_PWM_MAP		HB5_PWM_MAP		RW	10h ⁽¹⁾
PWM_MAP_CTRL_3	Reserved				HB10_PWM_MAP		HB9_PWM_MAP		RW	11h
PWM_FREQ_CTRL	PWM_CH4_FREQ		PWM_CH3_FREQ		PWM_CH2_FREQ		PWM_CH1_FREQ		RW	12h
PWM_DUTY_CTRL_1	PWM_DUTY_CH1								RW	13h
PWM_DUTY_CTRL_2	PWM_DUTY_CH2								RW	14h
PWM_DUTY_CTRL_3	PWM_DUTY_CH3								RW	15h
PWM_DUTY_CTRL_4	PWM_DUTY_CH4								RW	16h
SR_CTRL_1	HB8_SR	HB7_SR	HB6_SR	HB5_SR	HB4_SR	HB3_SR	HB2_SR	HB1_SR	RW	17h
SR_CTRL_2	Reserved						HB10_SR	HB9_SR	RW	18h
OLD_CTRL_1	HB8_OLD_DIS	HB7_OLD_DIS	HB6_OLD_DIS	HB5_OLD_DIS	HB4_OLD_DIS	HB3_OLD_DIS	HB2_OLD_DIS	HB1_OLD_DIS	RW	19h
OLD_CTRL_2	OLD_REP	OLD_OP	PL_MODE_EN		Reserved		HB10_OLD_DIS	HB9_OLD_DIS	RW	1Ah
OLD_CTRL_3	OCP_DEG			OLD_NEG_EN	Reserved		HB10_LOLD_EN	HB9_LOLD_EN	RW	1Bh
OLD_CTRL_4	HB8_LOLD_EN	HB7_LOLD_EN	HB6_LOLD_EN	HB5_LOLD_EN	HB4_LOLD_EN	HB3_LOLD_EN	HB2_LOLD_EN	HB1_LOLD_EN	RW	24h

(1) After this register address, the register functions are similar between DRV8912-Q1 and DRV8910-Q1. However, DRV8908-Q1, DRV8906-Q1, and DRV8904-Q1 have different functions for these addresses.

8.6.1.1 Status Registers

The status registers are used to report warning and fault conditions. The status registers are read-only registers.

Table 19 lists the memory-mapped registers for the status registers. All register offset addresses not listed in Table 19 should be considered as reserved locations and the register contents should not be modified.

Table 19. Status Registers Summary Table

Address	Register Name	Section
0x00	IC Status	Go
0x01	Overcurrent Protection (OCP) Status 1	Go
0x02	Overcurrent Protection (OCP) Status 2	Go
0x03	Overcurrent Protection (OCP) Status 3	Go
0x04	Open-Load Detect (OLD) Status 1	Go
0x05	Open-Load Detect (OLD) Status 2	Go
0x06	Open-Load Detect (OLD) Status 3	Go

8.6.1.1.1 IC Status (IC_STAT) Register (Address = 0x00) [reset = 0x00]

The IC status (IC_STAT) register is shown in Figure 76 and described in Table 20.

Register access type: Read only

Figure 76. IC Status Register

7	6	5	4	3	2	1	0
Reserved	OTSD	OTW	OLD	OCP	UVLO	OVP	NPOR
R-0b	R-0b	R-0b	R-0b	R-0b	R-0b	R-0b	R-0b

Table 20. IC Status Register Field Descriptions

Bit	Field	Type	Default	Description
7	Reserved	R	0b	Reserved
6	OTSD	R	0b	0b = No overtemperature shutdown is detected 1b = Overcurrent condition is detected
5	OTW	R	0b	0b = No overtemperature warning is detected 1b = Overcurrent condition is detected
4	OLD	R	0b	0b = No open-load condition is detected 1b = Open-load condition is detected
3	OCP	R	0b	0b = No overcurrent condition is detected 1b = Overcurrent condition is detected
2	UVLO	R	0b	0b = No undervoltage lock-out condition is detected 1b = Under-voltage lock-out condition condition is detected
1	OVP	R	0b	0b = No overvoltage condition is detected 1b = Overvoltage condition is detected
0	NPOR	R	0b	0b = Power-on-reset condition is detected 1b = No power-on-reset condition is detected

8.6.1.1.2 Overcurrent Protection (OCP) Status 1 (OCP_STAT_1) Register (Address = 0x01) [reset = 0x00]

 The overcurrent protection (OCP) status 1 register is shown in [Figure 77](#) and described in [Table 21](#).

Register access type: Read only

Figure 77. Overcurrent Protection (OCP) Status 1 Register

7	6	5	4	3	2	1	0
HB4_HS_OCP	HB4_LS_OCP	HB3_HS_OCP	HB3_LS_OCP	HB2_HS_OCP	HB2_LS_OCP	HB1_HS_OCP	HB1_LS_OCP
R-0b	R-0b	R-0b	R-0b	R-0b	R-0b	R-0b	R-0b

Table 21. Overcurrent Protection (OCP) Status 1 Register Field Descriptions

Bit	Field	Type	Default	Description
7	HB4_HS_OCP	R	0b	0b = No overcurrent detected on high-side switch of half-bridge 4 1b = Overcurrent detected on high-side switch of half-bridge 4
6	HB4_LS_OCP	R	0b	0b = No overcurrent detected on low-side switch of half-bridge 4 1b = Overcurrent detected on low-side switch of half-bridge 4
5	HB3_HS_OCP	R	0b	0b = No overcurrent detected on high-side switch of half-bridge 3 1b = Overcurrent detected on high-side switch of half-bridge 3
4	HB3_LS_OCP	R	0b	0b = No overcurrent detected on low-side switch of half-bridge 3 1b = Overcurrent detected on low-side switch of half-bridge 3
3	HB2_HS_OCP	R	0b	0b = No overcurrent detected on high-side switch of half-bridge 2 1b = Overcurrent detected on high-side switch of half-bridge 2
2	HB2_LS_OCP	R	0b	0b = No overcurrent detected on low-side switch of half-bridge 2 1b = Overcurrent detected on low-side switch of half-bridge 2
1	HB1_HS_OCP	R	0b	0b = No overcurrent detected on high-side switch of half-bridge 1 1b = Overcurrent detected on high-side switch of half-bridge 1
0	HB1_LS_OCP	R	0b	0b = No overcurrent detected on low-side switch of half-bridge 1 1b = Overcurrent detected on low-side switch of half-bridge 1

8.6.1.1.3 Overcurrent Protection (OCP) Status 2 (OCP_STAT_2) Register (Address = 0x02) [reset = 0x00]

The overcurrent protection (OCP) status 2 register is shown in [Figure 78](#) and described in [Table 22](#).

Register access type: Read only

Figure 78. Overcurrent Protection (OCP) Status 2 Register

7	6	5	4	3	2	1	0
HB8_HS_OCP	HB8_LS_OCP	HB7_HS_OCP	HB7_LS_OCP	HB6_HS_OCP	HB6_LS_OCP	HB5_HS_OCP	HB5_LS_OCP
R-0b	R-0b	R-0b	R-0b	R-0b	R-0b	R-0b	R-0b

Table 22. Overcurrent Protection (OCP) Status 2 Register Field Descriptions

Bit	Field	Type	Default	Description
7	HB8_HS_OCP	R	0b	0b = No overcurrent detected on high-side switch of half-bridge 8 1b = Overcurrent detected on high-side switch of half-bridge 8
6	HB8_LS_OCP	R	0b	0b = No overcurrent detected on low-side switch of half-bridge 8 1b = Overcurrent detected on low-side switch of half-bridge 8
5	HB7_HS_OCP	R	0b	0b = No overcurrent detected on high-side switch of half-bridge 7 1b = Overcurrent detected on high-side switch of half-bridge 7
4	HB7_LS_OCP	R	0b	0b = No overcurrent detected on low-side switch of half-bridge 7 1b = Overcurrent detected on low-side switch of half-bridge 7
3	HB6_HS_OCP	R	0b	0b = No overcurrent detected on high-side switch of half-bridge 6 1b = Overcurrent detected on high-side switch of half-bridge 6
2	HB6_LS_OCP	R	0b	0b = No overcurrent detected on low-side switch of half-bridge 6 1b = Overcurrent detected on low-side switch of half-bridge 6
1	HB5_HS_OCP	R	0b	0b = No overcurrent detected on high-side switch of half-bridge 5 1b = Overcurrent detected on high-side switch of half-bridge 5
0	HB5_LS_OCP	R	0b	0b = No overcurrent detected on low-side switch of half-bridge 5 1b = Overcurrent detected on low-side switch of half-bridge 5

8.6.1.1.4 Overcurrent Protection (OCP) Status 3 (OCP_STAT_3) Register (Address = 0x03) [reset = 0x00]

 The overcurrent protection (OCP) status 3 register is shown in [Figure 79](#) and described in [Table 23](#).

Register access type: Read only

Figure 79. Overcurrent Protection (OCP) Status 3 Register

7	6	5	4	3	2	1	0
HB12_HS_OCP	HB12_LS_OCP	HB11_HS_OCP	HB11_LS_OCP	HB10_HS_OCP	HB10_LS_OCP	HB9_HS_OCP	HB9_LS_OCP
P		P		P			
R-0b	R-0b	R-0b	R-0b	R-0b	R-0b	R-0b	R-0b

Table 23. Overcurrent Protection (OCP) Status 3 Register Field Descriptions

Bit	Field	Type	Default	Description
7	HB12_HS_OCP	R	0b	0b = No overcurrent detected on high-side switch of half-bridge 12 1b = Overcurrent detected on high-side switch of half-bridge 12
6	HB12_LS_OCP	R	0b	0b = No overcurrent detected on low-side switch of half-bridge 12 1b = Overcurrent detected on low-side switch of half-bridge 12
5	HB11_HS_OCP	R	0b	0b = No overcurrent detected on high-side switch of half-bridge 11 1b = Overcurrent detected on high-side switch of half-bridge 11
4	HB11_LS_OCP	R	0b	0b = No overcurrent detected on low-side switch of half-bridge 11 1b = Overcurrent detected on low-side switch of half-bridge 11
3	HB10_HS_OCP	R	0b	0b = No overcurrent detected on high-side switch of half-bridge 10 1b = Overcurrent detected on high-side switch of half-bridge 10
2	HB10_LS_OCP	R	0b	0b = No overcurrent detected on low-side switch of half-bridge 10 1b = Overcurrent detected on low-side switch of half-bridge 10
1	HB9_HS_OCP	R	0b	0b = No overcurrent detected on high-side switch of half-bridge 9 1b = Overcurrent detected on high-side switch of half-bridge 9
0	HB9_LS_OCP	R	0b	0b = No overcurrent detected on low-side switch of half-bridge 9 1b = Overcurrent detected on low-side switch of half-bridge 9

8.6.1.1.5 Open-Load Detect (OLD) Status 1 (OLD_STAT_1) Register (Address = 0x04) [reset = 0x00]

The open-load detect (OLD) status 1 register is shown in [Figure 80](#) and described in [Table 24](#).

Register access type: Read only

Figure 80. Open-Load Detect (OLD) Status 1 Register

7	6	5	4	3	2	1	0
HB4_HS_OLD	HB4_LS_OLD	HB3_HS_OLD	HB3_LS_OLD	HB2_HS_OLD	HB2_LS_OLD	HB1_HS_OLD	HB1_LS_OLD
R-0b	R-0b	R-0b	R-0b	R-0b	R-0b	R-0b	R-0b

Table 24. Open-Load Detect (OLD) Status 1 Register Field Descriptions

Bit	Field	Type	Default	Description
7	HB4_HS_OLD	R	0b	0b = No open load detected on high-side switch of half-bridge 4 1b = Open load detected on high-side switch of half-bridge 4
6	HB4_LS_OLD	R	0b	0b = No open load detected on low-side switch of half-bridge 4 1b = Open load detected on low-side switch of half-bridge 4
5	HB3_HS_OLD	R	0b	0b = No open load detected on high-side switch of half-bridge 3 1b = Open load detected on high-side switch of half-bridge 3
4	HB3_LS_OLD	R	0b	0b = No open load detected on low-side switch of half-bridge 3 1b = Open load detected on low-side switch of half-bridge 3
3	HB2_HS_OLD	R	0b	0b = No open load detected on high-side switch of half-bridge 2 1b = Open load detected on high-side switch of half-bridge 2
2	HB2_LS_OLD	R	0b	0b = No open load detected on low-side switch of half-bridge 2 1b = Open load detected on low-side switch of half-bridge 2
1	HB1_HS_OLD	R	0b	0b = No open load detected on high-side switch of half-bridge 1 1b = Open load detected on high-side switch of half-bridge 1
0	HB1_LS_OLD	R	0b	0b = No open load detected on low-side switch of half-bridge 1 1b = Open load detected on low-side switch of half-bridge 1

8.6.1.1.6 Open-Load Detect (OLD) Status 2 (OLD_STAT_2) Register (Address = 0x05) [reset = 0x00]

 The open-load detect (OLD) status 2 register is shown in [Figure 81](#) and described in [Table 25](#).

Register access type: Read only

Figure 81. Open-Load Detect (OLD) Status 2 Register

7	6	5	4	3	2	1	0
HB8_HS_OLD	HB8_LS_OLD	HB7_HS_OLD	HB7_LS_OLD	HB6_HS_OLD	HB6_LS_OLD	HB5_HS_OLD	HB5_LS_OLD
R-0b	R-0b	R-0b	R-0b	R-0b	R-0b	R-0b	R-0b

Table 25. Open-Load Detect (OLD) Status 2 Register Field Descriptions

Bit	Field	Type	Default	Description
7	HB8_HS_OLD	R	0b	0b = No open load detected on high-side switch of half-bridge 8 1b = Open load detected on high-side switch of half-bridge 8
6	HB8_LS_OLD	R	0b	0b = No open load detected on low-side switch of half-bridge 8 1b = Open load detected on low-side switch of half-bridge 8
5	HB7_HS_OLD	R	0b	0b = No open load detected on high-side switch of half-bridge 7 1b = Open load detected on high-side switch of half-bridge 7
4	HB7_LS_OLD	R	0b	0b = No open load detected on low-side switch of half-bridge 7 1b = Open load detected on low-side switch of half-bridge 7
3	HB6_HS_OLD	R	0b	0b = No open load detected on high-side switch of half-bridge 6 1b = Open load detected on high-side switch of half-bridge 6
2	HB6_LS_OLD	R	0b	0b = No open load detected on low-side switch of half-bridge 6 1b = Open load detected on low-side switch of half-bridge 6
1	HB5_HS_OLD	R	0b	0b = No open load detected on high-side switch of half-bridge 5 1b = Open load detected on high-side switch of half-bridge 5
0	HB5_LS_OLD	R	0b	0b = No open load detected on low-side switch of half-bridge 5 1b = Open load detected on low-side switch of half-bridge 5

8.6.1.1.7 Open-Load Detect (OLD) Status 3 (OLD_STAT_3) Register (Address = 0x06) [reset = 0x00]

The open-load detect (OLD) status 3 register is shown in [Figure 82](#) and described in [Table 26](#).

Register access type: Read only

Figure 82. Open-Load Detect (OLD) Status 3 Register

7	6	5	4	3	2	1	0
HB12_HS_OLD	HB12_LS_OLD	HB11_HS_OLD	HB11_LS_OLD	HB10_HS_OLD	HB10_LS_OLD	HB9_HS_OLD	HB9_LS_OLD
R-0b	R-0b	R-0b	R-0b	R-0b	R-0b	R-0b	R-0b

Table 26. Open-Load Detect (OLD) Status 3 Register Field Descriptions

Bit	Field	Type	Default	Description
7	HB12_HS_OLD	R	0b	0b = No open load detected on high-side switch of half-bridge 12 1b = Open load detected on high-side switch of half-bridge 12
6	HB12_LS_OLD	R	0b	0b = No open load detected on low-side switch of half-bridge 12 1b = Open load detected on low-side switch of half-bridge 12
5	HB11_HS_OLD	R	0b	0b = No open load detected on high-side switch of half-bridge 11 1b = Open load detected on high-side switch of half-bridge 11
4	HB11_LS_OLD	R	0b	0b = No open load detected on low-side switch of half-bridge 11 1b = Open load detected on low-side switch of half-bridge 11
3	HB10_HS_OLD	R	0b	0b = No open load detected on high-side switch of half-bridge 10 1b = Open load detected on high-side switch of half-bridge 10
2	HB10_LS_OLD	R	0b	0b = No open load detected on low-side switch of half-bridge 10 1b = Open load detected on low-side switch of half-bridge 10
1	HB9_HS_OLD	R	0b	0b = No open load detected on high-side switch of half-bridge 9 1b = Open load detected on high-side switch of half-bridge 9
0	HB9_LS_OLD	R	0b	0b = No open load detected on low-side switch of half-bridge 9 1b = Open load detected on low-side switch of half-bridge 9

8.6.1.2 Control Registers

The control registers are used to configure the device. The control registers are read and write capable.

[Table 27](#) lists the memory-mapped registers for the control registers. All register offset addresses not listed in [Table 27](#) should be considered as reserved locations and the register contents should not be modified.

Table 27. Control Registers Summary Table

Address	Register Name	Section
0x07	Configuration Register	Go
0x08	Operation Control 1 Register	Go
0x09	Operation Control 2 Register	Go
0x0A	Operation Control 3 Register	Go
0x0B	PWM Control 1 Register	Go
0x0C	PWM Control 2 Register	Go
0x0D	Free-Wheeling Control 1 Register	Go
0x0E	Free-Wheeling Control 2 Register	Go
0x0F	PWM Map Control 1 Register	Go
0x10	PWM Map Control 2 Register	Go
0x11	PWM Map Control 3 Register	Go
0x12	PWM Frequency Control Register	Go
0x13	PWM Duty Control Channel 1 Register	Go
0x14	PWM Duty Control Channel 2 Register	Go
0x15	PWM Duty Control Channel 3 Register	Go
0x16	PWM Duty Control Channel 4 Register	Go
0x17	Slew Rate Control 1 Register	Go
0x18	Slew Rate Control 2 Register	Go
0x19	Open-Load Detect Control 1 Register	Go
0x1A	Open-Load Detect Control 2 Register	Go
0x1B	Open-Load Detect Control 3 Register	Go
0x24	Open-Load Detect Control 4 Register	Go

8.6.1.2.1 Configuration (CONFIG_CTRL) Register (Address = 0x07) [reset = 0x00]

The configuration register is shown in Figure 83 and described in Table 28.

Register access type: Read/Write

Figure 83. Configuration Register

7	6	5	4	3	2	1	0
Reserved		IC_ID		OCP_REP	OTW_REP	EXT_OVP	CLR_FLT
R/W-0b	R-Xb	R-Xb	R-Xb	R/W-0b	R/W-0b	R/W-0b	R/W-0b

Table 28. Configuration Register Field Descriptions

Bit	Field	Type	Default	Description
7	Reserved	R/W	0b	Reserved
6-4	IC_ID	R	XXXb	000b = Device connected is DRV8912-Q1 (12 Channel Device) 001b = Device connected is DRV8910-Q1 (10 Channel Device) 010b = Device connected is DRV8908-Q1 (8 Channel Device) 011b = Device connected is DRV8906-Q1 (6 Channel Device) 100b = Device connected is DRV8904-Q1 (4 Channel Device) 101b = Reserved 110b = Reserved 111b = Reserved
3	OCP_REP	R/W	0b	0b = Overcurrent condition is reported in nFAULT pin 1b = Overcurrent condition warning is not reported on the nFAULT pin
2	OTW_REP	R/W	0b	0b = Overtemperature warning is not reported in nFAULT pin 1b = Overtemperature warning is reported on the nFAULT pin
1	EXT_OVP	R/W	0b	0b = Overvoltage protection threshold is at 21 V 1b = Overvoltage protection threshold is at 33 V
0	CLR_FLT	R/W	0b	0b = Faults not cleared 1b = Clear all faults

NOTE

CLR_FLT bit is an auto-clear bit and will always read '0'.

8.6.1.2.2 Operation Control 1 (OP_CTRL_1) Register (Address = 0x08) [reset = 0x00]

 The operation control 1 register is shown in [Figure 84](#) and described in [Table 29](#).

Register access type: Read/Write

Figure 84. Operation Control 1 Register

7	6	5	4	3	2	1	0
HB4_HS_EN	HB4_LS_EN	HB3_HS_EN	HB3_LS_EN	HB2_HS_EN	HB2_LS_EN	HB1_HS_EN	HB1_LS_EN
R/W-0b	R/W-0b	R/W-0b	R/W-0b	R/W-0b	R/W-0b	R/W-0b	R/W-0b

Table 29. Operation Control 1 Register Field Descriptions

Bit	Field	Type	Default	Description
7	HB4_HS_EN	R/W	0b	0b = Half-bridge 4 high-side switch is disabled 1b = Half-bridge 4 high-side switch is enabled
6	HB4_LS_EN	R/W	0b	0b = Half-bridge 4 low-side switch is disabled 1b = Half-bridge 4 low-side switch is enabled
5	HB3_HS_EN	R/W	0b	0b = Half-bridge 3 high-side switch is disabled 1b = Half-bridge 3 high-side switch is enabled
4	HB3_LS_EN	R/W	0b	0b = Half-bridge 3 low-side switch is disabled 1b = Half-bridge 3 low-side switch is enabled
3	HB2_HS_EN	R/W	0b	0b = Half-bridge 2 high-side switch is disabled 1b = Half-bridge 2 high-side switch is enabled
2	HB2_LS_EN	R/W	0b	0b = Half-bridge 2 low-side switch is disabled 1b = Half-bridge 2 low-side switch is enabled
1	HB1_HS_EN	R/W	0b	0b = Half-bridge 1 high-side switch is disabled 1b = Half-bridge 1 high-side switch is enabled
0	HB1_LS_EN	R/W	0b	0b = Half-bridge 1 low-side switch is disabled 1b = Half-bridge 1 low-side switch is enabled

8.6.1.2.3 Operation Control 2 (OP_CTRL_2) Register (Address = 0x09) [reset = 0x00]

The operation control 2 register is shown in [Figure 85](#) and described in [Table 30](#).

Register access type: Read/Write

Figure 85. Operation Control 2 Register

7	6	5	4	3	2	1	0
HB8_HS_EN	HB8_LS_EN	HB7_HS_EN	HB7_LS_EN	HB6_HS_EN	HB6_LS_EN	HB5_HS_EN	HB5_LS_EN
R/W-0b	R/W-0b	R/W-0b	R/W-0b	R/W-0b	R/W-0b	R/W-0b	R/W-0b

Table 30. Operation Control 2 Register Field Descriptions

Bit	Field	Type	Default	Description
7	HB8_HS_EN	R/W	0b	0b = Half-bridge 8 high-side switch is disabled 1b = Half-bridge 8 high-side switch is enabled
6	HB8_LS_EN	R/W	0b	0b = Half-bridge 8 low-side switch is disabled 1b = Half-bridge 8 low-side switch is enabled
5	HB7_HS_EN	R/W	0b	0b = Half-bridge 7 high-side switch is disabled 1b = Half-bridge 7 high-side switch is enabled
4	HB7_LS_EN	R/W	0b	0b = Half-bridge 7 low-side switch is disabled 1b = Half-bridge 7 low-side switch is enabled
3	HB6_HS_EN	R/W	0b	0b = Half-bridge 6 high-side switch is disabled 1b = Half-bridge 6 high-side switch is enabled
2	HB6_LS_EN	R/W	0b	0b = Half-bridge 6 low-side switch is disabled 1b = Half-bridge 6 low-side switch is enabled
1	HB5_HS_EN	R/W	0b	0b = Half-bridge 5 high-side switch is disabled 1b = Half-bridge 5 high-side switch is enabled
0	HB5_LS_EN	R/W	0b	0b = Half-bridge 5 low-side switch is disabled 1b = Half-bridge 5 low-side switch is enabled

8.6.1.2.4 Operation Control 3 (OP_CTRL_3) Register (Address = 0x0A) [reset = 0x00]

 The operation control 3 register is shown in [Figure 86](#) and described in [Table 31](#).

Register access type: Read/Write

Figure 86. Operation Control 3 Register

7	6	5	4	3	2	1	0
HB12_HS_EN	HB12_LS_EN	HB11_HS_EN	HB11_LS_EN	HB10_HS_EN	HB10_LS_EN	HB9_HS_EN	HB9_LS_EN
R/W-0b	R/W-0b	R/W-0b	R/W-0b	R/W-0b	R/W-0b	R/W-0b	R/W-0b

Table 31. Operation Control 3 Register Field Descriptions

Bit	Field	Type	Default	Description
7	HB12_HS_EN	R/W	0b	0b = Half-bridge 12 high-side switch is disabled 1b = Half-bridge 12 high-side switch is enabled
6	HB12_LS_EN	R/W	0b	0b = Half-bridge 12 low-side switch is disabled 1b = Half-bridge 12 low-side switch is enabled
5	HB11_HS_EN	R/W	0b	0b = Half-bridge 11 high-side switch is disabled 1b = Half-bridge 11 high-side switch is enabled
4	HB11_LS_EN	R/W	0b	0b = Half-bridge 11 low-side switch is disabled 1b = Half-bridge 11 low-side switch is enabled
3	HB10_HS_EN	R/W	0b	0b = Half-bridge 10 high-side switch is disabled 1b = Half-bridge 10 high-side switch is enabled
2	HB10_LS_EN	R/W	0b	0b = Half-bridge 10 low-side switch is disabled 1b = Half-bridge 10 low-side switch is enabled
1	HB9_HS_EN	R/W	0b	0b = Half-bridge 9 high-side switch is disabled 1b = Half-bridge 9 high-side switch is enabled
0	HB9_LS_EN	R/W	0b	0b = Half-bridge 9 low-side switch is disabled 1b = Half-bridge 9 low-side switch is enabled

8.6.1.2.5 PWM Control 1 (PWM_CTRL_1) Register (Address = 0x0B) [reset = 0x00]

The PWM control 1 register is shown in [Figure 87](#) and described in [Table 32](#).

Register access type: Read/Write

Figure 87. PWM Control 1 Register

7	6	5	4	3	2	1	0
HB8_PWM	HB7_PWM	HB6_PWM	HB5_PWM	HB4_PWM	HB3_PWM	HB2_PWM	HB1_PWM
R/W-0b	R/W-0b	R/W-0b	R/W-0b	R/W-0b	R/W-0b	R/W-0b	R/W-0b

Table 32. PWM Control 1 Register Field Descriptions

Bit	Field	Type	Default	Description
7	HB8_PWM	R/W	0b	0b = Half-bridge 8 is operating in continuous mode 1b = Half-bridge 8 is operating in PWM mode
6	HB7_PWM	R/W	0b	0b = Half-bridge 7 is operating in continuous mode 1b = Half-bridge 7 is operating in PWM mode
5	HB6_PWM	R/W	0b	0b = Half-bridge 6 is operating in continuous mode 1b = Half-bridge 6 is operating in PWM mode
4	HB5_PWM	R/W	0b	0b = Half-bridge 5 is operating in continuous mode 1b = Half-bridge 5 is operating in PWM mode
3	HB4_PWM	R/W	0b	0b = Half-bridge 4 is operating in continuous mode 1b = Half-bridge 4 is operating in PWM mode
2	HB3_PWM	R/W	0b	0b = Half-bridge 3 is operating in continuous mode 1b = Half-bridge 3 is operating in PWM mode
1	HB2_PWM	R/W	0b	0b = Half-bridge 2 is operating in continuous mode 1b = Half-bridge 2 is operating in PWM mode
0	HB1_PWM	R/W	0b	0b = Half-bridge 1 is operating in continuous mode 1b = Half-bridge 1 is operating in PWM mode

8.6.1.2.6 PWM Control 2 (PWM_CTRL_2) Register (Address = 0x0C) [reset = 0x00]

 The PWM control 2 register is shown in [Figure 88](#) and described in [Table 33](#).

Register access type: Read/Write

Figure 88. PWM Control 2 Register

7	6	5	4	3	2	1	0
PWM_CH4_DIS	PWM_CH3_DIS	PWM_CH2_DIS	PWM_CH1_DIS	HB12_PWM	HB11_PWM	HB10_PWM	HB9_PWM
R/W-0b	R/W-0b	R/W-0b	R/W-0b	R/W-0b	R/W-0b	R/W-0b	R/W-0b

Table 33. PWM Control 2 Register Field Descriptions

Bit	Field	Type	Default	Description
7	PWM_CH4_DIS	R/W	0b	0b = PWM Generator-4 is enabled 1b = PWM Generator-4 is disabled
6	PWM_CH3_DIS	R/W	0b	0b = PWM Generator-3 is enabled 1b = PWM Generator-3 is disabled
5	PWM_CH2_DIS	R/W	0b	0b = PWM Generator-2 is enabled 1b = PWM Generator-2 is disabled
4	PWM_CH1_DIS	R/W	0b	0b = PWM Generator-1 is enabled 1b = PWM Generator-1 is disabled
3	HB12_PWM	R/W	0b	0b = Half-bridge 12 is operating in continuous mode 1b = Half-bridge 12 is operating in PWM mode
2	HB11_PWM	R/W	0b	0b = Half-bridge 11 is operating in continuous mode 1b = Half-bridge 11 is operating in PWM mode
1	HB10_PWM	R/W	0b	0b = Half-bridge 10 is operating in continuous mode 1b = Half-bridge 10 is operating in PWM mode
0	HB9_PWM	R/W	0b	0b = Half-bridge 9 is operating in continuous mode 1b = Half-bridge 9 is operating in PWM mode

8.6.1.2.7 Free-Wheeling Control 1 (FW_CTRL_1) Register (Address = 0x0D) [reset = 0x00]

The free-wheeling control 1 register is shown in [Figure 89](#) and described in [Table 34](#).

Register access type: Read/Write

Figure 89. Free-Wheeling Control 1 Register

7	6	5	4	3	2	1	0
HB8_FW	HB7_FW	HB6_FW	HB5_FW	HB4_FW	HB3_FW	HB2_FW	HB1_FW
R/W-0b	R/W-0b	R/W-0b	R/W-0b	R/W-0b	R/W-0b	R/W-0b	R/W-0b

Table 34. Free-Wheeling Control 1 Register Field Descriptions

Bit	Field	Type	Default	Description
7	HB8_FW	R/W	0b	0b = Passive free-wheeling on half-bridge 8 is enabled 1b = Active free-wheeling on half-bridge 8 is enabled
6	HB7_FW	R/W	0b	0b = Passive free-wheeling on half-bridge 7 is enabled 1b = Active free-wheeling on half-bridge 7 is enabled
5	HB6_FW	R/W	0b	0b = Passive free-wheeling on half-bridge 6 is enabled 1b = Active free-wheeling on half-bridge 6 is enabled
4	HB5_FW	R/W	0b	0b = Passive free-wheeling on half-bridge 5 is enabled 1b = Active free-wheeling on half-bridge 5 is enabled
3	HB4_FW	R/W	0b	0b = Passive free-wheeling on half-bridge 4 is enabled 1b = Active free-wheeling on half-bridge 4 is enabled
2	HB3_FW	R/W	0b	0b = Passive free-wheeling on half-bridge 3 is enabled 1b = Active free-wheeling on half-bridge 3 is enabled
1	HB2_FW	R/W	0b	0b = Passive free-wheeling on half-bridge 2 is enabled 1b = Active free-wheeling on half-bridge 2 is enabled
0	HB1_FW	R/W	0b	0b = Passive free-wheeling on half-bridge 1 is enabled 1b = Active free-wheeling on half-bridge 1 is enabled

8.6.1.2.8 Free-Wheeling Control 2 (FW_CTRL_2) Register (Address = 0x0E) [reset = 0x00]

The free-wheeling control 2 register is shown in [Figure 90](#) and described in [Table 35](#).

Register access type: Read/Write

Figure 90. Free-Wheeling Control 2 Register

7	6	5	4	3	2	1	0
Reserved				HB12_FW	HB11_FW	HB10_FW	HB9_FW
R/W-0b	R/W-0b	R/W-0b	R/W-0b	R/W-0b	R/W-0b	R/W-0b	R/W-0b

Table 35. Free-Wheeling Control 2 Register Field Descriptions

Bit	Field	Type	Default	Description
7-4	Reserved	R/W	0000b	Reserved
3	HB12_FW	R/W	0b	0b = Passive free-wheeling on half-bridge 12 is enabled 1b = Active free-wheeling on half-bridge 12 is enabled
2	HB11_FW	R/W	0b	0b = Passive free-wheeling on half-bridge 11 is enabled 1b = Active free-wheeling on half-bridge 11 is enabled
1	HB10_FW	R/W	0b	0b = Passive free-wheeling on half-bridge 10 is enabled 1b = Active free-wheeling on half-bridge 10 is enabled
0	HB9_FW	R/W	0b	0b = Passive free-wheeling on half-bridge 9 is enabled 1b = Active free-wheeling on half-bridge 9 is enabled

8.6.1.2.9 PWM Map Control 1 (PWM_MAP_CTRL_1) Register (Address = 0x0F) [reset = 0x00]

The PWM Map Control 1 register is shown in [Figure 91](#) and described in [Table 36](#).

Register access type: Read/Write

Figure 91. PWM Map Control 1 Register

7	6	5	4	3	2	1	0
HB4_PWM_MAP		HB3_PWM_MAP		HB2_PWM_MAP		HB1_PWM_MAP	
R/W-0b	R/W-0b	R/W-0b	R/W-0b	R/W-0b	R/W-0b	R/W-0b	R/W-0b

Table 36. PWM Map Control 1 Register Field Descriptions

Bit	Field	Type	Default	Description
7-6	HB4_PWM_MAP	R/W	00b	00b = HB4 mapped to PWM channel 1 01b = HB4 mapped to PWM channel 2 10b = HB4 mapped to PWM channel 3 11b = HB4 mapped to PWM channel 4
5-4	HB3_PWM_MAP	R/W	00b	00b = HB3 mapped to PWM channel 1 01b = HB3 mapped to PWM channel 2 10b = HB3 mapped to PWM channel 3 11b = HB3 mapped to PWM channel 4
3-2	HB2_PWM_MAP	R/W	00b	00b = HB2 mapped to PWM channel 1 01b = HB2 mapped to PWM channel 2 10b = HB2 mapped to PWM channel 3 11b = HB2 mapped to PWM channel 4
1-0	HB1_PWM_MAP	R/W	00b	00b = HB1 mapped to PWM channel 1 01b = HB1 mapped to PWM channel 2 10b = HB1 mapped to PWM channel 3 11b = HB1 mapped to PWM channel 4

8.6.1.2.10 PWM Map Control 2 (PWM_MAP_CTRL_2) Register (Address = 0x10) [reset = 0x00]

The PWM Map Control 2 register is shown in [Figure 92](#) and described in [Table 37](#).

Register access type: Read/Write

Figure 92. PWM Map Control 2 Register

7	6	5	4	3	2	1	0
HB8_PWM_MAP		HB7_PWM_MAP		HB6_PWM_MAP		HB5_PWM_MAP	
R/W-0b	R/W-0b	R/W-0b	R/W-0b	R/W-0b	R/W-0b	R/W-0b	R/W-0b

Table 37. PWM Map Control 2 Register Field Descriptions

Bit	Field	Type	Default	Description
7-6	HB8_PWM_MAP	R/W	00b	00b = HB8 mapped to PWM channel 1 01b = HB8 mapped to PWM channel 2 10b = HB8 mapped to PWM channel 3 11b = HB8 mapped to PWM channel 4
5-4	HB7_PWM_MAP	R/W	00b	00b = HB7 mapped to PWM channel 1 01b = HB7 mapped to PWM channel 2 10b = HB7 mapped to PWM channel 3 11b = HB7 mapped to PWM channel 4
3-2	HB6_PWM_MAP	R/W	00b	00b = HB6 mapped to PWM channel 1 01b = HB6 mapped to PWM channel 2 10b = HB6 mapped to PWM channel 3 11b = HB6 mapped to PWM channel 4
1-0	HB5_PWM_MAP	R/W	00b	00b = HB5 mapped to PWM channel 1 01b = HB5 mapped to PWM channel 2 10b = HB5 mapped to PWM channel 3 11b = HB5 mapped to PWM channel 4

8.6.1.2.11 PWM Map Control 3 (PWM_MAP_CTRL_3) Register (Address = 0x11) [reset = 0x00]

The PWM Map Control 3 register is shown in [Figure 93](#) and described in [Table 38](#).

Register access type: Read/Write

Figure 93. PWM Map Control 3 Register

7	6	5	4	3	2	1	0
HB12_PWM_MAP		HB11_PWM_MAP		HB10_PWM_MAP		HB9_PWM_MAP	
R/W-0b	R/W-0b	R/W-0b	R/W-0b	R/W-0b	R/W-0b	R/W-0b	R/W-0b

Table 38. PWM Map Control 3 Register Field Descriptions

Bit	Field	Type	Default	Description
7-6	HB12_PWM_MAP	R/W	00b	00b = HB12 mapped to PWM channel 1 01b = HB12 mapped to PWM channel 2 10b = HB12 mapped to PWM channel 3 11b = HB12 mapped to PWM channel 4
5-4	HB11_PWM_MAP	R/W	00b	00b = HB11 mapped to PWM channel 1 01b = HB11 mapped to PWM channel 2 10b = HB11 mapped to PWM channel 3 11b = HB11 mapped to PWM channel 4
3-2	HB10_PWM_MAP	R/W	00b	00b = HB10 mapped to PWM channel 1 01b = HB10 mapped to PWM channel 2 10b = HB10 mapped to PWM channel 3 11b = HB10 mapped to PWM channel 4
1-0	HB9_PWM_MAP	R/W	00b	00b = HB9 mapped to PWM channel 1 01b = HB9 mapped to PWM channel 2 10b = HB9 mapped to PWM channel 3 11b = HB9 mapped to PWM channel 4

8.6.1.2.12 PWM Frequency Control (PWM_FREQ_CTRL) Register (Address = 0x12) [reset = 0x00]

 The PWM Frequency Control register is shown in [Figure 94](#) and described in [Table 39](#).

Register access type: Read/Write

Figure 94. PWM Frequency Control Register

7	6	5	4	3	2	1	0
PWM_CH4_FREQ		PWM_CH3_FREQ		PWM_CH2_FREQ		PWM_CH1_FREQ	
R/W-0b	R/W-0b	R/W-0b	R/W-0b	R/W-0b	R/W-0b	R/W-0b	R/W-0b

Table 39. PWM Frequency Control Register Field Descriptions

Bit	Field	Type	Default	Description
7-6	PWM_CH4_FREQ	R/W	00b	00b = PWM frequency is 80 Hz 01b = PWM frequency is 100 Hz 10b = PWM frequency is 200 Hz 11b = PWM frequency is 2000 Hz
5-4	PWM_CH3_FREQ	R/W	00b	00b = PWM frequency is 80 Hz 01b = PWM frequency is 100 Hz 10b = PWM frequency is 200 Hz 11b = PWM frequency is 2000 Hz
3-2	PWM_CH2_FREQ	R/W	00b	00b = PWM frequency is 80 Hz 01b = PWM frequency is 100 Hz 10b = PWM frequency is 200 Hz 11b = PWM frequency is 2000 Hz
1-0	PWM_CH1_FREQ	R/W	00b	00b = PWM frequency is 80 Hz 01b = PWM frequency is 100 Hz 10b = PWM frequency is 200 Hz 11b = PWM frequency is 2000 Hz

8.6.1.2.13 PWM Duty Control Channel 1 (PWM_DUTY_CH1) Register (Address = 0x13) [reset = 0x00]

The channel 1 PWM duty cycle control register is shown in [Figure 95](#) and described in [Table 40](#).

Register access type: Read/Write

Figure 95. PWM Duty Control Channel 1 Register

7	6	5	4	3	2	1	0
PWM_DUTY_CH1							
R/W-0b	R/W-0b	R/W-0b	R/W-0b	R/W-0b	R/W-0b	R/W-0b	R/W-0b

Table 40. PWM Duty Control Channel 1 Register Field Descriptions

Bit	Field	Type	Default	Description
7-0	PWM_DUTY_CH1	R/W	00000000b	00000000b = 0 % PWM Duty 11111111b = 100 % PWM Duty Calculate duty as decimal (xxxxxxx) × 1/255

8.6.1.2.14 PWM Duty Control Channel 2 (PWM_DUTY_CH2) Register (Address = 0x14) [reset = 0x00]

The channel 2 PWM duty cycle control register is shown in [Figure 96](#) and described in [Table 41](#).

Register access type: Read/Write

Figure 96. PWM Duty Control Channel 2 Register

7	6	5	4	3	2	1	0
PWM_DUTY_CH2							
R/W-0b	R/W-0b	R/W-0b	R/W-0b	R/W-0b	R/W-0b	R/W-0b	R/W-0b

Table 41. PWM Duty Control Channel 2 Register Field Descriptions

Bit	Field	Type	Default	Description
7-0	PWM_DUTY_CH2	R/W	00000000b	00000000b = 0 % PWM Duty 11111111b = 100 % PWM Duty Calculate duty as decimal (xxxxxxx) × 1/255

8.6.1.2.15 PWM Duty Control Channel 3 (PWM_DUTY_CH3) Register (Address = 0x15) [reset = 0x00]

The channel 3 PWM duty cycle control register is shown in [Figure 97](#) and described in [Table 42](#).

Register access type: Read/Write

Figure 97. PWM Duty Control Channel 3 Register

7	6	5	4	3	2	1	0
PWM_DUTY_CH3							
R/W-0b	R/W-0b	R/W-0b	R/W-0b	R/W-0b	R/W-0b	R/W-0b	R/W-0b

Table 42. PWM Duty Control Channel 3 Register Field Descriptions

Bit	Field	Type	Default	Description
7-0	PWM_DUTY_CH3	R/W	00000000b	00000000b = 0 % PWM Duty 11111111b = 100 % PWM Duty Calculate duty as decimal (xxxxxxx) × 1/255

8.6.1.2.16 PWM Duty Control Channel 4 (PWM_DUTY_CH4) Register (Address = 0x16) [reset = 0x00]

The channel 4 PWM duty cycle control register is shown in [Figure 98](#) and described in [Table 43](#).

Register access type: Read/Write

Figure 98. PWM Duty Control Channel 4 Register

7	6	5	4	3	2	1	0
PWM_DUTY_CH4							
R/W-0b	R/W-0b	R/W-0b	R/W-0b	R/W-0b	R/W-0b	R/W-0b	R/W-0b

Table 43. PWM Duty Control Channel 4 Register Field Descriptions

Bit	Field	Type	Default	Description
7-0	PWM_DUTY_CH4	R/W	00000000b	00000000b = 0 % PWM Duty 11111111b = 100 % PWM Duty Calculate duty as decimal (xxxxxxx) × 1/255

8.6.1.2.17 Slew Rate Control 1 (SR_CTRL_1) Register (Address = 0x17) [reset = 0x00]

The slew rate control 1 register is shown in Figure 99 and described in Table 44.

Register access type: Read/Write

Figure 99. Slew Rate Control 1 Register

7	6	5	4	3	2	1	0
HB8_SR	HB7_SR	HB6_SR	HB5_SR	HB4_SR	HB3_SR	HB2_SR	HB1_SR
R/W-0b	R/W-0b	R/W-0b	R/W-0b	R/W-0b	R/W-0b	R/W-0b	R/W-0b

Table 44. Slew Rate Control 1 Register Field Descriptions

Bit	Field	Type	Default	Description
7	HB8_SR	R/W	0b	0b = 0.6 V/μs 1b = 2.5 V/μs
6	HB7_SR	R/W	0b	0b = 0.6 V/μs 1b = 2.5 V/μs
5	HB6_SR	R/W	0b	0b = 0.6 V/μs 1b = 2.5 V/μs
4	HB5_SR	R/W	0b	0b = 0.6 V/μs 1b = 2.5 V/μs
3	HB4_SR	R/W	0b	0b = 0.6 V/μs 1b = 2.5 V/μs
2	HB3_SR	R/W	0b	0b = 0.6 V/μs 1b = 2.5 V/μs
1	HB2_SR	R/W	0b	0b = 0.6 V/μs 1b = 2.5 V/μs
0	HB1_SR	R/W	0b	0b = 0.6 V/μs 1b = 2.5 V/μs

8.6.1.2.18 Slew Rate Control 2 (SR_CTRL_2) Register (Address = 0x18) [reset = 0x00]

 The slew rate control 2 register is shown in [Figure 100](#) and described in [Table 45](#).

Register access type: Read/Write

Figure 100. Slew Rate Control 2 Register

7	6	5	4	3	2	1	0
Reserved				HB12_SR	HB11_SR	HB10_SR	HB9_SR
R/W-0b	R/W-0b	R/W-0b	R/W-0b	R/W-0b	R/W-0b	R/W-0b	R/W-0b

Table 45. Slew Rate Control 2 Register Field Descriptions

Bit	Field	Type	Default	Description
7-4	Reserved	R/W	0000b	Reserved
3	HB12_SR	R/W	0b	0b = 0.6 V/μs 1b = 2.5 V/μs
2	HB11_SR	R/W	0b	0b = 0.6 V/μs 1b = 2.5 V/μs
1	HB10_SR	R/W	0b	0b = 0.6 V/μs 1b = 2.5 V/μs
0	HB9_SR	R/W	0b	0b = 0.6 V/μs 1b = 2.5 V/μs

8.6.1.2.19 Open-Load Detect (OLD) Control 1 (OLD_CTRL_1) Register (Address = 0x19) [reset = 0x00]

The open-load detect (OLD) control (OLD_CTRL_1) register-1 is shown in [Figure 101](#) and described in [Table 46](#).

Register access type: Read/Write

Figure 101. Open-Load Detect (OLD) Control (OLD_CTRL_1) Register

7	6	5	4	3	2	1	0
HB8_OLD_DIS	HB7_OLD_DIS	HB6_OLD_DIS	HB5_OLD_DIS	HB4_OLD_DIS	HB3_OLD_DIS	HB2_OLD_DIS	HB1_OLD_DIS
R/W-0b	R/W-0b	R/W-0b	R/W-0b	R/W-0b	R/W-0b	R/W-0b	R/W-0b

Table 46. Open-Load Detect (OLD) Control (OLD_CTRL_1) Register Field Descriptions

Bit	Field	Type	Default	Description
7	HB8_OLD_DIS	R/W	0b	0b = Open-load detection on half-bridge 8 is enabled 1b = Open-load on half-bridge 8 is disabled
6	HB7_OLD_DIS	R/W	0b	0b = Open-load detection on half-bridge 7 is enabled 1b = Open-load on half-bridge 7 is disabled
5	HB6_OLD_DIS	R/W	0b	0b = Open-load detection on half-bridge 6 is enabled 1b = Open-load on half-bridge 6 is disabled
4	HB5_OLD_DIS	R/W	0b	0b = Open-load detection on half-bridge 5 is enabled 1b = Open-load on half-bridge 5 is disabled
3	HB4_OLD_DIS	R/W	0b	0b = Open-load detection on half-bridge 4 is enabled 1b = Open-load on half-bridge 4 is disabled
2	HB3_OLD_DIS	R/W	0b	0b = Open-load detection on half-bridge 3 is enabled 1b = Open-load on half-bridge 3 is disabled
1	HB2_OLD_DIS	R/W	0b	0b = Open-load detection on half-bridge 2 is enabled 1b = Open-load on half-bridge 2 is disabled
0	HB1_OLD_DIS	R/W	0b	0b = Open-load detection on half-bridge 1 is enabled 1b = Open-load on half-bridge 1 is disabled

8.6.1.2.20 Open-Load Detect (OLD) Control 2 (OLD_CTRL_2) Register (Address = 0x1A) [reset = 0x00]

 The open-load detect (OLD) control (OLD_CTRL_2) register-2 is shown in [Figure 102](#) and described in [Table 47](#).

Register access type: Read/Write

Figure 102. Open-Load Detect (OLD) Control (OLD_CTRL_2) Register

7	6	5	4	3	2	1	0
OLD_REP	OLD_OP	PL_MODE_EN	HB12_OLD_DIS	HB11_OLD_DIS	HB10_OLD_DIS	HB9_OLD_DIS	
R/W-0b	R/W-0b	R/W-0b	R/W-0b	R/W-0b	R/W-0b	R/W-0b	R/W-0b

Table 47. Open-Load Detect (OLD) Control (OLD_CTRL_2) Register Field Descriptions

Bit	Field	Type	Default	Description
7	OLD_REP	R/W	0b	0b = Report on nFAULT pin during OLD condition 1b = No report on nFAULT pin during OLD condition
6	OLD_OP	R/W	0b	0b = Half bridges are not active after OLD condition detect 1b = Half bridges are active after OLD condition detect
5-4	PL_MODE_EN	W	00b	00b = Parallel mode OCP fast turn-off slew is enabled 01b = Parallel mode OCP slow turn-off slew is enabled 10b = Invalid Setting 11b = Invalid Setting
3	HB12_OLD_DIS	R/W	0b	0b = Open-load detection on half-bridge 12 is enabled 1b = Open-load on half-bridge 12 is disabled
2	HB11_OLD_DIS	R/W	0b	0b = Open-load detection on half-bridge 11 is enabled 1b = Open-load on half-bridge 11 is disabled
1	HB10_OLD_DIS	R/W	0b	0b = Open-load detection on half-bridge 10 is enabled 1b = Open-load on half-bridge 10 is disabled
0	HB9_OLD_DIS	R/W	0b	0b = Open-load detection on half-bridge 9 is enabled 1b = Open-load on half-bridge 9 is disabled

NOTE

For DRV8912 and DRV8910, the PL_MODE_EN is write only bits and always read 00b.

8.6.1.2.21 Open-Load Detect (OLD) Control 3 (OLD_CTRL_3) Register (Address = 0x1B) [reset = 0x00]

The open-load detect (OLD) control (OLD_CTRL_3) register-3 is shown in [Figure 103](#) and described in [Table 48](#). This register also contains the bits to set the OCP deglitch time (OCP_DEG).

Register access type: Read/Write

Figure 103. Open-Load Detect (OLD) Control (OLD_CTRL_3) Register

7	6	5	4	3	2	1	0
OCP_DEG		OLD_NEG_EN		HB12_LOLD_EN	HB11_LOLD_EN	HB10_LOLD_EN	HB9_LOLD_EN
R/W-0b		R/W-0b		R/W-0b	R/W-0b	R/W-0b	R/W-0b

Table 48. Open-Load Detect (OLD) Control (OLD_CTRL_3) Register Field Descriptions

Bit	Field	Type	Default	Description
7-5	OCP_DEG	R/W	000b	000b = OCP deglitch time is 10 μs 001b = OCP deglitch time is 5 μs 010b = OCP deglitch time is 2.5μs 011b = OCP deglitch time is 1 μs 100b = OCP deglitch time is 60 μs 101b = OCP deglitch time is 40 μs 110b = OCP deglitch time is 30 μs 111b = OCP deglitch time is 20 μs
4	OLD_NEG_EN	R/W	0b	0b = Negative-current OLD mode is disabled 1b = Negative-current OLD mode is enabled
3	HB12_LOLD_EN	R/W	0b	0b = Low-current OLD on half-bridge 12 is disabled 1b = Low-current OLD on half-bridge 12 is enabled
2	HB11_LOLD_EN	R/W	0b	0b = Low-current OLD on half-bridge 11 is disabled 1b = Low-current OLD on half-bridge 12 is enabled
1	HB10_LOLD_EN	R/W	0b	0b = Low-current OLD on half-bridge 10 is disabled 1b = Low-current OLD on half-bridge 12 is enabled
0	HB9_LOLD_EN	R/W	0b	0b = Low-current OLD on half-bridge 9 is disabled 1b = Low-current OLD on half-bridge 9 is enabled

8.6.1.2.22 Open-Load Detect (OLD) Control 4 (OLD_CTRL_4) Register (Address = 0x24) [reset = 0x00]

 The open-load detect (OLD) control (OLD_CTRL_4) register-4 is shown in [Figure 104](#) and described in [Table 49](#).

Register access type: Read/Write

Figure 104. Open-Load Detect (OLD) Control (OLD_CTRL_4) Register

7	6	5	4	3	2	1	0
HB8_LCOLD_EN	HB7_LOLD_EN	HB6_LOLD_EN	HB5_LOLD_EN	HB4_LOLD_EN	HB3_LOLD_EN	HB2_LOLD_EN	HB1_LOLD_EN
R/W-0b	R/W-0b	R/W-0b	R/W-0b	R/W-0b	R/W-0b	R/W-0b	R/W-0b

Table 49. Open-Load Detect (OLD) Control (OLD_CTRL_4) Register Field Descriptions

Bit	Field	Type	Default	Description
7	HB8_LOLD_EN	R/W	0b	0b = Low-current OLD on half-bridge 8 is disabled 1b = Low-current OLD on half-bridge 8 is enabled
6	HB7_LOLD_EN	R/W	0b	0b = Low-current OLD on half-bridge 7 is disabled 1b = Low-current OLD on half-bridge 7 is enabled
5	HB6_LOLD_EN	R/W	0b	0b = Low-current OLD on half-bridge 6 is disabled 1b = Low-current OLD on half-bridge 6 is enabled
4	HB5_LOLD_EN	R/W	0b	0b = Low-current OLD on half-bridge 5 is disabled 1b = Low-current OLD on half-bridge 5 is enabled
3	HB4_LOLD_EN	R/W	0b	0b = Low-current OLD on half-bridge 4 is disabled 1b = Low-current OLD on half-bridge 4 is enabled
2	HB3_LOLD_EN	R/W	0b	0b = Low-current OLD on half-bridge 3 is disabled 1b = Low-current OLD on half-bridge 3 is enabled
1	HB2_LOLD_EN	R/W	0b	0b = Low-current OLD on half-bridge 2 is disabled 1b = Low-current OLD on half-bridge 2 is enabled
0	HB1_LOLD_EN	R/W	0b	0b = Low-current OLD on half-bridge 1 is disabled 1b = Low-current OLD on half-bridge 1 is enabled

8.6.2 DRV8908-Q1, DRV8906-Q1 and DRV8904-Q1 Register Maps

Table 50. DRV8908-Q1 Register Map

Name	7	6	5	4	3	2	1	0	Type	Address
IC_STAT	Reserved	OTSD	OTW	OLD	OCP	UVLO	OVP	NPOR	R	00h
OCP_STAT_1	HB4_HS_OCP	HB4_LS_OCP	HB3_HS_OCP	HB3_LS_OCP	HB2_HS_OCP	HB2_LS_OCP	HB1_HS_OCP	HB1_LS_OCP	R	01h
OCP_STAT_2	HB8_HS_OCP	HB8_LS_OCP	HB7_HS_OCP	HB7_LS_OCP	HB6_HS_OCP	HB6_LS_OCP	HB5_HS_OCP	HB5_LS_OCP	R	02h
OCP_STAT_3	Reserved								R	03h
OLD_STAT_1	HB4_HS_OLD	HB4_LS_OLD	HB3_HS_OLD	HB3_LS_OLD	HB2_HS_OLD	HB2_LS_OLD	HB1_HS_OLD	HB1_LS_OLD	R	04h
OLD_STAT_2	HB8_HS_OLD	HB8_LS_OLD	HB7_HS_OLD	HB7_LS_OLD	HB6_HS_OLD	HB6_LS_OLD	HB5_HS_OLD	HB5_LS_OLD	R	05h
OLD_STAT_3	Reserved								R	06h
CONFIG_CTRL	POLD_EN	IC_ID			OCP_REP	OTW_REP	EXT_OVP	CLR_FLT	RW	07h
OP_CTRL_1	HB4_HS_EN	HB4_LS_EN	HB3_HS_EN	HB3_LS_EN	HB2_HS_EN	HB2_LS_EN	HB1_HS_EN	HB1_LS_EN	RW	08h
OP_CTRL_2	HB8_HS_EN	HB8_LS_EN	HB7_HS_EN	HB7_LS_EN	HB6_HS_EN	HB6_LS_EN	HB5_HS_EN	HB5_LS_EN	RW	09h
OP_CTRL_3	Reserved								RW	0Ah
PWM_CTRL_1	HB8_PWM	HB7_PWM	HB6_PWM	HB5_PWM	HB4_PWM	HB3_PWM	HB2_PWM	HB1_PWM	RW	0Bh
PWM_CTRL_2	PWM_CH8_DIS	PWM_CH7_DIS	PWM_CH6_DIS	PWM_CH5_DIS	PWM_CH4_DIS	PWM_CH3_DIS	PWM_CH2_DIS	PWM_CH1_DIS	RW	0Ch
FW_CTRL_1	HB8_FW	HB7_FW	HB6_FW	HB5_FW	HB4_FW	HB3_FW	HB2_FW	HB1_FW	RW	0Dh
FW_CTRL_2	Reserved								RW	0Eh
PWM_MAP_CTRL_1	Reserved		HB2_PWM_MAP			HB1_PWM_MAP			RW	0Fh
PWM_MAP_CTRL_2 ⁽¹⁾	Reserved		HB4_PWM_MAP			HB3_PWM_MAP			RW	10h ⁽¹⁾
PWM_MAP_CTRL_3	Reserved		HB6_PWM_MAP			HB5_PWM_MAP			RW	11h
PWM_MAP_CTRL_4	Reserved		HB8_PWM_MAP			HB7_PWM_MAP			RW	12h
PWM_FREQ_CTRL_1	PWM_CH4_FREQ		PWM_CH3_FREQ		PWM_CH2_FREQ		PWM_CH1_FREQ		RW	13h
PWM_FREQ_CTRL_2	PWM_CH8_FREQ		PWM_CH7_FREQ		PWM_CH6_FREQ		PWM_CH5_FREQ		RW	14h
PWM_DUTY_CTRL_1	PWM_DUTY_CH1								RW	15h
PWM_DUTY_CTRL_2	PWM_DUTY_CH2								RW	16h
PWM_DUTY_CTRL_3	PWM_DUTY_CH3								RW	17h
PWM_DUTY_CTRL_4	PWM_DUTY_CH4								RW	18h
PWM_DUTY_CTRL_5	PWM_DUTY_CH5								RW	19h
PWM_DUTY_CTRL_6	PWM_DUTY_CH6								RW	1Ah
PWM_DUTY_CTRL_7	PWM_DUTY_CH7								RW	1Bh
PWM_DUTY_CTRL_8	PWM_DUTY_CH8								RW	1Ch
SR_CTRL_1	HB8_SR	HB7_SR	HB6_SR	HB5_SR	HB4_SR	HB3_SR	HB2_SR	HB1_SR	RW	1Dh

(1) After this register address, the register functions are similar among DRV8908-Q1, DRV8906-Q1, and DRV8904-Q1. However, DRV8912-Q1 and DRV8910-Q1 have different functions for these addresses.

Table 50. DRV8908-Q1 Register Map (continued)

Name	7	6	5	4	3	2	1	0	Type	Address
SR_CTRL_2	Reserved								RW	1Eh
OLD_CTRL_1	HB8_OLD_DIS	HB7_OLD_DIS	HB6_OLD_DIS	HB5_OLD_DIS	HB4_OLD_DIS	HB3_OLD_DIS	HB2_OLD_DIS	HB1_OLD_DIS	RW	1Fh
OLD_CTRL_2	OLD_REP	OLD_OP	PL_MODE_EN		Reserved				RW	20h
OLD_CTRL_3	OCP_DEG			OLD_NEG_EN	Reserved				RW	21h
OLD_CTRL_4	HB8_LOLD_EN	HB7_LOLD_EN	HB6_LOLD_EN	HB5_LOLD_EN	HB4_LOLD_EN	HB3_LOLD_EN	HB2_LOLD_EN	HB1_LOLD_EN	RW	22h
OLD_CTRL_5	HB8_POLD_EN	HB7_POLD_EN	HB6_POLD_EN	HB5_POLD_EN	HB4_POLD_EN	HB3_POLD_EN	HB2_POLD_EN	HB1_POLD_EN	RW	23h
OLD_CTRL_6	HB8_VM_POLD	HB7_VM_POLD	HB6_VM_POLD	HB5_VM_POLD	HB4_VM_POLD	HB3_VM_POLD	HB2_VM_POLD	HB1_VM_POLD	RW	24h

Table 51. DRV8906-Q1 Register Map

Name	7	6	5	4	3	2	1	0	Type	Address
IC_STAT	Reserved	OTSD	OTW	OLD	OCP	UVLO	OVP	NPOR	R	00h
OCP_STAT_1	HB4_HS_OCP	HB4_LS_OCP	HB3_HS_OCP	HB3_LS_OCP	HB2_HS_OCP	HB2_LS_OCP	HB1_HS_OCP	HB1_LS_OCP	R	01h
OCP_STAT_2	Reserved				HB6_HS_OCP	HB6_LS_OCP	HB5_HS_OCP	HB5_LS_OCP	R	02h
OCP_STAT_3	Reserved								R	03h
OLD_STAT_1	HB4_HS_OLD	HB4_LS_OLD	HB3_HS_OLD	HB3_LS_OLD	HB2_HS_OLD	HB2_LS_OLD	HB1_HS_OLD	HB1_LS_OLD	R	04h
OLD_STAT_2	Reserved				HB6_HS_OLD	HB6_LS_OLD	HB5_HS_OLD	HB5_LS_OLD	R	05h
OLD_STAT_3	Reserved								R	06h
CONFIG_CTRL	POLD_EN	IC_ID			OCP_REP	OTW_REP	EXT_OVP	CLR_FLT	RW	07h
OP_CTRL_1	HB4_HS_EN	HB4_LS_EN	HB3_HS_EN	HB3_LS_EN	HB2_HS_EN	HB2_LS_EN	HB1_HS_EN	HB1_LS_EN	RW	08h
OP_CTRL_2	Reserved				HB6_HS_EN	HB6_LS_EN	HB5_HS_EN	HB5_LS_EN	RW	09h
OP_CTRL_3	Reserved								RW	0Ah
PWM_CTRL_1	Reserved		HB6_PWM	HB5_PWM	HB4_PWM	HB3_PWM	HB2_PWM	HB1_PWM	RW	0Bh
PWM_CTRL_2	Reserved		PWM_CH6_DIS	PWM_CH5_DIS	PWM_CH4_DIS	PWM_CH3_DIS	PWM_CH2_DIS	PWM_CH1_DIS	RW	0Ch
FW_CTRL_1	Reserved		HB6_FW	HB5_FW	HB4_FW	HB3_FW	HB2_FW	HB1_FW	RW	0Dh
FW_CTRL_2	Reserved								RW	0Eh
PWM_MAP_CTRL_1	Reserved		HB2_PWM_MAP			HB1_PWM_MAP			RW	0Fh
PWM_MAP_CTRL_2 ⁽¹⁾	Reserved		HB4_PWM_MAP			HB3_PWM_MAP			RW	10h ⁽¹⁾
PWM_MAP_CTRL_3	Reserved		HB6_PWM_MAP			HB5_PWM_MAP			RW	11h
PWM_MAP_CTRL_4	Reserved								RW	12h
PWM_FREQ_CTRL_1	PWM_CH4_FREQ		PWM_CH3_FREQ		PWM_CH2_FREQ		PWM_CH1_FREQ		RW	13h
PWM_FREQ_CTRL_2	Reserved				PWM_CH6_FREQ		PWM_CH5_FREQ		RW	14h
PWM_DUTY_CTRL_1	PWM_DUTY_CH1								RW	15h
PWM_DUTY_CTRL_2	PWM_DUTY_CH2								RW	16h
PWM_DUTY_CTRL_3	PWM_DUTY_CH3								RW	17h
PWM_DUTY_CTRL_4	PWM_DUTY_CH4								RW	18h
PWM_DUTY_CTRL_5	PWM_DUTY_CH5								RW	19h
PWM_DUTY_CTRL_6	PWM_DUTY_CH6								RW	1Ah
PWM_DUTY_CTRL_7	Reserved								RW	1Bh
PWM_DUTY_CTRL_8	Reserved								RW	1Ch
SR_CTRL_1	Reserved		HB6_SR	HB5_SR	HB4_SR	HB3_SR	HB2_SR	HB1_SR	RW	1Dh
SR_CTRL_2	Reserved								RW	1Eh
OLD_CTRL_1	Reserved		HB6_OLD_DIS	HB5_OLD_DIS	HB4_OLD_DIS	HB3_OLD_DIS	HB2_OLD_DIS	HB1_OLD_DIS	RW	1Fh

(1) After this register address, the register functions are similar among DRV8908-Q1, DRV8906-Q1, and DRV8904-Q1. However, DRV8912-Q1 and DRV8910-Q1 have different functions for these addresses.

Table 51. DRV8906-Q1 Register Map (continued)

Name	7	6	5	4	3	2	1	0	Type	Address
OLD_CTRL_2	OLD_REP	OLD_OP	PL_MODE_EN		Reserved				RW	20h
OLD_CTRL_3	OCP_DEG			OLD_NEG_EN	Reserved				RW	21h
OLD_CTRL_4	Reserved		HB6_LOLD_EN	HB5_LOLD_EN	HB4_LOLD_EN	HB3_LOLD_EN	HB2_LOLD_EN	HB1_LOLD_EN	RW	22h
OLD_CTRL_5	Reserved		HB6_POLD_EN	HB5_POLD_EN	HB4_POLD_EN	HB3_POLD_EN	HB2_POLD_EN	HB1_POLD_EN	RW	23h
OLD_CTRL_6	Reserved		HB6_VM_POLD	HB5_VM_POLD	HB4_VM_POLD	HB3_VM_POLD	HB2_VM_POLD	HB1_VM_POLD	RW	24h

Table 52. DRV8904-Q1 Register Map

Name	7	6	5	4	3	2	1	0	Type	Address
IC_STAT	Reserved	OTSD	OTW	OLD	OCP	UVLO	OVP	NPOR	R	00h
OCP_STAT_1	HB4_HS_OCP	HB4_LS_OCP	HB3_HS_OCP	HB3_LS_OCP	HB2_HS_OCP	HB2_LS_OCP	HB1_HS_OCP	HB1_LS_OCP	R	01h
OCP_STAT_2	Reserved								R	02h
OCP_STAT_3	Reserved								R	03h
OLD_STAT_1	HB4_HS_OLD	HB4_LS_OLD	HB3_HS_OLD	HB3_LS_OLD	HB2_HS_OLD	HB2_LS_OLD	HB1_HS_OLD	HB1_LS_OLD	R	04h
OLD_STAT_2	Reserved								R	05h
OLD_STAT_3	Reserved								R	06h
CONFIG_CTRL	POLD_EN	IC_ID			OCP_REP	OTW_REP	EXT_OVP	CLR_FLT	RW	07h
OP_CTRL_1	HB4_HS_EN	HB4_LS_EN	HB3_HS_EN	HB3_LS_EN	HB2_HS_EN	HB2_LS_EN	HB1_HS_EN	HB1_LS_EN	RW	08h
OP_CTRL_2	Reserved								RW	09h
OP_CTRL_3	Reserved								RW	0Ah
PWM_CTRL_1	Reserved				HB4_PWM	HB3_PWM	HB2_PWM	HB1_PWM	RW	0Bh
PWM_CTRL_2	Reserved				PWM_CH4_DIS	PWM_CH3_DIS	PWM_CH2_DIS	PWM_CH1_DIS	RW	0Ch
FW_CTRL_1	Reserved				HB4_FW	HB3_FW	HB2_FW	HB1_FW	RW	0Dh
FW_CTRL_2	Reserved								RW	0Eh
PWM_MAP_CTRL_1	Reserved	HB2_PWM_MAP			HB1_PWM_MAP			RW	0Fh	
PWM_MAP_CTRL_2 ⁽¹⁾	Reserved	HB4_PWM_MAP			HB3_PWM_MAP			RW	10h ⁽¹⁾	
PWM_MAP_CTRL_3	Reserved								RW	11h
PWM_MAP_CTRL_4	Reserved								RW	12h
PWM_FREQ_CTRL_1	PWM_CH4_FREQ		PWM_CH3_FREQ		PWM_CH2_FREQ		PWM_CH1_FREQ		RW	13h
PWM_FREQ_CTRL_2	Reserved								RW	14h
PWM_DUTY_CTRL_1	PWM_DUTY_CH1								RW	15h
PWM_DUTY_CTRL_2	PWM_DUTY_CH2								RW	16h
PWM_DUTY_CTRL_3	PWM_DUTY_CH3								RW	17h
PWM_DUTY_CTRL_4	PWM_DUTY_CH4								RW	18h
PWM_DUTY_CTRL_5	Reserved								RW	19h
PWM_DUTY_CTRL_6	Reserved								RW	1Ah
PWM_DUTY_CTRL_7	Reserved								RW	1Bh
PWM_DUTY_CTRL_8	Reserved								RW	1Ch
SR_CTRL_1	Reserved				HB4_SR	HB3_SR	HB2_SR	HB1_SR	RW	1Dh
SR_CTRL_2	Reserved								RW	1Eh
OLD_CTRL_1	Reserved				HB4_OLD_DIS	HB3_OLD_DIS	HB2_OLD_DIS	HB1_OLD_DIS	RW	1Fh

(1) After this register address, the register functions are similar among DRV8908-Q1, DRV8906-Q1, and DRV8904-Q1. However, DRV8912-Q1 and DRV8910-Q1 have different functions for these addresses.

Table 52. DRV8904-Q1 Register Map (continued)

Name	7	6	5	4	3	2	1	0	Type	Address
OLD_CTRL_2	OLD_REP	OLD_OP	PL_MODE_EN		Reserved				RW	20h
OLD_CTRL_3	OCP_DEG			OLD_NEG_EN	Reserved				RW	21h
OLD_CTRL_4	Reserved				HB4_LOLD_EN	HB3_LOLD_EN	HB2_LOLD_EN	HB1_LOLD_EN	RW	22h
OLD_CTRL_5	Reserved				HB4_POLD_EN	HB3_POLD_EN	HB2_POLD_EN	HB1_POLD_EN	RW	23h
OLD_CTRL_6	Reserved				HB4_VM_POLD	HB3_VM_POLD	HB2_VM_POLD	HB1_VM_POLD	RW	24h

8.6.2.1 Status Registers

The status registers are used to report warning and fault conditions. The status registers are read-only registers.

Table 53 lists the memory-mapped registers for the status registers. All register offset addresses not listed in Table 53 should be considered as reserved locations and the register contents should not be modified.

Table 53. Status Registers Summary Table

Address	Register Name	Section
0x00	IC Status	Go
0x01	Overcurrent Protection (OCP) Status 1	Go
0x02	Overcurrent Protection (OCP) Status 2	Go
0x03	Overcurrent Protection (OCP) Status 3	Go
0x04	Open-Load Detect (OLD) Status 1	Go
0x05	Open-Load Detect (OLD) Status 2	Go
0x06	Open-Load Detect (OLD) Status 3	Go

8.6.2.1.1 IC Status (IC_STAT) Register (Address = 0x00) [reset = 0x00]

The IC status (IC_STAT) register is shown in Figure 105 and described in Table 54.

Register access type: Read only

Figure 105. IC Status Register

7	6	5	4	3	2	1	0
Reserved	OTSD	OTW	OLD	OCP	UVLO	OVP	NPOR
R-0b	R-0b	R-0b	R-0b	R-0b	R-0b	R-0b	R-0b

Table 54. IC Status Register Field Descriptions

Bit	Field	Type	Default	Description
7	Reserved	R	0b	Reserved
6	OTSD	R	0b	0b = No overtemperature shutdown is detected 1b = Overcurrent condition is detected
5	OTW	R	0b	0b = No overtemperature warning is detected 1b = Overcurrent condition is detected
4	OLD	R	0b	0b = No open-load condition is detected 1b = Open-load condition is detected
3	OCP	R	0b	0b = No overcurrent condition is detected 1b = Overcurrent condition is detected
2	UVLO	R	0b	0b = No undervoltage lock-out condition is detected 1b = Under-voltage lock-out condition condition is detected
1	OVP	R	0b	0b = No overvoltage condition is detected 1b = Overvoltage condition is detected
0	NPOR	R	0b	0b = Power-on-reset condition is detected 1b = No power-on-reset condition is detected

8.6.2.1.2 Overcurrent Protection (OCP) Status 1 (OCP_STAT_1) Register (Address = 0x01) [reset = 0x00]

 The overcurrent protection (OCP) status 1 register is shown in [Figure 106](#) and described in [Table 55](#).

Register access type: Read only

Figure 106. Overcurrent Protection (OCP) Status 1 Register

7	6	5	4	3	2	1	0
HB4_HS_OCP	HB4_LS_OCP	HB3_HS_OCP	HB3_LS_OCP	HB2_HS_OCP	HB2_LS_OCP	HB1_HS_OCP	HB1_LS_OCP
R-0b	R-0b	R-0b	R-0b	R-0b	R-0b	R-0b	R-0b

Table 55. Overcurrent Protection (OCP) Status 1 Register Field Descriptions

Bit	Field	Type	Default	Description
7	HB4_HS_OCP	R	0b	0b = No overcurrent detected on high-side switch of half-bridge 4 1b = Overcurrent detected on high-side switch of half-bridge 4
6	HB4_LS_OCP	R	0b	0b = No overcurrent detected on low-side switch of half-bridge 4 1b = Overcurrent detected on low-side switch of half-bridge 4
5	HB3_HS_OCP	R	0b	0b = No overcurrent detected on high-side switch of half-bridge 3 1b = Overcurrent detected on high-side switch of half-bridge 3
4	HB3_LS_OCP	R	0b	0b = No overcurrent detected on low-side switch of half-bridge 3 1b = Overcurrent detected on low-side switch of half-bridge 3
3	HB2_HS_OCP	R	0b	0b = No overcurrent detected on high-side switch of half-bridge 2 1b = Overcurrent detected on high-side switch of half-bridge 2
2	HB2_LS_OCP	R	0b	0b = No overcurrent detected on low-side switch of half-bridge 2 1b = Overcurrent detected on low-side switch of half-bridge 2
1	HB1_HS_OCP	R	0b	0b = No overcurrent detected on high-side switch of half-bridge 1 1b = Overcurrent detected on high-side switch of half-bridge 1
0	HB1_LS_OCP	R	0b	0b = No overcurrent detected on low-side switch of half-bridge 1 1b = Overcurrent detected on low-side switch of half-bridge 1

8.6.2.1.3 Overcurrent Protection (OCP) Status 2 (OCP_STAT_2) Register (Address = 0x02) [reset = 0x00]

The overcurrent protection (OCP) status 2 register is shown in [Figure 107](#) and described in [Table 56](#).

Register access type: Read only

Figure 107. Overcurrent Protection (OCP) Status 2 Register

7	6	5	4	3	2	1	0
HB8_HS_OCP	HB8_LS_OCP	HB7_HS_OCP	HB7_LS_OCP	HB6_HS_OCP	HB6_LS_OCP	HB5_HS_OCP	HB5_LS_OCP
R-0b	R-0b	R-0b	R-0b	R-0b	R-0b	R-0b	R-0b

Table 56. Overcurrent Protection (OCP) Status 2 Register Field Descriptions

Bit	Field	Type	Default	Description
7	HB8_HS_OCP	R	0b	0b = No overcurrent detected on high-side switch of half-bridge 8 1b = Overcurrent detected on high-side switch of half-bridge 8
6	HB8_LS_OCP	R	0b	0b = No overcurrent detected on low-side switch of half-bridge 8 1b = Overcurrent detected on low-side switch of half-bridge 8
5	HB7_HS_OCP	R	0b	0b = No overcurrent detected on high-side switch of half-bridge 7 1b = Overcurrent detected on high-side switch of half-bridge 7
4	HB7_LS_OCP	R	0b	0b = No overcurrent detected on low-side switch of half-bridge 7 1b = Overcurrent detected on low-side switch of half-bridge 7
3	HB6_HS_OCP	R	0b	0b = No overcurrent detected on high-side switch of half-bridge 6 1b = Overcurrent detected on high-side switch of half-bridge 6
2	HB6_LS_OCP	R	0b	0b = No overcurrent detected on low-side switch of half-bridge 6 1b = Overcurrent detected on low-side switch of half-bridge 6
1	HB5_HS_OCP	R	0b	0b = No overcurrent detected on high-side switch of half-bridge 5 1b = Overcurrent detected on high-side switch of half-bridge 5
0	HB5_LS_OCP	R	0b	0b = No overcurrent detected on low-side switch of half-bridge 5 1b = Overcurrent detected on low-side switch of half-bridge 5

8.6.2.1.4 Overcurrent Protection (OCP) Status 3 (OCP_STAT_3) Register (Address = 0x03) [reset = 0x00]

The overcurrent protection (OCP) status 3 register is shown in [Figure 108](#) and described in [Table 57](#).

Register access type: Read only

Figure 108. Overcurrent Protection (OCP) Status 3 Register

7	6	5	4	3	2	1	0
Reserved							
R-0b	R-0b	R-0b	R-0b	R-0b	R-0b	R-0b	R-0b

Table 57. Overcurrent Protection (OCP) Status 3 Register Field Descriptions

Bit	Field	Type	Default	Description
7-0	Reserved	R	0b	Reserved.

8.6.2.1.5 Open-Load Detect (OLD) Status 1 (OLD_STAT_1) Register (Address = 0x04) [reset = 0x00]

 The open-load detect (OLD) status 1 register is shown in [Figure 109](#) and described in [Table 58](#).

Register access type: Read only

Figure 109. Open-Load Detect (OLD) Status 1 Register

7	6	5	4	3	2	1	0
HB4_HS_OLD	HB4_LS_OLD	HB3_HS_OLD	HB3_LS_OLD	HB2_HS_OLD	HB2_LS_OLD	HB1_HS_OLD	HB1_LS_OLD
R-0b	R-0b	R-0b	R-0b	R-0b	R-0b	R-0b	R-0b

Table 58. Open-Load Detect (OLD) Status 1 Register Field Descriptions

Bit	Field	Type	Default	Description
7	HB4_HS_OLD	R	0b	0b = No open load detected on high-side switch of half-bridge 4 1b = Open load detected on high-side switch of half-bridge 4
6	HB4_LS_OLD	R	0b	0b = No open load detected on low-side switch of half-bridge 4 1b = Open load detected on low-side switch of half-bridge 4
5	HB3_HS_OLD	R	0b	0b = No open load detected on high-side switch of half-bridge 3 1b = Open load detected on high-side switch of half-bridge 3
4	HB3_LS_OLD	R	0b	0b = No open load detected on low-side switch of half-bridge 3 1b = Open load detected on low-side switch of half-bridge 3
3	HB2_HS_OLD	R	0b	0b = No open load detected on high-side switch of half-bridge 2 1b = Open load detected on high-side switch of half-bridge 2
2	HB2_LS_OLD	R	0b	0b = No open load detected on low-side switch of half-bridge 2 1b = Open load detected on low-side switch of half-bridge 2
1	HB1_HS_OLD	R	0b	0b = No open load detected on high-side switch of half-bridge 1 1b = Open load detected on high-side switch of half-bridge 1
0	HB1_LS_OLD	R	0b	0b = No open load detected on low-side switch of half-bridge 1 1b = Open load detected on low-side switch of half-bridge 1

8.6.2.1.6 Open-Load Detect (OLD) Status 2 (OLD_STAT_2) Register (Address = 0x05) [reset = 0x00]

The open-load detect (OLD) status 2 register is shown in [Figure 110](#) and described in [Table 59](#).

Register access type: Read only

Figure 110. Open-Load Detect (OLD) Status 2 Register

7	6	5	4	3	2	1	0
HB8_HS_OLD	HB8_LS_OLD	HB7_HS_OLD	HB7_LS_OLD	HB6_HS_OLD	HB6_LS_OLD	HB5_HS_OLD	HB5_LS_OLD
R-0b	R-0b	R-0b	R-0b	R-0b	R-0b	R-0b	R-0b

Table 59. Open-Load Detect (OLD) Status 2 Register Field Descriptions

Bit	Field	Type	Default	Description
7	HB8_HS_OLD	R	0b	0b = No open load detected on high-side switch of half-bridge 8 1b = Open load detected on high-side switch of half-bridge 8
6	HB8_LS_OLD	R	0b	0b = No open load detected on low-side switch of half-bridge 8 1b = Open load detected on low-side switch of half-bridge 8
5	HB7_HS_OLD	R	0b	0b = No open load detected on high-side switch of half-bridge 7 1b = Open load detected on high-side switch of half-bridge 7
4	HB7_LS_OLD	R	0b	0b = No open load detected on low-side switch of half-bridge 7 1b = Open load detected on low-side switch of half-bridge 7
3	HB6_HS_OLD	R	0b	0b = No open load detected on high-side switch of half-bridge 6 1b = Open load detected on high-side switch of half-bridge 6
2	HB6_LS_OLD	R	0b	0b = No open load detected on low-side switch of half-bridge 6 1b = Open load detected on low-side switch of half-bridge 6
1	HB5_HS_OLD	R	0b	0b = No open load detected on high-side switch of half-bridge 5 1b = Open load detected on high-side switch of half-bridge 5
0	HB5_LS_OLD	R	0b	0b = No open load detected on low-side switch of half-bridge 5 1b = Open load detected on low-side switch of half-bridge 5

8.6.2.1.7 Open-Load Detect (OLD) Status 3 (OLD_STAT_3) Register (Address = 0x06) [reset = 0x00]

The open-load detect (OLD) status 3 register is shown in [Figure 111](#) and described in [Table 60](#).

Register access type: Read only

Figure 111. Open-Load Detect (OLD) Status 3 Register

7	6	5	4	3	2	1	0
Reserved							
R-0b	R-0b	R-0b	R-0b	R-0b	R-0b	R-0b	R-0b

Table 60. Open-Load Detect (OLD) Status 3 Register Field Descriptions

Bit	Field	Type	Default	Description
7-0	Reserved	R	0b	Reserved.

8.6.2.2 Control Registers

The control registers are used to configure the device. The control registers are read and write capable.

[Table 61](#) lists the memory-mapped registers for the control registers. All register offset addresses not listed in [Table 61](#) should be considered as reserved locations and the register contents should not be modified.

Table 61. Control Registers Summary Table

Address	Register Name	Section
0x07	Configuration Register	Go
0x08	Operation Control 1 Register	Go
0x09	Operation Control 2 Register	Go
0x0A	Operation Control 3 Register	Go
0x0B	PWM Control 1 Register	Go
0x0C	PWM Control 2 Register	Go
0x0D	Free-Wheeling Control 1 Register	Go
0x0E	Free-Wheeling Control 2 Register	Go
0x0F	PWM Map Control 1 Register	Go
0x10	PWM Map Control 2 Register	Go
0x11	PWM Map Control 3 Register	Go
0x12	PWM Map Control 4 Register	Go
0x13	PWM Frequency Control 1 Register	Go
0x14	PWM Frequency Control 2 Register	Go
0x15	PWM Duty Control Channel 1 Register	Go
0x16	PWM Duty Control Channel 2 Register	Go
0x17	PWM Duty Control Channel 3 Register	Go
0x18	PWM Duty Control Channel 4 Register	Go
0x19	PWM Duty Control Channel 5 Register	Go
0x1A	PWM Duty Control Channel 6 Register	Go
0x1B	PWM Duty Control Channel 7 Register	Go
0x1C	PWM Duty Control Channel 8 Register	Go
0x1D	Slew Rate Control 1 Register	Go
0x1E	Slew Rate Control 2 Register	Go
0x1F	Open-Load Detect (OLD) Control 1 Register	Go
0x20	Open-Load Detect (OLD) Control 2 Register	Go
0x21	Open-Load Detect (OLD) Control 3 Register	Go
0x22	Open-Load Detect (OLD) Control 4 Register	Go
0x23	Open-Load Detect (OLD) Control 5 Register	Go
0x24	Open-Load Detect (OLD) Control 6 Register	Go

8.6.2.2.1 Configuration (CONFIG_CTRL) Register (Address = 0x07) [reset = 0x00]

The configuration register is shown in Figure 112 and described in Table 62.

Register access type: Read/Write

Figure 112. Configuration Register

7	6	5	4	3	2	1	0
POLD_EN		IC_ID		OCP_REP	OTW_REP	EXT_OVP	CLR_FLT
R/W-0b	R-Xb	R-Xb	R-Xb	R/W-0b	R/W-0b	R/W-0b	R/W-0b

Table 62. Configuration Register Field Descriptions

Bit	Field	Type	Default	Description
7	POLD_EN	R/W	0b	0b = Passive OLD is disabled 1b = Passive OLD is enabled
6-4	IC_ID	R	XXXb	000b = Device connected is DRV8912-Q1 (12 Channel Device) 001b = Device connected is DRV8910-Q1 (10 Channel Device) 010b = Device connected is DRV8908-Q1 (8 Channel Device) 011b = Device connected is DRV8906-Q1 (6 Channel Device) 100b = Device connected is DRV8904-Q1 (4 Channel Device) 101b = Reserved 110b = Reserved 111b = Reserved
3	OCP_REP	R/W	0b	0b = Overcurrent condition is reported in nFAULT pin 1b = Overcurrent condition warning is not reported on the nFAULT pin
2	OTW_REP	R/W	0b	0b = Overtemperature warning is not reported in nFAULT pin 1b = Overtemperature warning is reported on the nFAULT pin
1	EXT_OVP	R/W	0b	0b = Overvoltage protection threshold is at 21 V 1b = Overvoltage protection threshold is at 33 V
0	CLR_FLT	R/W	0b	0b = Faults not cleared 1b = Clear all faults

NOTE

CLR_FLT bit is an auto-clear bit and will always read 0b.

8.6.2.2.2 Operation Control 1 (OP_CTRL_1) Register (Address = 0x08) [reset = 0x00]

 The operation control 1 register is shown in [Figure 113](#) and described in [Table 63](#).

Register access type: Read/Write

Figure 113. Operation Control 1 Register

7	6	5	4	3	2	1	0
HB4_HS_EN	HB4_LS_EN	HB3_HS_EN	HB3_LS_EN	HB2_HS_EN	HB2_LS_EN	HB1_HS_EN	HB1_LS_EN
R/W-0b	R/W-0b	R/W-0b	R/W-0b	R/W-0b	R/W-0b	R/W-0b	R/W-0b

Table 63. Operation Control 1 Register Field Descriptions

Bit	Field	Type	Default	Description
7	HB4_HS_EN	R/W	0b	0b = Half-bridge 4 high-side switch is disabled 1b = Half-bridge 4 high-side switch is enabled
6	HB4_LS_EN	R/W	0b	0b = Half-bridge 4 low-side switch is disabled 1b = Half-bridge 4 low-side switch is enabled
5	HB3_HS_EN	R/W	0b	0b = Half-bridge 3 high-side switch is disabled 1b = Half-bridge 3 high-side switch is enabled
4	HB3_LS_EN	R/W	0b	0b = Half-bridge 3 low-side switch is disabled 1b = Half-bridge 3 low-side switch is enabled
3	HB2_HS_EN	R/W	0b	0b = Half-bridge 2 high-side switch is disabled 1b = Half-bridge 2 high-side switch is enabled
2	HB2_LS_EN	R/W	0b	0b = Half-bridge 2 low-side switch is disabled 1b = Half-bridge 2 low-side switch is enabled
1	HB1_HS_EN	R/W	0b	0b = Half-bridge 1 high-side switch is disabled 1b = Half-bridge 1 high-side switch is enabled
0	HB1_LS_EN	R/W	0b	0b = Half-bridge 1 low-side switch is disabled 1b = Half-bridge 1 low-side switch is enabled

8.6.2.2.3 Operation Control 2 (OP_CTRL_2) Register (Address = 0x09) [reset = 0x00]

The operation control 2 register is shown in [Figure 114](#) and described in [Table 64](#).

Register access type: Read/Write

Figure 114. Operation Control 2 Register

7	6	5	4	3	2	1	0
HB8_HS_EN	HB8_LS_EN	HB7_HS_EN	HB7_LS_EN	HB6_HS_EN	HB6_LS_EN	HB5_HS_EN	HB5_LS_EN
R/W-0b	R/W-0b	R/W-0b	R/W-0b	R/W-0b	R/W-0b	R/W-0b	R/W-0b

Table 64. Operation Control 2 Register Field Descriptions

Bit	Field	Type	Default	Description
7	HB8_HS_EN	R/W	0b	0b = Half-bridge 8 high-side switch is disabled 1b = Half-bridge 8 high-side switch is enabled
6	HB8_LS_EN	R/W	0b	0b = Half-bridge 8 low-side switch is disabled 1b = Half-bridge 8 low-side switch is enabled
5	HB7_HS_EN	R/W	0b	0b = Half-bridge 7 high-side switch is disabled 1b = Half-bridge 7 high-side switch is enabled
4	HB7_LS_EN	R/W	0b	0b = Half-bridge 7 low-side switch is disabled 1b = Half-bridge 7 low-side switch is enabled
3	HB6_HS_EN	R/W	0b	0b = Half-bridge 6 high-side switch is disabled 1b = Half-bridge 6 high-side switch is enabled
2	HB6_LS_EN	R/W	0b	0b = Half-bridge 6 low-side switch is disabled 1b = Half-bridge 6 low-side switch is enabled
1	HB5_HS_EN	R/W	0b	0b = Half-bridge 5 high-side switch is disabled 1b = Half-bridge 5 high-side switch is enabled
0	HB5_LS_EN	R/W	0b	0b = Half-bridge 5 low-side switch is disabled 1b = Half-bridge 5 low-side switch is enabled

8.6.2.2.4 Operation Control 3 (OP_CTRL_3) Register (Address = 0x0A) [reset = 0x00]

The operation control 3 register is shown in [Figure 115](#) and described in [Table 65](#).

Register access type: Read

Figure 115. Operation Control 3 Register

7	6	5	4	3	2	1	0
Reserved							
R-0b	R-0b	R-0b	R-0b	R-0b	R-0b	R-0b	R-0b

Table 65. Operation Control 3 Register Field Descriptions

Bit	Field	Type	Default	Description
7-0	Reserved	R	0b	Reserved.

8.6.2.2.5 PWM Control 1 (PWM_CTRL_1) Register (Address = 0x0B) [reset = 0x00]

 The PWM control 1 register is shown in [Figure 116](#) and described in [Table 66](#).

Register access type: Read/Write

Figure 116. PWM Control 1 Register

7	6	5	4	3	2	1	0
HB8_PWM	HB7_PWM	HB6_PWM	HB5_PWM	HB4_PWM	HB3_PWM	HB2_PWM	HB1_PWM
R/W-0b	R/W-0b	R/W-0b	R/W-0b	R/W-0b	R/W-0b	R/W-0b	R/W-0b

Table 66. PWM Control 1 Register Field Descriptions

Bit	Field	Type	Default	Description
7	HB8_PWM	R/W	0b	0b = Half-bridge 8 is operating in continuous mode 1b = Half-bridge 8 is operating in PWM mode
6	HB7_PWM	R/W	0b	0b = Half-bridge 7 is operating in continuous mode 1b = Half-bridge 7 is operating in PWM mode
5	HB6_PWM	R/W	0b	0b = Half-bridge 6 is operating in continuous mode 1b = Half-bridge 6 is operating in PWM mode
4	HB5_PWM	R/W	0b	0b = Half-bridge 5 is operating in continuous mode 1b = Half-bridge 5 is operating in PWM mode
3	HB4_PWM	R/W	0b	0b = Half-bridge 4 is operating in continuous mode 1b = Half-bridge 4 is operating in PWM mode
2	HB3_PWM	R/W	0b	0b = Half-bridge 3 is operating in continuous mode 1b = Half-bridge 3 is operating in PWM mode
1	HB2_PWM	R/W	0b	0b = Half-bridge 2 is operating in continuous mode 1b = Half-bridge 2 is operating in PWM mode
0	HB1_PWM	R/W	0b	0b = Half-bridge 1 is operating in continuous mode 1b = Half-bridge 1 is operating in PWM mode

8.6.2.2.6 PWM Control 2 (PWM_CTRL_2) Register (Address = 0x0C) [reset = 0x00]

The PWM control 2 register is shown in [Figure 117](#) and described in [Table 67](#).

Register access type: Read/Write

Figure 117. PWM Control 2 Register

7	6	5	4	3	2	1	0
PWM_CH8_DI S	PWM_CH7_DI S	PWM_CH6_DI S	PWM_CH5_DI S	PWM_CH4_DI S	PWM_CH3_DI S	PWM_CH2_DI S	PWM_CH1_DI S
R/W-0b	R/W-0b	R/W-0b	R/W-0b	R/W-0b	R/W-0b	R/W-0b	R/W-0b

Table 67. PWM Control 2 Register Field Descriptions

Bit	Field	Type	Default	Description
7	PWM_CH8_DIS	R/W	0b	0b = PWM Generator-8 is enabled 1b = PWM Generator-8 is disabled
6	PWM_CH7_DIS	R/W	0b	0b = PWM Generator-7 is enabled 1b = PWM Generator-7 is disabled
5	PWM_CH6_DIS	R/W	0b	0b = PWM Generator-6 is enabled 1b = PWM Generator-6 is disabled
4	PWM_CH5_DIS	R/W	0b	0b = PWM Generator-5 is enabled 1b = PWM Generator-5 is disabled
3	PWM_CH4_DIS	R/W	0b	0b = PWM Generator-4 is enabled 1b = PWM Generator-4 is disabled
2	PWM_CH3_DIS	R/W	0b	0b = PWM Generator-3 is enabled 1b = PWM Generator-3 is disabled
1	PWM_CH2_DIS	R/W	0b	0b = PWM Generator-2 is enabled 1b = PWM Generator-2 is disabled
0	PWM_CH1_DIS	R/W	0b	0b = PWM Generator-1 is enabled 1b = PWM Generator-1 is disabled

8.6.2.2.7 Free-Wheeling Control 1 (FW_CTRL_1) Register (Address = 0x0D) [reset = 0x00]

The free-wheeling control 1 register is shown in [Figure 118](#) and described in [Table 68](#).

Register access type: Read/Write

Figure 118. Free-Wheeling Control 1 Register

7	6	5	4	3	2	1	0
HB8_FW	HB7_FW	HB6_FW	HB5_FW	HB4_FW	HB3_FW	HB2_FW	HB1_FW
R/W-0b	R/W-0b	R/W-0b	R/W-0b	R/W-0b	R/W-0b	R/W-0b	R/W-0b

Table 68. Free-Wheeling Control 1 Register Field Descriptions

Bit	Field	Type	Default	Description
7	HB8_FW	R/W	0b	0b = Passive free-wheeling on half-bridge 8 is enabled 1b = Active free-wheeling on half-bridge 8 is enabled
6	HB7_FW	R/W	0b	0b = Passive free-wheeling on half-bridge 7 is enabled 1b = Active free-wheeling on half-bridge 7 is enabled
5	HB6_FW	R/W	0b	0b = Passive free-wheeling on half-bridge 6 is enabled 1b = Active free-wheeling on half-bridge 6 is enabled
4	HB5_FW	R/W	0b	0b = Passive free-wheeling on half-bridge 5 is enabled 1b = Active free-wheeling on half-bridge 5 is enabled
3	HB4_FW	R/W	0b	0b = Passive free-wheeling on half-bridge 4 is enabled 1b = Active free-wheeling on half-bridge 4 is enabled
2	HB3_FW	R/W	0b	0b = Passive free-wheeling on half-bridge 3 is enabled 1b = Active free-wheeling on half-bridge 3 is enabled
1	HB2_FW	R/W	0b	0b = Passive free-wheeling on half-bridge 2 is enabled 1b = Active free-wheeling on half-bridge 2 is enabled
0	HB1_FW	R/W	0b	0b = Passive free-wheeling on half-bridge 1 is enabled 1b = Active free-wheeling on half-bridge 1 is enabled

8.6.2.2.8 Free-Wheeling Control 2 (FW_CTRL_2) Register (Address = 0x0E) [reset = 0x00]

The free-wheeling control 2 register is shown in [Figure 119](#) and described in [Table 69](#).

Register access type: Read/Write

Figure 119. Free-Wheeling Control 2 Register

7	6	5	4	3	2	1	0
Reserved							
R/W-0b	R/W-0b	R/W-0b	R/W-0b	R/W-0b	R/W-0b	R/W-0b	R/W-0b

Table 69. Free-Wheeling Control 2 Register Field Descriptions

Bit	Field	Type	Default	Description
7-0	Reserved	R/W	0000b	Reserved.

8.6.2.2.9 PWM Map Control 1 (PWM_MAP_CTRL_1) Register (Address = 0x0F) [reset = 0x00]

The PWM Map Control 1 register is shown in Figure 120 and described in Table 70.

Register access type: Read/Write

Figure 120. PWM Map Control 1 Register

7	6	5	4	3	2	1	0
Reserved		HB2_PWM_MAP			HB1_PWM_MAP		
R/W-0b	R/W-0b	R/W-0b	R/W-0b	R/W-0b	R/W-0b	R/W-0b	R/W-0b

Table 70. PWM Map Control 1 Register Field Descriptions

Bit	Field	Type	Default	Description
7-6	Reserved	R	00b	Reserved
3-2	HB2_PWM_MAP	R/W	000b	00b = HB2 mapped to PWM channel 1 001b = HB2 mapped to PWM channel 2 010b = HB2 mapped to PWM channel 3 011b = HB2 mapped to PWM channel 4 100b = HB2 mapped to PWM channel 5 101b = HB2 mapped to PWM channel 6 110b = HB mapped to PWM channel 7 111b = HB2 mapped to PWM channel 8
1-0	HB1_PWM_MAP	R/W	000b	00b = HB1 mapped to PWM channel 1 001b = HB1 mapped to PWM channel 2 010b = HB1 mapped to PWM channel 3 011b = HB1 mapped to PWM channel 4 100b = HB1 mapped to PWM channel 5 101b = HB1 mapped to PWM channel 6 110b = HB1 mapped to PWM channel 7 111b = HB1 mapped to PWM channel 8

8.6.2.2.10 PWM Map Control 2 (PWM_MAP_CTRL_2) Register (Address = 0x10) [reset = 0x00]

The PWM frequency map control 2 register is shown in [Figure 121](#) and described in [Table 71](#).

Register access type: Read/Write

Figure 121. PWM Map Control 2 Register

7	6	5	4	3	2	1	0
Reserved		HB4_PWM_MAP			HB3_PWM_MAP		
R/W-0b	R/W-0b	R/W-0b	R/W-0b	R/W-0b	R/W-0b	R/W-0b	R/W-0b

Table 71. PWM Map Control 2 Register Field Descriptions

Bit	Field	Type	Default	Description
7-6	Reserved	R	00b	Reserved
3-2	HB4_PWM_MAP	R/W	000b	00b = HB4 mapped to PWM channel 1 001b = HB4 mapped to PWM channel 2 010b = HB4 mapped to PWM channel 3 011b = HB4 mapped to PWM channel 4 100b = HB4 mapped to PWM channel 5 101b = HB4 mapped to PWM channel 6 110b = HB4 mapped to PWM channel 7 111b = HB4 mapped to PWM channel 8
1-0	HB3_PWM_MAP	R/W	000b	00b = HB3 mapped to PWM channel 1 001b = HB3 mapped to PWM channel 2 010b = HB3 mapped to PWM channel 3 011b = HB3 mapped to PWM channel 4 100b = HB3 mapped to PWM channel 5 101b = HB3 mapped to PWM channel 6 110b = HB3 mapped to PWM channel 7 111b = HB3 mapped to PWM channel 8

8.6.2.2.11 PWM Map Control 3 (PWM_MAP_CTRL_3) Register (Address = 0x11) [reset = 0x00]

The PWM frequency map control 3 register is shown in [Figure 122](#) and described in [Table 72](#).

Register access type: Read/Write

Figure 122. PWM Map Control 3 Register

7	6	5	4	3	2	1	0
Reserved		HB6_PWM_MAP			HB5_PWM_MAP		
R/W-0b	R/W-0b	R/W-0b	R/W-0b	R/W-0b	R/W-0b	R/W-0b	R/W-0b

Table 72. PWM Map Control 3 Register Field Descriptions

Bit	Field	Type	Default	Description
7-6	Reserved	R	00b	Reserved
3-2	HB6_PWM_MAP	R/W	000b	00b = HB6 mapped to PWM channel 1 01b = HB6 mapped to PWM channel 2 10b = HB6 mapped to PWM channel 3 11b = HB6 mapped to PWM channel 4 01b = HB6 mapped to PWM channel 5 10b = HB6 mapped to PWM channel 6 11b = HB6 mapped to PWM channel 7 01b = HB6 mapped to PWM channel 8
1-0	HB5_PWM_MAP	R/W	000b	00b = HB5 mapped to PWM channel 1 01b = HB5 mapped to PWM channel 2 10b = HB5 mapped to PWM channel 3 11b = HB5 mapped to PWM channel 4 01b = HB5 mapped to PWM channel 5 10b = HB5 mapped to PWM channel 6 11b = HB5 mapped to PWM channel 7 01b = HB5 mapped to PWM channel 8

8.6.2.2.12 PWM Map Control 4 (PWM_MAP_CTRL_4) Register (Address = 0x12) [reset = 0x00]

 The PWM frequency map control 4 register is shown in [Figure 123](#) and described in [Table 73](#).

Register access type: Read/Write

Figure 123. PWM Map Control 4 Register

7	6	5	4	3	2	1	0
Reserved		HB8_PWM_MAP			HB7_PWM_MAP		
R/W-0b	R/W-0b	R/W-0b	R/W-0b	R/W-0b	R/W-0b	R/W-0b	R/W-0b

Table 73. PWM Map Control 4 Register Field Descriptions

Bit	Field	Type	Default	Description
7-6	Reserved	R	00b	Reserved
3-2	HB8_PWM_MAP	R/W	000b	00b = HB8 mapped to PWM channel 1 01b = HB8 mapped to PWM channel 2 10b = HB8 mapped to PWM channel 3 11b = HB8 mapped to PWM channel 4 01b = HB8 mapped to PWM channel 5 10b = HB8 mapped to PWM channel 6 11b = HB8 mapped to PWM channel 7 01b = HB8 mapped to PWM channel 8
1-0	HB7_PWM_MAP	R/W	000b	00b = HB7 mapped to PWM channel 1 01b = HB7 mapped to PWM channel 2 10b = HB7 mapped to PWM channel 3 11b = HB7 mapped to PWM channel 4 01b = HB7 mapped to PWM channel 5 10b = HB7 mapped to PWM channel 6 11b = HB7 mapped to PWM channel 7 01b = HB7 mapped to PWM channel 8

8.6.2.2.13 PWM Frequency Control 1 (PWM_FREQ_CTRL_1) Register (Address = 0x13 [reset = 0x00])

The PWM frequency control register 1 is shown in [Figure 124](#) and described in [Table 74](#).

Register access type: Read/Write

Figure 124. PWM Frequency Control 1 Register

7	6	5	4	3	2	1	0
PWM_CH4_FREQ		PWM_CH3_FREQ		PWM_CH2_FREQ		PWM_CH1_FREQ	
R/W-0b	R/W-0b	R/W-0b	R/W-0b	R/W-0b	R/W-0b	R/W-0b	R/W-0b

Table 74. PWM Frequency Control 1 Register Field Descriptions

Bit	Field	Type	Default	Description
7-6	PWM_CH4_FREQ	R/W	00b	00b = PWM frequency is 80 Hz 01b = PWM frequency is 100 Hz 10b = PWM frequency is 200 Hz 11b = PWM frequency is 2000 Hz
5-4	PWM_CH3_FREQ	R/W	00b	00b = PWM frequency is 80 Hz 01b = PWM frequency is 100 Hz 10b = PWM frequency is 200 Hz 11b = PWM frequency is 2000 Hz
3-2	PWM_CH2_FREQ	R/W	00b	00b = PWM frequency is 80 Hz 01b = PWM frequency is 100 Hz 10b = PWM frequency is 200 Hz 11b = PWM frequency is 2000 Hz
1-0	PWM_CH1_FREQ	R/W	00b	00b = PWM frequency is 80 Hz 01b = PWM frequency is 100 Hz 10b = PWM frequency is 200 Hz 11b = PWM frequency is 2000 Hz

8.6.2.2.14 PWM Frequency Control 2 (PWM_FREQ_CTRL_2) Register (Address = 0x14 [reset = 0x00])

 The PWM frequency control register 2 is shown in [Figure 125](#) and described in [Table 75](#).

Register access type: Read/Write

Figure 125. PWM Frequency Control 2 Register

7	6	5	4	3	2	1	0
PWM_CH8_FREQ		PWM_CH7_FREQ		PWM_CH6_FREQ		PWM_CH5_FREQ	
R/W-0b	R/W-0b	R/W-0b	R/W-0b	R/W-0b	R/W-0b	R/W-0b	R/W-0b

Table 75. PWM Frequency Control 2 Register Field Descriptions

Bit	Field	Type	Default	Description
7-6	PWM_CH8_FREQ	R/W	00b	00b = PWM frequency is 80 Hz 01b = PWM frequency is 100 Hz 10b = PWM frequency is 200 Hz 11b = PWM frequency is 2000 Hz
5-4	PWM_CH7_FREQ	R/W	00b	00b = PWM frequency is 80 Hz 01b = PWM frequency is 100 Hz 10b = PWM frequency is 200 Hz 11b = PWM frequency is 2000 Hz
3-2	PWM_CH6_FREQ	R/W	00b	00b = PWM frequency is 80 Hz 01b = PWM frequency is 100 Hz 10b = PWM frequency is 200 Hz 11b = PWM frequency is 2000 Hz
1-0	PWM_CH5_FREQ	R/W	00b	00b = PWM frequency is 80 Hz 01b = PWM frequency is 100 Hz 10b = PWM frequency is 200 Hz 11b = PWM frequency is 2000 Hz

8.6.2.2.15 PWM Duty Control Channel 1 (PWM_DUTY_CH1) Register (Address = 0x15) [reset = 0x00]

The channel 1 PWM duty cycle control register is shown in Figure 126 and described in Table 76.

Register access type: Read/Write

Figure 126. PWM Duty Control Channel 1 Register

7	6	5	4	3	2	1	0
PWM_DUTY_CH1							
R/W-0b	R/W-0b	R/W-0b	R/W-0b	R/W-0b	R/W-0b	R/W-0b	R/W-0b

Table 76. PWM Duty Control Channel 1 Register Field Descriptions

Bit	Field	Type	Default	Description
7-0	PWM_DUTY_CH1	R/W	00000000b	00000000b = 0 % PWM Duty 11111111b = 100 % PWM Duty Calculate duty as decimal (xxxxxxx) × 1/255

8.6.2.2.16 PWM Duty Control Channel 2 (PWM_DUTY_CH2) Register (Address = 0x16) [reset = 0x00]

The channel 2 PWM duty cycle control register is shown in Figure 127 and described in Table 77.

Register access type: Read/Write

Figure 127. PWM Duty Control Channel 2 Register

7	6	5	4	3	2	1	0
PWM_DUTY_CH2							
R/W-0b	R/W-0b	R/W-0b	R/W-0b	R/W-0b	R/W-0b	R/W-0b	R/W-0b

Table 77. PWM Duty Control Channel 2 Register Field Descriptions

Bit	Field	Type	Default	Description
7-0	PWM_DUTY_CH2	R/W	00000000b	00000000b = 0 % PWM Duty 11111111b = 100 % PWM Duty Calculate duty as decimal (xxxxxxx) × 1/255

8.6.2.2.17 PWM Duty Control Channel 3 (PWM_DUTY_CH3) Register (Address = 0x17) [reset = 0x00]

The channel 3 PWM duty cycle control register is shown in [Figure 128](#) and described in [Table 78](#).

Register access type: Read/Write

Figure 128. PWM Duty Control Channel 3 Register

7	6	5	4	3	2	1	0
PWM_DUTY_CH3							
R/W-0b	R/W-0b	R/W-0b	R/W-0b	R/W-0b	R/W-0b	R/W-0b	R/W-0b

Table 78. PWM Duty Control Channel 3 Register Field Descriptions

Bit	Field	Type	Default	Description
7-0	PWM_DUTY_CH3	R/W	00000000b	00000000b = 0 % PWM Duty 11111111b = 100 % PWM Duty Calculate duty as decimal (xxxxxxx) × 1/255

8.6.2.2.18 PWM Duty Control Channel 4 (PWM_DUTY_CH4) Register (Address = 0x18) [reset = 0x00]

The channel 4 PWM duty cycle control register is shown in [Figure 129](#) and described in [Table 79](#).

Register access type: Read/Write

Figure 129. PWM Duty Control Channel 4 Register

7	6	5	4	3	2	1	0
PWM_DUTY_CH4							
R/W-0b	R/W-0b	R/W-0b	R/W-0b	R/W-0b	R/W-0b	R/W-0b	R/W-0b

Table 79. PWM Duty Control Channel 4 Register Field Descriptions

Bit	Field	Type	Default	Description
7-0	PWM_DUTY_CH4	R/W	00000000b	00000000b = 0 % PWM Duty 11111111b = 100 % PWM Duty Calculate duty as decimal (xxxxxxx) × 1/255

8.6.2.2.19 PWM Duty Control Channel 5 (PWM_DUTY_CH5) Register (Address = 0x19) [reset = 0x00]

The channel 5 PWM duty cycle control register is shown in [Figure 130](#) and described in [Table 80](#).

Register access type: Read/Write

Figure 130. PWM Duty Control Channel 5 Register

7	6	5	4	3	2	1	0
PWM_DUTY_CH5							
R/W-0b	R/W-0b	R/W-0b	R/W-0b	R/W-0b	R/W-0b	R/W-0b	R/W-0b

Table 80. PWM Duty Control Channel 5 Register Field Descriptions

Bit	Field	Type	Default	Description
7-0	PWM_DUTY_CH5	R/W	00000000b	00000000b = 0 % PWM Duty 11111111b = 100 % PWM Duty Calculate duty as decimal (xxxxxxx) × 1/255

8.6.2.2.20 PWM Duty Control Channel 6 (PWM_DUTY_CH6) Register (Address = 0x1A) [reset = 0x00]

The channel 6 PWM duty cycle control register is shown in [Figure 131](#) and described in [Table 81](#).

Register access type: Read/Write

Figure 131. PWM Duty Control Channel 6 Register

7	6	5	4	3	2	1	0
PWM_DUTY_CH6							
R/W-0b	R/W-0b	R/W-0b	R/W-0b	R/W-0b	R/W-0b	R/W-0b	R/W-0b

Table 81. PWM Duty Control Channel 6 Register Field Descriptions

Bit	Field	Type	Default	Description
7-0	PWM_DUTY_CH6	R/W	00000000b	00000000b = 0 % PWM Duty 11111111b = 100 % PWM Duty Calculate duty as decimal (xxxxxxx) × 1/255

8.6.2.2.21 PWM Duty Control Channel 7 (PWM_DUTY_CH7) Register (Address = 0x1B) [reset = 0x00]

The channel 7 PWM duty cycle control register is shown in [Figure 132](#) and described in [Table 82](#).

Register access type: Read/Write

Figure 132. PWM Duty Control Channel 7 Register

7	6	5	4	3	2	1	0
PWM_DUTY_CH7							
R/W-0b	R/W-0b	R/W-0b	R/W-0b	R/W-0b	R/W-0b	R/W-0b	R/W-0b

Table 82. PWM Duty Control Channel 7 Register Field Descriptions

Bit	Field	Type	Default	Description
7-0	PWM_DUTY_CH7	R/W	00000000b	00000000b = 0 % PWM Duty 11111111b = 100 % PWM Duty Calculate duty as decimal (xxxxxxx) × 1/255

8.6.2.2.22 PWM Duty Control Channel 8 (PWM_DUTY_CH8) Register (Address = 0x1C) [reset = 0x00]

The channel 8 PWM duty cycle control register is shown in [Figure 133](#) and described in [Table 83](#).

Register access type: Read/Write

Figure 133. PWM Duty Control Channel 8 Register

7	6	5	4	3	2	1	0
PWM_DUTY_CH4							
R/W-0b	R/W-0b	R/W-0b	R/W-0b	R/W-0b	R/W-0b	R/W-0b	R/W-0b

Table 83. PWM Duty Control Channel 8 Register Field Descriptions

Bit	Field	Type	Default	Description
7-0	PWM_DUTY_CH8	R/W	00000000b	00000000b = 0 % PWM Duty 11111111b = 100 % PWM Duty Calculate duty as decimal (xxxxxxx) × 1/255

8.6.2.2.23 Slew Rate Control 1 (SR_CTRL_1) Register (Address = 0x1D [reset = 0x00])

The slew rate control 1 register is shown in [Figure 134](#) and described in [Table 84](#).

Register access type: Read/Write

Figure 134. Slew Rate Control 1 Register

7	6	5	4	3	2	1	0
HB8_SR	HB7_SR	HB6_SR	HB5_SR	HB4_SR	HB3_SR	HB2_SR	HB1_SR
R/W-0b	R/W-0b	R/W-0b	R/W-0b	R/W-0b	R/W-0b	R/W-0b	R/W-0b

Table 84. Slew Rate Control 1 Register Field Descriptions

Bit	Field	Type	Default	Description
7	HB8_SR	R/W	0b	0b = 0.6 V/μs 1b = 2.5 V/μs
6	HB7_SR	R/W	0b	0b = 0.6 V/μs 1b = 2.5 V/μs
5	HB6_SR	R/W	0b	0b = 0.6 V/μs 1b = 2.5 V/μs
4	HB5_SR	R/W	0b	0b = 0.6 V/μs 1b = 2.5 V/μs
3	HB4_SR	R/W	0b	0b = 0.6 V/μs 1b = 2.5 V/μs
2	HB3_SR	R/W	0b	0b = 0.6 V/μs 1b = 2.5 V/μs
1	HB2_SR	R/W	0b	0b = 0.6 V/μs 1b = 2.5 V/μs
0	HB1_SR	R/W	0b	0b = 0.6 V/μs 1b = 2.5 V/μs

8.6.2.2.24 Slew Rate Control 2 (SR_CTRL_2) Register (Address = 0x1E) [reset = 0x00]

The slew rate control 2 register is shown in [Figure 135](#) and described in [Table 85](#).

Register access type: Read/Write

Figure 135. Slew Rate Control 2 Register

7	6	5	4	3	2	1	0
Reserved							
R/W-0b	R/W-0b	R/W-0b	R/W-0b	R/W-0b	R/W-0b	R/W-0b	R/W-0b

Table 85. Slew Rate Control 2 Register Field Descriptions

Bit	Field	Type	Default	Description
7-4	Reserved	R/W	0000b	Reserved

8.6.2.2.25 Open-Load Detect (OLD) Control 1 (OLD_CTRL_1) Register (Address = 0x1F) [reset = 0x00]

The open-load detect (OLD) control (OLD_CTRL_1) register-1 is shown in [Figure 136](#) and described in [Table 86](#).

Register access type: Read/Write

Figure 136. Open-Load Detect (OLD) Control (OLD_CTRL_1) Register

7	6	5	4	3	2	1	0
HB8_OLD_DIS	HB7_OLD_DIS	HB6_OLD_DIS	HB5_OLD_DIS	HB4_OLD_DIS	HB3_OLD_DIS	HB2_OLD_DIS	HB1_OLD_DIS
R/W-0b	R/W-0b	R/W-0b	R/W-0b	R/W-0b	R/W-0b	R/W-0b	R/W-0b

Table 86. Open-Load Detect (OLD) Control (OLD_CTRL_1) Register Field Descriptions

Bit	Field	Type	Default	Description
7	HB8_OLD_DIS	R/W	0b	0b = Open-load detection on half-bridge 8 is enabled 1b = Open-load on half-bridge 8 is disabled
6	HB7_OLD_DIS	R/W	0b	0b = Open-load detection on half-bridge 7 is enabled 1b = Open-load on half-bridge 7 is disabled
5	HB6_OLD_DIS	R/W	0b	0b = Open-load detection on half-bridge 6 is enabled 1b = Open-load on half-bridge 6 is disabled
4	HB5_OLD_DIS	R/W	0b	0b = Open-load detection on half-bridge 5 is enabled 1b = Open-load on half-bridge 5 is disabled
3	HB4_OLD_DIS	R/W	0b	0b = Open-load detection on half-bridge 4 is enabled 1b = Open-load on half-bridge 4 is disabled
2	HB3_OLD_DIS	R/W	0b	0b = Open-load detection on half-bridge 3 is enabled 1b = Open-load on half-bridge 3 is disabled
1	HB2_OLD_DIS	R/W	0b	0b = Open-load detection on half-bridge 2 is enabled 1b = Open-load on half-bridge 2 is disabled
0	HB1_OLD_DIS	R/W	0b	0b = Open-load detection on half-bridge 1 is enabled 1b = Open-load on half-bridge 1 is disabled

8.6.2.2.26 Open-Load Detect (OLD) Control 2 (OLD_CTRL_2) Register (Address = 0x20) [reset = 0x00]

The open-load detect (OLD) control (OLD_CTRL_2) register-2 is shown in [Figure 137](#) and described in [Table 87](#).

Register access type: Read/Write

Figure 137. Open-Load Detect (OLD) Control (OLD_CTRL_2) Register

7	6	5	4	3	2	1	0
OLD_REP	OLD_OP	PL_MODE_EN		Reserved			
R/W-0b	R/W-0b	R/W-0b	R/W-0b	R/W-0b	R/W-0b	R/W-0b	R/W-0b

Table 87. Open-Load Detect (OLD) Control (OLD_CTRL_2) Register Field Descriptions

Bit	Field	Type	Default	Description
7	OLD_REP	R/W	0b	0b = Report on nFAULT pin during OLD condition 1b = No report on nFAULT pin during OLD condition
6	OLD_OP	R/W	0b	0b = Half bridges are not active after OLD condition detect 1b = Half bridges are active after OLD condition detect
5-4	PL_MODE_EN	R/W	00b	00b = Parallel mode OCP fast turn-off slew is enabled 01b = Parallel mode OCP slow turn-off slew is enabled 10b = Invalid Setting 11b = Invalid Setting
3-0	Reserved	R	0b	Reserved

8.6.2.2.27 Open-Load Detect (OLD) Control 3 (OLD_CTRL_3) Register (Address = 0x21) [reset = 0x00]

The open-load detect (OLD) control (OLD_CTRL_3) register-3 is shown in [Figure 138](#) and described in [Table 88](#). This register also contains the bits to set the OCP deglitch time (OCP_DEG).

Register access type: Read/Write

Figure 138. Open-Load Detect (OLD) Control (OLD_CTRL_3) Register

7	6	5	4	3	2	1	0
OCP_DEG		OLD_NEG_EN		Reserved			
R/W-0b	R/W-0b	R/W-0b	R/W-0b	R/W-0b	R/W-0b	R/W-0b	R/W-0b

Table 88. Open-Load Detect (OLD) Control (OLD_CTRL_3) Register Field Descriptions

Bit	Field	Type	Default	Description
7-5	OCP_DEG	R/W	000b	000b = OCP deglitch time is 10 μs 001b = OCP deglitch time is 5 μ s 010b = OCP deglitch time is 2.5 μ s 011b = OCP deglitch time is 1 μ s 100b = OCP deglitch time is 60 μ s 101b = OCP deglitch time is 40 μ s 110b = OCP deglitch time is 30 μ s 111b = OCP deglitch time is 20 μ s
4	OLD_NEG_EN	R/W	0b	0b = Negative-current OLD mode is disabled 1b = Negative-current OLD mode is enabled
3-0	Reserved	R/W	0b	Reserved

8.6.2.2.28 Open Load Detect (OLD) Control 4 (OLD_CTRL_4) Register (Address = 0x22) [reset = 0x00]

The open load detect (OLD) control (OLD_CTRL_4) register-4 is shown in [Figure 139](#) and described in [Table 89](#).

Register access type: Read/Write

Figure 139. Open Load Detect (OLD) Control (OLD_CTRL_4) Register

7	6	5	4	3	2	1	0
HB8_LCOLD_EN	HB7_LOLD_EN	HB6_LOLD_EN	HB5_LOLD_EN	HB4_LOLD_EN	HB3_LOLD_EN	HB2_LOLD_EN	HB1_LOLD_EN
R/W-0b	R/W-0b	R/W-0b	R/W-0b	R/W-0b	R/W-0b	R/W-0b	R/W-0b

Table 89. Open Load Detect (OLD) Control (OLD_CTRL_4) Register Field Descriptions

Bit	Field	Type	Default	Description
7	HB8_LOLD_EN	R/W	0b	0b = Low-current OLD on half-bridge 8 is disabled 1b = Low-current OLD on half-bridge 8 is enabled
6	HB7_LOLD_EN	R/W	0b	0b = Low-current OLD on half-bridge 7 is disabled 1b = Low-current OLD on half-bridge 7 is enabled
5	HB6_LOLD_EN	R/W	0b	0b = Low-current OLD on half-bridge 6 is disabled 1b = Low-current OLD on half-bridge 6 is enabled
4	HB5_LOLD_EN	R/W	0b	0b = Low-current OLD on half-bridge 5 is disabled 1b = Low-current OLD on half-bridge 5 is enabled
3	HB4_LOLD_EN	R/W	0b	0b = Low-current OLD on half-bridge 4 is disabled 1b = Low-current OLD on half-bridge 4 is enabled
2	HB3_LOLD_EN	R/W	0b	0b = Low-current OLD on half-bridge 3 is disabled 1b = Low-current OLD on half-bridge 3 is enabled
1	HB2_LOLD_EN	R/W	0b	0b = Low-current OLD on half-bridge 2 is disabled 1b = Low-current OLD on half-bridge 2 is enabled
0	HB1_LOLD_EN	R/W	0b	0b = Low-current OLD on half-bridge 1 is disabled 1b = Low-current OLD on half-bridge 1 is enabled

8.6.2.2.29 Open Load Detect (OLD) Control 5 (OLD_CTRL_5) Register (Address = 0x23) [reset = 0x00]

 The open load detect (OLD) (OLD_CTRL_5) register-5 is shown in [Figure 140](#) and described in [Table 90](#).

Figure 140. Open Load Detect (OLD) Control (OLD_CTRL_5) Register

7	6	5	4	3	2	1	0
HB8_POLD_E N	HB7_POLD_E N	HB6_POLD_E N	HB5_POLD_E N	HB4_POLD_E N	HB3_POLD_E N	HB2_POLD_E N	HB1_POLD_E N
R/W-0b	R/W-0b	R/W-0b	R/W-0b	R/W-0b	R/W-0b	R/W-0b	R/W-0b

Table 90. Open Load Detect (OLD) Control (OLD_CTRL_5) Register Field Descriptions

Bit	Field	Type	Default	Description
7	HB8_POLD_EN	R/W	0b	0b = Passive OLD operation of half-bridge 8 is disabled 1b = Passive OLD operation of half-bridge 8 is enabled
6	HB7_POLD_EN	R/W	0b	0b = Passive OLD operation of half-bridge 7 is disabled 1b = Passive OLD operation of half-bridge 7 is enabled
5	HB6_POLD_EN	R/W	0b	0b = Passive OLD operation of half-bridge 6 is disabled 1b = Passive OLD operation of half-bridge 6 is enabled
4	HB5_POLD_EN	R/W	0b	0b = Passive OLD operation of half-bridge 5 is disabled 1b = Passive OLD operation of half-bridge 5 is enabled
3	HB4_POLD_EN	R/W	0b	0b = Passive OLD operation of half-bridge 4 is disabled 1b = Passive OLD operation of half-bridge 4 is enabled
2	HB3_POLD_EN	R/W	0b	0b = Passive OLD operation of half-bridge 3 is disabled 1b = Passive OLD operation of half-bridge 3 is enabled
1	HB2_POLD_EN	R/W	0b	0b = Passive OLD operation of half-bridge 2 is disabled 1b = Passive OLD operation of half-bridge 2 is enabled
0	HB1_POLD_EN	R/W	0b	0b = Passive OLD operation of half-bridge 1 is disabled 1b = Passive OLD operation of half-bridge 1 is enabled

8.6.2.2.30 Open Load Detect (OLD) Control 6 (OLD_CTRL_6) Register (Address = 0x24) [reset = 0x00]

The open load detect (OLD) (OLD_CTRL_6) register-6 register is shown in [Figure 141](#) and described in [Table 91](#).

Figure 141. Open Load Detect (OLD) Control (OLD_CTRL_6) Register

7	6	5	4	3	2	1	0
HB8_VM_POL D	HB7_VM_POL D	HB6_VM_POL D	HB5_VM_POL D	HB4_VM_POL D	HB3_VM_POL D	HB2_VM_POL D	HB1_VM_POL D
R/W-0b	R/W-0b	R/W-0b	R/W-0b	R/W-0b	R/W-0b	R/W-0b	R/W-0b

Table 91. Open Load Detect (OLD) Control (OLD_CTRL_6) Register Field Descriptions

Bit	Field	Type	Default	Description
7	HB8_VM_POLD	R/W	0b	0b = Passive OLD operation for VM connected load of half-bridge 8 is disabled 1b = Passive OLD operation for VM connected load of half-bridge 8 is enabled
6	HB7_VM_POLD	R/W	0b	0b = Passive OLD operation for VM connected load of half-bridge 7 is disabled 1b = Passive OLD operation for VM connected load of half-bridge 7 is enabled
5	HB6_VM_POLD	R/W	0b	0b = Passive OLD operation for VM connected load of half-bridge 6 is disabled 1b = Passive OLD operation for VM connected load of half-bridge 6 is enabled
4	HB5_VM_POLD	R/W	0b	0b = Passive OLD operation for VM connected load of half-bridge 5 is disabled 1b = Passive OLD operation for VM connected load of half-bridge 5 is enabled
3	HB4_VM_POLD	R/W	0b	0b = Passive OLD operation for VM connected load of half-bridge 4 is disabled 1b = Passive OLD operation for VM connected load of half-bridge 4 is enabled
2	HB3_VM_POLD	R/W	0b	0b = Passive OLD operation for VM connected load of half-bridge 3 is disabled 1b = Passive OLD operation for VM connected load of half-bridge 3 is enabled
1	HB2_VM_POLD	R/W	0b	0b = Passive OLD operation for VM connected load of half-bridge 2 is disabled 1b = Passive OLD operation for VM connected load of half-bridge 2 is enabled
0	HB1_VM_POLD	R/W	0b	0b = Passive OLD operation for VM connected load of half-bridge 1 is disabled 1b = Passive OLD operation for VM connected load of half-bridge 1 is enabled

9 Application and Implementation

NOTE

Information in the following applications sections is not part of the TI component specification, and TI does not warrant its accuracy or completeness. TI's customers are responsible for determining suitability of components for their purposes. Customers should validate and test their design implementation to confirm system functionality.

9.1 Application Information

The DRV89xx-Q1 device is primarily used in control of multiple brushed DC motors in HVAC applications. The design procedures in the [Typical Application](#) section highlight how to use and configure the DRV89xx-Q1 device.

The DRV89xx-Q1 device can alternatively be used in automotive side-mirrors targeting the mirror-fold (by paralleling the half-bridges to meet the high current requirement), mirror x-y direction control and side indicator LED's as presented in [Alternative Application](#) section.

9.2 Typical Application

9.2.1 Primary Application

The DRV89xx-Q1 is primarily used for the control of multiple brushed DC motors which can be connected in independent-type, sequential-type or the parallel-type motor connection as shown in Figure 142.

An automotive battery powers the device to power supply pin (VM). A 3.3-V regulated power supply is generated for the supplying power to the digital core (VDD) of the device. A micro-controller is connected to the DRV89XX-Q1 device with the SPI interface (4-lines) for control, configuration and diagnostics. The device operating or sleep state is controlled by the nSLEEP pin and nFAULT pin is used as an additional hardware diagnostics.

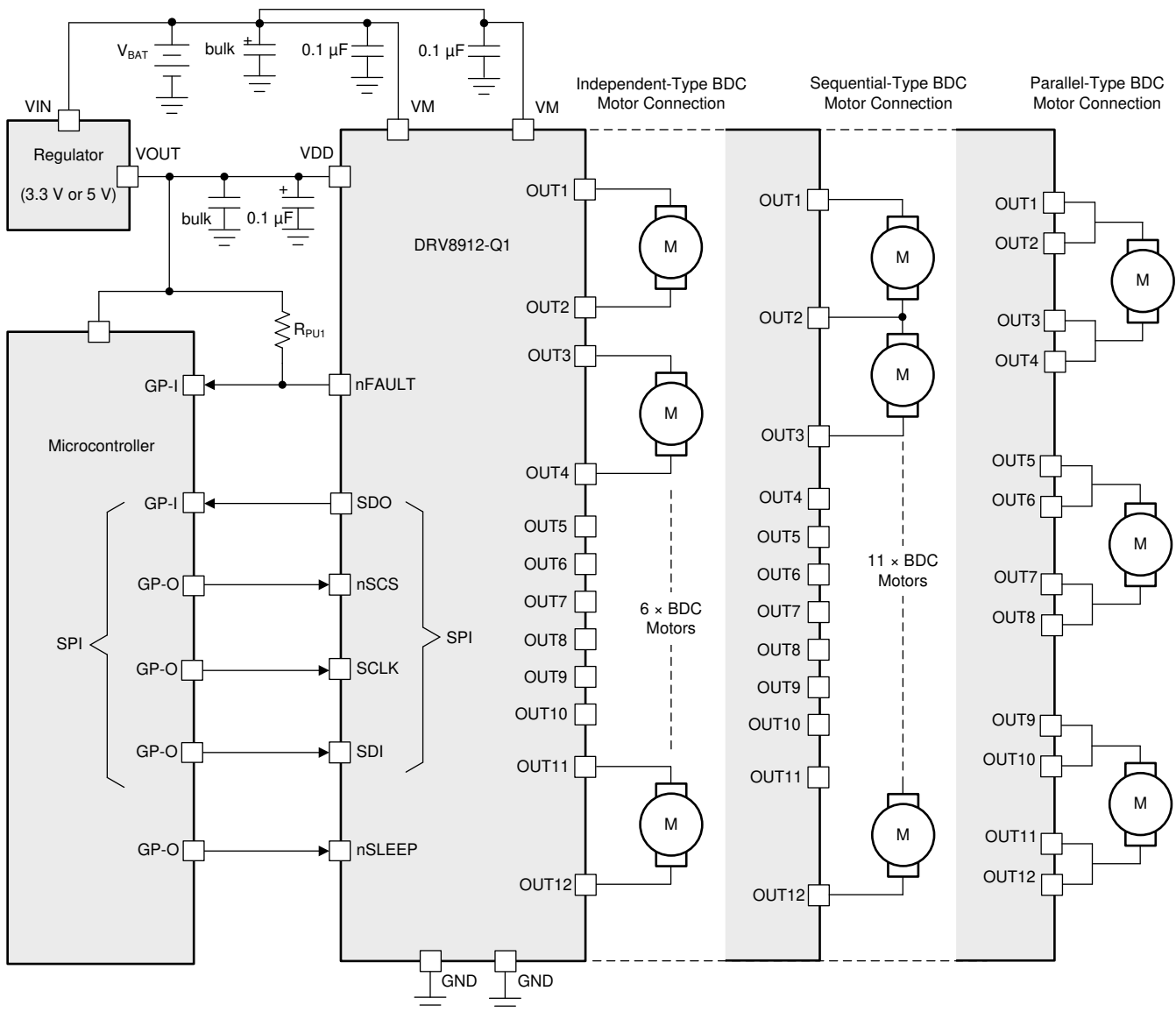

Figure 142. Primary Application Schematic (Automotive HVAC Application)

Typical Application (continued)

9.2.1.1 Design Requirements

Table 92 lists example input parameters for the system design.

Table 92. Design Parameters

DESIGN PARAMETERS	REFERENCE	EXAMPLE VALUE
Supply voltage	V_{VM}	13.5-V
Supply digital voltage	V_{VDD}	3.3-V
Number of motor connected	N	6 motors
Number of motor operating in normal operation	N_F	4 motors
Number of motor operating in stall condition	N_S	2 motors
Motor RMS current	I_{RMS}	200-mA
Motor peak current	I_{PEAK}	800-mA
Motor resistance	R_{MOTOR}	16.9- Ω
Motor inductance	L_{MOTOR}	10-mH
PWM Frequency	f_{PWM}	2-kHz (Internal)
Rise and fall time for continuous mode (SR = 0)	t_{RISE_CONT} , t_{FALL_CONT}	22.5- μ s
Rise and fall time for PWM mode (SR = 1)	t_{RISE_PWM} , t_{FALL_PWM}	5.4- μ s

9.2.1.2 Detailed Design Procedure

The design procedure includes the selection of motor current rating the power dissipation to meet the desired thermal performance.

9.2.1.2.1 Motor Current Rating

Motor specification selection is the most importance criteria for the design. Each half-bridge (OUTx) of the DRV89XX-Q1 device is designed to handle RMS current of 1 A and the peak current is limited by the minimum over-current (OCP) limit of 1.3-A. Therefore, a motor with peak starting current higher than 1.3-A is expected to hit OCP limit. For higher peak current motors (starting current higher than 1.3-A), following methods can be implemented:

- Current Chopping:** During starting, if supply voltage is connected directly to the motor, then due to low back-emf (when speed is zero or low), a huge peak current is demanded by the motor. This peak current is only limited by the motor's winding resistance (R_{MOTOR}). This peak current of motor can be limited by starting the motor with low-duty PWM switching operation and then gradually increasing (duty-ramping) the duty with speed to 100% PWM operation (equivalent to motor operating in continuous mode). This duty-ramping provides enough time to ramp motor speed and build sufficient back-emf which limits the peak current. The DRV89XX-Q1 device implements a 2-kHz PWM switching operation which is suitable for the HVAC damper motors.
- OCP Deglitch Time Adjustments:** This method is applicable if the motor inertia is low and the motor can quickly pick up the speed. For this method, the motor starting current should settle to lower than minimum over-current limit (I_{OCP}) before OCP deglitch time (t_{OCP}) is over. The device provides multiple (8 settings) OCP deglitch time settings with a default deglitch time of 10- μ s and can be increased to a maximum value of 60- μ s.

NOTE

For multiple motor connection, it has to be ensured that the total device current should be lower than the maximum current-carrying capability of the power-supply (VM/GND) pins i.e. 6-A (maximum).

9.2.1.2.2 Power Dissipation

A detailed explanation of the power dissipation of the device is presented in [Power Dissipation](#) section.

9.2.2 Alternative Application

The DRV89xx-Q1 can alternatively be used for the mirrors targeting the mirror-fold, mirror x-y direction control and side indicator LED's as shown in Figure 143.

The half-bridges are connected in parallel to support the higher current requirement of the mirror fold application. Whereas, single half-bridges can be used for driving the low-current motors used for the mirror X and Y positioning. Moreover, the LED's used in side indicators, puddle lamp is lower current which can be easily driven by single half-bridges.

The driver is powered by the automotive battery with a 3.3-V regulated power supply generated for the supplying power to the digital pin (VDD). A micro-controller is connected to the DRV89XX-Q1 device with the SPI interface (4-lines) for control, configuration and diagnostics. The device operating or sleep state is controlled by the nSLEEP pin and nFAULT pins is used as an additional hardware diagnostics.

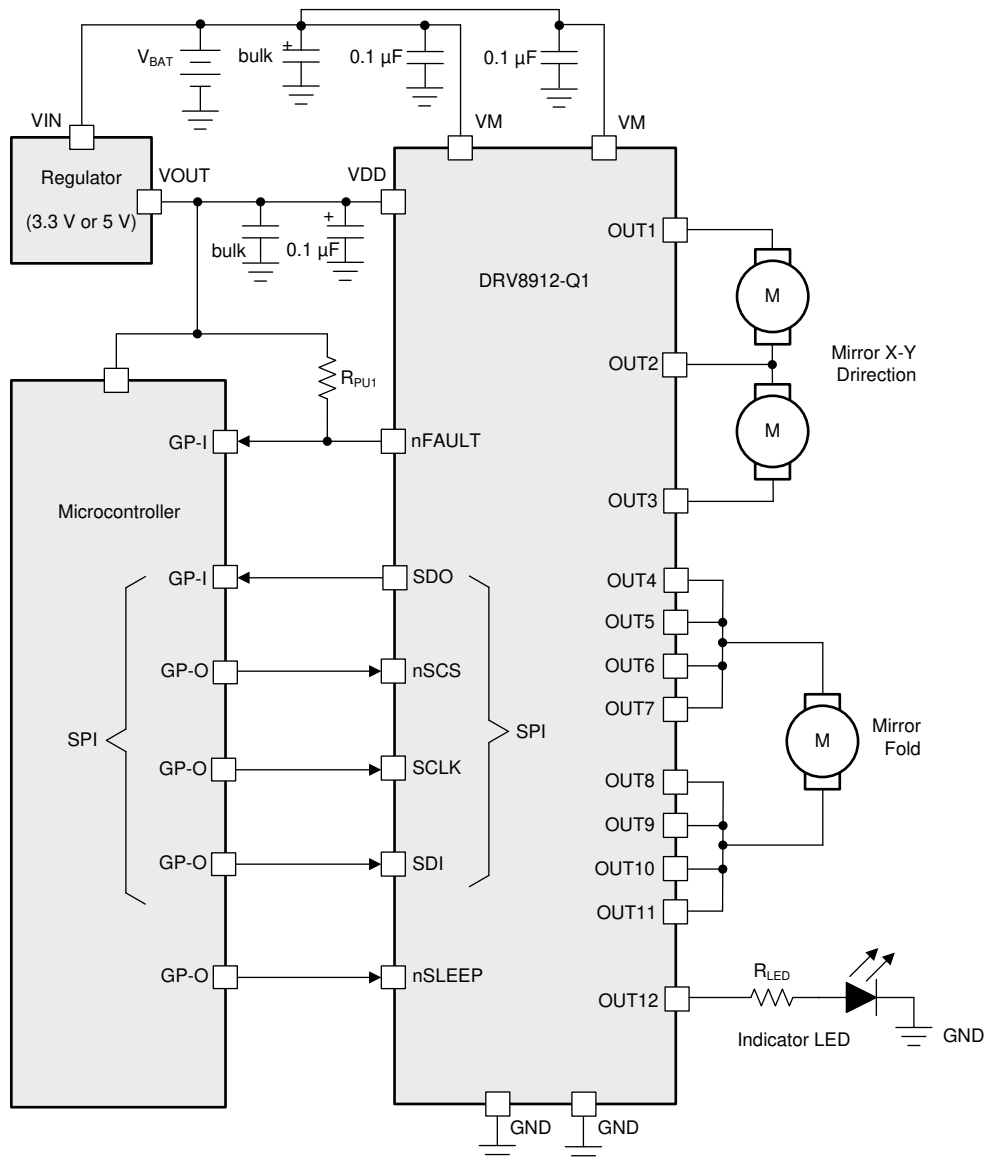

Figure 143. Alternative Application Schematic (Automotive Side-Mirror Application)

9.2.2.1 Design Requirements

Table 93 lists example input parameters for the system design.

Table 93. Design Parameters

DESIGN PARAMETERS	REFERENCE	EXAMPLE VALUE
Supply voltage	V_{VM}	13.5-V
Supply digital voltage	V_{VDD}	3.3-V
Motor RMS current (Mirror Fold Motor)	I_{RMS_FOLD}	1.8-A
Motor peak current (Mirror Fold Motor)	I_{PEAK_FOLD}	3-A
Motor RMS current (X/Y Direction Motor)	I_{RMS_XY}	200-mA
Motor peak current (X/Y Direction Motor)	I_{PEAK_XY}	800-mA
LED Current	I_{LED}	150-mA
PWM Frequency (Motor)	f_{PWM_MOTOR}	2-kHz (Internal)
PWM Frequency (LED)	f_{PWM_LED}	100-Hz (Internal)
Rise and fall time for continuous mode (SR = 0)	$t_{RISE_CONT}, t_{FALL_CONT}$	22.5- μ s
Rise and fall time for PWM mode (SR = 1)	$t_{RISE_PWM}, t_{FALL_PWM}$	5.4- μ s

9.2.2.2 Detailed Design Procedure

The key-requirement for this application is the selection of number of half-bridges to operate in parallel for the high current motor (mirror-fold) application. [Parallel Mode \(Continuous Operation\)](#) describes the configuration for half-bridges for enabling the parallel mode operation.

9.2.2.2.1 H-Bridge Requirements for Parallel Operation

The selection of number of half-bridges for connecting in parallel operation to support higher current depends on two parameters as:

- Peak / Stall Current:** The mirror-fold motor peak current decides the amount of current flowing through a single half-bridge which has to be lower than the minimum OCP (I_{OCP}) threshold limit. A current limiting approach for limiting the peak current of motor can also be implemented as shown in [Motor Current Rating](#) section. This section also explains the application of adjusting the OCP deglitch timing for meeting the desired peak currents.
- Thermal:** For meeting the desired thermal performance during the peak current / stall condition, the number of half-bridges is increased to reduce the effective $R_{DS(ON)}$.

For this example as shown in [Table 93](#), six half-bridges can be connected in parallel combination (3 half-bridges for high-side and 3 half-bridges for low-side) to support the 3-A peak current requirement. The power dissipation for this can be calculated in similar way as explained in [Thermal Application](#) section.

9.2.3 Application Curves

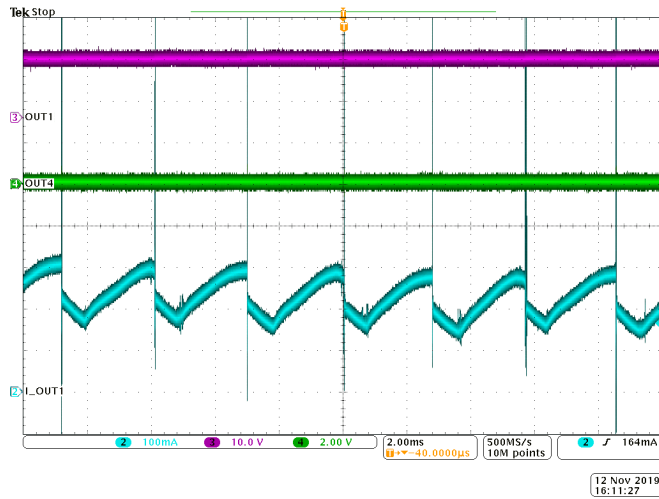

12 Nov 2019
 16:11:27

Figure 144. Motor Operation in Continuous Mode

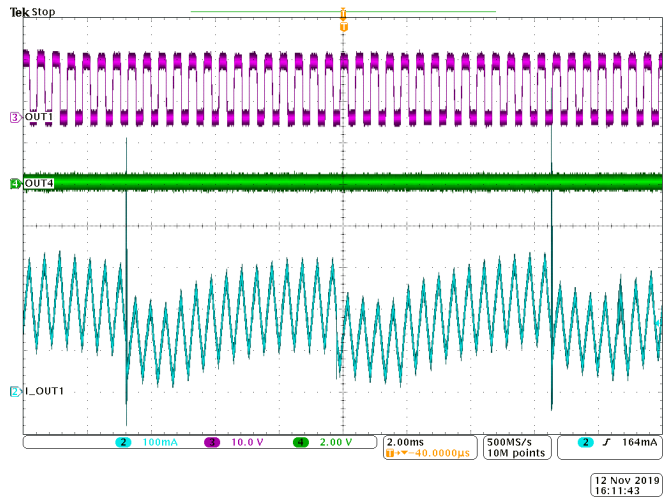

12 Nov 2019
 16:11:43

Figure 145. Motor Operation in PWM Mode

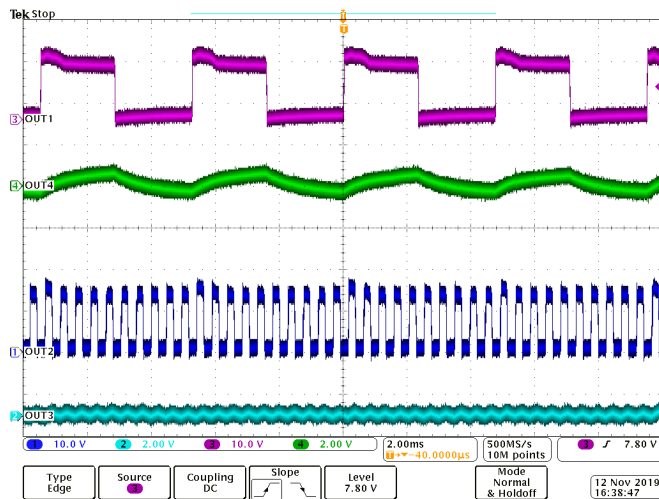

12 Nov 2019
 16:38:47

Figure 146. Multiple Motor Operation in PWM Mode

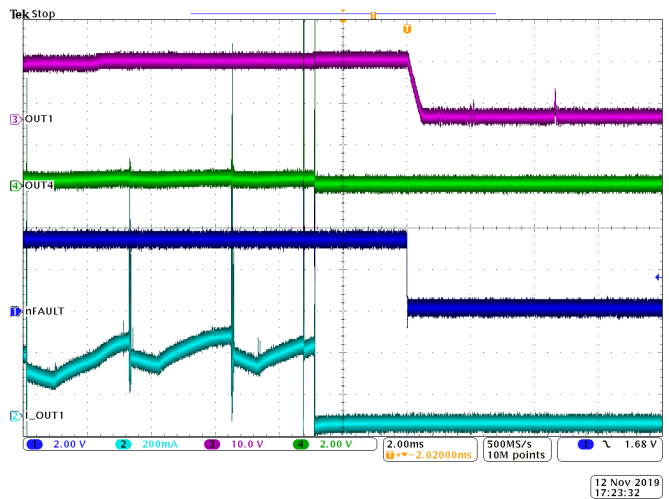

12 Nov 2019
 17:23:32

Figure 147. Active Open-Load Detection

9.3 Thermal Application

This section presents the power dissipation and thermal analysis of DRV89XX-Q1 device applicable for different types of PCB's.

9.3.1 Power Dissipation

The total power dissipation in the DRV89XX-Q1 device constitutes three main components as the power dissipation in full-bridges (P_{DRV}) due to on-state resistance ($R_{DS(ON)}$), power dissipation due to switching losses in FETs (P_{SW}) and power losses due to quiescent current consumption (P_Q).

9.3.1.1 Power Dissipation Due to Device On-State Resistance ($R_{DS(ON)}$)

The current path for a motor connected in full-bridge is through the high-side FET of one half-bridge and low-side FET of other half-bridge. The power dissipation of DRV89XX-Q1 depends on the amount of current flowing through the full-bridge and the number of such full-bridges which are operating together. The power dissipation (P_{FB_CONT}) in a single full-bridge configuration for continuous mode depends on the motor rms current (I_{RMS}) and high-side ($R_{DS(ON)_HS}$) and low-side ($R_{DS(ON)_LS}$) on-state resistance as shown in [Equation 1](#).

$$P_{FB_CONT} = (I_{RMS})^2 \times (R_{DS(ON)_HS} + R_{DS(ON)_LS}) \quad (1)$$

The power dissipation (P_{FB_STALL}) in a single full-bridge configuration for motor is a stall condition depends on the motor peak current (I_{PEAK}) and high-side ($R_{DS(ON)_HS}$) and low-side ($R_{DS(ON)_LS}$) on-state resistance as shown in [Equation 2](#).

$$P_{FB_STALL} = (I_{PEAK})^2 \times (R_{DS(ON)_HS} + R_{DS(ON)_LS}) \quad (2)$$

Now, the power dissipation for operating mode and stall mode in single full-bridge for the typical application as shown in [Table 92](#) is calculated in [Equation 3](#) and [Equation 4](#) respectively.

$$P_{FB_CONT} = (I_{RMS})^2 \times (R_{DS(ON)_HS} + R_{DS(ON)_LS}) = (200\text{-mA})^2 \times (0.75\text{-}\Omega + 0.75\text{-}\Omega) = 60\text{-mW} \quad (3)$$

$$P_{FB_STALL} = (I_{PEAK})^2 \times (R_{DS(ON)_HS} + R_{DS(ON)_LS}) = (800\text{-mA})^2 \times (0.75\text{-}\Omega + 0.75\text{-}\Omega) = 960\text{-mW} \quad (4)$$

For N_F -full bridges in operating condition and N_S -full bridges in stall condition, the total driver power (P_{DRV}) is expressed and calculated as shown in [Equation 5](#).

$$P_{DRV} = N_F \times P_{FB_CONT} + N_S \times P_{FB_STALL} = 4 \times 60\text{-mW} + 2 \times 960\text{-mW} = 2.16\text{-W} \quad (5)$$

NOTE

This power calculation is highly dependent on the device temperature which significantly effects the high-side and low-side $R_{DS(ON)}$ of the FETs. For more accurate calculation, consider the dependency of $R_{DS(ON)}$ of FETs with device temperature.

9.3.1.2 Power Dissipation Due to Switching Losses

The power loss due to the PWM switching frequency depends on the slew rates (rise-time, t_{RISE_PWM} , and fall-time, t_{FALL_PWM}), supply voltage (V_{VM}), motor RMS current (I_{RMS}) and the PWM switching frequency (f_{PWM}). Considering a case, where the PWM switching is only applicable for single half-bridge in a full-bridge configuration (see [Free-Wheeling Mode \(Synchronous Rectification\) Disable / Enable](#)), therefore only half of the half-bridges are operating in PWM switching. Hence, the switching losses during rise-time and fall-time is calculated as shown in [Equation 6](#) and [Equation 7](#).

$$P_{SW_RISE} = (N_F/2) \times 0.5 \times V_{VM} \times I_{RMS} \times t_{RISE_PWM} \times f_{PWM} \quad (6)$$

$$P_{SW_FALL} = (N_F/2) \times 0.5 \times V_{VM} \times I_{RMS} \times t_{FALL_PWM} \times f_{PWM} \quad (7)$$

Putting various parameters from [Table 92](#) in [Equation 6](#) and [Equation 7](#), the rise-time (P_{SW_RISE}) and fall-time (P_{SW_FALL}) switching losses are calculated as shown in [Equation 8](#) and [Equation 9](#) as,

$$P_{SW_RISE} = (N_F/2) \times 0.5 \times V_{VM} \times I_{RMS} \times t_{RISE_PWM} \times f_{PWM} = (4/2) \times 0.5 \times 13.5\text{-V} \times 200\text{-mA} \times 9\text{-}\mu\text{s} \times 2\text{-kHz} = 48.6\text{-mW} \quad (8)$$

$$P_{SW_FALL} = (N_F/2) \times 0.5 \times V_{VM} \times I_{RMS} \times t_{FALL_PWM} \times f_{PWM} = (4/2) \times 0.5 \times 13.5\text{-V} \times 200\text{-mA} \times 9\text{-}\mu\text{s} \times 2\text{-kHz} = 48.6\text{-mW} \quad (9)$$

Hence, the total switching power (P_{SW}) is calculated as the sum of rise-time (P_{SW_RISE}) switching losses and fall-time (P_{SW_FALL}) switching losses as shown in [Equation 10](#).

$$P_{SW} = P_{SW_RISE} + P_{SW_FALL} = 48.6\text{-mW} + 48.6\text{-mW} = 97.2\text{-mW} \quad (10)$$

Thermal Application (continued)

NOTE

The rise-time (t_{RISE}) and the fall-time (t_{FALL}) are calculated based on typical values of the slew rate (SR) from [Specifications](#). This parameter is intended to change based on the supply-voltage, temperature and device to device variation.

9.3.1.3 Power Dissipation Due to Quiescent Current

The power dissipation due to the quiescent current taken by the power supply (P_{VM}) and the digital supply (P_{VDD}) depends on the applied voltage (V_{VM} and V_{VDD}) and operating mode currents (I_{VM} and I_{VDD}) and are calculated as shown in [Equation 11](#) and [Equation 12](#) respectively.

$$P_{VM} = V_{VM} \times I_{VM} \quad (11)$$

$$P_{VDD} = V_{VDD} \times I_{VDD} \quad (12)$$

Putting various parameters from [Table 92](#) in [Equation 11](#) and [Equation 12](#), the power-supply (P_{VM}) and digital-supply (P_{SW_FALL}) quiescent power losses are calculated as shown in [Equation 13](#) and [Equation 14](#) as,

$$P_{VM} = V_{VM} \times I_{VM} = 13.5\text{-V} \times 3\text{-mA} = 40.5\text{-mW} \quad (13)$$

$$P_{VDD} = V_{VDD} \times I_{VDD} = 3.3\text{-V} \times 3\text{-mA} = 9\text{-mW} \quad (14)$$

The total quiescent power loss (P_Q) is calculated as the sum of quiescent power loss due to VM and VDD as shown in [Equation 15](#) as,

$$P_Q = P_{VM} + P_{VDD} = 40.5\text{-mW} + 9.9\text{-mW} = 50.4\text{-mW} \quad (15)$$

NOTE

The quiescent power is calculated using the typical operating current (I_{VM} and I_{VDD}) which is dependent on supply-voltage, temperature and device to device variation.

9.3.1.4 Total Power Dissipation

The total power dissipation (P_{TOT}) is calculated as the sum of the power dissipation in full-bridges (P_{DRV}), power dissipation due to switching losses in FET's (P_{SW}) and power losses due to quiescent current consumption (P_Q) as shown in [Equation 16](#).

$$P_{TOT} = P_{DRV} + P_{SW} + P_Q \quad (16)$$

Now, by putting values of P_{DRV} , P_{SW} and P_Q from [Equation 5](#), [Equation 10](#) and [Equation 15](#) in [Equation 16](#), the total power dissipation (P_{TOT}) is calculated as shown in [Equation 17](#).

$$P_{TOT} = P_{DRV} + P_{SW} + P_Q = 2.16\text{-W} + 97.2\text{-mW} + 50.4\text{-mW} = 2.3076\text{-W} \quad (17)$$

9.3.2 PCB Types

Thermal analysis in this section is focused for the 2-layer and 4-layer PCB with two different copper thickness (1-oz and 2-oz) and six different copper areas (1-cm², 2-cm², 4-cm², 8-cm², 16-cm² and 32-cm²).

[Figure 148](#) and [Figure 149](#) shows the top-layer and bottom-layer which is applicable for both 2/4-layer PCB. [Figure 150](#) and [Figure 151](#) shows the mid-layer-1 and mid-layer-2 of a 4-layer PCB. The top-layer, mid-layer-1 and bottom-layer of the PCB is filled with ground plane, whereas, the mid-layer-2 is filled with power plane.

The thickness of copper for different PCB layers in different PCB types is summarized in [Table 94](#). The PCB dimension (A) for different PCB copper area is summarized in [Table 95](#).

Table 94. PCB Type and Copper Thickness

PCB Type	Copper Thickness	Top Layer	Bottom Layer	Mid-Layer 1	Mid-Layer 2
2-Layer	1-oz PCB	1-oz	1-oz	N/A	
	2-oz PCB	2-oz	2-oz		
4-Layer	1-oz PCB	1-oz	1-oz	1-oz	1-oz
	2-oz PCB	2-oz	2-oz	1-oz	1-oz

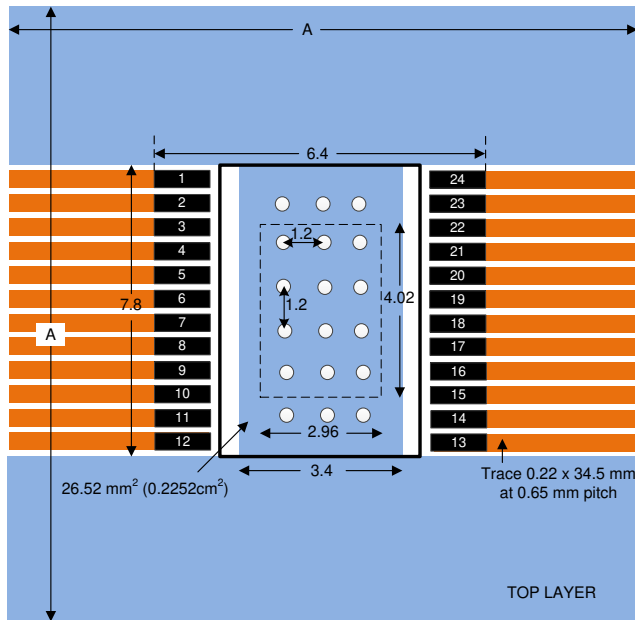

Figure 148. PCB - Top Layer (4/2-Layer PCB)

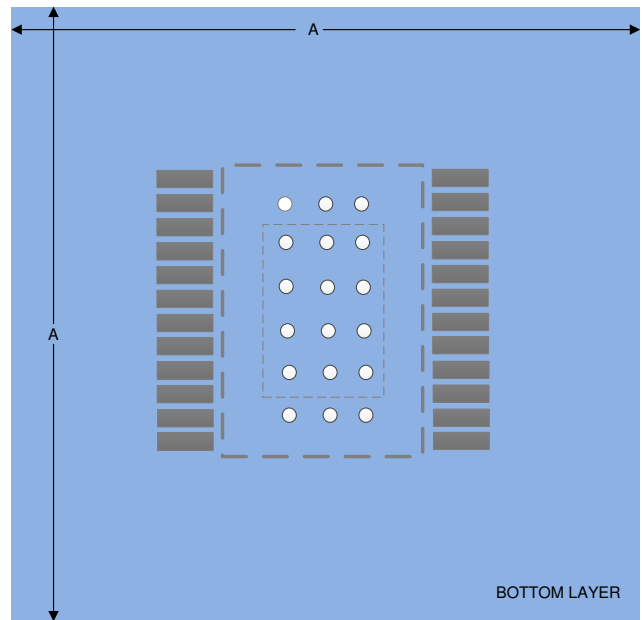

Figure 149. PCB - Bottom Layer (4/2-Layer PCB)

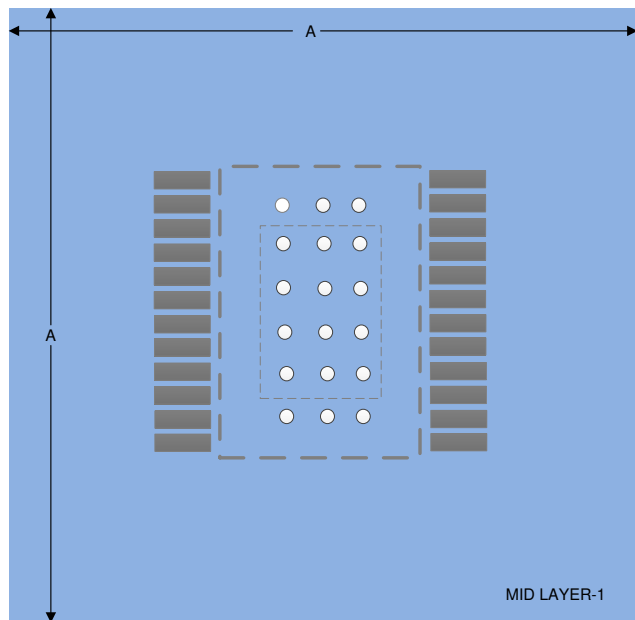

Figure 150. PCB - Mid Layer-1 (4-Layer PCB)

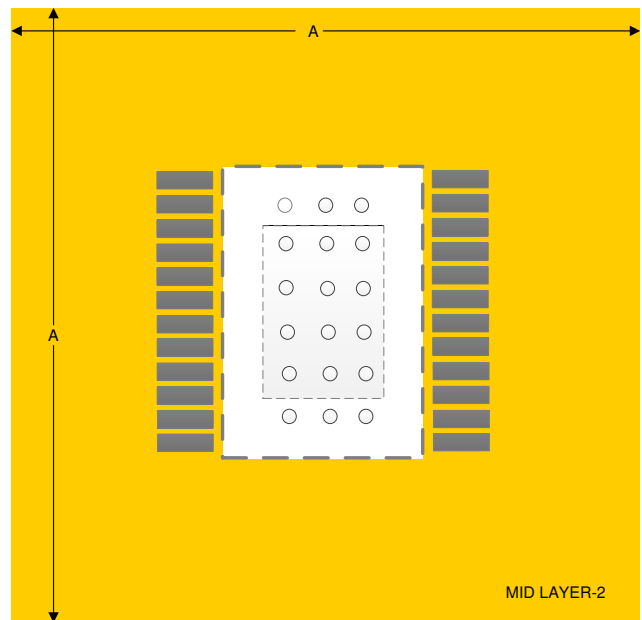

Figure 151. PCB - Mid Layer-2 (4-Layer PCB)

Table 95. PCB Dimension

COPPER AREA (cm ²)	DIMENSION (A) (mm)
1 cm ²	13.31 mm
2 cm ²	17.64 mm
4 cm ²	23.62 mm
8 cm ²	31.98 mm
16 cm ²	43.76 mm
32 cm ²	60.36 mm

9.3.3 Thermal Parameters

The variation of thermal parameters such as the $R_{\theta JA}$ (Junction-to-Ambient Thermal Resistance) and Ψ_{JB} (Junction-to-Board Characterization Parameter) is highly dependent on the PCB type, copper thickness and the copper pad area.

Figure 152 and Figure 153 shows the variation of the $R_{\theta JA}$ (Junction-to-Ambient Thermal Resistance) and Ψ_{JB} (Junction-to-Board Characterization Parameter) with copper-pad area for 2-layer PCB. As shown in these curves, the thermal resistance is lower for the higher copper thickness PCB and the higher copper pad-area.

Similarly, Figure 154 and Figure 155 shows the variation of the $R_{\theta JA}$ and Ψ_{JB} with copper-pad area for 4-layer PCB respectively.

NOTE

The thermal parameters ($R_{\theta JA}$ (Junction-to-Ambient Thermal Resistance) and Ψ_{JB} (Junction-to-Board Characterization Parameter)) are calculated considering the ambient temperature of 25°C and with 1.5-W power evenly dissipated between high-side and low-side FET's. The thermal parameters calculated considering the power dissipation at the actual location of the power-FETs rather than an averaged estimation.

The thermal parameters are highly dependent on the external conditions such as altitude, package geometry etc. Refer to [Application Report](#) for more details.

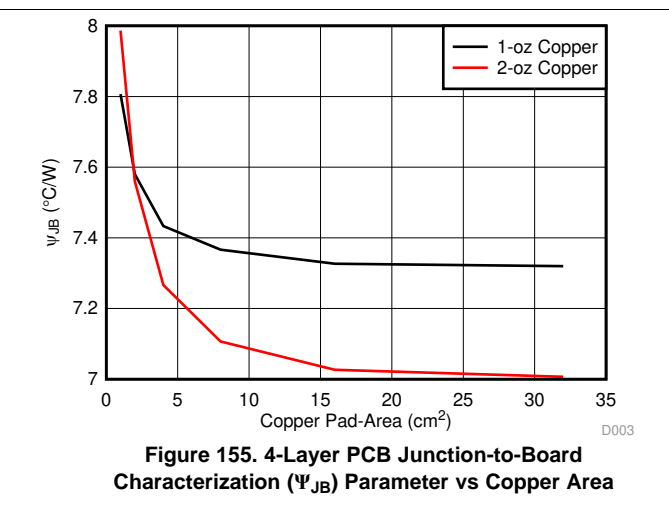
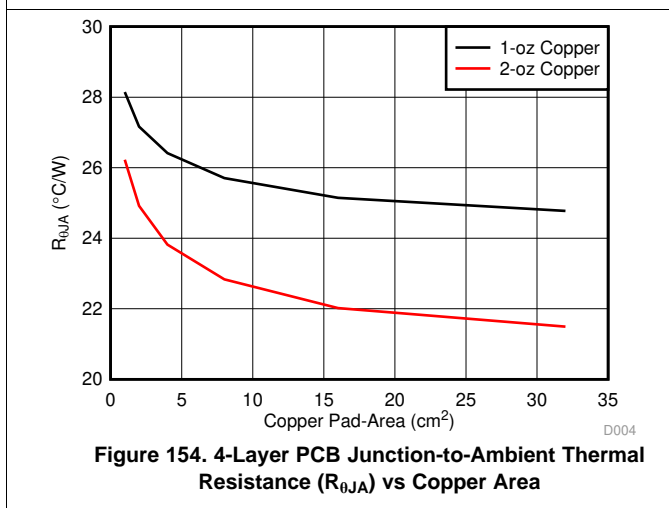
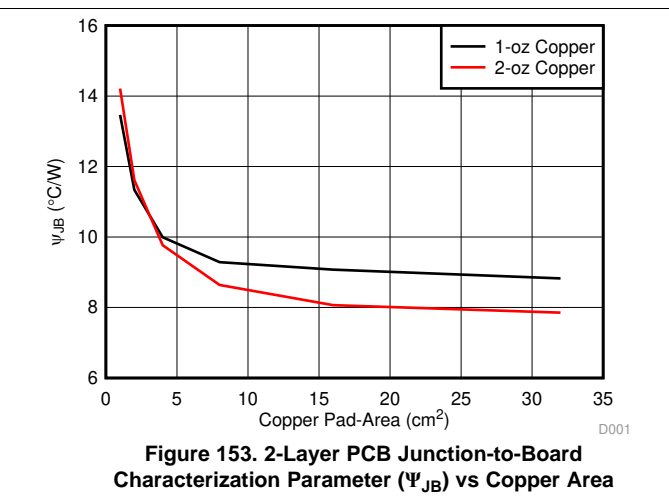
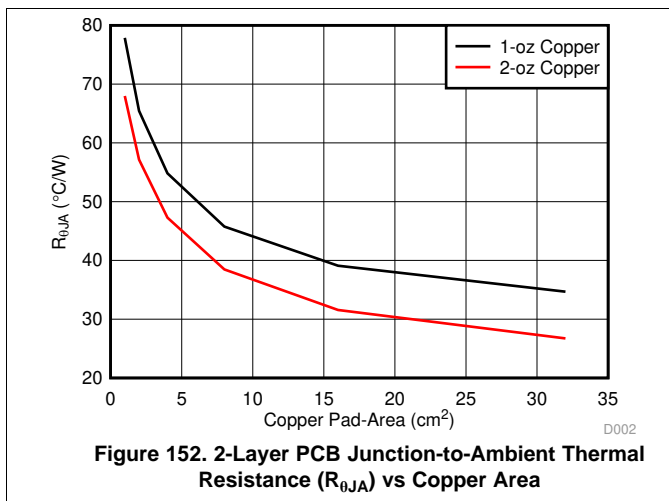

9.3.4 Transient Thermal

This section presents the variation of transient thermal parameters such as the $Z_{\theta JA}$ (Transient Junction-to-Ambient Thermal Resistance) and $Z_{\Psi JB}$ (Transient Junction-to-Board Characterization Parameter) with time for 4-layer PCB board with different copper pad area.

Figure 156, Figure 157 and Figure 158 shows the transient junction-to-ambient thermal resistance ($Z_{\theta JA}$) vs time for 4-Layer PCB with copper-pad area of 4-cm², 8-cm² and 16-cm² respectively.

Figure 159, Figure 160 and Figure 161 shows the transient junction-to-ambient thermal resistance ($Z_{\Psi JB}$) vs time for 4-Layer PCB with copper-pad area of 4-cm², 8-cm² and 16-cm² respectively.

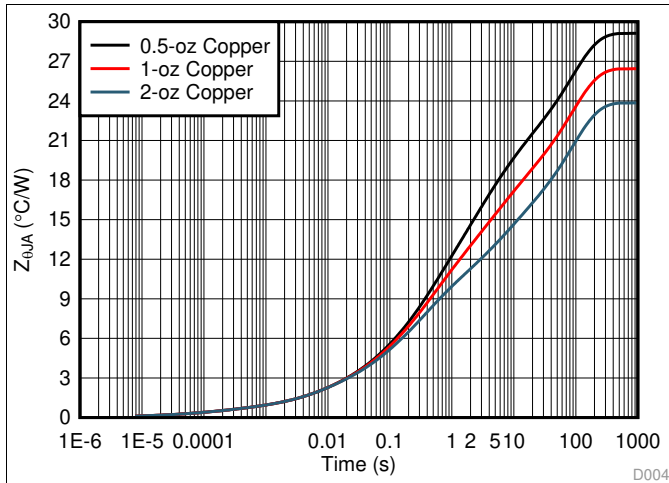

Figure 156. Transient Junction-to-Ambient Thermal Resistance ($Z_{\theta JA}$) vs Time for 4-Layer PCB with Copper-Pad Area of 4-cm²

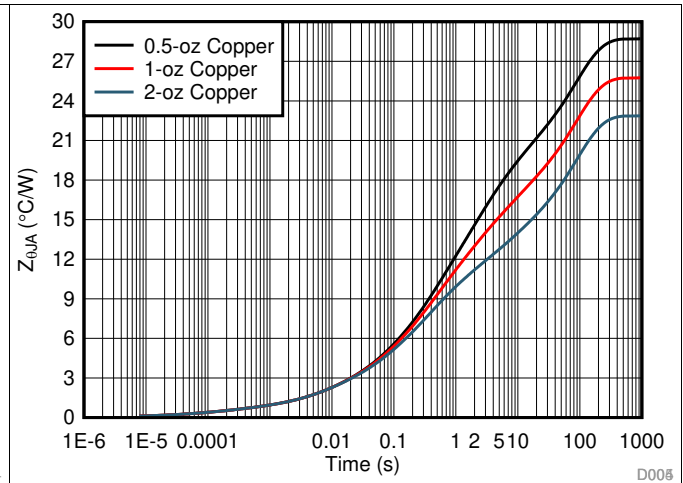

Figure 157. Transient Junction-to-Ambient Thermal Resistance ($Z_{\theta JA}$) vs Time for 4-Layer PCB with Copper-Pad Area of 8-cm²

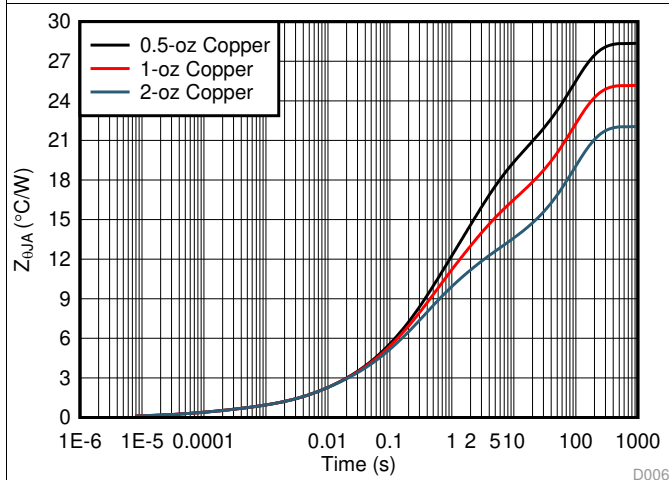

Figure 158. Transient Junction-to-Ambient Thermal Resistance ($Z_{\theta JA}$) vs Time for 4-Layer PCB with Copper-Pad Area of 16-cm²

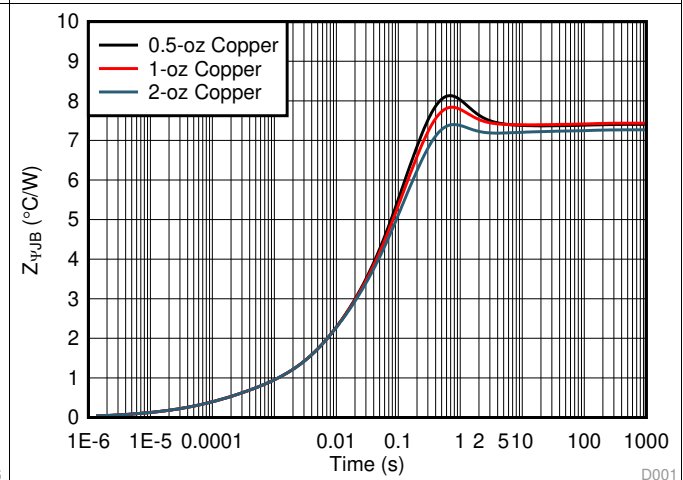
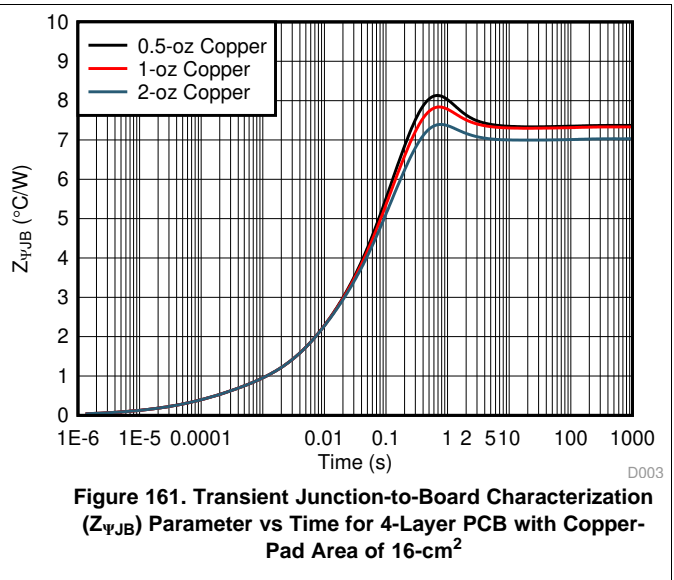
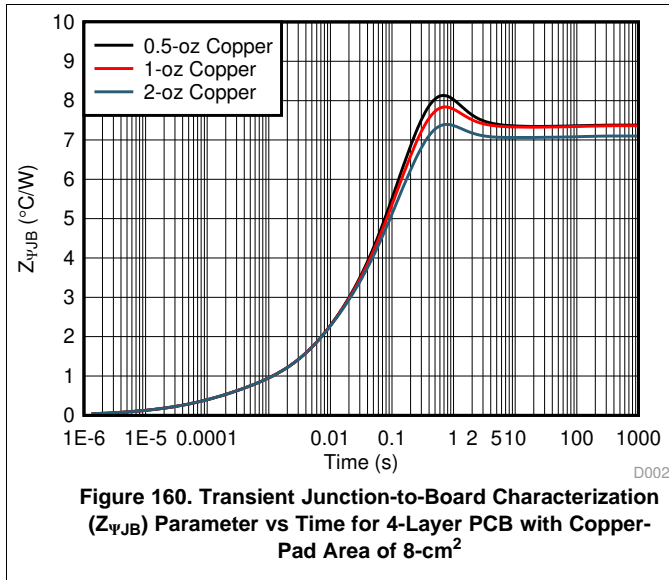

Figure 159. Transient Junction-to-Board Characterization ($Z_{\Psi JB}$) Parameter vs Time for 4-Layer PCB with Copper-Pad Area of 4-cm²



9.3.5 Device Junction Temperature Estimation

The device junction temperature (T_J) is calculated by the power dissipation and the thermal parameters (Junction-to-Ambient Thermal Resistance ($R_{\theta JA}$)) for the particular PCB. For an ambient temperature of T_A and total power dissipation (P_{TOT}), the junction temperature (T_J) is calculated as shown in Equation 18.

$$T_J = T_A + (P_{TOT} \times R_{\theta JA}) \quad (18)$$

Considering a 4-layer PCB, with copper thickness as 2-oz and copper-pad area as 16-cm², the junction-to-ambient thermal resistance ($R_{\theta JA}$) can be taken from Figure 154 as 22°C/W.

By putting the value of total power dissipation (P_{TOT}) from Equation 17 in Equation 18 and taking ambient temperature (T_A) as 25°C, the junction temperature is calculated as shown in Equation 19.

$$T_J = T_A + (P_{TOT} \times R_{\theta JA}) = 25^\circ\text{C} + (2.3076\text{-W} \times 22^\circ\text{C/W}) = 75.77^\circ\text{C} \quad (19)$$

Hence, the power dissipation of 2.3076-W in the DRV89XX-Q1 device causes the junction temperature (T_J) to increase to 75.77°C. This junction temperature has a margin of 74.23°C before hitting the thermal shutdown limit.

10 Power Supply Recommendations

The DRV89xx-Q1 device is designed to operate from an input voltage supply (VM) range from 4.5-V to 32-V. A 0.1- μ F ceramic capacitor rated for VM must be placed as close to the device as possible. In addition, a bulk capacitor must be included on the VM pin but can be shared with the bulk bypass capacitance for the external power MOSFETs.

10.1 Bulk Capacitance Sizing

Having appropriate local bulk capacitance is an important factor in motor drive system design. It is generally beneficial to have more bulk capacitance, while the disadvantages are increased cost and physical size. The amount of local capacitance depends on a variety of factors including:

- The highest current required by the motor system
- The power supply's type, capacitance, and ability to source current
- The amount of parasitic inductance between the power supply and motor system
- The acceptable supply voltage ripple
- Type of motor (brushed DC, brushless DC, stepper)
- The motor startup and braking methods

The inductance between the power supply and motor drive system will limit the rate of change of current from the power supply. If the local bulk capacitance is too small, the system will respond to excessive current demands or dumps from the motor with a change in voltage. When adequate bulk capacitance is used, the motor voltage remains stable and high current can be quickly supplied.

The data sheet provides a recommended minimum value, but system level testing is required to determine the appropriate sized bulk capacitor.

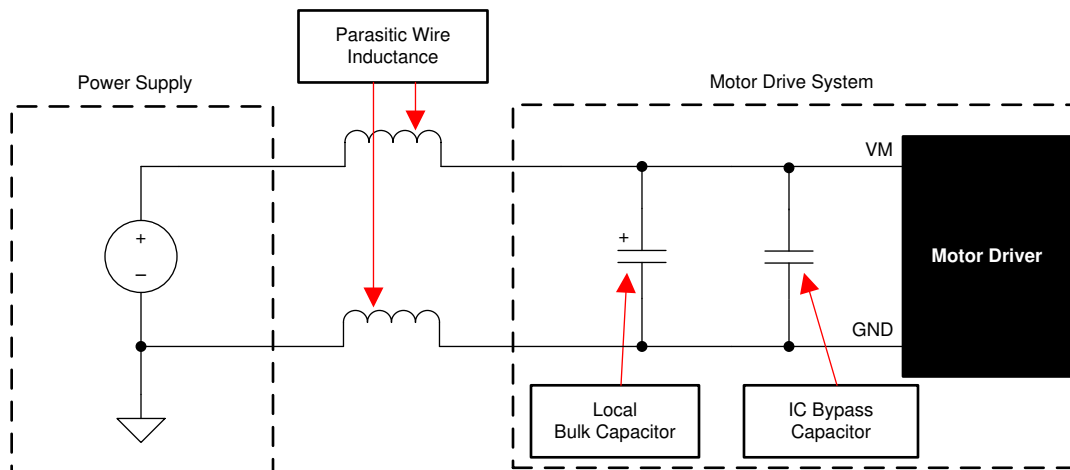

Figure 162. Motor Drive Power Supply Parasitic Example

11 Layout

11.1 Layout Guidelines

Bypass the VM pin to the GND pin using a low-ESR ceramic bypass capacitor with a recommended value of 0.1 μF . Place this capacitor as close to the VM pin as possible with a thick trace or ground plane connected to the PGND pin. Additionally, bypass the VM pin using a bulk capacitor rated for VM. This component can be electrolytic. This capacitance must be at least 10 μF .

Bypass the VDD pin to the GND pin with a 0.1- μF low-ESR ceramic capacitor rated for 6.3 V (X5R or X7R). Place this capacitor as close to the pin as possible and minimize the path from the capacitor to the AGND pin.

11.2 Layout Example

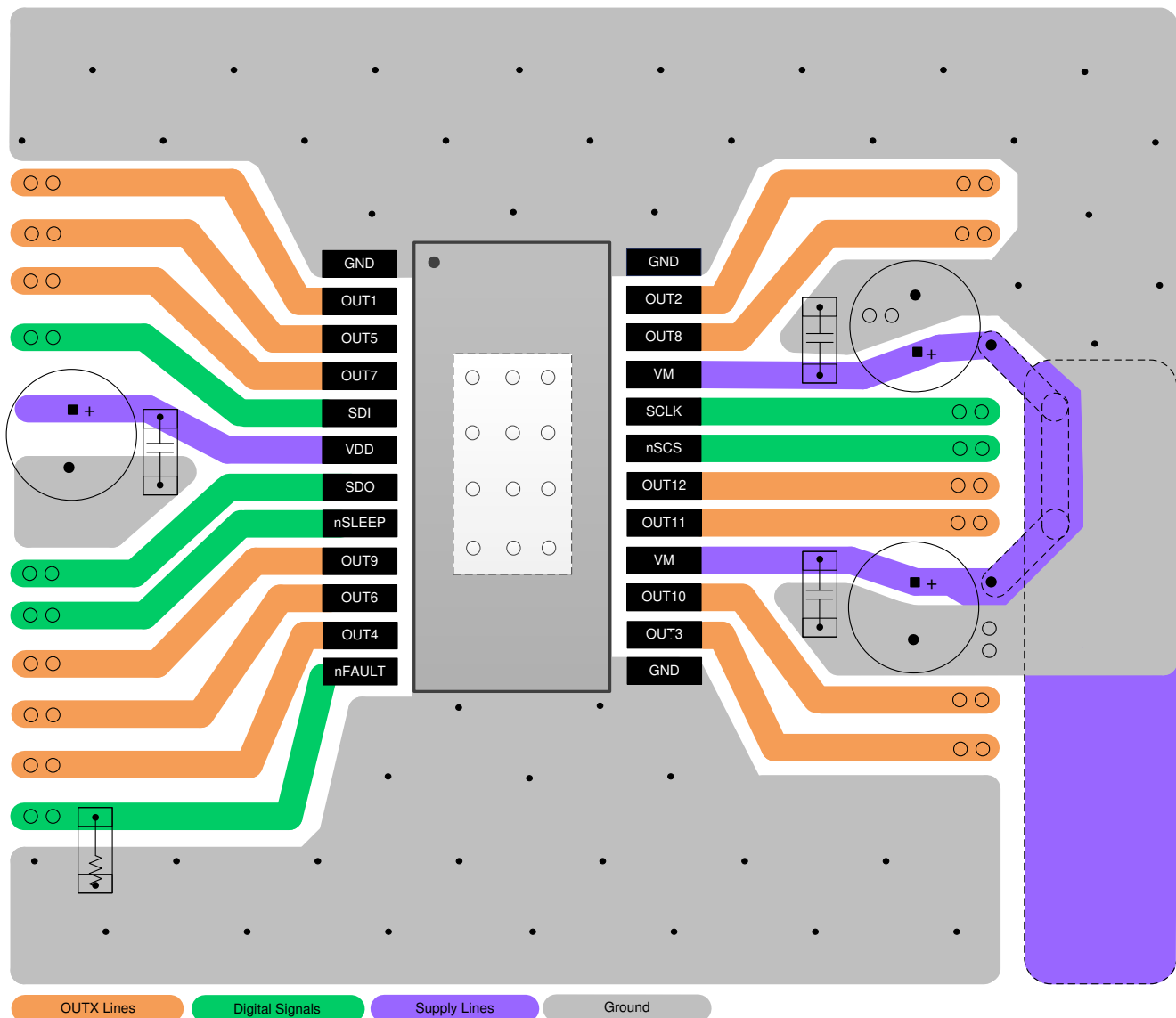

Figure 163. Layout Example

12 Device and Documentation Support

12.1 Documentation Support

12.1.1 Related Documentation

For related documentation see the following:

- Texas Instruments [DRV8912-Q1 Evaluation Module \(EVM\)](#)
- Texas Instruments [Motor Drives Layout Guide Application Report](#)

12.2 Related Links

The table below lists quick access links. Categories include technical documents, support and community resources, tools and software, and quick access to order now.

Table 96. Related Links

PARTS	PRODUCT FOLDER	ORDER NOW	TECHNICAL DOCUMENTS	TOOLS & SOFTWARE	SUPPORT & COMMUNITY
DRV8904-Q1	Click here	Click here	Click here	Click here	Click here
DRV8906-Q1	Click here	Click here	Click here	Click here	Click here
DRV8908-Q1	Click here	Click here	Click here	Click here	Click here
DRV8910-Q1	Click here	Click here	Click here	Click here	Click here
DRV8912-Q1	Click here	Click here	Click here	Click here	Click here

12.3 Receiving Notification of Documentation Updates

To receive notification of documentation updates, navigate to the device product folder on ti.com. In the upper right corner, click on *Alert me* to register and receive a weekly digest of any product information that has changed. For change details, review the revision history included in any revised document.

12.4 Community Resources

[TI E2E™ support forums](#) are an engineer's go-to source for fast, verified answers and design help — straight from the experts. Search existing answers or ask your own question to get the quick design help you need.

Linked content is provided "AS IS" by the respective contributors. They do not constitute TI specifications and do not necessarily reflect TI's views; see TI's [Terms of Use](#).

12.5 Trademarks

E2E is a trademark of Texas Instruments.

12.6 Electrostatic Discharge Caution



This integrated circuit can be damaged by ESD. Texas Instruments recommends that all integrated circuits be handled with appropriate precautions. Failure to observe proper handling and installation procedures can cause damage.

ESD damage can range from subtle performance degradation to complete device failure. Precision integrated circuits may be more susceptible to damage because very small parametric changes could cause the device not to meet its published specifications.

12.7 Glossary

[SLYZ022](#) — *TI Glossary*.

This glossary lists and explains terms, acronyms, and definitions.

13 Mechanical, Packaging, and Orderable Information

The following pages include mechanical, packaging, and orderable information. This information is the most current data available for the designated devices. This data is subject to change without notice and revision of this document. For browser-based versions of this data sheet, refer to the left-hand navigation.

PACKAGING INFORMATION

Orderable Device	Status (1)	Package Type	Package Drawing	Pins	Package Qty	Eco Plan (2)	Lead finish/ Ball material (6)	MSL Peak Temp (3)	Op Temp (°C)	Device Marking (4/5)	Samples
DRV8904QPWPRQ1	ACTIVE	HTSSOP	PWP	24	2000	RoHS & Green	NIPDAU	Level-3-260C-168 HR	-40 to 125	DRV8904	Samples
DRV8906QPWPRQ1	ACTIVE	HTSSOP	PWP	24	2000	RoHS & Green	NIPDAU	Level-3-260C-168 HR	-40 to 125	DRV8906	Samples
DRV8908QPWPRQ1	ACTIVE	HTSSOP	PWP	24	2000	RoHS & Green	NIPDAU	Level-3-260C-168 HR	-40 to 125	DRV8908	Samples
DRV8910QPWPRQ1	ACTIVE	HTSSOP	PWP	24	2000	RoHS & Green	NIPDAU	Level-3-260C-168 HR	-40 to 125	DRV8910	Samples
DRV8912QPWPRQ1	ACTIVE	HTSSOP	PWP	24	3000	RoHS & Green	NIPDAU	Level-3-260C-168 HR	-40 to 125	DRV8912	Samples

(1) The marketing status values are defined as follows:

ACTIVE: Product device recommended for new designs.

LIFEBUY: TI has announced that the device will be discontinued, and a lifetime-buy period is in effect.

NRND: Not recommended for new designs. Device is in production to support existing customers, but TI does not recommend using this part in a new design.

PREVIEW: Device has been announced but is not in production. Samples may or may not be available.

OBSELETE: TI has discontinued the production of the device.

(2) **RoHS:** TI defines "RoHS" to mean semiconductor products that are compliant with the current EU RoHS requirements for all 10 RoHS substances, including the requirement that RoHS substance do not exceed 0.1% by weight in homogeneous materials. Where designed to be soldered at high temperatures, "RoHS" products are suitable for use in specified lead-free processes. TI may reference these types of products as "Pb-Free".

RoHS Exempt: TI defines "RoHS Exempt" to mean products that contain lead but are compliant with EU RoHS pursuant to a specific EU RoHS exemption.

Green: TI defines "Green" to mean the content of Chlorine (Cl) and Bromine (Br) based flame retardants meet JS709B low halogen requirements of <=1000ppm threshold. Antimony trioxide based flame retardants must also meet the <=1000ppm threshold requirement.

(3) MSL, Peak Temp. - The Moisture Sensitivity Level rating according to the JEDEC industry standard classifications, and peak solder temperature.

(4) There may be additional marking, which relates to the logo, the lot trace code information, or the environmental category on the device.

(5) Multiple Device Markings will be inside parentheses. Only one Device Marking contained in parentheses and separated by a "~" will appear on a device. If a line is indented then it is a continuation of the previous line and the two combined represent the entire Device Marking for that device.

(6) Lead finish/Ball material - Orderable Devices may have multiple material finish options. Finish options are separated by a vertical ruled line. Lead finish/Ball material values may wrap to two lines if the finish value exceeds the maximum column width.

Important Information and Disclaimer: The information provided on this page represents TI's knowledge and belief as of the date that it is provided. TI bases its knowledge and belief on information provided by third parties, and makes no representation or warranty as to the accuracy of such information. Efforts are underway to better integrate information from third parties. TI has taken and continues to take reasonable steps to provide representative and accurate information but may not have conducted destructive testing or chemical analysis on incoming materials and chemicals. TI and TI suppliers consider certain information to be proprietary, and thus CAS numbers and other limited information may not be available for release.

In no event shall TI's liability arising out of such information exceed the total purchase price of the TI part(s) at issue in this document sold by TI to Customer on an annual basis.

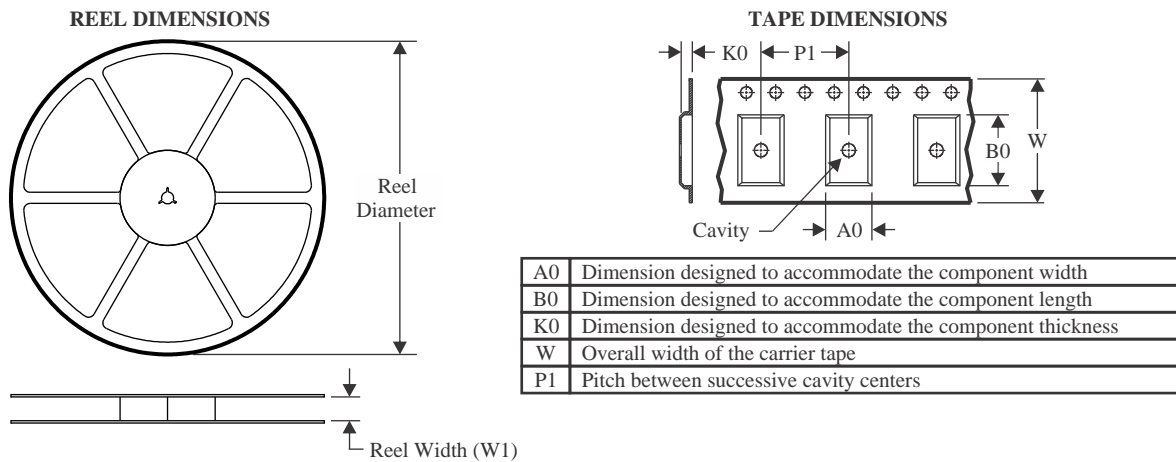
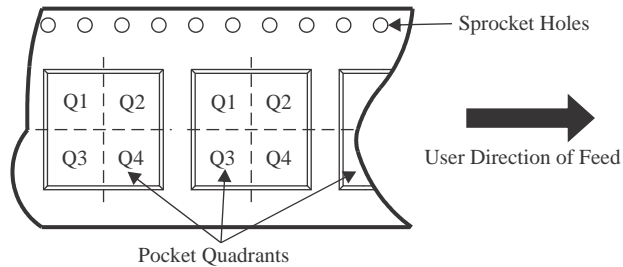
TAPE AND REEL INFORMATION

QUADRANT ASSIGNMENTS FOR PIN 1 ORIENTATION IN TAPE

*All dimensions are nominal

Device	Package Type	Package Drawing	Pins	SPQ	Reel Diameter (mm)	Reel Width W1 (mm)	A0 (mm)	B0 (mm)	K0 (mm)	P1 (mm)	W (mm)	Pin1 Quadrant
DRV8904QPWRQ1	HTSSOP	PWP	24	2000	330.0	16.4	6.95	8.3	1.6	8.0	16.0	Q1
DRV8906QPWRQ1	HTSSOP	PWP	24	2000	330.0	16.4	6.95	8.3	1.6	8.0	16.0	Q1
DRV8908QPWRQ1	HTSSOP	PWP	24	2000	330.0	16.4	6.95	8.3	1.6	8.0	16.0	Q1
DRV8910QPWRQ1	HTSSOP	PWP	24	2000	330.0	16.4	6.95	8.3	1.6	8.0	16.0	Q1
DRV8912QPWRQ1	HTSSOP	PWP	24	3000	330.0	16.4	6.95	8.3	1.6	8.0	16.0	Q1

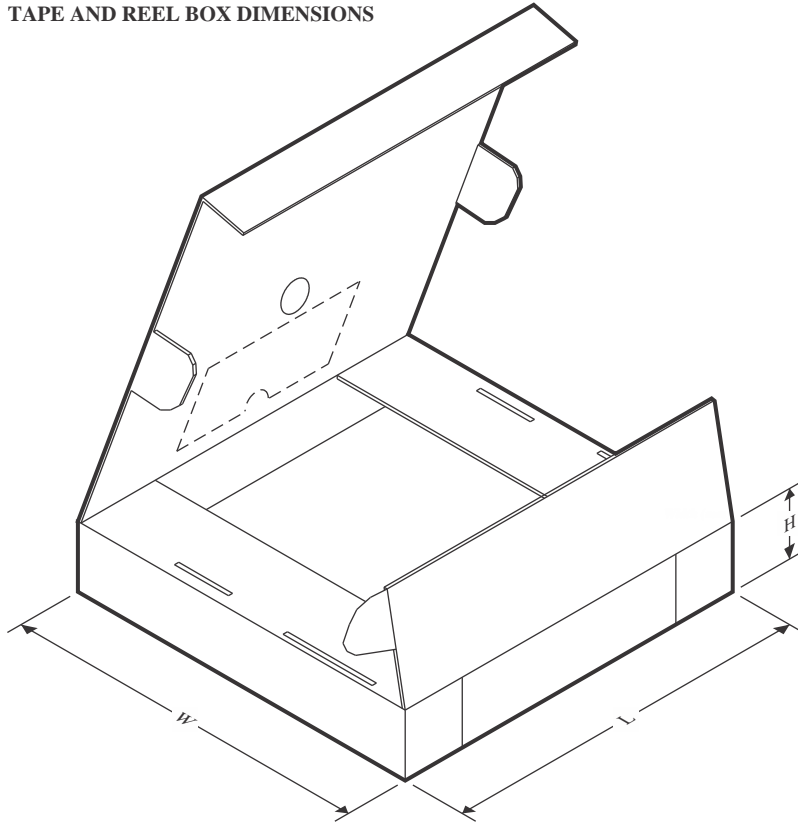
TAPE AND REEL BOX DIMENSIONS



*All dimensions are nominal

Device	Package Type	Package Drawing	Pins	SPQ	Length (mm)	Width (mm)	Height (mm)
DRV8904QPWPRQ1	HTSSOP	PWP	24	2000	356.0	356.0	35.0
DRV8906QPWPRQ1	HTSSOP	PWP	24	2000	356.0	356.0	35.0
DRV8908QPWPRQ1	HTSSOP	PWP	24	2000	356.0	356.0	35.0
DRV8910QPWPRQ1	HTSSOP	PWP	24	2000	356.0	356.0	35.0
DRV8912QPWPRQ1	HTSSOP	PWP	24	3000	356.0	356.0	35.0

GENERIC PACKAGE VIEW

PWP 24

PowerPAD™ TSSOP - 1.2 mm max height

4.4 x 7.6, 0.65 mm pitch

PLASTIC SMALL OUTLINE

This image is a representation of the package family, actual package may vary.
Refer to the product data sheet for package details.

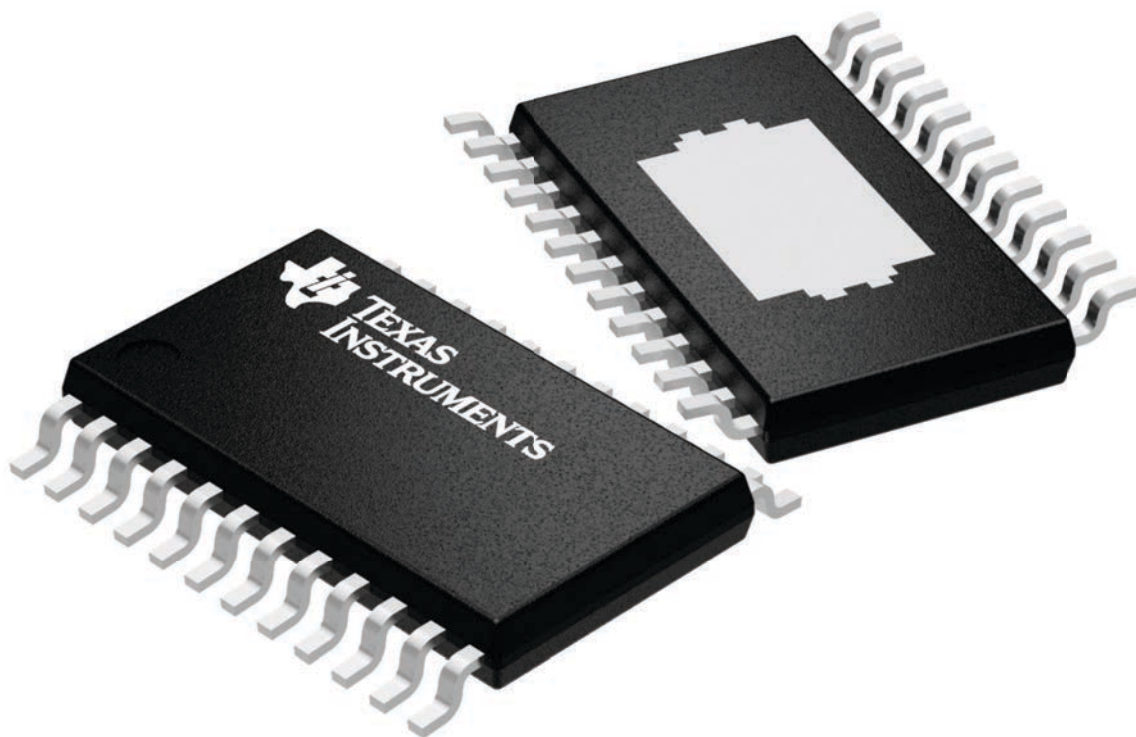

4224742/B

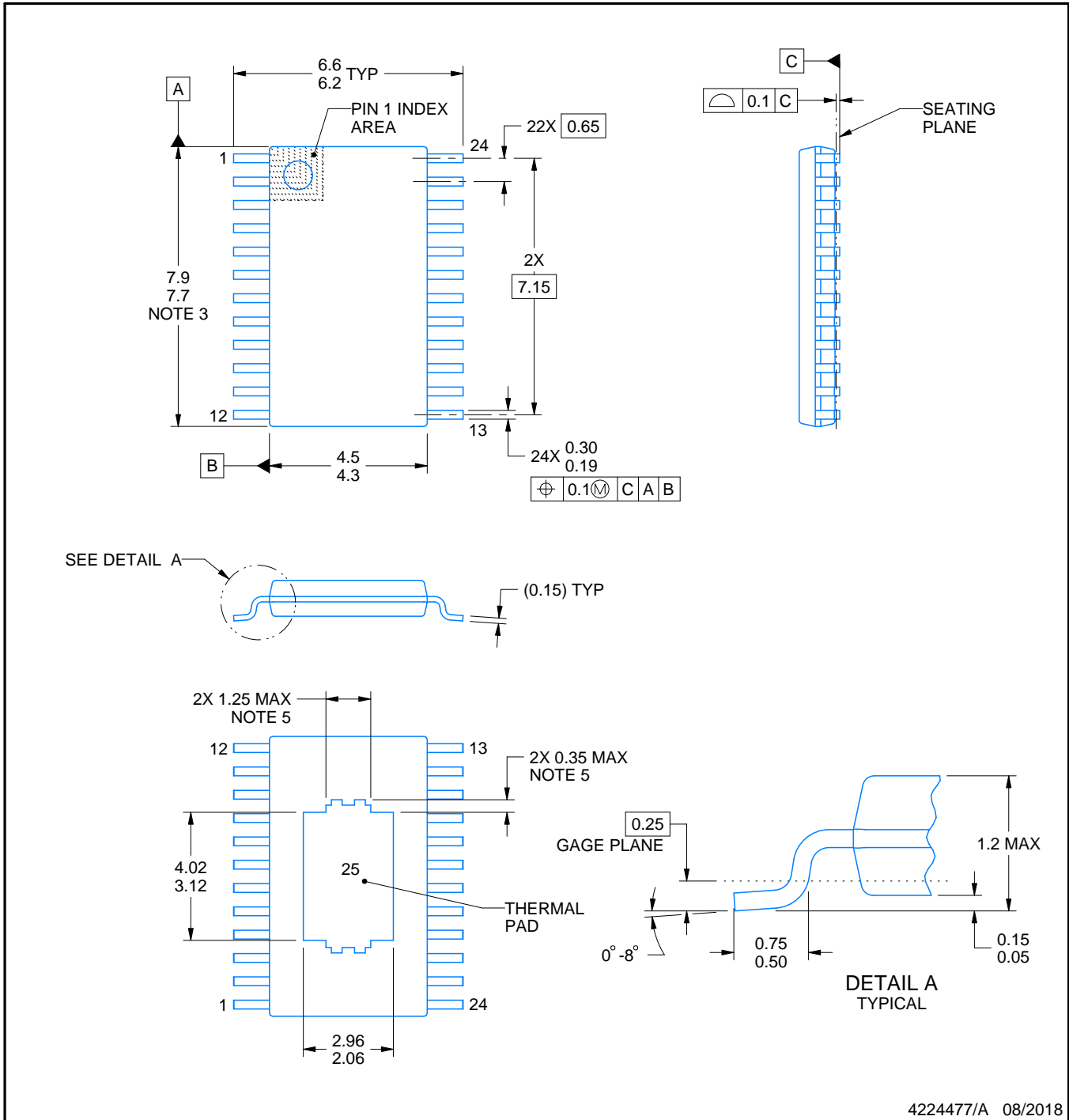
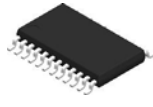

4224477/A 08/2018

NOTES:

PowerPAD is a trademark of Texas Instruments.

1. All linear dimensions are in millimeters. Any dimensions in parenthesis are for reference only. Dimensioning and tolerancing per ASME Y14.5M.
2. This drawing is subject to change without notice.
3. This dimension does not include mold flash, protrusions, or gate burrs. Mold flash, protrusions, or gate burrs shall not exceed 0.15 mm per side.
4. Reference JEDEC registration MO-153.
5. Features may differ or may not be present.

EXAMPLE BOARD LAYOUT

PWP0024N

PowerPAD™ TSSOP - 1.2 mm max height

SMALL OUTLINE PACKAGE

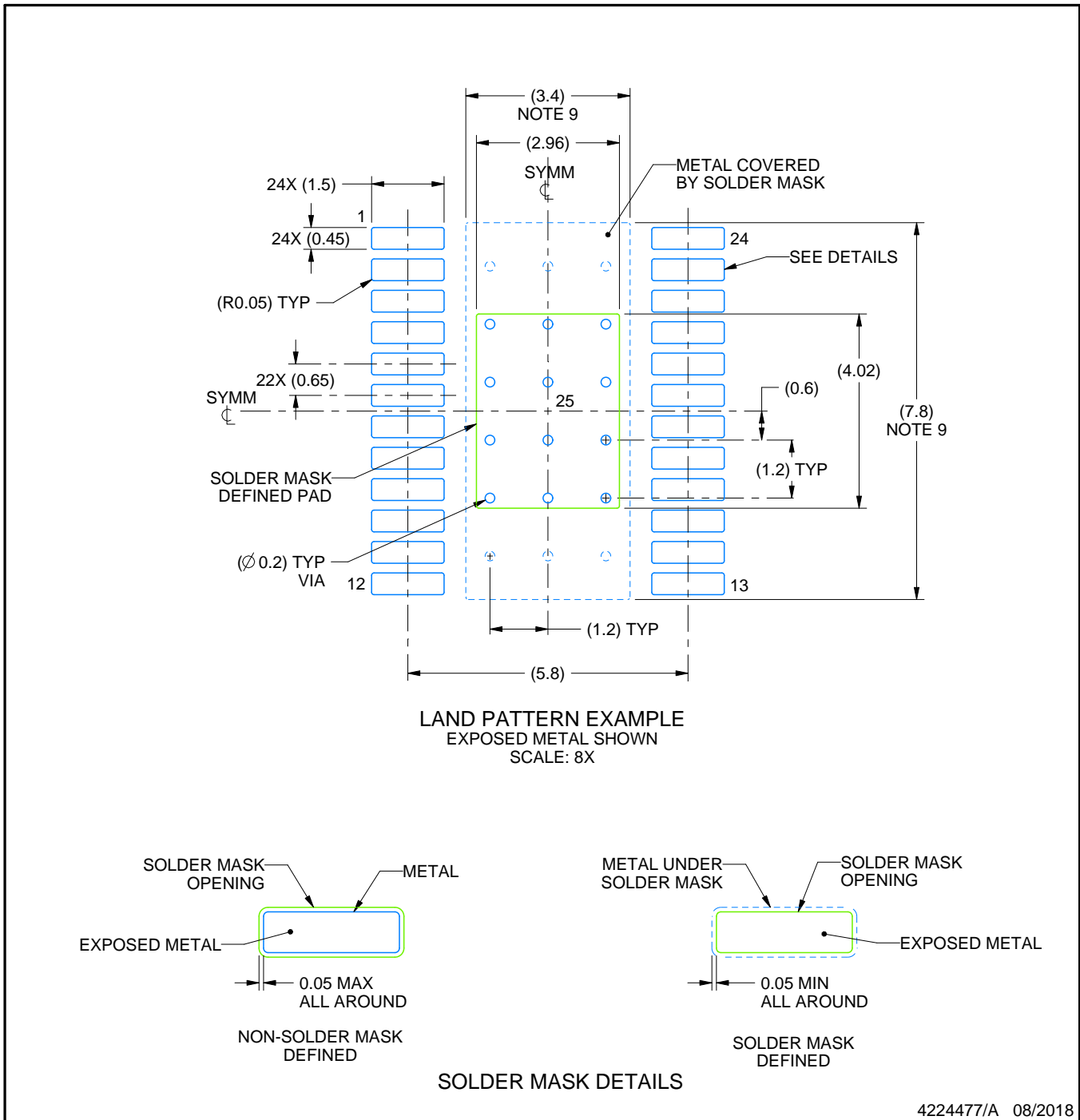

4224477/A 08/2018

NOTES: (continued)

6. Publication IPC-7351 may have alternate designs.
7. Solder mask tolerances between and around signal pads can vary based on board fabrication site.
8. This package is designed to be soldered to a thermal pad on the board. For more information, see Texas Instruments literature numbers SLMA002 (www.ti.com/lit/slma002) and SLMA004 (www.ti.com/lit/slma004).
9. Size of metal pad may vary due to creepage requirement.
10. Vias are optional depending on application, refer to device data sheet. It is recommended that vias under paste be filled, plugged or tented.

EXAMPLE STENCIL DESIGN

PWP0024N

PowerPAD™ TSSOP - 1.2 mm max height

SMALL OUTLINE PACKAGE

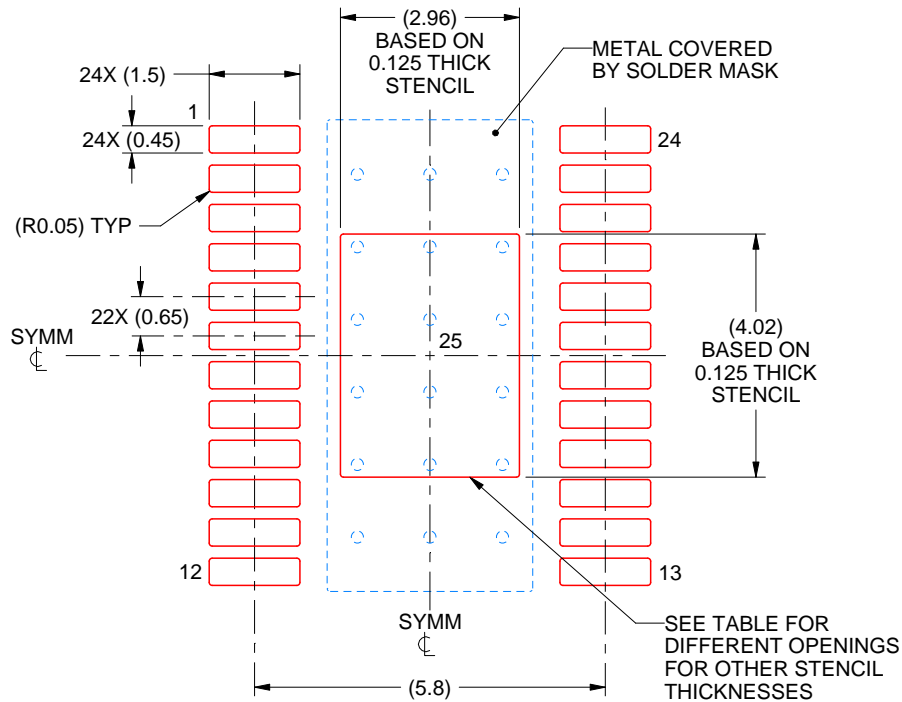

SOLDER PASTE EXAMPLE
BASED ON 0.125 mm THICK STENCIL
SCALE: 8X

STENCIL THICKNESS	SOLDER STENCIL OPENING
0.1	3.31 X 4.49
0.125	2.96 X 4.02 (SHOWN)
0.15	2.70 X 3.67
0.175	2.50 X 3.40

4224477/A 08/2018

NOTES: (continued)

11. Laser cutting apertures with trapezoidal walls and rounded corners may offer better paste release. IPC-7525 may have alternate design recommendations.
12. Board assembly site may have different recommendations for stencil design.

IMPORTANT NOTICE AND DISCLAIMER

TI PROVIDES TECHNICAL AND RELIABILITY DATA (INCLUDING DATA SHEETS), DESIGN RESOURCES (INCLUDING REFERENCE DESIGNS), APPLICATION OR OTHER DESIGN ADVICE, WEB TOOLS, SAFETY INFORMATION, AND OTHER RESOURCES "AS IS" AND WITH ALL FAULTS, AND DISCLAIMS ALL WARRANTIES, EXPRESS AND IMPLIED, INCLUDING WITHOUT LIMITATION ANY IMPLIED WARRANTIES OF MERCHANTABILITY, FITNESS FOR A PARTICULAR PURPOSE OR NON-INFRINGEMENT OF THIRD PARTY INTELLECTUAL PROPERTY RIGHTS.

These resources are intended for skilled developers designing with TI products. You are solely responsible for (1) selecting the appropriate TI products for your application, (2) designing, validating and testing your application, and (3) ensuring your application meets applicable standards, and any other safety, security, regulatory or other requirements.

These resources are subject to change without notice. TI grants you permission to use these resources only for development of an application that uses the TI products described in the resource. Other reproduction and display of these resources is prohibited. No license is granted to any other TI intellectual property right or to any third party intellectual property right. TI disclaims responsibility for, and you will fully indemnify TI and its representatives against, any claims, damages, costs, losses, and liabilities arising out of your use of these resources.

TI's products are provided subject to [TI's Terms of Sale](#) or other applicable terms available either on [ti.com](https://www.ti.com) or provided in conjunction with such TI products. TI's provision of these resources does not expand or otherwise alter TI's applicable warranties or warranty disclaimers for TI products.

TI objects to and rejects any additional or different terms you may have proposed.

Mailing Address: Texas Instruments, Post Office Box 655303, Dallas, Texas 75265
Copyright © 2024, Texas Instruments Incorporated

Looking for pricing, stock, or lifecycle information?

Click below to explore more details on WIN SOURCE:

 [View DS160PR412RUAR on WIN SOURCE](#)

 [Texas Instruments](#) Information

Optimize Your Supply Chain with WIN SOURCE Solutions

-  Global Sourcing Solution
-  Obsolete Management
-  Cost Control Management
-  Shortage Management
-  Alternative Solution
-  Excess Inventory Management