



**THE DATASHEET OF
CC11XLDK-868-915**



CC11xL 868/915 MHz Development Kit Quick Start Guide

Opening the Box and Running the Packet Error Rate Test

1. Kit Contents

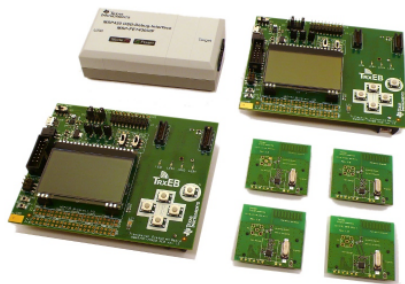

2 x SmartRF™ Transceiver EB (TrxEB)
 2 x CC110LEM 868/915 MHz
 1 x CC113LEM 868/915 MHz
 1 x CC115LEM 868/915 MHz
 1 x MSP430 Debug Probe (FET)
 2 x Micro USB Cables
 1 x Standard USB Cable
 1 x 14-pin Flat Cable
 4 x 1.5 Volt AA Batteries
 Documentation

2. TrxEB Overview

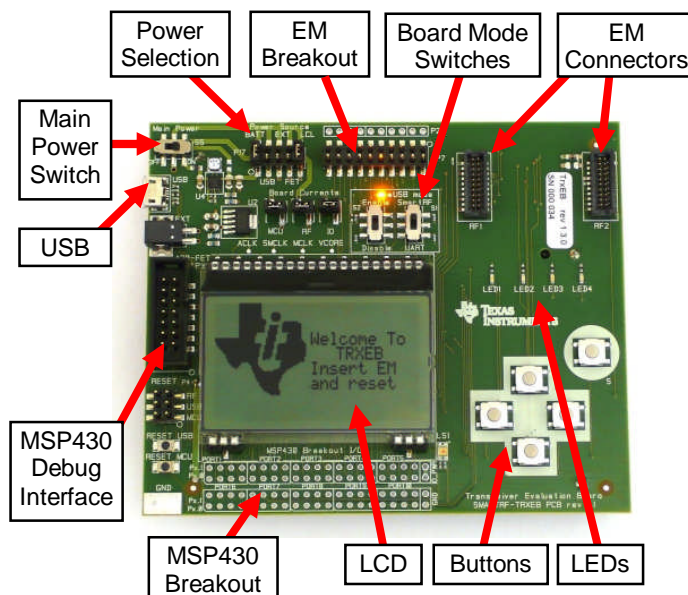

Caution! The kit contains ESD sensitive components. Handle with care to prevent permanent damage. To minimize risk of injury, avoid touching components during operation if symbolized as hot.

3. Plug the EM into the TrxEB

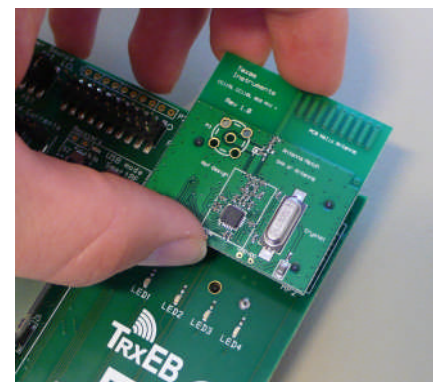

Insert a CC110LEM into the TrxEB. The connectors will only fit in one position so that the EM cannot be inserted the wrong way. Do not use excessive force on the EM.

The EM has a PCB antenna, so there is no need for an external antenna.

You can also use CC113L and CC115L for the Per test, but note that CC113L is a receiver only and CC115L is a transmitter only.

4. Select Board Mode

Use the switches S1 and S2 to select the operating mode of the board. For the sake of this quick start guide, please select “Enable” and “UART”. This configuration will make it possible to communicate directly with the MSP430 over a virtual COM port on the PC.

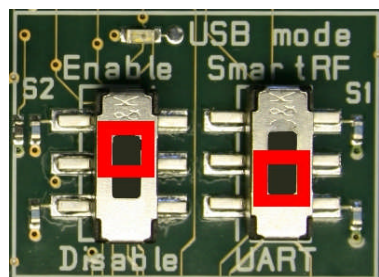

5. Power Options

There are several ways of applying power to the TrxEB.

- 2 x 1.5 V AA batteries
- USB
- External Power Supply
- MSP430 Debugger

For the batteries and USB, there are voltage regulators on the TrxEB that will set the on-board voltage to 3.3 V. The external power supply should set a voltage that does not exceed 3.3 V. By default, the MSP430 debugger supplies 3.0 V. **Note that there should only be one active power source at any one time.**

Warning! To minimize risk of personal injury or property damage, never use rechargeable batteries to power the board. Do not leave the EVM powered when unattended.

6. Select Power Source

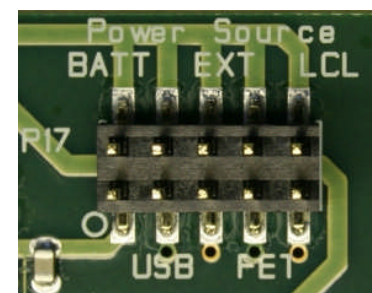

Depending on the power source, make sure you connect jumpers to the appropriate pins on the “Power Source” header. For instance, if you use batteries, use a jumper to short-circuit pin 1 and 2 on the header. The last jumper in the row (pin 9-10) should always be mounted, unless the MSP430 FET is used as the power source.

7. Welcome Screen

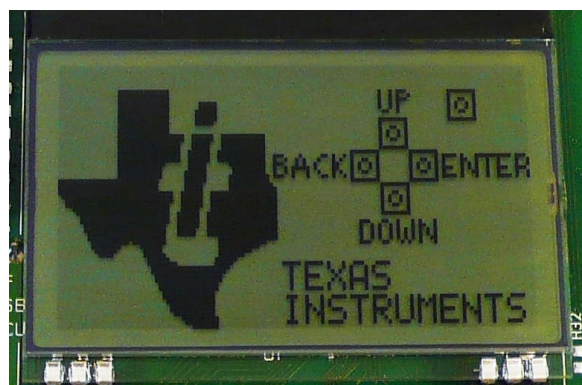

Turn on power with the Main Power switch. You should now see the Texas Instruments logo and a short description of the buttons on the LCD. Pushing any of the five buttons on the board will take you to the main menu.

NB! If you don't see anything on the screen – don't panic. First, make sure the mode switches are in the correct positions (see step 4 above). Secondly, the first build of TrxEB unfortunately uses a connector that doesn't fit exactly to the pins of the LCD. It should be sufficient to tilt the LCD slightly to get a snug fit with the connector.

8. Packet Error Rate Test

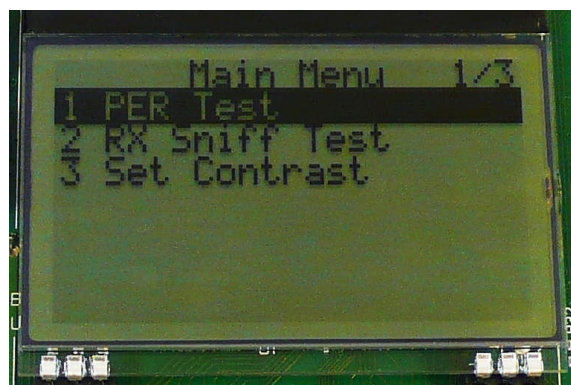

Select the PER (Packet Error Rate) test by highlighting the selection using the up/down buttons. Confirm your selection by pressing Enter (right button).

9. Select Test Mode

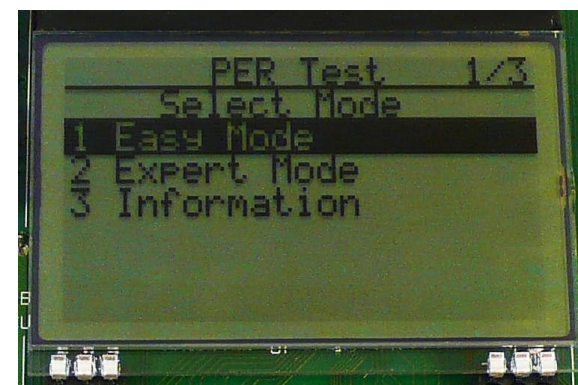

The PER test can be run in several modes. Easy Mode sets up a one-way test and uses default settings. This test is convenient for practical range testing.

The other test modes are described in the “**Software Examples for CC112x, CC11xL and CC1101 User's Guide**”.

To proceed, highlight “Easy Mode” and press Enter (right button).

10. Select Frequency

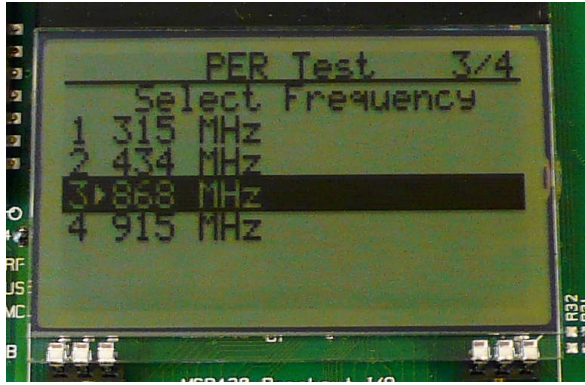

Select which frequency to use for the test. Make sure that the evaluation modules you have match the selected frequency.

11. Select Mode

One of the boards must operate as the slave (transmitter) and the other as master (receiver). Select Slave on one board...

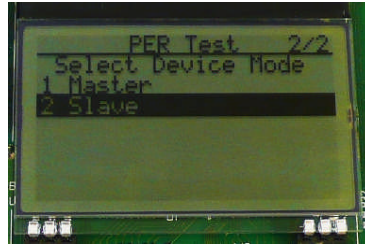

...and Master on the other board.

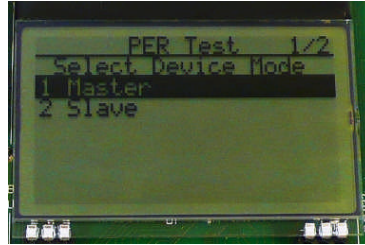

12. Establish Link

The slave node will now wait for a configuration package from the Master. The configuration contains the parameters used for the PER test.

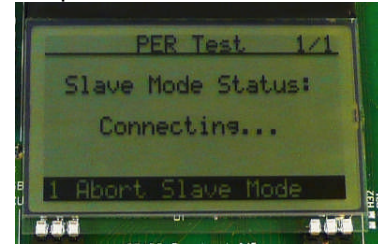

The configuration package will be sent when you select "link devices" on the master node.

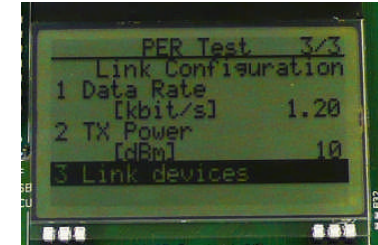

13. Link Established

When the initial linking has completed, the slave node will start the test by continuously transmitting packets to the master.

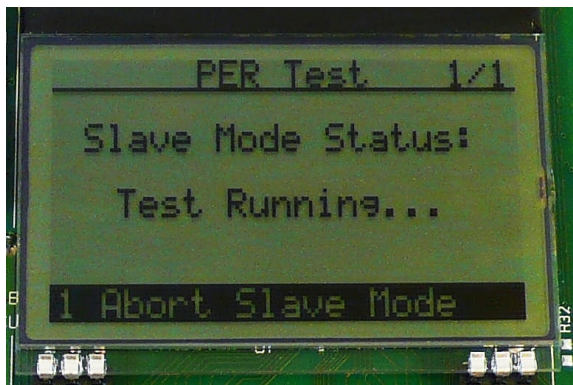

14. Start the Receiver (master)

On the master node, you can select the number of packets you want to receive in order to calculate the packet error.

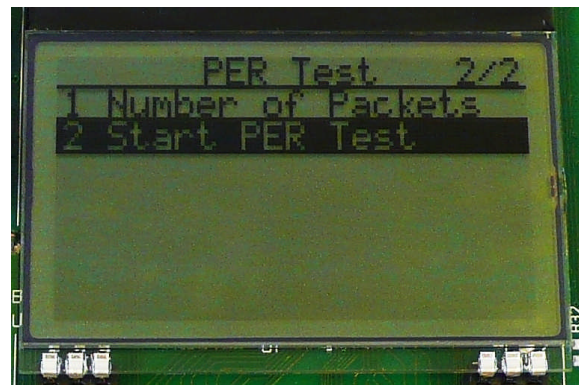

15. PER Test Results

The master will display a window that plots the received signal strength (RSSI) for each packet.

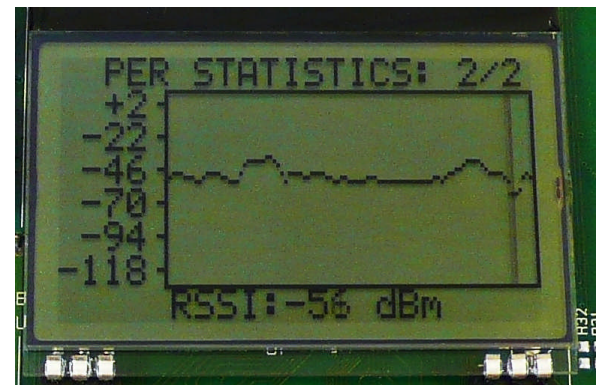

When selecting "Start PER Test", the master (receiver) will begin to count the number of received packets and provide some statistics.

Press the "Up" button to go to the detailed statistical window.

16. PER Test Results

The statistics window will show the error rate based on the number of lost or erroneous packets divided by the total number of packets that should have been received.

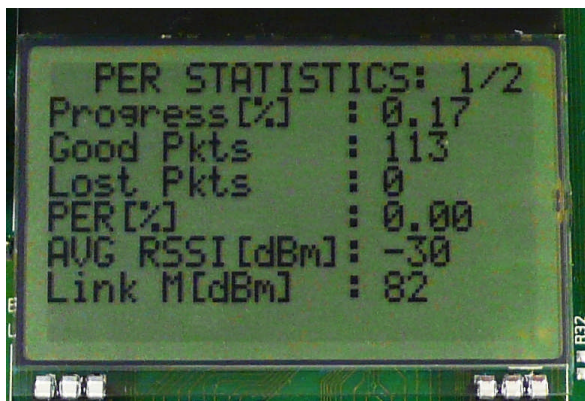

17. Troubleshooting

If you are experiencing problems with this test, please check the following:

- Nothing is shown in the display! Unfortunately, the first series of TrxEB uses a connector that doesn't fit exactly to the pins of the LCD. It should be sufficient to tilt the LCD slightly to get a snug fit with the connector.
- Please visit the kit web page and check for updated SW and documentation. Updated SW can be downloaded to the device using IAR EW430 or SmartRF Flash Programmer.
- If you get poor PER results at short distances, try to move the transmitter and receiver further apart. The CC11xL receiver may experience saturation if it is too close to the other CC11xL transmitting at full output power.

18. References

Please visit www.ti.com and

<http://www.ti.com/tool/cc11xldk-868-915>

On the kit product page, you will find additional documentation, links to updated software examples and software tools like SmartRF Studio.

You will also find a lot of information on the TI E2E forum at <http://e2e.ti.com>

We hope that you will enjoy working with the CC110L, CC113L and CC115L devices.

SmartRF™ Studio

1. Download and Install

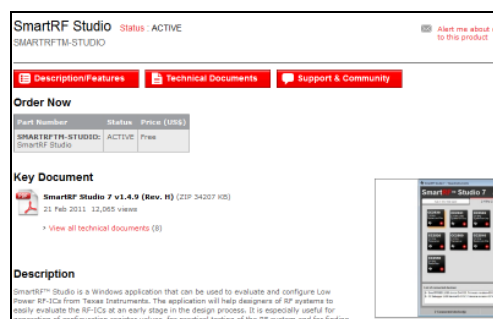

Before connecting SmartRF TrxEB to your PC, download and install SmartRF Studio from www.ti.com/smartrfstudio.

2. Launch SmartRF Studio



After installing the tool, connect the EB to the PC using the USB cable and start SmartRF Studio. Select the "Sub 1 GHz" tab and double click the highlighted device icon (CC110L, CC113L or CC115L).

3. Test the Radio

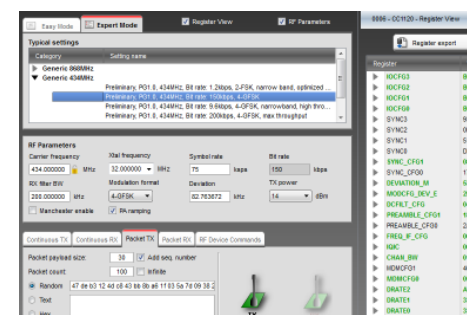

You can now configure the radio, export register settings and run performance tests of the radio.

IMPORTANT NOTICE

Texas Instruments Incorporated and its subsidiaries (TI) reserve the right to make corrections, modifications, enhancements, improvements, and other changes to its products and services at any time and to discontinue any product or service without notice. Customers should obtain the latest relevant information before placing orders and should verify that such information is current and complete. All products are sold subject to TI's terms and conditions of sale supplied at the time of order acknowledgment.

TI warrants performance of its hardware products to the specifications applicable at the time of sale in accordance with TI's standard warranty. Testing and other quality control techniques are used to the extent TI deems necessary to support this warranty. Except where mandated by government requirements, testing of all parameters of each product is not necessarily performed.

TI assumes no liability for applications assistance or customer product design. Customers are responsible for their products and applications using TI components. To minimize the risks associated with customer products and applications, customers should provide adequate design and operating safeguards.

TI does not warrant or represent that any license, either express or implied, is granted under any TI patent right, copyright, mask work right, or other TI intellectual property right relating to any combination, machine, or process in which TI products or services are used. Information published by TI regarding third-party products or services does not constitute a license from TI to use such products or services or a warranty or endorsement thereof. Use of such information may require a license from a third party under the patents or other intellectual property of the third party, or a license from TI under the patents or other intellectual property of TI.

Reproduction of TI information in TI data books or data sheets is permissible only if reproduction is without alteration and is accompanied by all associated warranties, conditions, limitations, and notices. Reproduction of this information with alteration is an unfair and deceptive business practice. TI is not responsible or liable for such altered documentation. Information of third parties may be subject to additional restrictions.

Resale of TI products or services with statements different from or beyond the parameters stated by TI for that product or service voids all express and any implied warranties for the associated TI product or service and is an unfair and deceptive business practice. TI is not responsible or liable for any such statements.

TI products are not authorized for use in safety-critical applications (such as life support) where a failure of the TI product would reasonably be expected to cause severe personal injury or death, unless officers of the parties have executed an agreement specifically governing such use. Buyers represent that they have all necessary expertise in the safety and regulatory ramifications of their applications, and acknowledge and agree that they are solely responsible for all legal, regulatory and safety-related requirements concerning their products and any use of TI products in such safety-critical applications, notwithstanding any applications-related information or support that may be provided by TI. Further, Buyers must fully indemnify TI and its representatives against any damages arising out of the use of TI products in such safety-critical applications.

TI products are neither designed nor intended for use in military/aerospace applications or environments unless the TI products are specifically designated by TI as military-grade or "enhanced plastic." Only products designated by TI as military-grade meet military specifications. Buyers acknowledge and agree that any such use of TI products which TI has not designated as military-grade is solely at the Buyer's risk, and that they are solely responsible for compliance with all legal and regulatory requirements in connection with such use.

TI products are neither designed nor intended for use in automotive applications or environments unless the specific TI products are designated by TI as compliant with ISO/TS 16949 requirements. Buyers acknowledge and agree that, if they use any non-designated products in automotive applications, TI will not be responsible for any failure to meet such requirements.

Following are URLs where you can obtain information on other Texas Instruments products and application solutions:

Products

Audio	www.ti.com/audio
Amplifiers	amplifier.ti.com
Data Converters	dataconverter.ti.com
DLP® Products	www.dlp.com
DSP	dsp.ti.com
Clocks and Timers	www.ti.com/clocks
Interface	interface.ti.com
Logic	logic.ti.com
Power Mgmt	power.ti.com
Microcontrollers	microcontroller.ti.com
RFID	www.ti-rfid.com
OMAP Mobile Processors	www.ti.com/omap
Wireless Connectivity	www.ti.com/wirelessconnectivity

Applications

Automotive and Transportation	www.ti.com/automotive
Communications and Telecom	www.ti.com/communications
Computers and Peripherals	www.ti.com/computers
Consumer Electronics	www.ti.com/consumer-apps
Energy and Lighting	www.ti.com/energy
Industrial	www.ti.com/industrial
Medical	www.ti.com/medical
Security	www.ti.com/security
Space, Avionics and Defense	www.ti.com/space-avionics-defense
Video and Imaging	www.ti.com/video

TI E2E Community Home Page

e2e.ti.com

Mailing Address: Texas Instruments, Post Office Box 655303, Dallas, Texas 75265
Copyright © 2012, Texas Instruments Incorporated



Looking for pricing, stock, or lifecycle information?

Click below to explore more details on WIN SOURCE:

 [View CC11XLDK-868-915 on WIN SOURCE](#)

 [Texas Instruments](#) Information

Optimize Your Supply Chain with WIN SOURCE Solutions

-  Global Sourcing Solution
-  Obsolete Management
-  Cost Control Management
-  Shortage Management
-  Alternative Solution
-  Excess Inventory Management