



**THE DATASHEET OF  
DS28E04S-100+T**





## DS28E04-100

### 4096-Bit Addressable 1-Wire EEPROM with PIO

#### GENERAL DESCRIPTION

The DS28E04-100 is a 4096-bit, 1-Wire<sup>®</sup> EEPROM chip with seven address inputs. The address inputs are directly mapped into the 1-Wire 64-bit Device ID Number to easily enable the host system to identify the physical location or functional association of the DS28E04-100 in a multidevice 1-Wire network environment. The 4096-bit EEPROM array is configured as 16 pages of 32 bytes with a 32 byte scratchpad to perform write operations. EEPROM memory pages can be individually write protected or put in EPROM-emulation mode, where bits can only be changed from a 1 to a 0 state. In addition to the memory, the DS28E04-100 has two general-purpose I/O ports that can be used for input or to generate level and/or pulse outputs. Activity registers also capture port activity for state change monitoring. The DS28E04-100 communicates over the single-contact 1-Wire bus. The communication follows the standard Maxim 1-Wire protocol.

#### APPLICATIONS

Autoconfiguration of Modular Systems such as  
Central-Office Switches, Cellular Base Stations,  
Access Products, Optical Network Units, and  
PBXs

Accessory/PCB Identification

#### TYPICAL OPERATING CIRCUIT

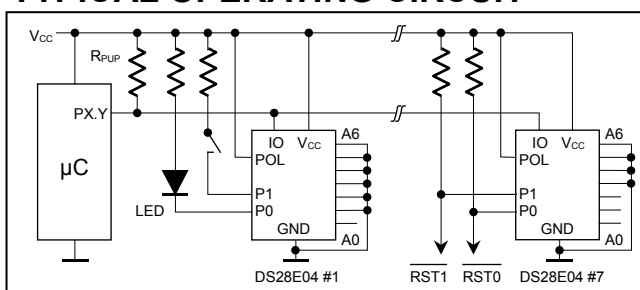

#### FEATURES

- 4096 bits of EEPROM Memory Partitioned into 16 Pages of 256 Bits
- Seven Address Inputs for Physical Location Configuration
- Two General-Purpose PIO Pins with Pulse-Generation Capability
- Individual Memory Pages can be Permanently Write-Protected or put in OTP EPROM-Emulation Mode (“Write to 0”)
- Communicates to Host with a Single Digital Signal at 15.3kbps or 111kbps Using 1-Wire Protocol
- Parasitic or V<sub>CC</sub> Powered
- Conditional Search Based on PIO Status or PIO Activity
- Switchpoint Hysteresis and Filtering to Optimize Performance in the Presence of Noise
- Reads and Writes Over a Wide 2.8V to 5.25V Voltage Range from -40°C to +85°C
- 16-Pin, 150-mil SO Package

#### ORDERING INFORMATION

PART	TEMP RANGE	PIN-PACKAGE
DS28E04S-100+	-40°C to +85°C	16 SO
DS28E04S-100+T	-40°C to +85°C	16 SO (2.5k pieces)

+ Indicates lead(Pb)-free/RoHS-compliant package.

T = Tape and reel.

#### PIN CONFIGURATION

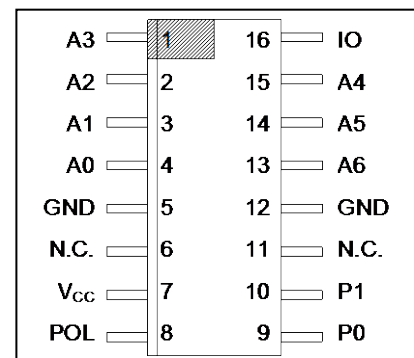

SO (150 mils)

Commands, Registers, and Modes are capitalized for clarity.

1-Wire is a registered trademark of Maxim Integrated Products, Inc.

**ABSOLUTE MAXIMUM RATINGS**

All Pins: Voltage to GND	-0.5V, +6V
All Pins: Sink Current	20mA
Operating Temperature Range	-40°C to +85°C
Junction Temperature	+150°C
Storage Temperature Range	-55°C to +125°C
Lead Temperature (soldering, 10s)	+300°C
Soldering Temperature (reflow)	+260°C

Stresses beyond those listed under "Absolute Maximum Ratings" may cause permanent damage to the device. These are stress ratings only, and functional operation of the device at these or any other conditions beyond those indicated in the operational sections of the specifications is not implied. Exposure to the absolute maximum rating conditions for extended periods may affect device reliability.

**ELECTRICAL CHARACTERISTICS**

( $V_{PUP} = 2.8V$  to  $5.25V$ ,  $V_{CC} = V_{PUP}$ , not connected or grounded,  $T_A = -40^\circ C$  to  $+85^\circ C$ .)

PARAMETER	SYMBOL	CONDITIONS	MIN	TYP	MAX	UNITS
Ground Current	$I_{GND}$	(Notes 1, 2, 3)			20	mA
Supply Current	$I_{CC}$	$V_{CC} = V_{PUP}$ (Note 3)			1	mA
Standby Supply Current	$I_{CCS}$	Device idle; A0 to A6 not connected			11	$\mu A$
<b>PINS A0 TO A6</b>						
Input Low Voltage	$V_{ILA}$	(Note 1)			0.30	V
Input High Voltage	$V_{IHA}$	$V_X = \max(V_{PUP}, V_{CC})$ (Note 1)	$V_X - 0.3V$			V
Input Load Current	$I_{LA}$	Pin at GND (Note 4)	-1.1			$\mu A$
<b>POL PIN</b>						
Input Low Voltage	$V_{ILPOL}$	(Note 1)			0.30	V
Input High Voltage	$V_{IHPOL}$	$V_X = \max(V_{PUP}, V_{CC})$ (Note 1)	$V_X - 0.3V$			V
Leakage Current	$I_{LKPOL}$	Pin at 5.25V			1	$\mu A$
<b>PIO PINS</b>						
Input Low Voltage	$V_{ILP}$	(Note 1)			0.30	V
Input High Voltage	$V_{IHP}$	$V_X = \max(V_{PUP}, V_{CC})$ (Note 1)	$V_X - 0.3V$			V
Output Low Voltage at 4mA	$V_{OLP}$	(Note 5)			0.4	V
Leakage Current	$I_{LKP}$	Pin at 5.25V			1	$\mu A$
Minimum Sensed PIO Pulse	$t_{PWMIN}$	(Note 6)	1		10	$\mu s$
Output Pulse Duration	$t_{PULSE}$	(Note 7)	250		1000	ms
<b>IO PIN GENERAL DATA</b>						
1-Wire Pullup Resistance	$R_{PUP}$	(Notes 1, 8)	0.3		2.2	k $\Omega$
Input Capacitance	$C_{IO}$	(Notes 3, 9)		100	800	pF
Input Load Current	$I_L$	IO pin at $V_{PUP}$ , A0 to A6 not connected, $V_{CC}$ at GND	0.05		11.00	$\mu A$
		IO pin at $V_{PUP}$ , A0 to A6 not connected, $V_{CC}$ at $V_{PUP}$	0.05		8.25	
High-to-Low Switching Threshold	$V_{TL}$	(Notes 3, 10, 11)	0.46		4.40	V
Input Low Voltage	$V_{IL}$	(Notes 1, 12)			0.3	V
Input High Voltage	$V_{IH}$	$V_X = \max(V_{PUP}, V_{CC})$ (Note 1)	$V_X - 0.3V$			V
Low-to-High Switching Threshold	$V_{TH}$	(Notes 3, 10, 13)	1.0		4.9	V
Switching Hysteresis	$V_{HY}$	(Notes 3, 10, 14)	0.21		1.70	V
Output Low Voltage	$V_{OL}$	At 4mA Current Load (Note 5)			0.4	V
Recovery Time (Notes 1, 15)	$t_{REC}$	Standard speed, $R_{PUP} = 2.2k\Omega$	5			$\mu s$
		Overdrive speed, $R_{PUP} = 2.2k\Omega$	2			
		Overdrive speed, directly prior to reset pulse; $R_{PUP} = 2.2k\Omega$	5			
Rising-Edge Hold-Off Time (Note 3)	$t_{REH}$	Standard speed (Note 16)	0.5		5.0	$\mu s$
		Overdrive speed	Not applicable (0)			

PARAMETER	SYMBOL	CONDITIONS	MIN	TYP	MAX	UNITS
Time Slot Duration (Note 1)	$t_{\text{SLOT}}$	Standard speed	65			$\mu\text{s}$
		Overdrive speed	9			
<b>IO PIN, 1-Wire RESET, PRESENCE DETECT CYCLE</b>						
Reset Low Time (Note 1)	$t_{\text{RSTL}}$	Standard speed, $V_{\text{PUP}} > 4.5\text{V}$	480		640	$\mu\text{s}$
		Standard speed (Note 17)	504		640	
		Overdrive speed, $V_{\text{PUP}} > 4.5\text{V}$	48		80	
		Overdrive speed (Note 17)	53		80	
Presence-Detect High Time	$t_{\text{PDH}}$	Standard speed	15		60	$\mu\text{s}$
		Overdrive speed (Note 17)	2		7	
Presence-Detect Fall Time (Notes 3, 18)	$t_{\text{FPD}}$	Standard speed, $V_{\text{PUP}} > 4.5\text{V}$	1.10		3.75	$\mu\text{s}$
		Standard speed	1.1		7.0	
		Overdrive speed	0		1.1	
Presence-Detect Low Time	$t_{\text{PDL}}$	Standard speed	60		240	$\mu\text{s}$
		Overdrive speed, $V_{\text{PUP}} > 4.5\text{V}$	8		24	
		Overdrive speed (Note 17)	8		26	
Presence-Detect Sample Time (Note 1)	$t_{\text{MSP}}$	Standard speed, $V_{\text{PUP}} > 4.5\text{V}$	64		75	$\mu\text{s}$
		Standard speed	67		75	
		Overdrive speed	8.1		10	
<b>IO PIN, 1-Wire WRITE</b>						
Write-0 Low Time (Notes 1, 19)	$t_{\text{W0L}}$	Standard speed	60		120	$\mu\text{s}$
		Overdrive speed (Note 17)	7		16	
Write-1 Low Time (Notes 1, 19)	$t_{\text{W1L}}$	Standard speed	5		15	$\mu\text{s}$
		Overdrive speed	1		2	
<b>IO PIN, 1-Wire READ</b>						
Read Low Time (Notes 1, 20)	$t_{\text{RL}}$	Standard speed	5		$15 - \delta$	$\mu\text{s}$
		Overdrive speed	1		$2 - \delta$	
Read Sample Time (Notes 1, 20)	$t_{\text{MSR}}$	Standard speed	$t_{\text{RL}} + \delta$		15	$\mu\text{s}$
		Overdrive speed	$t_{\text{RL}} + \delta$		2	
<b>EEPROM</b>						
Programming Current	$I_{\text{PROG}}$	(Note 21)			1	$\text{mA}$
Programming Time	$t_{\text{PROG}}$	(Note 22)			10	$\text{ms}$
Write/Erase Cycles (Endurance) (Note 23)	$N_{\text{CY}}$	At $+25^\circ\text{C}$	200k			—
		At $+85^\circ\text{C}$ (worst case)	50k			
Data Retention (Notes 23, 24)	$t_{\text{DR}}$	At $+85^\circ\text{C}$ (worst case)	40			years

**Note 1:** System requirement.

**Note 2:** Maximum instantaneous pulldown current through all pins combined.

**Note 3:** Guaranteed by design, simulation only. Not production tested.

**Note 4:** This load current is caused by the internal weak pullup, which asserts a logical 1 to address pins that are not connected. The logical state of the address pins must not change during the execution of ROM function commands during those time slots in which these bits are relevant.

**Note 5:** The I-V characteristic is linear for voltages less than 1V.

**Note 6:** Width of the narrowest pulse that trips the activity latch. Back to back pulses that are active for  $< t_{\text{PWMIN}}$  (max) and that have an intermediate inactive time  $< t_{\text{PWMIN}}$  (max) are not guaranteed to be filtered.

**Note 7:** The Pulse function requires that  $V_{\text{CC}}$  power is available; otherwise the command will not be executed.

**Note 8:** Maximum allowable pullup resistance is a function of the number of 1-Wire devices in the system and 1-Wire recovery times. The specified value here applies to systems with only one device and with the minimum 1-Wire recovery times. For more heavily loaded systems, an active pullup such as that found in the DS2482-x00, DS2480B, or DS2490 may be required.

**Note 9:** Capacitance on the data pin could be 800pF when  $V_{\text{PUP}}$  is first applied. If a 2.2k $\Omega$  resistor is used to pull up the data line, 2.5 $\mu\text{s}$  after  $V_{\text{PUP}}$  has been applied the parasitic capacitance will not affect normal communications.

**Note 10:**  $V_{\text{TL}}$ ,  $V_{\text{TH}}$ , and  $V_{\text{HY}}$  are a function of the internal supply voltage, which in parasite power mode, is a function of  $V_{\text{PUP}}$  and the 1-Wire recovery times. The  $V_{\text{TH}}$  and  $V_{\text{TL}}$  maximum specifications are valid at  $V_{\text{CC}} = V_{\text{PUP}} = 5.25\text{V}$ . In any case,  $V_{\text{TL}} < V_{\text{TH}} < V_{\text{PUP}}$ .

**Note 11:** Voltage below which, during a falling edge on IO, a logic 0 is detected.

**Note 12:** The voltage on IO needs to be less than or equal to  $V_{\text{ILMAX}}$  whenever the master drives the line low.

**Note 13:** Voltage above which, during a rising edge on IO, a logic 1 is detected.

**Note 14:** After  $V_{\text{TH}}$  is crossed during a rising edge on IO, the voltage on IO has to drop by at least  $V_{\text{HY}}$  to be detected as logic '0'.

**Note 15:** Applies to a single DS28E04-100 without  $V_{\text{CC}}$  supply, attached to a 1-Wire line.

**Note 16:** The earliest recognition of a negative edge is possible at  $t_{\text{REH}}$  after  $V_{\text{TH}}$  has been previously reached.

**Note 17:** Highlighted numbers are NOT in compliance with legacy 1-Wire product standards. See comparison table.

**Note 18:** Interval during the negative edge on IO at the beginning of a Presence Detect pulse between the time at which the voltage is 80% of  $V_{\text{PUP}}$  and the time at which the voltage is 20% of  $V_{\text{PUP}}$ .

- Note 19:**  $\epsilon$  in Figure 16 represents the time required for the pullup circuitry to pull the voltage on IO up from  $V_{IL}$  to  $V_{TH}$ . The actual maximum duration for the master to pull the line low is  $t_{W1LMAX} + t_F - \epsilon$  and  $t_{W0LMAX} + t_F - \epsilon$  respectively.
- Note 20:**  $\delta$  in Figure 16 represents the time required for the pullup circuitry to pull the voltage on IO up from  $V_{IL}$  to the input high threshold of the bus master. The actual maximum duration for the master to pull the line low is  $t_{RLMAX} + t_F$ .
- Note 21:** Current drawn during the EEPROM programming interval. If the device does not get  $V_{CC}$  power, the pullup circuit on IO during the programming interval should be such that the voltage at IO is greater than or equal to  $V_{PUP(min)}$ . If  $V_{PUP}$  in the system is close to  $V_{pup(min)}$  then a low-impedance bypass of  $R_{PUP}$  that can be activated during programming may need to be added.
- Note 22:** The  $t_{PROG}$  interval begins  $t_{REHmax}$  after the trailing rising edge on IO for the last time slot of the E/S byte for a valid Copy Scratchpad sequence. Interval ends once the device's self-timed EEPROM programming cycle is complete and the current drawn by the device has returned from  $I_{PROG}$  to  $I_L$  or  $I_{CCS}$ , respectively.
- Note 23:** Not production tested. Guaranteed by design or characterization.
- Note 24:** EEPROM writes can become nonfunctional after the data-retention time is exceeded. Long-time storage at elevated temperatures is not recommended; the device can lose its write capability after 10 years at +125°C or 40 years at +85°C.

PARAMETER	LEGACY VALUES				DS28E04-100 VALUES			
	STANDARD SPEED		OVERDRIVE SPEED		STANDARD SPEED		OVERDRIVE SPEED	
	MIN	MAX	MIN	MAX	MIN	MAX	MIN	MAX
$t_{SLOT}$ (incl. $t_{REC}$ )	61 $\mu$ s	(undef)	7 $\mu$ s	(undef)	65 $\mu$ s <sup>1)</sup>	(undef)	9 $\mu$ s	(undef)
$t_{RSTL}$	480 $\mu$ s	(undef)	48 $\mu$ s	80 $\mu$ s	504 $\mu$ s	640 $\mu$ s	53 $\mu$ s	80 $\mu$ s
$t_{PDH}$	15 $\mu$ s	60 $\mu$ s	2 $\mu$ s	6 $\mu$ s	15 $\mu$ s	60 $\mu$ s	2 $\mu$ s	7 $\mu$ s
$t_{PDL}$	60 $\mu$ s	240 $\mu$ s	8 $\mu$ s	24 $\mu$ s	60 $\mu$ s	240 $\mu$ s	8 $\mu$ s	26 $\mu$ s
$t_{WOL}$	60 $\mu$ s	120 $\mu$ s	6 $\mu$ s	16 $\mu$ s	60 $\mu$ s	120 $\mu$ s	7 $\mu$ s	16 $\mu$ s

<sup>1)</sup> Intentional change, longer recovery time requirement due to modified 1-Wire front end.

## PIN DESCRIPTION

PIN	NAME	FUNCTION
1	A3	Address bit input (place value = 8), with weak pullup.
2	A2	Address bit input (place value = 4), with weak pullup.
3	A1	Address bit input (place value = 2), with weak pullup.
4	A0	Least significant address bit input (place value = 1), with weak pullup.
5, 12	GND	Ground Reference
6, 11	N.C.	Not Connected
7	$V_{CC}$	Optional power supply for the chip; leave unconnected or ground if $V_{CC}$ power is not available.
8	POL	Power-up polarity (logical state) for P0 and P1; pin has a weak pulldown.
9	P0	Remote-controlled I/O pin, open drain with weak pulldown.
10	P1	Remote-controlled I/O pin, open drain with weak pulldown.
13	A6	Address bit input (place value = 64), with weak pullup.
14	A5	Address bit input (place value = 32), with weak pullup.
15	A4	Address bit input (place value = 16), with weak pullup.
16	IO	1-Wire Bus Interface. Open drain, requires external pullup resistor.

## DETAILED DESCRIPTION

The DS28E04-100 combines 4096 bits of EEPROM, a 16-byte control page, two general-purpose PIO pins, seven external address pins, and a fully featured 1-Wire interface in a single chip. PIO outputs are configured as open-drain and provide an on-resistance of 100 $\Omega$  max. A robust PIO channel-access communication protocol ensures that PIO output-setting changes occur error-free. The DS28E04-100 has an additional memory area called the scratchpad that acts as a buffer when writing to the main memory or the control page. Data is first written to the scratchpad from which it can be read back. The copy scratchpad command transfers the data to its final memory location. Each DS28E04-100 has a device ID number that is 64 bits long. The user can define seven bits of this number through address pins. The remaining 57 bits are factory-lasered into the chip. The device ID number guarantees unique identification and is used to address the device in a multidrop 1-Wire network environment, where multiple devices reside on a common 1-Wire bus and operate independently of each other. The DS28E04-100 also supports 1-Wire conditional search capability based on PIO conditions or power-on-reset activity. The DS28E04-100 has an optional  $V_{CC}$  supply connection. When an external supply is absent, device power is supplied parasitically from the 1-Wire bus. When an external supply is present, PIO states are maintained in the absence of the 1-Wire bus power source. Applications of the DS28E04-100 include autoconfiguration and state monitoring of modular systems such as central-office switches, cellular base stations, access products, optical network units, and PBXs, and accessory/PC board identification.

## OVERVIEW

The block diagram in Figure 1 shows the relationships between the major control and memory sections of the DS28E04-100. The DS28E04-100 has five main data components: 1) 64-bit device ID number, 2) 32-byte scratchpad, 3) sixteen 32-byte pages of EEPROM, 4) Special Function Register, and 5) PIO Control Registers. The hierarchical structure of the 1-Wire protocol is shown in Figure 2. The bus master must first provide one of the eight ROM Function Commands, 1) Read ROM, 2) Match ROM, 3) Search ROM, 4) Conditional Search ROM, 5) Skip ROM, 6) Resume, 7) Overdrive-Skip ROM or 8) Overdrive-Match ROM. Upon completion of an Overdrive ROM command byte executed at standard speed, the device enters Overdrive mode where all subsequent communication occurs at a higher speed. The protocol required for these ROM function commands is described in Figure 14. After a ROM function command is successfully executed, the memory/control functions become accessible and the master may provide any one of the nine Memory/Control Function commands. The protocol for these commands is described in Figure 9. **All data is read and written least significant bit first.**

**Figure 1. Block Diagram**

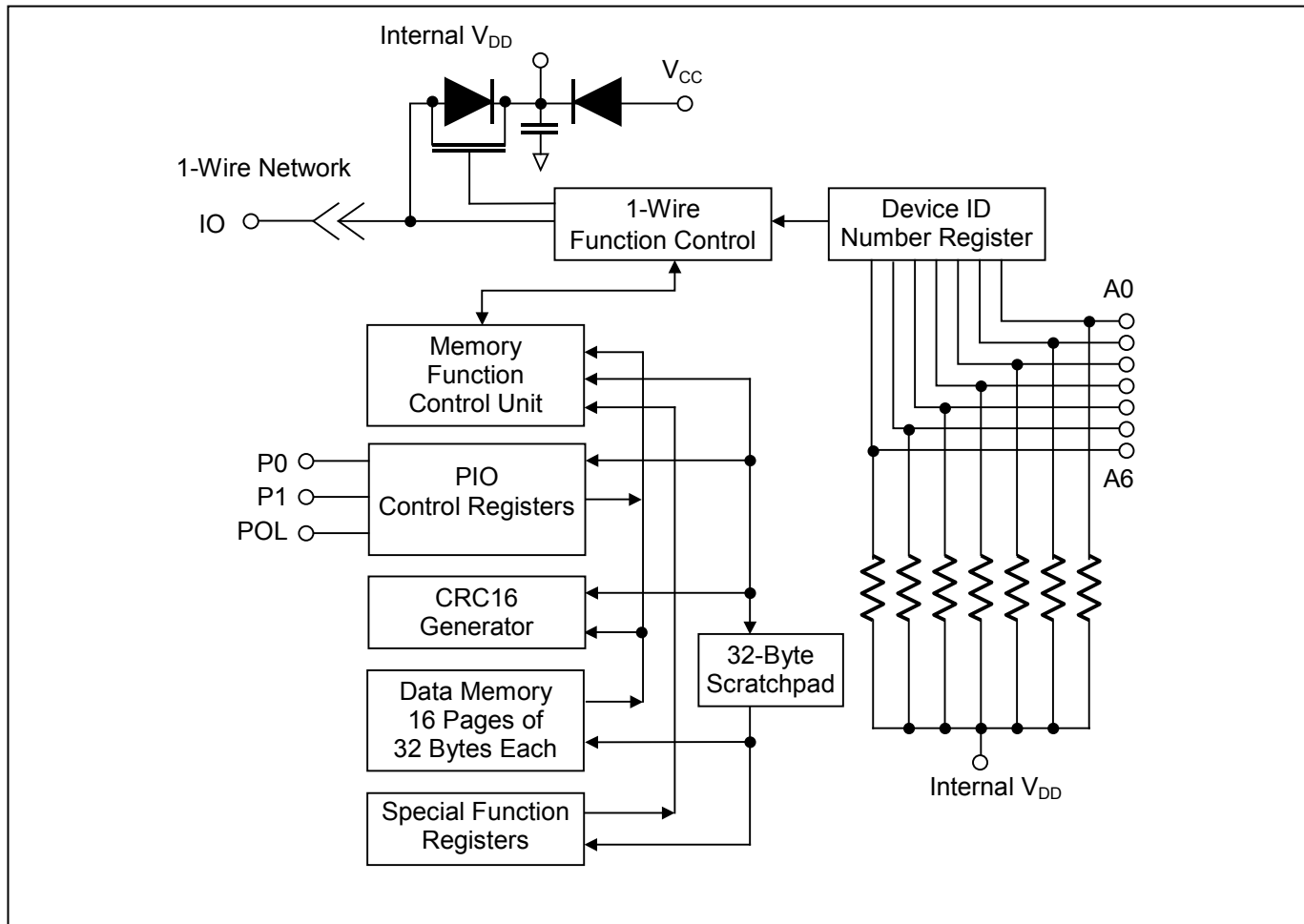

**Figure 2. Hierarchical Structure for 1-Wire Protocol**

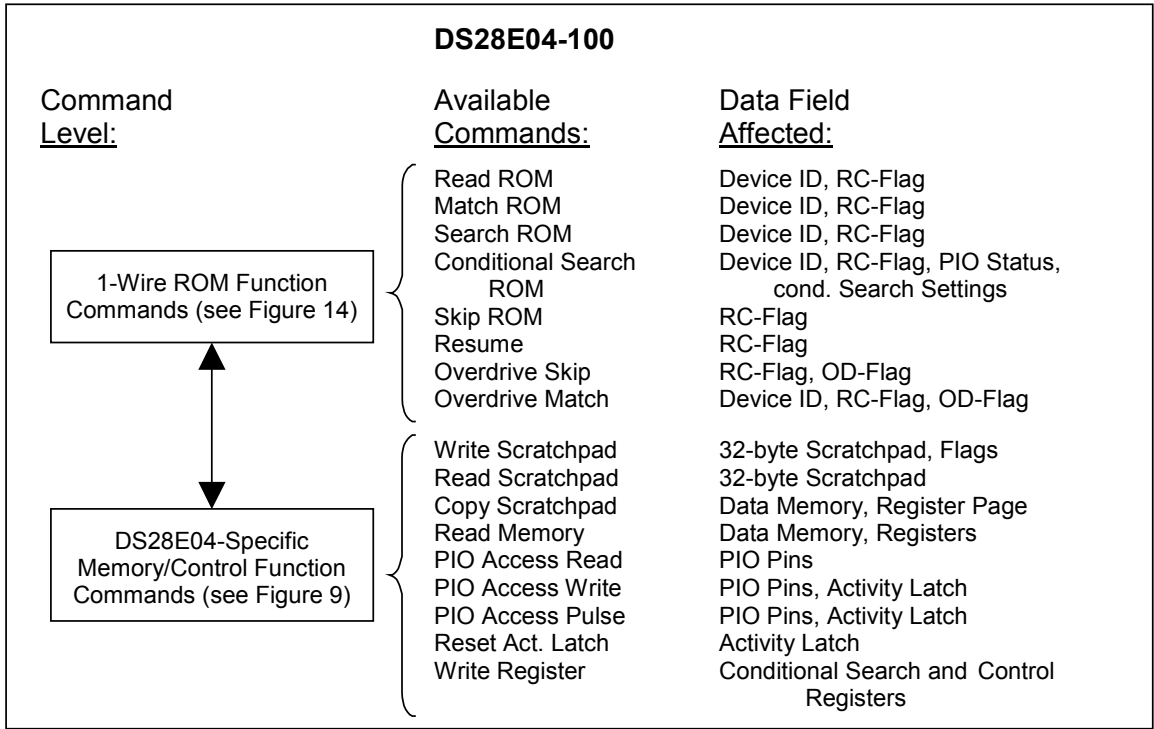

**64-BIT DEVICE ID NUMBER (NETWORK ADDRESS)**

Each DS28E04-100 has a unique device ID number that is 64 bits long, as shown in Figure 3. The first 8 bits are a 1-Wire family code. The next 8 bits are an external address byte, of which the lower 7 bits are connected to the address input pins A0 to A6. This allows the user to set a portion of the Device ID Number by connecting some of these pins to GND (logic 0) or to V<sub>CC</sub> (logic 1) or leaving them open (logic 1). The next 40 bits are a lasered serial number. Even if multiple DS28E04-100 are used in a 1-Wire network and all address inputs are wired to the same state or left open (unconnected), the unique 40-bit serialization field will prevent any address conflict, allowing to communicate with each device individually. The last 8 bits are a lasered CRC (Cyclic Redundancy Check) of the first 56 bits, assuming that the address input pins A0 to A6 are at logic 1. The 1-Wire CRC is generated using a polynomial generator consisting of a shift register and XOR gates as shown in Figure 4. The polynomial is  $X^8 + X^5 + X^4 + 1$ . Further information on the Device ID CRC is found in section *CRC Generation* near the end of this document.

**Figure 3. 64-Bit Device ID Number**

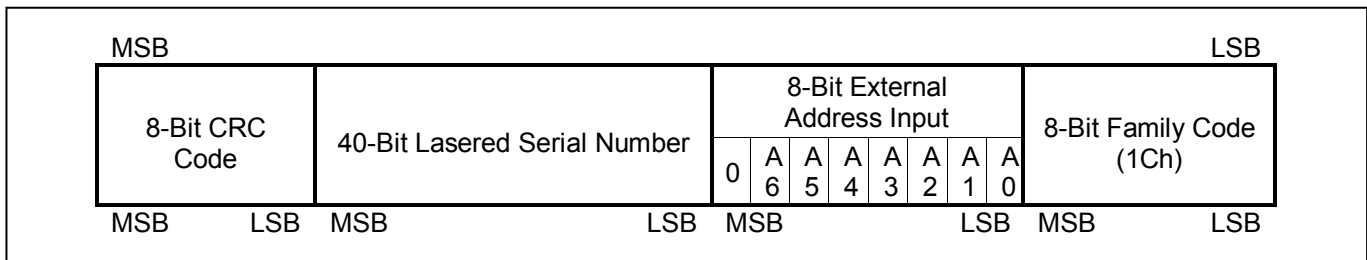

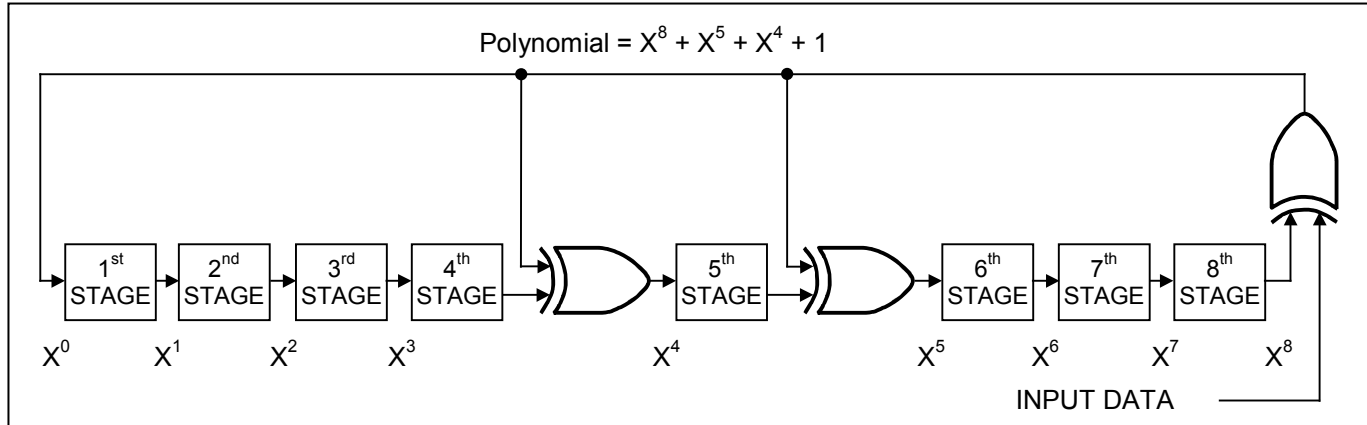
**Figure 4. 1-Wire CRC Generator**

## MEMORY

The DS28E04-100 EEPROM array consists of 17 pages of 32 bytes each, starting at address 0000h and ending at address 021Fh. All memory addresses in this range have unrestricted read access. The data memory consists of 16 pages of 32 bytes each. The register page consists of 32 bytes starting at address 0200h. It contains 16 page protection control bytes (one for each data memory page), the register page lock byte, the factory bytes, and the reserved bytes. The reserved bytes are for future use by the factory and should not be used. They have no effect on device operation.

The protection control registers, along with the register page lock byte, determine whether write protection, EPROM mode, or copy protection is enabled for each of the 16 data memory pages. A value of 55h sets write protection for the associated memory page. A value of AAh sets EPROM mode. A value of 55h or AAh for the register page lock byte sets copy protection for all write-protected data memory pages, as well as the register page. EPROM mode pages are not affected. The protection control registers and the register page lock byte write protect themselves if set to 55h or AAh. Any other setting leaves them open for unrestricted write access.

In addition to the EEPROM, the device has a 32-byte volatile scratchpad. Writes to the EEPROM array are a two-step process. First, data is written to the scratchpad through the Write Scratchpad command, and then copied into the main array through the Copy Scratchpad command. The user can verify the data written to the scratchpad through the Read Scratchpad command prior to copying into the main array.

If a memory location is write protected, data sent by the master to the associated address during a Write Scratchpad command is not loaded into the scratchpad. Instead, it is replaced by the data in EEPROM located at the target address. If a memory location is in EPROM mode, the scratchpad is loaded with the logical AND of the data sent by the master and the data in EEPROM at the target address. Copy Scratchpad commands to write-protected or EPROM mode memory locations are allowed. This allows write-protected data in the device to be refreshed, i.e., reprogrammed with the current data.

If a memory location is copy protected, a Copy Scratchpad command to that location will be blocked, which is indicated by FFh success bytes. Copy protection is used for a higher level of security, and should only be used after all write-protected pages and their associated protection control bytes are set to their final values. Copy protection as implemented with this device does not prevent copying data from one device to another; it only blocks the execution of the copy scratchpad command with a target address of a copy-protected memory page.

## Figure 5. Memory Map

Address locations 0000h to 021Fh are nonvolatile. Address locations 0220h to 0225 are volatile.

ADDRESS RANGE	TYPE	DESCRIPTION	PROTECTION CODES (NOTES)
0000h to 001Fh	R/(W)	Data Memory Page 0	(Protection controlled by address 0200h)
0020h to 003Fh	R/(W)	Data Memory Page 1	(Protection controlled by address 0201h)
0040h to 005Fh	R/(W)	Data Memory Page 2	(Protection controlled by address 0202h)
0060h to 007Fh	R/(W)	Data Memory Page 3	(Protection controlled by address 0203h)
0080h to 009Fh	R/(W)	Data Memory Page 4	(Protection controlled by address 0204h)
00A0h to 00BFh	R/(W)	Data Memory Page 5	(Protection controlled by address 0205h)
00C0h to 00DFh	R/(W)	Data Memory Page 6	(Protection controlled by address 0206h)
00E0h to 00FFh	R/(W)	Data Memory Page 7	(Protection controlled by address 0207h)
0100h to 011Fh	R/(W)	Data Memory Page 8	(Protection controlled by address 0208h)
0120h to 013Fh	R/(W)	Data Memory Page 9	(Protection controlled by address 0209h)
0140h to 015Fh	R/(W)	Data Memory Page 10	(Protection controlled by address 020Ah)
0160h to 017Fh	R/(W)	Data Memory Page 11	(Protection controlled by address 020Bh)
0180h to 019Fh	R/(W)	Data Memory Page 12	(Protection controlled by address 020Ch)
01A0h to 01BFh	R/(W)	Data Memory Page 13	(Protection controlled by address 020Dh)
01C0h to 01DFh	R/(W)	Data Memory Page 14	(Protection controlled by address 020Eh)
01E0h to 01FFh	R/(W)	Data Memory Page 15	(Protection controlled by address 020Fh)
0200h <sup>1)</sup> to 020Fh <sup>1)</sup>	R/(W)	Protection Control Pages 0 to 15	55h: Write Protected; AAh: EPROM mode. Address 0200h is associated with memory page 0, address 0201h with page 1, etc.
0210h <sup>1)</sup>	R/(W)	Register Page Lock	(See text)
0211h	R	Factory Byte	(Reads 55h or AAh)
0212h to 021Dh	N/A	Reserved	
021Eh to 021Fh	R	Factory Bytes	(Undefined value)
220h	R	PIO Logic State	(The lower two bits are valid)
221h	R	PIO Output Latch State	(The lower two bits are valid)
222h	R	PIO Activity Latch State	(The lower two bits are valid)
223h	R/W <sup>2)</sup>	Conditional Search PIO Selection Mask	
224h	R/W <sup>2)</sup>	Conditional Search Polarity Selection	
225h	R/W <sup>2)</sup>	Conditional Search Control and Status Register	

<sup>1)</sup> Once programmed to AAh or 55h this address becomes read-only. All other codes can be stored but will neither write-protect the address nor activate any function.

<sup>2)</sup> Limited write access through Write Register command

## PIO-RELATED REGISTERS

Figure 6 shows the simplified logic diagram of a PIO channel. The registers related to the PIO pins are located in the address range 0220h to 0225h. All these registers are volatile, i.e., they lose their state when the device is powered down. All PIO-related registers can be read like any data memory. There are special commands to control the PIOs for input (read), output (write), pulse-generation, and to reset the activity latches.

**Figure 6. PIO Simplified Logic Diagram**

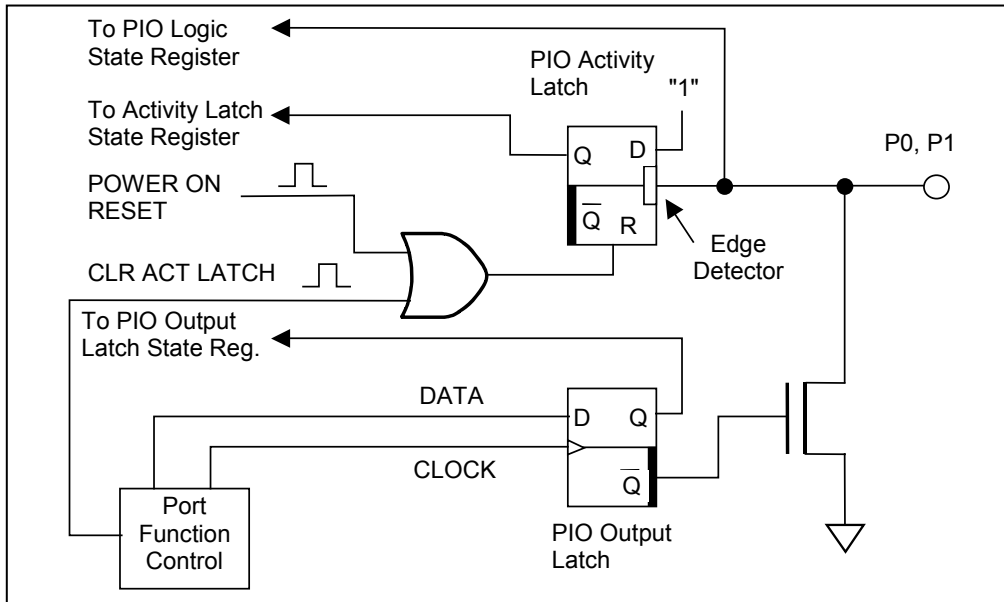

### PIO Logic State Register

ADDR	b7	b6	b5	b4	b3	b2	b1	b0
0220h	1	1	1	1	1	1	P1	P0

The logic state of the PIO pins can be obtained by reading this register using the Read Memory command. This register is read-only. Each bit is associated with the pin of the respective PIO channel. Bits 2 to 7 have no function; they always read 1. The data in this register reflects the PIO state at the last (most significant) bit of the byte that proceeds reading the first (least significant) bit of this register. See the *PIO Access Read* command description for details.

### PIO Output Latch State Register

ADDR	b7	b6	b5	b4	b3	b2	b1	b0
0221h	1	1	1	1	1	1	PL1	PL0

The data in this register represents the latest data written to the PIOs through the PIO Access Write command. This register is read using the Read Memory command. This register is not affected if the device re-initializes itself after an ESD hit. This register is read-only. Each bit is associated with the output latch of the respective PIO channel. Bits 2 to 7 have no function; they always read 1. The flip-flops of this register power up as specified by the state of the POL pin. If the chip has to power up with all PIO channels off, the POL pin must be connected to a logic "1".

### PIO Activity Latch State Register

ADDR	b7	b6	b5	b4	b3	b2	b1	b0
0222h	0	0	0	0	0	0	AL1	AL0

The data in this register represents the current state of the PIO activity latches. This register is read using the Read Memory command. This register is read-only. Each bit is associated with the activity latch of the respective PIO channel. Bits 2 to 7 have no function; they always read 0. A state transition on a PIO pin, High→Low or Low→High, of a duration greater than  $t_{PW_{MIN}}$  causes the associated bit in the register to be set to a 1. This register is cleared to 00h by a power-on reset, or by successful execution of the *Reset Activity Latches* command.

The next three registers control the device's participation a Conditional Search ROM sequence. The interaction of the various signals that determine whether the device responds to a conditional search is illustrated in Figure 7. There is a selection mask, SM, to select the participating PIOs, a polarity selection SP to specify for each channel whether the channel signal needs to be 1 or 0 to qualify, and a PLS bit to select either the activity latches or PIO pins as inputs. The signals of all channels are fed into an AND gate as well as an OR gate. The CT bit finally selects the ANDed or ORed result as the conditional search response signal CSR. If CT is 0, the channel signal of **at least one** of the selected channels must match the corresponding polarity. If CT is 1, the channel signals of **all** selected channels must match the corresponding polarity.

**Figure 7. CONDITIONAL SEARCH LOGIC**

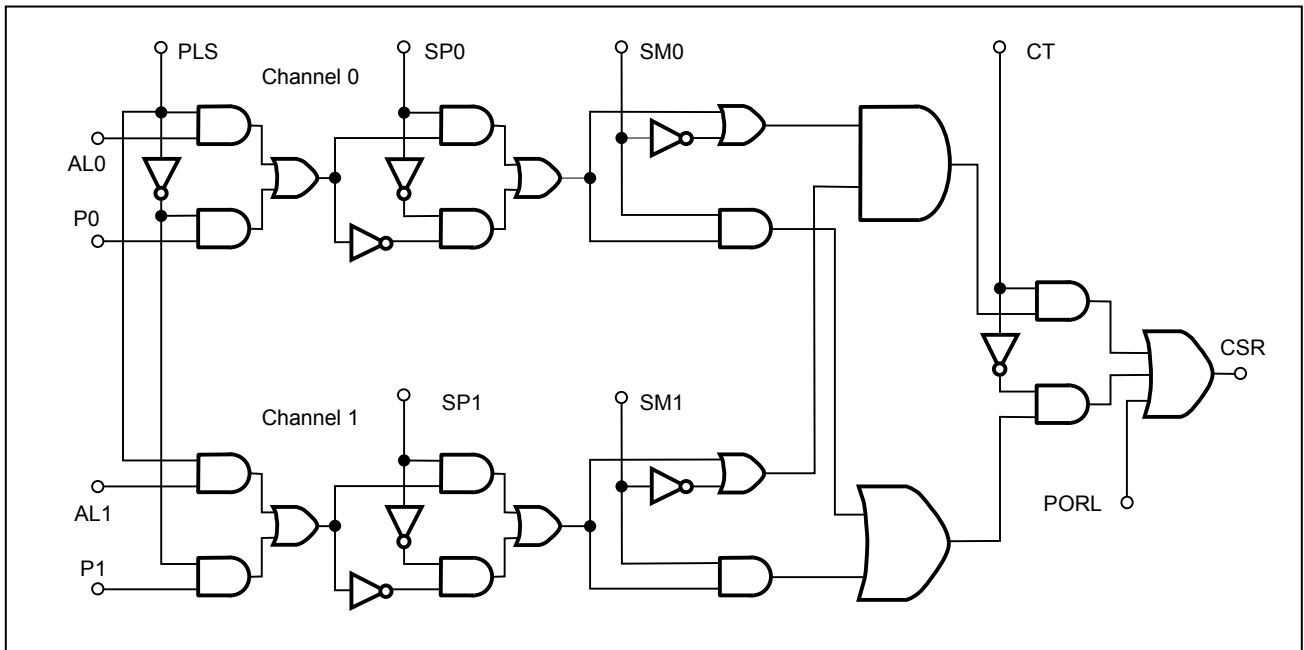

### Conditional Search Channel Selection Mask Register

ADDR	b7	b6	b5	b4	b3	b2	b1	b0
0223h	0	0	0	0	0	0	SM1	SM0

The data in this register controls whether a PIO channel qualifies for participation in the conditional search command. To include a PIO channel, the bits in this register that correspond to those channels need to be set to 1. This register can only be written through the Write Register command. This register is read/write. Each bit is associated with the respective PIO channel as shown in Figure 7. Bits 2 to 7 have no function; they always read 0 and cannot be changed to 1. This register is cleared to 00h by a power-on reset.

**Conditional Search Channel Polarity Selection Register**

ADDR	b7	b6	b5	b4	b3	b2	b1	b0
0224h	0	0	0	0	0	0	SP1	SP0

The data in this register specifies the polarity of each selected PIO channel for the device to respond to the conditional search command. This register can only be written through the Write Registers command. Within a PIO channel, the data source may be either the channel's input pin or the channel's activity latch, as specified by the PLS bit in the Control/Status register at address 0225h. This register is read/write. Each bit is associated with the respective PIO channel as shown in Figure 7. Bits 2 to 7 have no function; they always read 0 and cannot be changed to 1. This register is cleared to 00h at power-up.

**Control/Status Register**

ADDR	b7	b6	b5	b4	b3	b2	b1	b0
0225h	VCCP	POL	0	0	PORL	0	CT	PLS

The data in this register reports status information and further configures the device for conditional search. This register can only be written through the Write Registers command. This register is read/write. The power-up state of the PORL bit is "1". CT and PLS power up as "0". The functional assignments of the individual bits are explained in the table below. Bits 2, 4, and 5 have no function; they always read 0 and cannot be set to 1.

**Control/Status Register Details**

BIT DESCRIPTION	BIT(S)	DEFINITION
PLS: Pin or Activity Latch Select	b0	Selects either the PIO pins or the PIO activity latches as input for the conditional search. 0: pin selected (default) 1: activity latch selected
CT: Conditional Search Logical Term	b1	Specifies whether the data of two channels needs to be ORed or AND'ed to meet the qualifying condition for the device to respond to a conditional search. If only a single channel is selected in the channel selection mask (0223h) this bit is a don't care. 0: bitwise OR (default) 1: bitwise AND
PORL: Power-On Reset Latch	b3	Specifies whether the device has performed a power-on reset. This bit can only be cleared to 0 by writing to the Control/Status Register. As long as this bit is 1 the device will always respond to a Conditional Search ROM sequence.
POL: PIO Default Polarity (Read-Only)	b6	Reports the state of the POL pin. The state of the POL pin specifies whether the PIO pins P0 and P1 power up high or low. The polarity of a pulse generated at a PIO pin is the opposite of the pin's power-up state. 0: PIO powers up 0 1: PIO powers up 1
VCCP: V <sub>CC</sub> Power Status (Read-Only)	b7	For V <sub>CC</sub> -powered operation, the V <sub>CC</sub> pin needs to be connected to a voltage source equal to V <sub>PUP</sub> . 0: V <sub>CC</sub> power not available 1: V <sub>CC</sub> -powered operation

## ADDRESS REGISTERS AND TRANSFER STATUS

The DS28E04-100 employs three address registers, called TA1, TA2, and E/S (Figure 8). Registers TA1 and TA2 must be loaded with the target address to which the data will be written or from which data is read. Register E/S is a read-only transfer-status register, used to verify data integrity of write commands. The lower five bits of the E/S register indicate the Ending Offset within the 32-byte scratchpad. Bit 5 of the E/S register, called PF, is set if the number of data bits sent by the master is not an integer multiple of 8 or if the data in the scratchpad is not valid due to a loss of power. A valid write to the scratchpad clears the PF bit. Bit 6 has no function; it always reads 0. Note that the lowest five bits of the target address also determine the address within the scratchpad, where intermediate storage of data will begin. This address is called byte offset. If the target address (TA1) for a Write command is 03CH for example, then the scratchpad stores incoming data beginning at the byte offset 1CH and is full after only four bytes. The corresponding ending offset in this example is 1FH. For maximum data bandwidth, the target address for writing should point to the beginning of a new page, i.e., the byte offset is 0. Thus the full 32-byte capacity of the scratchpad is available, resulting also in the ending offset of 1FH. However, it is possible to write one or several contiguous bytes somewhere within a page. The ending offset together with the partial flag support the master checking the data integrity after a Write command. The highest valued bit of the E/S register, called AA is valid only if the PF flag reads 0. If PF is 0 and AA is 1, a copy has taken place. Writing data to the scratchpad clears the AA flag.

**Figure 8. Address Registers**

Bit #	7	6	5	4	3	2	1	0
Target Address (TA1)	T7	T6	T5	T4	T3	T2	T1	T0
Target Address (TA2)	T15	T14	T13	T12	T11	T10	T9	T8
Ending Address with Data Status (E/S) (Read Only)	AA	0	PF	E4	E3	E2	E1	E0

## WRITING WITH VERIFICATION

To write data to the DS28E04-100 EEPROM sections, the scratchpad has to be used as intermediate storage. First the master issues the Write Scratchpad command to specify the desired target address, followed by the data to be written to the scratchpad. Under certain conditions (see Write Scratchpad command) the master will receive an inverted CRC16 of the command, address (actual address sent), and data (as sent by the master) at the end of the Write Scratchpad command sequence. Knowing this CRC value, the master can compare it to the value it has calculated to decide whether the communication was successful and proceed to the Copy Scratchpad command. If the master could not receive the CRC16, it should use the Read Scratchpad command to verify data integrity. As a preamble to the scratchpad data, the DS28E04-100 repeats the target address TA1 and TA2 and sends the contents of the E/S register. If the PF flag is set, data did not arrive correctly in the scratchpad or there was a loss of power since data was last written to the scratchpad. The master does not need to continue reading; it can start a new trial to write data to the scratchpad. Similarly, a set AA flag together with a cleared PF flag indicates that the device did not recognize the Write command. If everything went correctly, both flags are cleared and the ending offset indicates the address of the last byte written to the scratchpad. Now the master can continue reading and verifying every data byte. After the master has verified the data, it can send the Copy Scratchpad command. This command must be followed exactly by the data of the three address registers, TA1, TA2, and E/S. The master should obtain the contents of these registers by reading the scratchpad.

## MEMORY/CONTROL FUNCTION COMMANDS

The *Memory/Control Function Flow Chart* (Figure 9) describes the protocols necessary to access the memory and the PIO pins of the DS28E04-100. Examples on how to use these functions are included at the end of this document. The communication between master and DS28E04-100 takes place either at standard speed (default, OD = 0) or at Overdrive speed (OD = 1). If not explicitly set into the Overdrive Mode, the DS28E04-100 powers up in standard speed.

### WRITE SCRATCHPAD COMMAND [0Fh]

The Write Scratchpad command applies to the data memory, and the writeable addresses in the register page. After issuing the Write Scratchpad command, the master must first provide the 2-byte target address, followed by the data to be written to the scratchpad. The data is written to the scratchpad starting at the byte offset of T4:T0. The ending offset (E4:E0) is the byte offset at which the master stops writing data. Only full data bytes are accepted. If the last data byte is incomplete, its content will be ignored and the partial byte flag PF will be set.

When executing the Write Scratchpad command, the CRC generator inside the DS28E04-100 (Figure 18) calculates a CRC of the entire data stream, starting at the command code and ending at the last data byte as sent by the master. This CRC is generated using the CRC16 polynomial by first clearing the CRC generator and then shifting in the command code (0FH) of the Write Scratchpad command, the Target Addresses (TA1 and TA2) as supplied by the master, and all the data bytes. The master may end the Write Scratchpad command at any time. However, if the end of the scratchpad is reached (E4:E0 = 1111b), the master can send 16 read-time slots and receive the CRC generated by the DS28E04-100.

If a Write Scratchpad is attempted to a write-protected location, the scratchpad is loaded with the data already in memory, rather than the data transmitted. Similarly, if the target address page is in EPROM mode, the scratchpad is loaded with the bitwise logical AND of the transmitted data and data already in memory.

### READ SCRATCHPAD COMMAND [AAh]

The Read Scratchpad command allows verification of the target address and the scratchpad data. After issuing the command code, the master begins reading. The first two bytes are the target address. The next byte is the ending offset/data status byte (E/S) followed by the scratchpad data, which may be different from what the master originally sent. This is of particular importance if the target address is within the register page or a page in either Write-Protected or EPROM modes. See the Write Scratchpad description for details. The master should read E4:E0-T4:T0+1 bytes, after which it receives the inverted CRC16, based on data as it was sent by the DS28E04-100. If the master continues reading after the CRC, all data will be logic 1s.

### COPY SCRATCHPAD [55h]

The Copy Scratchpad command is used to copy data from the scratchpad to the data memory and the writable sections of the Register Page. After issuing the Copy Scratchpad command, the master must provide a 3-byte authorization pattern, which should have been obtained by an immediately preceding Read Scratchpad command. This 3-byte pattern must exactly match the data contained in the three address registers (TA1, TA2, E/S, in that order). If the pattern matches, the target address is valid, the PF flag is not set, and the target memory is not copy-protected, the AA (Authorization Accepted) flag is set and the copy begins. The data to be copied is determined by the three address registers. The scratchpad data from the beginning offset through the ending offset will be copied to memory, starting at the target address. Anywhere from 1 to 32 bytes can be copied with this command. The device's internal data transfer takes 10ms maximum during which the voltage on the 1-Wire bus must not fall below 2.8V. After waiting 10ms, the master may issue read time slots to receive AAh confirmation bytes until the master issues a reset pulse. If the PF flag is set or the target memory is copy-protected, the copy will not begin and the AA flag will not be set.

**Figure 9-1. Memory/Control Function Flow Chart**

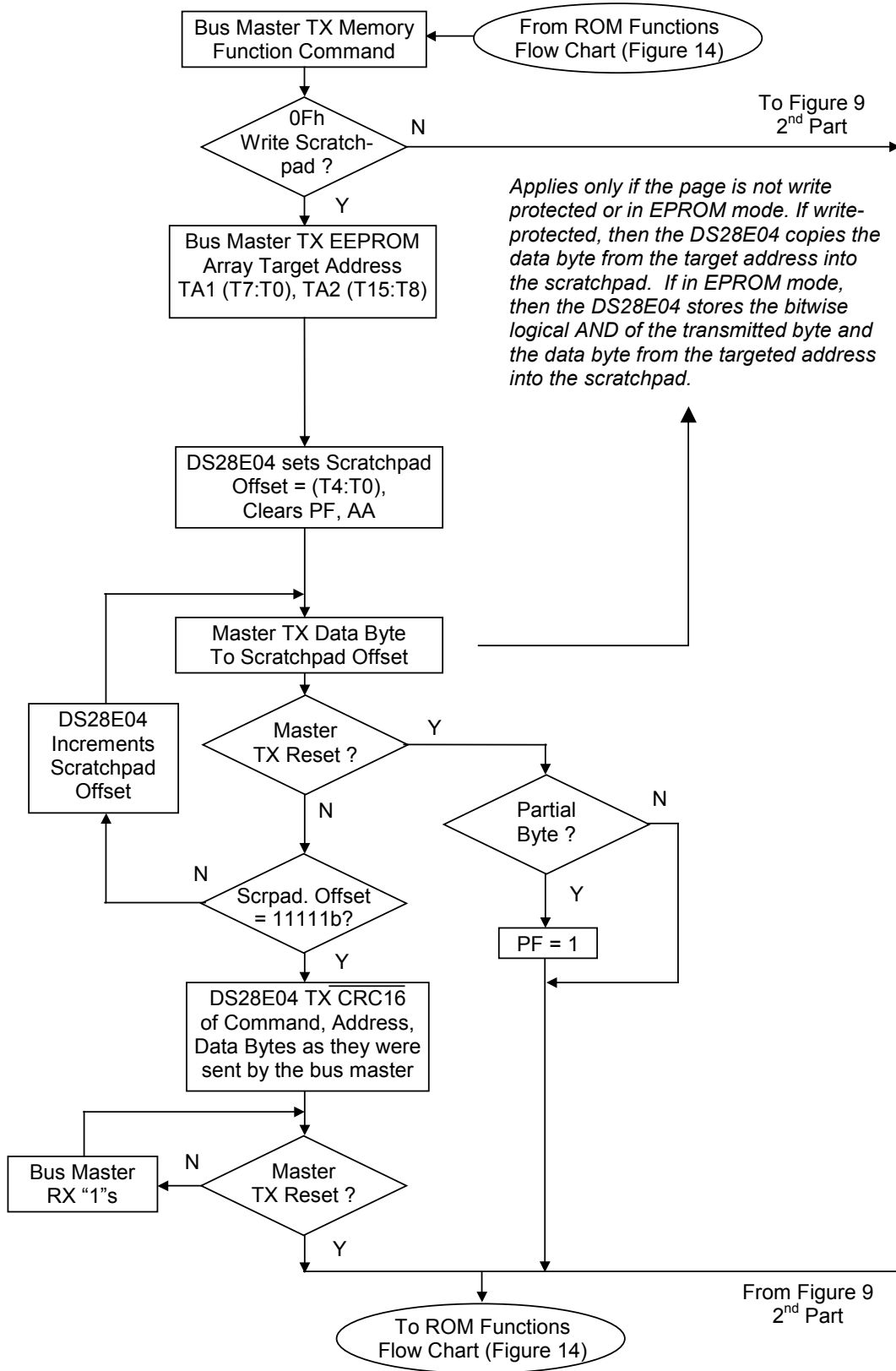

Figure 9-2. Memory/Control Function Flow Chart (continued)

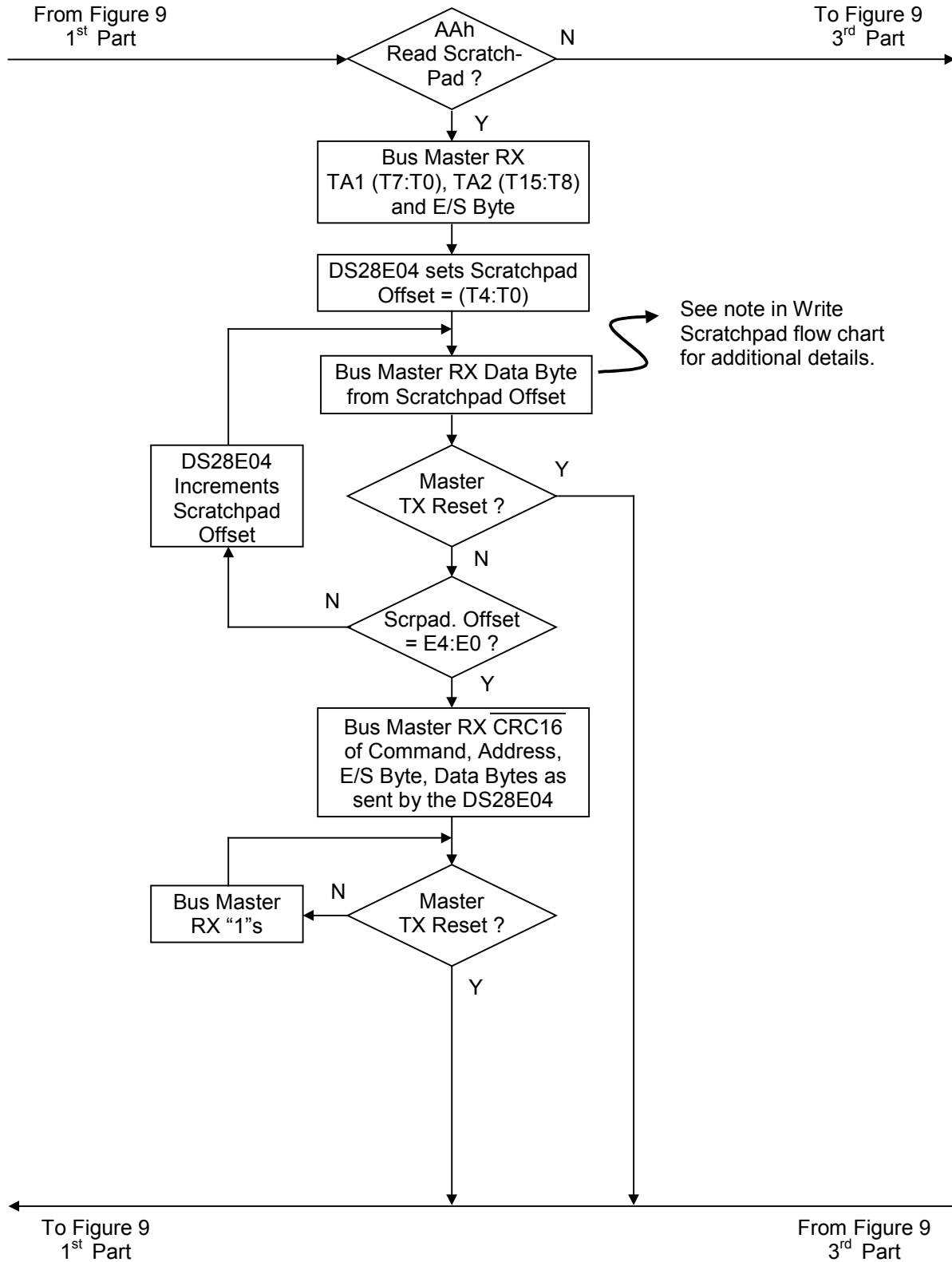

Figure 9-3. Memory/Control Function Flow Chart (continued)

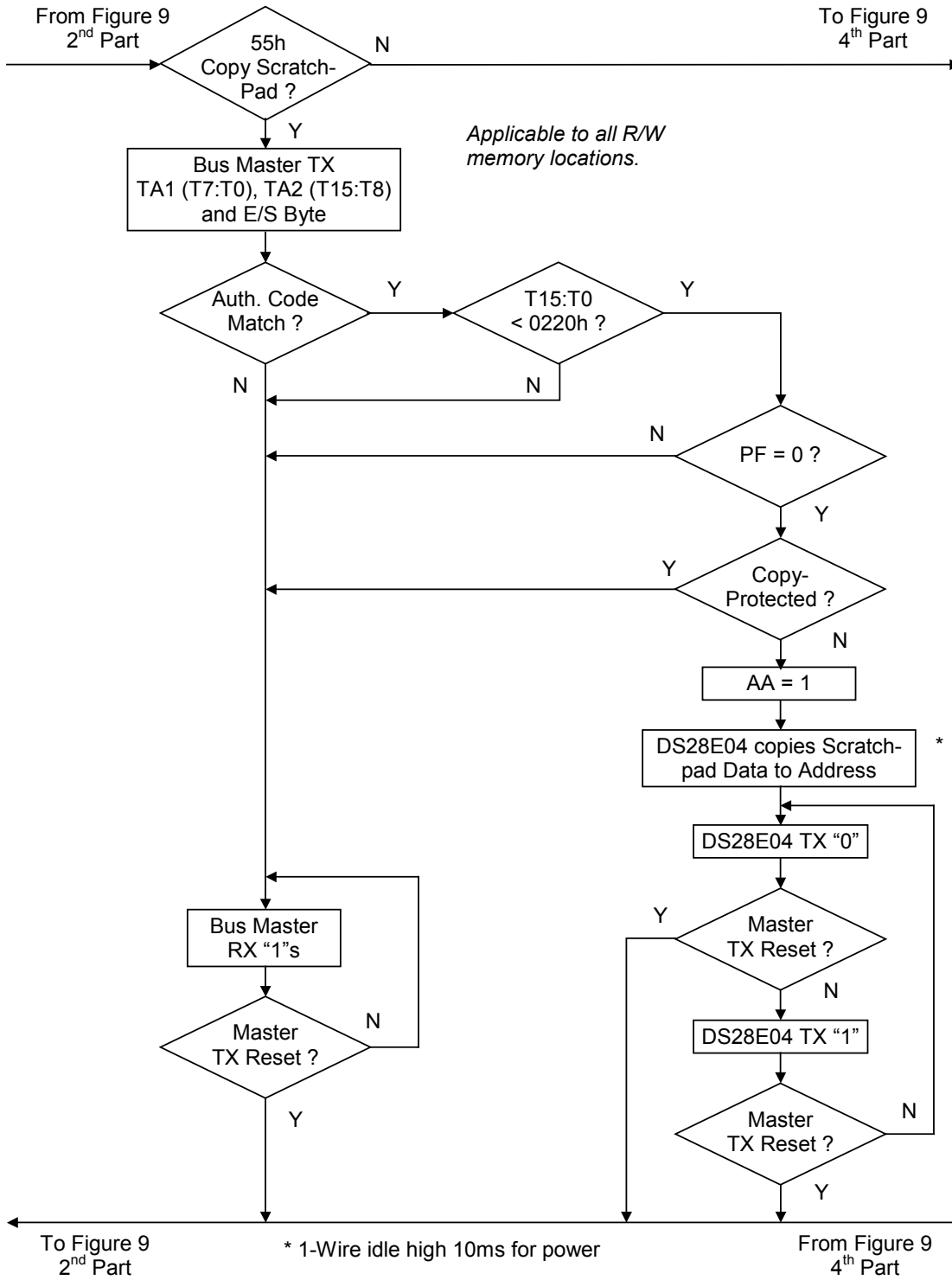

Figure 9-4. Memory/Control Function Flow Chart (continued)

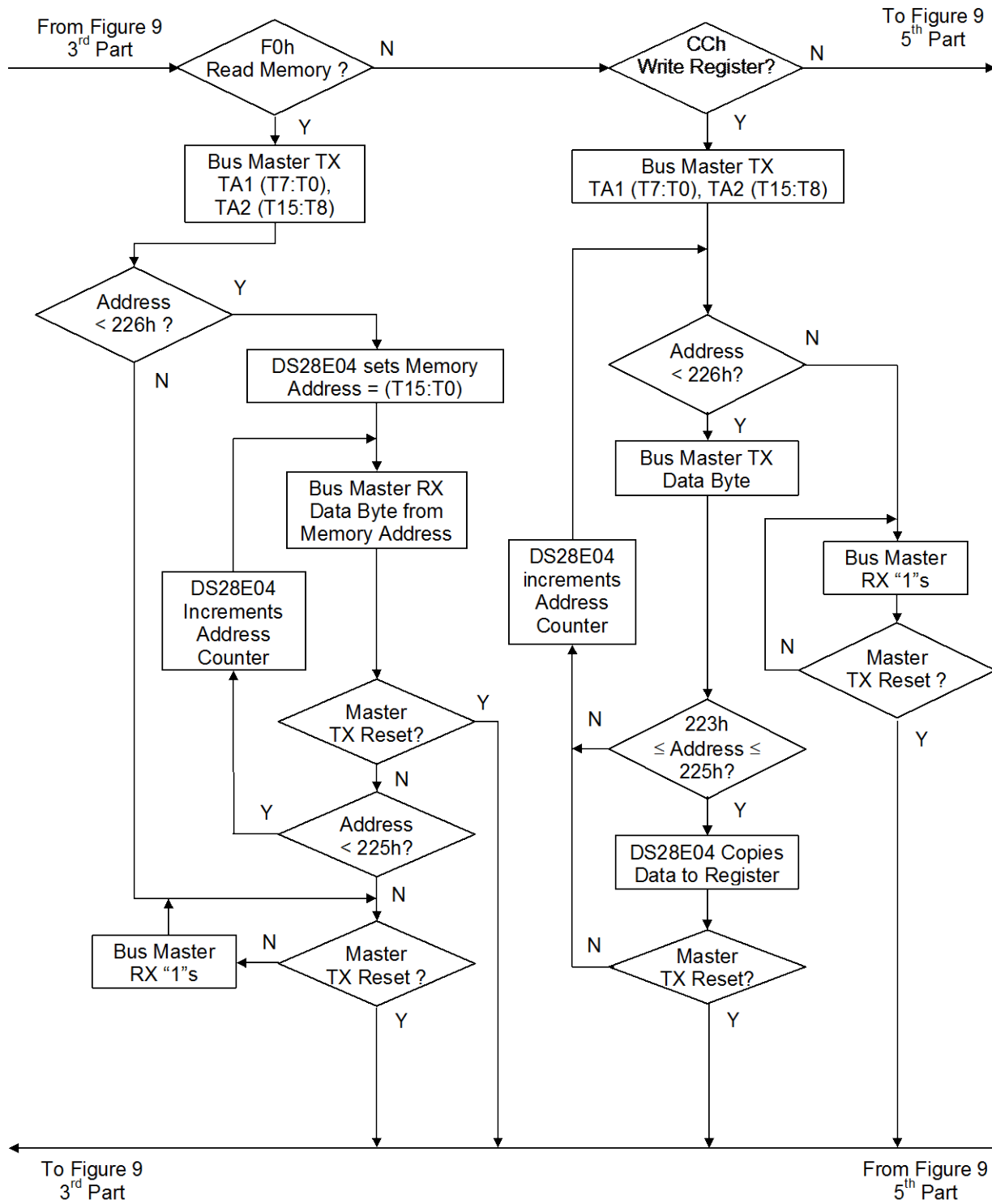

Figure 9-5. Memory/Control Function Flow Chart (continued)

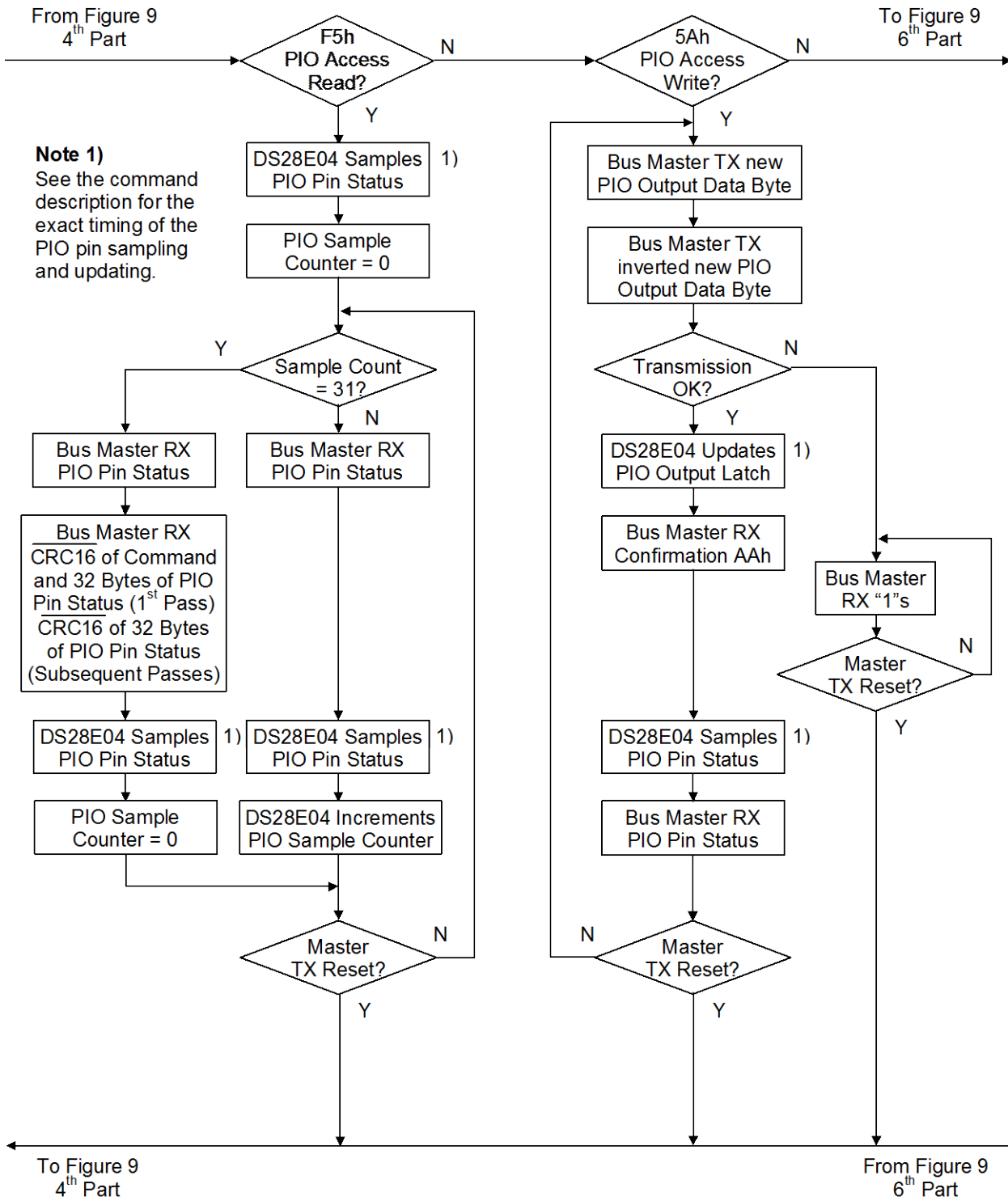
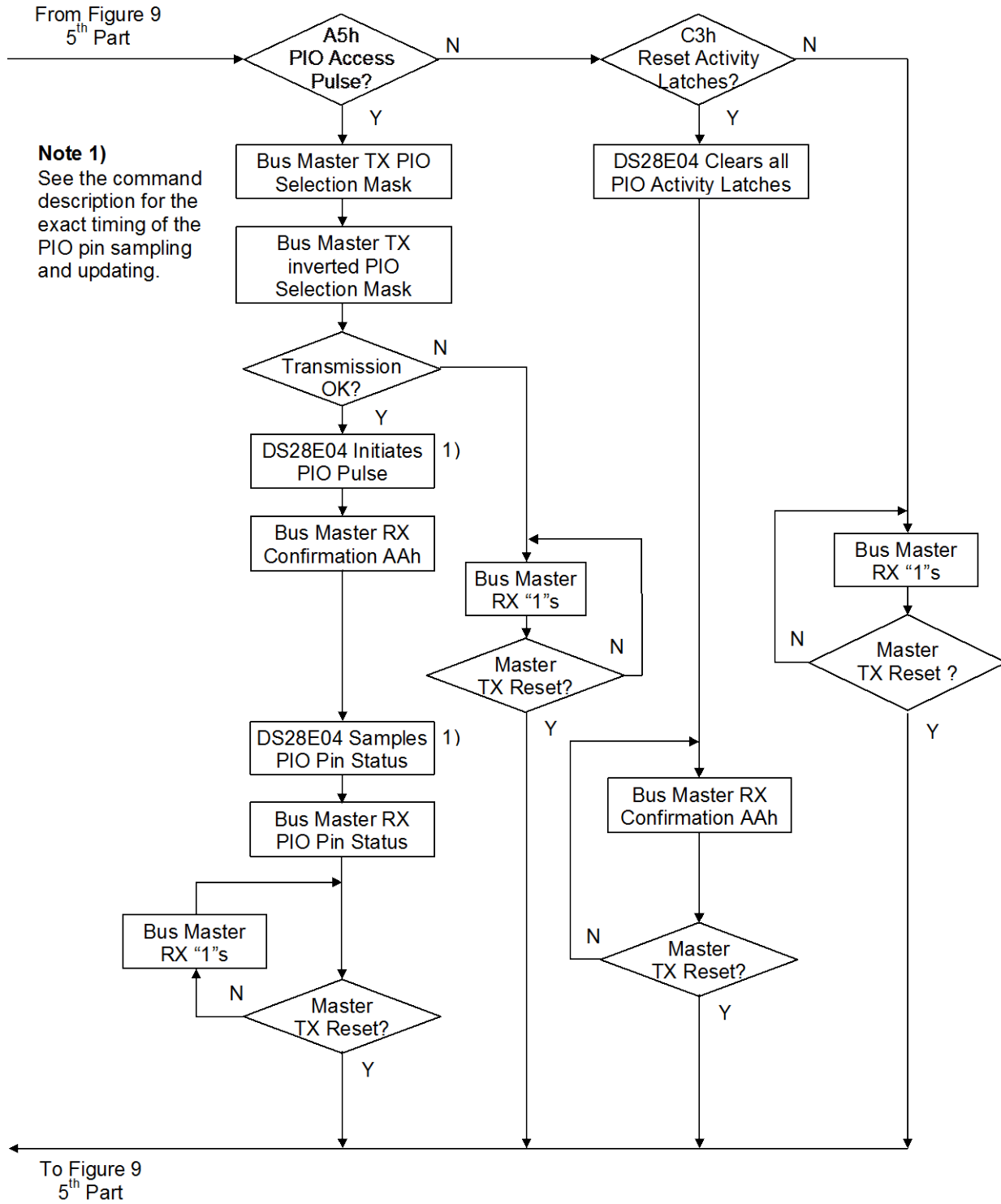

Figure 9-6. Memory/Control Function Flow Chart (continued)



## READ MEMORY [F0h]

The Read Memory command is the general function to read data from the DS28E04-100. After issuing the command, the master must provide a 2-byte target address in the range of 0000h to 0225h. After these two bytes, the master reads data beginning from the target address and may continue until address 0225h. If the master continues reading, the result will be logic 1s. The device's internal TA1, TA2, E/S, and scratchpad contents are not affected by a Read Memory command.

The hardware of the DS28E04-100 provides a means to accomplish error-free writing to the memory section. To safeguard reading data in the 1-Wire environment and to simultaneously speed up data transfers, it is recommended to packetize data into data packets the size of one memory page each. Such a packet would typically store a 16-bit CRC with each page of data to insure rapid, error-free data transfers that eliminate having to read a page multiple times to determine if the received data is correct or not. (See *Application Note 114* for the recommended file structure.)

## WRITE REGISTER [CCh]

The conditional search settings and the status/control register are volatile. They need to be loaded after every power-up cycle with the Write Register command. After issuing the command, the master sends the 2-byte target address, which should be a value between 0223h and 0225h. Next the master sends the byte to be written to the addressed cell. If the address was valid, the byte is immediately written to its memory location. The master now can either end the command by issuing a 1-Wire reset or send another byte for the next higher address. Once memory address 0225h has been written, any subsequent data bytes will be ignored. The master has to send a 1-Wire reset to end the command. Since the Write Register flow does not include any error-checking for the new register data, it is important to verify correct writing by reading the registers using the Read Memory command.

## PIO ACCESS READ [F5h]

In contrast to reading the PIO logical state from address 0220h, this command reads the PIO logical status in an endless loop. After 32 bytes of PIO pin status the DS28E04-100 inserts an inverted CRC16 into the data stream, which allows the master to verify whether the data was received error-free. A PIO Access Read can be terminated at any time with a 1-Wire Reset. The state of the POL pin does not affect this command.

The status of both PIO channels is sampled at the same time. The first sampling occurs during the last (most significant) bit of the command code F5h. The first (least significant) bit of the PIO status byte is associated to P0, and the next bit to P1. The other 6 bits of a PIO status byte do not have corresponding PIO pins; they always read "1". While the master receives the last bit of the PIO status byte, the next sampling occurs and so on until the master has received 32 PIO samples. Next the master receives the inverted CRC16 of the command byte and 32 PIO samples (first pass) or the CRC of 32 PIO samples (subsequent passes). While the last (most significant) bit of the CRC is transmitted, the next PIO sampling takes place. The sampling occurs with a delay of  $t_{REH} + x$  from the rising edge of the MS bit of the previous byte, as shown in Figure 10. The value of "x" is approximately 0.2 $\mu$ s.

**Figure 10. PIO Access Read Timing Diagram**

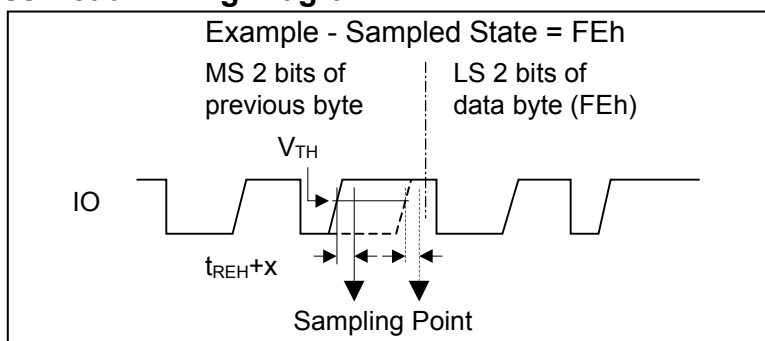

### Notes:

- 1 The "previous byte" could be the command code, the data byte resulting from the previous PIO sample, or the MS byte of a CRC16.
- 2 The sample point timing also applies to the PIO Access Write and Pulse command, with the "previous byte" being the write confirmation byte (AAh).

## PIO ACCESS WRITE [5Ah]

The PIO Access Write command is the only way to write to the PIO output-latch state register (address 0221h), which controls the open-drain output transistors of the PIO channels. In an endless loop, this command first writes new data to the PIO and then reads back the PIO status. The implicit read-after-write can be used by the master for status verification. A PIO Access Write can be terminated at any time with a 1-Wire Reset. The state of the POL pin does not affect this command.

After the command code, the master transmits a byte that determines the new state of the PIO output transistors. The first (least significant) bit is associated to P0; the next bit affects P1. The other 6 bits of the new state byte do not have corresponding PIO pins. These bits should always be transmitted as "1"s. To switch the output transistor off (nonconducting) the corresponding bit value is 1. To switch the transistor on, that bit needs to be 0. This way the data byte transmitted as the new PIO output state arrives in its true form at the PIO pins. To protect the transmission against data errors, the master must repeat the new PIO byte in its inverted form. Only if the transmission was error-free does the PIO status change. The actual PIO transition to the new state occurs with a delay of  $t_{REH} + x$  from the rising edge of the MS bit of the inverted PIO byte, as shown in Figure 11. The value of "x" is approximately  $0.2\mu\text{s}$ . To inform the master about the successful change of the PIO status, the DS28E04-100 transmits a confirmation byte with the data pattern AAh. After the MS bit of the confirmation byte is transmitted, the DS28E04-100 samples the status of the PIO pins, as shown in Figure 10, and sends it to the master. Depending on the data the master can either continue writing more data to the PIO or issue a 1-Wire reset to end the command.

**Figure 11. PIO Access Write Timing Diagram**

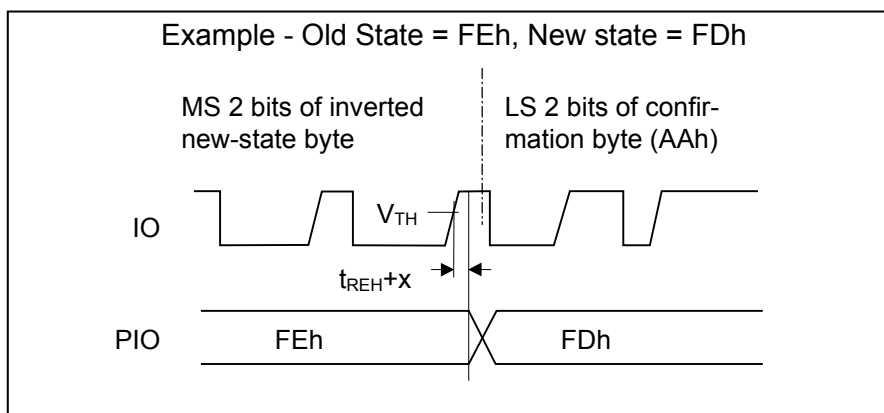

## PIO ACCESS PULSE [A5h]

As a convenient alternative to using PIO Access Write, the PIO Access Pulse command generates a self-timed pulse on the selected PIO outputs. The polarity of the pulse is determined by the state of the POL pin. If POL = 1, the pulse is negative (active low) and vice versa. The PIO Access Pulse command is accepted only if the device is  $V_{CC}$  powered.

After the command code the master transmits a selection mask that specifies the PIO at which the pulse is to be generated. A PIO is selected if the corresponding bit in the selection mask is a "1". The first (least significant) bit is associated to P0; the next bit affects P1. The other 6 bits of the selection mask do not have corresponding PIO pins. These bits should always be transmitted as "1"s. To protect the transmission against data errors, the master must repeat the selection mask in its inverted form. Only if the transmission was error-free does the pulse occur. The pulse begins with a delay of  $t_{REH} + x$  from the rising edge of the MS bit of the inverted selection mask, as shown in Figure 12. The value of "x" is approximately  $0.2\mu\text{s}$ . To inform the master about the successful pulse generation, the DS28E04-100 transmits a confirmation byte with the data pattern AAh. While the last bit of the confirmation byte is transmitted, the DS28E04-100 samples the status of the PIO pins, as shown in Figure 10, and sends it to the master. Now the master can issue a 1-Wire reset to exit the command flow. This does not terminate the pulse on a PIO pin.

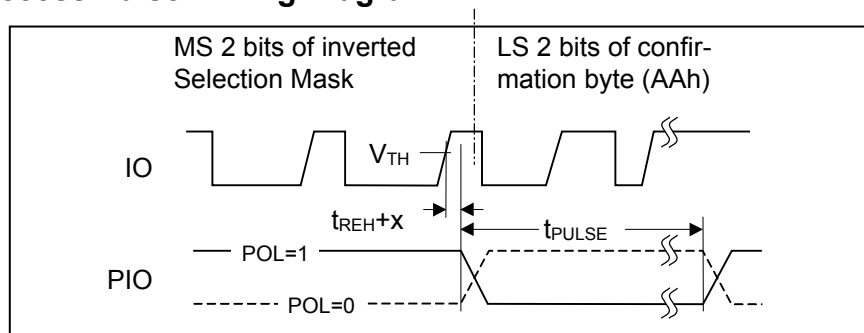
**Figure 12. PIO Access Pulse Timing Diagram**

## RESET ACTIVITY LATCHES [C3h]

Each PIO channel includes an activity latch that is set whenever there is a state transition at a PIO pin of duration greater than  $t_{PWMIN}$ . This change can be caused by an external event/signal or by writing to the PIO or by generating a pulse. Depending on the application there may be a need to reset the activity latch after having captured and serviced an external event. Since there is only read access to the PIO Activity Latch State Register, the DS28E04-100 supports a special command to reset these latches. After having received the command code, the device resets all activity latches simultaneously. There are two ways for the master to verify the execution of the Reset Activity Latches command. One way is to start reading from the 1-Wire line right after the command code is transmitted. In this case, the master reads AAh bytes until it sends a 1-Wire reset. The other way is reading register address 0222h.

## 1-Wire BUS SYSTEM

The 1-Wire bus is a system that has a single bus master and one or more slaves. In all instances the DS28E04-100 is a slave device. The bus master is typically a microcontroller. The discussion of this bus system is broken down into three topics: hardware configuration, transaction sequence, and 1-Wire signaling (signal types and timing). The 1-Wire protocol defines bus transactions in terms of the bus state during specific time slots, which are initiated on the falling edge of sync pulses from the bus master.

## HARDWARE CONFIGURATION

The 1-Wire bus has only a single line by definition; it is important that each device on the bus be able to drive it at the appropriate time. To facilitate this, each device attached to the 1-Wire bus must have open-drain or tri-state outputs. The 1-Wire port of the DS28E04-100 is open drain with an internal circuit equivalent to that shown in Figure 13.

A multidrop bus consists of a 1-Wire bus with multiple slaves attached. The DS28E04-100 supports both a standard and Overdrive communication speed of 15.4kbps (max) and 111kbps (max), respectively. Note that legacy 1-Wire products support a standard communication speed of 16.3kbps and Overdrive of 142kbps. The slightly reduced rates for the DS28E04-100 are a result of additional recovery times, which in turn were driven by a 1-Wire physical interface enhancement to improve noise immunity. The value of the pullup resistor primarily depends on the network size and load conditions. The DS28E04-100 requires a pullup resistor of 2.2k $\Omega$  (max) at any speed.

The idle state for the 1-Wire bus is high. If, for any reason, a transaction needs to be suspended, the bus MUST be left in the idle state if the transaction is to resume. If this does not occur and the bus is left low for more than 16 $\mu$ s (Overdrive speed) or more than 120 $\mu$ s (standard speed), one or more devices on the bus can be reset.

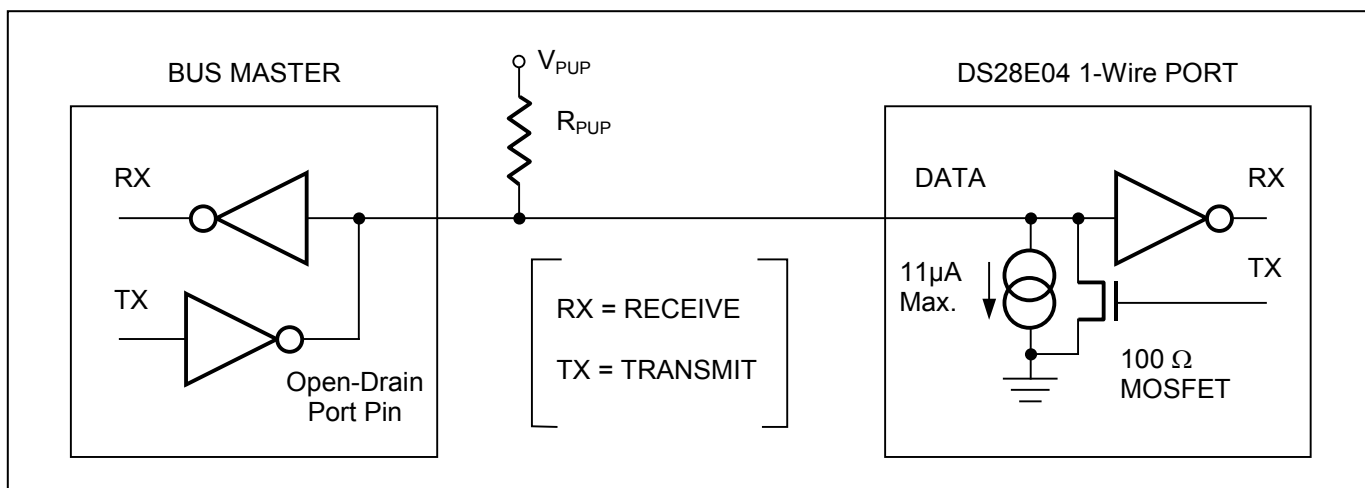
**Figure 13. Hardware Configuration**

## TRANSACTION SEQUENCE

The protocol for accessing the DS28E04-100 through the 1-Wire port is as follows:

- Initialization
- ROM Function Command
- Memory/Control Function Command
- Transaction/Data

## INITIALIZATION

All transactions on the 1-Wire bus begin with an initialization sequence. The initialization sequence consists of a reset pulse transmitted by the bus master followed by presence pulse(s) transmitted by the slave(s). The presence pulse lets the bus master know that the DS28E04-100 is on the bus and is ready to operate. For more details, see the *1-Wire Signaling* section.

## 1-Wire ROM FUNCTION COMMANDS

Once the bus master has detected a presence, it can issue one of the eight ROM function commands that the DS28E04-100 supports. All ROM function commands are 8 bits long. A list of these commands follows (refer to the flow chart in Figure 14).

### READ ROM [33h]

This command allows the bus master to read the DS28E04-100's 8-bit family code, unique 40-bit serial number, 8-bit address byte, and 8-bit CRC. The lower order 7 bits of the address byte read back the state of the address pins A6 to A0. See also Figure 3. This command can only be used if there is a single slave on the bus. If more than one slave is present on the bus, a data collision occurs when all slaves try to transmit at the same time (open drain produces a wired-AND result). The resultant family code and 48-bit serial number result in a mismatch of the CRC. Note that there will also be a CRC mismatch if one or more of the external address inputs are connected to GND. The ROM CRC is hardcoded with A6 to A0 set to 1s. The master should comprehend this and calculate the ROM CRC similarly.

### MATCH ROM [55h]

The Match ROM command, followed by a 64-bit ROM sequence, allows the bus master to address a specific DS28E04-100 on a multidrop bus. Only the DS28E04-100 that exactly matches the 64-bit ROM sequence, including the external address, responds to the following Memory/Control Function command. All other slaves wait for a reset pulse. This command can be used with a single or multiple devices on the bus.

## SEARCH ROM [F0h]

When a system is initially brought up, the bus master might not know the number of devices on the 1-Wire bus or their device ID numbers. By taking advantage of the wired-AND property of the bus, the master can use a process of elimination to identify the device ID numbers of all slave devices. For each bit of the device ID number, starting with the least significant bit, the bus master issues a triplet of time slots. On the first slot, each slave device participating in the search outputs the true value of its device ID number bit. On the second slot, each slave device participating in the search outputs the complemented value of its device ID number bit. On the third slot, the master writes the true value of the bit to be selected. All slave devices that do not match the bit written by the master stop participating in the search. If both of the read bits are zero, the master knows that slave devices exist with both states of the bit. By choosing which state to write, the bus master branches in the romcode tree. After one complete pass, the bus master knows the device ID number of a single device. Additional passes identify the device ID numbers of the remaining devices. Refer to *Application Note 187: 1-Wire Search Algorithm* for a detailed discussion, including an example.

**Note:** Since the DS28E04-100 lasered ROM CRC is calculated assuming the address inputs are all logic 1, then any address inputs that are connected to GND are not validated. It is recommended to do a double search when building a list of devices on the 1-Wire line.

## CONDITIONAL SEARCH [ECh]

The Conditional Search ROM command operates similarly to the Search ROM command except that only those devices, which fulfill certain conditions (CSR = 1), will participate in the search. This function provides an efficient means for the bus master to identify devices on a multidrop system that have to signal an important event. After each pass of the conditional search that successfully determined the 64-bit ROM code for a specific device on the multidrop bus, that particular device can be individually accessed as if a Match ROM had been issued, since all other devices will have dropped out of the search process and will be waiting for a reset pulse. The DS28E04-100 responds to the conditional search if the CSR signal is active. See the description of the registers at addresses 0223h to 0225h and Figure 7 for more details.

## SKIP ROM [CCh]

This command can save time in a single-drop bus system by allowing the bus master to access the memory functions without providing the 64-bit ROM code. If more than one slave is present on the bus and, for example, a Read command is issued following the Skip ROM command, data collision occurs on the bus as multiple slaves transmit simultaneously (open-drain pulldowns produce a wired-AND result).

## RESUME [A5h]

To maximize the data throughput in a multidrop environment, the Resume function is available. This function checks the status of the RC bit and, if it is set, directly transfers control to the Memory functions, similar to a Skip ROM command. The only way to set the RC bit is through successfully executing the Match ROM, Search ROM, or Overdrive Match ROM command. Once the RC bit is set, the device can repeatedly be accessed through the Resume Command function. Accessing another device on the bus clears the RC bit, preventing two or more devices from simultaneously responding to the Resume Command function.

## OVERDRIVE SKIP ROM [3Ch]

On a single-drop bus this command can save time by allowing the bus master to access the memory functions without providing the 64-bit ROM code. Unlike the normal Skip ROM command, the Overdrive Skip ROM sets the DS28E04-100 in the Overdrive mode (OD = 1). All communication following this command has to occur at Overdrive speed until a reset pulse of minimum 480µs duration resets all devices on the bus to standard speed (OD = 0).

When issued on a multidrop bus, this command sets all Overdrive-supporting devices into Overdrive mode. To subsequently address a specific Overdrive-supporting device, a reset pulse at Overdrive speed has to be issued followed by a Match ROM or Search ROM command sequence. This speeds up the time for the search process. If more than one slave supporting Overdrive is present on the bus and the Overdrive Skip ROM command is followed by a Read command, data collision occurs on the bus as multiple slaves transmit simultaneously (open-drain pulldowns produce a wired-AND result).

Figure 14-1. ROM Functions Flow Chart

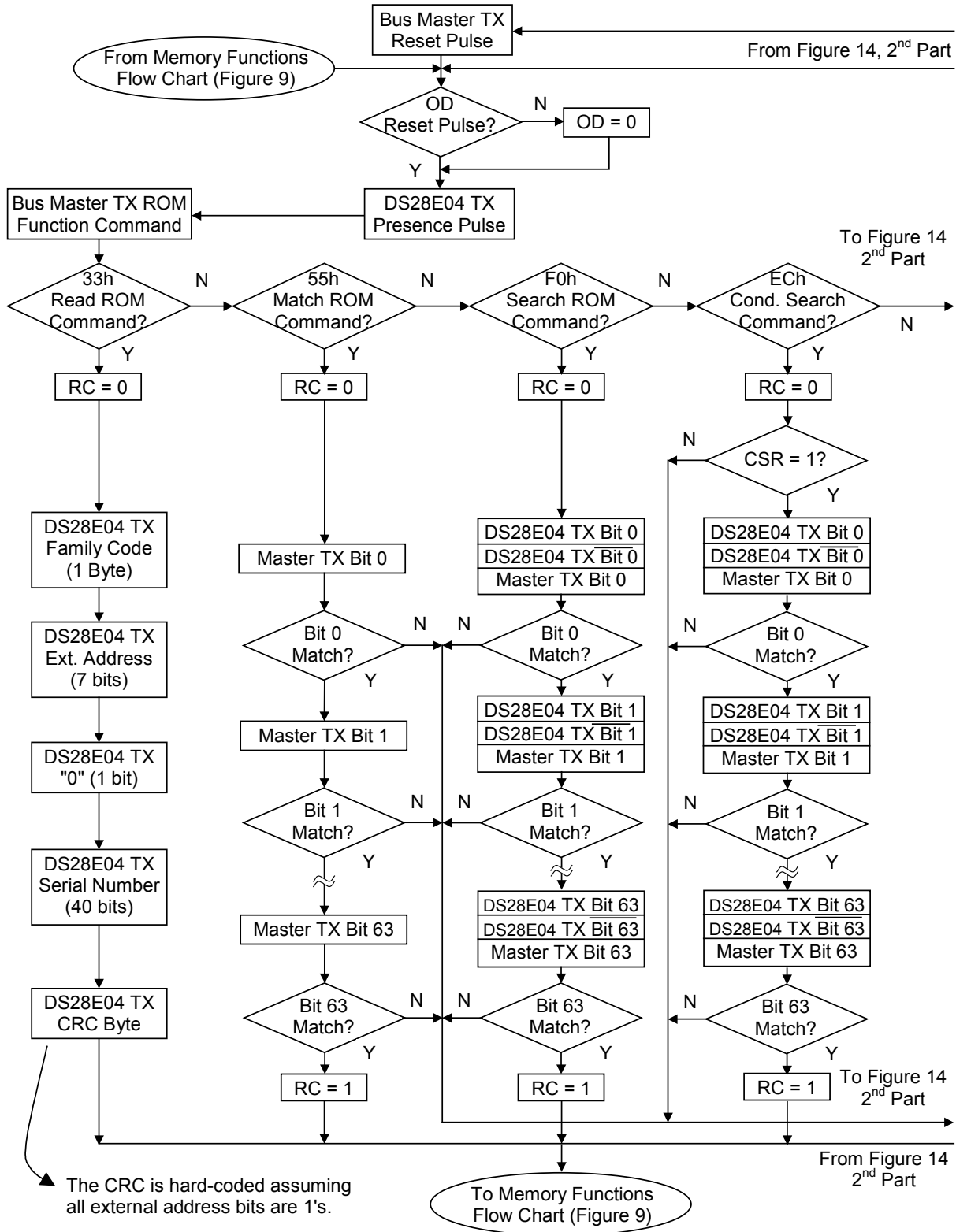
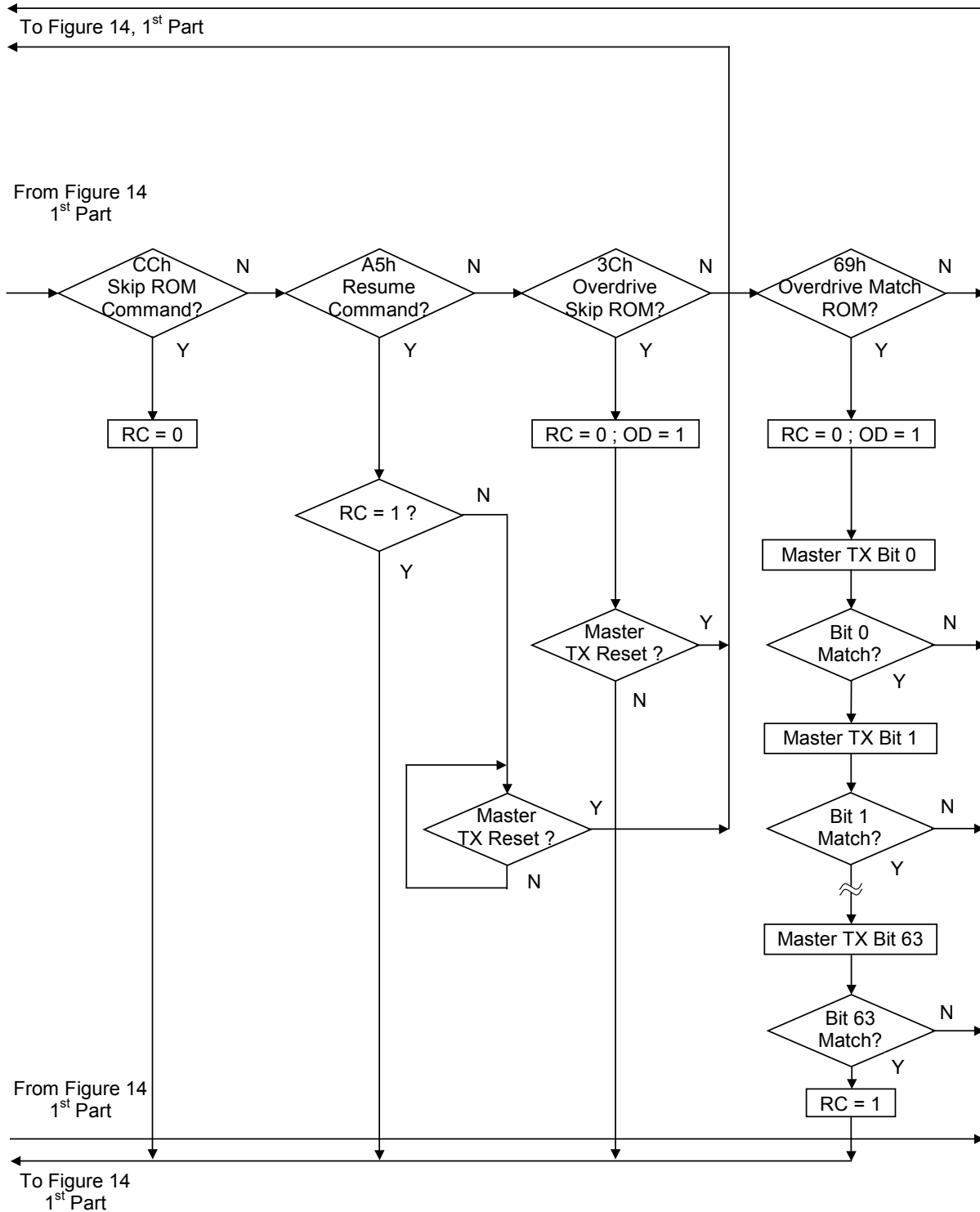

Figure 14-2. ROM Functions Flow Chart (continued)



## OVERDRIVE MATCH ROM [69h]

The Overdrive Match ROM command followed by a 64-bit ROM sequence transmitted at Overdrive speed allows the bus master to address a specific DS28E04-100 on a multidrop bus and to simultaneously set it in Overdrive mode. Only the DS28E04-100 that exactly matches the 64-bit ROM sequence responds to the subsequent Memory/Control Function command. Slaves already in Overdrive mode from a previous Overdrive Skip or successful Overdrive Match command remain in Overdrive mode. All overdrive-capable slaves return to standard speed at the next Reset Pulse of minimum 480 $\mu$ s duration. The Overdrive Match ROM command can be used with a single or multiple devices on the bus.

## 1-Wire SIGNALING

The DS28E04-100 requires strict protocols to ensure data integrity. The protocol consists of four types of signaling on one line: Reset Sequence with Reset Pulse and Presence Pulse, Write-Zero, Write-One, and Read-Data. Except for the Presence pulse, the bus master initiates all falling edges. The DS28E04-100 can communicate at two different speeds, standard speed, and Overdrive speed. If not explicitly set into the Overdrive mode, the DS28E04-100 communicates at standard speed. While in Overdrive Mode, the fast timing applies to all waveforms.

To get from idle to active, the voltage on the 1-Wire line needs to fall from  $V_{PUP}$  below the threshold  $V_{TL}$ . To get from active to idle, the voltage needs to rise from  $V_{ILMAX}$  past the threshold  $V_{TH}$ . The time it takes for the voltage to make this rise is seen in Figure 15 as ' $\epsilon$ ' and its duration depends on the pullup resistor ( $R_{PUP}$ ) used and the capacitance of the 1-Wire network attached. The voltage  $V_{ILMAX}$  is relevant for the DS28E04-100 when determining a logical level, not triggering any events.

Figure 15 shows the initialization sequence required to begin any communication with the DS28E04-100. A Reset Pulse followed by a Presence Pulse indicates the DS28E04-100 is ready to receive data, given the correct ROM and Memory/Control Function command. If the bus master uses slew-rate control on the falling edge, it must pull down the line for  $t_{RSTL} + t_f$  to compensate for the edge. A  $t_{RSTL}$  duration of 480 $\mu$ s or longer exits the Overdrive Mode, returning the device to standard speed. If the DS28E04-100 is in Overdrive Mode and  $t_{RSTL}$  is no longer than 80 $\mu$ s, the device remains in Overdrive Mode. If the device is in Overdrive Mode and  $t_{RSTL}$  is *between* 80 $\mu$ s and 480 $\mu$ s, the device will reset, but the communication speed is undetermined.

**Figure 15. Initialization Procedure: Reset and Presence Pulse**

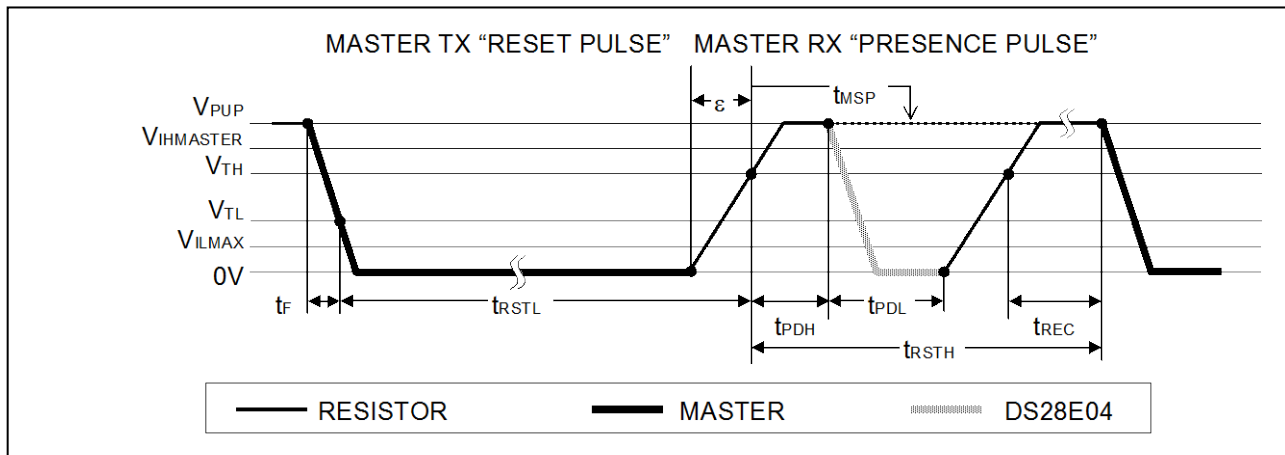

After the bus master has released the line, it goes into receive mode. Now the 1-Wire bus is pulled to  $V_{PUP}$  through the pullup resistor, or in case of a DS2482-x00 or DS2480B driver, by active circuitry. When the threshold  $V_{TH}$  is crossed, the DS28E04-100 waits for  $t_{PDH}$  and then transmits a Presence Pulse by pulling the line low for  $t_{PDL}$ . To detect a presence pulse, the master must test the logical state of the 1-Wire line at  $t_{MSP}$ .

The  $t_{RSTH}$  window must be at least the sum of  $t_{PDHMAX}$ ,  $t_{PDLMAX}$ , and  $t_{RECMIN}$ . Immediately after  $t_{RSTH}$  is expired, the DS28E04-100 is ready for data communication. In a mixed population network,  $t_{RSTH}$  should be extended to minimum 480 $\mu$ s at standard speed and 48 $\mu$ s at Overdrive speed to accommodate other 1-Wire devices.

### Read/Write Time Slots

Data communication with the DS28E04-100 takes place in time slots, which carry a single bit each. Write time slots transport data from bus master to slave. Read time slots transfer data from slave to master. Figure 16 illustrates the definitions of the write and read time slots.

All communication begins with the master pulling the data line low. As the voltage on the 1-Wire line falls below the threshold  $V_{TL}$ , the DS28E04-100 starts its internal timing generator that determines when the data line is sampled during a write time slot and how long data is valid during a read time slot.

**Figure 16. Read/Write Timing Diagram**

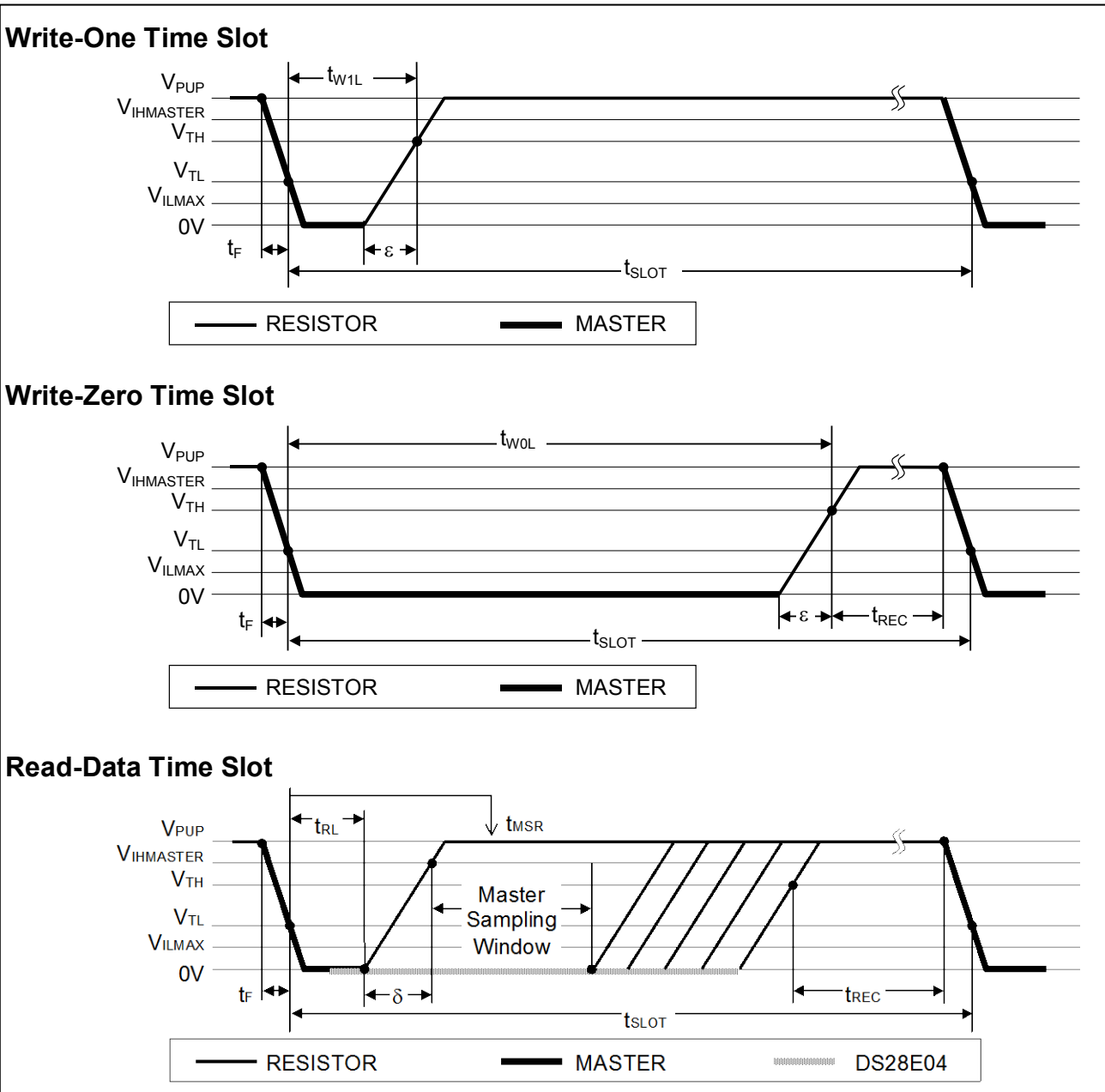

## Master-to-Slave

For a **write-one** time slot, the voltage on the data line must have crossed the  $V_{TH}$  threshold before the write-one low time  $t_{W1LMAX}$  is expired. For a **write-zero** time slot, the voltage on the data line must stay below the  $V_{TH}$  threshold until the write-zero low time  $t_{W0LMIN}$  is expired. For the most reliable communication, the voltage on the data line should not exceed  $V_{ILMAX}$  during the entire  $t_{W0L}$  or  $t_{W1L}$  window. After the  $V_{TH}$  threshold has been crossed, the DS28E04-100 needs a recovery time  $t_{REC}$  before it is ready for the next time slot.

## Slave-to-Master

A **read-data** time slot begins like a write-one time slot. The voltage on the data line must remain below  $V_{TL}$  until the read low time  $t_{RL}$  is expired. During the  $t_{RL}$  window, when responding with a 0, the DS28E04-100 starts pulling the data line low; its internal timing generator determines when this pulldown ends and the voltage starts rising again. When responding with a 1, the DS28E04-100 does not hold the data line low at all, and the voltage starts rising as soon as  $t_{RL}$  is over.

The sum of  $t_{RL} + \delta$  (rise time) on one side and the internal timing generator of the DS28E04-100 on the other side define the master sampling window ( $t_{MSRMIN}$  to  $t_{MSRMAX}$ ) in which the master must perform a read from the data line. For the most reliable communication,  $t_{RL}$  should be as short as permissible, and the master should read close to but no later than  $t_{MSRMAX}$ . After reading from the data line, the master must wait until  $t_{SLOT}$  is expired. This guarantees sufficient recovery time  $t_{REC}$  for the DS28E04-100 to get ready for the next time slot. Note that  $t_{REC}$  specified herein applies only to a single DS28E04-100 attached to a 1-Wire line. For multidevice configurations,  $t_{REC}$  needs to be extended to accommodate the additional 1-Wire device input capacitance. Alternatively, an interface that performs active pullup during the 1-Wire recovery time such as the DS2482-x00 or DS2480B 1-Wire line drivers can be used.

## IMPROVED NETWORK BEHAVIOR (SWITCHPOINT HYSTERESIS)

In a 1-Wire environment, line termination is possible only during transients controlled by the bus master (1-Wire driver). 1-Wire networks, therefore, are susceptible to noise of various origins. Depending on the physical size and topology of the network, reflections from end points and branch points can add up, or cancel each other to some extent. Such reflections are visible as glitches or ringing on the 1-Wire communication line. Noise coupled onto the 1-Wire line from external sources can also result in signal glitching. A glitch during the rising edge of a time slot can cause a slave device to lose synchronization with the master and, consequently, result in a search ROM command coming to a dead end or cause a device-specific function command to abort. For better performance in network applications, the DS28E04-100 uses a new 1-Wire front end, which makes it less sensitive to noise and also reduces the magnitude of noise injected by the slave device itself.

The 1-Wire front end of the DS28E04-100 differs from traditional slave devices in four characteristics.

- 1) The falling edge of the presence pulse has a controlled slew rate. This provides a better match to the line impedance than a digitally switched transistor, converting the high-frequency ringing known from traditional devices into a smoother low-bandwidth transition. The slew-rate control is specified by the parameter  $t_{FPD}$ , which has different values for standard and Overdrive speed.
- 2) There is additional lowpass filtering in the circuit that detects the falling edge at the beginning of a time slot. This reduces the sensitivity to high-frequency noise. This additional filtering does not apply at Overdrive speed.
- 3) There is a hysteresis at the low-to-high switching threshold  $V_{TH}$ . If a negative glitch crosses  $V_{TH}$  but does not go below  $V_{TH} - V_{HY}$ , it will not be recognized (Figure 17, Case A). The hysteresis is effective at any 1-Wire speed.
- 4) There is a time window specified by the rising edge hold-off time  $t_{REH}$  during which glitches are ignored, even if they extend below  $V_{TH} - V_{HY}$  threshold (Figure 17, Case B,  $t_{GL} < t_{REH}$ ). Deep voltage droops or glitches that appear late after crossing the  $V_{TH}$  threshold and extend beyond the  $t_{REH}$  window cannot be filtered out and are taken as the beginning of a new time slot (Figure 17, Case C,  $t_{GL} \geq t_{REH}$ ).

Only devices that have the parameters  $t_{FPD}$ ,  $V_{HY}$ , and  $t_{REH}$  specified in their electrical characteristics use the improved 1-Wire front end.

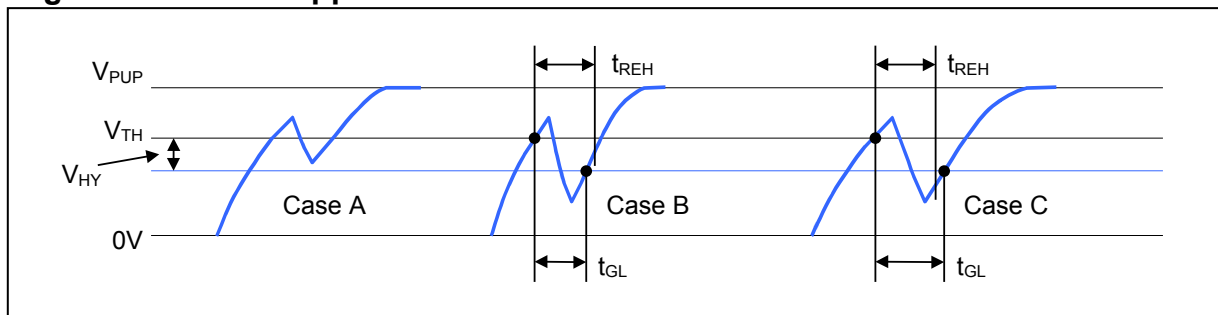
**Figure 17. Noise Suppression Scheme**

## CRC GENERATION

With the DS28E04-100 there are two different types of CRCs. One CRC is an 8-bit type and is stored in the most significant byte of the 64-bit ROM. The bus master can compute a CRC value from the first 56 bits of the ROM and, if none of the address inputs is connected to GND, compare it to the value stored within the DS28E04-100 to determine whether the ROM data has been received error-free. If any of the address pins are connected to GND, the bus master can calculate the CRC based on an all 1s external address field to determine whether the non-external address ROM data has been received error-free. The equivalent polynomial function of this CRC is  $X^8 + X^5 + X^4 + 1$ . This 8-bit CRC is received in the true (noninverted) form. It is computed at the factory and hardcoded into the ROM.

The other CRC is a 16-bit type, generated according to the standardized CRC16-polynomial function  $x^{16} + x^{15} + x^2 + 1$ . This CRC is used for fast verification of a data transfer when writing to or reading from the scratchpad or when reading from the PIOs. In contrast to the 8-bit CRC, the 16-bit CRC is always communicated in the inverted form. A CRC generator inside the DS28E04-100 chip (Figure 18) calculates a new 16-bit CRC, as shown in the command flow chart (Figure 9). The bus master compares the CRC value read from the device to the one it calculates from the data, and decides whether to continue with an operation or to reread the portion of the data with the CRC error.

With the Write Scratchpad command, the CRC is generated by first clearing the CRC generator and then shifting in the command code, the target addresses TA1 and TA2, and all the data bytes as they were sent by the bus master. The DS28E04-100 transmits this CRC only if E4:E0 = 11111b, i.e., the end of the scratchpad is hit.

With the Read Scratchpad command, the CRC is generated by first clearing the CRC generator and then shifting in the Command code, the target addresses TA1 and TA2, the E/S byte, and the scratchpad data as they were sent by the DS28E04-100. The DS28E04-100 transmits this CRC only if the reading continues through the end of the data written in the previous write scratchpad sequence. Example: if one writes a single byte to the scratchpad and then reads the scratchpad, one will receive a CRC of the command, TA1, TA2, and the data byte.

With the initial pass through the PIO Access Read command flow, the CRC is generated by first clearing the CRC generator and then shifting in the command code followed by 32 bytes of PIO pin data. Subsequent passes through the command flow generate a 16-bit CRC that is the result of clearing the CRC generator and then shifting in 32 bytes read from the PIO pins. For more information on generating CRC values, refer to *Application Note 27*.

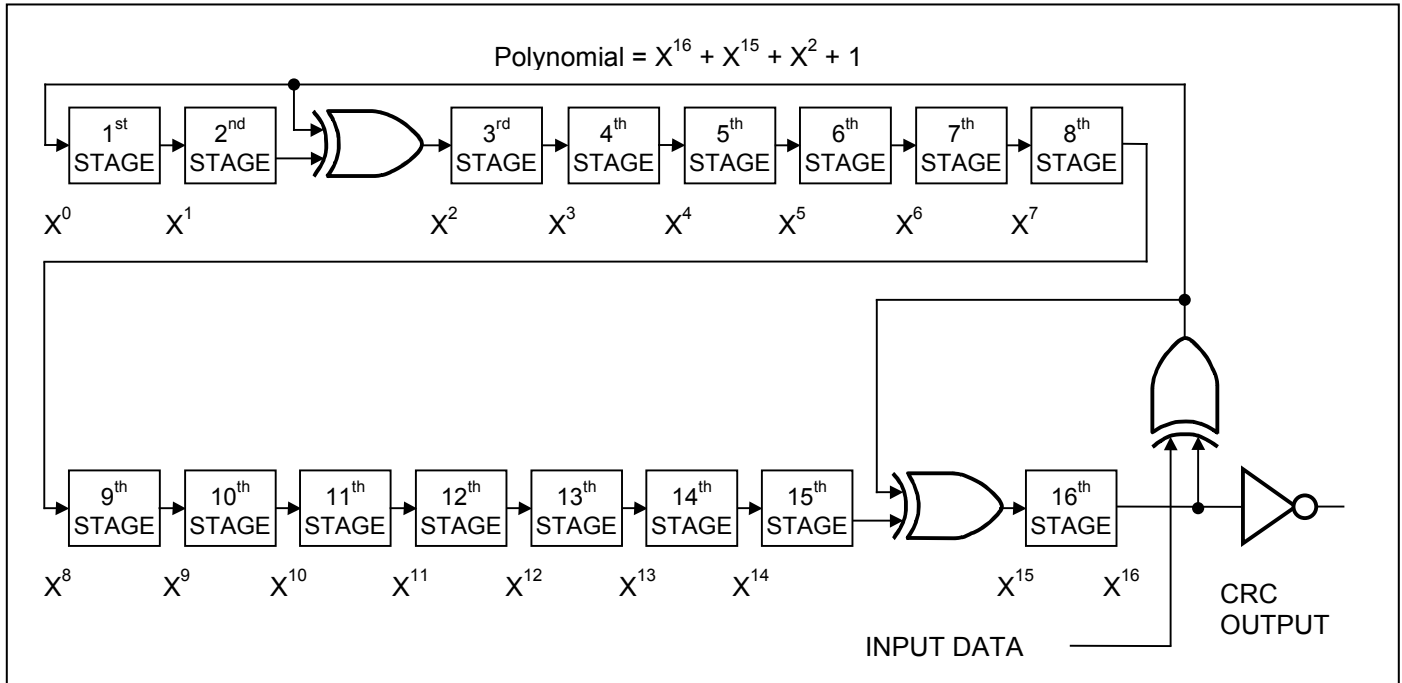
**Figure 18. CRC-16 Hardware Description and Polynomial****COMMAND-SPECIFIC 1-Wire COMMUNICATION PROTOCOL—LEGEND**

SYMBOL	DESCRIPTION
RST	1-Wire Reset Pulse generated by master.
PD	1-Wire Presence Pulse generated by slave.
Select	Command and data to satisfy the ROM function protocol.
WS	Command "Write Scratchpad".
RS	Command "Read Scratchpad".
CPS	Command "Copy Scratchpad".
RM	Command "Read Memory".
WREG	Command "Write Register".
PIOR	Command "PIO Access Read".
PIOW	Command "PIO Access Write".
PIOP	Command "PIO Access Pulse".
RAL	Command "Reset Activity Latches".
TA	Target address TA1, TA2.
TA-E/S	Target address TA1, TA2 with E/S byte.
<32 – T4:T0 bytes>	Transfer of as many bytes as needed to reach the end of the scratchpad for a given target address.
<data to EOM>	Transfer of as many data bytes as are needed to reach the end of the memory.
<register data>	Data for registers at addresses 223h to 225h, 1 to 3 bytes, depending on start address.
CRC16\	Transfer of an inverted CRC16.
FF loop	Indefinite loop where the master reads FF bytes.
AA loop	Indefinite loop where the master reads AA bytes.
Programming	Data transfer to EEPROM; no activity on the 1-Wire bus permitted during this time.

**COMMAND-SPECIFIC 1-Wire COMMUNICATION PROTOCOL—COLOR CODES**

Master to slave	Slave to master	Programming
-----------------	-----------------	-------------

**WRITE SCRATCHPAD (CANNOT FAIL)**

RST	PD	Select	WS	TA	<32 – T4:T0 bytes>	CRC16\	FF loop
-----	----	--------	----	----	--------------------	--------	---------

**READ SCRATCHPAD (CANNOT FAIL)**

RST	PD	Select	RS	TA-E/S	<E4:E0 - T4:T0 + 1 bytes>	CRC16\	FF loop
-----	----	--------	----	--------	---------------------------	--------	---------

**COPY SCRATCHPAD 1-Wire POWERED (SUCCESS)**

RST	PD	Select	CPS	TA-E/S	wait $t_{\text{PROGMAX}}$	AA loop
-----	----	--------	-----	--------	---------------------------	---------

**COPY SCRATCHPAD (INVALID ADDRESS OR PF = 1 OR COPY PROTECTED)**

RST	PD	Select	CPS	TA-E/S	FF loop
-----	----	--------	-----	--------	---------

**READ MEMORY (SUCCESS)**

RST	PD	Select	RM	TA	<data to EOM>	FF loop
-----	----	--------	----	----	---------------	---------

**READ MEMORY (INVALID ADDRESS)**

RST	PD	Select	RM	TA	FF loop
-----	----	--------	----	----	---------

**WRITE REGISTER (SUCCESS)**

RST	PD	Select	WREG	TA	<register data>	FF loop
-----	----	--------	------	----	-----------------	---------

**WRITE REGISTER (INVALID ADDRESS)**

RST	PD	Select	WREG	TA	FF loop
-----	----	--------	------	----	---------

**PIO ACCESS READ (CANNOT FAIL)**

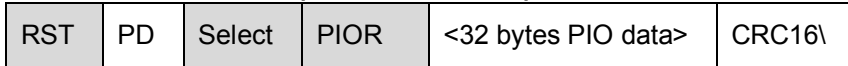

Loop until master sends Reset Pulse

**PIO ACCESS WRITE (SUCCESS)**

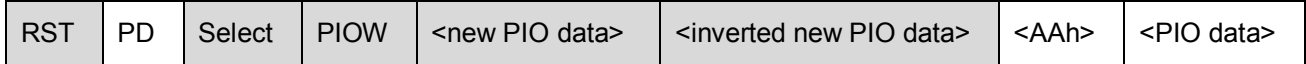

Loop until master sends Reset Pulse

**PIO ACCESS WRITE (INVALID DATA BYTE)**



**PIO ACCESS PULSE (SUCCESS)**

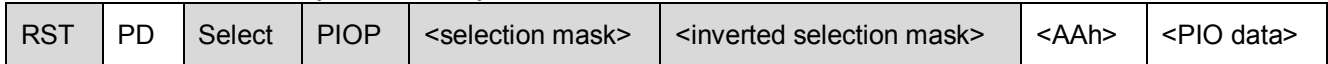

**PIO ACCESS PULSE (INVALID SELECTION MASK)**

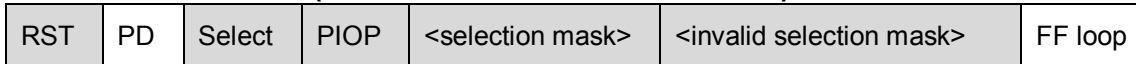

**RESET ACTIVITY LATCHES (CANNOT FAIL)**

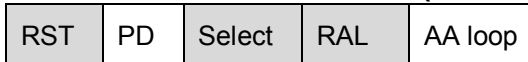

## MEMORY FUNCTION EXAMPLE

Write 5 bytes to memory page 1, starting at address 0021h. Read the entire memory and the PIO-related registers. With only a single DS28E04-100 connected to the bus master, the communication looks like this:

MASTER MODE	DATA (LSB FIRST)	COMMENTS
TX	(Reset)	Reset pulse
RX	(Presence)	Presence pulse
TX	CCh	Issue "Skip ROM" command
TX	0Fh	Issue "Write Scratchpad" command
TX	21h	TA1, beginning offset = 21h
TX	00h	TA2, address = 0021h
TX	<5 data bytes>	Write 5 bytes of data to scratchpad
TX	(Reset)	Reset pulse
RX	(Presence)	Presence pulse
TX	CCh	Issue "Skip ROM" command
TX	AAh	Issue "Read Scratchpad" command
RX	21h	Read TA1, beginning offset = 21h
RX	00h	Read TA2, address = 0021h
RX	05h	Read E/S, ending offset = 00101b, AA, PF = 0
RX	<5 data bytes>	Read scratchpad data and verify
RX	<2 bytes CRC16\>	Read CRC to check for data integrity
TX	(Reset)	Reset pulse
RX	(Presence)	Presence pulse
TX	CCh	Issue "Skip ROM" command
TX	55h	Issue "Copy Scratchpad" command
TX	21h	TA1
TX	00h	TA2 (AUTHORIZATION CODE)
TX	05h	E/S
----	<1-Wire idle high>	Wait 10ms for the copy function to complete
RX	AAh	Read copy status, AAh = success
TX	(Reset)	Reset pulse
RX	(Presence)	Presence pulse
TX	CCh	Issue "Skip ROM" command
TX	F0h	Issue "Read Memory" command
TX	00h	TA1, beginning offset = 00h
TX	00h	TA2, address = 0000h
RX	<550 data bytes>	Read the entire memory
TX	(Reset)	Reset pulse
RX	(Presence)	Presence pulse

## PIO ACCESS READ EXAMPLE

Read the state of the PIOs 32 times.

With only a single DS28E04-100 connected to the bus master, the communication looks like this:

MASTER MODE	DATA (LSB FIRST)	COMMENTS
TX	(Reset)	Reset pulse
RX	(Presence)	Presence pulse
TX	CCh	Issue "Skip ROM" command
TX	F5h	Issue "PIO Access Read" command
RX	<32 data bytes>	Read 32 PIO samples
RX	<2 bytes CRC16\>	Read CRC to check for data integrity
TX	(Reset)	Reset pulse
RX	(Presence)	Presence pulse

The inverted CRC16 is transmitted after 32 bytes of PIO data.

## PIO ACCESS WRITE EXAMPLE

Set both PIOs to 0 and then to 1. Both PIOs are pulled high to  $V_{CC}$  or  $V_{PUP}$  by a resistor.

With only a single DS28E04-100 connected to the bus master, the communication looks like this:

MASTER MODE	DATA (LSB FIRST)	COMMENTS
TX	(Reset)	Reset pulse
RX	(Presence)	Presence pulse
TX	CCh	Issue "Skip ROM" command
TX	5Ah	Issue "PIO Access Write" command
TX	FCh	Write new PIO output state
TX	03h	Write inverted new PIO output state
RX	AAh	Read confirmation byte
RX	FCh	Read new PIO pin status
TX	FFh	Write new PIO output state
TX	00h	Write inverted new PIO output state
RX	AAh	Read confirmation byte
RX	FFh	Read new PIO pin status
TX	(Reset)	Reset pulse
RX	(Presence)	Presence pulse

## PIO ACCESS PULSE EXAMPLE

Generate a pulse on PIO1. Both PIOs are pulled high to  $V_{CC}$  by a resistor. POL = 1.  $V_{CC}$  power is present. With only a single DS28E04-100 connected to the bus master, the communication looks like this:

MASTER MODE	DATA (LSB FIRST)	COMMENTS
TX	(Reset)	Reset pulse
RX	(Presence)	Presence pulse
TX	CCh	Issue "Skip ROM" command
TX	A5h	Issue "PIO Access Pulse" command
TX	FEh	Write PIO selection mask
TX	01h	Write inverted PIO selection mask
RX	AAh	Read confirmation byte
RX	1111110Xb	Read PIO pin status <sup>1)</sup>
TX	(Reset)	Reset pulse
RX	(Presence)	Presence pulse

<sup>1)</sup> The "X" indicates the state of PIO0, which is not defined in this example.

## PACKAGE INFORMATION

For the latest package outline information and land patterns (footprints), go to [www.maxim-ic.com/packages](http://www.maxim-ic.com/packages). Note that a "+", "#", or "-" in the package code indicates RoHS status only. Package drawings may show a different suffix character, but the drawing pertains to the package regardless of RoHS status.



PACKAGE TYPE	PACKAGE CODE	OUTLINE NO.	LAND PATTERN NO.
16 SO	S16+1	<a href="#">21-0041</a>	<a href="#">90-0097</a>

**REVISION HISTORY**

<b>REVISION DATE</b>	<b>DESCRIPTION</b>	<b>PAGES CHANGED</b>
102704	Initial release	—
12/11	Changed the <i>Ordering Information</i> for lead(Pb)-free product; updated the lead temperature and soldering temperature; extended the storage temperature range.	1, 2
	In the <i>Electrical Characteristics</i> table applied Note 19 to the $t_{W0L}$ specification, deleted $\epsilon$ from the $t_{W1L}$ specification, increased the data retention time, added more details to notes 10, 19 and 20, and added notes 23, 24.	3, 4
	Added <i>Package Information</i> section and <i>Revision History</i> .	36, 37

## Looking for pricing, stock, or lifecycle information?

Click below to explore more details on WIN SOURCE:

-  [View DS28E04S-100+T on WIN SOURCE](#)
-  [Maxim Integrated Information](#)

## Optimize Your Supply Chain with WIN SOURCE Solutions

-  Global Sourcing Solution
-  Obsolete Management
-  Cost Control Management
-  Shortage Management
-  Alternative Solution
-  Excess Inventory Management