

General Description

The AOZ8S301UD4-03 is a transient voltage suppressor array designed to protect high speed data lines such as HDMI 1.4/2.0, USB 3.0/3.1, LVDS, and V-by-one from damaging ESD events.

This device incorporates a numbers of surge rated, low capacitance steering diodes and a TVS in a single package. During transient conditions, the steering diodes direct the transient to either the positive side of the power supply line or to ground.

The AOZ8S301UD4-03 provides a typical line-to-line capacitance of 0.15 pF and low insertion loss providing greater signal integrity making it ideally suited for HDMI 1.4/2.0 or USB 3.0/3.1 applications, such as Digital TVs, DVD players, computing, set-top boxes and MDDI applications in mobile computing devices.

The AOZ8S301UD4-03 comes in a RoHS compliant and Halogen Free 2.5 mm x 1.0 mm x 0.55 mm DFN-10 package and is rated for -40°C to +125°C junction temperature range.

Features

- IEC 61000-4-2 (ESD):
 - Air discharge: ±15 kV
 - Contact discharge: ±15 kV
- IEC 61000-4-5 (Lightning, 8/20 μs) 5 A
- Human Body Model (HBM) ±8 kV
- Protects four I/O lines
- Low capacitance between I/O to GND: 0.28 pF
- Low clamping voltage
- Low operating voltage: 3.3 V

Applications

- HDMI 1.4/2.0, USB 3.0/3.1, Thunderbolt, V-by-One
- Monitors and flat panel displays
- Set-top box
- Video graphics cards
- Notebook computers



Typical Applications

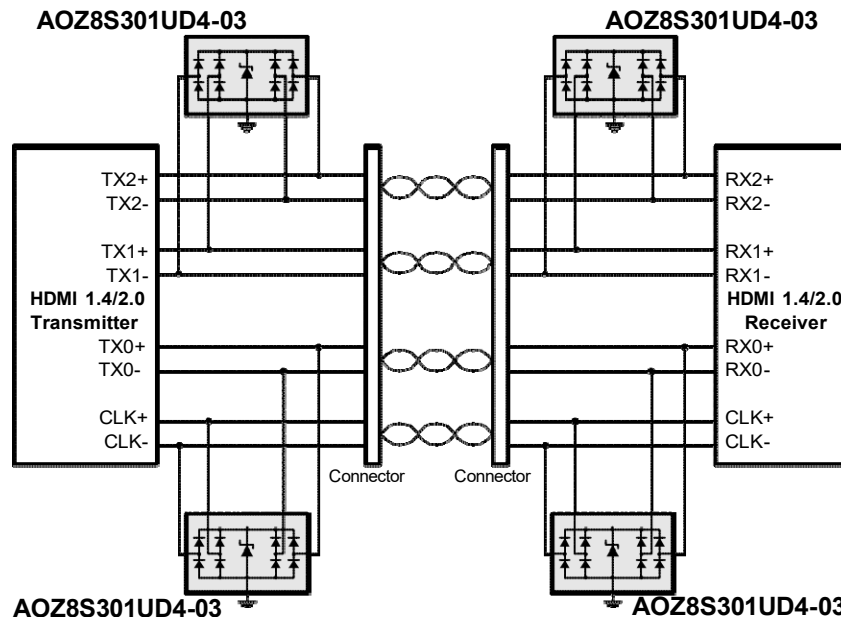

Ordering Information

Part Number	Ambient Temperature Range	Package	Environmental
AOZ8S301UD4-03	-40°C to +125°C	2.5 mm x 1.0 mm DFN-10	Green Product



AOS Green Products use reduced levels of Halogens, and are also RoHS compliant.

Pin Configuration

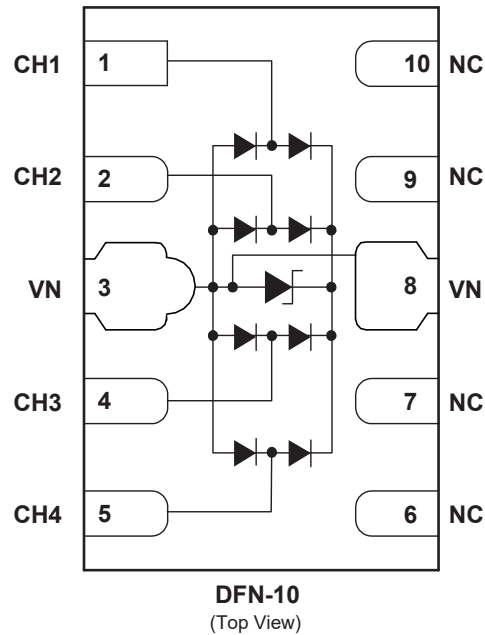

Absolute Maximum Ratings

Exceeding the Absolute Maximum ratings may damage the device.

Parameter	Rating
Storage Temperature (T_S)	-65 °C to +150 °C
ESD Rating per IEC 61000-4-2, contact ⁽¹⁾	±15 kV
ESD Rating per IEC 61000-4-2, air ⁽¹⁾	±15 kV
ESD Rating per Human Body Model ⁽²⁾	±8 kV

Notes:

- IEC 61000-4-2 discharge with $C_{Discharge} = 150\text{pF}$, $R_{Discharge} = 330\ \Omega$.
- Human Body Discharge per MIL-STD-883, Method 3015 $C_{Discharge} = 100\ \text{pF}$, $R_{Discharge} = 1.5\ \text{k}\Omega$.

Maximum Operating Ratings

Parameter	Rating
Junction Temperature (T_J)	-40 °C to +125 °C

Electrical Characteristics

$T_A = 25^\circ\text{C}$ unless otherwise specified. Any I/O Pin-to-Ground.

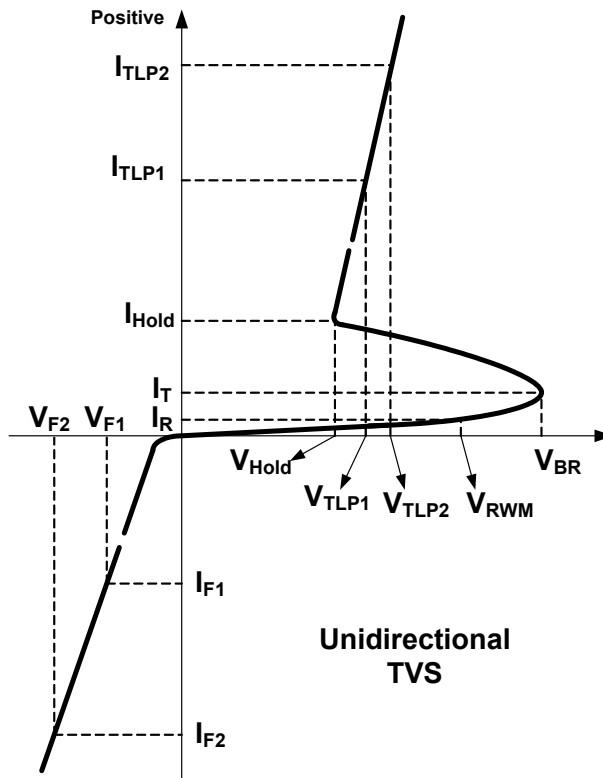

Symbol	Parameter	Conditions	Min.	Typ.	Max	Units
V_{RWM}	Reverse Working Voltage				3.3	V
V_{BR}	Reverse Breakdown Voltage	$I_T = 100 \mu\text{A}$	5			V
I_R	Reverse Leakage Current	Max. V_{RWM}		1	50	nA
V_{CL}	Clamping Voltage ⁽³⁾⁽⁴⁾ (100 ns Transmission Line Pulse, I/O Pin to GND)	$I_{TLP} = 1 \text{ A}$ $I_{TLP} = -1 \text{ A}$		1.3 -1.3	2 -2	V V
		$I_{TLP} = 16 \text{ A}$ $I_{TLP} = -16 \text{ A}$		5.5 -5	7 -6	V V
R_{DNY}	Dynamic Resistance ⁽³⁾	$I_{TLP} = 8 \text{ A to } 16 \text{ A}$		0.3		Ω
C_J	Junction Capacitance	$V_{PIN\ 3,8} = 0 \text{ V}, V_{I/O} = 1.65 \text{ V}, f = 1 \text{ MHz}$		0.28	0.34	pF
		$V_{PIN\ 3,8} = 0 \text{ V}, V_{I/O} = 1.65 \text{ V}, f = 1 \text{ MHz},$ I/O Pin-to-I/O Pin		0.15		pF

Notes:

- These specifications are guaranteed by design and characterization.
- Measurements performed using a 100ns Transmission Line Pulse (TLP) system.

Typical Characteristics

Typical Variations of C_J vs. Input Voltage

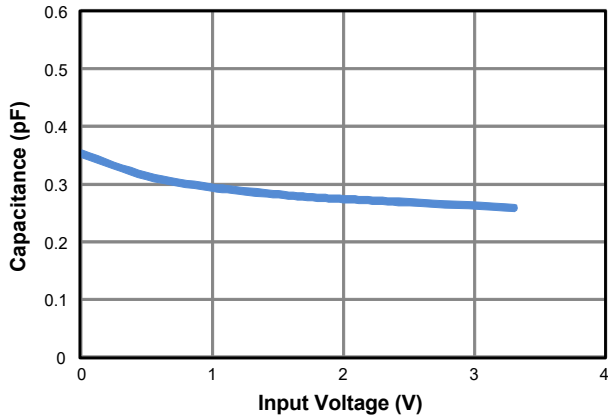

IEC61000-4-5 Surge 8/20 μ s

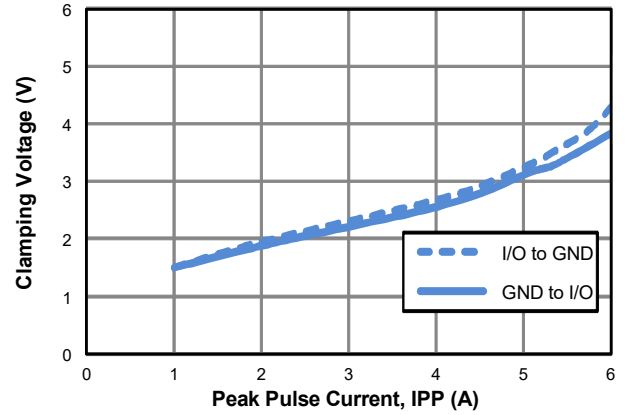

Positive Transmission Line Pulse
($T_P=100\text{ns}$, $T_R=0.2\text{ns}$)

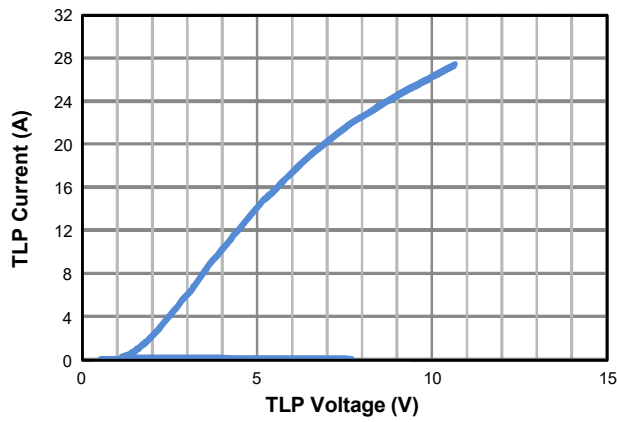

Negative Transmission Line Pulse
($T_P=100\text{ns}$, $T_R=0.2\text{ns}$)

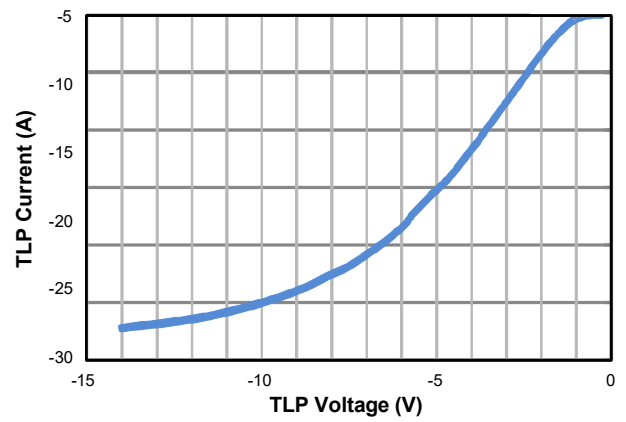

High Speed PCB Layout Guidelines

Printed circuit board layout is the key to achieving the highest level of surge immunity on power and data lines. The location of the protection devices on the PCB is the simplest and most important design rule to follow. The AOZ8S301UD4-03 devices should be located as close as possible to the noise source. The AOZ8S301UD4-03 device should be placed on all data and power lines that enter or exit the PCB at the I/O connector. In most systems, surge pulses occur on data and power lines that enter the PCB through the I/O connector. Placing the AOZ8S301UD4-03 devices as close as possible to the noise source ensures that a surge voltage will be clamped before the pulse can be coupled into adjacent PCB traces.

In addition, the PCB should use the shortest possible traces. A short trace length equates to low impedance, which ensures that the surge energy will be dissipated by the AOZ8S301UD4-03 device. Long signal traces will act as antennas to receive energy from fields that are produced by the ESD pulse. By keeping line lengths as short as possible, the efficiency of the line to act as an antenna for ESD related fields is reduced. Minimize interconnecting line lengths by placing devices with the most interconnect as close together as possible. The protection circuits should shunt the surge voltage to either the reference or chassis ground. Shunting the surge voltage directly to the IC's signal ground can cause ground bounce. The clamping performance of TVS

diodes on a single ground PCB can be improved by minimizing the impedance with relatively short and wide ground traces. The PCB layout and IC package parasitic inductances can cause significant overshoot to the TVS's clamping voltage. The inductance of the PCB can be reduced by using short trace lengths and multiple layers with separate ground and power planes. One effective method to minimize loop problems is to incorporate a ground plane in the PCB design.

The AOZ8S301UD4-03 ultra-low capacitance TVS is designed to protect four high speed data transmission lines from transient over-voltages by clamping them to a fixed reference. The low inductance and construction minimizes voltage overshoot during high current surges. When the voltage on the protected line exceeds the reference voltage the internal steering diodes are forward biased, conducting the transient current away from the sensitive circuitry. The AOZ8S301UD4-03 is designed for ease of PCB layout by allowing the traces to run underneath the device. The pinout of the AOZ8S301UD4-03 is designed to simply drop onto the IO lines of a High Definition Multimedia Interface (HDMI 1.4/2.0) or USB 3.0/3.1 design without having to divert the signal lines that may add more parasitic inductance. Pins 1, 2, 4 and 5 are connected to the internal TVS devices and pins 6, 7, 9 and 10 are no connects. The no connects was done so the package can be securely soldered onto the PCB surface.

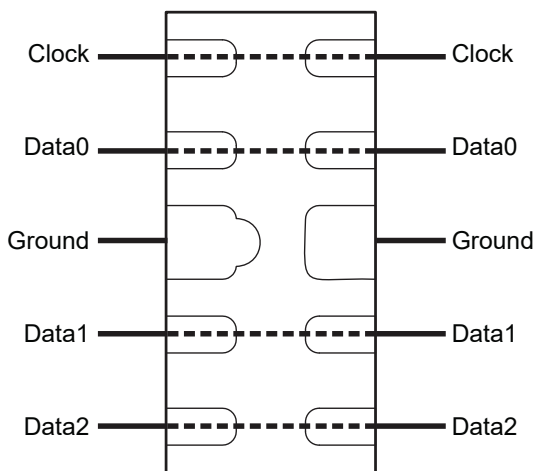

Figure 3. Flow Through Layout for HDMI 1.4/2.0

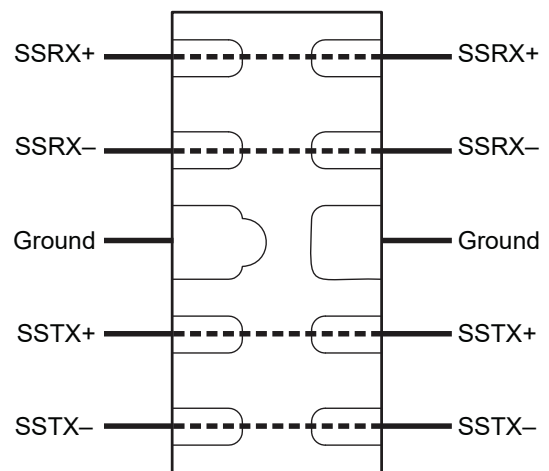
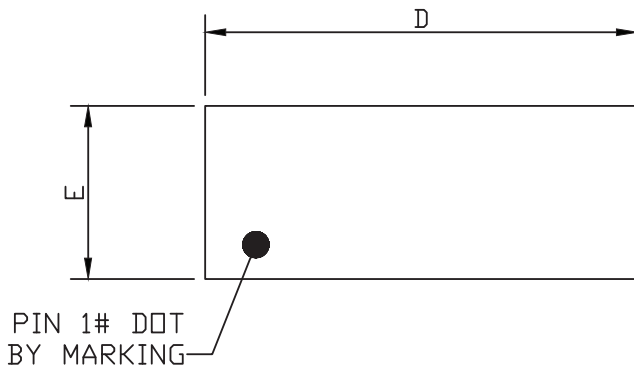
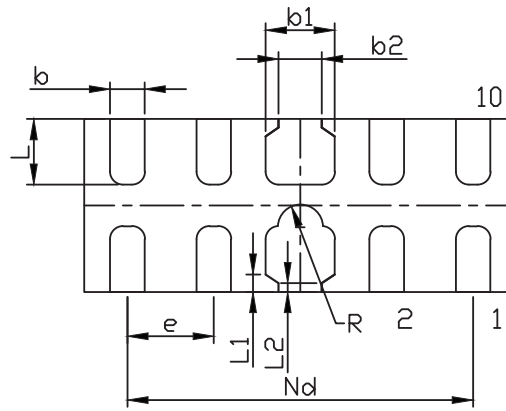

Figure 4. Flow Through Layout for USB 3.0/3.1

Package Dimensions, DFN 2.5 x 1.0A, 10L EPS_S



TOP VIEW



BOTTOM VIEW

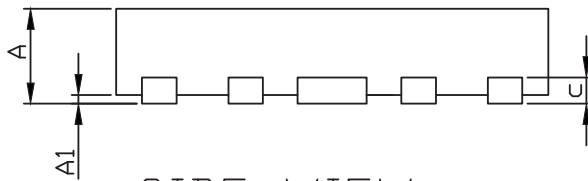

SIDE VIEW

RECOMMENDED LAND PATTERN

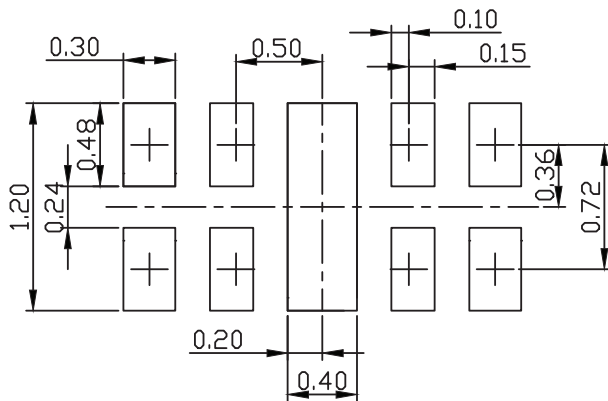

UNIT: mm

SYMBOLS	DIMENSIONS IN MILLIMETERS			DIMENSIONS IN INCHES		
	MIN	NOM	MAX	MIN	NOM	MAX
A	0.45	0.50	0.55	0.0177	0.0197	0.0217
A1	---	0.02	0.05	---	0.0007	0.0019
b	0.15	0.20	0.25	0.0059	0.0078	0.0098
b1	0.35	0.40	0.45	0.0137	0.0157	0.0177
b2	0.20	0.25	0.30	0.0078	0.0098	0.0118
c	0.10	0.15	0.20	0.0039	0.0059	0.0078
D	2.45	2.50	2.55	0.0964	0.0984	0.1003
e	0.50 BSC			0.0196 BSC		
Nd	2.00 BSC			0.0787 BSC		
E	0.95	1.00	1.05	0.0374	0.0393	0.0413
L	0.33	0.38	0.43	0.0129	0.0150	0.0169
L1	0.075 Ref.			0.0030 Ref.		
L2	0.050 Ref.			0.0020 Ref.		
R	0.08	0.13	0.18	0.0031	0.0051	0.0071

NOTE

1. CONTROLLING DIMENSION IS MILLIMETER.
CONVERTED INCH DIMENSIONS ARE NOT NECESSARILY EXACT.

Tape and Reel Dimensions, DFN 2.5 x 1.0A, 10L

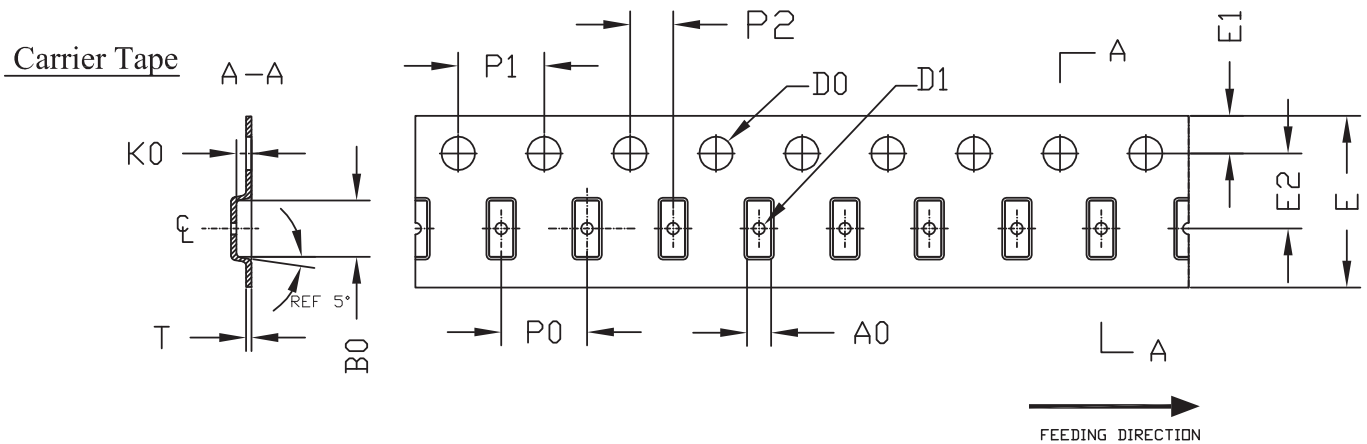

UNIT: MM

PACKAGE	A0	B0	K0	D0	D1	E	E1	E2	P0	P1	P2	T
DFN 2.5X1.0	1.12 ±0.05	2.62 ±0.05	0.70 ±0.05	∅1.55 ±0.05	∅0.55 ±0.05	8.00 +0.3 -0.1	1.75 ±0.1	3.50 ±0.05	4.00 ±0.1	4.0 ±0.10	2.0 ±0.05	0.25 ±0.05

REEL

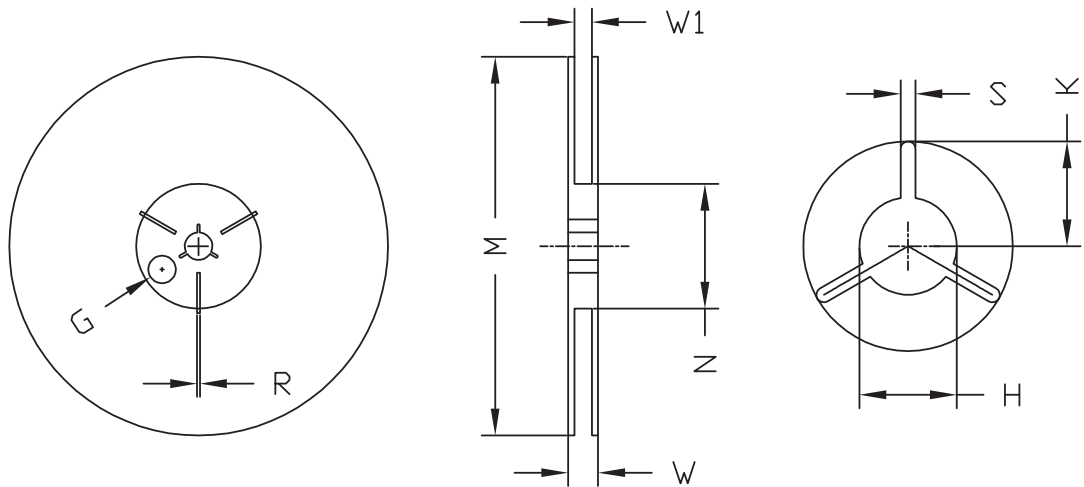

UNIT: MM

TAPE SIZE	REEL SIZE	M	N	W	W1	H	S	K	G	R
8	∅178	∅178.0 ±1.0	∅60.0 ±1.0	11.80 ±0.5	9.0 ±0.5	∅13.0 +0.5 -0.2	2.40 ±0.10	10.25 ±0.2	∅9.8	---

TAPE

Leader / Trailer
& Orientation

Unit Per Reel:
3000pcs

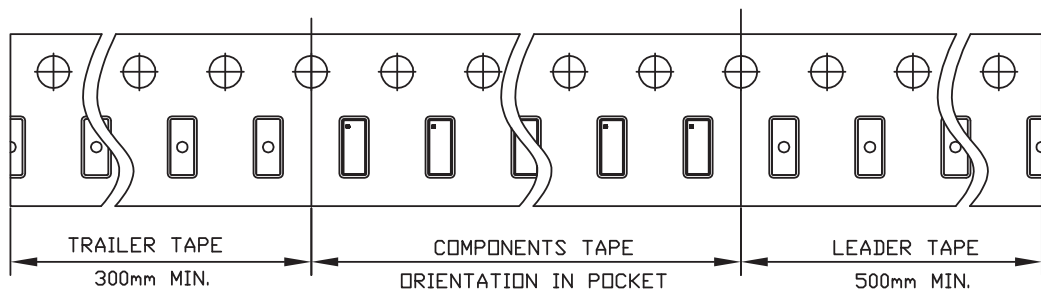

Part Marking

AOZ8S301UD4-03
(DFN 2.5 x 1.0, 10L)

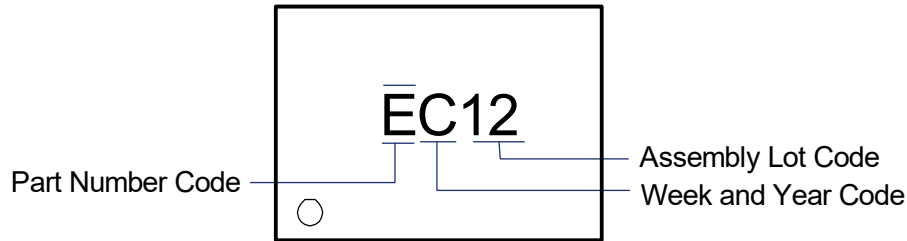

LEGAL DISCLAIMER

Applications or uses as critical components in life support devices or systems are not authorized. AOS does not assume any liability arising out of such applications or uses of its products. AOS reserves the right to make changes to product specifications without notice. It is the responsibility of the customer to evaluate suitability of the product for their intended application. Customer shall comply with applicable legal requirements, including all applicable export control rules, regulations and limitations.

AOS' products are provided subject to AOS' terms and conditions of sale which are set forth at:
http://www.aosmd.com/terms_and_conditions_of_sale

LIFE SUPPORT POLICY

ALPHA AND OMEGA SEMICONDUCTOR PRODUCTS ARE NOT AUTHORIZED FOR USE AS CRITICAL COMPONENTS IN LIFE SUPPORT DEVICES OR SYSTEMS.

As used herein:

- | | |
|---|---|
| <p>1. Life support devices or systems are devices or systems which, (a) are intended for surgical implant into the body or (b) support or sustain life, and (c) whose failure to perform when properly used in accordance with instructions for use provided in the labeling, can be reasonably expected to result in a significant injury of the user.</p> | <p>2. A critical component in any component of a life support, device, or system whose failure to perform can be reasonably expected to cause the failure of the life support device or system, or to affect its safety or effectiveness.</p> |
|---|---|

Looking for pricing, stock, or lifecycle information?

Click below to explore more details on WIN SOURCE:

- ⊖ [View AOZ8S301UD4-03 on WIN SOURCE](#)
- ⊖ [Alpha & Omega Semiconductor Inc. Information](#)

Optimize Your Supply Chain with WIN SOURCE Solutions

- ✓ Global Sourcing Solution
- ✓ Obsolete Management
- ✓ Cost Control Management
- ✓ Shortage Management
- ✓ Alternative Solution
- ✓ Excess Inventory Management