



**THE DATASHEET OF
9FG1201HGLFT**



Frequency Gearing Clock for CPU, PCIe Gen1, Gen2, & FBD

ICS9FG1201H

Description

The ICS9FG1201H follows the Intel DB1200G Rev 1.0 Differential Buffer Specification. This buffer provides 12 output clocks for CPU Host Bus, PCI-Express, or Fully Buffered DIMM applications. The outputs are configured with two groups. Both groups (DIF 9:0) and (DIF 11:10) can be equal to or have a gear ratio to the input clock. A differential CPU clock from a CK410B or CK410B+ main clock generator, such as the ICS932S421, drives the ICS9FG1201. The ICS9FG1201H can provide outputs up to 400MHz

Features/Benefits

- Drives 2 channels of 4 FBDIMMs (total of 8 FBDIMMs)
- Power up default is all outputs in 1:1 mode
- DIF_(9:0) can be “gear-shifted” from the input CPU Host Clock
- DIF_(11:10) can be “gear-shifted” from the input CPU Host Clock
- Spread spectrum compatible
- Supports output clock frequencies up to 400 MHz
- 8 Selectable SMBus addresses
- SMBus address determines PLL or Bypass mode

Key Specifications

- DIF output cycle-to-cycle jitter < 50ps
- DIF output-to-output skew < 50ps within a group
- DIF output-to-output skew < 100ps across all outputs
- 56-pin SSOP/TSSOP package
- RoHS compliant packaging

Functional Block Diagram

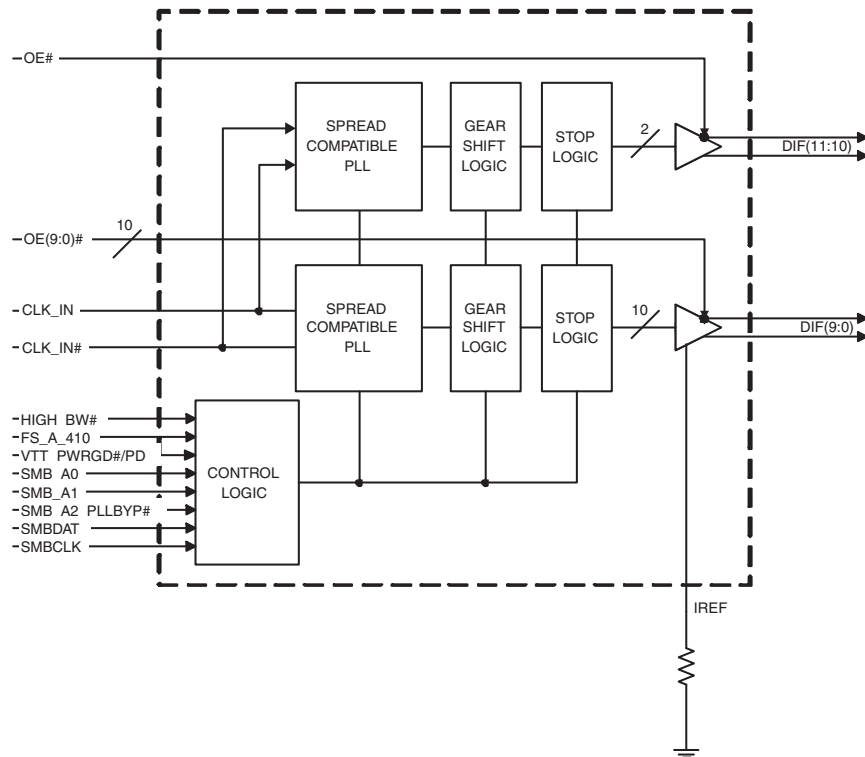

Pin Configuration

HIGH_BW#	1	56	VDDA
CLK_IN	2	55	GNDA
CLK_IN#	3	54	IREF
SMB_A0	4	53	OE10_11#
OE0#	5	52	DIF_11
DIF_0	6	51	DIF_11#
DIF_0#	7	50	VDD
OE1#	8	49	GND
DIF_1	9	48	DIF_10
DIF_1#	10	47	DIF_10#
VDD	11	46	FS_A_410
GND	12	45	VTT_PWRGD#/PD
DIF_2	13	44	OE9#
DIF_2#	14	43	DIF_9
OE2#	15	42	DIF_9#
DIF_3	16	41	OE8#
DIF_3#	17	40	DIF_8
OE3#	18	39	DIF_8#
DIF_4	19	38	VDD
DIF_4#	20	37	GND
OE4#	21	36	DIF_7
VDD	22	35	DIF_7#
GND	23	34	OE7#
DIF_5	24	33	DIF_6
DIF_5#	25	32	DIF_6#
OE5#	26	31	OE6#
SMB_A1	27	30	SMB_A2_PLLBYP#
SMBDAT	28	29	SMBCLK

ICS9FG1201H

56-pin SSOP & TSSOP

Functionality Table

FS_A_410 ¹	CLK_IN (CPU FSB) MHz	DIF_(9:0) Output MHz	DIF_(11:10) Output MHz
1	100.00	100.00	100.00
1	133.33	133.33	133.33
1	166.66	166.66	166.66
1	RESERVED		
0	200.00	200.00	200.00
0	266.66	266.66	266.66
0	333.33	333.33	333.33
0	400.00	400.00	400.00

1. FS_A_410 is a low-threshold input. Please see the V_{IL_FS} and V_{IH_FS} specifications in the Input/Supply/Common Output Parameters Table for correct values.

Power Groups

Pin Number		Description
VDD	GND	
56	55	Main PLL, Analog
11,22,38,50	12,23,37,49	DIF clocks

Pin Description

Pin #	Pin Name	Type	Pin Description
1	HIGH_BW#	IN	3.3V input for selecting PLL Band Width 0 = High, 1 = Low
2	CLK_IN	IN	Input for reference clock.
3	CLK_IN#	IN	"Complementary" reference clock input.
4	SMB_A0	IN	SMBus address bit 0 (LSB)
5	OE0#	IN	Active low input for enabling DIF pair 0. 1 = tri-state outputs, 0 = enable outputs
6	DIF_0	OUT	0.7V differential true clock output
7	DIF_0#	OUT	0.7V differential complement clock output
8	OE1#	IN	Active low input for enabling DIF pair 1. 1 = tri-state outputs, 0 = enable outputs
9	DIF_1	OUT	0.7V differential true clock output
10	DIF_1#	OUT	0.7V differential complement clock output
11	VDD	PWR	Power supply, nominal 3.3V
12	GND	PWR	Ground pin.
13	DIF_2	OUT	0.7V differential true clock output
14	DIF_2#	OUT	0.7V differential complement clock output
15	OE2#	IN	Active low input for enabling DIF pair 2. 1 = tri-state outputs, 0 = enable outputs
16	DIF_3	OUT	0.7V differential true clock output
17	DIF_3#	OUT	0.7V differential complement clock output
18	OE3#	IN	Active low input for enabling DIF pair 3. 1 = tri-state outputs, 0 = enable outputs
19	DIF_4	OUT	0.7V differential true clock output
20	DIF_4#	OUT	0.7V differential complement clock output
21	OE4#	IN	Active low input for enabling DIF pair 4 1 = tri-state outputs, 0 = enable outputs
22	VDD	PWR	Power supply, nominal 3.3V
23	GND	PWR	Ground pin.
24	DIF_5	OUT	0.7V differential true clock output
25	DIF_5#	OUT	0.7V differential complement clock output
26	OE5#	IN	Active low input for enabling DIF pair 5. 1 = tri-state outputs, 0 = enable outputs
27	SMB_A1	IN	SMBus address bit 1
28	SMBDAT	I/O	Data pin of SMBUS circuitry, 5V tolerant

Pin Description (continued)

Pin #	Pin Name	Type	Pin Description
29	SMBCLK	IN	Clock pin of SMBUS circuitry, 5V tolerant
30	SMB_A2_PLLBYP#	IN	SMBus address bit 2. When Low, the part operates as a fanout buffer with the PLL bypassed. When High, the part operates as a zero-delay buffer (ZDB) with the PLL operating. 0 = fanout mode (PLL bypassed), 1 = ZDB mode (PLL used)
31	OE6#	IN	Active low input for enabling DIF pair 6. 1 = tri-state outputs, 0 = enable outputs
32	DIF_6#	OUT	0.7V differential complement clock output
33	DIF_6	OUT	0.7V differential true clock output
34	OE7#	IN	Active low input for enabling DIF pair 7. 1 = tri-state outputs, 0 = enable outputs
35	DIF_7#	OUT	0.7V differential complement clock output
36	DIF_7	OUT	0.7V differential true clock output
37	GND	PWR	Ground pin.
38	VDD	PWR	Power supply, nominal 3.3V
39	DIF_8#	OUT	0.7V differential complement clock output
40	DIF_8	OUT	0.7V differential true clock output
41	OE8#	IN	Active low input for enabling DIF pair 8. 1 = tri-state outputs, 0 = enable outputs
42	DIF_9#	OUT	0.7V differential complement clock output
43	DIF_9	OUT	0.7V differential true clock output
44	OE9#	IN	Active low input for enabling DIF pair 9. 1 = tri-state outputs, 0 = enable outputs
45	VTT_PWRGD#/PD	IN	Vtt_PwrGd# is an active low input used to determine when latched inputs are ready to be sampled. PD is an asynchronous active high input pin used to put the device into a low power state. The internal clocks, PLLs and the crystal oscillator are stopped.
46	FS_A_410	IN	3.3V tolerant low threshold input for CPU frequency selection. This pin requires CK410 FSA. Refer to input electrical characteristics for Vil_FS and Vih_FS threshold values.
47	DIF_10#	OUT	0.7V differential complement clock output
48	DIF_10	OUT	0.7V differential true clock output
49	GND	PWR	Ground pin.
50	VDD	PWR	Power supply, nominal 3.3V
51	DIF_11#	OUT	0.7V differential complement clock output
52	DIF_11	OUT	0.7V differential true clock output
53	OE10_11#	IN	Active low input for enabling output pairs 10 and 11. 1 = tri-state outputs, 0 = enable outputs
54	IREF	OUT	This pin establishes the reference current for the differential current-mode output pairs. This pin requires a fixed precision resistor tied to ground in order to establish the appropriate current. 475 ohms is the standard value.
55	GNDA	PWR	Ground pin for the PLL core.
56	VDDA	PWR	3.3V power for the PLL core.

ICS9FG1201 Programmable Gear Ratios

FS_A_410	SMBus Byte 0				Input (m)	Output (n)	Gear Ratio (n/m)	Input (CPU FSB) and Output Frequencies (MHz)				
	Bit 3	Bit 2	Bit 1	Bit 0				200.0	266.7	320.0	333.3	400.0
0	0	0	0	0	3	1	0.333	66.7	88.9	106.7	111.1	133.3
0	0	0	0	1	5	2	0.400	80.0	106.7	128.0	133.3	160.0
0	0	0	1	0	12	5	0.417	83.3	111.1	133.3	138.9	166.7
0	0	0	1	1	2	1	0.500	100.0	133.3	160.0	166.7	200.0
0	0	1	0	0	5	3	0.600	120.0	160.0	192.0	200.0	240.0
0	0	1	0	1	8	5	0.625	125.0	166.7	200.0	208.3	250.0
0	0	1	1	0	3	2	0.667	133.3	177.8	213.3	222.2	266.7
0	0	1	1	1	4	3	0.750	150.0	200.0	240.0	250.0	300.0
0	1	0	0	0	6	5	0.833	166.7	222.2	266.7	277.8	333.3
0	1	0	0	1	1	1	1.000	200.0	266.7	320.0	333.3	400.0
0	1	0	1	0	5	6	1.200	240.0	320.0	384.0	400.0	NA
0	1	0	1	1	4	5	1.250	250.0	333.3	400.0	NA	NA
0	1	1	0	0	3	4	1.333	266.7	355.6	NA	NA	NA
0	1	1	0	1	2	3	1.500	300.0	400.0	NA	NA	NA
0	1	1	1	0	3	5	1.667	333.3	NA	NA	NA	NA
0	1	1	1	1	1	2	2.000	400.0	NA	NA	NA	NA
								CLK IN (CPU FSB) Frequency (MHz)				
								100	133.33	160	166.67	
1	0	0	0	0	3	1	0.333					
1	0	0	0	1	5	2	0.400	NA	53.3	64.0	66.7	
1	0	0	1	0	12	5	0.417	NA	55.6	66.7	69.4	
1	0	0	1	1	2	1	0.500	50.0	66.7	80.0	83.3	
1	0	1	0	0	5	3	0.600	60.0	80.0	96.0	100.0	
1	0	1	0	1	8	5	0.625	62.5	83.3	100.0	104.2	
1	0	1	1	0	3	2	0.667	66.7	88.9	106.7	111.1	
1	0	1	1	1	5	4	0.800	80.0	106.7	128.0	133.3	
1	1	0	0	0	6	5	0.833	NA	111.1	133.3	138.9	
1	1	0	0	1	1	1	1.000	100.0	133.3	160.0	166.7	
1	1	0	1	0	5	6	1.200	120.0	160.0	192.0	200.0	
1	1	0	1	1	4	5	1.250	125.0	166.7	200.0	208.3	
1	1	1	0	0	3	4	1.333	133.3	177.8	213.3	222.2	
1	1	1	0	1	2	3	1.500	150.0	200.0			
1	1	1	1	0	3	5	1.667	166.7	222.2	266.7	277.8	
1	1	1	1	1	1	2	2.000	200.0	266.7	320.0	333.3	

Note: Lines in **BOLD** are Power-up defaults for FS_A_410 = 0 and 1 respectively.

Shaded areas are shown for reference only and are not necessarily valid operating points

ICS 9FG1201H 1:1 PLL Programming

Byte 8, bit 2 FSC	Byte 8, bit 1 FSB	Byte 8, bit 0 FS_A_410	CLK_IN (CPU FSB) MHz	1:1 DIF Outputs MHz	Notes
1	0	1	100.00	100.00	3
0	0	1	133.33	133.33	3
0	1	1	166.67	166.67	1
0	1	0	200.00	200.00	3
0	0	0	266.67	266.67	3
1	0	0	333.33	333.33	3
1	1	0	400.00	400.00	2
1	1	1	Reserved		

Notes:FS_A_410 = 1

1. Powerup Default for FS_A_410 = 1
2. Powerup Default for FS_A_410 = 0
3. Setting the exact FSB frequency after Power up is required for best phase noise performance.

**9FG1201/2 SMBus Address Mapping
 when using CK410B+ and DB400/800**

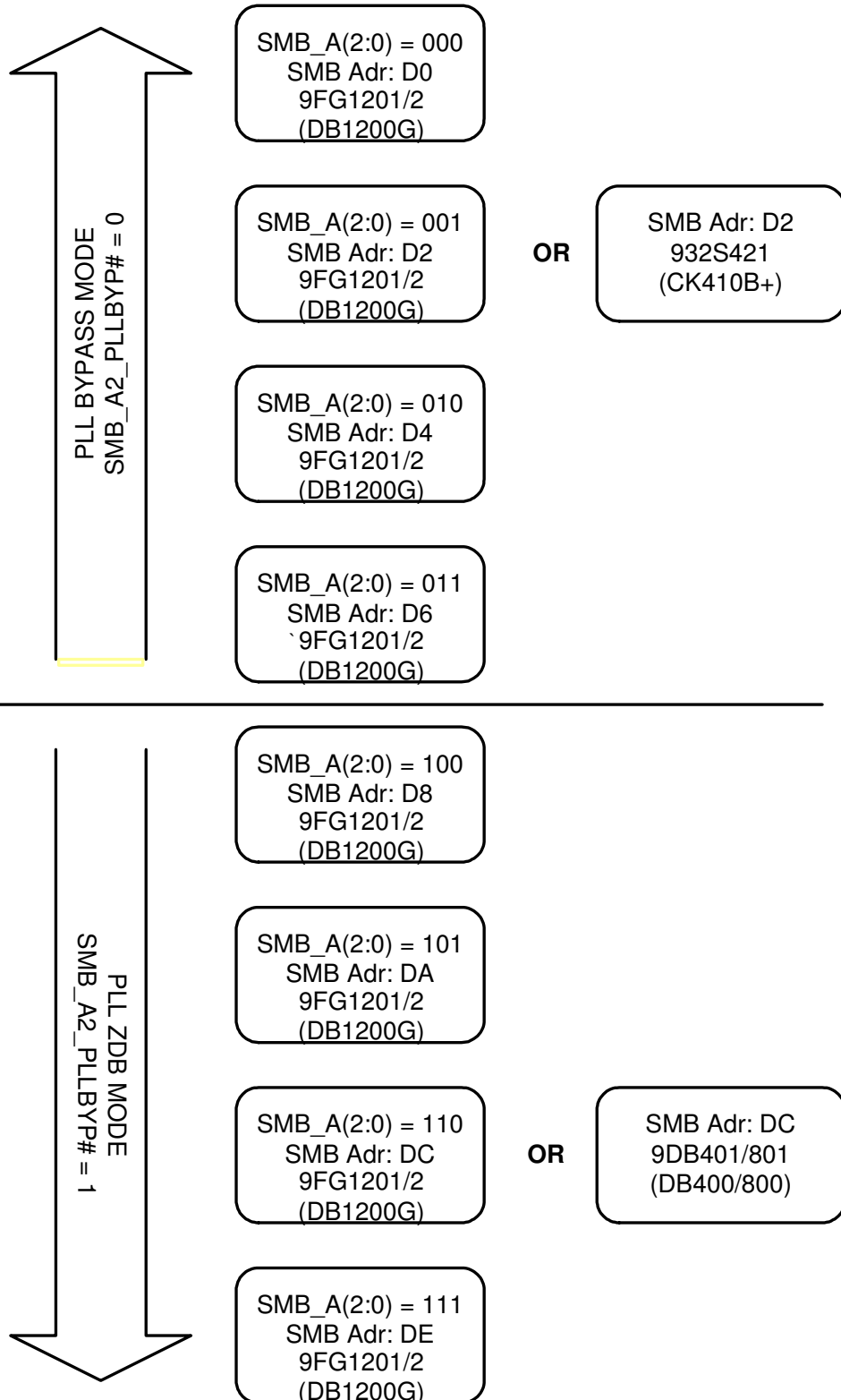

General SMBus serial interface information for the ICS9FG1201H

How to Write:

- Controller (host) sends a start bit.
- Controller (host) sends the write address $D0_{(h)}$
- ICS clock will **acknowledge**
- Controller (host) sends the beginning byte location = N
- ICS clock will **acknowledge**
- Controller (host) sends the data byte count = X
- ICS clock will **acknowledge**
- Controller (host) starts sending **Byte N through Byte N + X - 1**
- ICS clock will **acknowledge** each byte **one at a time**
- Controller (host) sends a Stop bit

How to Read:

- Controller (host) will send start bit.
- Controller (host) sends the write address $D0_{(h)}$
- ICS clock will **acknowledge**
- Controller (host) sends the beginning byte location = N
- ICS clock will **acknowledge**
- Controller (host) will send a separate start bit.
- Controller (host) sends the read address $D1_{(h)}$
- ICS clock will **acknowledge**
- ICS clock will send the data byte count = X
- ICS clock sends **Byte N + X - 1**
- ICS clock sends **Byte 0 through byte X (if $X_{(h)}$ was written to byte 8).**
- Controller (host) will need to acknowledge each byte
- Controller (host) will send a not acknowledge bit
- Controller (host) will send a stop bit

Index Block Write Operation		
Controller (Host)		ICS (Slave/Receiver)
T	starT bit	
Slave Address $D0_{(h)}$ *		
WR	WRite	
		ACK
Beginning Byte = N		
		ACK
Data Byte Count = X		
		ACK
Beginning Byte N	X Byte	
○		ACK
○		○
○		○
Byte N + X - 1		○
		ACK
P	stoP bit	

Index Block Read Operation		
Controller (Host)		ICS (Slave/Receiver)
T	starT bit	
Slave Address $D0_{(h)}$ *		
WR	WRite	
		ACK
Beginning Byte = N		
		ACK
RT	Repeat starT	
Slave Address $D1_{(h)}$ *		
RD	ReaD	
		ACK
		Data Byte Count = X
ACK		
ACK		Beginning Byte N
○		○
○		○
○		○
		Byte N + X - 1
N	Not acknowledge	
P	stoP bit	

* Note: See SMBus Address Mapping (page 7), for programming SMBus Read/Write Address

SMBusTable: Gear Ratio Select Register

Byte 0	Pin #	Name	Control Function	Type	0	1	PWD
Bit 7	DIF(9:0)	Group of 10 gear ratio enable		RW	Gear Ratio	1:1	1
Bit 6	DIF(11:10)	Group of 2 gear ratio enable		RW	Gear Ratio	1:1	1
Bit 5	-	Reserved		RW			1
Bit 4	-	Gear Ratio FS4 (FS A 410)		RW	See 9FG1201 Programmable Gear Ratios Table		Latch
Bit 3	-	Gear Ratio FS3		RW			1
Bit 2	-	Gear Ratio FS2		RW			0
Bit 1	-	Gear Ratio FS1		RW			1
Bit 0	-	Gear Ratio FS0		RW			1

SMBusTable: Output Control Register

Byte 1	Pin #	Name	Control Function	Type	0	1	PWD
Bit 7	35, 36	DIF_7	Output Control	RW	Hi-Z	Enable	1
Bit 6	32, 33	DIF_6	Output Control	RW	Hi-Z	Enable	1
Bit 5	24, 25	DIF_5	Output Control	RW	Hi-Z	Enable	1
Bit 4	19,20	DIF_4	Output Control	RW	Hi-Z	Enable	1
Bit 3	16,17	DIF_3	Output Control	RW	Hi-Z	Enable	1
Bit 2	13,14	DIF_2	Output Control	RW	Hi-Z	Enable	1
Bit 1	9,10	DIF_1	Output Control	RW	Hi-Z	Enable	1
Bit 0	6,7	DIF_0	Output Control	RW	Hi-Z	Enable	1

SMBusTable: Output and PLL BW Control Register

Byte 2	Pin #	Name	Control Function	Type	0	1	PWD
Bit 7		Reserved					1
Bit 6	see note	PLL_BW# adjust		RW	High BW	Low BW	1
Bit 5	see note	BYPASS# test mode / PLL		RW	Bypass	PLL	1
Bit 4		Reserved					1
Bit 3	51,52	DIF_11	Output Control	RW	Hi-Z	Enable	1
Bit 2	47,48	DIF_10	Output Control	RW	Hi-Z	Enable	1
Bit 1	42,43	DIF_9	Output Control	RW	Hi-Z	Enable	1
Bit 0	39,40	DIF_8	Output Control	RW	Hi-Z	Enable	1

Note: Bit 6 is wired OR to the pin 1 input, any 0 selects High BW

Note: Bit 5 is wired OR to the pin 30 input, any 0 selects Fanout Bypass mode

SMBusTable: Output Enable Readback Register

Byte 3	Pin #	Name	Control Function	Type	0	1	PWD
Bit 7	34	Readback - OE7# Input		R	Readback		X
Bit 6	31	Readback - OE6# Input		R	Readback		X
Bit 5	26	Readback - OE5# Input		R	Readback		X
Bit 4	21	Readback - OE4# Input		R	Readback		X
Bit 3	18	Readback - OE3# Input		R	Readback		X
Bit 2	15	Readback - OE2# Input		R	Readback		X
Bit 1	8	Readback - OE1# Input		R	Readback		X
Bit 0	5	Readback - OE0# Input		R	Readback		X

SMBusTable: Output Enable Readback Register

Byte 4	Pin #	Name	Control Function	Type	0	1	PWD
Bit 7	46	Readback - FS_A_410		R	Readback		X
Bit 6	1	Readback - HIGH_BW# In		R	Readback		X
Bit 5	30	Readback - SMB_A2_PLLBYP# In		R	Readback		X
Bit 4		Reserved		R	Readback		X
Bit 3		Reserved		R	Readback		X
Bit 2	53	Readback - OE10_11# Input		R	Readback		X
Bit 1	44	Readback - OE9# Input		R	Readback		X
Bit 0	41	Readback - OE8# Input		R	Readback		X

SMBusTable: Vendor & Revision ID Register

Byte 5	Pin #	Name	Control Function	Type	0	1	PWD
Bit 7	-	RID3	REVISION ID	R	-	-	X
Bit 6	-	RID2		R	-	-	X
Bit 5	-	RID1		R	-	-	X
Bit 4	-	RID0		R	-	-	X
Bit 3	-	VID3	VENDOR ID	R	-	-	0
Bit 2	-	VID2		R	-	-	0
Bit 1	-	VID1		R	-	-	0
Bit 0	-	VID0		R	-	-	1

SMBusTable: DEVICE ID

Byte 6	Pin #	Name	Control Function	Type	0	1	PWD
Bit 7	-	Device ID 7 (MSB)		RW	Reserved		1
Bit 6	-	Device ID 6		RW	Reserved		1
Bit 5	-	Device ID 5		RW	Reserved		0
Bit 4	-	Device ID 4		RW	Reserved		0
Bit 3	-	Device ID 3		RW	Reserved		0
Bit 2	-	Device ID 2		RW	Reserved		0
Bit 1	-	Device ID 1		RW	Reserved		0
Bit 0	-	Device ID 0		RW	Reserved		1

SMBusTable: Byte Count Register

Byte 7	Pin #	Name	Control Function	Type	0	1	PWD
Bit 7	-	BC7	Writing to this register configures how many bytes will be read back.	RW	-	-	0
Bit 6	-	BC6		RW	-	-	0
Bit 5	-	BC5		RW	-	-	0
Bit 4	-	BC4		RW	-	-	0
Bit 3	-	BC3		RW	-	-	1
Bit 2	-	BC2		RW	-	-	0
Bit 1	-	BC1		RW	-	-	0
Bit 0	-	BC0		RW	-	-	1

SMBusTable: 1:1 PLL Frequency Selection

Byte 8	Pin #	Name	Control Function	Type	0	1	PWD
Bit 7			RESERVED				0
Bit 6			RESERVED				0
Bit 5			RESERVED				0
Bit 4			RESERVED				0
Bit 3			RESERVED				0
Bit 2	-	Frequency Select C		RW	See 9FG1201H 1:1 PLL Programming Table		x
Bit 1	-	Frequency Select B		RW			1
Bit 0	-	FS A 410		RW			Latch

SMBusTable: Reserved Register

Byte 9	Pin #	Name	Control Function	Type	0	1	PWD
Bit 7			RESERVED				0
Bit 6			RESERVED				0
Bit 5			RESERVED				0
Bit 4			RESERVED				0
Bit 3			RESERVED				0
Bit 2			RESERVED				0
Bit 1			RESERVED				0
Bit 0			RESERVED				0

SMBus Table: M/N Programming Enable

Byte 10	Pin #	Name	Control Function	Type	0	1	PWD
Bit 7	-	M/N_EN	Gear PLL and 1:1 PLL M/N Programming Enable	RW	Disable	Enable	0
Bit 6			RESERVED				X
Bit 5			RESERVED				X
Bit 4			RESERVED				X
Bit 3			RESERVED				X
Bit 2			RESERVED				X
Bit 1			RESERVED				X
Bit 0			RESERVED				X

SMBus Table: Gear PLL Frequency Control Register

Byte 11	Pin #	Name	Control Function	Type	0	1	PWD
Bit 7			RESERVED				X
Bit 6			RESERVED				X
Bit 5	-	Gear PLL M Div5	M Divider Programming bits	RW	See 9FG1201H M/N programming Table		X
Bit 4	-	Gear PLL M Div4		RW			X
Bit 3	-	Gear PLL M Div3		RW			X
Bit 2	-	Gear PLL M Div2		RW			X
Bit 1	-	Gear PLL M Div1		RW			X
Bit 0	-	Gear PLL M Div0		RW			X

SMBus Table: Gear PLL Frequency Control Register

Byte 12	Pin #	Name	Control Function	Type	0	1	PWD
Bit 7	-	Gear PLL N Div7	N Divider Programming bits	RW	See 9FG1201H M/N programming Table		X
Bit 6	-	Gear PLL N Div6		RW			X
Bit 5	-	Gear PLL N Div5		RW			X
Bit 4	-	Gear PLL N Div4		RW			X
Bit 3	-	Gear PLL N Div3		RW			X
Bit 2	-	Gear PLL N Div2		RW			X
Bit 1	-	Gear PLL N Div1		RW			X
Bit 0	-	Gear PLL N Div0		RW			X

SMBusTable: Gear PLL Output Divider Register

Byte 13	Pin #	Name	Control Function	Type	0	1	PWD
Bit 7			RESERVED				0
Bit 6			RESERVED				0
Bit 5			RESERVED				0
Bit 4			RESERVED				0
Bit 3		GoutDiv 3	Gear Output Divider	RW	See Gear Output Divider Table		X
Bit 2		GoutDiv 2		RW			X
Bit 1		GoutDiv 1		RW			X
Bit 0		GoutDiv 1		RW			X

SMBusTable: Reserved Register

Byte 14	Pin #	Name	Control Function	Type	0	1	PWD
Bit 7			RESERVED				0
Bit 6			RESERVED				0
Bit 5			RESERVED				0
Bit 4			RESERVED				0
Bit 3			RESERVED				0
Bit 2			RESERVED				0
Bit 1			RESERVED				0
Bit 0			RESERVED				0

SMBusTable: Reserved Register

Byte 15	Pin #	Name	Control Function	Type	0	1	PWD
Bit 7			RESERVED				0
Bit 6			RESERVED				0
Bit 5			RESERVED				0
Bit 4			RESERVED				0
Bit 3			RESERVED				0
Bit 2			RESERVED				0
Bit 1			RESERVED				0
Bit 0			RESERVED				0

SMBusTable: Reserved Register

Byte 16	Pin #	Name	Control Function	Type	0	1	PWD
Bit 7			RESERVED				0
Bit 6			RESERVED				0
Bit 5			RESERVED				0
Bit 4			RESERVED				0
Bit 3			RESERVED				0
Bit 2			RESERVED				0
Bit 1			RESERVED				0
Bit 0			RESERVED				0

SMBus Table: 1:1 PLL Frequency Control Register

Byte 17	Pin #	Name	Control Function	Type	0	1	PWD
Bit 7			RESERVED				0
Bit 6			RESERVED				0
Bit 5	-	1:1 PLL M Div5	M Divider Programming bits	RW	See 9FG1201H M/N programming Table		X
Bit 4	-	1:1 PLL M Div4		RW			X
Bit 3	-	1:1 PLL M Div3		RW			X
Bit 2	-	1:1 PLL M Div2		RW			X
Bit 1	-	1:1 PLL M Div1		RW			X
Bit 0	-	1:1 PLL M Div0		RW			X

SMBus Table: 1:1 PLL Frequency Control Register

Byte 18	Pin #	Name	Control Function	Type	0	1	PWD
Bit 7	-	1:1 PLL N Div7	N Divider Programming bits	RW	See 9FG1201H M/N programming Table		X
Bit 6	-	1:1 PLL N Div6		RW			X
Bit 5	-	1:1 PLL N Div5		RW			X
Bit 4	-	1:1 PLL N Div4		RW			X
Bit 3	-	1:1 PLL N Div3		RW			X
Bit 2	-	1:1 PLL N Div2		RW			X
Bit 1	-	1:1 PLL N Div1		RW			X
Bit 0	-	1:1 PLL N Div0		RW			X

SMBusTable: 1:1 PLL Output Divider Register

Byte 19	Pin #	Name	Control Function	Type	0	1	PWD
Bit 7			RESERVED				0
Bit 6			RESERVED				0
Bit 5			RESERVED				0
Bit 4			RESERVED				0
Bit 3		1outDiv 3	1:1 Output Divider	RW	See 1:1 Output Divider Table		X
Bit 2		1outDiv 2		RW			X
Bit 1		1outDiv 1		RW			X
Bit 0		1outDiv 1		RW			X

SMBusTable: Reserved Register

Byte 20	Pin #	Name	Control Function	Type	0	1	PWD
Bit 7			RESERVED				0
Bit 6			RESERVED				0
Bit 5			RESERVED				0
Bit 4			RESERVED				0
Bit 3			RESERVED				0
Bit 2			RESERVED				0
Bit 1			RESERVED				0
Bit 0			RESERVED				0

SMBusTable: Test Byte Register

Byte 21	Test	Test Function	Type	Test Result	PWD
Bit 7		ICS ONLY TEST	RW	Reserved	0
Bit 6		ICS ONLY TEST	RW	Reserved	0
Bit 5		ICS ONLY TEST	RW	Reserved	0
Bit 4		ICS ONLY TEST	RW	Reserved	0
Bit 3		ICS ONLY TEST	RW	Reserved	0
Bit 2		ICS ONLY TEST	RW	Reserved	0
Bit 1		ICS ONLY TEST	RW	Reserved	0
Bit 0		ICS ONLY TEST	RW	Reserved	0

Note: Do NOT write to Bit 21. Erratic device operation will result!

Absolute Max

PARAMETER	SYMBOL	CONDITIONS	MIN	TYP	MAX	UNITS	Notes
3.3V Core Supply Voltage	VDD_A		GND - 0.5		V _{DD} + 0.5V	V	1
3.3V Logic Supply Voltage	VDD_In		GND - 0.5		V _{DD} + 0.5V	V	1
Storage Temperature	T _s		-65		150	°C	1
Ambient Operating Temp	T _{ambient}		0		70	°C	1
Case Temperature	T _{case}				115	°C	1
Input ESD protection	ESD prot	Human Body Model	2000			V	1

Electrical Characteristics - Input/Supply/Common Output Parameters

T_A = 0 - 70°C; Supply Voltage V_{DD} = 3.3 V +/-5%

PARAMETER	SYMBOL	CONDITIONS	MIN	TYP	MAX	UNITS	Notes
Input High Voltage	V _{IH}	3.3 V +/-5%, Except CLK_IN	2		V _{DD} + 0.3	V	1
Input Low Voltage	V _{IL}	3.3 V +/-5%, Except CLK_IN	V _{SS} - 0.3		0.8	V	1
Input High Current	I _{IH}	V _{IN} = V _{DD}	-5		5	uA	
Input Low Current	I _{IL1}	V _{IN} = 0 V; Inputs with no pull-up resistors	-5			uA	
Low Threshold Input-High Voltage	V _{IH_FS}	3.3 V +/-5%, Applies to FS_A_410 pin	0.7		V _{DD} + 0.3	V	1
Low Threshold Input-Low Voltage	V _{IL_FS}	3.3 V +/-5%, Applies to FS_A_410 pin	V _{SS} - 0.3		0.35	V	1
Operating Current	I _{DD3.3OP}	all outputs driven			375	mA	1
Powerdown Current	I _{DD3.3PD}	all differential pairs tri-stated			24	mA	1
Input Frequency	F _i	V _{DD} = 3.3 V	100		400	MHz	3
Pin Inductance	L _{pin}				7	nH	1
Input Capacitance	C _{IN}	Logic Inputs			5	pF	1
	C _{OUT}	Output pin capacitance			5	pF	1
Clk Stabilization	T _{STAB}	From V _{DD} Power-Up or de-assertion of PD# to 1st clock			1.8	ms	1
Modulation Frequency		Triangular Modulation	30		33	kHz	1
Tdrive_PD#		DIF output enable after PD# de-assertion			300	us	1
Tfall_Pd#		PD# fall time of			5	ns	1
Trise_Pd#		PD# rise time of			5	ns	2
SMBus Voltage	V _{MAX}	Maximum input voltage			5.5	V	1
Low-level Output Voltage	V _{OL}	@ I _{PULLUP}			0.4	V	1
Current sinking at V _{OL} = 0.4 V	I _{PULLUP}		4			mA	1
SCLK/SDATA Clock/Data Rise Time	T _{RI2C}	(Max V _{IL} - 0.15) to (Min V _{IH} + 0.15)			1000	ns	1
SCLK/SDATA Clock/Data Fall Time	T _{FI2C}	(Min V _{IH} + 0.15) to (Max V _{IL} - 0.15)			300	ns	1

Electrical Characteristics - DIF 0.7V Current Mode Differential Pair

$T_A = 0 - 70^\circ\text{C}$; $V_{DD} = 3.3\text{ V } \pm 5\%$; $C_L = 2\text{pF}$, $R_S = 33.2\Omega$, $R_P = 49.9\Omega$, $I_{REF} = 475\Omega$

PARAMETER	SYMBOL	CONDITIONS	MIN	TYP	MAX	UNITS	NOTES
Current Source Output Impedance	Z_o^1	$V_o = V_x$	3000			Ω	1
Voltage High	VHigh	Statistical measurement on single ended signal using oscilloscope math function.	660		850	mV	1,3
Voltage Low	VLow		-150		150		1,3
Max Voltage	Vovs	Measurement on single ended signal using absolute value.			1150	mV	1
Min Voltage	Vuds		-300				1
Crossing Voltage (abs)	Vcross(abs)		250		550	mV	1
Crossing Voltage (var)	d-Vcross	Variation of crossing over all edges			140	mV	1
Long Accuracy	ppm	see Tperiod min-max values	-300		300	ppm	1,2
Average period	Tperiod	400MHz nominal	2.4993		2.5008	ns	2
		400MHz spread	2.4993		2.5133	ns	2
		333.33MHz nominal	2.9991		3.0009	ns	2
		333.33MHz spread	2.9991		3.016	ns	2
		266.66MHz nominal	3.7489		3.7511	ns	2
		266.66MHz spread	3.7489		3.77	ns	2
		200MHz nominal	4.9985		5.0015	ns	2
		200MHz spread	4.9985		5.0266	ns	2
		166.66MHz nominal	5.9982		6.0018	ns	2
		166.66MHz spread	5.9982		6.0320	ns	2
		133.33MHz nominal	7.4978		7.5023	ns	2
		133.33MHz spread	7.4978		7.5400	ns	2
		100.00MHz nominal	9.9970		10.0030	ns	2
		100.00MHz spread	9.9970		10.0533	ns	2
Absolute min period	T _{absmin}	400MHz nominal/spread	2.4143			ns	1,2
		333.33MHz nominal/spread	2.9141			ns	1,2
		266.66MHz nominal/spread	3.6639			ns	1,2
		200MHz nominal/spread	4.8735			ns	1,2
		166.66MHz nominal/spread	5.8732			ns	1,2
		133.33MHz nominal/spread	7.3728			ns	1,2
		100.00MHz nominal/spread	9.8720			ns	1,2
Rise Time	t_r	$V_{OL} = 0.175\text{V}$, $V_{OH} = 0.525\text{V}$	175		700	ps	1
Fall Time	t_f	$V_{OH} = 0.525\text{V}$, $V_{OL} = 0.175\text{V}$	175		700	ps	1
Rise Time Variation	d- t_r				125	ps	1
Fall Time Variation	d- t_f				125	ps	1
Duty Cycle	d_{13}	Measurement from differential waveform	45		55	%	1
Jitter, Cycle to cycle	$t_{JCYC-CYC}$	PLL mode, from differential waveform			50	ps	1,4,5
	t_{JBYP}	Bypass mode as additive jitter			50	ps	1,4

Notes:

1. Guaranteed by design and characterization, not 100% tested in production.
2. All Long Term Accuracy and Clock Period specifications are guaranteed assuming that the input frequency meets CK410B accuracy requirements
3. $I_{REF} = V_{DD}/(3 \times RR)$. For $RR = 475\Omega$ (1%), $I_{REF} = 2.32\text{mA}$. $I_{OH} = 6 \times I_{REF}$ and $V_{OH} = 0.7\text{V}$ @ $Z_O = 50\Omega$.
4. Measured into fixed 2 pF load cap. Input to output skew is measured at the first output edge following the corresponding input.
5. Measured from differential cross-point to differential cross-point
6. All Bypass Mode Input-to-Output specs refer to the timing between an input edge and the specific output edge created by it.

Electrical Characteristics - Skew and Differential Jitter Parameters

T_A = 0 - 70°C; Supply Voltage V_{DD} = 3.3 V +/-5%

Group	Parameter	Description	Min	Typ	Max	Units	Notes
CLK_IN, DIF[x:0]	t _{SPO_PLL}	Input-to-Output Skew in PLL mode (1:1 only), nominal value @ 25°C, 3.3V	-500	140	500	ps	1,2,4,5,8,12
CLK_IN, DIF[x:0]	t _{PD_BYP}	Input-to-Output Skew in Bypass mode (1:1 only), nominal value @ 25°C, 3.3V	2.5	3.1	4.5	ns	1,2,3,5,12
CLK_IN, DIF [x:0]	Δt _{SPO_PLL}	Input-to-Output Skew Variation in PLL mode (over specified voltage / temperature operating ranges)		270	350	ps	1,2,4,5,6,10,12
CLK_IN, DIF [x:0]	Δt _{PD_BYP}	Input-to-Output Skew Variation in Bypass mode (over specified voltage / temperature operating ranges)		470	500	ps	1,2,3,4,5,6,10,12
DIF[11:10]	t _{SKEW_G2}	Output-to-Output Skew Group of 2 (Common to Bypass and PLL mode)		10	25	ps	1,2,12
DIF[9:0]	t _{SKEW_G10}	Output-to-Output Skew Group of 10 (Common to Bypass and PLL mode)		40	50	ps	1,2,12
DIF[11:0]	t _{SKEW_A12}	Output-to-Output Skew across all 12 outputs (Common to Bypass and PLL mode - all outputs at same gear)		80	100	ps	1,2,3,12
DIF[11:0]	t _{JPH}	Differential Phase Jitter (RMS Value)		5	10	ps	1,4,7,12
DIF[11:0]	t _{SSTERROR}	Differential Spread Spectrum Tracking Error (peak to peak)		40	80	ps	1,4,9,12
PLL Jitter Peaking	j _{peak-hibw}	(HIGH_BW# = 0)	0	2	2.5	dB	11,12
PLL Jitter Peaking	j _{peak-lobw}	(HIGH_BW# = 1)	0	1.3	2	dB	11,12
PLL Bandwidth	pll _{HIBW}	(HIGH_BW# = 0)	2	3.6	4	MHz	12,13
PLL Bandwidth	pll _{LOBW}	(HIGH_BW# = 1)	0.7	1.2	1.4	MHz	12,13

NOTES on Skew and Differential Jitter Parameters:

1. Measured into fixed 2 pF load cap. Input to output skew is measured at the first output edge following the corresponding input.
2. Measured from differential cross-point to differential cross-point
3. All Bypass Mode Input-to-Output specs refer to the timing between an input edge and the specific output edge created by it.
4. This parameter is deterministic for a given device
5. Measured with scope averaging on to find mean value.
6. Long-term variation from nominal of input-to-output skew over temperature and voltage for a single device.
7. This parameter is measured at the outputs of two separate 9FG1201H devices driven by a single CK410B+. The 9FG1201H must be set to high bandwidth. Differential phase jitter is the accumulation of the phase jitter not shared by the outputs (eg. not including the affects of spread spectrum). Target ranges of consideration are agents with BW of 1-22MHz and 11-33MHz.
8. t is the period of the input clock
9. Differential spread spectrum tracking error is the difference in spread spectrum tracking between two 9FG1201H devices. This parameter is measured at the outputs of two separate 9FG1201H devices driven by a single CK410B+ in Spread Spectrum mode. The 9FG1201H must set to high bandwidth. The spread spectrum characteristics are : maximum of 0.5%, 30 to 33KHz modulation frequency, linear profile.
10. This parameter is an absolute value. It is not a double-sided figure.
11. Measured as maximum pass band gain. At frequencies within the loop BW, highest point of magnification is called PLL jitter peaking.
12. Guaranteed by design and characterization, not 100% tested in production.
13. Measured at 3 db down or half power point.

Electrical Characteristics - Phase Jitter

PARAMETER	SYMBOL	CONDITIONS	MIN	TYP.	MAX	UNITS	NOTES
Jitter, Phase	$t_{jphPCle1}$	PCIe Gen 1 REFCLK phase jitter (including PLL BW 8 - 16 MHz, $\zeta = 0.54$, Td=10 ns, Ftrk=1.5 MHz)		40/38	86	ps	1,2,3,5
	$t_{jphPCle2Lo}$	PCIe Gen 2 REFCLK phase jitter (including PLL BW 8 - 16 MHz, $\zeta = 0.54$, Td=12 ns) Lo-band content (10kHz to 1.5MHz)		1.3/1.2	3	ps rms	1,2,5
	$t_{jphPCle2Hi}$	PCIe Gen 2 REFCLK phase jitter (including PLL BW 8 - 16 MHz, $\zeta = 0.54$, Td=12 ns) Hi-band content (1.5MHz to Nyquist)		3.0/2.4	3.1	ps rms	1,2,5
	$t_{jphFBD1_3.2G}$	FBD REFCLK phase jitter (including PLL BW 11 - 33 MHz, $\zeta = 0.54$, Td=12 ns Ftrl=0.2MHz)		2.8/2.3	3	ps (RMS)	1,2,5
	$t_{jphFBD1_4.8G}$	FBD REFCLK phase jitter (including PLL BW 11 - 33 MHz, $\zeta = 0.54$, Td=12 ns Ftrl=0.2MHz)		2.3/1.9	2.5	ps (RMS)	1,2,5

Notes on Phase Jitter:

- ¹ See <http://www.pcisig.com> for complete specs. Guaranteed by design and characterization, not tested in production.
- ² Device driven by 932S421BGLF or equivalent
- ³ Sample size of at least 100K cycles. This figures extrapolates to 108ps pk-pk @ 1M cycles for a BER of 10^{-12}
- ⁴ Hi-Bandwidth Number/Low Bandwidth Number with Spread On. Spread Off gives lower numbers.
- ⁵ Byte 8 must be properly set to meet these parameters.

SRC Reference Clock			
Common Recommendations for Differential Routing	Dimension or Value	Unit	Figure
L1 length, route as non-coupled 50ohm trace	0.5 max	inch	1
L2 length, route as non-coupled 50ohm trace	0.2 max	inch	1
L3 length, route as non-coupled 50ohm trace	0.2 max	inch	1
Rs	33	ohm	1
Rt	49.9	ohm	1

Down Device Differential Routing			
L4 length, route as coupled microstrip 100ohm differential trace	2 min to 16 max	inch	1
L4 length, route as coupled stripline 100ohm differential trace	1.8 min to 14.4 max	inch	1

Differential Routing to PCI Express Connector			
L4 length, route as coupled microstrip 100ohm differential trace	0.25 to 14 max	inch	2
L4 length, route as coupled stripline 100ohm differential trace	0.225 min to 12.6 max	inch	2

Figure 1: Down Device Routing

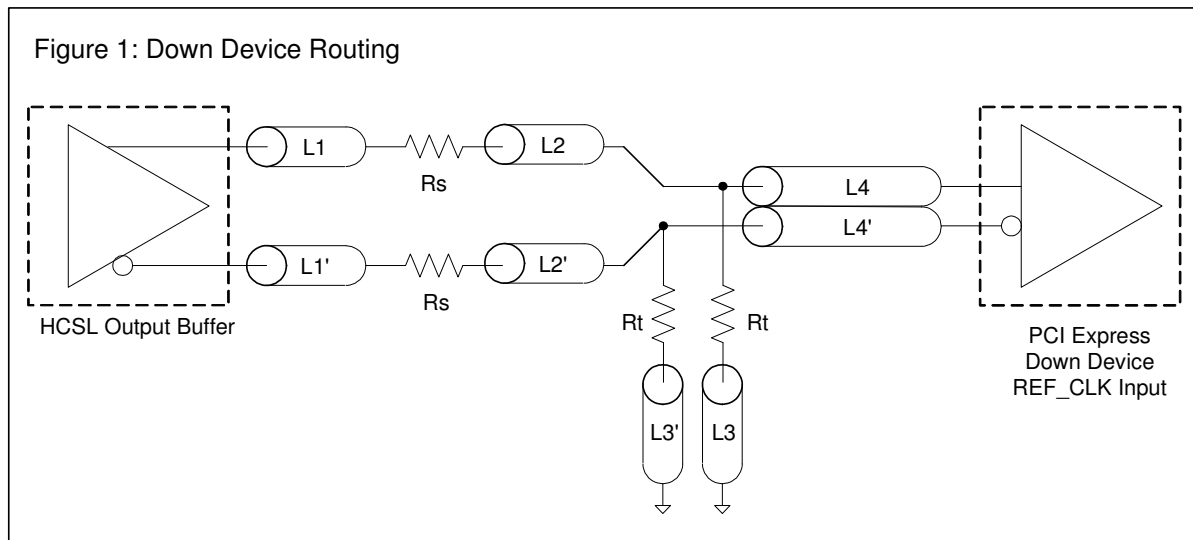
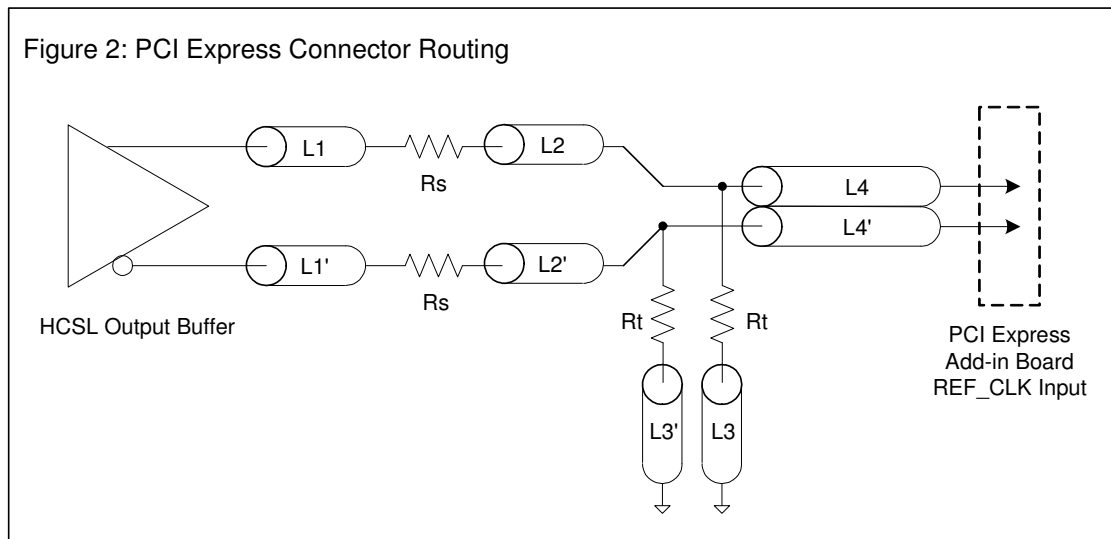
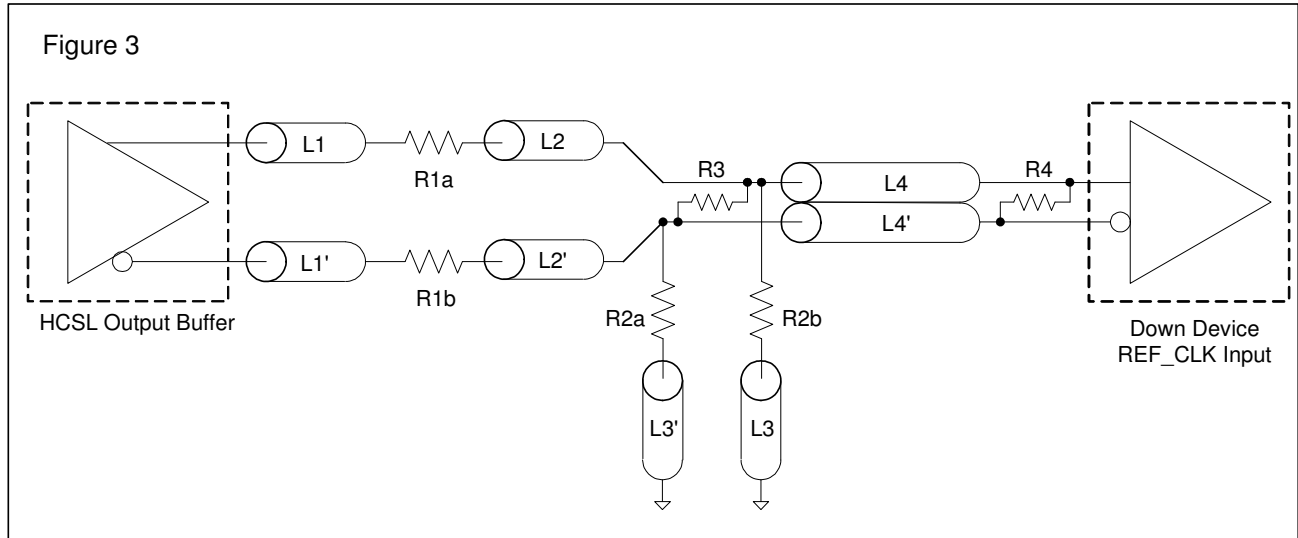

Figure 2: PCI Express Connector Routing



Alternative Termination for LVDS and other Common Differential Signals (figure 3)							
Vdiff	Vp-p	Vcm	R1	R2	R3	R4	Note
0.45v	0.22v	1.08	33	150	100	100	
0.58	0.28	0.6	33	78.7	137	100	
0.80	0.40	0.6	33	78.7	none	100	ICS874003i-02 input compatible
0.60	0.3	1.2	33	174	140	100	Standard LVDS

R1a = R1b = R1
 R2a = R2b = R2



Cable Connected AC Coupled Application (figure 4)		
Component	Value	Note
R5a, R5b	8.2K 5%	
R6a, R6b	1K 5%	
Cc	0.1 μ F	
Vcm	0.350 volts	

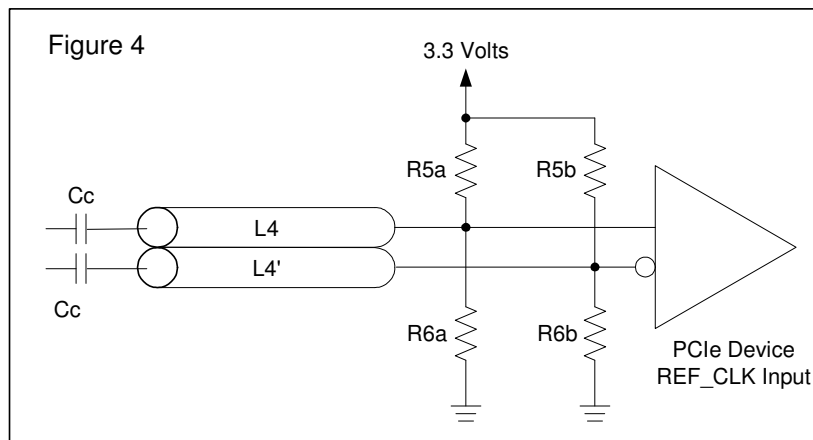

ICS9FG1201H
Frequency Gearing Clock for CPU, PCIe Gen1, Gen2, & FBD

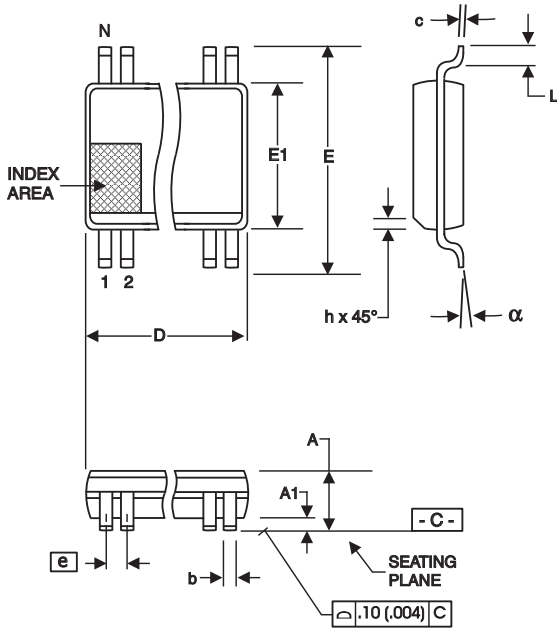

56-Lead, 300 mil Body, 25 mil, SSOP

SYMBOL	In Millimeters COMMON DIMENSIONS		In Inches COMMON DIMENSIONS	
	MIN	MAX	MIN	MAX
A	2.41	2.80	.095	.110
A1	0.20	0.40	.008	.016
b	0.20	0.34	.008	.0135
c	0.13	0.25	.005	.010
D	SEE VARIATIONS		SEE VARIATIONS	
E	10.03	10.68	.395	.420
E1	7.40	7.60	.291	.299
e	0.635 BASIC		0.025 BASIC	
h	0.38	0.64	.015	.025
L	0.50	1.02	.020	.040
N	SEE VARIATIONS		SEE VARIATIONS	
alpha	0°	8°	0°	8°

VARIATIONS

N	D mm.		D (inch)	
	MIN	MAX	MIN	MAX
56	18.31	18.55	.720	.730

Reference Doc.: JEDEC Publication 95, MO-118

10-0034

ICS9FG1201H
Frequency Gearing Clock for CPU, PCIe Gen1, Gen2, & FBD

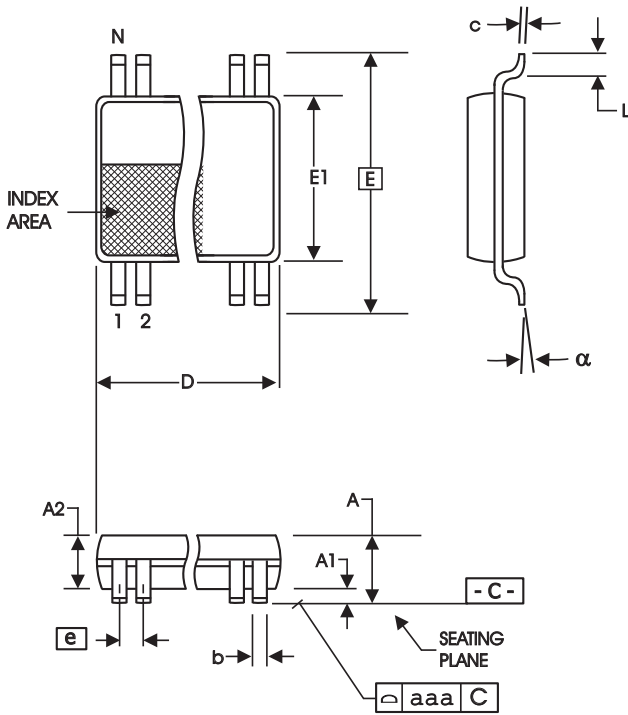

56-Lead 6.10 mm. Body, 0.50 mm. Pitch TSSOP
(240 mil) (20 mil)

SYMBOL	In Millimeters		In Inches	
	COMMON DIMENSIONS	COMMON DIMENSIONS	COMMON DIMENSIONS	COMMON DIMENSIONS
	MIN	MAX	MIN	MAX
A	--	1.20	--	.047
A1	0.05	0.15	.002	.006
A2	0.80	1.05	.032	.041
b	0.17	0.27	.007	.011
c	0.09	0.20	.0035	.008
D	SEE VARIATIONS		SEE VARIATIONS	
E	8.10 BASIC		0.319 BASIC	
E1	6.00	6.20	.236	.244
e	0.50 BASIC		0.020 BASIC	
L	0.45	0.75	.018	.030
N	SEE VARIATIONS		SEE VARIATIONS	
alpha	0°	8°	0°	8°
aaa	--	0.10	--	.004

VARIATIONS

N	D mm.		D (inch)	
	MIN	MAX	MIN	MAX
56	13.90	14.10	.547	.555

Reference Doc.: JEDEC Publication 95, MO-153

10-0039

Ordering Information

Part / Order Number	Shipping/Packaging	Package	Temperature
9FG1201HGLF	Tubes	56-pin TSSOP	0 to +70°C
9FG1201HGLFT	Tape and Reel	56-pin TSSOP	0 to +70°C
9FG1201HFLF	Tubes	56-pin SSOP	0 to +70°C
9FG1201HFLFT	Tape and Reel	56-pin SSOP	0 to +70°C

"LF" denotes Pb free packaging, RoHS compliant

"H" denotes revision designator (will not correlate with datasheet revision)

Revision History

Rev.	Issue Date	Description	Page #
A	10/22/2007	Release to Final.	-
B	1/29/2008	Updated Key Specifications: Changed units for DIF output-to-output skew to "ps".	1
C	2/12/2008	Changed Cin value from 6 pf to 5 pf.	14
D	9/24/2008	Added 1:1 VCO Programming Table	6
E	1/21/2009	Updated Skew and Phase Jitter tables.	17,18
F	9/23/2009	Updated Ordering Information table	22

IMPORTANT NOTICE AND DISCLAIMER

RENESAS ELECTRONICS CORPORATION AND ITS SUBSIDIARIES (“RENESAS”) PROVIDES TECHNICAL SPECIFICATIONS AND RELIABILITY DATA (INCLUDING DATASHEETS), DESIGN RESOURCES (INCLUDING REFERENCE DESIGNS), APPLICATION OR OTHER DESIGN ADVICE, WEB TOOLS, SAFETY INFORMATION, AND OTHER RESOURCES “AS IS” AND WITH ALL FAULTS, AND DISCLAIMS ALL WARRANTIES, EXPRESS OR IMPLIED, INCLUDING, WITHOUT LIMITATION, ANY IMPLIED WARRANTIES OF MERCHANTABILITY, FITNESS FOR A PARTICULAR PURPOSE, OR NON-INFRINGEMENT OF THIRD-PARTY INTELLECTUAL PROPERTY RIGHTS.

These resources are intended for developers who are designing with Renesas products. You are solely responsible for (1) selecting the appropriate products for your application, (2) designing, validating, and testing your application, and (3) ensuring your application meets applicable standards, and any other safety, security, or other requirements. These resources are subject to change without notice. Renesas grants you permission to use these resources only to develop an application that uses Renesas products. Other reproduction or use of these resources is strictly prohibited. No license is granted to any other Renesas intellectual property or to any third-party intellectual property. Renesas disclaims responsibility for, and you will fully indemnify Renesas and its representatives against, any claims, damages, costs, losses, or liabilities arising from your use of these resources. Renesas' products are provided only subject to Renesas' Terms and Conditions of Sale or other applicable terms agreed to in writing. No use of any Renesas resources expands or otherwise alters any applicable warranties or warranty disclaimers for these products.

(Disclaimer Rev.1.01 Jan 2024)

Corporate Headquarters

TOYOSU FORESIA, 3-2-24 Toyosu,
Koto-ku, Tokyo 135-0061, Japan
www.renesas.com

Trademarks

Renesas and the Renesas logo are trademarks of Renesas Electronics Corporation. All trademarks and registered trademarks are the property of their respective owners.

Contact Information

For further information on a product, technology, the most up-to-date version of a document, or your nearest sales office, please visit www.renesas.com/contact-us/.

Looking for pricing, stock, or lifecycle information?

Click below to explore more details on WIN SOURCE:

-  [View 9FG1201HGLFT on WIN SOURCE](#)
-  [Renesas Electronics America](#) Information

Optimize Your Supply Chain with WIN SOURCE Solutions

-  Global Sourcing Solution
-  Obsolete Management
-  Cost Control Management
-  Shortage Management
-  Alternative Solution
-  Excess Inventory Management