



**THE DATASHEET OF
85352AYILF**



General Description

The 85352 is a 12 bit, 2-to-1 LVPECL Clock Buffer. Individual input select controls support independent multiplexer operation from a common clock input source. Clock inputs accept most standard differential levels.

The 85352 is characterized at full 3.3V or mixed 3.3V core/2.5V output operating supply modes.

Features

- Twelve, 2-to-1 multiplexers with LVPECL outputs
- Selectable differential CLKx, nCLKx input pairs
- CLK, nCLK pair can accept the following differential input levels: LVPECL, LVDS, LVHSTL, HCSL, SSTL
- Maximum output frequency: 700MHz
- Individual select control for each multiplexer
- Select inputs accept LVCMOS / LVTTTL levels
- Propagation delay: 2ns (maximum)
- Additive Phase Jitter, RMS: 0.21ps (typical), 3.3V
- Full 3.3V or mixed 3.3V core/2.5V output supply
- -40°C to 85°C ambient operating temperature
- Available in lead-free (RoHS 6) package

Block Diagram

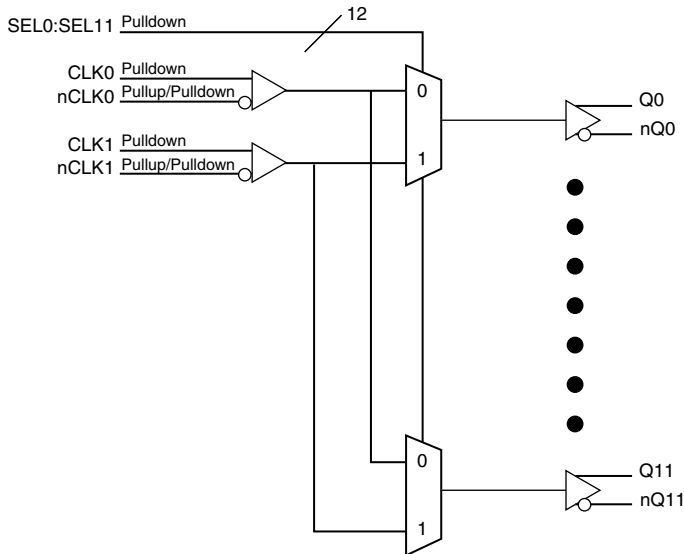

Pin Assignment

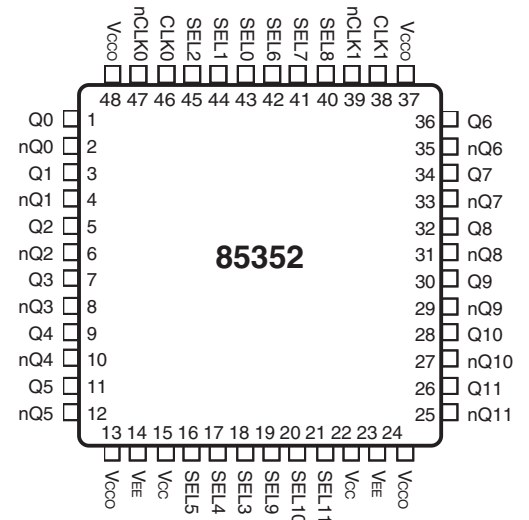

85352

48-Lead TQFP, E-Pad
7mm x 7mm x 1.0mm package body
Y Package
Top View

Pin Description and Pin Characteristic Tables

Table 1. Pin Descriptions

Number	Name	Type		Description
1, 2 3, 4 5, 6 7, 8 9, 10 11, 12 25, 26 27, 28 29, 30 31, 32 33, 34 35, 36	Q0, nQ0 Q1, nQ1 Q2, nQ2 Q3, nQ3 Q4, nQ4 Q5, nQ5 nQ11, Q11 nQ10, Q10 nQ9, Q9 nQ8, Q8 nQ7, Q7 nQ6, Q6	Output		Differential output pairs. LVPECL interface levels.
13, 24, 37, 48	V _{CC0}	Power		Output power supply pins.
14, 23	V _{EE}	Power		Negative power supply pins.
15, 22	V _{CC}	Power		Positive power supply pins.
16, 17, 18, 19, 20, 21, 40, 41, 42, 43, 44, 45	SEL5, SEL4, SEL3, SEL9, SEL10, SEL11, SEL8, SEL7, SEL6, SEL0, SEL1, SEL2	Input	Pulldown	Clock select inputs. LVCMOS / LVTTTL interface levels. See Table 3.
38	CLK1	Input	Pulldown	Non-inverting differential clock input.
39	nCLK1	Input	Pullup/ Pulldown	Inverting differential clock input. V _{CC} /2 default when left floating.
46	CLK0	Input	Pulldown	Non-inverting differential clock input.
47	nCLK0	Input	Pullup/ Pulldown	Inverting differential clock input. V _{CC} /2 default when left floating

NOTE: Pullup and Pulldown refer to internal input resistors. See Table 2, Pin Characteristics, for typical values.

Table 2. Pin Characteristics

Symbol	Parameter	Test Conditions	Minimum	Typical	Maximum	Units
C _{IN}	Input Capacitance			4		pF
R _{PULLUP}	Input Pullup Resistor			51		kΩ
R _{PULLDOWN}	Input Pulldown Resistor			51		kΩ

Function Table

Table 3. Control Input Function Table

SELx	Selected Clock inputs
0	CLK0, nCLK0
1	CLK1, nCLK1

Absolute Maximum Ratings

NOTE: Stresses beyond those listed under *Absolute Maximum Ratings* may cause permanent damage to the device. These ratings are stress specifications only. Functional operation of product at these conditions or any conditions beyond those listed in the *DC Characteristics* or *AC Characteristics* is not implied. Exposure to absolute maximum rating conditions for extended periods may affect product reliability.

Item	Rating
Supply Voltage, V_{CC}	4.6V
Inputs, V_I	-0.5V to $V_{CC} + 0.5V$
Outputs, I_O Continuous Current Surge Current	50mA 100mA
Package Thermal Impedance, θ_{JA}	27.6°C/W (0 lfpm)
Storage Temperature, T_{STG}	-65°C to 150°C

DC Electrical Characteristics

Table 4A. Power Supply DC Characteristics, $V_{CC} = 3.3V \pm 5\%$, $V_{CCO} = 2.5V$ to $3.3V \pm 5\%$, $V_{EE} = 0V$, $T_A = -40^\circ C$ to $85^\circ C$

Symbol	Parameter	Test Conditions	Minimum	Typical	Maximum	Units
V_{CC}	Positive Supply Voltage		3.135	3.3	3.465	V
V_{CCO}	Output Supply Voltage		2.375	3.3	3.465	V
I_{EE}	Power Supply Current				170	mA

Table 4B. LVC MOS/LVTTL DC Characteristics, $V_{CC} = 3.3V \pm 5\%$, $V_{CCO} = 2.5V$ to $3.3V \pm 5\%$, $V_{EE} = 0V$, $T_A = -40^\circ C$ to $85^\circ C$

Symbol	Parameter	Test Conditions	Minimum	Typical	Maximum	Units
V_{IH}	Input High Voltage		2		$V_{CC} + 0.3$	V
V_{IL}	Input Low Voltage		-0.3		0.8	V
I_{IH}	Input High Current	SEL[0:11] $V_{CC} = V_{IN} = 3.465V$			150	μA
I_{IL}	Input Low Current	SEL[0:11] $V_{CC} = 3.465V, V_{IN} = 0V$	-5			μA

Table 4C. Differential Input DC Characteristics, $V_{CC} = 3.3V \pm 5\%$, $V_{CCO} = 2.5V$ to $3.3V \pm 5\%$, $V_{EE} = 0V$, $T_A = -40^\circ C$ to $85^\circ C$

Symbol	Parameter	Test Conditions	Minimum	Typical	Maximum	Units
I_{IH}	Input High Current	CLK0, CLK1			150	μA
		nCLK0, nCLK1			150	μA
I_{IL}	Input Low Current	CLK0, CLK1	-5			μA
		nCLK0, nCLK1	-150			μA
V_{PP}	Peak-to-Peak Input Voltage; NOTE 1		0.15		1.0	V
V_{CMR}	Common Mode Input Voltage; NOTE 1, 2		$V_{EE} + 0.5$		$V_{CC} - 0.85$	V

NOTE 1: V_{IL} should not be less than -0.3V.

NOTE 2: Common mode input voltage is defined as V_{IH} .

Table 4D. LVPECL DC Characteristics, $V_{CC} = 3.3V \pm 5\%$, $V_{CCO} = 2.5V$ to $3.3V \pm 5\%$, $V_{EE} = 0V$, $T_A = -40^\circ C$ to $85^\circ C$

Symbol	Parameter	Test Conditions	Minimum	Typical	Maximum	Units
V_{OH}	Output High Voltage; NOTE 1		$V_{CCO} - 1.4$		$V_{CCO} - 0.9$	V
V_{OL}	Output Low Voltage; NOTE 1		$V_{CCO} - 2.0$		$V_{CCO} - 1.7$	V
V_{SWING}	Peak-to-Peak Output Voltage Swing		0.6		1.0	V

NOTE 1: Outputs terminated with 50Ω to $V_{CCO} - 2V$.

AC Electrical Characteristics

Table 5A. AC Electrical Characteristics, $V_{CC} = V_{CCO} = 3.3V \pm 5\%$, $V_{EE} = 0V$, $T_A = -40^\circ C$ to $85^\circ C$

Symbol	Parameter	Test Conditions	Minimum	Typical	Maximum	Units
f_{MAX}	Output Frequency				700	MHz
t_{PD}	Propagation Delay; NOTE 1		1.0	1.5	2.0	ns
f_{jit}	Buffer Additive Phase Jitter, RMS: refer to additive Phase Jitter Section	156.25MHz Integration Range: (12kHz – 20MHz)		0.21		ps
$t_{sk(o)}$	Output Skew; NOTE 2, 3				180	ps
$t_{sk(pp)}$	Part-to-Part Skew; NOTE 2, 4				750	ps
t_R / t_F	Output Rise/ Fall Time	20% to 80%	150		700	ps
odc	Output Duty Cycle	$f \leq 622MHz$	45		55	%

NOTE: Electrical parameters are guaranteed over the specified ambient operating temperature range, which is established when device is mounted in a test socket with maintained transverse airflow greater than 500 lpm. Device will meet specifications after thermal equilibrium has been reached under these conditions.

NOTE: All parameters measured at f_{MAX} unless noted otherwise.

NOTE 1: Measured from the differential input crossing point to the differential output crossing point.

NOTE 2: This parameter is defined in accordance with JEDEC Standard 65.

NOTE 3: Defined as skew between outputs at the same supply voltage and with equal load conditions. Measured at the differential cross points.

NOTE 4: Defined as skew between outputs on different devices operating at the same supply voltage, same temperature and with equal load conditions. Using the same type of inputs on each device, the outputs are measured at the differential cross points.

Table 5B. AC Electrical Characteristics, $V_{CC} = 3.3V \pm 5\%$, $V_{CCO} = 2.5V \pm 5\%$, $V_{EE} = 0V$, $T_A = -40^\circ C$ to $85^\circ C$

Symbol	Parameter	Test Conditions	Minimum	Typical	Maximum	Units
f_{MAX}	Output Frequency				700	MHz
t_{PD}	Propagation Delay; NOTE 1		1.0	1.5	2.0	ns
f_{jit}	Buffer Additive Phase Jitter, RMS	156.25MHz Integration Range: (12kHz – 20MHz)		0.23		ps
$t_{sk(o)}$	Output Skew; NOTE 2, 3				180	ps
$t_{sk(pp)}$	Part-to-Part Skew; NOTE 2, 4				750	ps
t_R / t_F	Output Rise/ Fall Time	20% to 80%	150		700	ps
odc	Output Duty Cycle	$f \leq 622MHz$	45		55	%

NOTE: Electrical parameters are guaranteed over the specified ambient operating temperature range, which is established when device is mounted in a test socket with maintained transverse airflow greater than 500 lpm. Device will meet specifications after thermal equilibrium has been reached under these conditions.

NOTE: All parameters measured at f_{MAX} unless noted otherwise.

NOTE 1: Measured from the differential input crossing point to the differential output crossing point.

NOTE 2: This parameter is defined in accordance with JEDEC Standard 65.

NOTE 3: Defined as skew between outputs at the same supply voltage and with equal load conditions. Measured at the differential cross points.

NOTE 4: Defined as skew between outputs on different devices operating at the same supply voltage, same temperature and with equal load conditions. Using the same type of inputs on each device, the outputs are measured at the differential cross points.

Additive Phase Jitter

The spectral purity in a band at a specific offset from the fundamental compared to the power of the fundamental is called the **dBc Phase Noise**. This value is normally expressed using a Phase noise plot and is most often the specified plot in many applications. Phase noise is defined as the ratio of the noise power present in a 1Hz band at a specified offset from the fundamental frequency to the power value of the fundamental. This ratio is expressed in decibels (dBm) or a ratio

of the power in the 1Hz band to the power in the fundamental. When the required offset is specified, the phase noise is called a **dBc** value, which simply means dBm at a specified offset from the fundamental. By investigating jitter in the frequency domain, we get a better understanding of its effects on the desired application over the entire time record of the signal. It is mathematically possible to calculate an expected bit error rate given a phase noise plot.

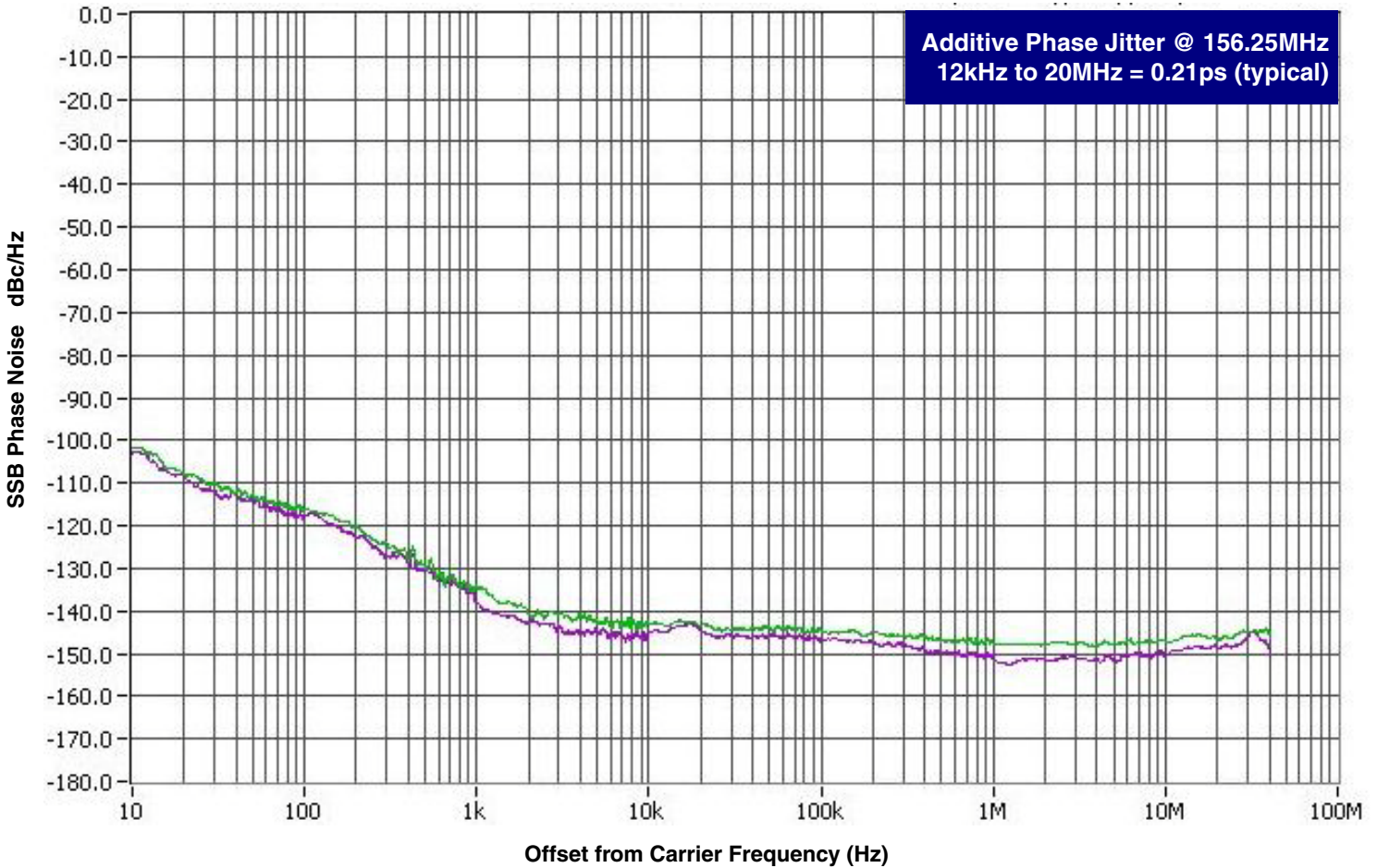

As with most timing specifications, phase noise measurements has issues relating to the limitations of the equipment. Often the noise floor of the equipment is higher than the noise floor of the device. This is illustrated above. The device meets the noise floor of what is shown, but can actually be lower. The phase noise is dependent on the input source and measurement equipment.

The source generator "Rohde & Schwarz Signal Generator SMA100A 9kHz – 6GHz as external input to a Hewlett Packard 8133A 3GHz Pulse Generator".

Parameter Measurement Information

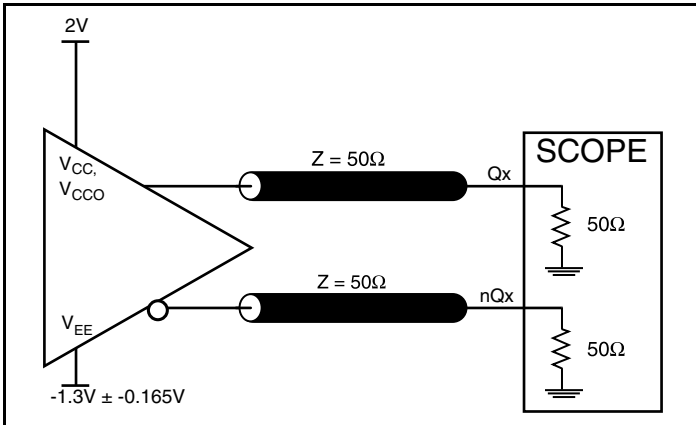

3.3V Core / 3.3V LVPECL Output Load AC Test Circuit

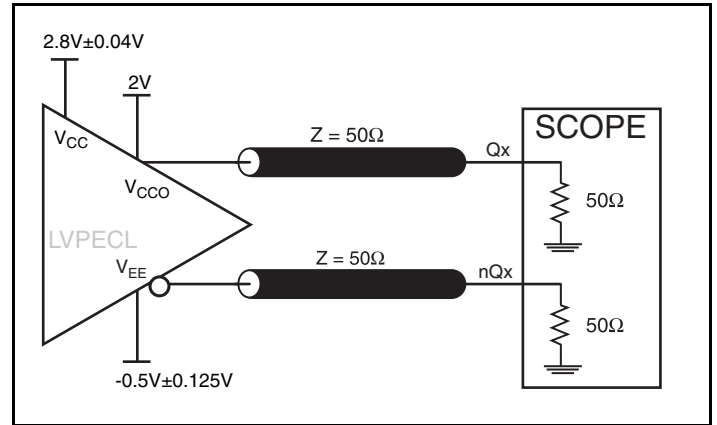

3.3V Core / 2.5V LVPECL Output Load AC Test Circuit

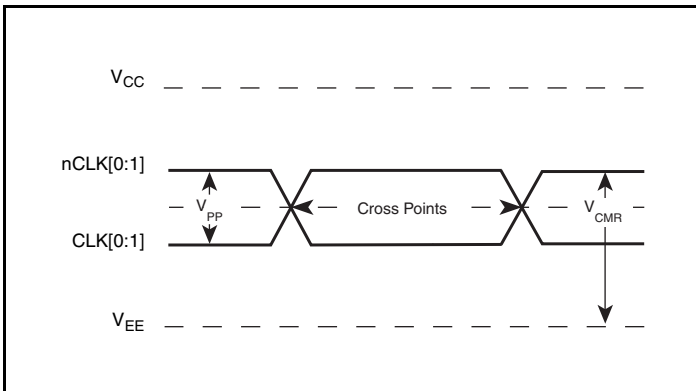

Differential Input Level

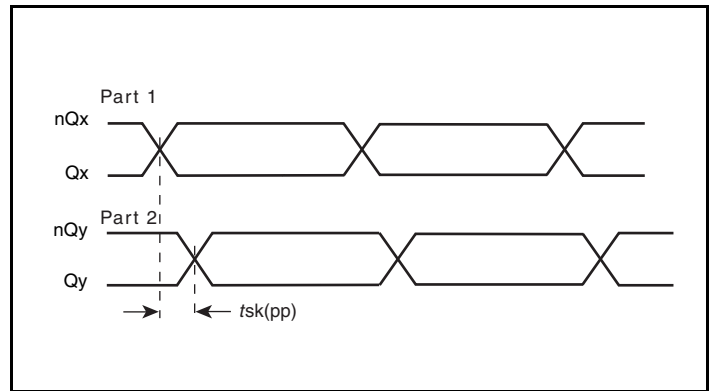

Part-to-Part Skew

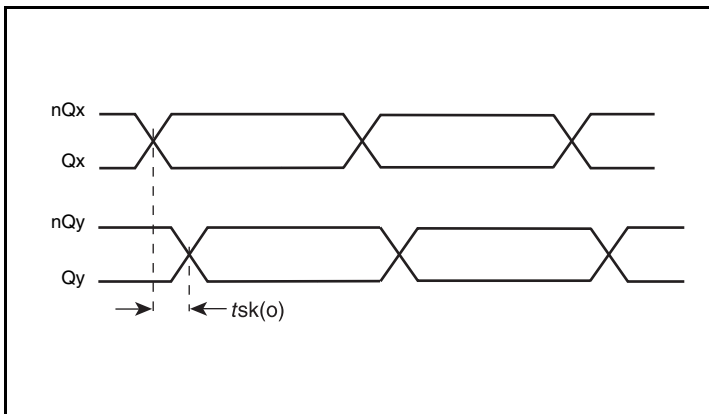

Output Skew

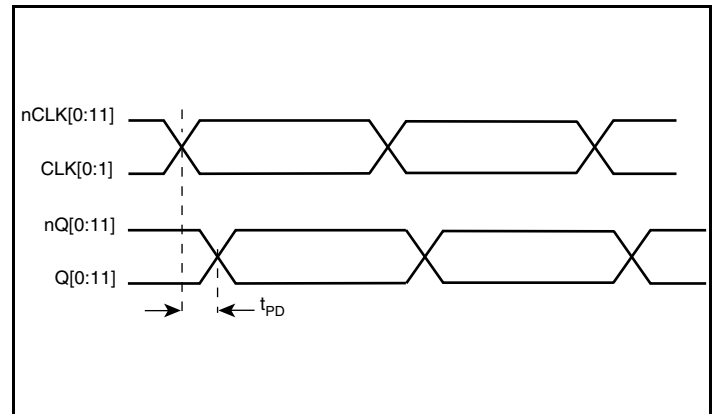

Propagation Delay

Parameter Measurement Information, continued

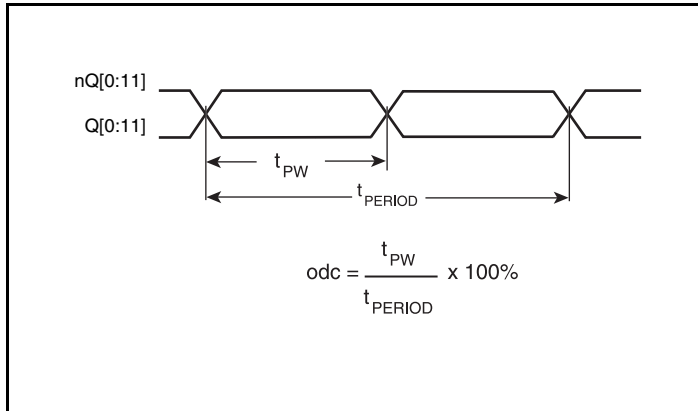

Output Duty Cycle/Pulse Width/Period

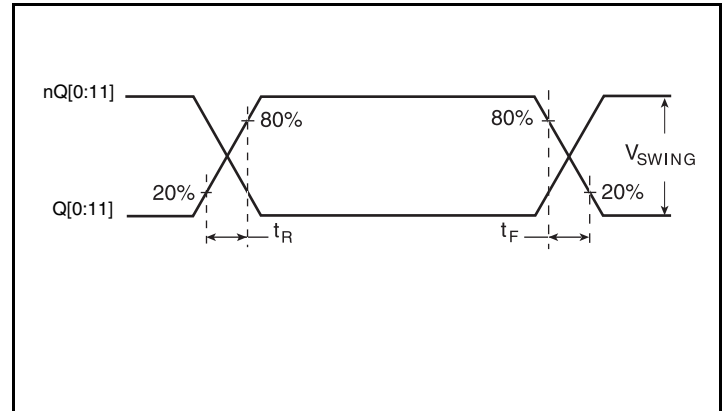

Output Rise/Fall Time

Applications Information

Recommendations for Unused Input and Output Pins

Inputs:

LVCMOS Control Pins

All control pins have internal pullups or pulldowns; additional resistance is not required but can be added for additional protection. A 1k Ω resistor can be used.

CLK/nCLK Inputs

For applications not requiring the use of the differential input, both CLK and nCLK can be left floating. Though not required, but for additional protection, a 1k Ω resistor can be tied from CLK to ground.

Outputs:

LVPECL Outputs

The unused LVPECL output pair can be left floating. We recommend that there is no trace attached. Both sides of the differential output pair should either be left floating or terminated.

Wiring the Differential Input to Accept Single-Ended Levels

Figure 1 shows how a differential input can be wired to accept single ended levels. The reference voltage $V_{REF} = V_{CC}/2$ is generated by the bias resistors R1 and R2. The bypass capacitor (C1) is used to help filter noise on the DC bias. This bias circuit should be located as close to the input pin as possible. The ratio of R1 and R2 might need to be adjusted to position the V_{REF} in the center of the input voltage swing. For example, if the input clock swing is 2.5V and $V_{CC} = 3.3V$, R1 and R2 value should be adjusted to set V_{REF} at 1.25V. The values below are for when both the single ended swing and V_{CC} are at the same voltage. This configuration requires that the sum of the output impedance of the driver (R_o) and the series resistance (R_s) equals the transmission line impedance. In addition, matched termination at the input will attenuate the signal in half. This can be done in one of two ways. First, R3 and R4 in parallel should equal the transmission

line impedance. For most 50Ω applications, R3 and R4 can be 100Ω. The values of the resistors can be increased to reduce the loading for slower and weaker LVCMOS driver. When using single-ended signaling, the noise rejection benefits of differential signaling are reduced. Even though the differential input can handle full rail LVCMOS signaling, it is recommended that the amplitude be reduced. The datasheet specifies a lower differential amplitude, however this only applies to differential signals. For single-ended applications, the swing can be larger, however V_{IL} cannot be less than -0.3V and V_{IH} cannot be more than $V_{CC} + 0.3V$. Though some of the recommended components might not be used, the pads should be placed in the layout. They can be utilized for debugging purposes. The datasheet specifications are characterized and guaranteed by using a differential signal.

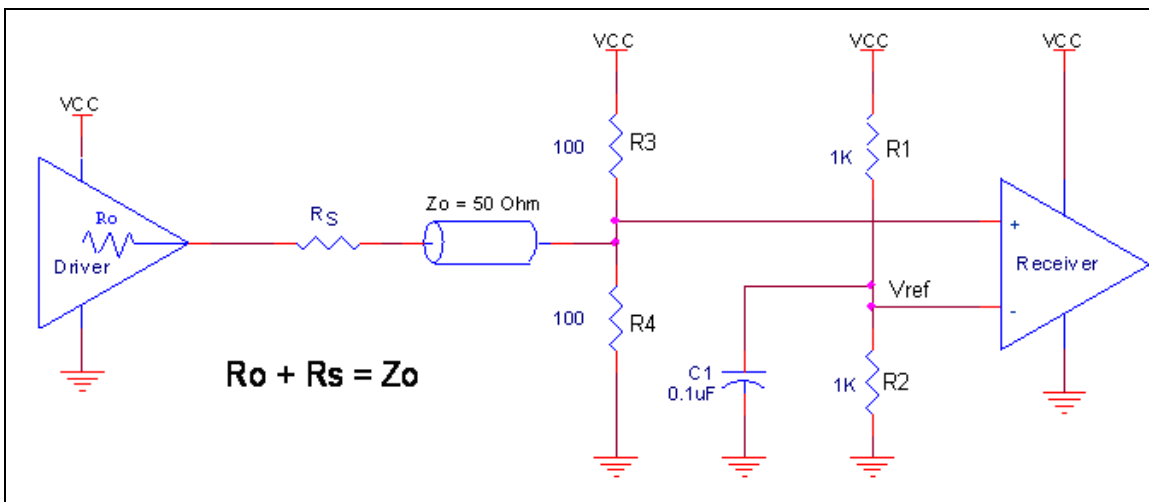

Figure 1. Recommended Schematic for Wiring a Differential Input to Accept Single-ended Levels

EPAD Thermal Release Path

In order to maximize both the removal of heat from the package and the electrical performance, a land pattern must be incorporated on the Printed Circuit Board (PCB) within the footprint of the package corresponding to the exposed metal pad or exposed heat slug on the package, as shown in *Figure 2*. The solderable area on the PCB, as defined by the solder mask, should be at least the same size/shape as the exposed pad/slug area on the package to maximize the thermal/electrical performance. Sufficient clearance should be designed on the PCB between the outer edges of the land pattern and the inner edges of pad pattern for the leads to avoid any shorts.

While the land pattern on the PCB provides a means of heat transfer and electrical grounding from the package to the board through a solder joint, thermal vias are necessary to effectively conduct from the surface of the PCB to the ground plane(s). The land pattern must be connected to ground through these vias. The vias act as “heat pipes”. The number of vias (i.e. “heat pipes”) are application specific

and dependent upon the package power dissipation as well as electrical conductivity requirements. Thus, thermal and electrical analysis and/or testing are recommended to determine the minimum number needed. Maximum thermal and electrical performance is achieved when an array of vias is incorporated in the land pattern. It is recommended to use as many vias connected to ground as possible. It is also recommended that the via diameter should be 12 to 13mils (0.30 to 0.33mm) with 1oz copper via barrel plating. This is desirable to avoid any solder wicking inside the via during the soldering process which may result in voids in solder between the exposed pad/slug and the thermal land. Precautions should be taken to eliminate any solder voids between the exposed heat slug and the land pattern. Note: These recommendations are to be used as a guideline only. For further information, refer to the Application Note on the *Surface Mount Assembly* of Amkor’s Thermally/Electrically Enhance Leadframe Base Package, Amkor Technology.

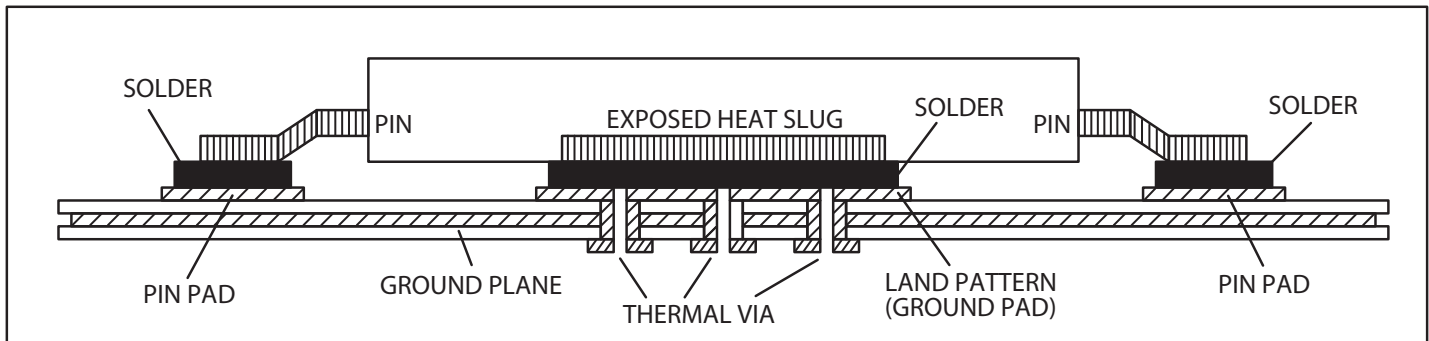

Figure 2. Assembly for Exposed Pad Thermal Release Path - Side View (drawing not to scale)

Differential Clock Input Interface

The CLK /nCLK accepts LVDS, LVPECL, LVHSTL, SSTL, HCSL and other differential signals. Both V_{SWING} and V_{OH} must meet the V_{PP} and V_{CMR} input requirements. Figures 3A to 3F show interface examples for the CLK/nCLK input driven by the most common driver types. The input interfaces suggested here are examples only. Please consult

with the vendor of the driver component to confirm the driver termination requirements. For example in *Figure 3A*, the input termination applies for IDT LVHSTL drivers. If you are using an LVHSTL driver from another vendor, use their termination recommendation.

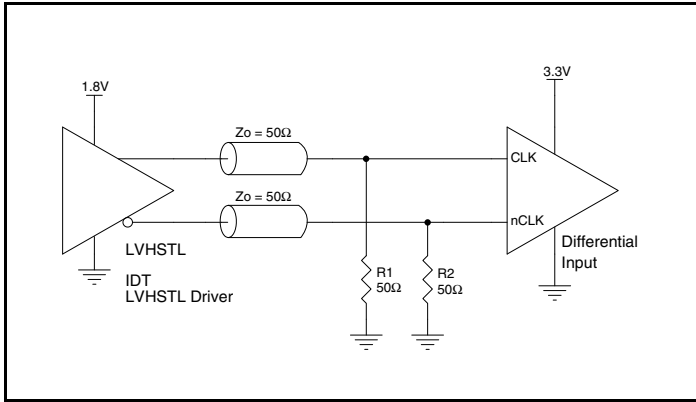

Figure 3A. CLK/nCLK Input Driven by an IDT LVHSTL Driver

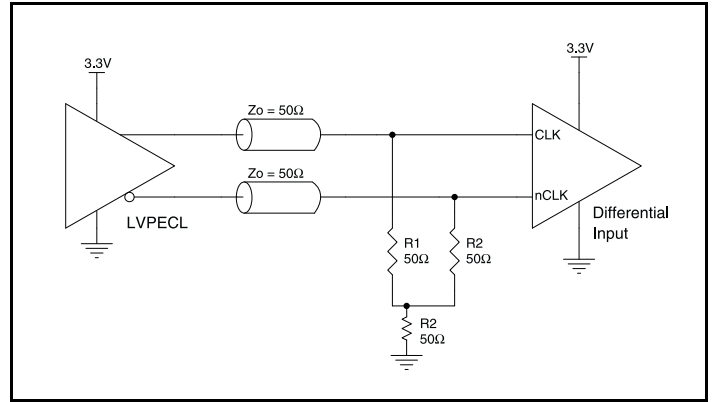

Figure 3B. CLK/nCLK Input Driven by a 3.3V LVPECL Driver

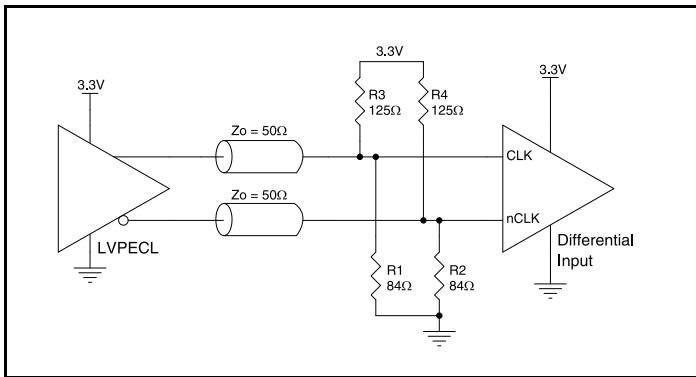

Figure 3C. CLK/nCLK Input Driven by a 3.3V LVPECL Driver

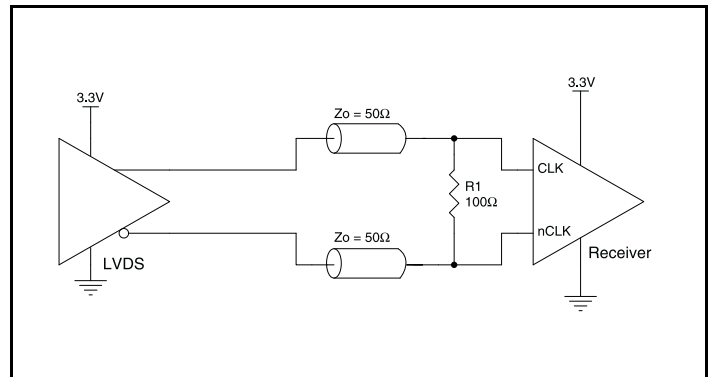

Figure 3D. CLK/nCLK Input Driven by a 3.3V LVDS Driver

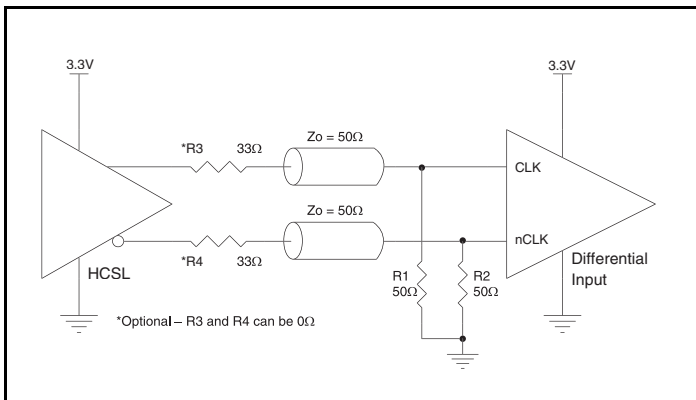

Figure 3E. CLK/nCLK Input Driven by a 3.3V HCSL Driver

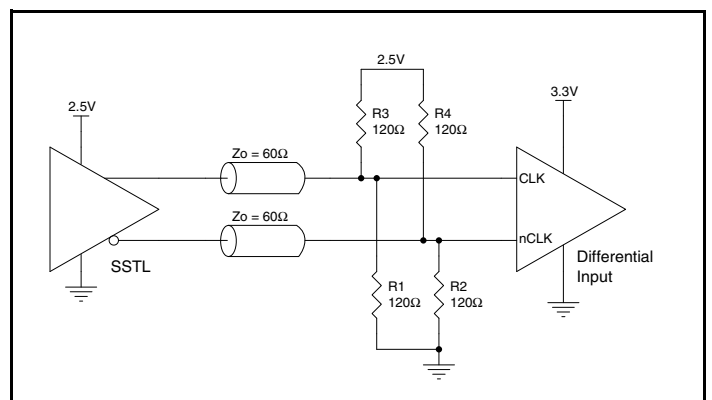

Figure 3F. CLK/nCLK Input Driven by a 2.5V SSTL Driver

Termination for 3.3V LVPECL Outputs

The clock layout topology shown below is a typical termination for LVPECL outputs. The two different layouts mentioned are recommended only as guidelines.

The differential outputs are low impedance follower outputs that generate ECL/LVPECL compatible outputs. Therefore, terminating resistors (DC current path to ground) or current sources must be used for functionality. These outputs are designed to drive 50Ω

transmission lines. Matched impedance techniques should be used to maximize operating frequency and minimize signal distortion.

Figures 4A and 4B show two different layouts which are recommended only as guidelines. Other suitable clock layouts may exist and it would be recommended that the board designers simulate to guarantee compatibility across all printed circuit and clock component process variations.

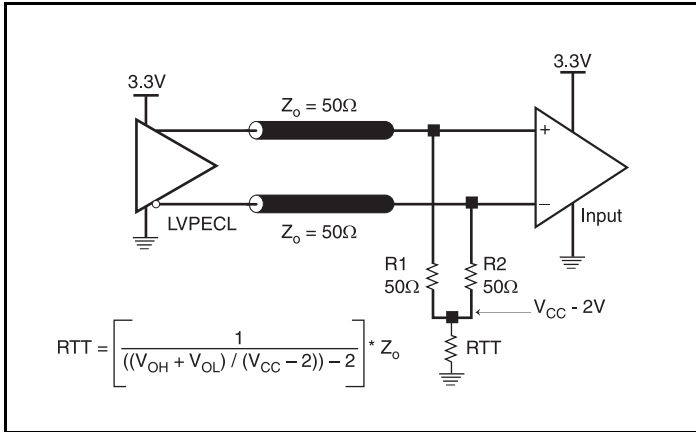

Figure 4A. 3.3V LVPECL Output Termination

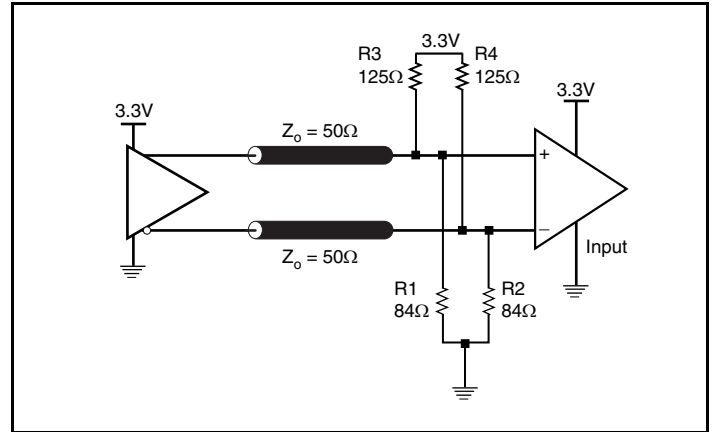

Figure 4B. 3.3V LVPECL Output Termination

Termination for 2.5V LVPECL Outputs

Figure 5A and Figure 5B show examples of termination for 2.5V LVPECL driver. These terminations are equivalent to terminating 50Ω to $V_{CC} - 2V$. For $V_{CC0} = 2.5V$, the $V_{CC0} - 2V$ is very close to ground

level. The R3 in Figure 5B can be eliminated and the termination is shown in Figure 5C.

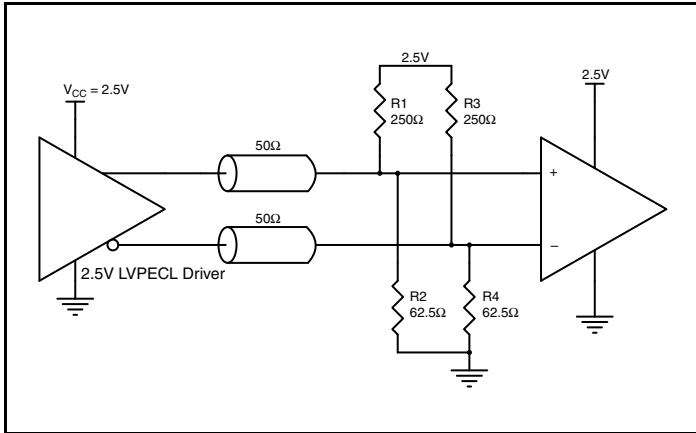

Figure 5A. 2.5V LVPECL Driver Termination Example

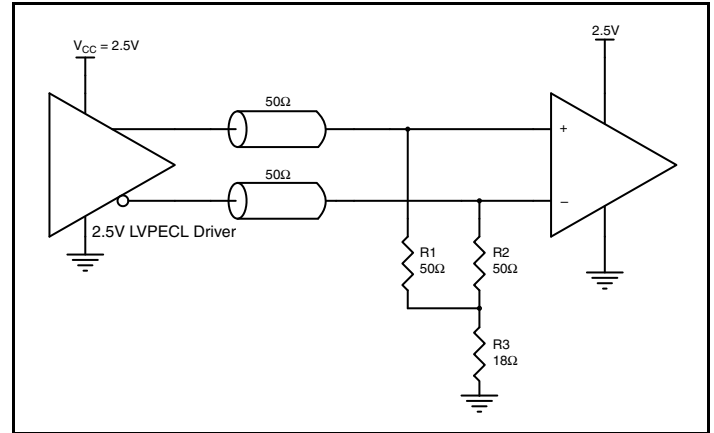

Figure 5B. 2.5V LVPECL Driver Termination Example

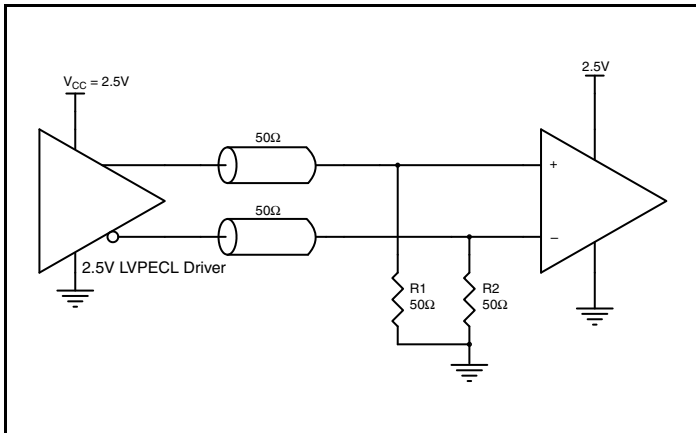

Figure 5C. 2.5V LVPECL Driver Termination Example

Application Schematic Example

Figure 6 shows an example of 85352 application schematic. In this example, the device is operated at $V_{CC} = 3.3V$. The decoupling capacitor should be located as close as possible to the power pin. For

the LVPECL output drivers, only two terminations examples are shown in this schematic. Additional termination approaches can be found in the LVPECL Termination Application Note.

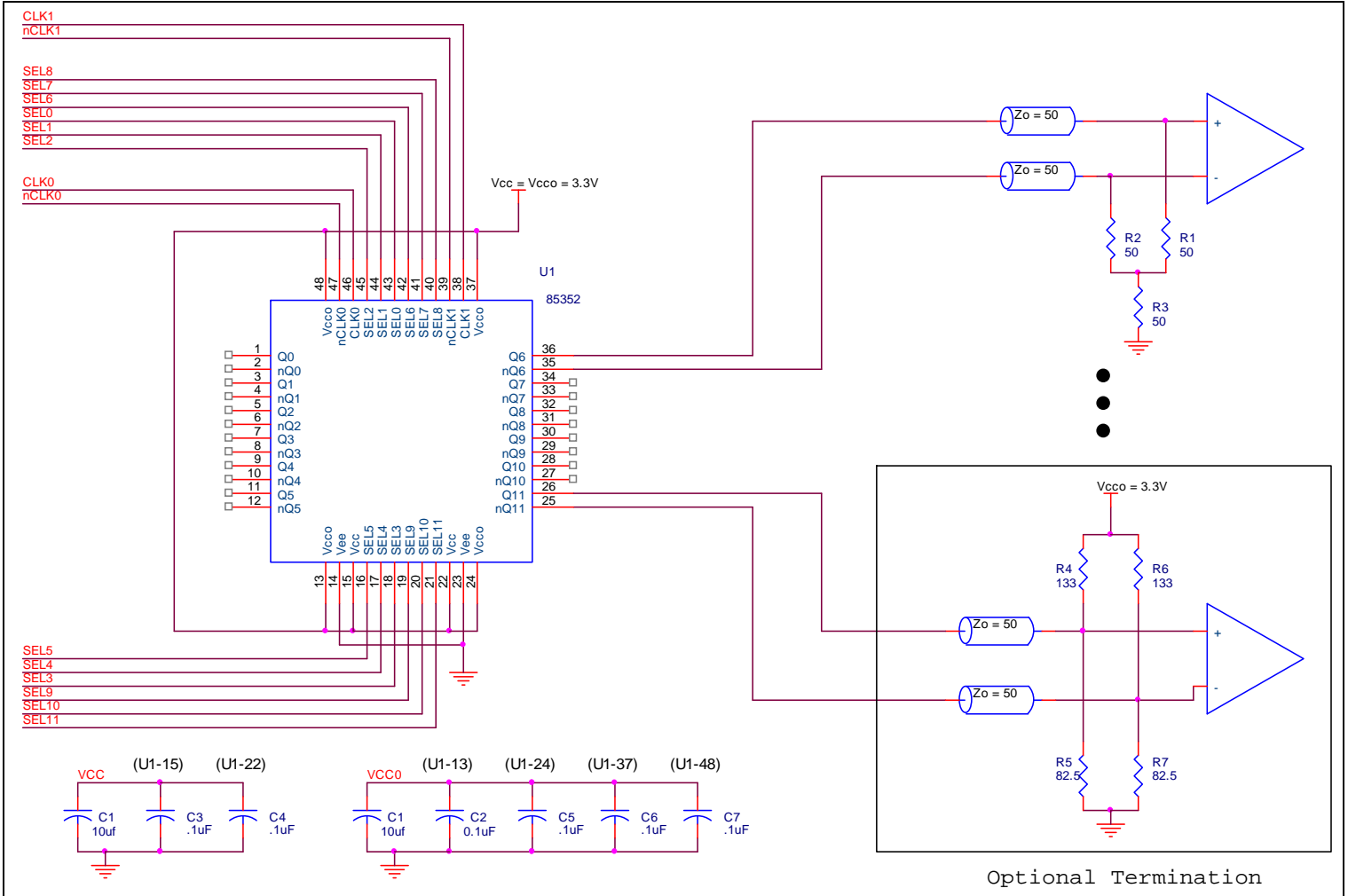

Figure 6. 85352 Application Schematic

Power Considerations

This section provides information on power dissipation and junction temperature for the 85352. Equations and example calculations are also provided.

1. Power Dissipation.

The total power dissipation for the 85352 is the sum of the core power plus the power dissipated in the load(s). The following is the power dissipation for $V_{CC} = 3.3V + 5\% = 3.465V$, which gives worst case results.

NOTE: Please refer to Section 3 for details on calculating power dissipated in the load.

- Power (core)_{MAX} = $V_{CC_MAX} * I_{EE_MAX} = 3.465V * 170mA = \mathbf{589.05mW}$
- Power (outputs)_{MAX} = **30mW/Loaded Output pair**
If all outputs are loaded, the total power is $12 * 30mW = \mathbf{360mW}$

Total Power_{MAX} (3.3V, with all outputs switching) = $589.05mW + 360mW = \mathbf{949.05mW}$

2. Junction Temperature.

Junction temperature, T_j , is the temperature at the junction of the bond wire and bond pad and it directly affects the reliability of the device. The maximum recommended junction temperature is 125°C. Limiting the internal transistor junction temperature, T_j , to 125°C ensures that the bond wire and bond pad temperature remains below 125°C.

The equation for T_j is as follows: $T_j = \theta_{JA} * Pd_total + T_A$

T_j = Junction Temperature

θ_{JA} = Junction-to-Ambient Thermal Resistance

Pd_total = Total Device Power Dissipation (example calculation is in section 1 above)

T_A = Ambient Temperature

In order to calculate junction temperature, the appropriate junction-to-ambient thermal resistance θ_{JA} must be used. Assuming a moderate air flow of 200 linear feet per minute and a multi-layer board, the appropriate value is 22.6°C/W per Table 6 below.

Therefore, T_j for an ambient temperature of 85°C with all outputs switching is:

$$85^\circ\text{C} + 0.949\text{W} * 22.6^\circ\text{C/W} = 106.4^\circ\text{C}. \text{ This is below the limit of } 125^\circ\text{C}.$$

This calculation is only an example. T_j will obviously vary depending on the number of loaded outputs, supply voltage, air flow and the type of board (multi-layer).

Table 6. Thermal Resistance θ_{JA} for 48 Lead TQFP, Forced Convection

θ_{JA} by Velocity			
Linear Feet per Minute	0	200	500
Multi-Layer PCB, JEDEC Standard Test Boards	27.6°C/W	22.6°C/W	20.78°C/W

3. Calculations and Equations.

The purpose of this section is to calculate the power dissipation for the LVPECL output pairs.

LVPECL output driver circuit and termination are shown in *Figure 5*.

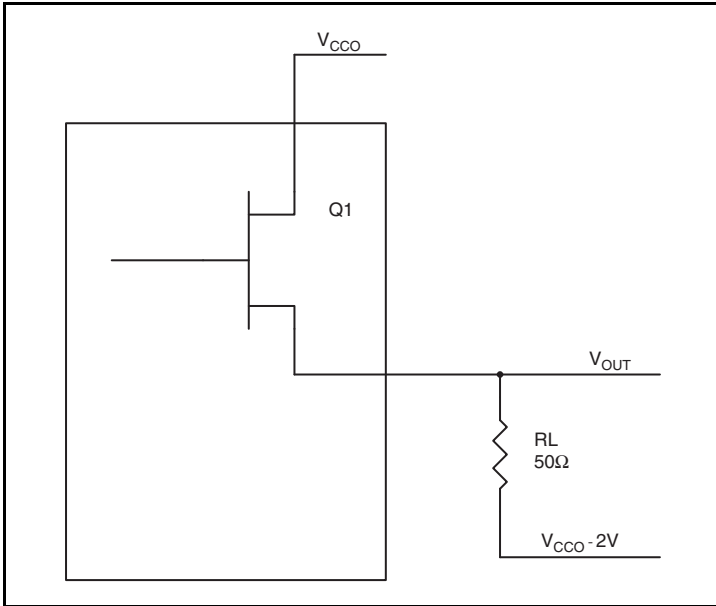

Figure 5. LVPECL Driver Circuit and Termination

To calculate worst case power dissipation into the load, use the following equations which assume a 50Ω load, and a termination voltage of $V_{CCO} - 2V$.

- For logic high, $V_{OUT} = V_{OH_MAX} = V_{CCO_MAX} - 0.9V$
 $(V_{CCO_MAX} - V_{OH_MAX}) = 0.9V$
- For logic low, $V_{OUT} = V_{OL_MAX} = V_{CCO_MAX} - 1.7V$
 $(V_{CCO_MAX} - V_{OL_MAX}) = 1.7V$

Pd_H is power dissipation when the output drives high.

Pd_L is the power dissipation when the output drives low.

$$Pd_H = [(V_{OH_MAX} - (V_{CCO_MAX} - 2V))/R_L] * (V_{CCO_MAX} - V_{OH_MAX}) = [(2V - (V_{CCO_MAX} - V_{OH_MAX}))/R_L] * (V_{CCO_MAX} - V_{OH_MAX}) = [(2V - 0.9V)/50\Omega] * 0.9V = \mathbf{19.8mW}$$

$$Pd_L = [(V_{OL_MAX} - (V_{CCO_MAX} - 2V))/R_L] * (V_{CCO_MAX} - V_{OL_MAX}) = [(2V - (V_{CCO_MAX} - V_{OL_MAX}))/R_L] * (V_{CCO_MAX} - V_{OL_MAX}) = [(2V - 1.7V)/50\Omega] * 1.7V = \mathbf{10.2mW}$$

Total Power Dissipation per output pair = $Pd_H + Pd_L = \mathbf{30mW}$

Reliability Information

Table 7. θ_{JA} vs. Air Flow Table for a 48 Lead TQFP, E-Pad

θ_{JA} vs. Air Flow			
Linear Feet per Minute	0	200	500
Multi-Layer PCB, JEDEC Standard Test Boards	27.6°C/W	22.6°C/W	20.78°C/W

Transistor Count

The transistor count for 85352 is: 2252

Package Outline and Package Dimensions

Package Outline - Y Suffix for 48 Lead TQFP, E-Pad

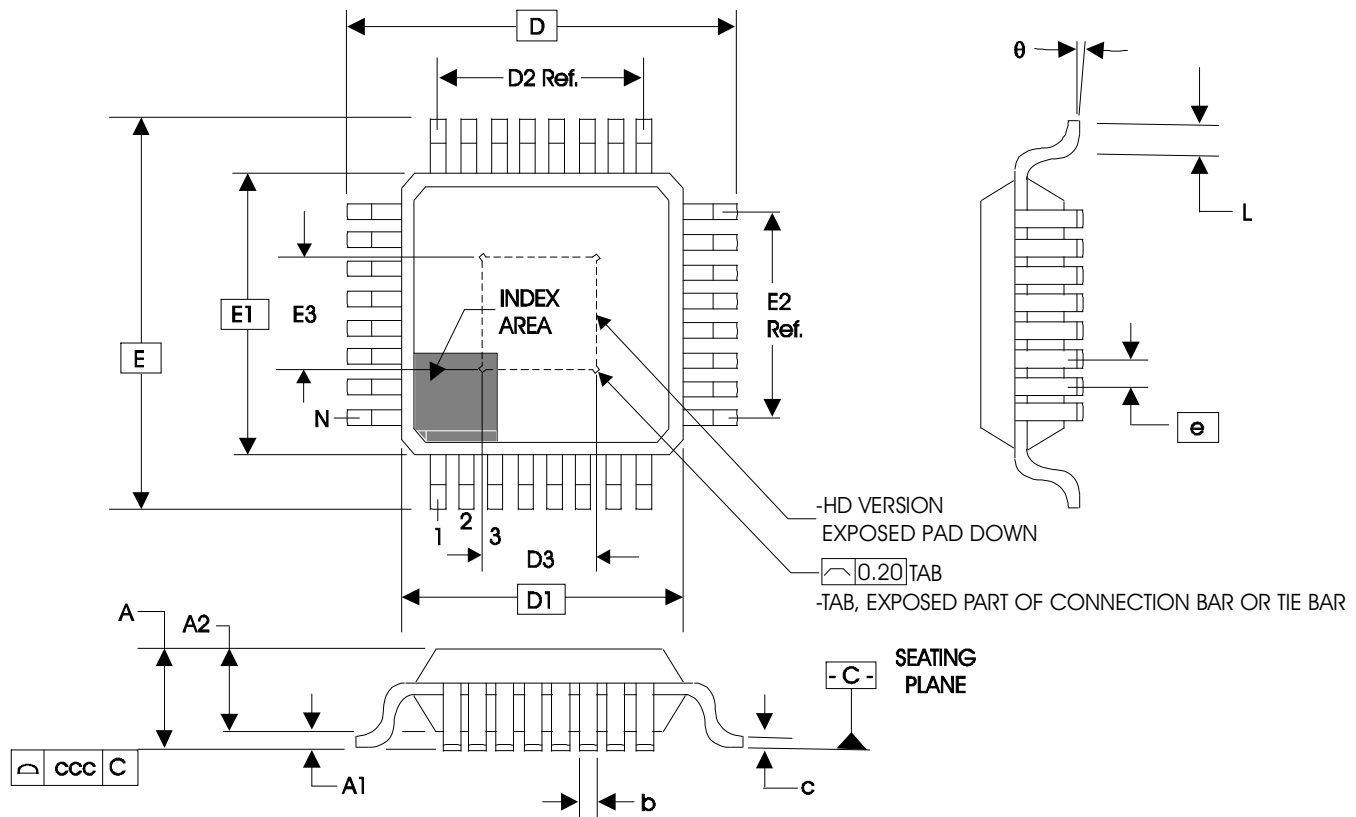

Table 8. Package Dimensions 48 Lead TQFP, E-Pad

JEDEC Variation: ABC - HD			
All Dimensions in Millimeters			
Symbol	Minimum	Nominal	Maximum
N	48		
A			1.20
A1	0.05	0.10	0.15
A2	0.95	1.00	1.05
b	0.17	0.22	0.27
c	0.09		0.20
D & E	9.00 Basic		
D1 & E1	7.00 Basic		
D2 & E2	5.50 Ref.		
D3 & E3		3.5	
e	0.50 Basic		
L	0.45	0.60	0.75
theta	0°		7°
ccc			0.08

Reference Document: JEDEC Publication 95, MS-026

Ordering Information

Table 9. Ordering Information Table

Part/Order Number	Marking	Package	Shipping Packaging	Temperature
85352AYILF	ICS85352AYIL	48 Lead TQFP, E-Pad, Lead-Free	Tray	-40°C to 85°C
85352AYILFT	ICS85352AYIL	48 Lead TQFP, E-Pad, Lead-Free	Tape & Reel	-40°C to 85°C

Revision History Sheet

Rev	Table	Page	Description of Change	Date
A	T9	1	Features Section - added lead-free bullet.	7/6/06
		6	Added Recommendations for Unused Input and Output Pins.	
		7	Added Thermal Release Path.	
		15	Ordering Information Table - added lead-free part number, marking and note.	
B	T4A	3	Power Supply DC Characteristics Table - corrected V_{CC} min. from 3.475V to 3.135V.	9/27/06
B	T4C T5A - T5B	3	Differential DC Characteristics Table - updates notes.	2/12/10
		4	AC Characteristics Tables - added thermal note.	
		7	Updated Wiring the Differential Input to Accept Single-ended Levels.	
	8	Updated EPAD Thermal Release Path.		
	9	Differential Clock input Interface - added Figure 3F.		
	12	Termination for 3.3V LVPECL Outputs - updated Figures 4A & 4B.		
T8 T9	15	Power Considerations - re-calculated ambient temperature using 0 air flow.		
	16	Updated Package Dimensions Table. Ordering Information Table - deleted "ICS" prefix from Part/Order Number		
B		16	Updated Package Outline.	3/9/10
B			Corrected title of datasheet from clock generator to clock buffer.	7/6/10
C	T5A - T5B	1	Features, corrected Propagation Delay bullet from 1.8ns to 2ns maximum.	8/3/10
		4	AC Characteristics Tables - added Additive Phase Jitter spec.	
	5	Added Additive Phase Jitter Plot.		
T8	17	Package Dimensions, corrected D3/E3 dimensions.		
D	T9	1	Features section - updated package bullet.	12/1/15
		18	Ordering Information Table - deleted leaded part rows and note. Deleted "ICS" prefix & "I" suffix from part number. Updated header/footer to new format.	

IMPORTANT NOTICE AND DISCLAIMER

RENESAS ELECTRONICS CORPORATION AND ITS SUBSIDIARIES (“RENESAS”) PROVIDES TECHNICAL SPECIFICATIONS AND RELIABILITY DATA (INCLUDING DATASHEETS), DESIGN RESOURCES (INCLUDING REFERENCE DESIGNS), APPLICATION OR OTHER DESIGN ADVICE, WEB TOOLS, SAFETY INFORMATION, AND OTHER RESOURCES “AS IS” AND WITH ALL FAULTS, AND DISCLAIMS ALL WARRANTIES, EXPRESS OR IMPLIED, INCLUDING, WITHOUT LIMITATION, ANY IMPLIED WARRANTIES OF MERCHANTABILITY, FITNESS FOR A PARTICULAR PURPOSE, OR NON-INFRINGEMENT OF THIRD-PARTY INTELLECTUAL PROPERTY RIGHTS.

These resources are intended for developers who are designing with Renesas products. You are solely responsible for (1) selecting the appropriate products for your application, (2) designing, validating, and testing your application, and (3) ensuring your application meets applicable standards, and any other safety, security, or other requirements. These resources are subject to change without notice. Renesas grants you permission to use these resources only to develop an application that uses Renesas products. Other reproduction or use of these resources is strictly prohibited. No license is granted to any other Renesas intellectual property or to any third-party intellectual property. Renesas disclaims responsibility for, and you will fully indemnify Renesas and its representatives against, any claims, damages, costs, losses, or liabilities arising from your use of these resources. Renesas' products are provided only subject to Renesas' Terms and Conditions of Sale or other applicable terms agreed to in writing. No use of any Renesas resources expands or otherwise alters any applicable warranties or warranty disclaimers for these products.

(Disclaimer Rev.1.01 Jan 2024)

Corporate Headquarters

TOYOSU FORESIA, 3-2-24 Toyosu,
Koto-ku, Tokyo 135-0061, Japan
www.renesas.com

Trademarks

Renesas and the Renesas logo are trademarks of Renesas Electronics Corporation. All trademarks and registered trademarks are the property of their respective owners.

Contact Information

For further information on a product, technology, the most up-to-date version of a document, or your nearest sales office, please visit www.renesas.com/contact-us/.

Looking for pricing, stock, or lifecycle information?

Click below to explore more details on WIN SOURCE:

-  [View 85352AYILF on WIN SOURCE](#)
-  [Renesas Electronics America](#) Information

Optimize Your Supply Chain with WIN SOURCE Solutions

-  Global Sourcing Solution
-  Obsolete Management
-  Cost Control Management
-  Shortage Management
-  Alternative Solution
-  Excess Inventory Management