



**THE DATASHEET OF**  
**8530FY-01LF**



### General Description

The ICS8530-01 is a low skew, 1-to-16 Differential-to-3.3V LVPECL Fanout Buffer. The CLK, nCLK pair can accept most standard differential input levels. The high gain differential amplifier accepts peak-to-peak input voltages as small as 150mV as long as the common mode voltage is within the specified minimum and maximum range.

Guaranteed output and part-to-part skew characteristics make the ICS8530-01 ideal for those clock distribution applications demanding well defined performance and repeatability.

### Features

- Sixteen differential 3.3V LVPECL outputs
- CLK, nCLK input pair
- CLK, nCLK pair can accept the following differential input levels: LVPECL, LVDS, LVHSTL, HCSL, SSTL
- Maximum output frequency: 500MHz
- Translates any single-ended input signal to 3.3V LVPECL levels with a resistor bias on nCLK input
- Output skew: 75ps (maximum)
- Part-to-part skew: 305ps (maximum)
- Additive phase jitter, RMS: 0.03ps (typical)
- Full 3.3V supply voltage
- 0°C to 70°C ambient operating temperature
- Available in both standard (RoHS 5) and lead-free (RoHS 6) packages

### Block Diagram

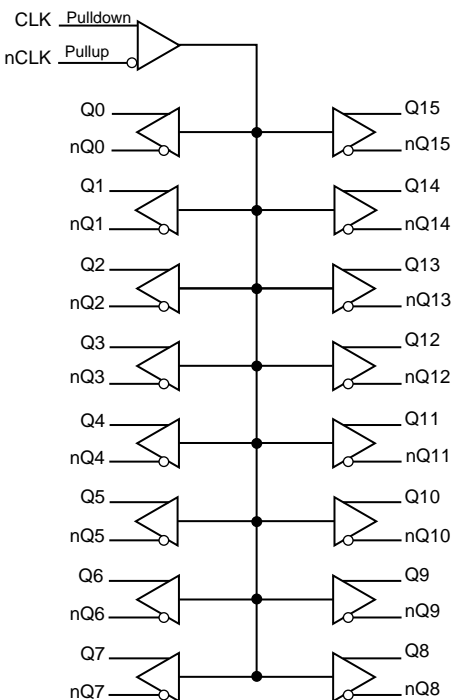

### Pin Assignment

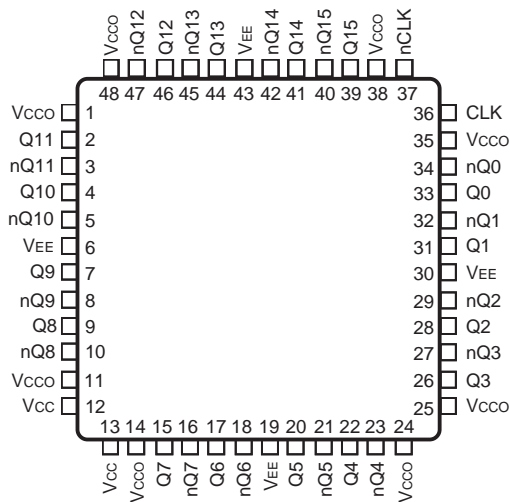

**ICS8530-01**  
**48-Lead LQFP**  
**7mm x 7mm x 1.4mm package body**  
**Y Package**  
**Top View**

**Table 1. Pin Descriptions**

Number	Name	Type		Description
1, 11, 14, 24, 25, 35, 38, 48	V <sub>CCO</sub>	Power		Output supply pins.
2, 3	Q11, nQ11	Output		Differential output pair. LVPECL interface levels.
4, 5	Q10, nQ10	Output		Differential output pair. LVPECL interface levels.
6, 19, 30, 43	V <sub>EE</sub>	Power		Negative supply pins.
7, 8	Q9, nQ9	Output		Differential output pair. LVPECL interface levels.
9, 10	Q8, nQ8	Output		Differential output pair. LVPECL interface levels.
12, 13	V <sub>CC</sub>	Power		Power supply pins.
15, 16	Q7, nQ7	Output		Differential output pair. LVPECL interface levels.
17, 18	Q6, nQ6	Output		Differential output pair. LVPECL interface levels.
20, 21	Q5, nQ5	Output		Differential output pair. LVPECL interface levels.
22, 23	Q4, nQ4	Output		Differential output pair. LVPECL interface levels.
26, 27	Q3, nQ3	Output		Differential output pair. LVPECL interface levels.
28, 29	Q2, nQ2	Output		Differential output pair. LVPECL interface levels.
31, 32	Q1, nQ1	Output		Differential output pair. LVPECL interface levels.
33, 34	Q0, nQ0	Output		Differential output pair. LVPECL interface levels.
36	CLK	Input	Pulldown	Non-inverting differential clock input.
37	nCLK	Input	Pullup	Inverting differential clock input.
39, 40	Q15, nQ15	Output		Differential output pair. LVPECL interface levels.
41, 42	Q14, nQ14	Output		Differential output pair. LVPECL interface levels.
44, 45	Q13, nQ13	Output		Differential output pair. LVPECL interface levels.
46, 47	Q12, nQ12	Output		Differential output pair. LVPECL interface levels.

NOTE: *Pullup* and *Pulldown* refer to internal input resistors. See Table 2, *Pin Characteristics*, for typical values.

**Table 2. Pin Characteristics**

Symbol	Parameter	Test Conditions	Minimum	Typical	Maximum	Units
C <sub>IN</sub>	Input Capacitance			3		pF
R <sub>PULLUP</sub>	Input Pullup Resistor			51		kΩ
R <sub>PULLDOWN</sub>	Input Pulldown Resistor			51		kΩ

## Function Table

Table 3. Clock Input Function Table

Inputs		Outputs		Input to Output Mode	Polarity
CLK	nCLK	Q[0:15]	nQ[0:15]		
0	1	LOW	HIGH	Differential to Differential	Non-Inverting
1	0	HIGH	LOW	Differential to Differential	Non-Inverting
0	Biased; NOTE 1	LOW	HIGH	Single-Ended to Differential	Non-Inverting
1	Biased; NOTE 1	HIGH	LOW	Single-Ended to Differential	Non-Inverting
Biased; NOTE 1	0	HIGH	LOW	Single-Ended to Differential	Inverting
Biased; NOTE 1	1	LOW	HIGH	Single-Ended to Differential	Inverting

NOTE 1: Refer to the Application Information section, *Wiring the Differential Input to Accept single-ended Levels*.

## Absolute Maximum Ratings

NOTE: Stresses beyond those listed under *Absolute Maximum Ratings* may cause permanent damage to the device. These ratings are stress specifications only. Functional operation of product at these conditions or any conditions beyond those listed in the *DC Characteristics* or *AC Characteristics* is not implied. Exposure to absolute maximum rating conditions for extended periods may affect product reliability.

Item	Rating
Supply Voltage, $V_{CC}$	4.6V
Inputs, $V_I$	-0.5V to $V_{CC} + 0.5V$
Outputs, $I_O$ Continuous Current Surge Current	50mA 100mA
Package Thermal Impedance, $\theta_{JA}$	53.9°C/W (0 mps)
Storage Temperature, $T_{STG}$	-65°C to 150°C

## DC Electrical Characteristics

Table 4A. Power Supply DC Characteristics,  $V_{CC} = V_{CCO} = 3.3V \pm 5\%$ ,  $V_{EE} = 0V$ ,  $T_A = 0^\circ C$  to  $70^\circ C$

Symbol	Parameter	Test Conditions	Minimum	Typical	Maximum	Units
$V_{CC}$	Power Supply Voltage		3.135	3.3	3.465	V
$V_{CCO}$	Output Supply Voltage		3.135	3.3	3.465	V
$I_{EE}$	Power Supply Current				146	mA

**Table 4B. Differential Input DC Characteristics,  $V_{CC} = V_{CCO} = 3.3V \pm 5\%$ ,  $V_{EE} = 0V$ ,  $T_A = 0^\circ C$  to  $70^\circ C$** 

Symbol	Parameter	Test Conditions	Minimum	Typical	Maximum	Units
$I_{IH}$	Input High Current	CLK	$V_{IN} = V_{CC} = 3.465V$		150	$\mu A$
		nCLK	$V_{IN} = V_{CC} = 3.465V$		5	$\mu A$
$I_{IL}$	Input Low Current	CLK	$V_{IN} = 0V$ , $V_{CC} = 3.465V$	-5		$\mu A$
		nCLK	$V_{IN} = 0V$ , $V_{CC} = 3.465V$	-150		$\mu A$
$V_{PP}$	Peak-to-Peak Input Voltage; NOTE 1		0.15		1.3	V
$V_{CMR}$	Common Mode Input Voltage; NOTE 1, 2		$V_{EE} + 0.5$		$V_{CC} - 0.85$	V

NOTE 1:  $V_{IL}$  should not be less than -0.3V.

NOTE 2: Common mode input voltage is defined as  $V_{IH}$ .

**Table 4C. LVPECL DC Characteristics,  $V_{CC} = V_{CCO} = 3.3V \pm 5\%$ ,  $V_{EE} = 0V$ ,  $T_A = 0^\circ C$  to  $70^\circ C$** 

Symbol	Parameter	Test Conditions	Minimum	Typical	Maximum	Units
$V_{OH}$	Output High Voltage; NOTE 1		$V_{CCO} - 1.4$		$V_{CCO} - 0.9$	V
$V_{OL}$	Output Low Voltage; NOTE 1		$V_{CCO} - 2.0$		$V_{CCO} - 1.7$	V
$V_{SWING}$	Peak-to-Peak Output Voltage Swing		0.6		1.0	V

NOTE 1: Outputs terminated with  $50\Omega$  to  $V_{CCO} - 2V$ .

## AC Electrical Characteristics

**Table 5. AC Electrical Characteristics,  $V_{CC} = V_{CCO} = 3.3V \pm 5\%$ ,  $V_{EE} = 0V$ ,  $T_A = 0^\circ C$  to  $70^\circ C$** 

Symbol	Parameter	Test Conditions	Minimum	Typical	Maximum	Units
$f_{MAX}$	Output Frequency				500	MHz
$t_{JIT}$	Buffer Additive Phase Jitter, RMS; refer to Additive Phase Jitter Section	106.25MHz, Integration Range: 12kHz – 20MHz		0.03		ps
$t_{PD}$	Propagation Delay; NOTE 1	$f \leq 500MHz$	1		2	ns
$t_{sk(o)}$	Output Skew; NOTE 2, 3				75	ps
$t_{sk(pp)}$	Part-to-Part Skew; NOTE 2, 4			148	305	ps
$t_R / t_F$	Output Rise/ Fall Time	20% to 80% @ 50MHz	300		750	ps
odc	Output Duty Cycle		47	50	53	%

NOTE: Electrical parameters are guaranteed over the specified ambient operating temperature range, which is established when device is mounted in a test socket with maintained transverse airflow greater than 500 lpm. Device will meet specifications after thermal equilibrium has been reached under these conditions.

NOTE All parameters measured at 250MHz unless noted otherwise.

NOTE 1: Measured from the differential input crossing point to the differential output crossing point.

NOTE 2: This parameter is defined in accordance with JEDEC Standard 65.

NOTE 3: Defined as skew between outputs at the same supply voltage and with equal load conditions. Measured at the differential cross points.

NOTE 4: Defined as skew between outputs on different devices operating at the same supply voltage, same temperature, same frequency and with equal load conditions. Using the same type of inputs on each device, the outputs are measured at the differential cross points.

## Additive Phase Jitter

The spectral purity in a band at a specific offset from the fundamental compared to the power of the fundamental is called the **dBc Phase Noise**. This value is normally expressed using a Phase noise plot and is most often the specified plot in many applications. Phase noise is defined as the ratio of the noise power present in a 1Hz band at a specified offset from the fundamental frequency to the power value of the fundamental. This ratio is expressed in decibels (dBm) or a ratio

of the power in the 1Hz band to the power in the fundamental. When the required offset is specified, the phase noise is called a **dBc** value, which simply means dBm at a specified offset from the fundamental. By investigating jitter in the frequency domain, we get a better understanding of its effects on the desired application over the entire time record of the signal. It is mathematically possible to calculate an expected bit error rate given a phase noise plot.

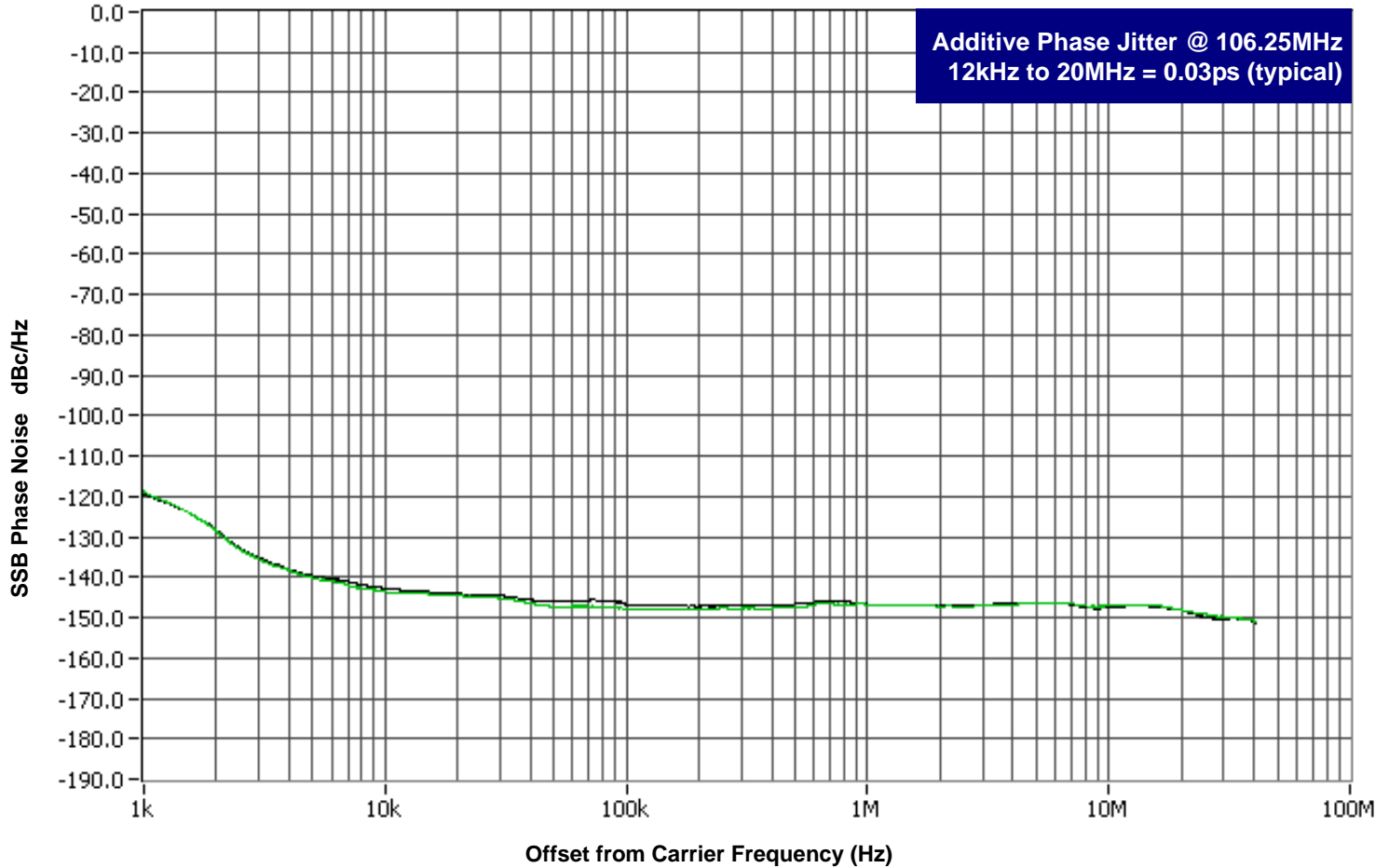

As with most timing specifications, phase noise measurements has issues relating to the limitations of the equipment. Often the noise floor of the equipment is higher than the noise floor of the device. This

is illustrated above. The device meets the noise floor of what is shown, but can actually be lower. The phase noise is dependent on the input source and measurement equipment.

## Parameter Measurement Information

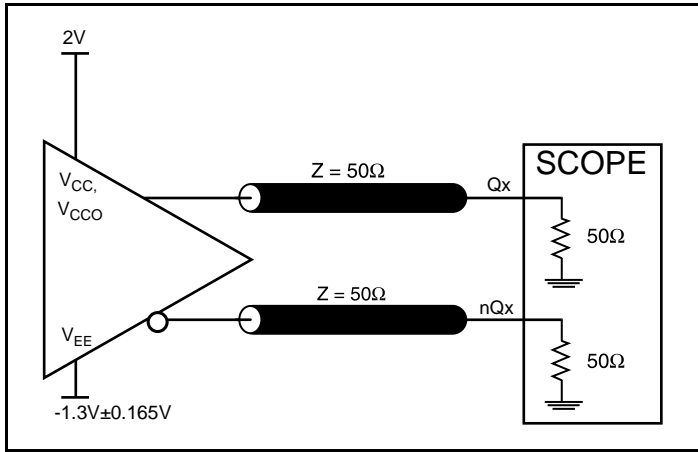

3.3V Output Load AC Test Circuit

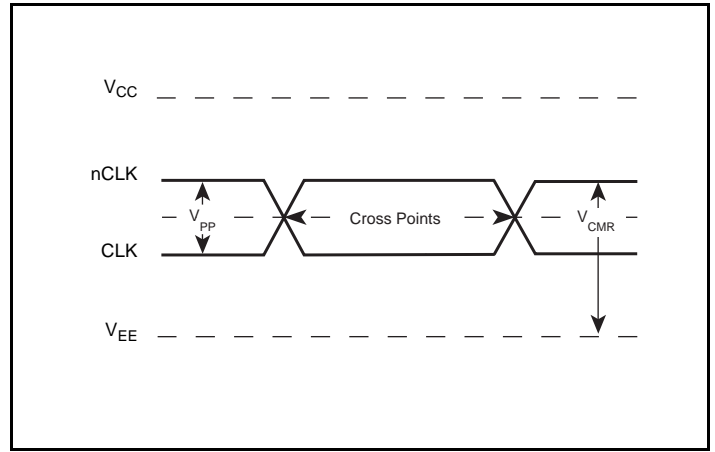

Differential Input Level

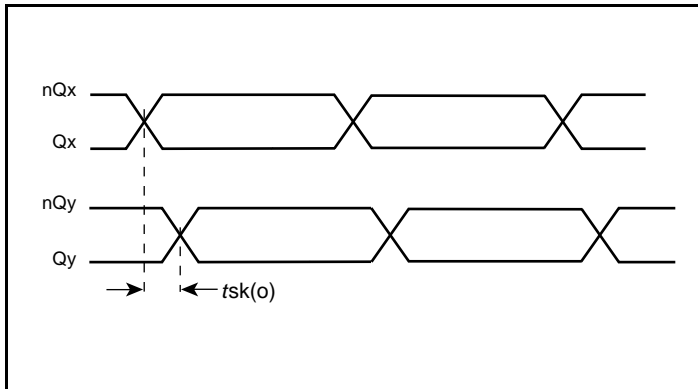

Output Skew

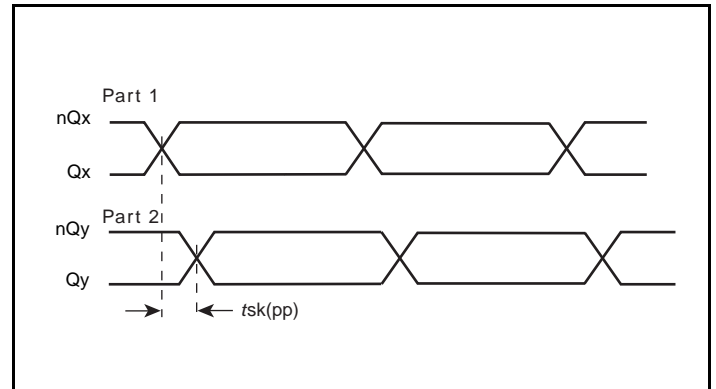

Part-to-Part Skew

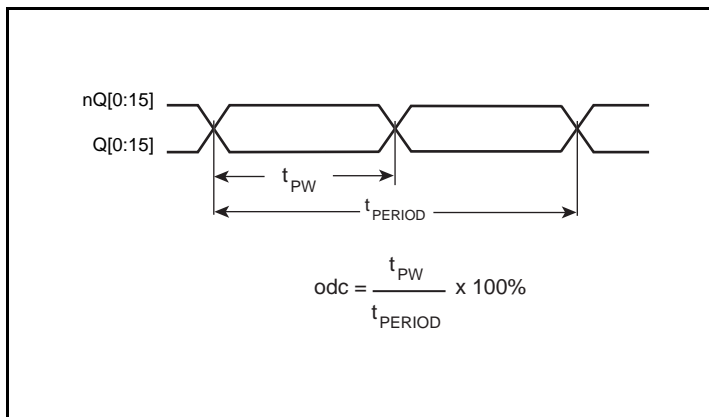

Output Duty Cycle/Pulse Width/Period

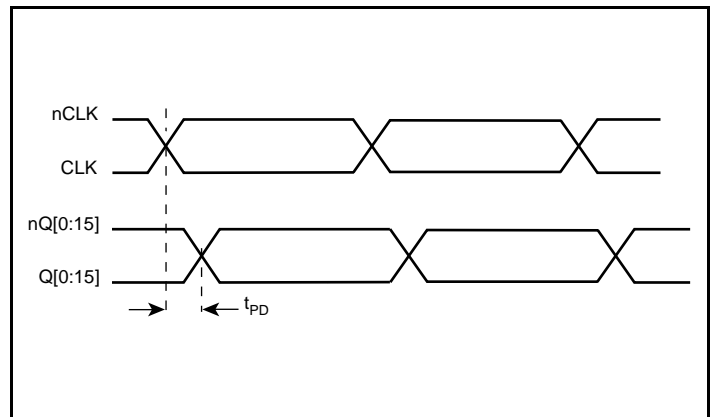

Propagation Delay

## Parameter Measurement Information, continued

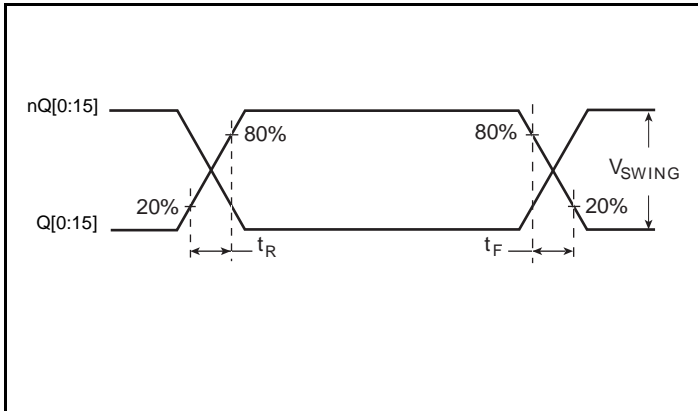

Output Rise/Fall Time

## Applications Information

### Recommendations for Unused Output Pins

#### Outputs:

##### LVPECL Outputs

The unused LVPECL output pair can be left floating. We recommend that there is no trace attached. Both sides of the differential output pair should either be left floating or terminated.

## Wiring the Differential Input to Accept Single-Ended Levels

Figure 1 shows how a differential input can be wired to accept single ended levels. The reference voltage  $V_{REF} = V_{CC}/2$  is generated by the bias resistors R1 and R2. The bypass capacitor (C1) is used to help filter noise on the DC bias. This bias circuit should be located as close to the input pin as possible. The ratio of R1 and R2 might need to be adjusted to position the  $V_{REF}$  in the center of the input voltage swing. For example, if the input clock swing is 2.5V and  $V_{CC} = 3.3V$ , R1 and R2 value should be adjusted to set  $V_{REF}$  at 1.25V. The values below are for when both the single ended swing and  $V_{CC}$  are at the same voltage. This configuration requires that the sum of the output impedance of the driver ( $R_o$ ) and the series resistance ( $R_s$ ) equals the transmission line impedance. In addition, matched termination at the input will attenuate the signal in half. This can be done in one of two ways. First, R3 and R4 in parallel should equal the transmission

line impedance. For most 50Ω applications, R3 and R4 can be 100Ω. The values of the resistors can be increased to reduce the loading for slower and weaker LVCMOS driver. When using single-ended signaling, the noise rejection benefits of differential signaling are reduced. Even though the differential input can handle full rail LVCMOS signaling, it is recommended that the amplitude be reduced. The datasheet specifies a lower differential amplitude, however this only applies to differential signals. For single-ended applications, the swing can be larger, however  $V_{IL}$  cannot be less than  $-0.3V$  and  $V_{IH}$  cannot be more than  $V_{CC} + 0.3V$ . Though some of the recommended components might not be used, the pads should be placed in the layout. They can be utilized for debugging purposes. The datasheet specifications are characterized and guaranteed by using a differential signal.

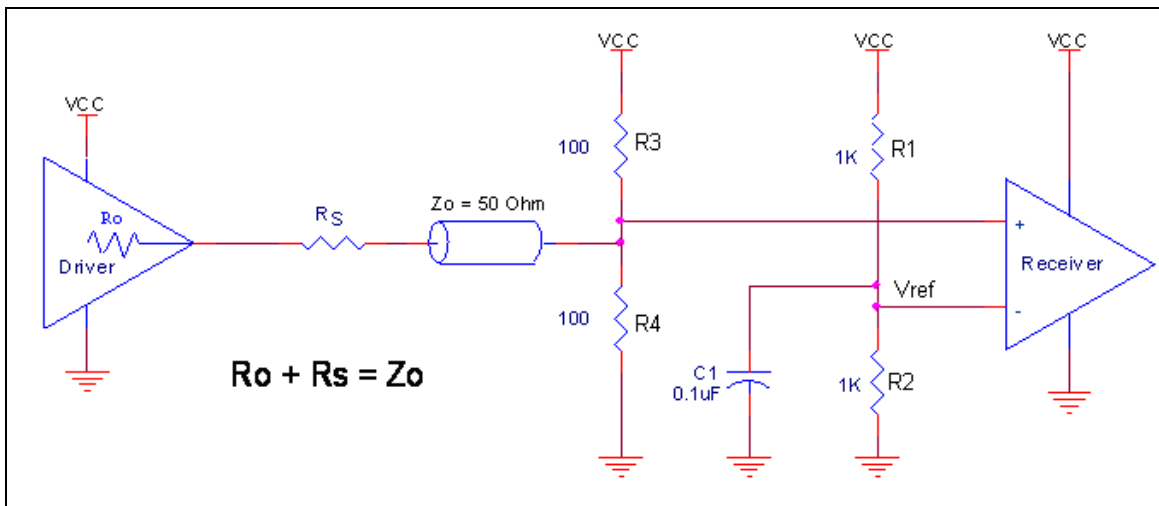
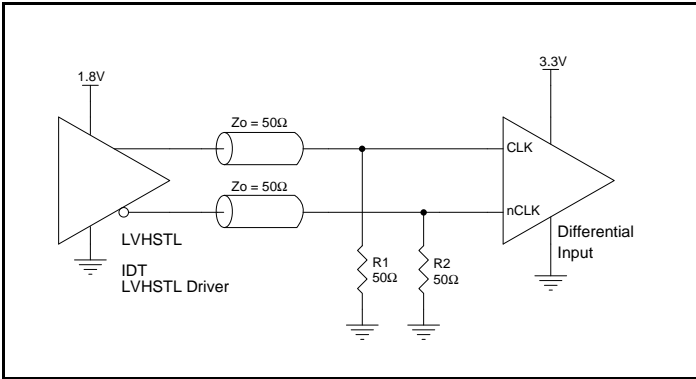

Figure 1. Recommended Schematic for Wiring a Differential Input to Accept Single-ended Levels

## Differential Clock Input Interface

The CLK/nCLK accepts LVDS, LVPECL, LVHSTL, SSTL, HCSL and other differential signals. Both  $V_{SWING}$  and  $V_{OH}$  must meet the  $V_{PP}$  and  $V_{CMR}$  input requirements. Figures 2A to 2F show interface examples for the CLK/nCLK input driven by the most common driver types. The input interfaces suggested here are examples only. Please consult

with the vendor of the driver component to confirm the driver termination requirements. For example in *Figure 2A*, the input termination applies for IDT's LVHSTL drivers. If you are using an LVHSTL driver from another vendor, use their termination recommendation.



**Figure 2A. CLK/nCLK Input Driven by an IDT LVHSTL Driver**

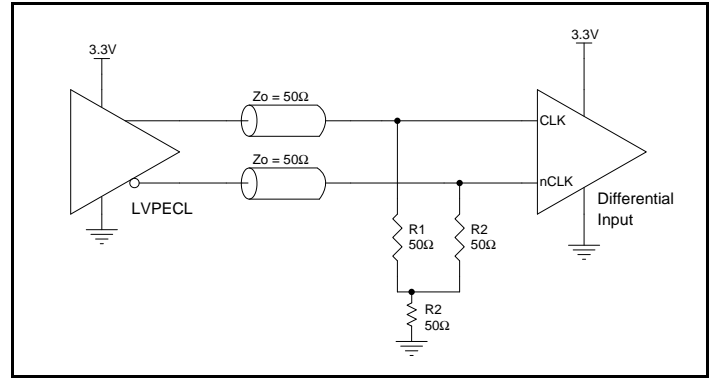

**Figure 2B. CLK/nCLK Input Driven by a 3.3V LVPECL Driver**

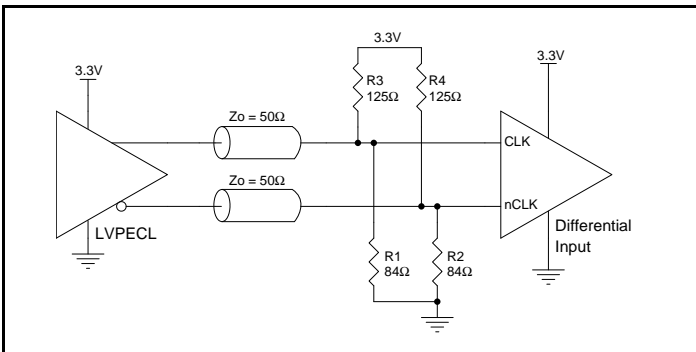

**Figure 2C. CLK/nCLK Input Driven by a 3.3V LVPECL Driver**

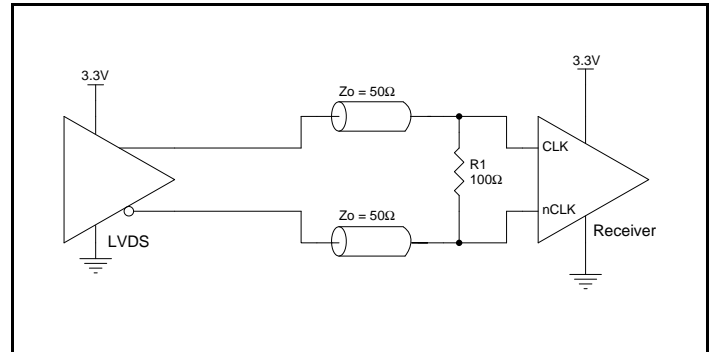

**Figure 2D. CLK/nCLK Input Driven by a 3.3V LVDS Driver**

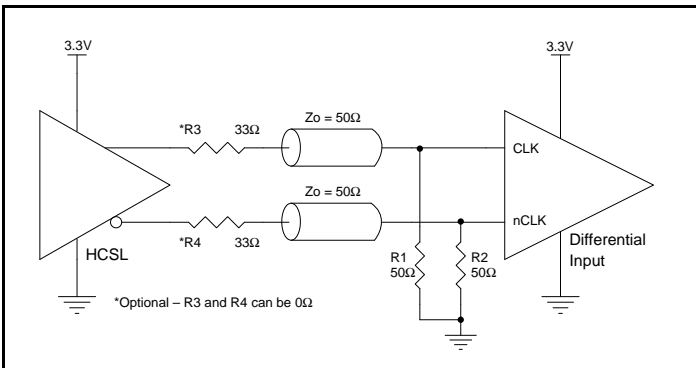

**Figure 2E. CLK/nCLK Input Driven by a 3.3V HCSL Driver**

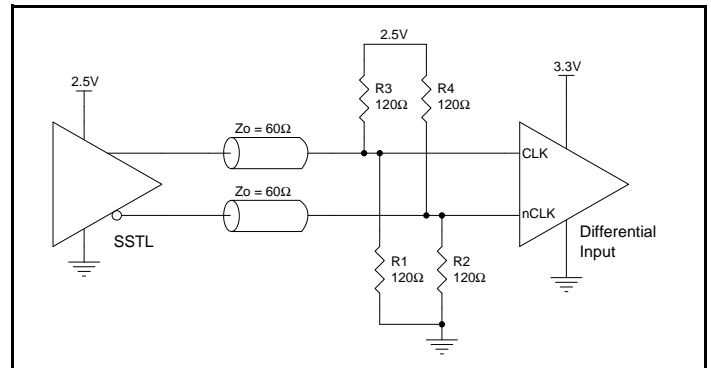

**Figure 2F. CLK/nCLK Input Driven by a 2.5V SSTL Driver**

## Termination for 3.3V LVPECL Outputs

The clock layout topology shown below is a typical termination for LVPECL outputs. The two different layouts mentioned are recommended only as guidelines.

The differential outputs are low impedance follower outputs that generate ECL/LVPECL compatible outputs. Therefore, terminating resistors (DC current path to ground) or current sources must be used for functionality. These outputs are designed to drive 50Ω

transmission lines. Matched impedance techniques should be used to maximize operating frequency and minimize signal distortion.

Figures 3A and 3B show two different layouts which are recommended only as guidelines. Other suitable clock layouts may exist and it would be recommended that the board designers simulate to guarantee compatibility across all printed circuit and clock component process variations.

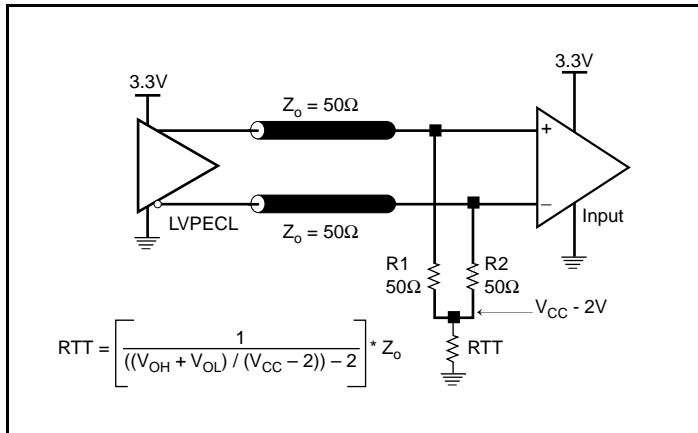

Figure 3A. 3.3V LVPECL Output Termination

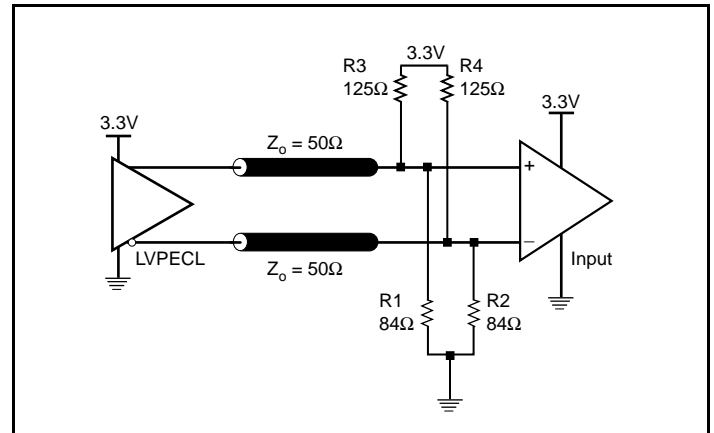

Figure 3B. 3.3V LVPECL Output Termination

## Power Considerations

This section provides information on power dissipation and junction temperature for the ICS8530-01. Equations and example calculations are also provided.

### 1. Power Dissipation.

The total power dissipation for the ICS8530-01 is the sum of the core power plus the power dissipated in the load(s). The following is the power dissipation for  $V_{CC} = 3.3V + 5\% = 3.465V$ , which gives worst case results.

NOTE: Please refer to Section 3 for details on calculating power dissipated in the load.

- Power (core)<sub>MAX</sub> =  $V_{CC\_MAX} * I_{EE\_MAX} = 3.465V * 146mA = 505.89mW$
- Power (outputs)<sub>MAX</sub> = **30mW/Loaded Output pair**  
If all outputs are loaded, the total power is  $16 * 30mW = 480mW$

**Total Power<sub>MAX</sub>** (3.465V, with all outputs switching) =  $505.89mW + 480mW = 985.89mW$

### 2. Junction Temperature.

Junction temperature,  $T_j$ , is the temperature at the junction of the bond wire and bond pad and it directly affects the reliability of the device. The maximum recommended junction temperature is 125°C. Limiting the internal transistor junction temperature,  $T_j$ , to 125°C ensures that the bond wire and bond pad temperature remains below 125°C.

The equation for  $T_j$  is as follows:  $T_j = \theta_{JA} * Pd\_total + T_A$

$T_j$  = Junction Temperature

$\theta_{JA}$  = Junction-to-Ambient Thermal Resistance

$Pd\_total$  = Total Device Power Dissipation (example calculation is in section 1 above)

$T_A$  = Ambient Temperature

In order to calculate junction temperature, the appropriate junction-to-ambient thermal resistance  $\theta_{JA}$  must be used. Assuming no air flow and a multi-layer board, the appropriate value is 53.9°C/W per Table 6 below.

Therefore,  $T_j$  for an ambient temperature of 70°C with all outputs switching is:

$$70^\circ C + 0.986W * 53.9^\circ C/W = 123.1^\circ C. \text{ This is below the limit of } 125^\circ C.$$

This calculation is only an example.  $T_j$  will obviously vary depending on the number of loaded outputs, supply voltage, air flow and the type of board (multi-layer).

**Table 6. Thermal Resistance  $\theta_{JA}$  for 48 Lead LQFP, Forced Convection**

$\theta_{JA}$ by Velocity			
Meters per Second	0	1	2.5
Multi-Layer PCB, JEDEC Standard Test Boards	53.9°C/W	47.7°C/W	45.0°C/W

### 3. Calculations and Equations.

The purpose of this section is to calculate the power dissipation for the LVPECL output pairs.

LVPECL output driver circuit and termination are shown in *Figure 4*.

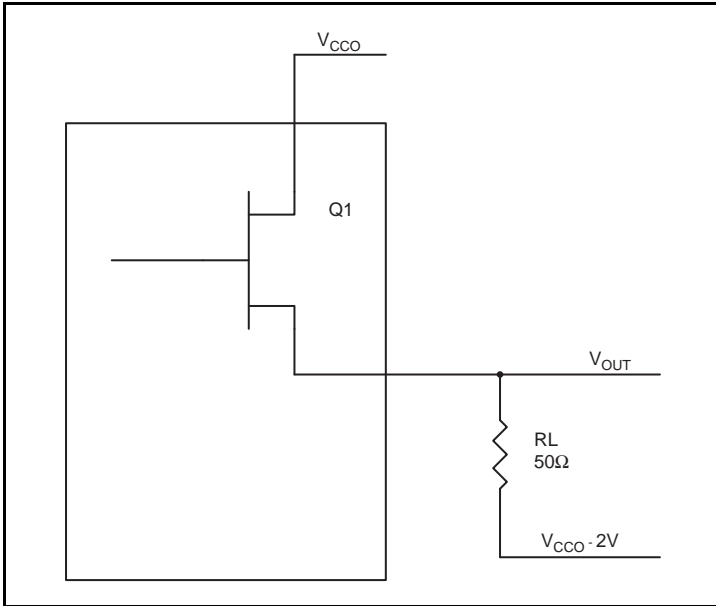

**Figure 4. LVPECL Driver Circuit and Termination**

To calculate worst case power dissipation into the load, use the following equations which assume a 50Ω load, and a termination voltage of V<sub>CCO</sub> - 2V.

- For logic high, V<sub>OUT</sub> = V<sub>OH\_MAX</sub> = V<sub>CCO\_MAX</sub> - 0.9V  
(V<sub>CCO\_MAX</sub> - V<sub>OH\_MAX</sub>) = 0.9V
- For logic low, V<sub>OUT</sub> = V<sub>OL\_MAX</sub> = V<sub>CCO\_MAX</sub> - 1.7V  
(V<sub>CCO\_MAX</sub> - V<sub>OL\_MAX</sub>) = 1.7V

Pd<sub>H</sub> is power dissipation when the output drives high.

Pd<sub>L</sub> is the power dissipation when the output drives low.

$$Pd_H = [(V_{OH\_MAX} - (V_{CCO\_MAX} - 2V))/R_L] * (V_{CCO\_MAX} - V_{OH\_MAX}) = [(2V - (V_{CCO\_MAX} - V_{OH\_MAX}))/R_L] * (V_{CCO\_MAX} - V_{OH\_MAX}) = [(2V - 0.9V)/50\Omega] * 0.9V = \mathbf{19.8mW}$$

$$Pd_L = [(V_{OL\_MAX} - (V_{CCO\_MAX} - 2V))/R_L] * (V_{CCO\_MAX} - V_{OL\_MAX}) = [(2V - (V_{CCO\_MAX} - V_{OL\_MAX}))/R_L] * (V_{CCO\_MAX} - V_{OL\_MAX}) = [(2V - 1.7V)/50\Omega] * 1.7V = \mathbf{10.2mW}$$

Total Power Dissipation per output pair = Pd<sub>H</sub> + Pd<sub>L</sub> = **30mW**

## Reliability Information

Table 7.  $\theta_{JA}$  vs. Air Flow Table for a 48 Lead LQFP

$\theta_{JA}$ vs. Air Flow			
Meters per Second	0	1	2.5
Multi-Layer PCB, JEDEC Standard Test Boards	53.9°C/W	47.7°C/W	45.0°C/W

## Transistor Count

The transistor count for ICS8530-01 is: 955

# Package Outline and Package Dimensions

## Package Outline - Y Suffix for 48 Lead LQFP

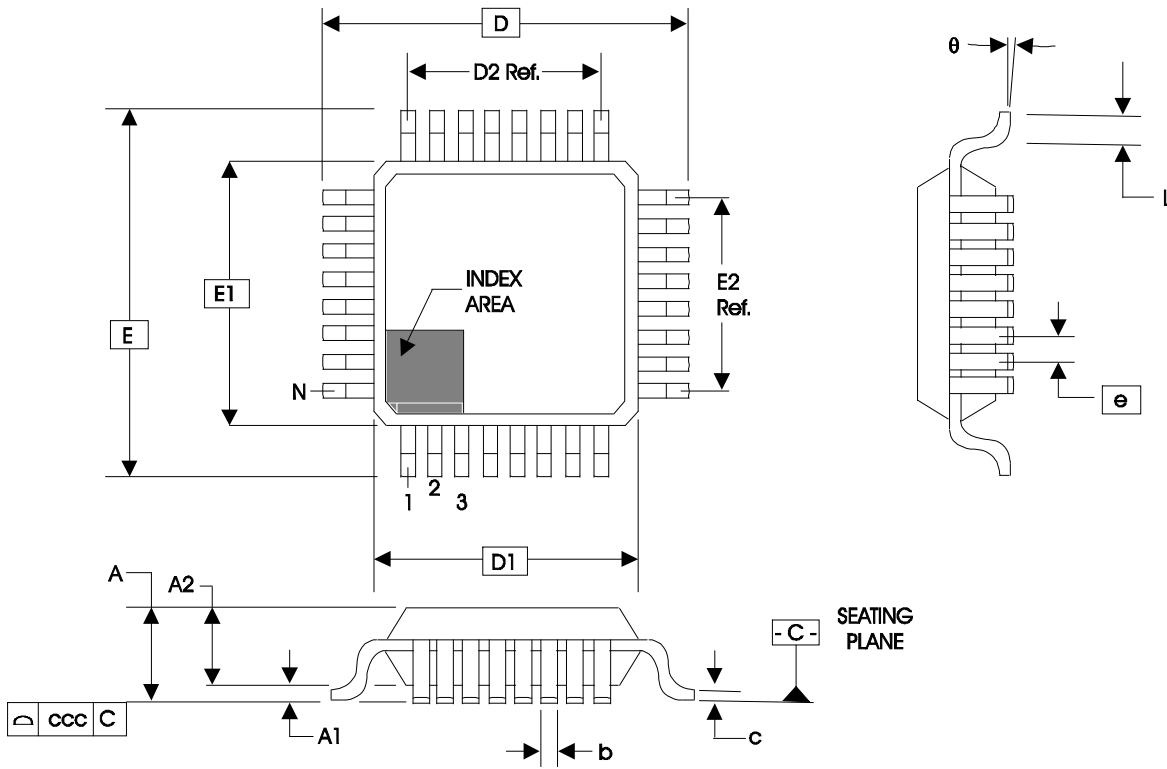

Table 8. Package Dimensions for 48 Lead LQFP

JEDEC Variation: BCB - HD			
All Dimensions in Millimeters			
Symbol	Minimum	Nominal	Maximum
N	48		
A			1.60
A1	0.05	0.10	0.15
A2	1.35	1.40	1.45
b	0.17	0.22	0.27
c	0.09		0.20
D & E	9.00 Basic		
D1 & E1	7.00 Basic		
D2 & E2	5.50 Ref.		
e	0.5 Basic		
L	0.45	0.60	0.75
$\theta$	0°		7°
ccc			0.08

Reference Document: JEDEC Publication 95, MS-026

**Table 9. Ordering Information**

<b>Part/Order Number</b>	<b>Marking</b>	<b>Package</b>	<b>Shipping Packaging</b>	<b>Temperature</b>
8530FY-01LF	ICS8530F01LF	Lead-Free, 48 Lead LQFP	Tray	0°C to 70°C
8530FY-01LFT	ICS8530F01LF	Lead-Free, 48 Lead LQFP	1000 Tape & Reel	0°C to 70°C

NOTE: "LF" suffix to the part number are the Pb-Free configuration and are RoHS compliant.

## Revision History Sheet

Rev	Table	Page	Description of Change	Date
B		5-6 7	Updated figures. Added Termination for LVPECL Outputs section.	05/28/02
B		2 5	Pin Description table - $V_{CC}$ description changed to "Core supply pin" from "Positive supply pin". Output Load Test Circuit diagram - corrected $V_{EE}$ equation to read, $V_{EE} = -1.3V \pm 0.165V$ from $V_{EE} = -1.3V \pm 0.135V$ .	10/02/02
C	T2 T4A	2 3 3 6 7 8	Pin Characteristics table - changed $C_{IN}$ 4pF max. to 4pF typical. Updated AMR Output rating. Power Supply table - changed $I_{EE}$ max. from 120mA to 140mA. Updated Single Ended Signal Driving Differential Input diagram. Added Differential Clock Input Interface section. Power Considerations, changed $I_{EE}$ to 140mA to reflect the Power Supply table and recalculated the equations. Update format throughout the data sheet.	4/7/04
C	T9	12	Added "Lead-Free" marking to Ordering Information Table.	6/29/04
D		1 4	Features section - added Additive Phase Jitter bullet. AC Characteristics table - added $t_{jit}$ row.	2/28/05
	T5	5	Added Additive Phase Jitter section.	
E	T4C T9	3 7 14	LVPECL DC Characteristics - changed $V_{SWING}$ (max) limit from 850mV to 1.0V. Corrected $V_{OH}$ (max) limit from $V_{CCO} - 1.0V$ to $V_{CCO} - 0.9V$ . Added Recommendations for Unused Output Pins. Ordering Information Table - added lead-free note.	5/19/06
F	1 2 T4A T4B T5 T9	2 2 3 3 4 4 8 9 10 11 13 15	Pin Description Table - change $V_{CC}$ description from "Core" to "Power". Pin Characteristics Table - change $C_{IN}$ from 4pF typical to 3pF typical. Absolute Maximum Rating - updated Thermal Impedance. Power Supply DC Characteristics Table - change $I_{EE}$ from 140mA max to 146mA max. Differential DC Characteristics Table - updated notes. AC Characteristics Table - changed part-to-part skew spec and Output Rise/Fall Time spec. Updated Wiring the Differential Input to Accept Single-ended Levels. Updated Differential Clock Input Interface. Updated Figures 3A and 3B. Updated Power Considerations to reflect power supply table, and updated Thermal Resistance Table. Updated Thermal Table and Transistor Count. Ordering Information Table - deleted "ICS" prefix in Part/Order column. Changed revision from "D" to "F". Converted datasheet format.	11/18/10
G	T5	4	AC Characteristics Table - corrected typical part-to-part skew spec from 150 to 148ps.	11/30/10
G	T9	15	Removed leaded orderable parts from Ordering Information table	11/15/12



## IMPORTANT NOTICE AND DISCLAIMER

RENESAS ELECTRONICS CORPORATION AND ITS SUBSIDIARIES (“RENESAS”) PROVIDES TECHNICAL SPECIFICATIONS AND RELIABILITY DATA (INCLUDING DATASHEETS), DESIGN RESOURCES (INCLUDING REFERENCE DESIGNS), APPLICATION OR OTHER DESIGN ADVICE, WEB TOOLS, SAFETY INFORMATION, AND OTHER RESOURCES “AS IS” AND WITH ALL FAULTS, AND DISCLAIMS ALL WARRANTIES, EXPRESS OR IMPLIED, INCLUDING, WITHOUT LIMITATION, ANY IMPLIED WARRANTIES OF MERCHANTABILITY, FITNESS FOR A PARTICULAR PURPOSE, OR NON-INFRINGEMENT OF THIRD-PARTY INTELLECTUAL PROPERTY RIGHTS.

These resources are intended for developers who are designing with Renesas products. You are solely responsible for (1) selecting the appropriate products for your application, (2) designing, validating, and testing your application, and (3) ensuring your application meets applicable standards, and any other safety, security, or other requirements. These resources are subject to change without notice. Renesas grants you permission to use these resources only to develop an application that uses Renesas products. Other reproduction or use of these resources is strictly prohibited. No license is granted to any other Renesas intellectual property or to any third-party intellectual property. Renesas disclaims responsibility for, and you will fully indemnify Renesas and its representatives against, any claims, damages, costs, losses, or liabilities arising from your use of these resources. Renesas' products are provided only subject to Renesas' Terms and Conditions of Sale or other applicable terms agreed to in writing. No use of any Renesas resources expands or otherwise alters any applicable warranties or warranty disclaimers for these products.

(Disclaimer Rev.1.01 Jan 2024)

### Corporate Headquarters

TOYOSU FORESIA, 3-2-24 Toyosu,  
Koto-ku, Tokyo 135-0061, Japan  
[www.renesas.com](http://www.renesas.com)

### Trademarks

Renesas and the Renesas logo are trademarks of Renesas Electronics Corporation. All trademarks and registered trademarks are the property of their respective owners.

### Contact Information

For further information on a product, technology, the most up-to-date version of a document, or your nearest sales office, please visit [www.renesas.com/contact-us/](http://www.renesas.com/contact-us/).

## Looking for pricing, stock, or lifecycle information?

Click below to explore more details on WIN SOURCE:

-  [View 8530FY-01LF on WIN SOURCE](#)
-  [Renesas Electronics America](#) Information

## Optimize Your Supply Chain with WIN SOURCE Solutions

-  Global Sourcing Solution
-  Obsolete Management
-  Cost Control Management
-  Shortage Management
-  Alternative Solution
-  Excess Inventory Management