



**THE DATASHEET OF**  
**5V41065PGG**



## Recommended Applications

2 Output synthesizer for PCIe Gen1/2 and Ethernet

## General Description

The IDT5V41065 is a PCIe Gen2 compliant spread spectrum capable clock generator. The device has 2 differential HCSL outputs and can be used in communication or embedded systems to substantially reduce electro-magnetic interference (EMI). The spread amount and output frequency are selectable via select pins. The IDT5V41065 can also supply 25 MHz, 125 MHz and 200 MHz outputs for applications such as Ethernet.

## Output Features

- 2 - 0.7V current mode differential HCSL output pairs

## Features/Benefits

- 16-pin TSSOP and QFN packages; small board footprint
- Spread-spectrum capable; reduces EMI
- Outputs can be terminated to LVDS; can drive a wider variety of devices
- 25 MHz, 125 MHz and 200 MHz output frequencies; TSSOP only
- 100MHz and 200MHz output frequencies; VFQFPN package
- OE control pin; greater system power management
- Spread% and frequency pin selection; no software required to configure device
- Industrial temperature range available; supports demanding embedded applications
- **For PCIe Gen3 applications, see the 5V41235**

## Key Specifications

- Cycle-to-cycle jitter < 100 ps
- Output-to-output skew < 50 ps
- PCIe Gen2 phase jitter < 3.0ps RMS

## Block Diagram

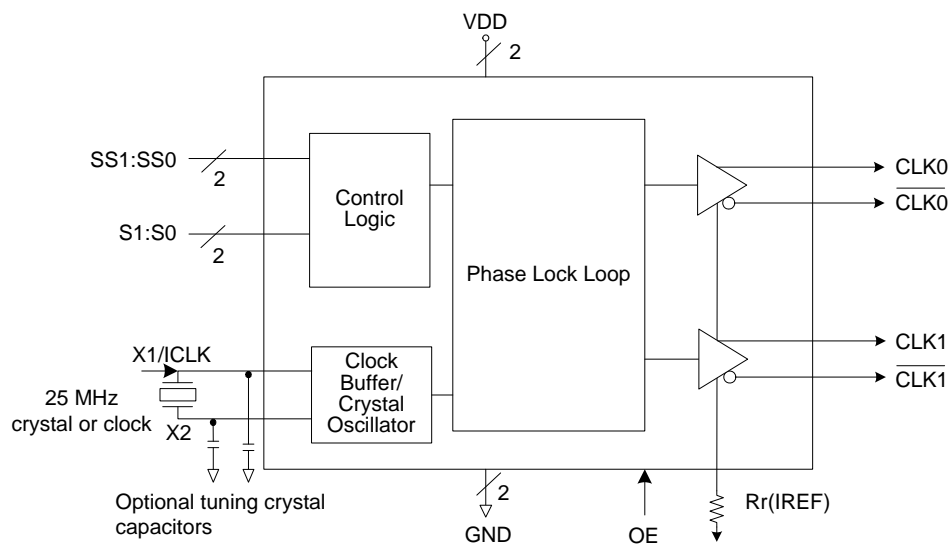

## Pin Assignment

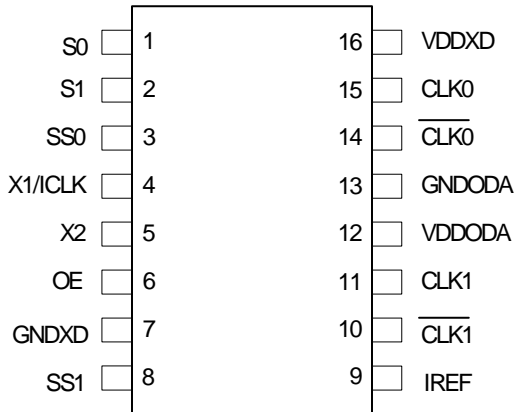

16-pin (173 mil) TSSOP

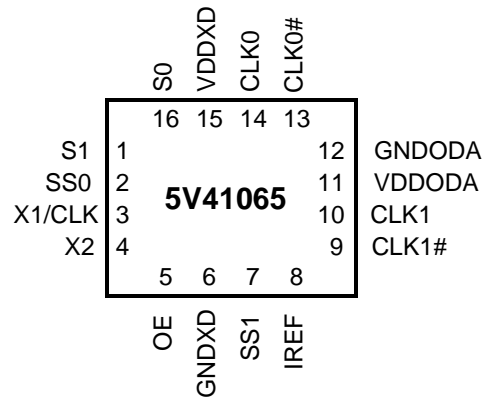

16-pin VFQFPN

Output Select Table 1 (MHz)–TSSOP only

S1	S0	CLK(1:0), CLK(1:0)
0	0	25M
0	1	100M
1	0	125M
1	1	200M

Spread Selection Table 2–TSSOP only

SS1	SS0	Spread%
0	0	No Spread
0	1	Down -0.5
1	0	Down -0.75
1	1	No Spread

Output/Spread Select Table 3 - VFQFPN Only

S1	S0	SS1	SS0	Output	Spread%
0	0	0	0	100MHz	-0.5
0	0	0	1	200MHz	-0.5
0	0	1	0	100MHz	No spread
0	0	1	1	Reserved	
0	1	0	0	100MHz	-1
0	1	0	1	200MHz	-1
0	1	1	0	Reserved	
0	1	1	1	Reserved	
1	0	0	0	100MHz	-1.5
1	0	0	1	200MHz	-1.5
1	0	1	0	Reserved	
1	0	1	1	Reserved	
1	1	0	0	Reserved	
1	1	0	1	200MHz	No spread
1	1	1	0	Reserved	
1	1	1	1	Reserved	

## Pin Descriptions

VFQFPN Pin Number	TSSOP Pin Number	Pin Name	Pin Type	Pin Description
16	1	S0	Input	Select pin 0. See Table1. Internal pull-up resistor.
1	2	S1	Input	Select pin 1. See Table 1. Internal pull-up resistor.
2	3	SS0	Input	Spread Select pin 0. See Table 2. Internal pull-up resistor.
3	4	X1/ICLK	Input	Crystal or clock input. Connect to a 25 MHz crystal or single ended clock.
4	5	X2	Output	Crystal connection. Leave unconnected for clock input.
5	6	OE	Input	Output enable. Tri-states outputs and device is not shut down. Internal pull-up resistor.
6	7	GNDXD	Power	Connect to ground.
7	8	SS1	Input	Spread Select pin 1. See Table 2. Internal pull-up resistor.
8	9	IREF	Output	Precision resistor attached to this pin is connected to the internal current reference.
9	10	CLK1	Output	HCSL complementary clock output 1.
10	11	CLK1	Output	HCSL true clock output 1.
11	12	VDDODA	Power	Connect to voltage supply +3.3 V for output driver and analog circuits
12	13	GNDODA	Power	Connect to ground.
13	14	CLK0	Output	HCSL complementary clock output 0.
14	15	CLK0	Output	HCSL true clock output 0.
15	16	VDDXD	Power	Connect to voltage supply +3.3 V for crystal oscillator and digital circuit.

## Applications Information

### External Components

A minimum number of external components are required for proper operation.

### Decoupling Capacitors

Decoupling capacitors of 0.01  $\mu\text{F}$  should be connected between each VDD pin and the ground plane, as close to the VDD pin as possible. Do not share ground vias between components. Route power from power source through the capacitor pad and then into ICS pin.

### Crystal

A 25 MHz fundamental mode parallel resonant crystal should be used. This crystal must have less than 300 ppm of error across temperature in order for the IDT5V41065 to meet PCI Express specifications.

### Crystal Capacitors

Crystal capacitors are connected from pins X1 to ground and X2 to ground to optimize the accuracy of the output frequency.

$C_L$  = Crystal's load capacitance in pF

Crystal Capacitors (pF) =  $(C_L - 8) * 2$

For example, for a crystal with a 16 pF load cap, each external crystal cap would be 16 pF.  $(16 - 8) * 2 = 16$ .

Current Source (Iref) Reference Resistor -  $R_R$

If board target trace impedance (Z) is 50  $\Omega$ , then  $R_R = 475 \Omega$  (1%), providing IREF of 2.32 mA. The output current ( $I_{OH}$ ) is equal to 6\*IREF.

### Output Termination

The PCI-Express differential clock outputs of the IDT5V41065 are open source drivers and require an external series resistor and a resistor to ground. These resistor values and their allowable locations are shown in detail in the **PCI-Express Layout Guidelines** section.

The IDT5V41065 can also be configured for LVDS compatible voltage levels. See the **LVDS Compatible Layout Guidelines** section.

## Output Structures

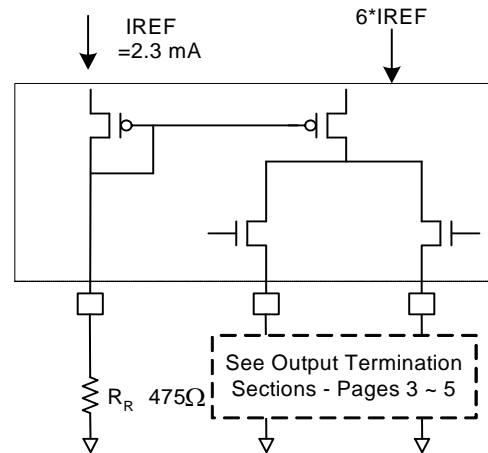

## General PCB Layout Recommendations

For optimum device performance and lowest output phase noise, the following guidelines should be observed.

1. Each 0.01  $\mu\text{F}$  decoupling capacitor should be mounted on the component side of the board as close to the VDD pin as possible.
2. No vias should be used between decoupling capacitor and VDD pin.
3. The PCB trace to VDD pin should be kept as short as possible, as should the PCB trace to the ground via. Distance of the ferrite bead and bulk decoupling from the device is less critical.
4. An optimum layout is one with all components on the same side of the board, minimizing vias through other signal layers (any ferrite beads and bulk decoupling capacitors can be mounted on the back). Other signal traces should be routed away from the IDT5V41065. This includes signal traces just underneath the device, or on layers adjacent to the ground plane layer used by the device.

## Layout Guidelines

SRC Reference Clock			
Common Recommendations for Differential Routing	Dimension or Value	Unit	Figure
L1 length, route as non-coupled 50ohm trace	0.5 max	inch	1
L2 length, route as non-coupled 50ohm trace	0.2 max	inch	1
L3 length, route as non-coupled 50ohm trace	0.2 max	inch	1
Rs	33	ohm	1
Rt	49.9	ohm	1

Down Device Differential Routing			
L4 length, route as coupled microstrip 100ohm differential trace	2 min to 16 max	inch	1
L4 length, route as coupled stripline 100ohm differential trace	1.8 min to 14.4 max	inch	1

Differential Routing to PCI Express Connector			
L4 length, route as coupled microstrip 100ohm differential trace	0.25 to 14 max	inch	2
L4 length, route as coupled stripline 100ohm differential trace	0.225 min to 12.6 max	inch	2

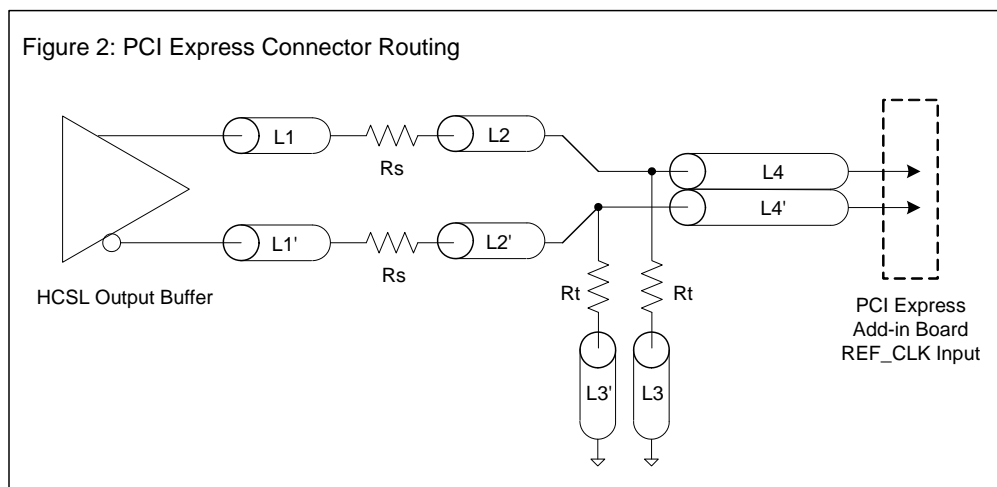
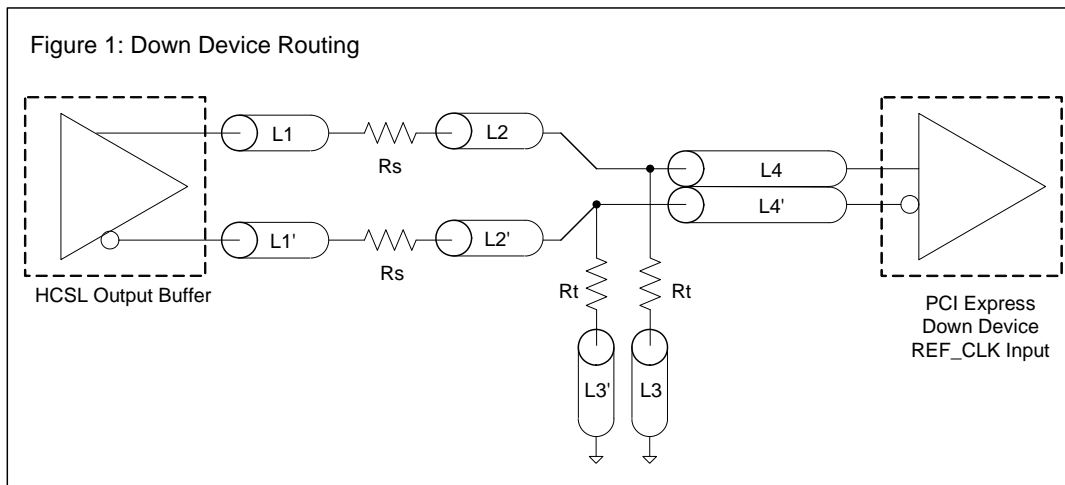

**Alternative Termination for LVDS and other Common Differential Signals (figure 3)**

Vdiff	Vp-p	Vcm	R1	R2	R3	R4	Note
0.45v	0.22v	1.08	33	150	100	100	
0.58	0.28	0.6	33	78.7	137	100	
0.80	0.40	0.6	33	78.7	none	100	ICS874003i-02 input compatible
0.60	0.3	1.2	33	174	140	100	Standard LVDS

R1a = R1b = R1

R2a = R2b = R2

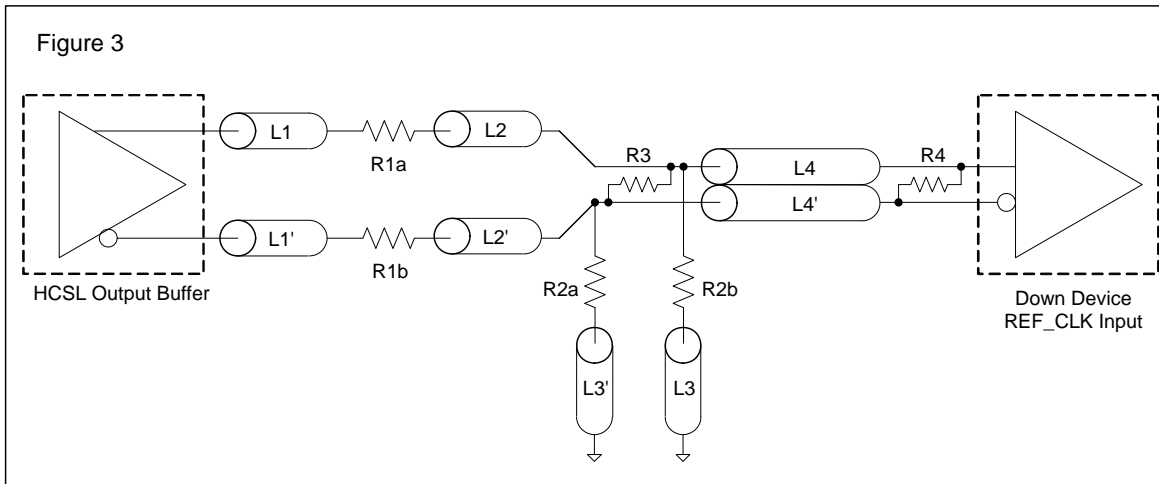

**Cable Connected AC Coupled Application (figure 4)**

Component	Value	Note
R5a, R5b	8.2K 5%	
R6a, R6b	1K 5%	
Cc	0.1 $\mu$ F	
Vcm	0.350 volts	

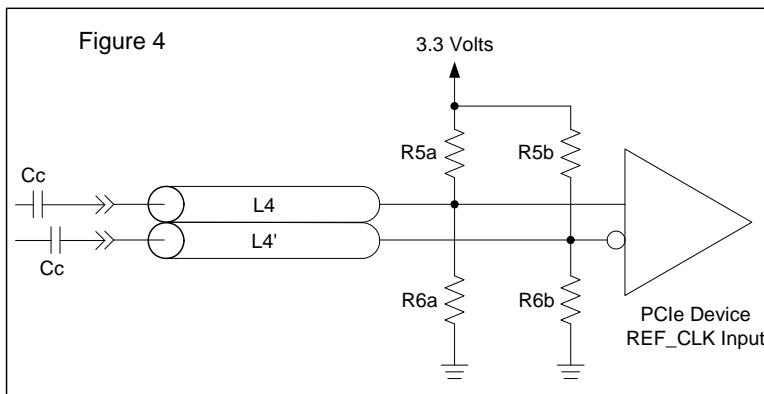

### Typical PCI-Express (HCSL) Waveform

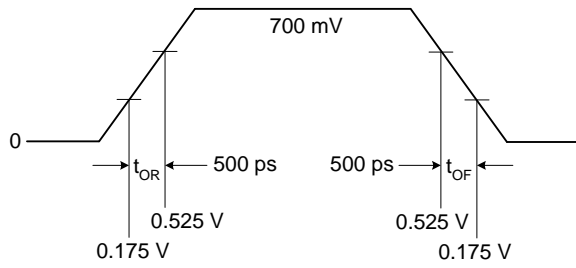

### Typical LVDS Waveform

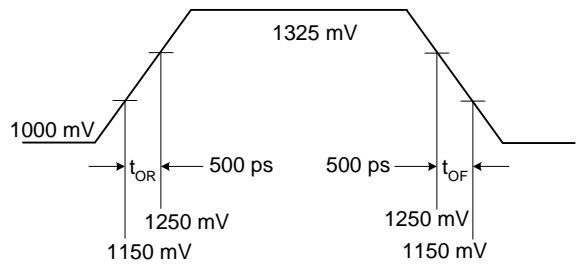

## Absolute Maximum Ratings

Stresses above the ratings listed below can cause permanent damage to the IDT5V41065. These ratings are stress ratings only. Functional operation of the device at these or any other conditions above those indicated in the operational sections of the specifications is not implied. Exposure to absolute maximum rating conditions for extended periods can affect product reliability. Electrical parameters are guaranteed only over the recommended operating temperature range.

Item	Rating
Supply Voltage, VDDXD, VDDODA	4.6 V
All Inputs and Outputs	-0.5 V to VDD+0.5 V
Ambient Operating Temperature (commercial)	0 to +70°C
Ambient Operating Temperature (industrial)	-40 to +85°C
Storage Temperature	-65 to +150°C
Junction Temperature	125°C
Soldering Temperature	260°C
ESD Protection (Input)	2000 V min. (HBM)

## DC Electrical Characteristics

Unless stated otherwise, VDD = 3.3 V  $\pm$ 5%, Ambient Temperature -40 to +85°C

Parameter	Symbol	Conditions	Min.	Typ.	Max.	Units
Supply Voltage	V		3.135	3.3	3.465	V
Input High Voltage <sup>1</sup>	V <sub>IH</sub>	S0, S1, OE, ICLK, SS0, SS1	2.2		VDD +0.3	V
Input Low Voltage <sup>1</sup>	V <sub>IL</sub>	S0, S1, OE, ICLK, SS0, SS1	VSS-0.3		0.8	V
Input Leakage Current <sup>2</sup>	I <sub>IL</sub>	0 < V <sub>in</sub> < VDD	-5		5	$\mu$ A
Operating Supply Current @ 100 MHz	I <sub>DD</sub>	R <sub>S</sub> =33 $\Omega$ , R <sub>P</sub> =50 $\Omega$ , C <sub>L</sub> =2 pF		63	85	mA
	I <sub>DDOE</sub>	OE =Low		42	50	mA
Input Capacitance	C <sub>IN</sub>	Input pin capacitance			7	pF
Output Capacitance	C <sub>OUT</sub>	Output pin capacitance			6	pF
X1, X2 Capacitance	C <sub>INX</sub>				5	pF
Pin Inductance	L <sub>PIN</sub>				5	nH
Output Impedance	Z <sub>O</sub>	CLK outputs	3.0			k $\Omega$
Pull-up Resistor	R <sub>PU</sub>	S0, S1, OE, SS0, SS1		100		k $\Omega$

1. Single edge is monotonic when transitioning through region.
2. Inputs with pull-ups/-downs are not included.

## AC Electrical Characteristics - CLK0/CLK1, $\overline{\text{CLK0/CLK1}}$

Unless stated otherwise, VDD=3.3 V  $\pm$ 5%, Ambient Temperature -40 to +85°C

Parameter	Symbol	Conditions	Min.	Typ.	Max.	Units
Input Frequency				25		MHz
Output Frequency		HCSL termination	25		200	MHz
		LVDS termination	25		100	MHz
Output High Voltage <sup>1,2</sup>	V <sub>OH</sub>	HCSL			850	mV
Output Low Voltage <sup>1,2</sup>	V <sub>OL</sub>	HCSL	-150			mV
Crossing Point Voltage <sup>1,2</sup>		Absolute	250		550	mV
Crossing Point Voltage <sup>1,2,4</sup>		Variation over all edges			140	mV
Jitter, Cycle-to-Cycle <sup>1,3</sup>					100	ps
Frequency Synthesis Error		All outputs		0		ppm
Modulation Frequency		Spread spectrum	30	32.9	33	kHz
Rise Time <sup>1,2</sup>	t <sub>OR</sub>	From 0.175 V to 0.525 V	175		700	ps
Fall Time <sup>1,2</sup>	t <sub>OF</sub>	From 0.525 V to 0.175 V	175		700	ps
Rise/Fall Time Variation <sup>1,2</sup>					125	ps
Output to Output Skew					50	ps
Duty Cycle <sup>1,3</sup>			45		55	%
Output Enable Time <sup>5</sup>		All outputs		50	100	ns
Output Disable Time <sup>5</sup>		All outputs		50	100	ns
Stabilization Time	t <sub>STABLE</sub>	From power-up VDD=3.3 V			1.8	ms
Spread Spectrum Transition Time	t <sub>SPREAD</sub>	Stabilization time after spread spectrum changes	7		30	ms

Note 1: Test setup is R<sub>S</sub>=33Ω, R<sub>P</sub>=50Ω with C<sub>L</sub>=2 pF, R<sub>r</sub> = 475Ω (1%).

Note 2: Measurement taken from a single-ended waveform.

Note 3: Measurement taken from a differential waveform.

Note 4: Measured at the crossing point where instantaneous voltages of both CLK and  $\overline{\text{CLK}}$  are equal.

Note 5: CLK pins are tri-stated when OE is low asserted. CLK is driven differential when OE is high.

## Electrical Characteristics - Differential Phase Jitter

Parameter	Symbol	Conditions	Min	Typ	Max	Units	Notes
Jitter, Phase	t <sub>jphasePLL</sub>	PCIe Gen1		32	86	ps (p-p)	1,2,3
	t <sub>jphaseLO</sub>	PCIe Gen2, 10 kHz < f < 1.5 MHz		0.8	3	ps (RMS)	1,2,3
	t <sub>jphaseHIGH</sub>	PCIe Gen2, 1.5 MHz < f < Nyquist (50 MHz)		2.3	3.1	ps (RMS)	1,2,3

Note 1. Guaranteed by design and characterization, not 100% tested in production.

Note 2. See <http://www.pcisig.com> for complete specs.

Note 3: Applies to 100MHz, spread off and 0.5% down spread only.

## Thermal Characteristics (16TSSOP)

Parameter	Symbol	Conditions	Min.	Typ.	Max.	Units
Thermal Resistance Junction to Ambient	$\theta_{JA}$	Still air		78		°C/W
	$\theta_{JA}$	1 m/s air flow		70		°C/W
	$\theta_{JA}$	3 m/s air flow		68		°C/W
Thermal Resistance Junction to Case	$\theta_{JC}$			37		°C/W

## Thermal Characteristics(16VFQFPN)

Parameter	Symbol	Conditions	Min.	Typ.	Max.	Units
Thermal Resistance Junction to Ambient	$\theta_{JA}$	Still air		63.2		°C/W
	$\theta_{JA}$	1 m/s air flow		55.9		°C/W
	$\theta_{JA}$	3 m/s air flow		51.4		°C/W
Thermal Resistance Junction to Case	$\theta_{JC}$			65.8		°C/W

### Marking Diagram (5V41065PGG)

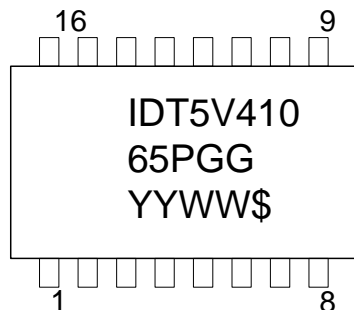

### Marking Diagram (5V41065PGGI)

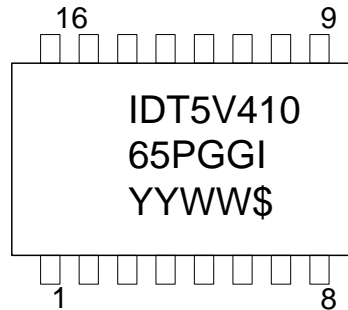

Notes:

1. Line 1 and 2: IDT part number.
2. Line 3: YYWW – Date code; \$ – Assembly location.
3. “G” after the two-letter package code designates RoHS compliant package.
4. “I” at the end of part number indicates industrial temperature range.
5. Bottom marking: country of origin if not USA.

### Marking Diagram (5V41065NLGI)

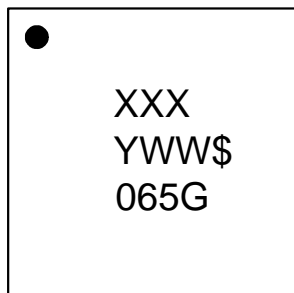

### Marking Diagram (5V41065NLGI)

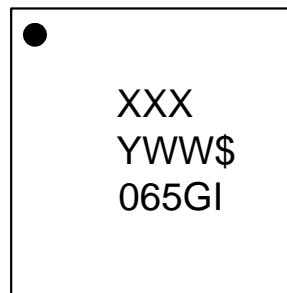

Notes:

1. Line 1: Lot number.
2. Line 2: YWW – Date code; \$ – Assembly location.
3. “G” designates RoHS compliant package.
4. “I” at the end of part number indicates industrial temperature range.

REVISIONS	
REV	DESCRIPTION
00	INITIAL RELEASE
01	COMBINE P00 & LAND PATT1

PIN #1 IDENTIFICATION

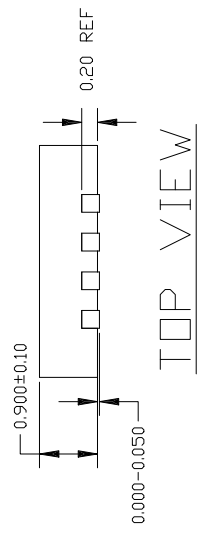
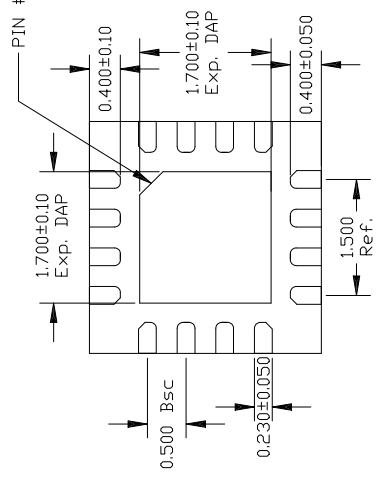
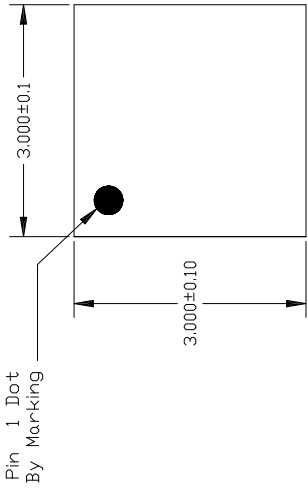

16LD QFN 3X3 (0.5MM PITCH)

TOLERANCES UNLESS SPECIFIED	DECIMAL	±
	ANGULAR	±
APPROVALS	DATE	TITLE
DRAWN /24C/12/15/08		NI/NI/GIT
CHECKED		3.0 x 3.0
		0.5 mm
		SIZE
		C
		DRAWING No.
		P
		DO NOT SCALE DRAWING

REVISIONS	
REV	DESCRIPTION
00	INITIAL RELEASE
01	COMBINE POD & LAND PATTERN

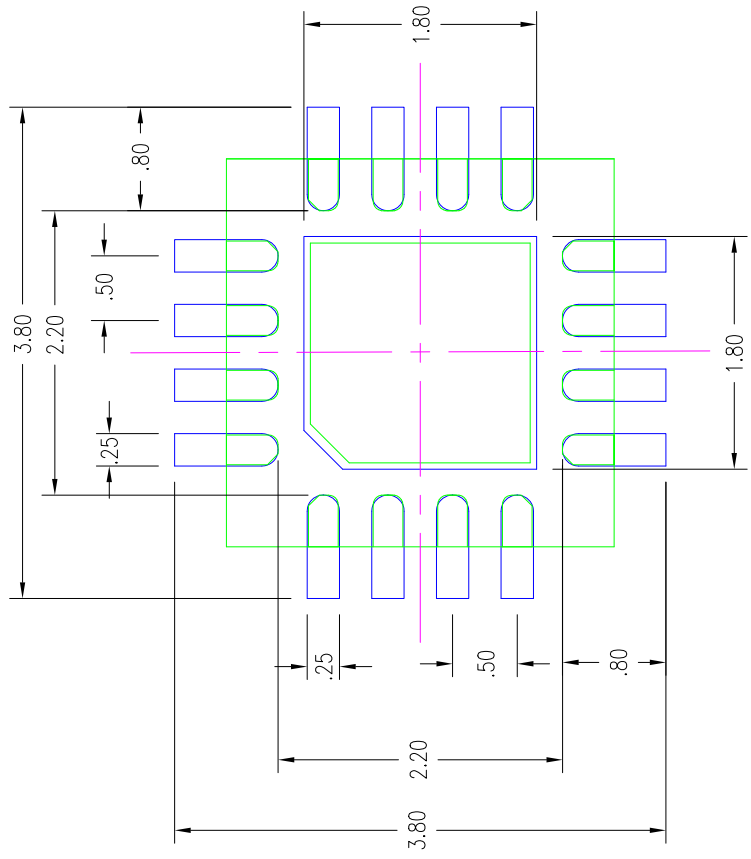

- NOTES:
1. ALL DIMENSION ARE IN .mm, ANGLES IN DEGREES.
  2. TOP DOWN VIEW, AS VIEWED ON PCB.
  3. COMPONENT OUTLINE SHOW FOR REFERENCE IN GREEN.
  4. LAND PATTERN IN BLUE. NSMD PATTERN ASSUMED.
  5. LAND PATTERN RECOMMENDATION PER IPC-7351B GENERIC REQUIREMENT FOR SURFACE MOUNT DESIGN AND LAND PATTERN.

TOLERANCES UNLESS SPECIFIED IN DECIMAL PLACE #	APPROVALS	DATE	TITLE
	XXXX	10/15/08	NU/NLG16
XXXX	CHECKED		3.0 x 3.0
			0.5 mm P
			SIZE
			DRAWING No.
			C
			P
			DO NOT SCALE DRAW

www.IDT.com

DATE	REV	DESCRIPTION
06/25/94	02	ADD
07/10/99	03	ADD T
5/23/01	04	ADDED T
10/14/04	05	ADD "GREEN"
3/8/13	06	ADDED
9/3/14	07	ADD TOLERANC
3/10/17	08	ADD

NOTE: REFER TO DCP FOR OF

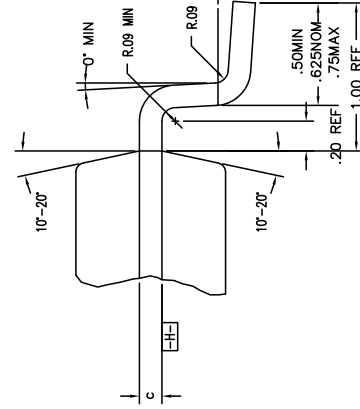
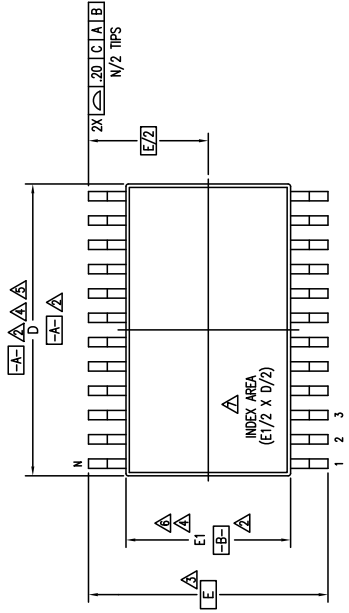

DETAIL B

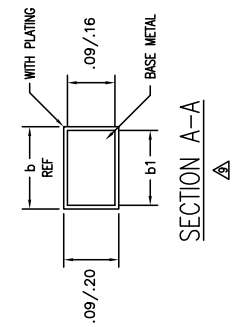
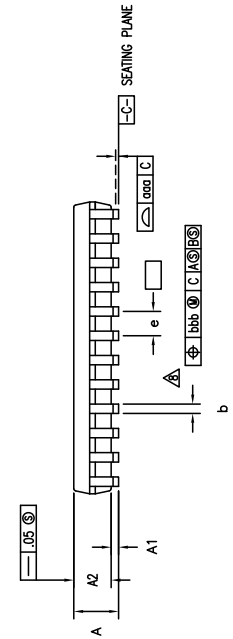
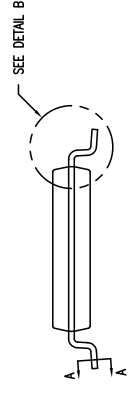

TOLERANCES UNLESS SPECIFIED DIMENSIONAL XXXX XXXX XXXX	ID WWW.IDT.CO	TITLE PC/PGC P (PC OR P 4.4 mm BODY)
	SIZE C	DRAWING No F

DO NOT SCALE DRAWING

DATE CREATED	REV
06/25/06	02
07/10/09	03
5/23/01	04
10/14/04	05
3/9/13	06
9/3/14	07
3/10/17	08

NOTE: REFER TO DCP FOR

SYMBOL	PG/PG68			PG/PG14			PG/PG16			PG/PG20			PG/PG24			PG/PG28		
	JEDEC VARIATION			JEDEC VARIATION			JEDEC VARIATION			JEDEC VARIATION			JEDEC VARIATION			JEDEC VARIATION		
	MIN	NOM	MAX	MIN	NOM	MAX	MIN	NOM	MAX	MIN	NOM	MAX	MIN	NOM	MAX	MIN	NOM	MAX
A	.85	1.10	1.20	.85	1.10	1.20	.85	1.10	1.20	.85	1.10	1.20	.85	1.10	1.20	.85	1.10	1.20
A1	.05	.10	.15	.05	.10	.15	.05	.10	.15	.05	.10	.15	.05	.10	.15	.05	.10	.15
A2	.80	1.00	1.05	.80	1.00	1.05	.80	1.00	1.05	.80	1.00	1.05	.80	1.00	1.05	.80	1.00	1.05
D	2.90	3.00	3.10	4.5	4.90	5.00	5.10	4.5	4.90	5.00	5.10	4.5	4.90	5.00	5.10	4.5	4.90	5.00
E	6.20	6.40	6.60	3	6.20	6.40	6.60	3	6.20	6.40	6.60	3	6.20	6.40	6.60	3	6.20	6.40
E1	4.30	4.40	4.50	4,6	4.30	4.40	4.50	4,6	4.30	4.40	4.50	4,6	4.30	4.40	4.50	4,6	4.30	4.40
e	.65 BSC			.65 BSC			.65 BSC			.65 BSC			.65 BSC			.65 BSC		
b	.19	.25	.30	.19	.25	.30	.19	.25	.30	.19	.25	.30	.19	.25	.30	.19	.25	.30
b1	.19	.22	.25	.19	.22	.25	.19	.22	.25	.19	.22	.25	.19	.22	.25	.19	.22	.25
aaa	-	-	.10	-	-	.10	-	-	.10	-	-	.10	-	-	.10	-	-	.10
bbb	-	-	.10	-	-	.10	-	-	.10	-	-	.10	-	-	.10	-	-	.10
N	8			14			16			20			24			28		

NOTES:

- ALL DIMENSIONING AND TOLERANCING CONFORM TO ASME Y14.5M-1994
- DATUMS **-A-** AND **-B-** TO BE DETERMINED AT DATUM PLANE **-H-**
- DIMENSION E TO BE DETERMINED AT SEATING PLANE **-C-**
- DIMENSIONS D AND E1 ARE TO BE DETERMINED AT DATUM PLANE **-H-**
- DIMENSION D DOES NOT INCLUDE MOLD FLASH, PROTRUSIONS OR GATE BURRS. MOLD FLASH, PROTRUSIONS OR GATE BURRS SHALL NOT EXCEED .15 mm PER SIDE
- DIMENSION E1 DOES NOT INCLUDE INTERLEAD FLASH OR PROTRUSIONS. INTERLEAD FLASH OR PROTRUSIONS SHALL NOT EXCEED .25 mm PER SIDE
- DETAIL OF PIN 1 IDENTIFIER IS OPTIONAL BUT MUST BE LOCATED WITHIN THE ZONE INDICATED
- LEAD WIDTH DIMENSION DOES NOT INCLUDE DAMBAR PROTRUSION. ALLOWABLE DAMBAR PROTRUSION IS .08 mm IN EXCESS OF THE LEAD WIDTH DIMENSION AT MAXIMUM MATERIAL CONDITION. DAMBAR CANNOT BE LOCATED ON THE LOWER RADIUS OR THE FOOT
- THESE DIMENSIONS APPLY TO THE FLAT SECTION OF THE LEAD BETWEEN .10 AND .25 mm FROM THE LEAD TIP
- ALL DIMENSIONS ARE IN MILLIMETERS
- THIS OUTLINE CONFORMS TO JEDEC PUBLICATION 95 REGISTRATION MO-153, VARIATION AA, AB-1, AB, AC, AD & AE

SYMBOL	OPTION T1		
	PGG14T1		
	JEDEC VARIATION		
A	.90	1.10	1.20
A1	.05	.10	.15
A2	.80	1.00	1.05
D	4.90	5.00	5.10
E	6.20	6.40	6.60
E1	4.30	4.40	4.50
e	.65 BSC		
b	.19	.25	.30
b1	.19	.22	.25
c	.09	-	.20
aaa	-	-	.10
bbb	-	-	.10
N	14		

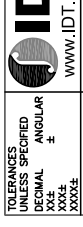

WWW.IDT.COM

TITLE PG/PG (PG OR 4.4 mm B) SIZE C DRAWING C DO NOT SCALE

DATE CREATED	REV
08/25/98	02
07/10/99	03
5/23/01	04
10/14/04	05
3/8/13	06
9/3/14	07
3/10/17	08

NOTE: REFER TO DCP FOR

LAND PATTERN DIMENSIONS

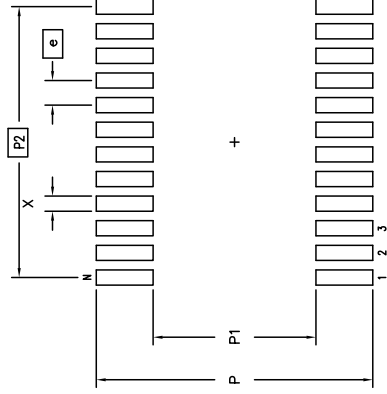

	MIN	MAX	MIN	MAX	MIN	MAX	MIN	MAX	MIN	MAX	MIN	MAX
P	7.20	7.40	7.20	7.40	7.20	7.40	7.20	7.40	7.20	7.40	7.20	7.40
P1	4.20	4.40	4.20	4.40	4.20	4.40	4.20	4.40	4.20	4.40	4.20	4.40
P2	1.95	BSC	3.90	BSC	4.55	BSC	5.85	BSC	7.15	BSC	8.45	BSC
X	.30	.50	.30	.50	.30	.50	.30	.50	.30	.50	.30	.50
e	.65	BSC	.65	BSC	.65	BSC	.65	BSC	.65	BSC	.65	BSC
N	8		14		16		20		24		28	

 TOLERANCES UNLESS SPECIFIED  
 DECIMAL ±  
 XXX ±.005  
 XXXX ±.0025  
 XXXX ±.0015  
 TITLE PG/PGS (PG OR 4.4 mm B) WWW.IDT.COM  
 SIZE DRAWING C  
 DO NOT SCALE

## Ordering Information

Part / Order Number	Marking	Shipping Packaging	Package	Temperature
5V41065PGG	See Page 11	Tubes	16-pin TSSOP	0 to +70° C
5V41065PGG8		Tape and Reel	16-pin TSSOP	0 to +70° C
5V41065PGGI		Tubes	16-pin TSSOP	-40 to +85° C
5V41065PGGI8		Tape and Reel	16-pin TSSOP	-40 to +85° C
5V41065NLG	See Page 11	Trays	16-pin QFN	0 to +70° C
5V41065NLG8		Tape and Reel	16-pin QFN	0 to +70° C
5V41065NLGI		Trays	16-pin QFN	-40 to +85° C
5V41065NLGI8		Tape and Reel	16-pin QFN	-40 to +85° C

“G” after the two-letter package code are the Pb-Free configuration, RoHS compliant.

While the information presented herein has been checked for both accuracy and reliability, Integrated Device Technology (IDT) assumes no responsibility for either its use or for the infringement of any patents or other rights of third parties, which would result from its use. No other circuits, patents, or licenses are implied. This product is intended for use in normal commercial applications. Any other applications such as those requiring extended temperature range, high reliability, or other extraordinary environmental requirements are not recommended without additional processing by IDT. IDT reserves the right to change any circuitry or specifications without notice. IDT does not authorize or warrant any IDT product for use in life support devices or critical medical instruments.

## Revision History

Rev.	Originator	Date	Description of Change
A		07/15/08	New datasheet; Preliminary initial release.
B	RDW	01/13/10	Added Gen2 to title; update Electrical tables per char; added Differential Phase Jitter table.
C	RDW	04/27/10	Updated electrical tables per char; VDD is now 3.3 ±5%; released to final.
D	RDW	07/19/10	1. Updated title and general description 2. Updated cycle-to-cycle jitter spec from 125 to 100 ps.
E	RDW	11/21/11	1. Changed title to “2 Output PCIe GEN1/2 Synthesizer” 2. Added note to Features section: “For PCIe Gen3 applications, see 5V41235” 3. Updated Differential Phase Jitter table.
F	J, Chao	08/26/13	1. Added 16VFQFPN notes in Features section 2. Added pinout and “Output/Spread Selection” table for 16VFQFPN. 3. Updated Pin Description table to include VFQFPN pin descriptions. 4. Added Thermal Characteristics table for 16VFQFPN. 5. Added marking diagrams for 16VFQFPN. 6. Added Package Dimensions/Drawing for 16VFQFPN. 7. Updated Ordering Information to include 16VFQFPN.
G	C.P.	04/17/17	1. Replaced package outline drawings with latest NLG16 and PGG16 drawings. 2. Updated legal disclaimer.

**IDT5V41065**

**2 OUTPUT PCIE GEN1/2 SYNTHESIZER**

## IMPORTANT NOTICE AND DISCLAIMER

RENESAS ELECTRONICS CORPORATION AND ITS SUBSIDIARIES (“RENESAS”) PROVIDES TECHNICAL SPECIFICATIONS AND RELIABILITY DATA (INCLUDING DATASHEETS), DESIGN RESOURCES (INCLUDING REFERENCE DESIGNS), APPLICATION OR OTHER DESIGN ADVICE, WEB TOOLS, SAFETY INFORMATION, AND OTHER RESOURCES “AS IS” AND WITH ALL FAULTS, AND DISCLAIMS ALL WARRANTIES, EXPRESS OR IMPLIED, INCLUDING, WITHOUT LIMITATION, ANY IMPLIED WARRANTIES OF MERCHANTABILITY, FITNESS FOR A PARTICULAR PURPOSE, OR NON-INFRINGEMENT OF THIRD-PARTY INTELLECTUAL PROPERTY RIGHTS.

These resources are intended for developers who are designing with Renesas products. You are solely responsible for (1) selecting the appropriate products for your application, (2) designing, validating, and testing your application, and (3) ensuring your application meets applicable standards, and any other safety, security, or other requirements. These resources are subject to change without notice. Renesas grants you permission to use these resources only to develop an application that uses Renesas products. Other reproduction or use of these resources is strictly prohibited. No license is granted to any other Renesas intellectual property or to any third-party intellectual property. Renesas disclaims responsibility for, and you will fully indemnify Renesas and its representatives against, any claims, damages, costs, losses, or liabilities arising from your use of these resources. Renesas' products are provided only subject to Renesas' Terms and Conditions of Sale or other applicable terms agreed to in writing. No use of any Renesas resources expands or otherwise alters any applicable warranties or warranty disclaimers for these products.

(Disclaimer Rev.1.01 Jan 2024)

### Corporate Headquarters

TOYOSU FORESIA, 3-2-24 Toyosu,  
Koto-ku, Tokyo 135-0061, Japan  
[www.renesas.com](http://www.renesas.com)

### Trademarks



Renesas and the Renesas logo are trademarks of Renesas Electronics Corporation. All trademarks and registered trademarks are the property of their respective owners.

### Contact Information

For further information on a product, technology, the most up-to-date version of a document, or your nearest sales office, please visit [www.renesas.com/contact-us/](http://www.renesas.com/contact-us/).

## Looking for pricing, stock, or lifecycle information?

Click below to explore more details on WIN SOURCE:

-  [View 5V41065PGG on WIN SOURCE](#)
-  [Renesas Electronics America](#) Information

## Optimize Your Supply Chain with WIN SOURCE Solutions

-  Global Sourcing Solution
-  Obsolete Management
-  Cost Control Management
-  Shortage Management
-  Alternative Solution
-  Excess Inventory Management