



THE DATASHEET OF DS2740BU+



FEATURES

- 15-Bit Bidirectional Current Measurement (DS2740U)
 - 1.56 μ V LSB and \pm 51.2mV Dynamic Range
 - 78 μ A LSB and \pm 2.56A Dynamic Range with External 20m Ω Sense Resistor (R_{SNS})
 - 156 μ A LSB and \pm 5.12A Dynamic Range with External 10m Ω Sense Resistor (R_{SNS})
- 13-Bit Bidirectional Current Measurement (DS2740BU)
 - 6.25 μ V LSB and \pm 51.2mV Dynamic Range
 - 312 μ A LSB and \pm 2.56A Dynamic Range with External 20m Ω Sense Resistor (R_{SNS})
 - 625 μ A LSB and \pm 5.12A Dynamic Range with External 10m Ω Sense Resistor (R_{SNS})
- Analog Input Filter (IS1, IS2) Extends Dynamic Range for Pulse-Load Applications
- Current Accumulation Register Resolution
 - 6.25 μ Vhr (Both DS2740U and DS2740BU)
 - 0.3125mAh with External 20m Ω R_{SNS}
 - 0.6250mAh with External 10m Ω R_{SNS}
- Dallas 1-Wire[®] Interface
 - Unique 64-Bit Device Address
 - Standard and Overdrive Timings (OVD)
- Low Power Consumption:
 - Active Current: 65 μ A max
 - Sleep Current: 1 μ A max

PIN CONFIGURATION

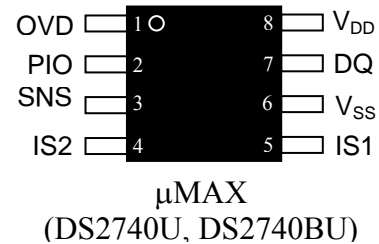

*See Table 1 for Ordering Information.
See Table 2 for Detailed Pin Descriptions.*

PIN DESCRIPTION

- OVD - 1-Wire Bus Speed Select
- PIO - Programmable I/O Pin
- SNS - Sense Resistor Input
- IS2 - Current-Sense Input
- IS1 - Current-Sense Input
- V_{SS} - Device Ground, Current-Sense Resistor Return
- DQ - Data Input/Output
- V_{DD} - Power-Supply Input (2.7V to 5.5V)

1-Wire is a registered trademark of Dallas Semiconductor.

Table 1. ORDERING INFORMATION

PART	MARKING	DESCRIPTION
DS2740U	D2740	15-Bit Current Resolution, 8-Pin μ MAX
DS2740U+	D2740 (see note)	15-Bit Current Resolution, Lead-Free 8-Pin μ MAX
DS2740U/T&R	D2740	15-Bit Current Resolution, 8-Pin μ MAX, Tape-and-Reel
DS2740U+T&R	D2740 (see note)	15-Bit Current Resolution, Lead-Free 8-Pin μ MAX, Tape-and-Reel
DS2740BU	2740B	13-Bit Current Resolution, 8-Pin μ MAX
DS2740BU+	2740B (see note)	13-Bit Current Resolution, Lead-Free 8-Pin μ MAX
DS2740BU/T&R	2740B	13-Bit Current Resolution, 8-Pin μ MAX, Tape-and-Reel
DS2740BU+T&R	2740B (see note)	13-Bit Current Resolution, Lead-Free 8-Pin μ MAX, Tape-and-Reel

Note: A “+” will also be marked on the package next to the pin 1 indicator.

DESCRIPTION

The DS2740 provides high-precision current-flow measurement data to support battery-capacity monitoring in cost-sensitive applications. Current is measured bidirectionally over a dynamic range of 15 bits (DS2740U) or 13 bits (DS2740BU), with the net flow accumulated in a separate 16-bit register. Through its 1-Wire interface, the DS2740 allows the host system read/write access to status and current measurement registers. Each device has a unique factory-programmed 64-bit net address that allows it to be individually addressed by the host system, supporting multibattery slot operation. The interface can be operated with standard or overdrive timing.

Although the DS2740 is primarily intended for location on the host system, it is also suited for mounting in the battery pack. The DS2740 and FuelPack™ algorithms, along with host measurements of temperature and voltage, form a complete and accurate solution for estimating remaining capacity.

Figure 1. BLOCK DIAGRAM

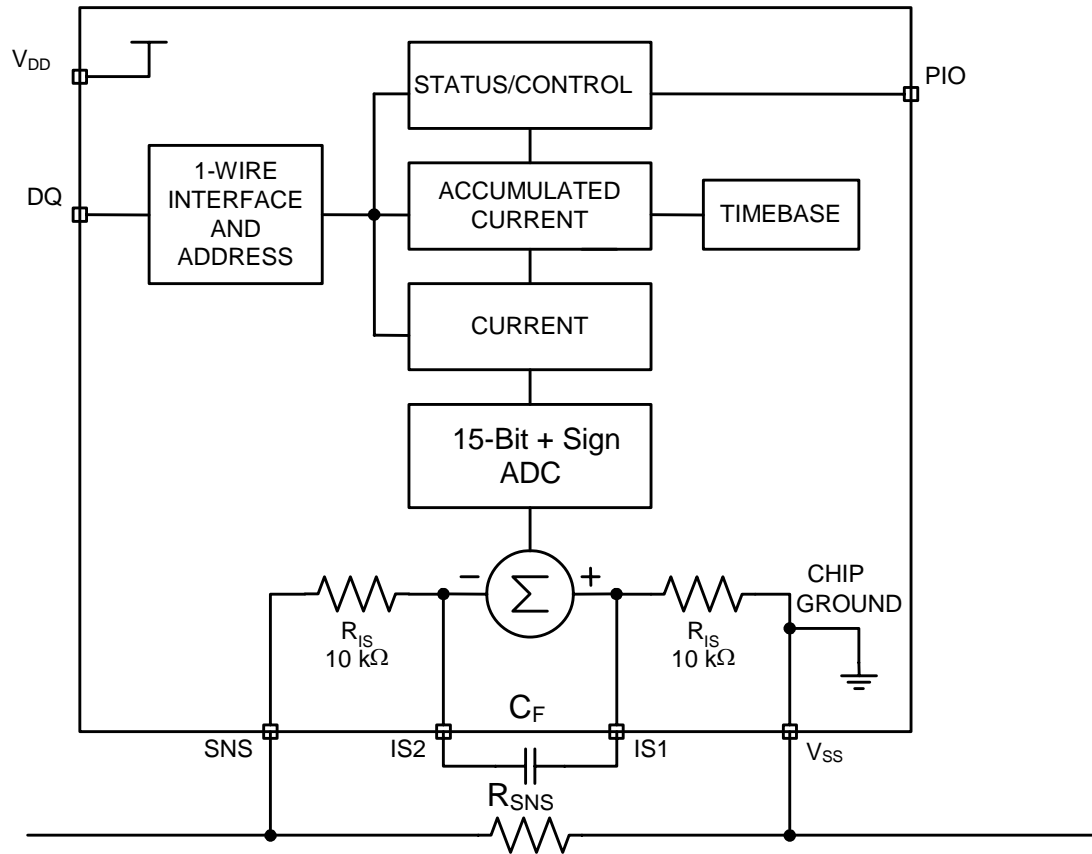
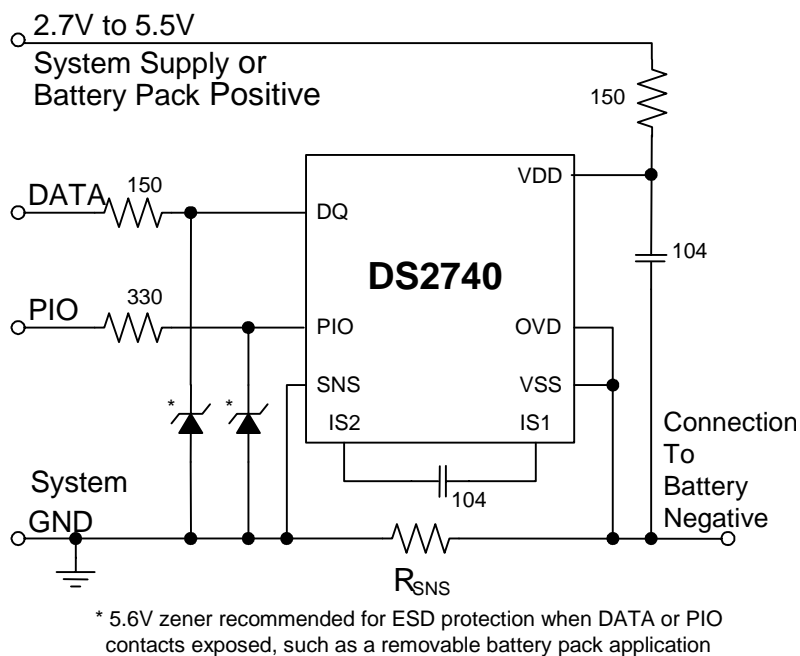

Table 2. DETAILED PIN DESCRIPTIONS

PIN	SYMBOL	DESCRIPTION
OVD	1	1-Wire Bus Speed Control. Input logic level selects the speed of the 1-Wire bus. Logic 1 selects overdrive (OVD) and Logic 0 selects standard timing (STD). On a multidrop bus, all devices must operate at same speed.
PIO	2	Programmable I/O Pin. Programmed as input or output through internal registers. Open-drain output sufficient for LED or vibrator activation.
SNS	3	Current-Sense Resistor Input
IS2	4	Current-Sense Input. Connected to SNS through a 10k Ω resistor to allow filtering of the current waveform by an external capacitor.
IS1	5	Current-Sense Input. Connected to V _{SS} through a 10k Ω resistor to allow filtering of the current waveform through an external capacitor.
V _{SS}	6	Device Ground, Current-Sense Resistor Return. Connect directly to the negative terminal of the battery cell.
DQ	7	Data I/O Pin. Operates bidirectionally with open-drain output driver. Internal 1 μ A pulldown aids in sensing pack removal and Sleep-mode activation.
V _{DD}	8	Power-Supply Input. Connects to system voltage supply or positive terminal of battery cell.

Figure 2. APPLICATION EXAMPLE

POWER MODES

The DS2740 has two power modes: Active and Sleep. While in Active mode, the DS2740 operates as a high-precision coulomb counter with current and accumulated current measurement blocks operating continuously and the resulting values updated in the measurement registers. Read and write access is allowed to all registers. PIO pin is active. In Sleep mode, the DS2740 operates in a low-power mode with no current measurement activity. Serial access to current, accumulated current, and status/control registers is allowed if $V_{DD} > 2V$.

The DS2740 operating mode transitions from SLEEP to ACTIVE when:

- 1) $DQ > V_{IH}$, and $V_{DD} > UV$ threshold, or
- 2) V_{DD} rises from below UV threshold to above UV threshold.

The DS2740 operating mode transitions from ACTIVE to SLEEP when:

- 1) V_{DD} falls to UV threshold, or
- 2) $SMOD = 1$ and $DQ < V_{IL}$ for 2s.

CURRENT MEASUREMENT

In the Active mode of operation, the DS2740 continually measures the current flow into and out of the battery by measuring the voltage drop across a low-value current-sense resistor, R_{SNS} . To extend the input range for pulse-type load currents, the voltage signal can be filtered by adding a capacitor between the IS1 and IS2 pins. The external capacitor and two internal resistors form a lowpass filter at the input of the ADC. The voltage-sense range at IS1 and IS2 is $\pm 51.2mV$. The input converts peak signal amplitudes up to $102mV$ as long as the continuous or average signal level (post filter) does not exceed $\pm 51.2mV$ over the conversion cycle period. The ADC samples the input differentially at IS1 and IS2 with an $18.6kHz$ sample clock and updates the current register at the completion of each conversion cycle. Conversion times for each resolution option are listed in the tables below. Two resolution options are available. Figure 3 describes the current measurement register format and resolution for each option. “S” indicates the sign bit(s).

Figure 3. CURRENT REGISTER FORMAT

DS2740U: Units: $1.5625\mu V/R_{SNS}$, 15-bit + sign resolution, 3.5s conversion period.

DS2740BU: Units: $6.250\mu V/R_{SNS}$, 13-bit + sign resolution, 0.875s conversion period.

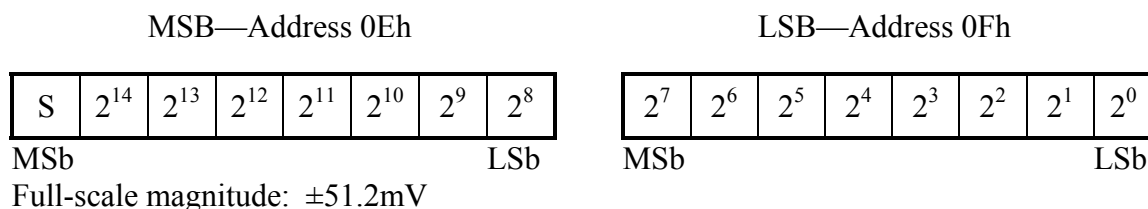

PART	CONVERSION TIME	CURRENT RESOLUTION (1 LSB)				
		$V_{IS1} - V_{IS2}$	R_{SNS}			
			20m Ω	15m Ω	10m Ω	5m Ω
DS2740U	3.515s	1.5625 μ V	78.13 μ A	104.2 μ A	156.3 μ A	312.5 μ A
DS2740BU	0.878s	6.250 μ V	312.5 μ A	416.7 μ A	625 μ A	1.250mA

Every 1024th conversion, the ADC measures its input offset to facilitate offset correction. Offset correction occurs approximately once per hour in the DS2740U and four times per hour in the DS2740BU. The resulting correction factor is applied to the subsequent 1023 measurements. During the offset correction conversion, the ADC does not measure the IS1 to IS2 signal. A maximum error of 1/1024 in the accumulated current register (ACR) is possible, however, to reduce the error, the current measurement just prior to the offset conversion is displayed in the current register and is substituted for the dropped current measurement in the current accumulation process. The typical error due to offset correction is much less than 1/1024.

CURRENT ACCUMULATOR

Current measurements are internally summed, or accumulated, at the completion of each conversion period with the results displayed in the ACR. The accuracy of the ACR is dependent on both the current measurement and the conversion timebase. The ACR has a range of $\pm 204.8\text{mVh}$ with a LSB of $6.25\mu\text{Vh}$. Additional registers hold fractional results of each accumulation, however, these bits are not user accessible.

Read and write access is allowed to the ACR. Whenever the ACR is written, fractional accumulation results are cleared. Also, a write forces the ADC to measure its offset and update the offset correction factor. The current measurement and accumulation begin with the second conversion following a write to the ACR. Figure 4 describes the ACR address, format, and resolution.

Figure 4. CURRENT ACCUMULATOR FORMAT

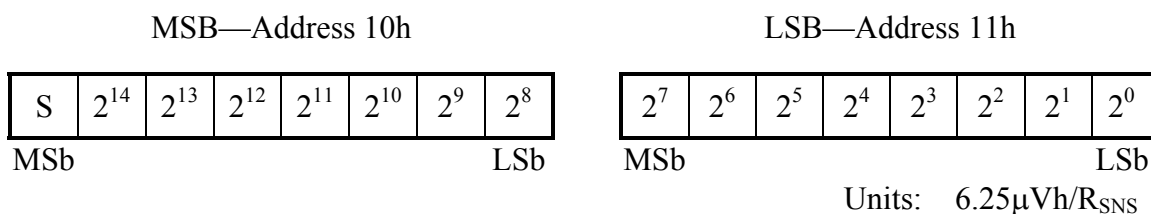

PART	UPDATE INTERVAL	ACR LSB				
		$V_{IS1} - V_{IS2}$	R_{SNS}			
			20m Ω	15m Ω	10m Ω	5m Ω
DS2740U	3.515s	6.25 μ Vh	312.5 μ Ah	416.7 μ Ah	625 μ Ah	1.250mAh
DS2740BU	0.878s					

PART	ACR RANGE				
	$V_{IS1} - V_{IS2}$	R_{SNS}			
		20m Ω	15m Ω	10m Ω	5m Ω
DS2740U	$\pm 204.8\text{mVh}$	$\pm 10.24\text{Ah}$	$\pm 13.65\text{Ah}$	$\pm 20.48\text{Ah}$	$\pm 40.96\text{Ah}$
DS2740BU					

MEMORY

The DS2740 has memory space with registers for instrumentation, status, and control. When the MSB of a two-byte register is read, both the MSB and LSB are latched and held for the duration of the Read Data command to prevent updates during the read and ensure synchronization between the two register bytes. For consistent results, always read the MSB and the LSB of a two-byte register during the same Read Data command sequence.

Table 3. MEMORY MAP

ADDRESS (HEX)	DESCRIPTION	READ/WRITE
00	Reserved	—
01	Status Register	R/W
02 to 07	Reserved	—
08	Special Feature Register	R/W
09 to 0D	Reserved	—
0E	Current Register MSB	R
0F	Current Register LSB	R
10	Accumulated Current Register MSB	R/W
11	Accumulated Current Register LSB	R/W
12 to FF	Reserved	—

STATUS REGISTER

The format of the status register is shown in Figure 5. The function of each bit is described in detail in the following paragraphs.

Figure 5. STATUS REGISTER FORMAT

ADDRESS 01h							
BIT 7	BIT 6	BIT 5	BIT 4	BIT 3	BIT 2	BIT 1	BIT 0
X	SMOD	X	RNAOP	X	X	X	X

SMOD—SLEEP Mode Enable. A value of 1 allows the DS2740 to enter Sleep mode when DQ is low for 2s. A value of 0 disables DQ related transitions to Sleep mode. The power-up default of SMOD = 0.

RNAOP—Read Net Address Opcode. A value of 0 in this bit sets the opcode for the Read Net Address command to 33h, while a 1 sets the opcode to 39h. The power-up default of RNAOP = 0.

X—Reserved bits.

SPECIAL FEATURE REGISTER

The format of the special feature register is shown in Figure 6. The function of each bit is described in detail in the following paragraphs.

Figure 6. SPECIAL FEATURE REGISTER FORMAT

ADDRESS 08h							
BIT 7	BIT 6	BIT 5	BIT 4	BIT 3	BIT 2	BIT 1	BIT 0
X	PIO	X	X	X	X	X	X

PIO—PIO Pin Sense and Control. This bit is read and write enabled. Writing a 0 to the PIO bit enables the PIO open-drain output driver, forcing the PIO pin low. Writing a 1 to the PIO bit disables the output driver, allowing the PIO pin to be pulled high or used as an input. Reading the PIO bit returns the logic level forced on the PIO pin. Note that if PIO is left floating, the weak pulldown brings the pin low. PIO resets to a 1 at initial power up, when the DS2740 enters Sleep mode, or $DQ\ low > t_{SLEEP}$ (independent of the SMOD pin).

X—Reserved Bits.

1-Wire BUS SYSTEM

The 1-Wire bus is a system that has a single bus master and one or more slaves. A multidrop bus is a 1-Wire bus with multiple slaves. A single-drop bus has only one slave device. In all instances, the DS2740 is a slave device. The bus master is typically a microprocessor in the host system. The discussion of this bus system consists of four topics: 64-bit net address, hardware configuration, transaction sequence, and 1-Wire signaling.

64-BIT NET ADDRESS

Each DS2740 has a unique, factory-programmed 1-Wire net address that is 64 bits in length. The first eight bits are the 1-Wire family code (36h for DS2740). The next 48 bits are a unique serial number. The last eight bits are a cyclic redundancy check (CRC) of the first 56 bits (see Figure 7). The 64-bit net address and the 1-Wire I/O circuitry built into the device enable the DS2740 to communicate through the 1-Wire protocol detailed in the *1-Wire Bus System* section of this data sheet.

Figure 7. 1-Wire NET ADDRESS FORMAT

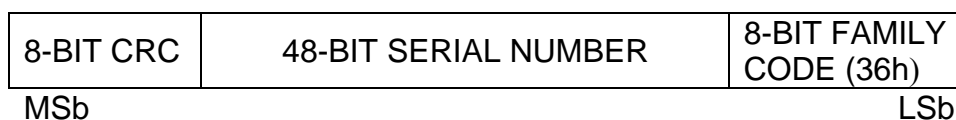

CRC GENERATION

The DS2740 has an 8-bit CRC stored in the most significant byte of its 1-Wire net address. To ensure error-free transmission of the address, the host system can compute a CRC value from the first 56 bits of the address and compare it to the CRC from the DS2740. The host system is responsible for verifying the CRC value and taking action as a result. The DS2740 does not compare CRC values and does not prevent a command sequence from proceeding as a result of a CRC mismatch. Proper use of the CRC can result in a communication channel with a very high level of integrity.

The CRC can be generated by the host using a circuit consisting of a shift register and XOR gates as shown in Figure 8, or it can be generated in software. Additional information about the Dallas 1-Wire CRC is available in Application Note 27, *Understanding and Using Cyclic Redundancy Checks with Dallas Semiconductor iButton Products*. (This application note can be found on the Maxim/Dallas Semiconductor website at www.maxim-ic.com.)

In the circuit in Figure 8, the shift register bits are initialized to 0. Then, starting with the least significant bit of the family code, one bit at a time is shifted in. After the 8th bit of the family code has been entered, then the serial number is entered. After the 48th bit of the serial number has been entered, the shift register contains the CRC value.

Figure 8. 1-Wire CRC GENERATION BLOCK DIAGRAM

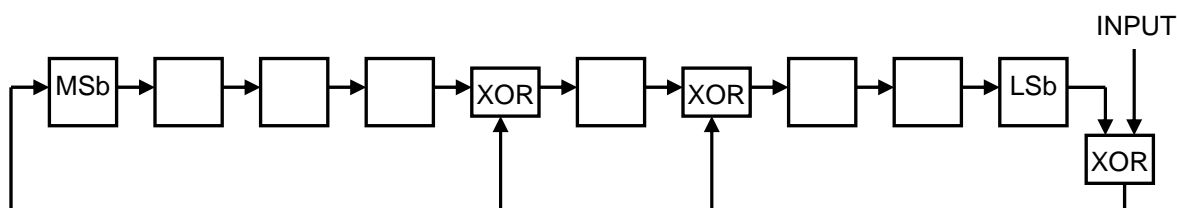

HARDWARE CONFIGURATION

Because the 1-Wire bus has only a single line, it is important that each device on the bus be able to drive it at the appropriate time. To facilitate this, each device attached to the 1-Wire bus must connect to the bus with open-drain or tri-state output drivers. The DS2740 uses an open-drain output driver as part of the bidirectional interface circuitry shown in Figure 9. If a bidirectional pin is not available on the bus master, separate output and input pins can be connected together.

The 1-Wire bus must have a pullup resistor at the bus-master end of the bus. For short line lengths, the value of this resistor should be approximately 5k Ω . The idle state for the 1-Wire bus is high. If, for any reason, a bus transaction must be suspended, the bus must be left in the idle state to properly resume the transaction later. If the bus is left low for more than 120 μ s (16 μ s for overdrive speed), slave devices on the bus begin to interpret the low period as a reset pulse, effectively terminating the transaction.

The DS2740 can operate in two communication speed modes, standard and overdrive. The speed mode is determined by the input logic level of the OVD pin with a logic 0 selecting standard Speed and a logic 1 selecting overdrive speed. The OVD pin must be at a stable logic level of 0 or 1 before initializing a transaction with a reset pulse. All 1-Wire devices on a multinode bus must operate at the same communication speed for proper operation. 1-Wire timing for both standard and overdrive speeds are listed in the *Electrical Characteristics: 1-Wire Interface* tables.

Figure 9. 1-Wire BUS INTERFACE CIRCUITRY

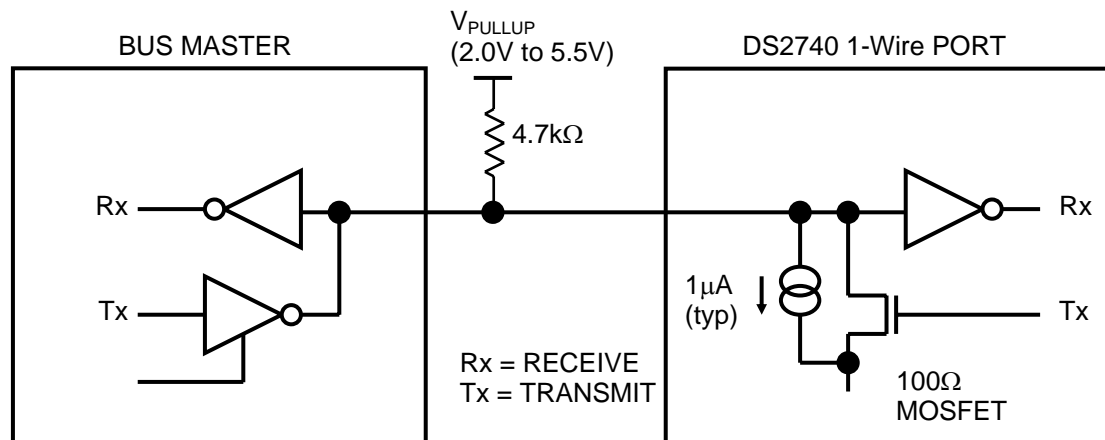

TRANSACTION SEQUENCE

The protocol for accessing the DS2740 through the 1-Wire port is as follows:

- Initialization
- Net Address Command
- Function Command
- Transaction/Data

The sections that follow describe each of these steps in detail.

All transactions of the 1-Wire bus begin with an initialization sequence consisting of a reset pulse transmitted by the bus master followed by a presence pulse simultaneously transmitted by the DS2740 and any other slaves on the bus. The presence pulse tells the bus master that one or more devices are on the bus and ready to operate. For more details, see the *1-Wire Signaling* section.

NET ADDRESS COMMANDS

Once the bus master has detected the presence of one or more slaves, it can issue one of the net address commands described in the following paragraphs. The name of each net address command is followed by the 8-bit opcode for that command in square brackets. Figure 10 presents a transaction flowchart of the net address commands.

Read Net Address [33h or 39h]. This command allows the bus master to read the DS2740's 1-Wire net address. This command can only be used if there is a single slave on the bus. If more than one slave is present, a data collision occurs when all slaves try to transmit at the same time (open drain produces a wired-AND result). The RNAOP bit in the status register selects the opcode for this command, with RNAOP = 0 indicating 33h, and RNAOP = 1 indicating 39h.

Match Net Address [55h]. This command allows the bus master to specifically address one DS2740 on the 1-Wire bus. Only the addressed DS2740 responds to any subsequent function command. All other slave devices ignore the function command and wait for a reset pulse. This command can be used with one or more slave devices on the bus.

Skip Net Address [CCh]. This command saves time when there is only one DS2740 on the bus by allowing the bus master to issue a function command without specifying the address of the slave. If more than one slave device is present on the bus, a subsequent function command can cause a data collision when all slaves transmit data at the same time.

Search Net Address [F0h]. This command allows the bus master to use a process of elimination to identify the 1-Wire net addresses of all slave devices on the bus. The search process involves the repetition of a simple three-step routine: read a bit, read the complement of the bit, then write the desired value of that bit. The bus master performs this simple three-step routine on each bit location of the net address. After one complete pass through all 64 bits, the bus master knows the address of one device. The remaining devices can then be identified on additional iterations of the process. See Chapter 5 of the *Book of DS19xx iButton® Standards* for a comprehensive discussion of a net address search, including an actual example. (This publication can be found on the Maxim/Dallas Semiconductor website at www.maxim-ic.com.)

Resume [A5h]. This command increases data throughput in multidrop environments where the DS2740 needs to be accessed several times. Resume is similar to the Skip Net Address command in that the 64-bit net address does not have to be transmitted each time the DS2740 is accessed. After successfully executing a Match Net Address command or Search Net Address command, an internal flag is set in the DS2740. When the flag is set, the DS2740 can be repeatedly accessed through the Resume command function. Accessing another device on the bus clears the flag, thus preventing two or more devices from simultaneously responding to the Resume command function.

FUNCTION COMMANDS

After successfully completing one of the net address commands, the bus master can access the features of the DS2740 with any of the function commands described in the following paragraphs and summarized in Table 4. The name of each function is followed by the 8-bit opcode for that command in square brackets.

Read Data [69h, XX]. This command reads data from the DS2740 starting at memory address XX. The LSB of the data in address XX is available to be read immediately after the MSb of the address has been entered. Because the address is automatically incremented after the MSb of each byte is received, the LSB of the data at address XX + 1 is available to be read immediately after the MSb of the data at address XX. If the bus master continues to read beyond address FFh, the DS2740 starts over at address 00h. Addresses labeled “Reserved” in the memory map contain undefined data. The Read Data command can be terminated by the bus master with a reset pulse at any bit boundary.

Write Data [6Ch, XX]. This command writes data to the DS2740 starting at memory address XX. The LSB of the data to be stored at address XX can be written immediately after the MSb of address has been entered. Because the address is automatically incremented after the MSb of each byte is written, the LSB to be stored at address XX + 1 can be written immediately after the MSb to be stored at address XX. If the bus master continues to write beyond address FFh, the DS2740 starts over writing at address 00h. Writes to read-only addresses and reserved addresses are ignored. Incomplete bytes are not written. See the *Memory* section for more details.

iButton is a registered trademark of Dallas Semiconductor.

Figure 10. NET ADDRESS COMMAND FLOW CHART

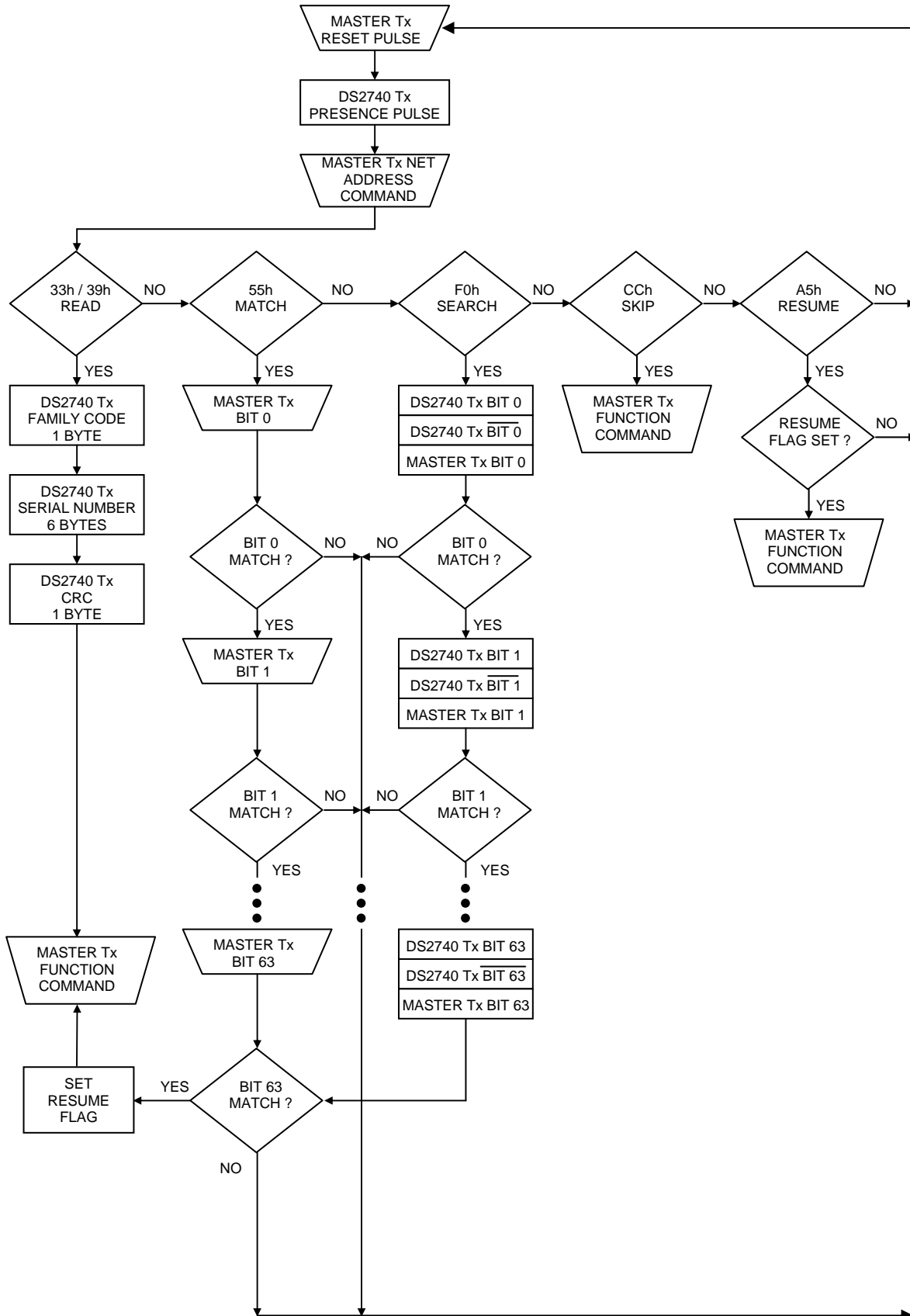

Table 4. FUNCTION COMMANDS

COMMAND	DESCRIPTION	COMMAND PROTOCOL	BUS STATE AFTER COMMAND PROTOCOL	BUS DATA
Read Data	Reads data from memory starting at address XX	69h, XX	Master Rx	Up to 256 bytes of data
Write Data	Writes data to memory starting at address XX	6Ch, XX	Master Tx	Up to 256 bytes of data

1-Wire SIGNALING

The 1-Wire bus requires strict signaling protocols to ensure data integrity. The four protocols used by the DS2740 are as follows: the initialization sequence (reset pulse followed by presence pulse), write 0, write 1, and read data. All of these types of signaling except the presence pulse are initiated by the bus master.

The initialization sequence required to begin any communication with the DS2740 is shown in Figure 11. A presence pulse following a reset pulse indicates that the DS2740 is ready to accept a net address command. The bus master transmits (Tx) a reset pulse for t_{RSTL} . The bus master then releases the line and goes into Receive mode (Rx). The 1-Wire bus line is then pulled high by the pullup resistor. After detecting the rising edge on the DQ pin, the DS2740 waits for t_{PDH} and then transmits the presence pulse for t_{PDL} .

Figure 11. 1-Wire INITIALIZATION SEQUENCE

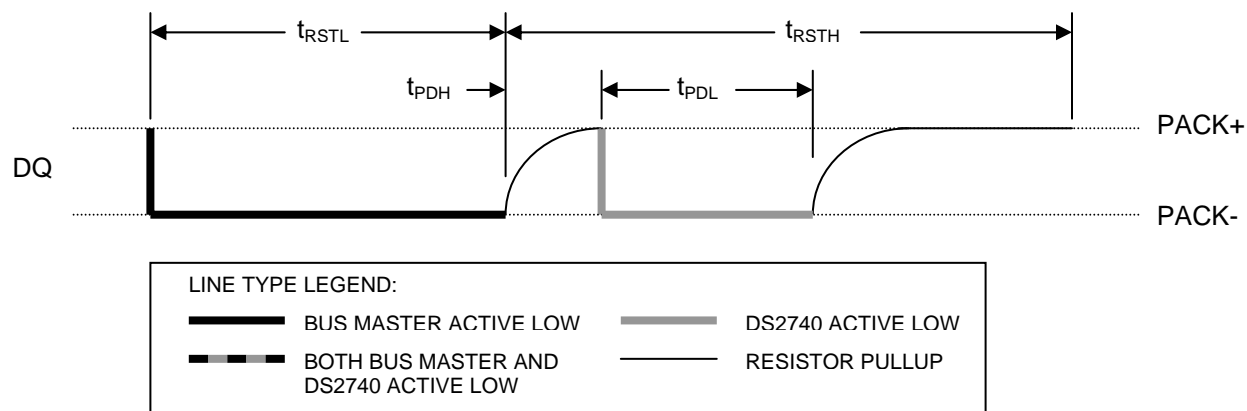

WRITE-TIME SLOTS

A write-time slot is initiated when the bus master pulls the 1-Wire bus from a logic-high (inactive) level to a logic-low level. There are two types of write-time slots: write 1 and write 0. All write-time slots must be t_{SLOT} in duration with a $1\mu s$ minimum recovery time, t_{REC} , between cycles. The DS2740 samples the 1-Wire bus line between $15\mu s$ and $60\mu s$ (between $2\mu s$ and $6\mu s$ for overdrive speed) after the line falls. If the line is high when sampled, a write 1 occurs. If the line is low when sampled, a write 0 occurs (see Figure 12). For the bus master to generate a write 1 time slot, the bus line must be pulled low and then released, allowing the line to be pulled high within $15\mu s$ ($2\mu s$ for overdrive speed) after the start of the write-time slot. For the host to generate a write 0 time slot, the bus line must be pulled low and held low for the duration of the write-time slot.

READ-TIME SLOTS

A read-time slot is initiated when the bus master pulls the 1-Wire bus line from a logic-high level to a logic-low level. The bus master must keep the bus line low for at least $1\mu\text{s}$ and then release it to allow the DS2740 to present valid data. The bus master can then sample the data t_{RDV} from the start of the read-time slot. By the end of the read-time slot, the DS2740 releases the bus line and allows it to be pulled high by the external pullup resistor. All read-time slots must be t_{SLOT} in duration with a $1\mu\text{s}$ minimum recovery time, t_{REC} , between cycles. See Figure 12 for more information.

Figure 12. 1-Wire WRITE- AND READ-TIME SLOTS

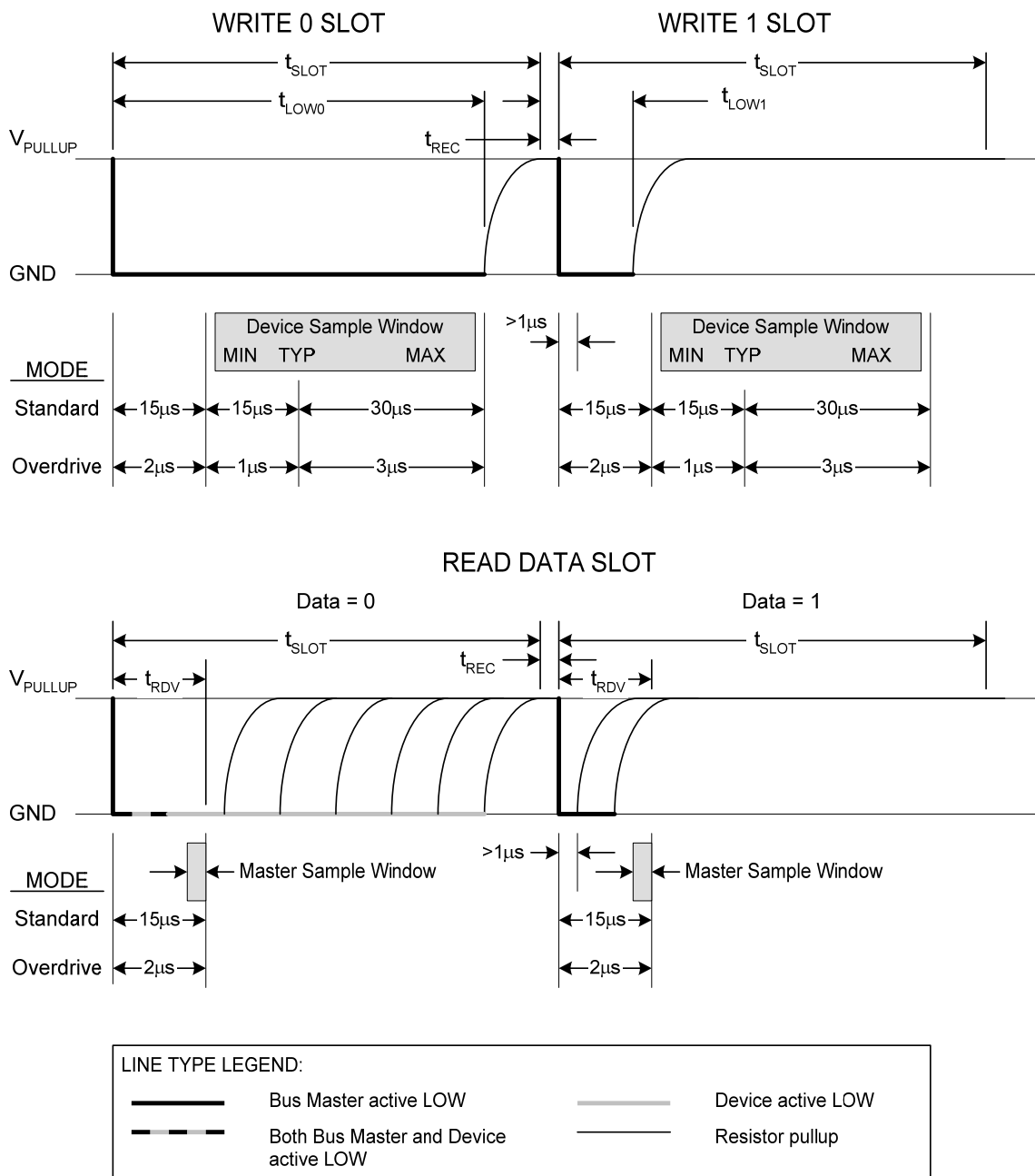

ABSOLUTE MAXIMUM RATINGS*

Voltage on V _{DD} , DQ, IS1, IS2, PIO, Relative to V _{SS}	-0.3V to +6V
Voltage on SNS, Relative to V _{SS}	-0.3V to +6V
Operating Temperature Range	-40°C to +85°C
Storage Temperature Range	-55°C to +125°C
Soldering Temperature	See IPC/JEDECJ-STD-020A

* This is a stress rating only and functional operation of the device at these or any other conditions above those indicated in the operation sections of this specification is not implied. Exposure to absolute maximum rating conditions for extended periods of time may affect reliability.

RECOMMENDED DC OPERATING CONDITIONS

(2.7V ≤ V_{DD} ≤ 5.5V; T_A = 0°C to +70°C.)

PARAMETER	SYMBOL	CONDITIONS	MIN	TYP	MAX	UNITS
Supply Voltage	V _{DD}	(Note 1)	2.7		5.5	V
Data Pin	DQ	(Note 1)	-0.3		+5.5	V

DC ELECTRICAL CHARACTERISTICS

(2.7V ≤ V_{DD} ≤ 4.2V; T_A = 0°C to +70°C.)

PARAMETER	SYMBOL	CONDITIONS	MIN	TYP	MAX	UNITS
Active Current	I _{ACTIVE}			50	65	μA
		V _{DD} = 5.5V			85	
Sleep-Mode Current	I _{SLEEP}	V _{DD} = 2.0V, DQ = PIO = V _{SS}		0.6	1.0	μA
		V _{DD} = 4.2V, DQ = PIO = V _{SS}		0.9	1.25	
Undervoltage Sleep Threshold	V _{UV}		2.3	2.5	2.7	V
Current Resolution	I _{LSB}	DS2740U		1.5625		μV/R _{SNS}
		DS2740BU		6.25		
Current Full-Scale Magnitude	I _{FS}			51.2		mV/R _{SNS}
Current Measurement Offset (Auto Calibrated)	I _{OERR}	DS2740U (Note 2)	-3	+1	+5	LSb
		DS2740BU (Note 2)	-2	0	+2	
Current Gain Error	I _{GERR}		-1		+1	% of reading
Accumulated Current Resolution	q _{CA}			6.25		μVh
Current Sample Clock Frequency	f _{SAMP}			18.6		kHz
Timebase Accuracy	t _{ERR}	V _{DD} = 3.5V at +25°C	-1		+1	%
			-4		+4	
Input Logic High: OVD	V _{IH}	(Note 1)	V _{DD} - 0.2V			V
Input Logic High: DQ, PIO	V _{IH}	(Note 1)	1.5			V
Input Logic Low: OVD	V _{IL}	(Note 1)			V _{SS} + 0.2	V

Input Logic Low: DQ, PIO	V_{IL}	(Note 1)	0.6	V
Output Logic Low: DQ, PIO	V_{OL}	$I_{OL} = 4\text{mA}$ (Note 1)	0.4	V
DQ, PIO Input Pulldown Current	I_{PD}	$V_{DD} = 4.2\text{V}$, $V_{DQ} = 0.4\text{V}$	0.5	μA
OVD Input Leakage	I_{LOVD}	PIO bit = 1	-1	1
DQ Capacitance	C_{DQ}		50	pF
DQ Low to Sleep Time	t_{SLEEP}	(Note 3)	2.0	2.4

ELECTRICAL CHARACTERISTICS: 1-Wire INTERFACE—STANDARD SPEED ($2.7\text{V} \leq V_{DD} \leq 5.5\text{V}$; $T_A = -20^\circ\text{C}$ to $+70^\circ\text{C}$.)

PARAMETER	SYMBOL	MIN	TYP	MAX	UNITS
Time Slot	t_{SLOT}	60		120	μs
Recovery Time	t_{REC}	1			μs
Write 0 Low Time	t_{LOW0}	60		120	μs
Write 1 Low Time	t_{LOW1}	1		15	μs
Read Data Valid	t_{RDV}			15	μs
Reset Time High	t_{RSTH}	480			μs
Reset Time Low	t_{RSTL}	480		960	μs
Presence Detect High	t_{PDH}	15		60	μs
Presence Detect Low	t_{PDL}	60		240	μs

ELECTRICAL CHARACTERISTICS: 1-Wire INTERFACE—OVERDRIVE SPEED

($2.7\text{V} \leq V_{DD} \leq 5.5\text{V}$; $T_A = -20^\circ\text{C}$ to $+70^\circ\text{C}$.)

PARAMETER	SYMBOL	MIN	TYP	MAX	UNITS
Time Slot	t_{SLOT}	6		16	μs
Recovery Time	t_{REC}	1			μs
Write 0 Low Time	t_{LOW0}	6		16	μs
Write 1 Low Time	t_{LOW1}	1		2	μs
Read Data Valid	t_{RDV}			2	μs
Reset Time High	t_{RSTH}	48			μs
Reset Time Low	t_{RSTL}	48		80	μs
Presence Detect High	t_{PDH}	2		6	μs
Presence Detect Low	t_{PDL}	8		24	μs

Note 1: All voltages are referenced to V_{SS} .

Note 2: Offset performance requires proper circuit layout design free of surface contaminants.

Note 3: The DS2740 enters the Sleep mode 2.0s to 2.4s after DQ goes low.

Looking for pricing, stock, or lifecycle information?

Click below to explore more details on WIN SOURCE:

 [View DS2740BU+](#) on WIN SOURCE

 [Maxim Integrated](#) Information

Optimize Your Supply Chain with WIN SOURCE Solutions

-  Global Sourcing Solution
-  Obsolete Management
-  Cost Control Management
-  Shortage Management
-  Alternative Solution
-  Excess Inventory Management