



**THE DATASHEET OF
DS2711E+**





DS2711/DS2712 Loose-Cell NiMH Chargers

GENERAL DESCRIPTION

The DS2711 and DS2712 are ideal for in-system or stand-alone charging of 1 or 2 AA or AAA NiMH “loose” cells. Temperature, voltage, and charge time are monitored to provide proper fast-charging control algorithms for nickel metal hydride (NiMH) batteries. Battery tests are included to detect defective or inappropriate cells such as alkaline primary batteries. The DS2711/DS2712 support series and parallel topologies, with independent monitoring and control of each cell. Charging of NiCd chemistry cells is also supported.

APPLICATIONS

- Desktop/Stand-Alone Chargers (AAA/AA)
- Digital Still Cameras
- Music Players
- Games
- Toys

FEATURES

- Charge 1 or 2 NiMH Cells
- Detect and Avoid Charging Alkaline Cells
- Precharge Deeply Depleted Cells
- Fast Charge NiMH with $-\Delta V$ Termination Sensitivity of 2mV (typ)
- Monitor Voltage, Temperature, and Time for Safety and Secondary Termination
- Regulate Charge Current:
 - Linear Control (DS2711)
 - Switch-Mode Control (DS2712)
- Drive pMOS or pnp-Type Pass Element or Switch, or an Optocoupler
- Compatible with Popular Optocouplers and Integrated Primary-Side PWM Controllers
- Small 16-Pin SO or TSSOP Packages

PIN CONFIGURATION

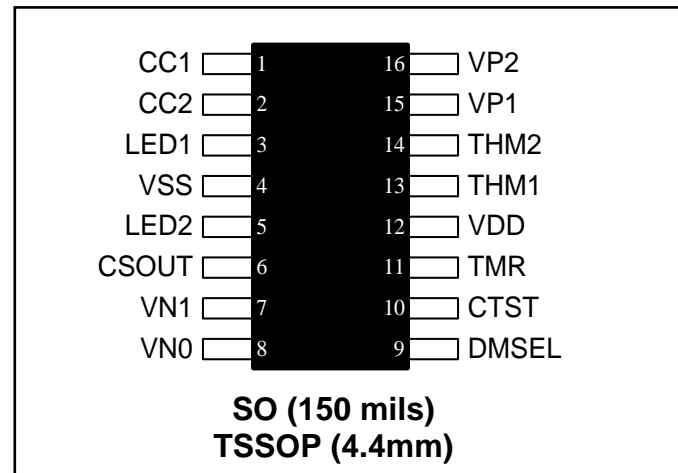

PIN DESCRIPTION

PIN	NAME	FUNCTION
1	CC1	Cell 1 Charge-Control Output
2	CC2	Cell 2 Charge-Control Output
3	LED1	Cell 1 Status
4	V _{SS}	Ground Reference and Chip-Supply Return
5	LED2	Cell 2 Status, Mode-Select Input
6	CSOUT	Current-Sense Output
7	VN1	Current-Sense + Input
8	VN0	Current-Sense - Input
9	DMSEL	Display-Mode Select
10	CTST	Cell Test Threshold Set
11	TMR	Charge Timer Set
12	V _{DD}	Chip-Supply Input (4.0V to 5.5V)
13	THM1	Cell 1 Thermistor Input
14	THM2	Cell 2 Thermistor Input
15	VP1	Cell 1 Positive-Terminal Sense Input
16	VP2	Cell 2 Positive-Terminal Sense Input

ABSOLUTE MAXIMUM RATINGS

Voltage Range on All Pins Relative to V_{SS}	-0.3V to +6V
Voltage Range on DMSEL.....	$V_{DD} + 0.3V$
Continuous Sink Current CC1, CC2, LED1, LED2, and CSOUT.....	20mA
Operating Temperature Range.....	-40°C to +85°C
Storage Temperature Range.....	-55°C to +125°C
Lead Temperature (soldering, 10s)	+300°C
Soldering Temperature (reflow)	
Lead(Pb)-free	+260°C
Containing lead(Pb).....	+240°C

This is a stress rating only and functional operation of the device at these or any other conditions above those indicated in the operation sections of this specification is not implied. Exposure to absolute maximum rating conditions for extended periods of time may affect reliability.

RECOMMENDED DC OPERATING CONDITIONS

($4.0V \leq V_{DD} \leq 5.5V$, $T_A = -20^\circ C$ to $+70^\circ C$, unless otherwise noted.)

PARAMETER	SYMBOL	CONDITIONS	MIN	TYP	MAX	UNITS
Supply Voltage	V_{DD}	(Note 1)	4.0		5.5	V
Input Voltage Range		LED2, DMSEL	-0.3		+5.5	V

DC ELECTRICAL CHARACTERISTICS

($4.0V \leq V_{DD} \leq 5.5V$, $T_A = -20^\circ C$ to $+70^\circ C$, unless otherwise noted.)

PARAMETER	SYMBOL	CONDITIONS	MIN	TYP	MAX	UNITS
Supply Current, V_{DD}	I_{DD}	Operating mode		250	500	μA
UVLO Threshold	V_{UVLO}	V_{DD} rising (Note 1)		3.5	3.9	V
UVLO Hysteresis	V_{UHYS}	V_{DD} falling from above V_{UVLO}	40			mV
Output-Voltage Low, CC1, CC2, LED1, LED2	V_{OL1}	$V_{DD} = 5.0V$, $I_{OL} = 20mA$ (Note 1)			1.0	V
Output-Voltage Low, CSOUT	V_{OL2}	$V_{DD} = 5.0V$, $I_{OL} = 20mA$ (Note 1)		0.75	1.25	V
Leakage Current, CC1, CC2, LED1, LED2, CSOUT	I_{LKG}	$V_{DD} = 5.0V$, Output inactive	-1		+1	μA
Threshold Voltage, $-\Delta V$ Termination	$V_{-\Delta V}$	After t_{THO}	1.0	2.0	3.0	mV
Mode Test Current, DMSEL, LED2	I_{MTST}	(Notes 2, 3)		5	15	μA
Input Logic-High, DMSEL, LED2	V_{IH}	(Note 1)	$V_{DD} - 0.2$			V
Input Logic-Low, DMSEL, LED2	V_{IL}	(Note 1)			0.2	V
Input Leakage Current, DMSEL	I_{IL1}	After power-up mode select, DMSEL = V_{DD} or V_{SS}	-1		+1	μA
Threshold Voltage, Cell Test	V_{CTST}	$R_{CTST} = 80k\Omega$	85	100	115	mV
Threshold Voltage, Cell Voltage Low	$V_{BAT-LOW}$	CC1 = CC2 = high-Z (Note 4)	0.9	1.0	1.1	V
Threshold Voltage, Cell Voltage Max1	$V_{BAT-MAX1}$	CC1 = CC2 = high-Z (Note 4)	1.55	1.65	1.75	V
Threshold Voltage, Cell Voltage Max2	$V_{BAT-MAX2}$	CC1, CC2 active (Note 4)	1.64	1.75	1.86	V
Threshold Voltage Delta	$V_{BAT-MAX\Delta}$	$V_{BAT-MAX2} - V_{BAT-MAX1}$ (Note 5)	90	100	110	mV

PARAMETER	SYMBOL	CONDITIONS	MIN	TYP	MAX	UNITS
Threshold Voltage, Thermistor - Min	$V_{THM-MIN}$	(Notes 1, 4, 6)		$V_{DD} \times 0.73$		V
Threshold Voltage, Thermistor - Max	$V_{THM-MAX}$	(Notes 1, 4, 6)	0.30	$V_{DD} \times 0.33$	0.36	V
Threshold Voltage, Thermistor - Stop	$V_{THM-STOP}$	(Notes 1, 4, 6)		$V_{DD} \times 0.29$		V
Threshold Current, TMR Pin Suspend	$I_{TMR-SUS}$			0.1	0.5	μA
Presence Test Current, VP1, VP2	I_{PTST}	Parallel: $V_{DD} \geq 4.0V$, Series: $V_{DD} \geq 4.5V$		10	15	μA
Reverse Leakage Current, VP1, VP2	I_{LKGR}	$V_{DD} = 0V$, $VP1 = 1.5V$, $VP2 = 3.0V$			2	μA
Current-Sense Reference Voltage	V_{IREF}	(Note 1, 4, 7)	125			mV
			-6%		+6%	%
Gain, Current-Sense Error Amp	G_M	DS2711 (Note 8)	0.9		1.5	Ω^{-1}
Gain, Current-Sense Comparator	G_M	DS2712 (Note 8)	10			Ω^{-1}
Propagation Time, Current-Sense Comparator	t_{PDLY}	DS2712, 2mV over/underdrive			0.25	μs
Hysteresis, Current-Sense Comparator	$V_{HYS-COMP}$	DS2712	22	24	26	mV

ELECTRICAL CHARACTERISTICS: TIMING

($4.0V \leq V_{DD} \leq 5.5V$, $T_A = -20^\circ C$ to $+70^\circ C$, unless otherwise noted.)

PARAMETER	SYMBOL	CONDITIONS	MIN	TYP	MAX	UNITS
Internal Timebase Period	t_{BASE}			0.96		s
Internal Timebase Accuracy			-10		+10	%
Duty Factor, Series Fast Charge		CC1		0.969		
Duty Factor, Series Precharge/Top-Off		CC1		0.250		
Duty Factor, Parallel Fast Charge		CC1, CC2		0.484		
Duty Factor, Parallel Precharge/Top-Off		CC1, CC2		0.125		
Duty Factor, Maintenance Charge		CC1, CC2		0.0156		
Cell Test Interval	t_{CTST}			31		Seconds
Precharge Timeout	t_{PCHG}	$V_{CELL} < V_{BAT-MIN}$		34		Minutes
Fast-Charge Termination Hold-Off Period	t_{THO}			4		Minutes
Fast-Charge Flat Voltage Timeout	t_{FLAT}	V_{CELL} not increasing		16		Minutes
Charge Timer Period	t_{CTMR}	$R_{TMR} = 100k\Omega$		2.5		Hours

PARAMETER	SYMBOL	CONDITIONS	MIN	TYP	MAX	UNITS
Charge Timer Accuracy		$R_{TMR} = 100k\Omega$	-5		+5	%
Charge Timer Range	$t_{CTMR-RANGE}$		0.5		10	Hours

ELECTRICAL CHARACTERISTICS: TIMING (continued)

($4.0V \leq V_{DD} \leq 5.5V$, $T_A = -20^\circ C$ to $+70^\circ C$, unless otherwise noted.)

- Note 1:** Voltages relative to V_{SS} .
- Note 2:** I_{MTST} current is applied as a source current and as a sink current within 5ms after power-up.
- Note 3:** When operating in two-cell-series charge configuration, the DMSEL pin must have less than 50pF of external load capacitance for proper operation. If the load capacitance is greater than 50pF, a resistor voltage-divider should be used to maintain DMSEL at $V_{DD}/2$.
- Note 4:** Specification applicable during charge cycle with $T_A = 0^\circ C$ to $+70^\circ C$.
- Note 5:** $V_{BAT-MAX1}$ and $V_{BAT-MAX2}$ are generated from the same reference. Their ranges never overlap.
- Note 6:** $V_{THM-MIN}$, $V_{THM-MAX}$, and $V_{THM-STOP}$ are fixed ratios of V_{DD} . Their ranges never overlap.
- Note 7:** Tested with $I_{CSOUT} = -1mA$.
- Note 8:** Gain tested with 1mV step with $I_{CSOUT} = -1mA$.

Figure 1. Block Diagram

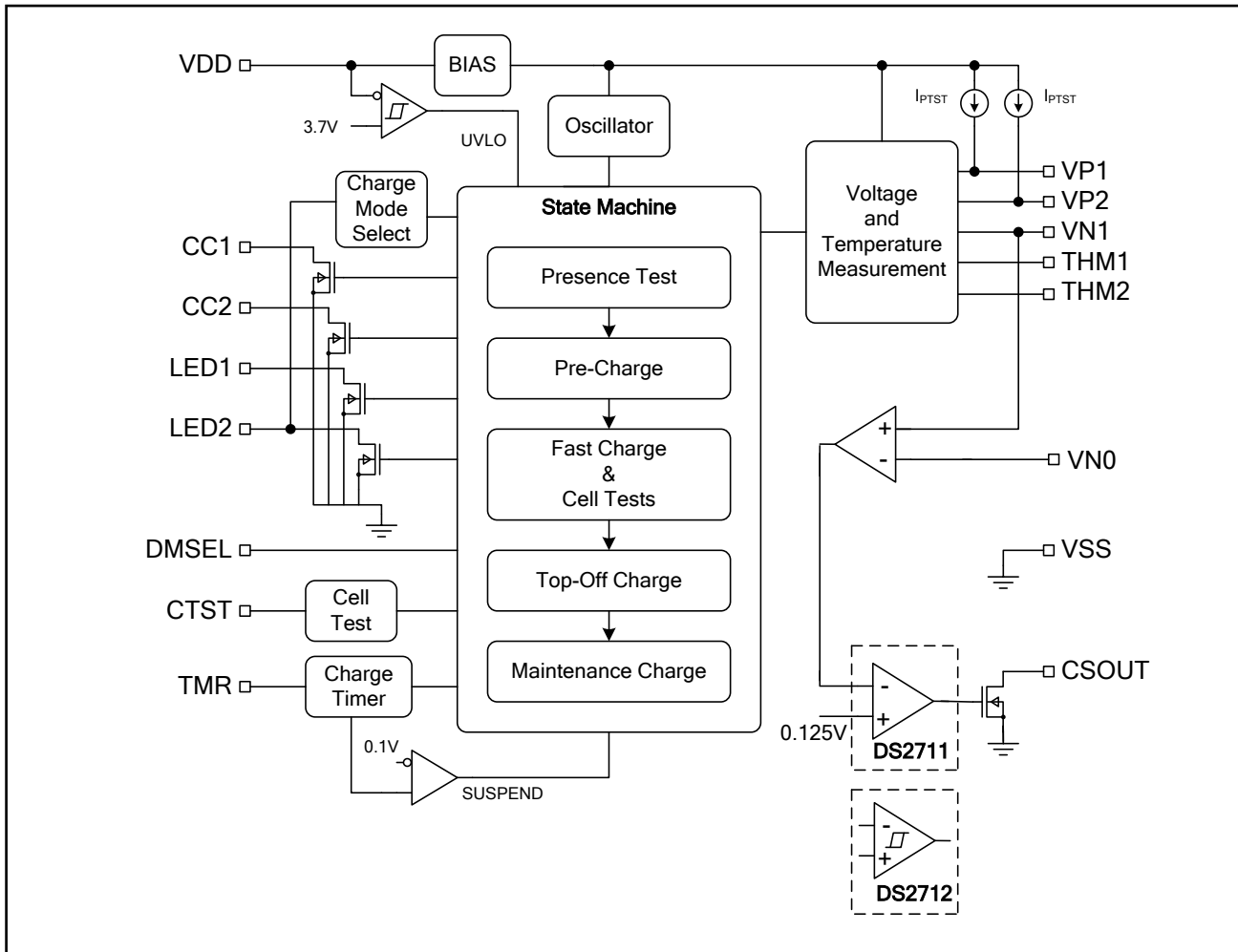
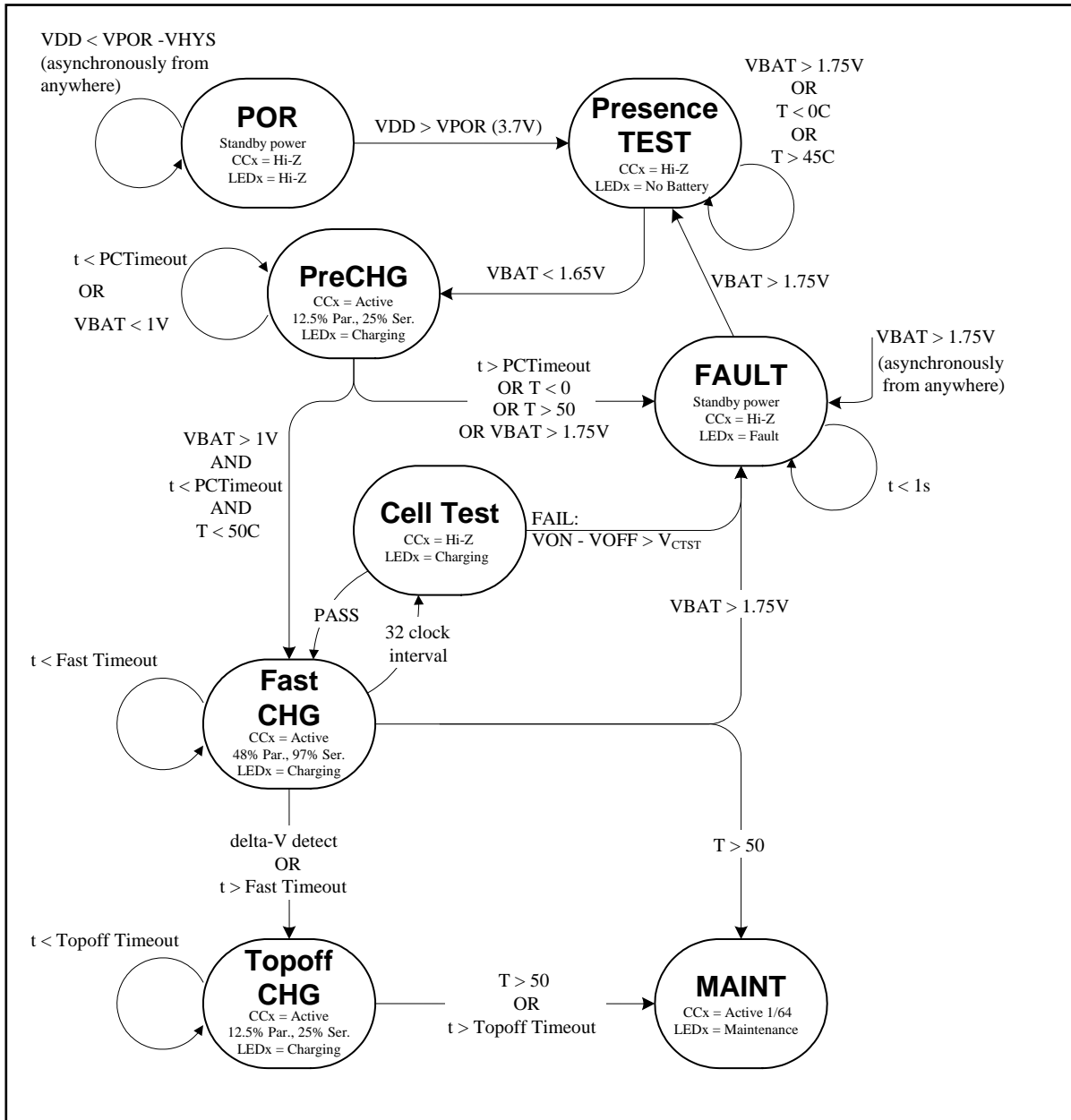

Figure 2. State Diagram



DETAILED DESCRIPTION

Charge Algorithm Overview

A charge cycle begins in one of three ways: with the application of power to the DS2711 with cell(s) already inserted, with the detection of cell insertion after power-up, or when exiting suspend mode with cell(s) inserted. The charge cycle begins with precharge qualification to prevent fast charging of deeply depleted cells or charging under extreme temperature conditions. Precharging is performed at a reduced rate until each cell reaches 1V. The algorithm proceeds to a fast-charge phase, which includes cell tests to avoid accidental charging of alkaline cells or NiMH cells that are worn-out or damaged. Fast charging continues as long as the cell temperature(s) are less than 50°C (based on THM1, THM2 voltages) and the open-circuit cell voltage(s) are between 1.0V and 1.75V. Fast charging terminates by the $-\Delta V$ (negative delta voltage) method. The top-off charge phase follows to completely charge the cells. After the top-off charge timer expires, the maintenance charge phase continues indefinitely to keep the cells at a full state of charge. Maximum voltage, temperature, and charge-time monitoring during all charge phases act as secondary or safety termination methods to provide additional protection from overcharge. Each cell is monitored independently, and in parallel mode the charge phase of each cell is independently controlled.

Series Charge Configuration

The DS2711/DS2712 series configuration supports one or two-slot stand-alone and one or two cell in-system chargers. The single-cell-series mode charges one cell while the two-cell-series mode charges two series cells. Since the cells are charged in series, cell sizes should not be mixed in the series configuration. In the application example in Figure 3, charge current is gated to the battery cells by a PNP transistor under the control of the CC1 pin of the DS2711. Current regulation is performed outside of this example schematic using the current-sense feedback provided by the DS2711 CSOUT pin. The DS2712 can also be used in this circuit to provide switch-mode control on the CSOUT pin. $RSNS = 0.125\Omega$ sets the charge source current, ICHG, to 1A. In series mode, the effective charge current is $0.969 \times ICHG = 969\text{mA}$.

Figure 3. Series Configuration with External Current Regulation

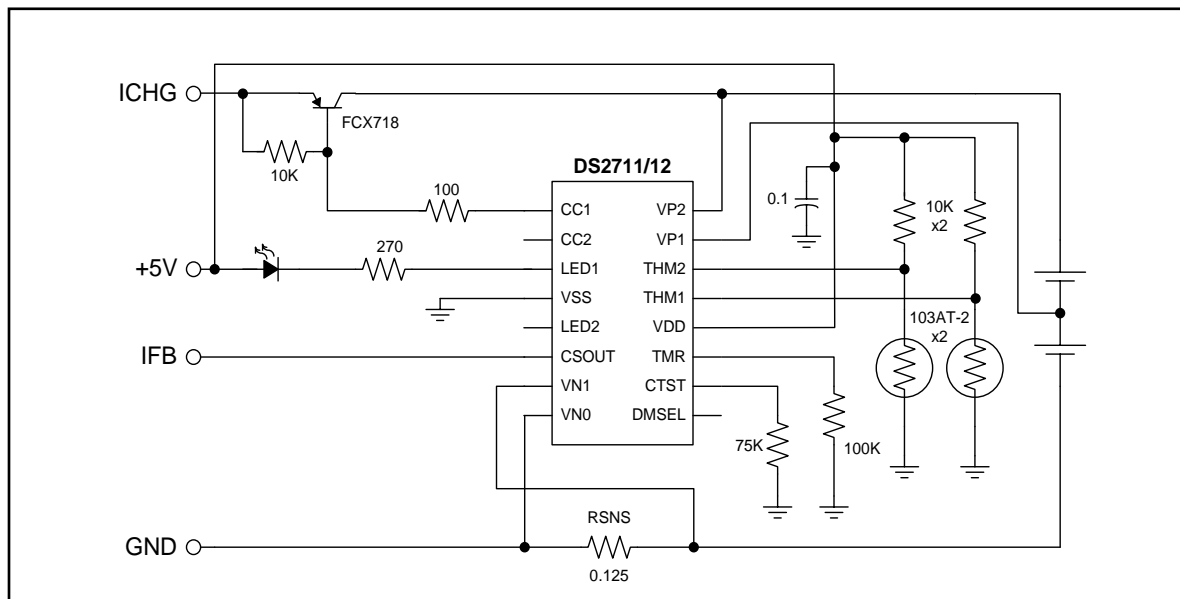

Parallel Charge Configuration

The parallel configuration supports two slot stand-alone chargers. Charge pulses are fed alternately to each cell under the control of the CC1 and CC2 pins so the charge regimes occur in parallel. The duty cycle on CC1 and CC2 are independent of one another. Transitions from precharge to fast charge, fast charge to top-off, and top-off to maintenance occur independently for each cell.

The configuration shown in Figure 4 is for charging two cells with the current-sense feedback regulating the charge source to 2A ($R_{SNS} = 0.068\Omega$). The effective charge current for each cell is $2A \times 0.484 = 0.968A$. A charger with battery holders designed to accept either AA or AAA cell sizes can be constructed with the current-sense resistance split between two separate resistors so each cell type (AA or AAA) is charged at a different rate. Mechanical design of the holders is required to prevent insertion of more than one cell in each slot. The holder design must also prevent electrical contact with reverse polarity insertion.

Figure 4. Parallel Configuration with External Current Regulation

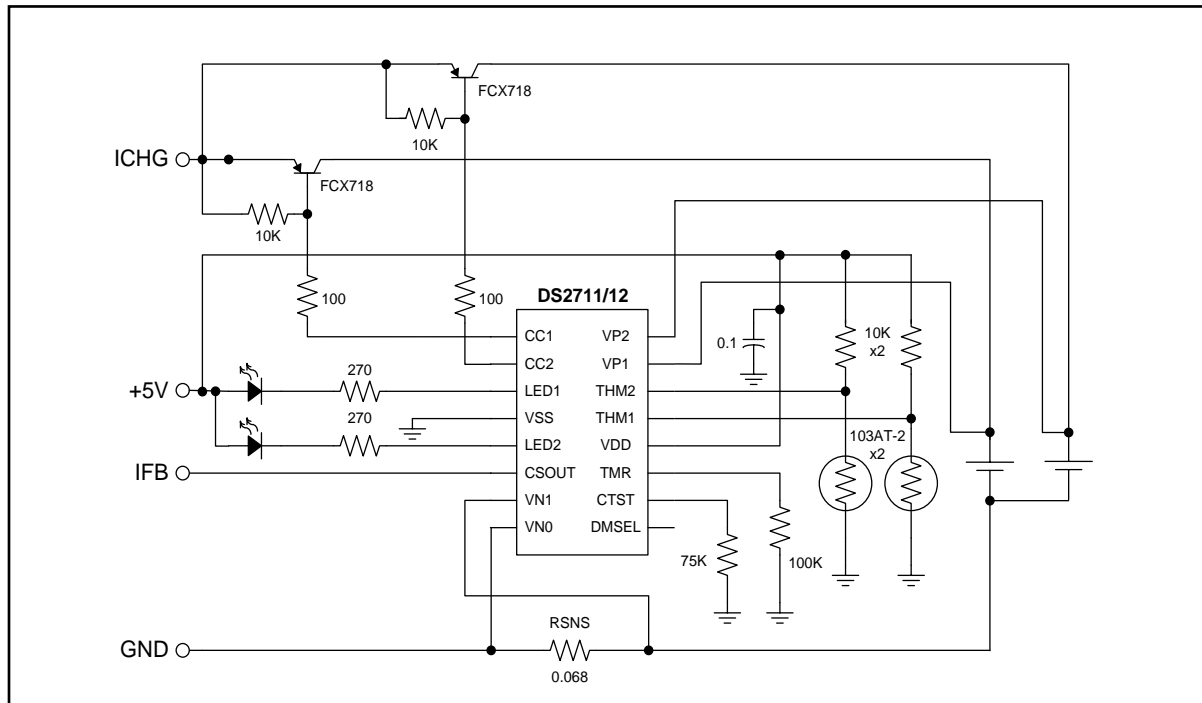

The series or parallel charge configuration is programmed by strapping LED2 in the low, high, or high-Z state during power-up. In this example and the following one, the parallel charge mode is selected by pulling LED2 pin high during power-up. This is accomplished in this example by the LED and 270Ω resistor. In applications where only one LED is used, a 100kΩ pullup resistor is recommended. See Table 2 for additional configuration programming information.

Undervoltage Lockout (UVLO)

The UVLO circuit serves as a power-up and brownout detector by monitoring V_{DD} to prevent charging until V_{DD} rises above V_{UVLO} , or when V_{DD} drops below $V_{UVLO} - V_{HYS}$. If UVLO is active, charging is prevented, the state machine is forced to the RESET state, and all charge timers are reset. A 10 μ s deglitch circuit provides noise immunity.

Internal Oscillator and Clock Generation

An internal oscillator provides the main clock source used to generate timing signals for internal chip operation. The precharge timer, hold-off timers, and timings for CC1/CC2 operation and cell testing are derived from this timebase.

Current-Sense Amplifier (DS2711)

An error amplifier block provides several options to regulate the charge current. The 20mA open-drain output can drive a PMOS or PNP pass element for linear regulation, or the output can drive an optocoupler for isolated feedback to a primary-side PWM controller. The VN0 pin is a remote-sense return and should be connected to the grounded side of the sense resistor using a separate, insulated conductor.

Figure 6. Current-Sense Amplifier Response

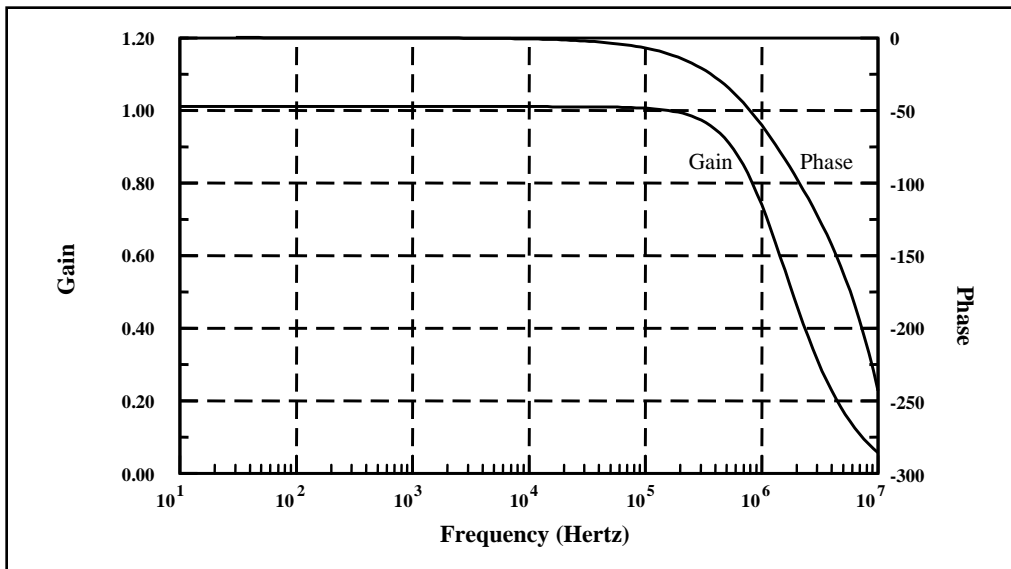

The open-loop amplifier response shown in Figure 6 was measured with $I_{CSOUT} = -1\text{mA}$. An error signal between the current-sense signal (across a sense resistor) and the 0.125V internal reference is produced so the voltage across the sense resistor is maintained at V_{IREF} in a closed-loop circuit.

Current-Sense Comparator (DS2712)

The comparator in the DS2712 switches between ON and OFF and is capable of driving a PNP bipolar or a PMOS transistor, enabling the use of a switched-mode power stage. Hysteresis on the comparator input provides noise rejection. In the closed-loop regulation circuit of Figure 5, the comparator regulates voltage across the sense resistor to a DC average of:

$$V_{RSNS} = V_{IREF} - 0.5 \times V_{HYS-COMP} = 0.125\text{V}$$

Charge Timer

The charge timer monitors the duration of charge in fast and top-off charge phases, and is reset at the beginning of each phase. The timeout period is set with an external resistor connected from the TMR pin to V_{SS} . Resistors can be selected to support fast-charge timeout periods of 0.5 to 10 hours and top-off charge timeout periods of 0.25 to 5 hours. If the timer expires in fast-charge, the timer count is reset and charging proceeds to the top-off charge phase. The top-off timeout period is half of the fast charge timeout period. If the timer expires in top-off, charging proceeds to the maintenance phase. The programmed charge time approximately follows the equation:

$$t = 1.5 \times R/1000 \text{ (time in minutes)}$$

Suspend

Suspension of charge activity is possible by disconnecting the TMR pin. The CC1 and CC2 outputs become high-Z and the charge timer stops. The state machine and all timers are reset to their presence test conditions.

Temperature Sense

Connecting an external 10k Ω NTC thermistor between THM1 or THM2 (THMx) and V_{SS} , and a 10k Ω bias resistor between V_{DD} and THMx allows the DS2711 to sense temperature. To sense the temperature of the battery cells, locate the thermistor close to the body of the battery cell so THM1 monitors the temperature of cell-1 and THM2 monitors the temperature of cell-2. Alternatively, the thermistor can sense ambient temperature by locating it away from the cells. THM1 and THM2 can be connected together to sense temperature using a single thermistor and bias resistor. The temperature qualification function can be defeated by connecting THM1 and THM2 to a single resistor-divider supplying a voltage between the Thermistor-Min and Thermistor-Max threshold voltages. Several recommended 10k Ω thermistors are shown in Table 2.

Min, Max Temperature Compare

The voltage thresholds of the THMx inputs (VTHM-MIN, VTHM-MAX) are set to allow fast charging to start if $0^\circ\text{C} < T_A < 45^\circ\text{C}$ when using the recommended 10k Ω bias and 10k Ω thermistor. If fast charging is in progress, and the voltage on THMx reaches VTHM-STOP, fast charging stops and the maintenance phase begins.

Table 1. THM1, THM2 Thresholds

THM THRESHOLD	RATIO OF V_{DD}	THERMISTOR RESISTANCE (Ω)	TEMPERATURE ($^\circ\text{C}$)	
			Semitec 103AT-2	Fenwal 197-103LAG-A01 173-103LAF-301
MIN	0.73	27.04k	0	4
MAX	0.33	4.925k	45	42
STOP	0.29	4.085k	50	47

Figure 7. Cell Voltage Sense Points

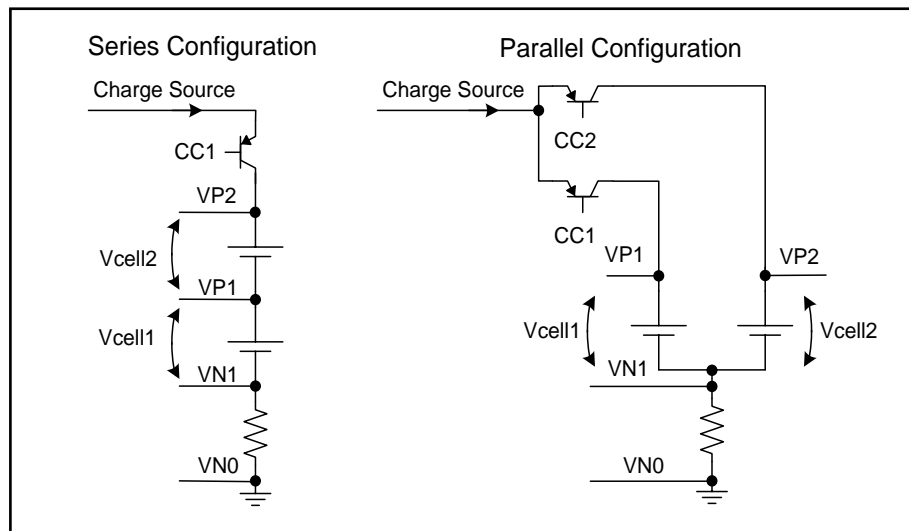

Cell Voltage Monitoring

In the 2-cell series mode, the voltage difference between VP2 and VP1 is used to determine the V_{cell2} voltage in the two-cell series stack. The voltage difference between VP1 and VN1 is used to determine the V_{cell1} voltage. In the 1-cell series mode, the difference between VP1 and VN1 is used as the cell voltage. VP2 can be left disconnected in the 1-cell series mode. In parallel mode, the difference between VP2 and VN1 is used for the V_{cell2} voltage, and the difference between VP1 and VN1 is used for V_{cell1} voltage.

Individual cell voltages are monitored for minimum and maximum values, using the V_{BAT-MIN}, V_{BAT-MAX1} and V_{BAT-MAX2} threshold limits. Upon inserting a cell or power-up with cells inserted, cell voltages must be less than the V_{BAT-MAX1} threshold before charging begins. The V_{BAT-MIN} threshold determines whether a precharge cycle should precede the fast charge cycle, and when to transition from precharge to fast charge. Once fast charging commences, cell voltages are compared to the V_{BAT-MAX2} threshold once per second. The comparison occurs while the charge control pin (CC1 or CC2) controlling current to the cell is active (low). When the charge control pin is active so charge is applied to the cell, the cell voltage is referred to as the V_{ON} voltage. When the charge-control pin is inactive, the cell voltage is referred to as the V_{OFF} voltage. If V_{BAT-MAX2} is exceeded in fast charge, charging is halted and a fault condition is displayed. While fast charge is in progress, cell voltage measurements are stored and compared to future measurements for charge termination and cell test purposes.

Two types of tests are performed to detect primary alkaline and lithium cells or defective NiMH or NiCd secondary cells. Cells are tested individually in the series and parallel configurations, so that a single improper or defective cell can be detected quickly. In the series configuration, a single defective cell will terminate charge for both cells, whereas the parallel mode continues charging the good cell and stops charging the defective cell.

V_{CTST} is set by the resistance from the CTST pin to ground. The nominal sensitivity of 100mV is set by connecting an 80kΩ resistor between CTST and V_{SS}. The detection threshold can be set from 32mV to 400mV. The following formula approximates the setting for the detection threshold.

$$V_{CTST} = 8000/R \text{ (value in } \Omega \text{)}$$

-ΔV and Flat Voltage Termination

During fast charge, -ΔV detection is performed by comparing successive voltage measurements for a drop of 2mV in the cell voltage. A hold-off period for -ΔV detection begins at the start of fast charging and prevents false termination in the first few minutes of the charge cycle. Once the hold-off period expires, cell voltage measurements are acquired every 32 clock cycles (during the CCx off time). When a newly acquired voltage measurement is greater than any previous one, the new value is retained as the maximum value. When the cell voltage no longer increases, the maximum value is retained and compared against subsequent values. If the cell voltage drops by the -ΔV threshold, V_{-ΔV}, (2mV typ), fast charging is terminated. If the cell voltage remains flat such that the maximum value persists for a period of 16 minutes (t_{FLAT}), fast charge terminates and top-off charging begins.

Top-Off and Maintenance

In top-off mode, the charger scales the cell current to 25% of the fast charge current. The charge timer is reset and restarted with a timeout period of one-half the fast-charge duration. When the charge timer expires in top-off, the charger enters maintenance and delivers 1/64 of the charge source current to the cells. Maintenance charge continuous until power is removed, the cell(s) are removed or the DS2711/DS2712 is cycled into and out of suspend mode by disconnecting the TMR pin.

Selecting the Charge Mode

The charge mode configuration is selected by testing the LED2 pin during startup. An internal current source tests the state of the LED2 pin by pulling up and pulling down on the pin to determine if it is high, low, or open. The recommended pullup or pulldown resistor value (if used) is 100kΩ. In the parallel charging circuit diagrams on page 7, no resistor is shown. The current path through the LED and 270Ω resistor is sufficient to pull the LED2 pin high at power-up to select the parallel mode. See to the mode test current (I_{MTST}) specification in the *DC Electrical Characteristics* table to select other pullup values.

Table 2. Charge Mode Selection

LED2 PIN STRAPPING	MODE
Low	1-Cell Series
Open	2-Cell Series
High	Parallel

CC1 and CC2 Outputs

The CC1 and CC2 operate as open-drain outputs that drive active low to connect the charge source to the battery cell. During charge, the behavior of the CC1 and CC2 outputs depends on the charge-mode configuration. In parallel mode, CC1 and CC2 are driven low in alternating time slots. The charge source is loaded by just one cell during any time slot. In the 1-cell and 2-cell series mode, only CC1 is driven. Except for the periodic performance of impedance and $-\Delta V$ tests, series mode charging is continuous during the fast charge phase rather than pulsed in parallel mode.

Parallel Mode Fast Charge

Referring to Figure 4, CC1 controls the PNP switch that gates current to the cell in slot 1. CC2 controls the PNP switch that gates current to the cell in slot 2. During fast charge, current is gated to each slot sequentially, with charge pulses occurring in alternating time frames. The cell in one slot charges while the other relaxes and the effective fast-charge current is 48.4% of the magnitude set by the charge-source current limit. The parallel configuration skips a charge pulse every 32 clock cycles to facilitate independent testing of the open- and closed-circuit cell voltages (V_{OFF} and V_{ON} , respectively). Since the charge regime of each cell is independent, one cell may complete a charge phase before the other. The more fully charged cell of a pair inserted at the same time could terminate fast charge by $-\Delta V$, then charge in top-off while the less charged cell continues in fast charge. In the case of an improper or faulty cell (e.g., alkaline) being inserted along with a proper cell (NiMH or NiCd), charging of the faulty cell would be stopped, while the proper cell is charged to full.

Series Mode Fast Charge

Referring to Figure 3, CC1 controls the PNP switch that gates current to the cell(s). In series mode, 1 or 2 cells can be charged, depending on whether the 1-cell or 2-cell series mode has been selected. During fast charge, current is gated to the cell(s) almost continuously, with the effective fast-charge current approximately equal to current limit of the charge source. The series configuration deactivates CC1 briefly every 32 clock cycles to facilitate independent testing of V_{OFF} and V_{ON} of each cell. The one second deactivation makes the duty factor 0.969 and therefore the effective current equals approximately 97% of the charge-source current limit. In the 2-cell series mode, the characteristics of each cell are evaluated individually; however charging stops if either cell is determined to be improper or faulty.

In the 1-cell charge series mode, CC1 gates the charge current as in the 2-cell series mode. The cell voltage is monitored between VP1 and VN1, and temperature is monitored with THM1. The VP2 and THM2 pins can be left disconnected in the 1-cell series mode.

EXAMPLE CAPACITIES AND CHARGE RATES**Parallel Charging Example**

A 1700mAh cell is charged using a 1A regulated charge source. During fast charge, the cell is charged at a duty factor of 0.484 and receives an effective charge current of 0.484A. In terms of C-rate, this is $484\text{mA}/1700\text{mAh} = 0.285^{\circ}\text{C}$ (or C/3.5). During precharge and top-off, the duty factor is 0.125 (i.e., 1/8), for an effective average current of 125mA, corresponding to a C-rate of $125/1700 = 0.073\text{C}$ (or C/13.6). Similarly, in maintenance mode, the duty factor is 0.0156 (i.e., 1/64) and the C-rate is $15.6/1700 = 0.0092$ (or C/109). The C-rates for charging 3 different cell capacities using a 500mA and a 1000mA current source are shown in Table 3.

Table 3. Parallel Configuration, Each Cell

MODE	CURRENT LIMIT 500mA			CURRENT LIMIT 1000mA		
	900mAH	1700mAH	2200mAH	900mAH	1700mAH	2200mAH
Cell Capacity	900mAH	1700mAH	2200mAH	900mAH	1700mAH	2200mAH
Fast	C/3.72	C/7.02	C/9.08	C/1.86	C/3.51	C/4.54
Precharge/Top-Off	C/14.4	C/27.2	C/35.2	C/7.20	C/13.6	C/17.6
Maintenance	C/115	C/218	C/282	C/57.6	C/109	C/141

Series and Single Cell Charging Example

In the series and single-cell modes, the effective fast charge current is equal to 0.969 times the regulated current limit and the top-off current is 0.25 times the regulated current. The maintenance mode is identical to the parallel charging rate, that is, 1/64 times the regulated current. The C-rates for charging 3 different cell capacities using a 500mA and a 1000mA current source are shown in Table 4.

Table 4. Series Configuration, Each Cell

MODE	CURRENT LIMIT 500mA			CURRENT LIMIT 1000mA		
	900mAH	1700mAH	2200mAH	900mAH	1700mAH	2200mAH
Cell Capacity	900mAH	1700mAH	2200mAH	900mAH	1700mAH	2200mAH
Fast	C/1.86	C/3.51	C/4.54	C/0.93	C/1.75	C/2.27
Precharge/Top-Off	C/7.20	C/13.6	C/17.6	C/3.60	C/6.80	C/8.80
Maintenance	C/115	C/218	C/282	C/57.6	C/109	C/141

LED1 and LED2 Outputs, MODE-Select Input

Open-drain outputs LED1 and LED2 pull low to indicate charge status. When inactive, the outputs are high impedance. LED1 displays the status for the cell monitored by VP1 and LED2 displays the status for the cell monitored by VP2.

The LED pins drive low in three “blink” patterns to announce the charge status. Table 5 summarizes the LED operation in each display mode (DM0, DM1, DM2) for each charge condition. In parallel mode, LED1 indicates the status of the cell whose positive terminal is connected to VP1 and LED2 indicates the status of the cell whose positive terminal is connected to VP2. In series mode, LED1 indicates the charge status for both cells since they are charged in series.

Table 5. Display Patterns by Display Mode and Charge Activity

DISPLAY MODE	DMSEL PIN	CHARGE ACTIVITY			
		NO BATTERY	PRE/FAST/ TOP-OFF CHARGING	MAINTENANCE	FAULT
DM0	Low	High Impedance	Low	0.80s Low 0.16s High Impedance	0.48s Low 0.48s High Impedance
DM1	Open	High Impedance	Low	High Impedance	0.16s Low 0.16s High Impedance
DM2	High	High Impedance	0.80s Low 0.16s High Impedance	Low	0.16s Low 0.16s High Impedance

ORDERING INFORMATION

PART	TEMP RANGE	PIN-PACKAGE	TOP MARK
DS2711Z	-40°C to +85°C	16 SO	DS2711
DS2711Z+	-40°C to +85°C	16 SO	DS2711
DS2711Z/T&R	-40°C to +85°C	16 SO	DS2711
DS2711Z+T&R	-40°C to +85°C	16 SO	DS2711
DS2711E+	-40°C to +85°C	16 TSSOP	DS2711
DS2711E+T&R	-40°C to +85°C	16 TSSOP	DS2711
DS2712Z	-40°C to +85°C	16 SO	DS2712
DS2712Z+	-40°C to +85°C	16 SO	DS2712
DS2712Z/T&R	-40°C to +85°C	16 SO	DS2712
DS2712Z+T&R	-40°C to +85°C	16 SO	DS2712
DS2712E+	-40°C to +85°C	16 TSSOP	DS2712
DS2712E+T&R	-40°C to +85°C	16 TSSOP	DS2712

+Denotes a lead(Pb)-free/RoHS-compliant package.

T&R = Tape and reel.

PACKAGE INFORMATION

For the latest package outline information and land patterns (footprints), go to www.maxim-ic.com/packages. Note that a "+", "#", or "-" in the package code indicates RoHS status only. Package drawings may show a different suffix character, but the drawing pertains to the package regardless of RoHS status.



PACKAGE TYPE	PACKAGE CODE	OUTLINE NO.	LAND PATTERN NO.
16 SO	S16+1	21-0041	90-0097
16 TSSOP	U16+1	21-0066	90-0117

REVISION HISTORY

REVISION DATE	DESCRIPTION	PAGES CHANGED
120808	Changed Figure 2 to include "T <0" as a condition to move from Pre-Charge to Fault state	6
4/11	Updated the lead and soldering temperature information in the <i>Absolute Maximum Ratings</i> section; updated Figure 1; updated the <i>Internal Oscillator and Clock Generation</i> section; added the Package Information table	3, 5, 10, 14

Looking for pricing, stock, or lifecycle information?

Click below to explore more details on WIN SOURCE:

-  [View DS2711E+ on WIN SOURCE](#)
-  [Maxim Integrated Information](#)

Optimize Your Supply Chain with WIN SOURCE Solutions

-  Global Sourcing Solution
-  Obsolete Management
-  Cost Control Management
-  Shortage Management
-  Alternative Solution
-  Excess Inventory Management