



THE DATASHEET OF P0496



DE10-Nano

Cyclone V SoC with Dual-core ARM Cortex-A9

User Manual

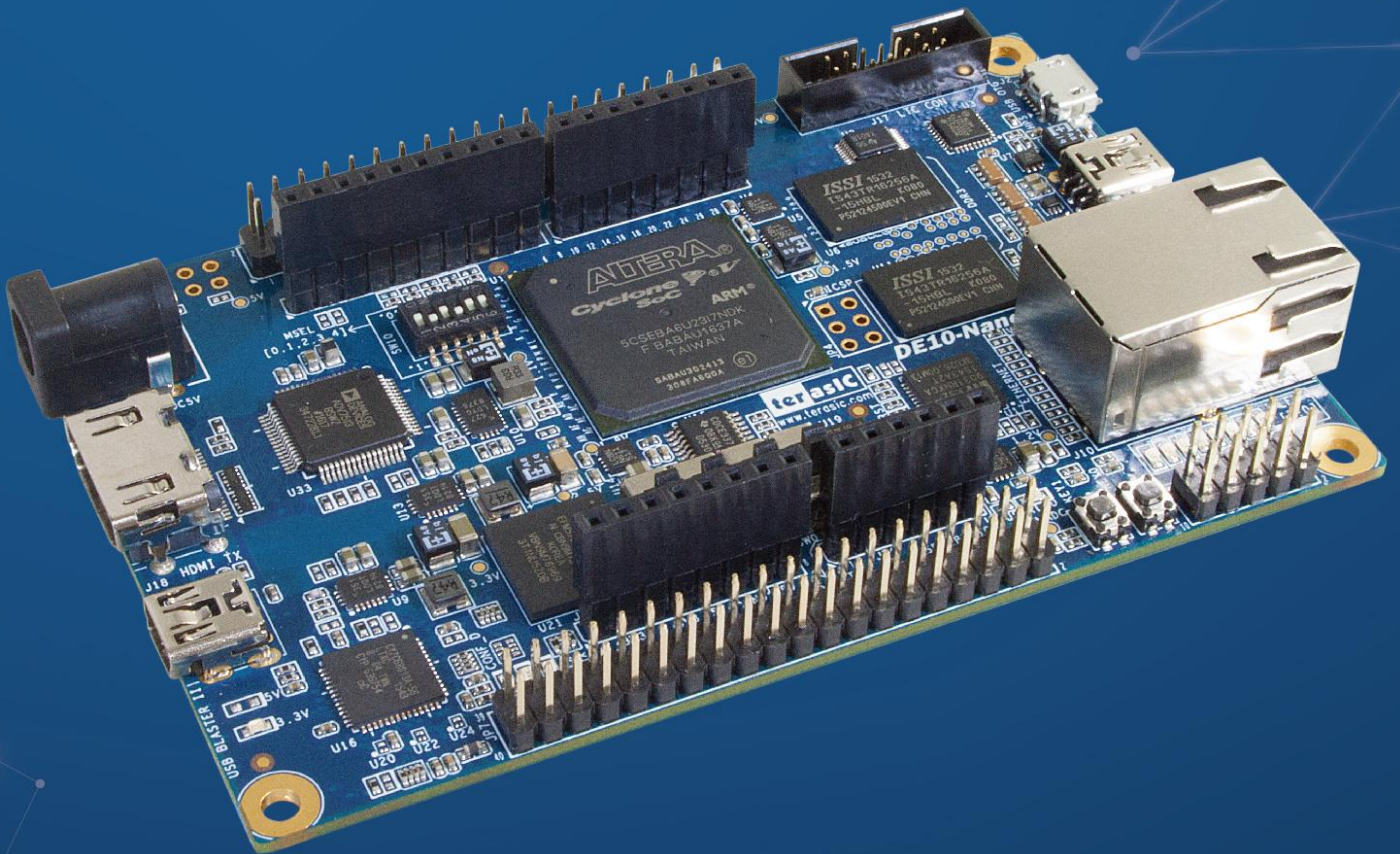

Copyright © 2003-2017 Terasic Inc. All Rights Reserved.

terasic

asic

DE10-Nano

CONTENT

Chapter 1 DE10-Nano Development Kit	3
1.1 Package Contents	3
1.2 DE10-Nano System CD	4
1.3 Getting Help	4
Chapter 2 Introduction of the DE10-Nano Board	5
2.1 Layout and Components	5
2.2 Block Diagram of the DE10-Nano Board	8
Chapter 3 Using the DE10-Nano Board	11
3.1 Settings of FPGA Configuration Mode	11
3.2 Configuration of Cyclone V SoC FPGA on DE10-Nano	13
3.3 Board Status Elements	20
3.4 Board Reset Elements	21
3.5 Clock Circuitry	22
3.6 Peripherals Connected to the FPGA	24
3.6.1 User Push-buttons, Switches and LEDs	24
3.6.2 2x20 GPIO Expansion Headers	27
3.6.3 Arduino Uno R3 Expansion Header	30
3.6.4 A/D Converter and Analog Input	32
3.6.5 HDMI TX Interface	34
3.7 Peripherals Connected to Hard Processor System (HPS)	36
3.7.1 User Push-buttons and LEDs	36
3.7.2 Gigabit Ethernet	36
3.7.3 UART	38
3.7.4 DDR3 Memory	39
3.7.5 Micro SD Card Socket	42
3.7.6 USB 2.0 OTG PHY	43
3.7.7 G-sensor	44
3.7.8 LTC Connector	45
Chapter 4 DE10-Nano System Builder	46
4.1 Introduction	46
4.2 Design Flow	47
4.3 Using DE10-Nano System Builder	48

Chapter 5	Examples For FPGA	54
5.1	DE10-Nano Factory Configuration	54
5.2	ADC Reading	55
5.3	HDMI TX	58
5.4	DDR3_VIP	62
5.5	DDR3_RTL	68
5.6	Nios II Access HPS DDR3	73
Chapter 6	Examples for HPS SoC	78
6.1	Hello Program	78
6.2	Users LED and KEY	81
6.3	I2C Interfaced G-sensor	88
6.4	Setup USB Wi-Fi Dongle	91
6.5	Query Internet Time	94
Chapter 7	Examples for using both HPS SoC and FGPA	96
7.1	Required Background	96
7.2	System Requirements	97
7.3	AXI bridges in Intel SoC FPGA	97
7.4	GHRD Project	99
7.5	Compile and Programming	100
7.6	Develop the C Code	101
Chapter 8	Programming the EPCS Device	107
8.1	Before Programming Begins	107
8.2	Convert .SOF File to .JIC File	108
8.3	Write JIC File into the EPCS Device	113
8.4	Erase the EPCS Device	115
8.5	EPCS Programming via nios-2-flash-programmer	116
Chapter 9	Appendix A	117
9.1	Revision History	117

Chapter 1

DE10-Nano

Development Kit

The DE10-Nano Development Kit presents a robust hardware design platform built around the Intel System-on-Chip (SoC) FPGA, which combines the latest dual-core Cortex-A9 embedded cores with industry-leading programmable logic for ultimate design flexibility. Users can now leverage the power of tremendous re-configurability paired with a high-performance, low-power processor system. Intel's SoC integrates an ARM-based hard processor system (HPS) consisting of processor, peripherals and memory interfaces tied seamlessly with the FPGA fabric using a high-bandwidth interconnect backbone. The DE10-Nano development board is equipped with high-speed DDR3 memory, analog to digital capabilities, Ethernet networking, and much more that promise many exciting applications.

The DE10-Nano Development Kit contains all the tools needed to use the board in conjunction with a computer that runs the Microsoft Windows XP or later.

1.1 Package Contents

Figure 1-1 shows a photograph of the DE10-Nano package.

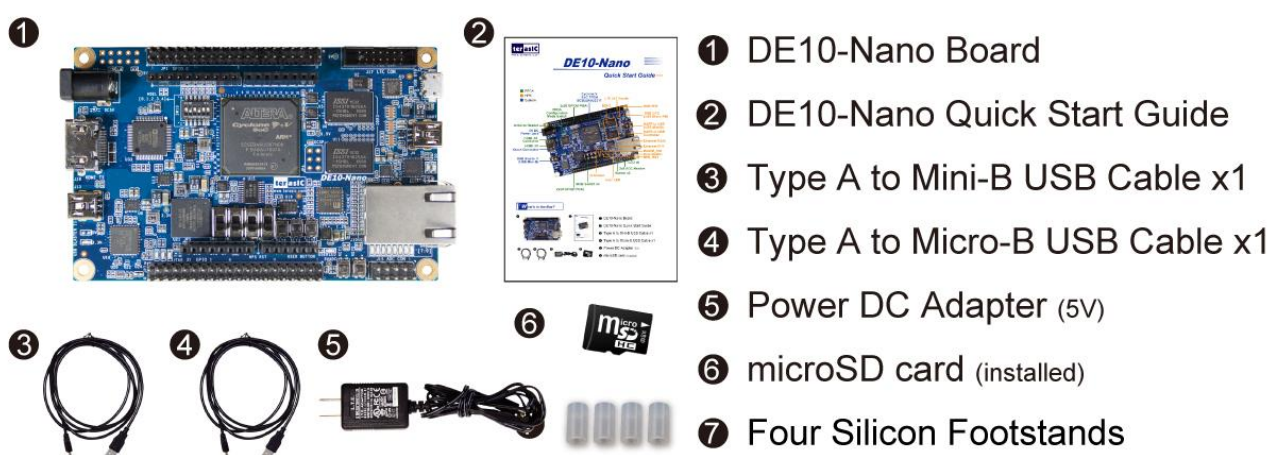

Figure 1-1 The DE10-Nano package contents

The DE10-Nano package includes:

- The DE10-Nano development board
- DE10-Nano Quick Start Guide
- USB cable Type A to Mini-B for FPGA programming or UART control
- USB cable Type A to Micro-B for USB OTG connect to PC
- 5V DC power adapter
- microSD Card (Installed)
- Four Silicon Footstands

1.2 DE10-Nano System CD

The DE10-Nano System CD contains all the documents and supporting materials associated with DE10-Nano, including the user manual, system builder, reference designs, and device datasheets. Users can download this system CD from the link: <http://de10-nano.terasic.com/cd>.

1.3 Getting Help

Here are the addresses where you can get help if you encounter any problems:

Terasic Technologies

9F., No.176, Sec.2, Gongdao 5th Rd, East Dist, Hsinchu City, 30070. Taiwan

Email: support@terasic.com

Tel.: +886-3-575-0880

Website: DE10-Nano.terasic.com

Chapter 2

Introduction of the DE10-Nano Board

This chapter provides an introduction to the features and design characteristics of the board.

2.1 Layout and Components

Figure 2-1 and Figure 2-2 shows a photograph of the board. It depicts the layout of the board and indicates the location of the connectors and key components.

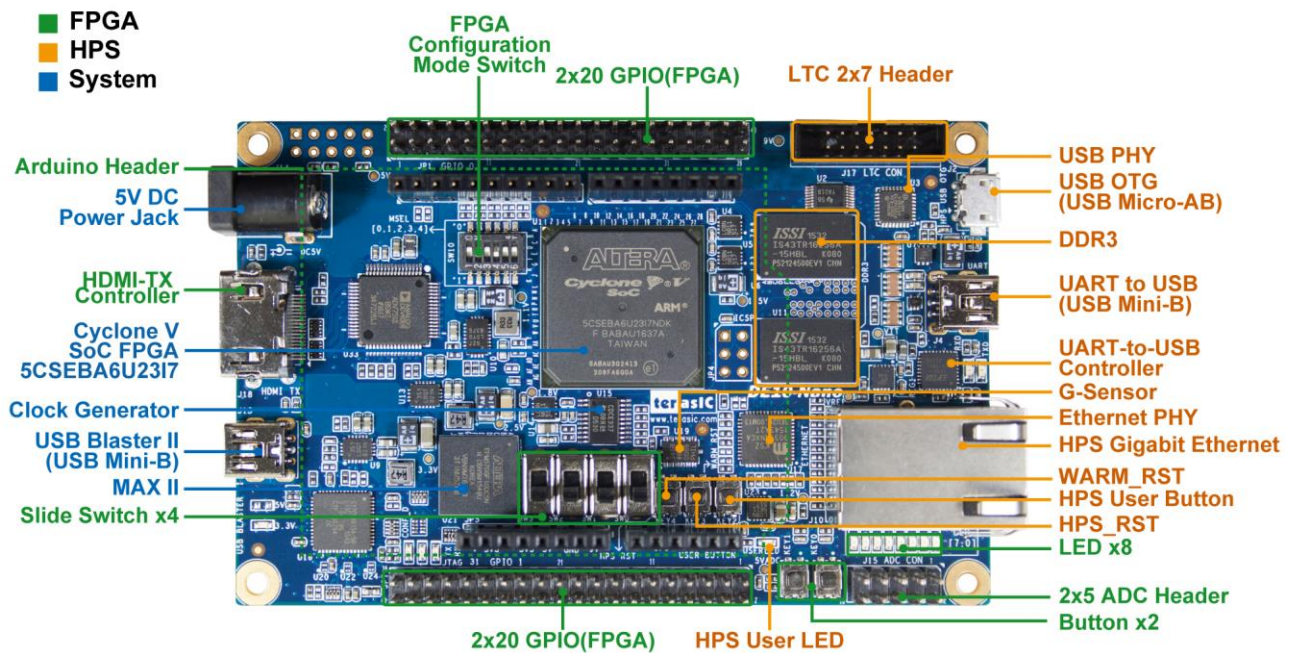

Figure 2-1 DE10-Nano development board (top view)

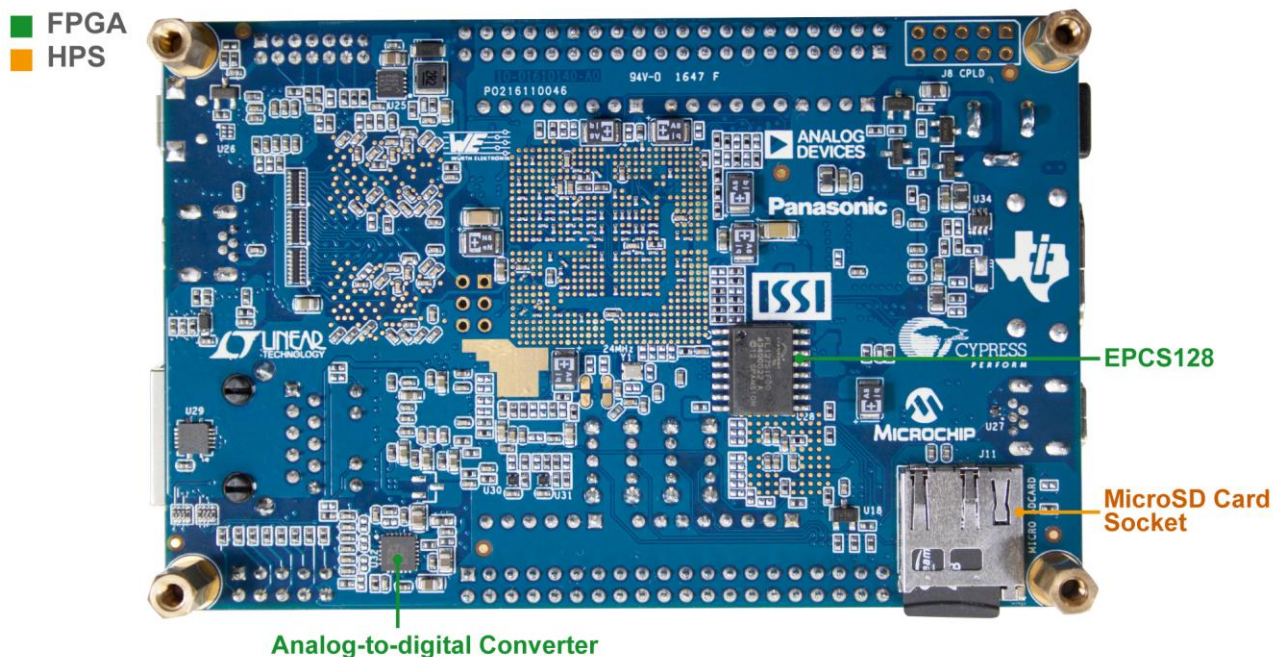

Figure 2-2 DE10-Nano development board (bottom view)

The DE10-Nano board has many features that allow users to implement a wide range of designed circuits, from simple circuits to various multimedia projects.

The following hardware is provided on the board:

■ FPGA

- Cyclone® V SE 5CSEBA6U23I7 device
- Serial configuration device – EPCS128
- USB-Blaster II onboard for programming; JTAG Mode
- 2 push-buttons
- 4 slide switches
- 8 green user LEDs
- Three 50MHz clock sources from the clock generator
- Two 40-pin expansion header
- One Arduino expansion header (Uno R3 compatibility), can connect with Arduino shields.
- One 10-pin Analog input expansion header. (shared with Arduino Analog input)
- A/D converter, 4-wire SPI interface with FPGA
- HDMI TX, compatible with DVI v1.0 and HDCP v1.4

■ HPS (Hard Processor System)

- 800MHz Dual-core ARM Cortex-A9 processor
- 1GB DDR3 SDRAM (32-bit data bus)
- 1 Gigabit Ethernet PHY with RJ45 connector
- port USB OTG, USB Micro-AB connector
- Micro SD card socket
- Accelerometer (I2C interface + interrupt)
- UART to USB, USB Mini-B connector
- Warm reset button and cold reset button
- One user button and one user LED
- LTC 2x7 expansion header

2.2 Block Diagram of the DE10-Nano Board

Figure 2-3 is the block diagram of the board. All the connections are established through the Cyclone V SoC FPGA device to provide maximum flexibility for users. Users can configure the FPGA to implement any system design.

Detailed information about Figure 2-3 are listed below.

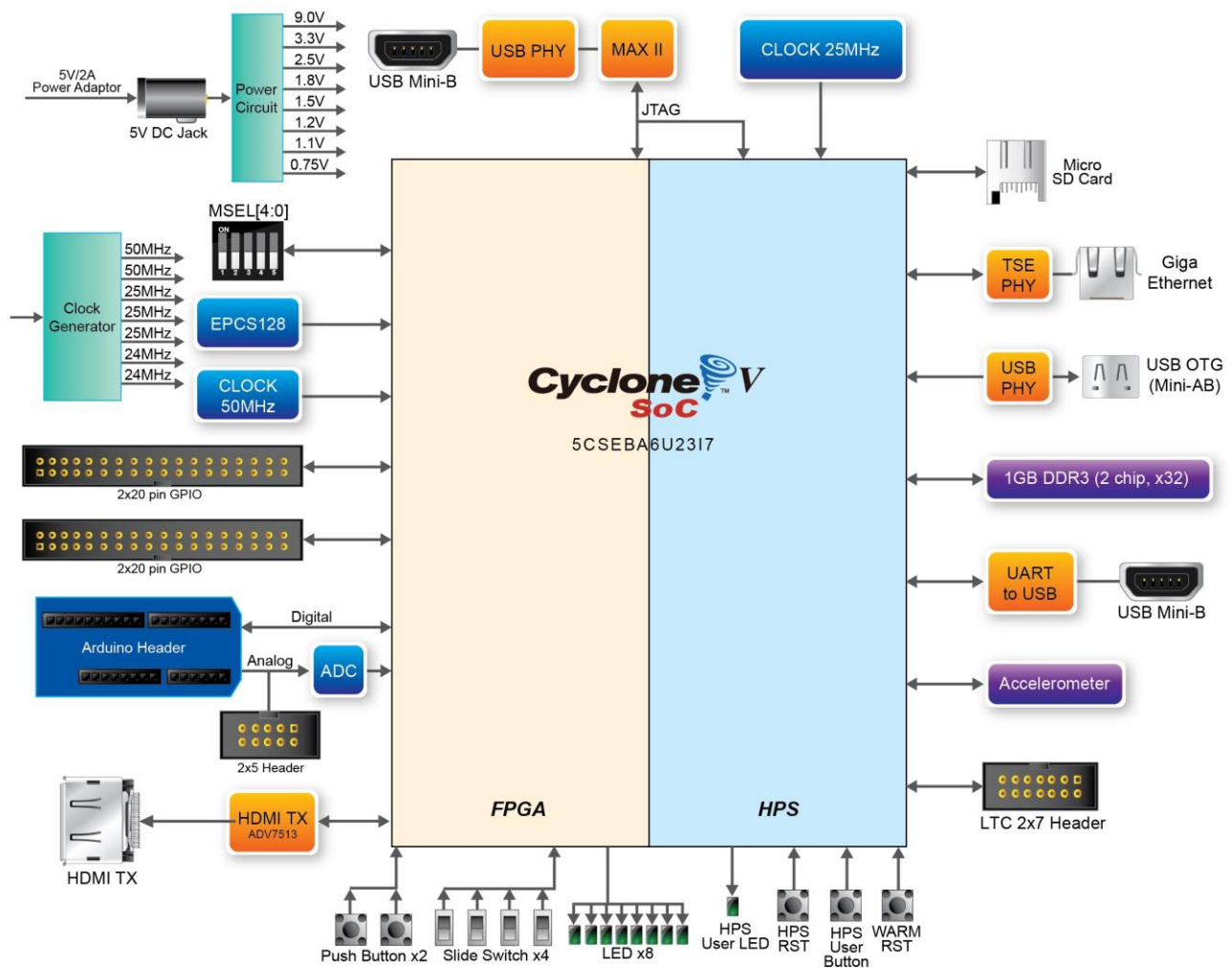

Figure 2-3 Block diagram of DE10-Nano

FPGA Device

- Cyclone V SoC 5CSEBA6U23I7 Device
- Dual-core ARM Cortex-A9 (HPS)
- 110K programmable logic elements
- 5,570 Kbits embedded memory
- 6 fractional PLLs

Configuration and Debug

- Serial configuration device – EPCS128 on FPGA
- Onboard USB-Blaster II (Mini-B USB connector)

Memory Device

- 1GB (2x256Mx16) DDR3 SDRAM on HPS
- Micro SD card socket on HPS

Communication

- One USB 2.0 OTG (ULPI interface with USB Micro-AB connector)
- UART to USB (USB Mini-B connector)
- 10/100/1000 Ethernet

Connectors

- Two 40-pin expansion headers
- Arduino expansion header
- One 10-pin ADC input header
- One LTC connector (one Serial Peripheral Interface (SPI) Master ,one I2C and one GPIO interface)

Display

- HDMI TX, compatible with DVI v1.0 and HDCP v1.4

ADC

- 12-Bit Resolution, 500Ksps Sampling Rate. SPI Interface.
- 8-Channel Analog Input. Input Range : 0V ~ 4.096V.

Switches, Buttons, and Indicators

- 3 user Keys (FPGA x2, HPS x1)
- 4 user switches (FPGA x4)
- 9 user LEDs (FPGA x8, HPS x 1)
- 2 HPS reset buttons (HPS_RESET_n and HPS_WARM_RST_n)

Sensors

- G-Sensor on HPS

Power

- 5V DC input

Chapter 3

Using the DE10-Nano Board

Board

This chapter provides an instruction to use the board and describes the peripherals.

3.1 Settings of FPGA Configuration Mode

When the DE10-Nano board is powered on, the FPGA can be configured from EPCS or HPS.

The MSEL[4:0] pins are used to select the configuration scheme. It is implemented as a 6-pin DIP switch **SW10** on the DE10-Nano board, as shown in **Figure 3-1**.

Table 3-1 shows the relation between MSEL[4:0] and DIP switch (SW10).

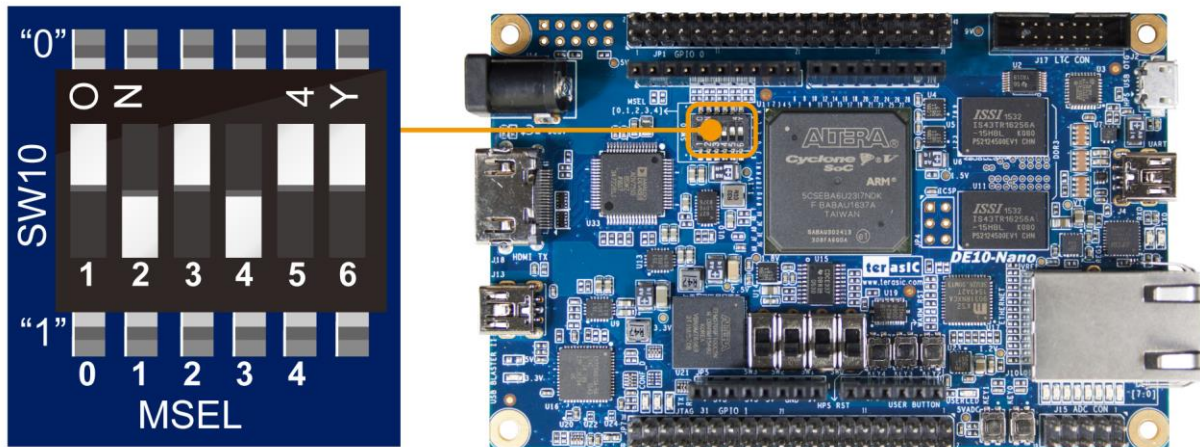

Figure 3-1 DIP switch (SW10) setting of FPPx32 mode.

Table 3-1 FPGA Configuration Mode Switch (SW10)

Board Reference	Signal Name	Description	Default
SW10.1	MSEL0	Use these pins to set the FPGA Configuration scheme	ON ("0")
SW10.2	MSEL1		OFF ("1")
SW10.3	MSEL2		ON ("0")
SW10.4	MSEL3		OFF ("1")
SW10.5	MSEL4		ON ("0")
SW10.6	N/A	N/A	N/A

Table 3-2 shows MSEL[4:0] setting for FPGA configure, and default setting is FPPx32 Mode on DE10-Nano Board.

When the board is powered on and MSEL[4:0] set to "10010", the FPGA is configured from EPCS, which is pre-programmed with the default code. If developers using the "Linux LXDE Desktop" SD Card image, the MSEL[4:0] needs to be set to "01010" before the board is powered on.

Table 3-2 MSEL Pin Settings for FPGA Configure of DE10-Nano Board

Configuration	SW10.1 MSEL0	SW10.2 MSEL1	SW10.3 MSEL2	SW10.4 MSEL3	SW10.5 MSEL4	SW10.6	Description
AS	ON	OFF	ON	ON	OFF	N/A	FPGA configured from EPCS
FPPx32(1) / Compression Enabled / Fast POR (Default)	ON	OFF	ON	OFF	ON	N/A	FPGA configured from HPS software: U-Boot, with image stored on the SD card, like LXDE Desktop (default)
FPPx16 / Compression Disabled / Fast POR	ON	ON	ON	ON	ON	N/A	FPGA configured from HPS software: U-Boot, with image stored on the SD card

(1): Please refer to the following link:

https://www.altera.com/content/dam/altera-www/global/en_US/pdfs/literature/hb/cyclone-v/cv_5v4.pdf , See Table 4-1: Configuration Schemes for FPGA Configuration by the HPS

3.2 Configuration of Cyclone V SoC FPGA on DE10-Nano

There are two types of programming method supported by DE10-Nano:

1. JTAG programming: It is named after the IEEE standards Joint Test Action Group.

The configuration bit stream is downloaded directly into the Cyclone V SoC FPGA. The FPGA will retain its current status as long as the power keeps applying to the board; the configuration information will be lost when the power is off.

2. AS programming: The other programming method is Active Serial configuration.

The configuration bit stream is downloaded into the serial configuration device (EPCS128), which provides non-volatile storage for the bit stream. The information is retained within EPCS128 even if the DE10-Nano board is turned off. When the board is powered on, the configuration data in the EPCS128 device is automatically loaded into the Cyclone V SoC FPGA.

■ JTAG Chain on DE10-Nano Board

The FPGA device can be configured through JTAG interface on DE10-Nano board, but the JTAG chain must form a closed loop, which allows Quartus II programmer to detect FPGA device. **Figure 3-2** illustrates the JTAG chain on DE10-Nano board.

In addition, the DE10-Nano has one external JTAG Header (J8) reserved for users to connect to JTAG chain of the DE10-Nano via external blaster. The J8 header is not installed, so users need to solder a 2.54mm 2 x 5 male pin header if it is necessary.

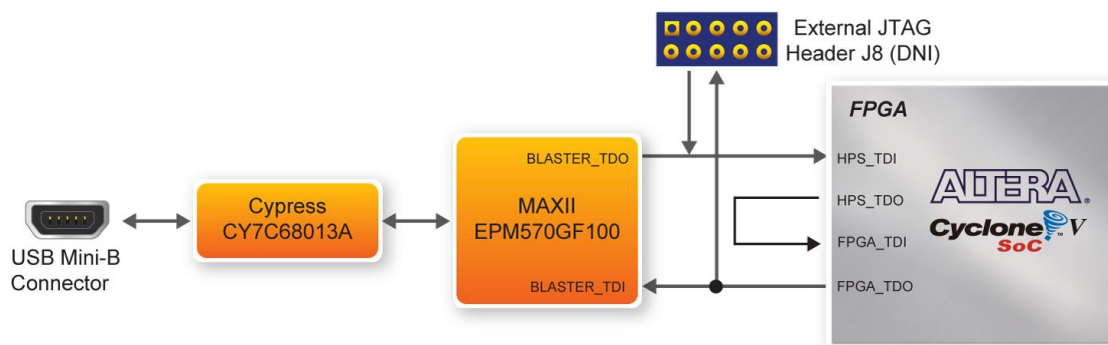

Figure 3-2 Path of the JTAG chain

■ Configure the FPGA in JTAG Mode

There are two devices (FPGA and HPS) on the JTAG chain. The following shows how the FPGA is programmed in JTAG mode step by step.

Open the Quartus II programmer, please Choose **Tools > Programmer**. The Programmer window opens. Please click “**Hardware Setup**”, as circled in **Figure 3-3**.

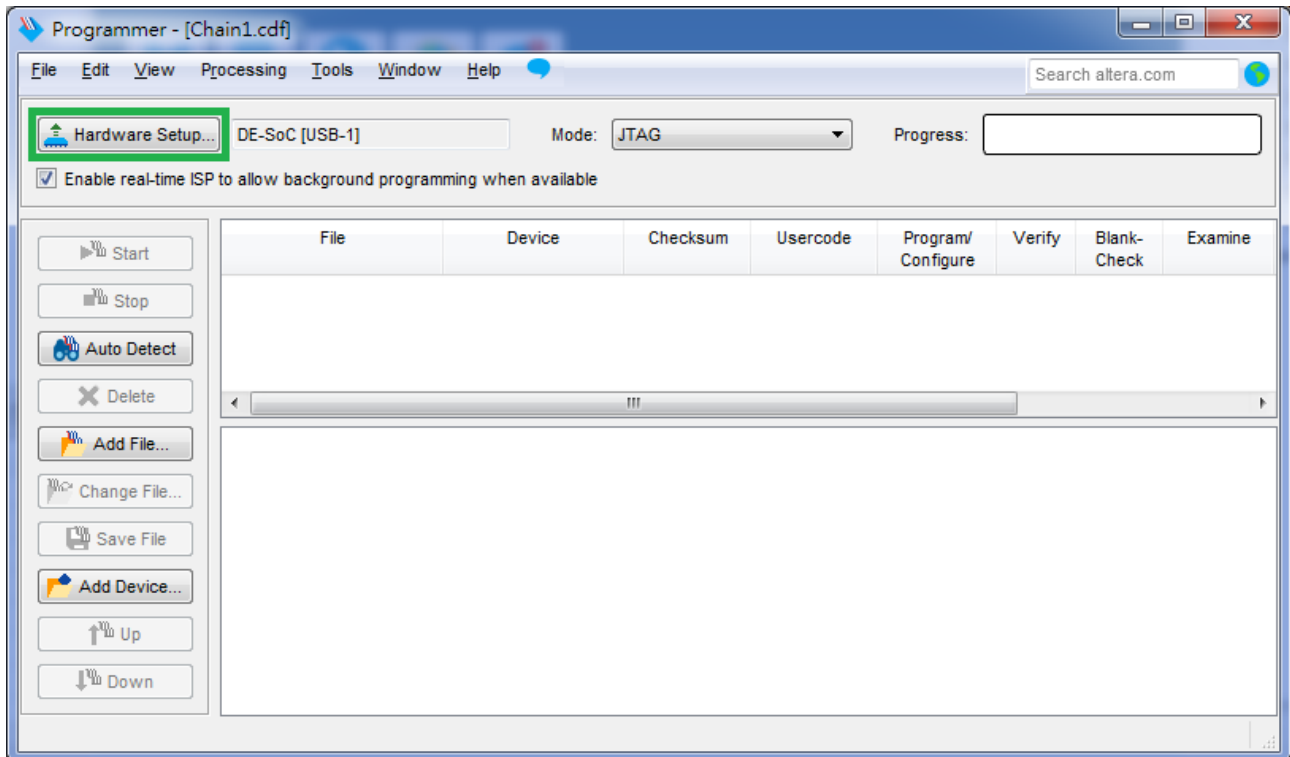

Figure 3-3 Programmer Window

If it is not already turned on, turn on the **DE-SoC [USB-1]** option under currently selected hardware and click “**Close**” to close the window. See **Figure 3-4**.

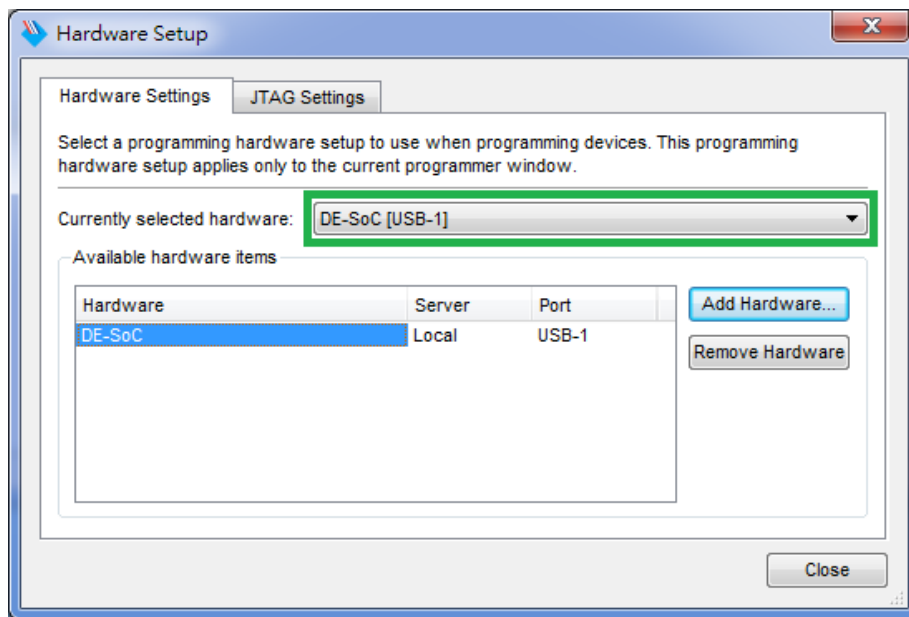

Figure 3-4 Hardware Setting

Return to the Quartus II programmer and click “**Auto Detect**”, as circled in **Figure 3-5**

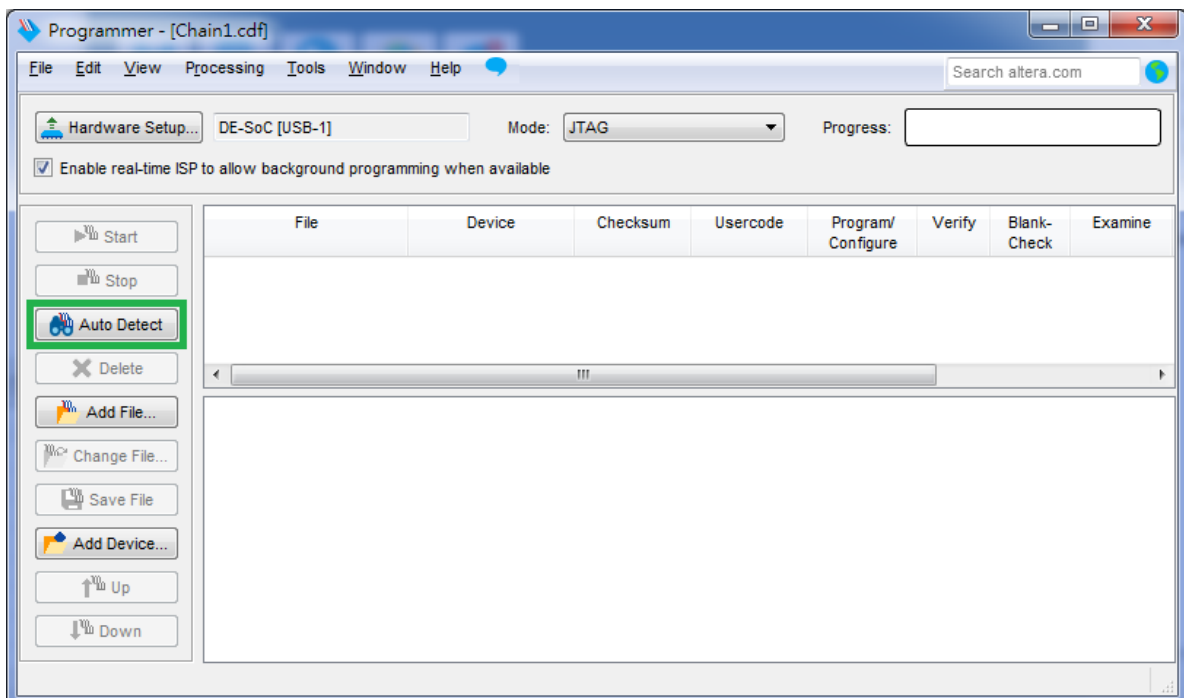

Figure 3-5 Detect FPGA device in JTAG mode

If the device is detected, the window of the selection device is opened, Please select detected device associated with the board and click “OK” to close the window, as circled in **Figure 3-6**.



Figure 3-6 Select 5CSEBA6 device

Both FPGA and HPS are detected, as shown in **Figure 3-7**.

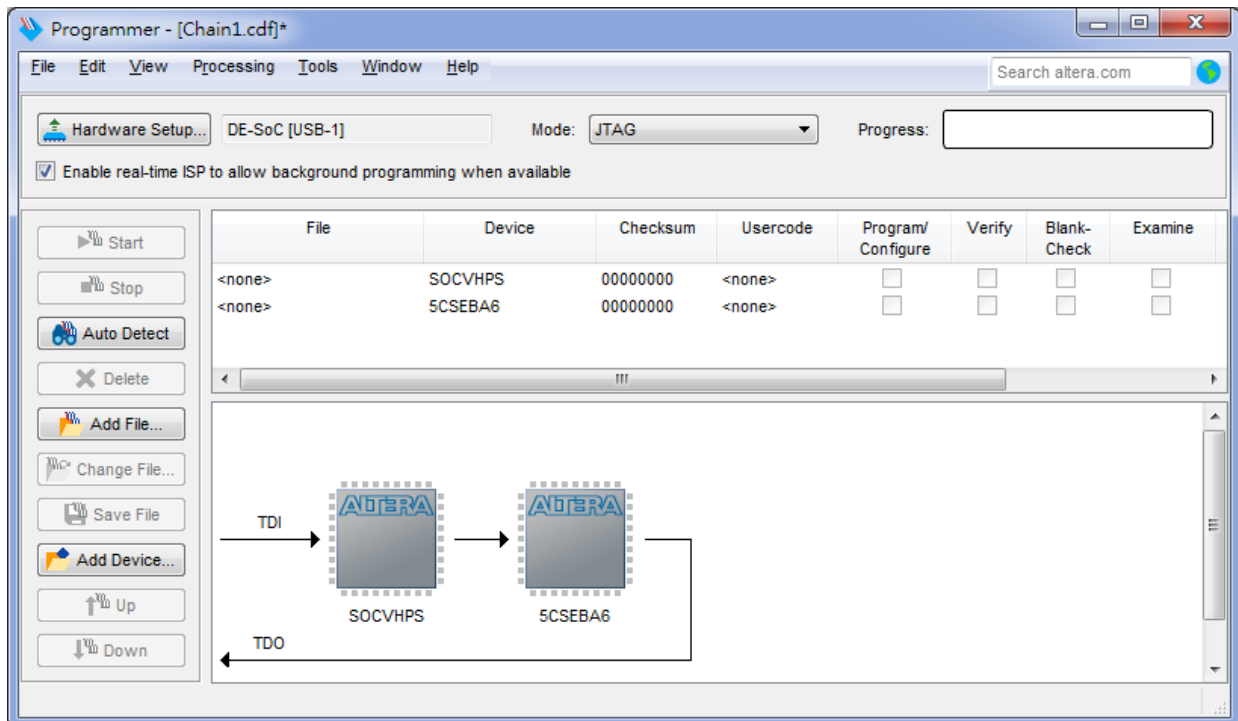

Figure 3-7 FPGA and HPS detected in Quartus programmer

Right click on the FPGA device and open the .sof file to be programmed, as highlighted in **Figure 3-8**.

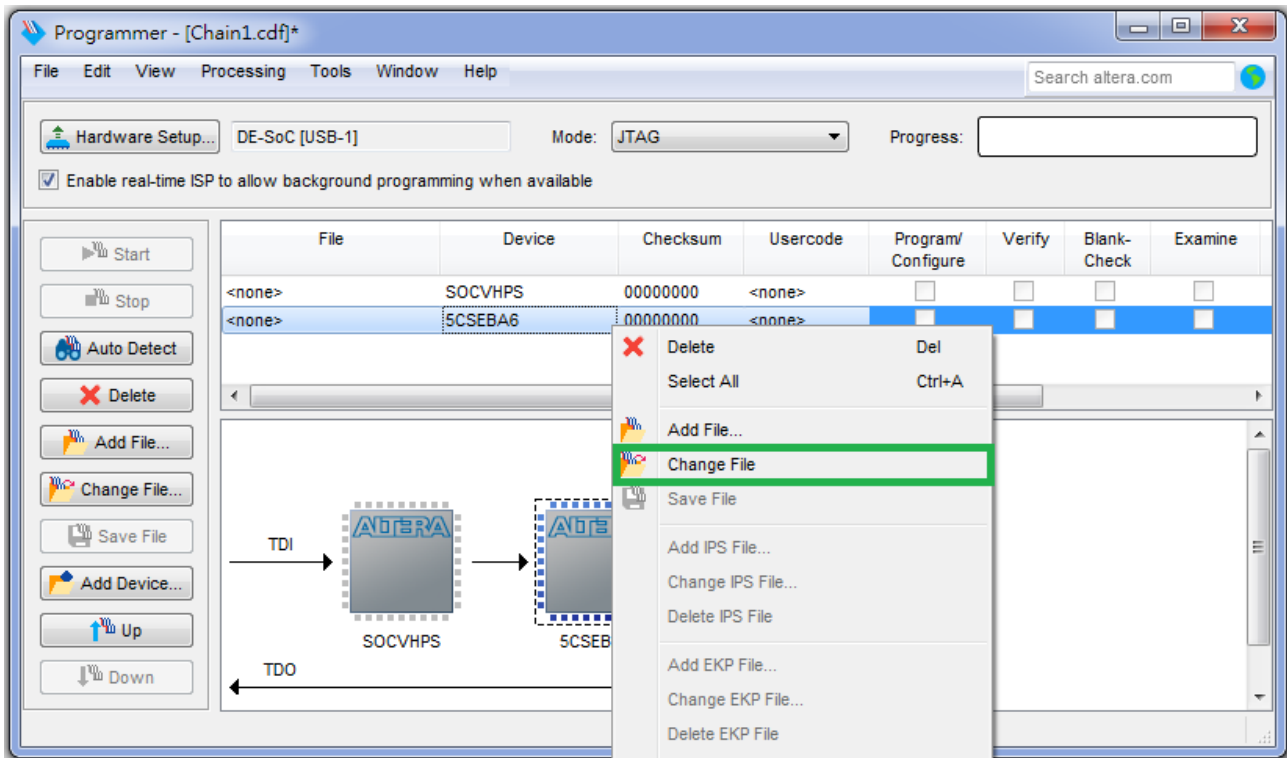

Figure 3-8 Open the .sof file to be programmed into the FPGA device

Select the .sof file to be programmed, as shown in **Figure 3-9**.

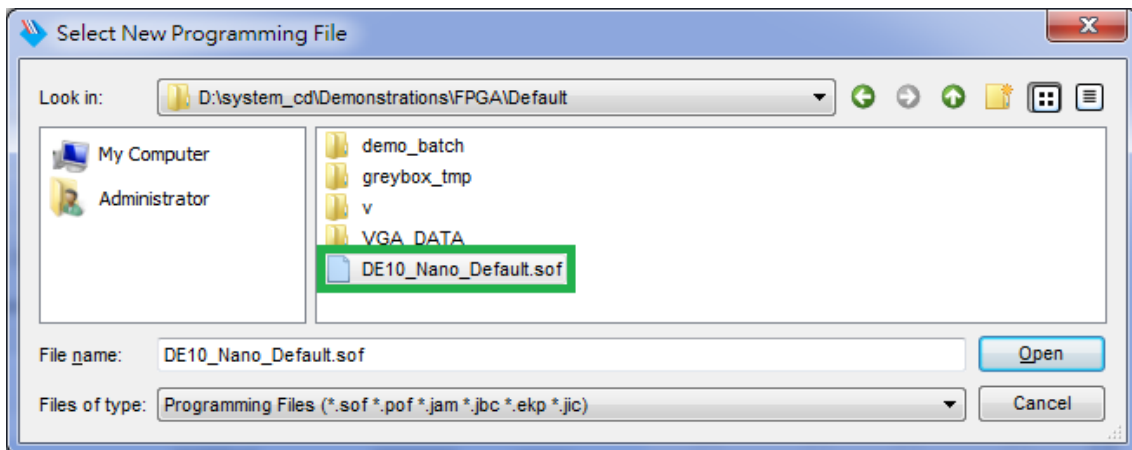

Figure 3-9 Select the .sof file to be programmed into the FPGA device

Click “Program/Configure” check box and then click “Start” button to download the .sof file into the FPGA device, as shown in **Figure 3-10**.

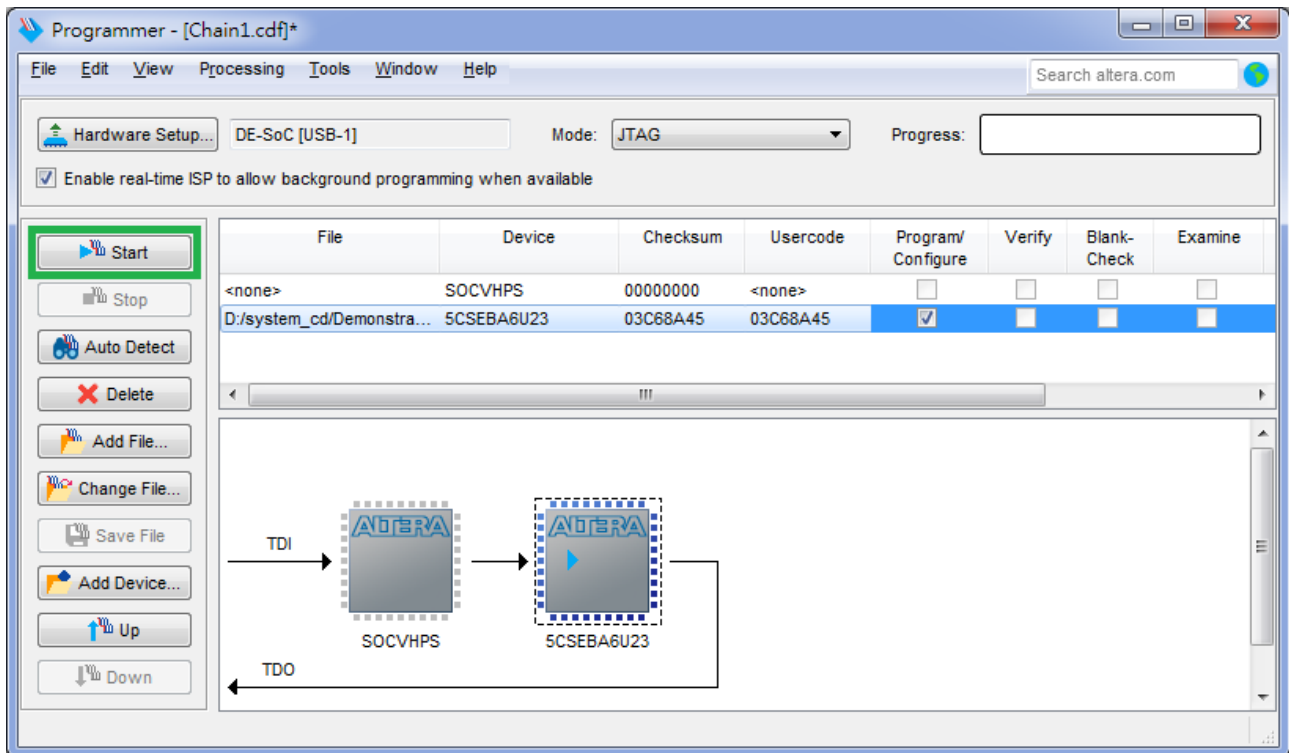

Figure 3-10 Program.sof file into the FPGA device

■ Configure the FPGA in AS Mode

- The DE10-Nano board uses a serial configuration device (EPCS128) to store configuration data for the Cyclone V SoC FPGA. This configuration data is automatically loaded from the serial configuration device chip into the FPGA when the board is powered up.
- Users need to use Serial Flash Loader (SFL) to program the serial configuration device via JTAG interface. The FPGA-based SFL is a soft intellectual property (IP) core within the FPGA that bridge the JTAG and Flash interfaces. The SFL Megafunction is available in Quartus II. **Figure 3-11** shows the programming method when adopting SFL solution.
- Please refer to Chapter 8: Steps of Programming the Serial Configuration Device for the basic programming instruction on the serial configuration device.

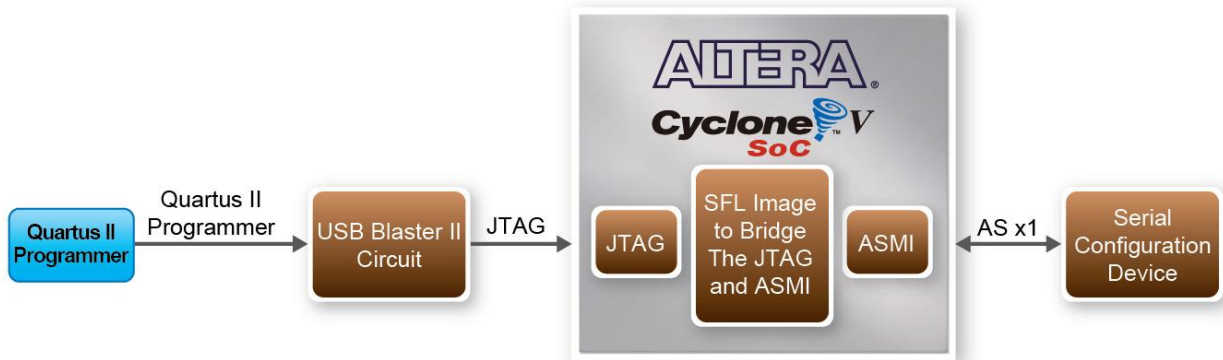

Figure 3-11 Programming a serial configuration device with SFL solution

3.3 Board Status Elements

In addition to the 9 LEDs that FPGA/HPS device can control, there are 6 indicators which can indicate the board status (See **Figure 3-12**), please refer the details in **Table 3-3**



Figure 3-12 LED Indicators on DE10-Nano

Table 3-3 LED Indicators

Board Reference	LED Name	Description
LED9	3.3-V Power	Illuminate when 3.3V power is active.
LED10	CONF_DONE	Illuminates when the FPGA is successfully configured.
LED11	JTAG_TX	Illuminate when data is transferred from JTAG to USB Host.
LED12	JTAG_RX	Illuminate when data is transferred from USB Host to JTAG.
TXD	UART TXD	Illuminate when data is transferred from FT232R to USB Host.
RXD	UART RXD	Illuminate when data is transferred from USB Host to FT232R.

3.4 Board Reset Elements

There are two HPS reset buttons on DE10-Nano, HPS (cold) reset and HPS warm reset, as shown in **Figure 3-13**. **Table 3-4** describes the purpose of these two HPS reset buttons. **Figure 3-14** is the reset tree for DE10-Nano.

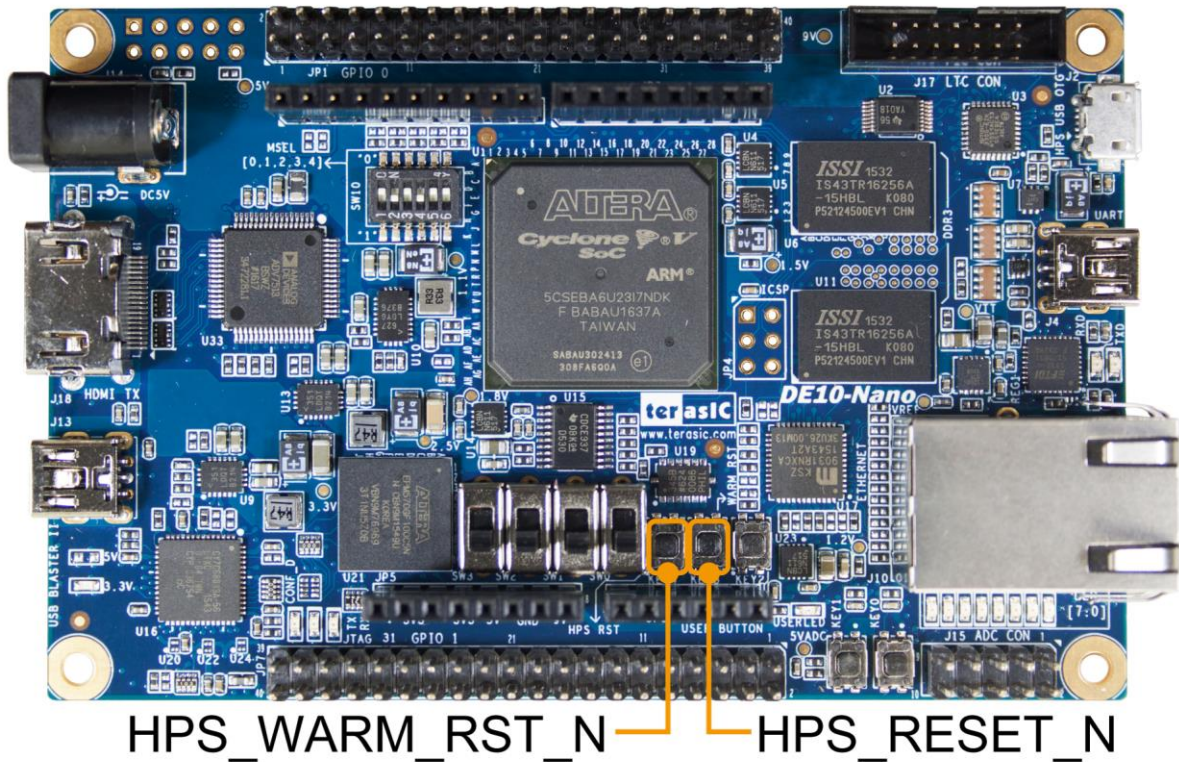

Figure 3-13 HPS cold reset and warm reset buttons on DE10-Nano

Table 3-4 Description of Two HPS Reset Buttons on DE10-Nano

Board Reference	Signal Name	Description
KEY4	HPS_RESET_N	Cold reset to the HPS, Ethernet PHY and USB host device. Active low input which resets all HPS logics that can be reset.
KEY3	HPS_WARM_RST_N	Warm reset to the HPS block. Active low input affects the system reset domain for debug purpose.

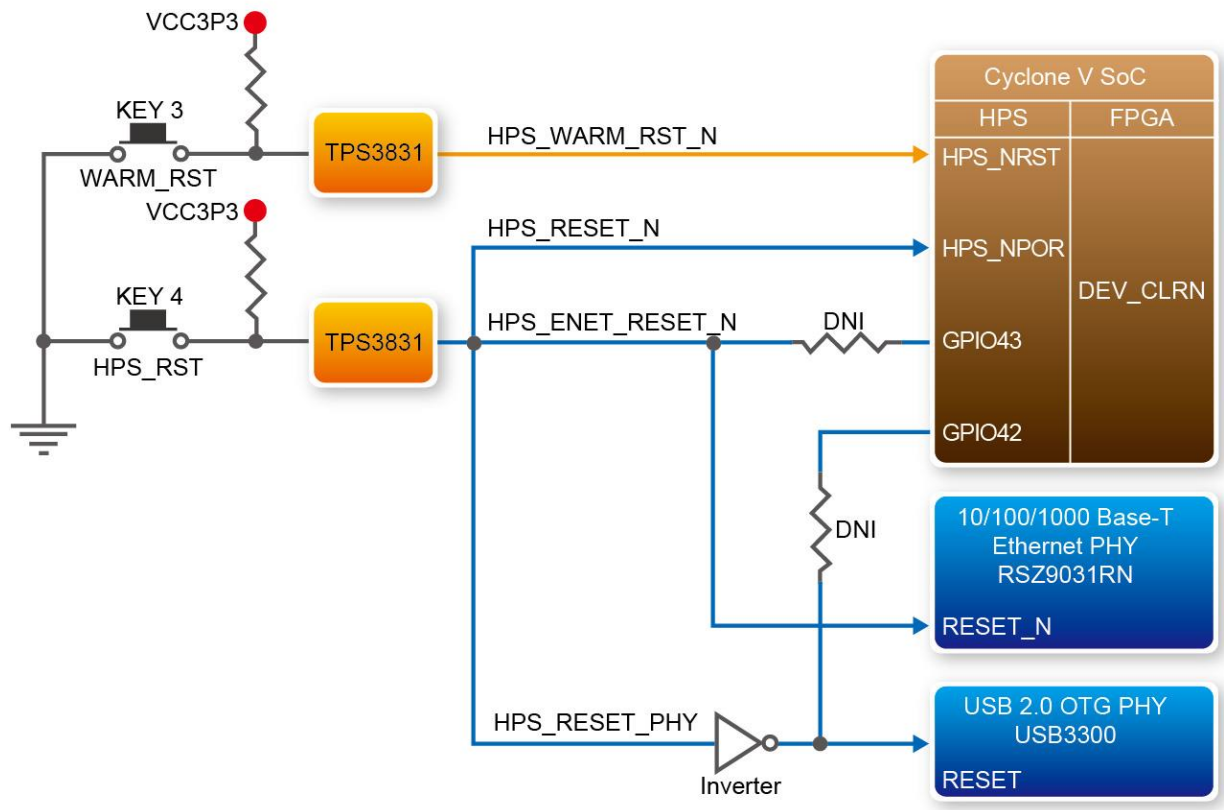

Figure 3-14 HPS reset tree on DE10-Nano board

3.5 Clock Circuitry

Figure 3-15 shows the default frequency of all external clocks to the Cyclone V SoC FPGA. A clock generator is used to distribute clock signals with low jitter. The two 50MHz clock signals connected to the FPGA are used as clock sources for user logic. Three 25MHz clock signals are connected to two HPS clock inputs, and the other one is connected to the clock input of Gigabit Ethernet Transceiver. One 24MHz clock signal is connected to the USB controller for USB Blaster II circuit and FPGA. One 24MHz clock signals are connected to the clock inputs of USB OTG PHY. The associated pin assignment for clock inputs to FPGA I/O pins is listed in Table 3-5.

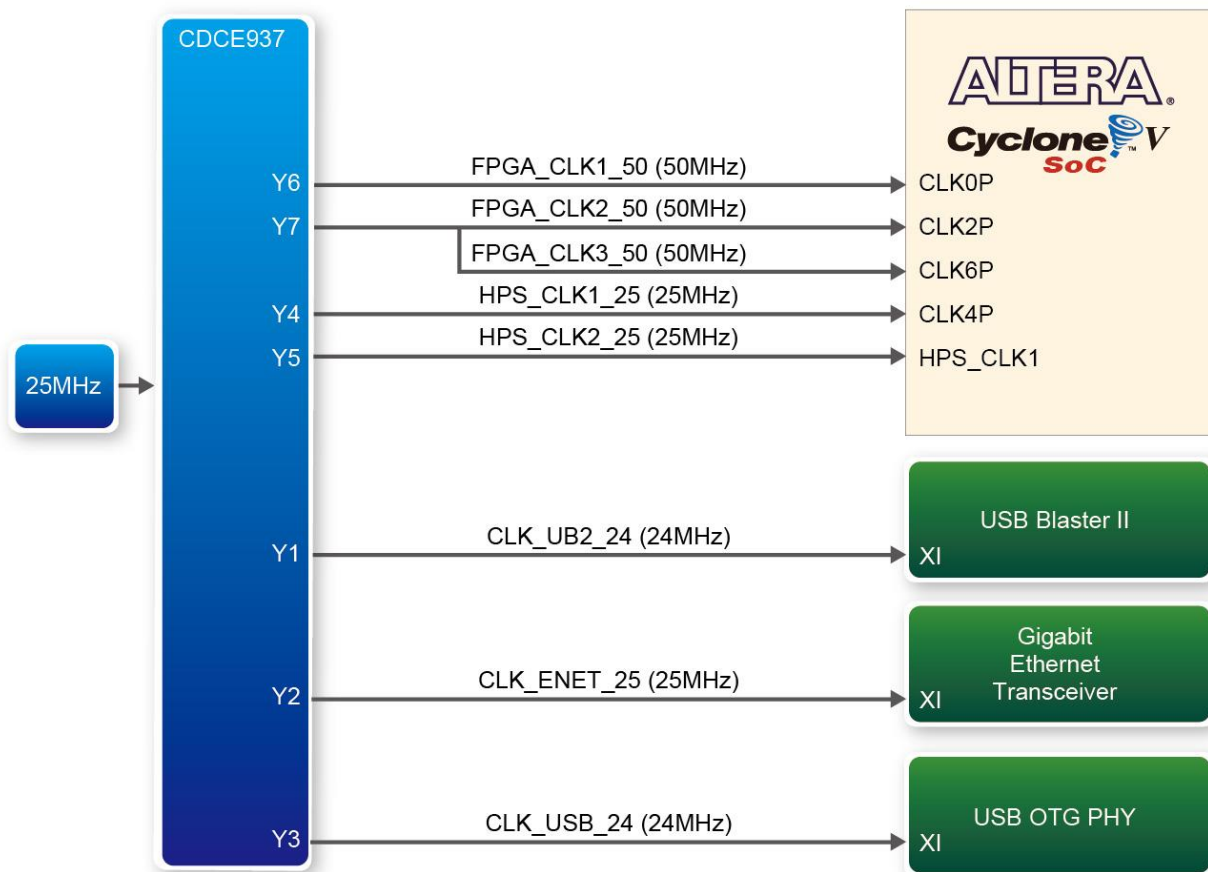

Figure 3-15 Block diagram of the clock distribution on DE10-Nano

Table 3-5 Pin Assignment of Clock Inputs

Signal Name	FPGA Pin No.	Description	I/O Standard
FPGA_CLK1_50	PIN_V11	50 MHz clock input	3.3V
FPGA_CLK2_50	PIN_Y13	50 MHz clock input	3.3V
FPGA_CLK3_50	PIN_E11	50 MHz clock input (share with FPGA_CLK1_50)	3.3V
HPS_CLK1_25	PIN_E20	25 MHz clock input	3.3V
HPS_CLK2_25	PIN_D20	25 MHz clock input	3.3V

3.6 Peripherals Connected to the FPGA

This section describes the interfaces connected to the FPGA. Users can control or monitor different interfaces with user logic from the FPGA.

3.6.1 User Push-buttons, Switches and LEDs

The board has two push-buttons connected to the FPGA, as shown in **Figure 3-16**. Schmitt trigger circuit is implemented and act as switch debounce in **Figure 3-17** for the push-buttons connected. The two push-buttons named KEY0 and KEY1 coming out of the Schmitt trigger device are connected directly to the Cyclone V SoC FPGA. The push-button generates a low logic level or high logic level when it is pressed or not, respectively. Since the push-buttons are debounced, they can be used as clock or reset inputs in a circuit.

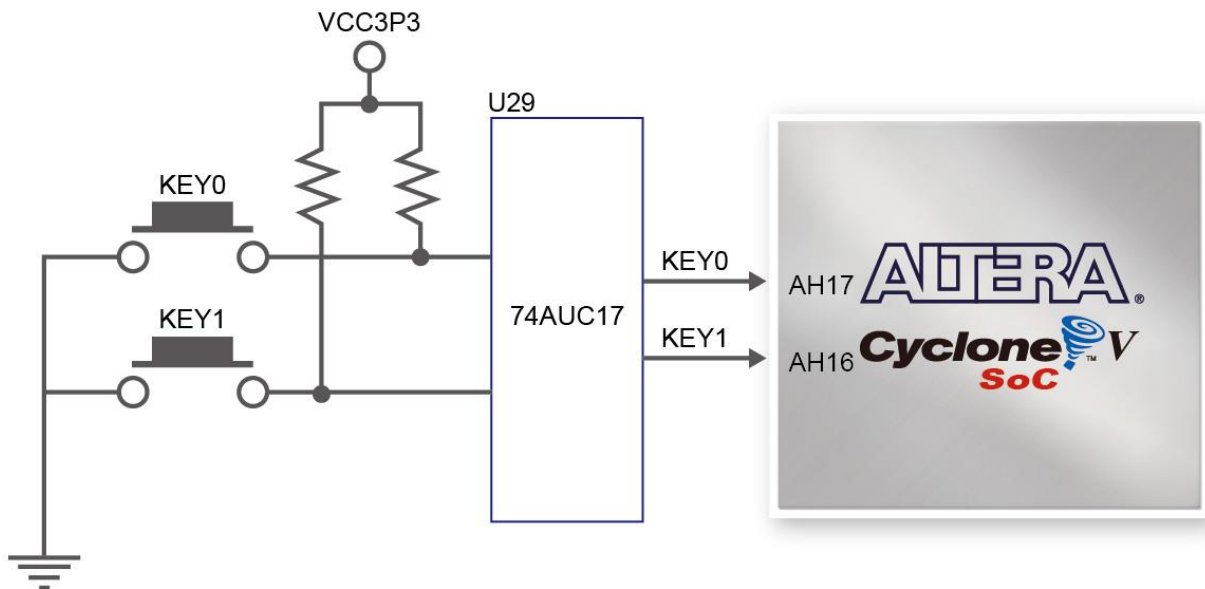

Figure 3-16 Connections between the push-buttons and the Cyclone V SoC FPGA

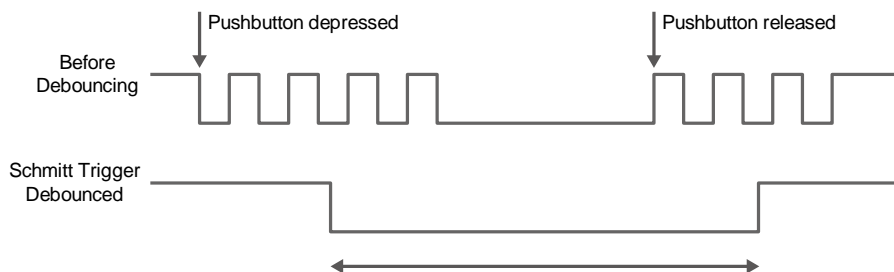

Figure 3-17 Switch debouncing

There are four slide switches connected to the FPGA, as shown in **Figure 3-18**. These switches are not debounced and to be used as level-sensitive data inputs to a circuit. Each switch is connected directly and individually to the FPGA. When the switch is set to the DOWN position (towards the edge of the board), it generates a low logic level to the FPGA. When the switch is set to the UP position, a high logic level is generated to the FPGA.



Figure 3-18 Connections between the slide switches and the Cyclone V SoC FPGA

There are also eight user-controllable LEDs connected to the FPGA. Each LED is driven directly and individually by the Cyclone V SoC FPGA; driving its associated pin to a high logic level or low level to turn the LED on or off, respectively. **Figure 3-19** shows the connections between LEDs and Cyclone V SoC FPGA. **Table 3-6**, **Table 3-7** and **Table 3-8** list the pin assignment of user push-buttons, switches, and LEDs.

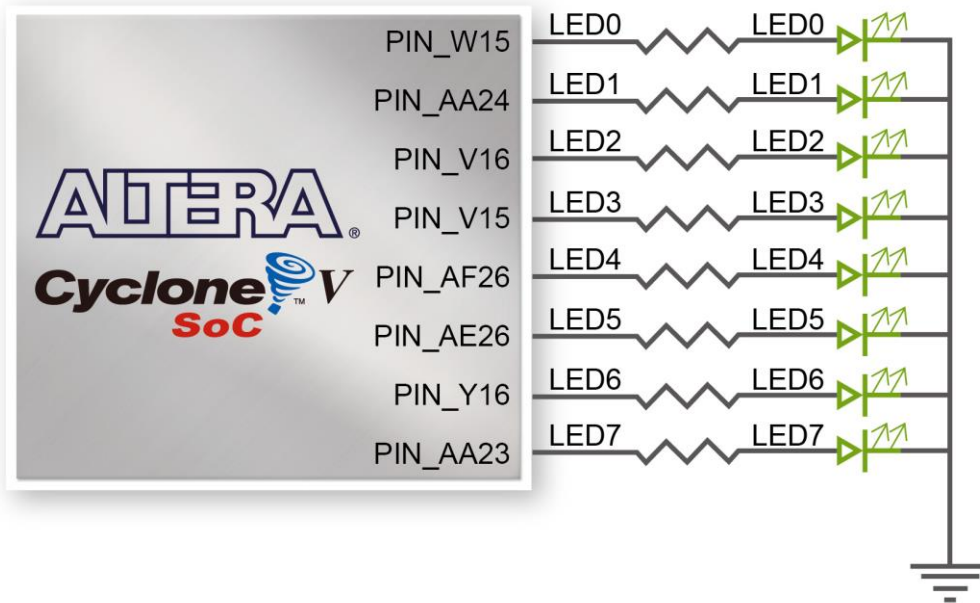

Figure 3-19 Connections between the LEDs and the Cyclone V SoC FPGA

Table 3-6 Pin Assignment of Slide Switches

Signal Name	FPGA Pin No.	Description	I/O Standard
SW[0]	PIN_Y24	Slide Switch[0]	3.3V
SW[1]	PIN_W24	Slide Switch[1]	3.3V
SW[2]	PIN_W21	Slide Switch[2]	3.3V
SW[3]	PIN_W20	Slide Switch[3]	3.3V

Table 3-7 Pin Assignment of Push-buttons

Signal Name	FPGA Pin No.	Description	I/O Standard
KEY[0]	PIN_AH17	Push-button[0]	3.3V
KEY[1]	PIN_AH16	Push-button[1]	3.3V

Table 3-8 Pin Assignment of LEDs

Signal Name	FPGA Pin No.	Description	I/O Standard
LED[0]	PIN_W15	LED [0]	3.3V
LED[1]	PIN_AA24	LED [1]	3.3V
LED[2]	PIN_V16	LED [2]	3.3V
LED[3]	PIN_V15	LED [3]	3.3V
LED[4]	PIN_AF26	LED [4]	3.3V
LED[5]	PIN_AE26	LED [5]	3.3V

3.6.2 2x20 GPIO Expansion Headers

The board has two 40-pin expansion headers. Each header has 36 user pins connected directly to the Cyclone V SoC FPGA. It also comes with DC +5V (VCC5), DC +3.3V (VCC3P3), and two GND pins. **Figure 3-20** shows the I/O distribution of the GPIO connector. The maximum power consumption allowed for a daughter card connected to one or two GPIO ports is shown in **Table 3-9** and **Table 3-10** shows all the pin assignments of the GPIO connector.

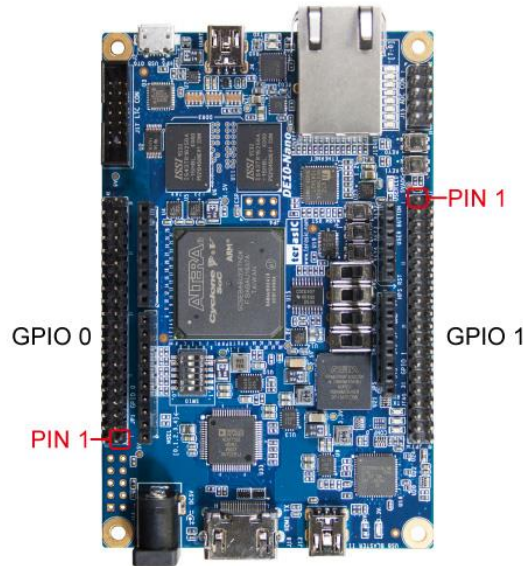

GPIO 0 (JP1)				GPIO 1 (JP7)							
PIN_V12	GPIO_0[0]	1	2	GPIO_0[1]	PIN_E8	PIN_Y15	GPIO_1[0]	1	2	GPIO_1[1]	PIN_AC24
PIN_W12	GPIO_0[2]	3	4	GPIO_0[3]	PIN_D11	PIN_AA15	GPIO_1[2]	3	4	GPIO_1[3]	PIN_AD26
PIN_D8	GPIO_0[4]	5	6	GPIO_0[5]	PIN_AH13	PIN_AG28	GPIO_1[4]	5	6	GPIO_1[5]	PIN_AF28
PIN_AF7	GPIO_0[6]	7	8	GPIO_0[7]	PIN_AH14	PIN_AE25	GPIO_1[6]	7	8	GPIO_1[7]	PIN_AF27
PIN_AF4	GPIO_0[8]	9	10	GPIO_0[9]	PIN_AH3	PIN_AG26	GPIO_1[8]	9	10	GPIO_1[9]	PIN_AH27
	5V	11	12	GND			5V	11	12	GND	
PIN_AD5	GPIO_0[10]	13	14	GPIO_0[11]	PIN_AG14	PIN_AG25	GPIO_1[10]	13	14	GPIO_1[11]	PIN_AH26
PIN_AE23	GPIO_0[12]	15	16	GPIO_0[13]	PIN_AE6	PIN_AH24	GPIO_1[12]	15	16	GPIO_1[13]	PIN_AF25
PIN_AD23	GPIO_0[14]	17	18	GPIO_0[15]	PIN_AE24	PIN_AG23	GPIO_1[14]	17	18	GPIO_1[15]	PIN_AF23
PIN_D12	GPIO_0[16]	19	20	GPIO_0[17]	PIN_AD20	PIN_AG24	GPIO_1[16]	19	20	GPIO_1[17]	PIN_AH22
PIN_C12	GPIO_0[18]	21	22	GPIO_0[19]	PIN_AD17	PIN_AH21	GPIO_1[18]	21	22	GPIO_1[19]	PIN_AG21
PIN_AC23	GPIO_0[20]	23	24	GPIO_0[21]	PIN_AC22	PIN_AH23	GPIO_1[20]	23	24	GPIO_1[21]	PIN_AA20
PIN_Y19	GPIO_0[22]	25	26	GPIO_0[23]	PIN_AB23	PIN_AF22	GPIO_1[22]	25	26	GPIO_1[23]	PIN_AE22
PIN_AA19	GPIO_0[24]	27	28	GPIO_0[25]	PIN_W11	PIN_AG20	GPIO_1[24]	27	28	GPIO_1[25]	PIN_AF21
	3.3V	29	30	GND			3.3V	29	30	GND	
PIN_AA18	GPIO_0[26]	31	32	GPIO_0[27]	PIN_W14	PIN_AG19	GPIO_1[26]	31	32	GPIO_1[27]	PIN_AH19
PIN_Y18	GPIO_0[28]	33	34	GPIO_0[29]	PIN_Y17	PIN_AG18	GPIO_1[28]	33	34	GPIO_1[29]	PIN_AH18
PIN_AB25	GPIO_0[30]	35	36	GPIO_0[31]	PIN_AB26	PIN_AF18	GPIO_1[30]	35	36	GPIO_1[31]	PIN_AF20
PIN_Y11	GPIO_0[32]	37	38	GPIO_0[33]	PIN_AA26	PIN_AG15	GPIO_1[32]	37	38	GPIO_1[33]	PIN_AE20
PIN_AA13	GPIO_0[34]	39	40	GPIO_0[35]	PIN_AA11	PIN_AE19	GPIO_1[34]	39	40	GPIO_1[35]	PIN_AE17

Figure 3-20 GPIO Pin Arrangement

Table 3-9 Voltage and Max. Current Limit of Expansion Header(s)

Supplied Voltage	Max. Current Limit
5V	1A (depend on the power adapter specification.)
3.3V	1.5A

Table 3-10 Show all Pin Assignment of Expansion Headers

Signal Name	FPGA Pin No.	Description	I/O Standard
GPIO_0[0]	PIN_V12	GPIO Connection 0[0]	3.3V
GPIO_0[1]	PIN_E8	GPIO Connection 0[1]	3.3V
GPIO_0[2]	PIN_W12	GPIO Connection 0[2]	3.3V
GPIO_0[3]	PIN_D11	GPIO Connection 0[3]	3.3V
GPIO_0[4]	PIN_D8	GPIO Connection 0[4]	3.3V
GPIO_0[5]	PIN_AH13	GPIO Connection 0[5]	3.3V
GPIO_0[6]	PIN_AF7	GPIO Connection 0[6]	3.3V
GPIO_0[7]	PIN_AH14	GPIO Connection 0[7]	3.3V
GPIO_0[8]	PIN_AF4	GPIO Connection 0[8]	3.3V
GPIO_0[9]	PIN_AH3	GPIO Connection 0[9]	3.3V
GPIO_0[10]	PIN_AD5	GPIO Connection 0[10]	3.3V
GPIO_0[11]	PIN_AG14	GPIO Connection 0[11]	3.3V
GPIO_0[12]	PIN_AE23	GPIO Connection 0[12]	3.3V
GPIO_0[13]	PIN_AE6	GPIO Connection 0[13]	3.3V
GPIO_0[14]	PIN_AD23	GPIO Connection 0[14]	3.3V
GPIO_0[15]	PIN_AE24	GPIO Connection 0[15]	3.3V
GPIO_0[16]	PIN_D12	GPIO Connection 0[16]	3.3V
GPIO_0[17]	PIN_AD20	GPIO Connection 0[17]	3.3V
GPIO_0[18]	PIN_C12	GPIO Connection 0[18]	3.3V
GPIO_0[19]	PIN_AD17	GPIO Connection 0[19]	3.3V
GPIO_0[20]	PIN_AC23	GPIO Connection 0[20]	3.3V
GPIO_0[21]	PIN_AC22	GPIO Connection 0[21]	3.3V
GPIO_0[22]	PIN_Y19	GPIO Connection 0[22]	3.3V
GPIO_0[23]	PIN_AB23	GPIO Connection 0[23]	3.3V
GPIO_0[24]	PIN_AA19	GPIO Connection 0[24]	3.3V
GPIO_0[25]	PIN_W11	GPIO Connection 0[25]	3.3V
GPIO_0[26]	PIN_AA18	GPIO Connection 0[26]	3.3V
GPIO_0[27]	PIN_W14	GPIO Connection 0[27]	3.3V
GPIO_0[28]	PIN_Y18	GPIO Connection 0[28]	3.3V
GPIO_0[29]	PIN_Y17	GPIO Connection 0[29]	3.3V
GPIO_0[30]	PIN_AB25	GPIO Connection 0[30]	3.3V
GPIO_0[31]	PIN_AB26	GPIO Connection 0[31]	3.3V
GPIO_0[32]	PIN_Y11	GPIO Connection 0[32]	3.3V
GPIO_0[33]	PIN_AA26	GPIO Connection 0[33]	3.3V

GPIO_0[34]	PIN_AA13	GPIO Connection 0[34]	3.3V
GPIO_0[35]	PIN_AA11	GPIO Connection 0[35]	3.3V
GPIO_1[0]	PIN_Y15	GPIO Connection 1[0]	3.3V
GPIO_1[1]	PIN_AC24	GPIO Connection 1[1]	3.3V
GPIO_1[2]	PIN_AA15	GPIO Connection 1[2]	3.3V
GPIO_1[3]	PIN_AD26	GPIO Connection 1[3]	3.3V
GPIO_1[4]	PIN_AG28	GPIO Connection 1[4]	3.3V
GPIO_1[5]	PIN_AF28	GPIO Connection 1[5]	3.3V
GPIO_1[6]	PIN_AE25	GPIO Connection 1[6]	3.3V
GPIO_1[7]	PIN_AF27	GPIO Connection 1[7]	3.3V
GPIO_1[8]	PIN_AG26	GPIO Connection 1[8]	3.3V
GPIO_1[9]	PIN_AH27	GPIO Connection 1[9]	3.3V
GPIO_1[10]	PIN_AG25	GPIO Connection 1[10]	3.3V
GPIO_1[11]	PIN_AH26	GPIO Connection 1[11]	3.3V
GPIO_1[12]	PIN_AH24	GPIO Connection 1[12]	3.3V
GPIO_1[13]	PIN_AF25	GPIO Connection 1[13]	3.3V
GPIO_1[14]	PIN_AG23	GPIO Connection 1[14]	3.3V
GPIO_1[15]	PIN_AF23	GPIO Connection 1[15]	3.3V
GPIO_1[16]	PIN_AG24	GPIO Connection 1[16]	3.3V
GPIO_1[17]	PIN_AH22	GPIO Connection 1[17]	3.3V
GPIO_1[18]	PIN_AH21	GPIO Connection 1[18]	3.3V
GPIO_1[19]	PIN_AG21	GPIO Connection 1[19]	3.3V
GPIO_1[20]	PIN_AH23	GPIO Connection 1[20]	3.3V
GPIO_1[21]	PIN_AA20	GPIO Connection 1[21]	3.3V
GPIO_1[22]	PIN_AF22	GPIO Connection 1[22]	3.3V
GPIO_1[23]	PIN_AE22	GPIO Connection 1[23]	3.3V
GPIO_1[24]	PIN_AG20	GPIO Connection 1[24]	3.3V
GPIO_1[25]	PIN_AF21	GPIO Connection 1[25]	3.3V
GPIO_1[26]	PIN_AG19	GPIO Connection 1[26]	3.3V
GPIO_1[27]	PIN_AH19	GPIO Connection 1[27]	3.3V
GPIO_1[28]	PIN_AG18	GPIO Connection 1[28]	3.3V
GPIO_1[29]	PIN_AH18	GPIO Connection 1[29]	3.3V
GPIO_1[30]	PIN_AF18	GPIO Connection 1[30]	3.3V
GPIO_1[31]	PIN_AF20	GPIO Connection 1[31]	3.3V
GPIO_1[32]	PIN_AG15	GPIO Connection 1[32]	3.3V
GPIO_1[33]	PIN_AE20	GPIO Connection 1[33]	3.3V
GPIO_1[34]	PIN_AE19	GPIO Connection 1[34]	3.3V
GPIO_1[35]	PIN_AE17	GPIO Connection 1[35]	3.3V

3.6.3 Arduino Uno R3 Expansion Header

The board provides Arduino Uno revision 3 compatibility expansion header which comes with four independent headers. The expansion header has 17 user pins (16pins GPIO and 1pin Reset) connected directly to the Cyclone V SoC FPGA. 6-pins Analog input connects to ADC, and also provides DC +9V (VCC9), DC +5V (VCC5), DC +3.3V (VCC3P3 and IOREF), and three GND pins.

Please refer to **Figure 3-21** for detailed pin-out information. The blue font represents the Arduino Uno R3 board pin-out definition.

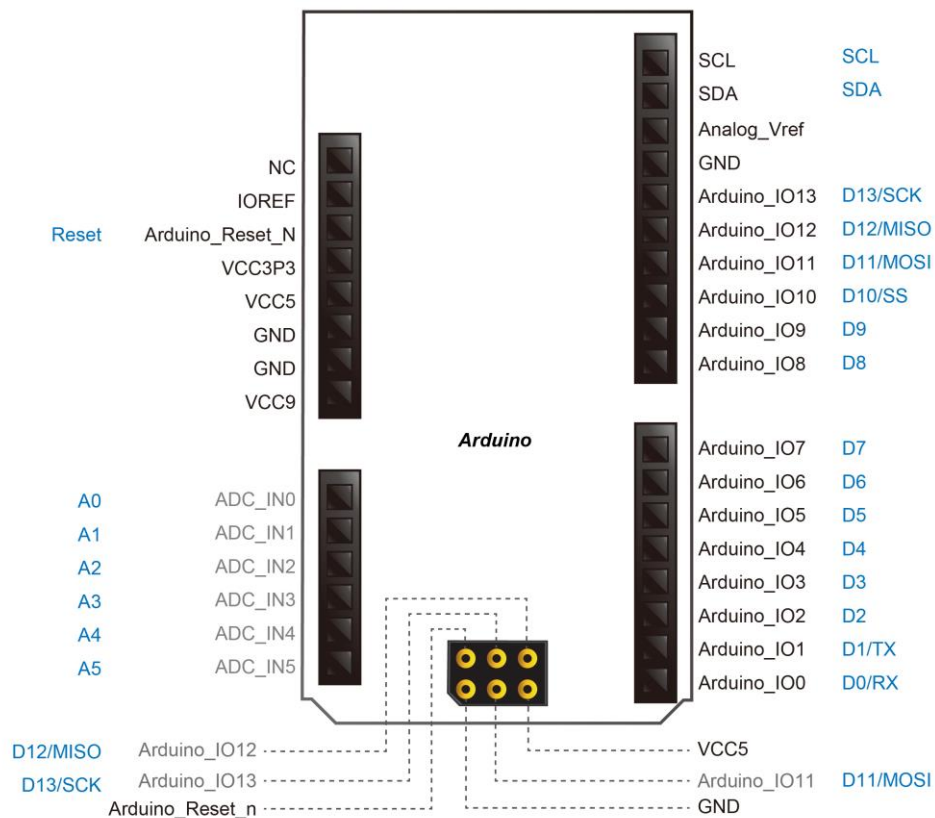

Figure 3-21 lists the all the pin-out signal name of the Arduino Uno connector. The blue font represents the Arduino pin-out definition.

The 16 GPIO pins are provided to the Arduino Header for digital I/O. **Table 3-11** lists the all the pin assignments of the Arduino Uno connector (digital), signal names relative to the Cyclone V SoC FPGA.

Table 3-11 Pin Assignments for Arduino Uno Expansion Header connector

Schematic Signal Name	FPGA Pin No.	Description	Specific features For Arduino	I/O Standard
Arduino_IO0	PIN_AG13	Arduino IO0	RXD	3.3-V
Arduino_IO1	PIN_AF13	Arduino IO1	TXD	3.3-V
Arduino_IO2	PIN_AG10	Arduino IO2		3.3-V
Arduino_IO3	PIN_AG9	Arduino IO3		3.3-V
Arduino_IO4	PIN_U14	Arduino IO4		3.3-V
Arduino_IO5	PIN_U13	Arduino IO5		3.3-V
Arduino_IO6	PIN_AG8	Arduino IO6		3.3-V
Arduino_IO7	PIN_AH8	Arduino IO7		3.3-V
Arduino_IO8	PIN_AF17	Arduino IO8		3.3-V
Arduino_IO9	PIN_AE15	Arduino IO9		3.3-V
Arduino_IO10	PIN_AF15	Arduino IO10	SS	3.3-V
Arduino_IO11	PIN_AG16	Arduino IO11	MOSI	3.3-V
Arduino_IO12	PIN_AH11	Arduino IO12	MISO	3.3-V
Arduino_IO13	PIN_AH12	Arduino IO13	SCK	3.3-V
Arduino_IO14	PIN_AH9	Arduino IO14	SDA	3.3-V
Arduino_IO15	PIN_AG11	Arduino IO15	SCL	3.3-V
Arduino_Reset_n	PIN_AH7	Reset signal, low active.		3.3-V

Besides 16 pins for digital GPIO, there are also 6 analog inputs on the Arduino Uno R3 Expansion Header (ADC_IN0 ~ ADC_IN5). Consequently, we use ADC LTC2308 from Linear Technology on the board for possible future analog-to-digital applications. We will introduce in the next section.

3.6.4 A/D Converter and Analog Input

The DE10-Nano has an analog-to-digital converter (LTC2308).

The LTC2308 is a low noise, 500ksps, 8-channel, 12-bit ADC with a SPI/MICROWIRE compatible serial interface. This ADC includes an internal reference and a fully differential sample-and-hold circuit to reduce common mode noise. The internal conversion clock allows the external serial output data clock (SCK) to operate at any frequency up to 40MHz.

It can be configured to accept eight input signals at inputs ADC_IN0 through ADC_IN7. These eight input signals are connected to a 2x5 header, as shown in **Figure 3-22**.

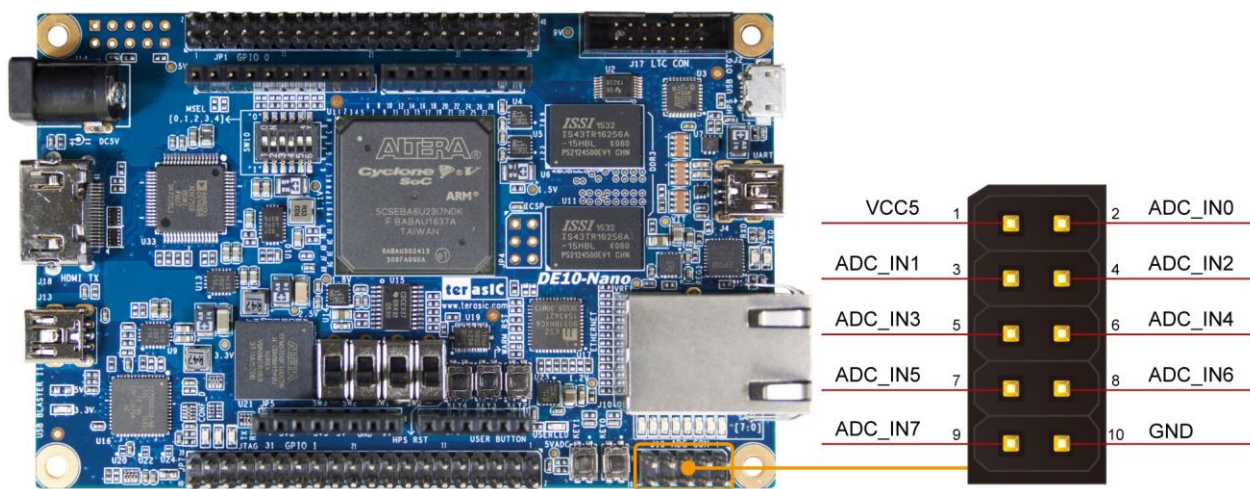

Figure 3-22 Signals of the 2x5 Header

These Analog inputs are shared with the Arduino's analog input pin (ADC_IN0 ~ ADC_IN5), **Figure 3-23** shows the connections between the FPGA, 2x5 header, Arduino Analog input, and the A/D converter.

More information about the A/D converter chip is available in its datasheet. It can be found on manufacturer's website or in the directory \Datasheet\ADC of DE10-Nano system CD.

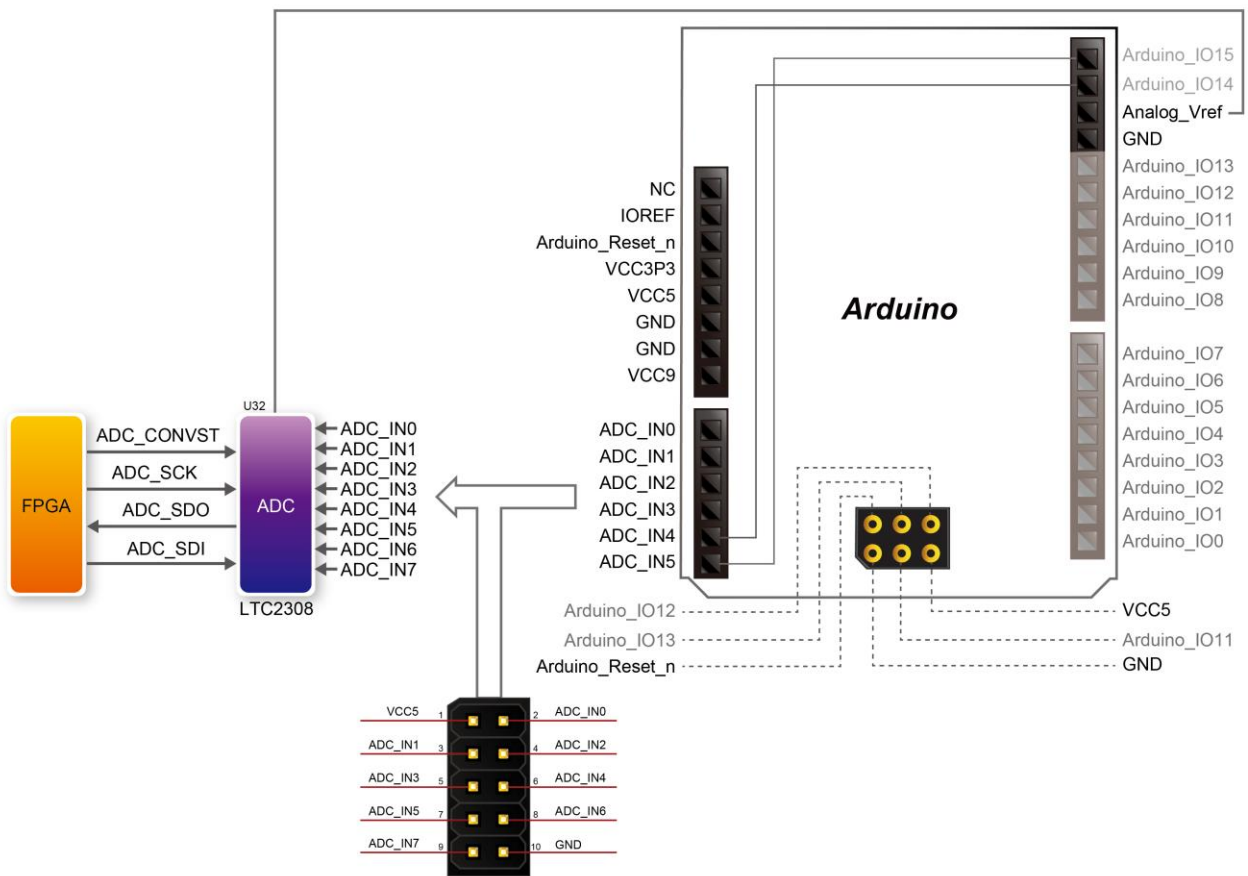

Figure 3-23 Connections between the FPGA, 2x5 header, and the A/D converter

Table 3-12 Pin Assignment of ADC

Signal Name	FPGA Pin No.	Description	I/O Standard
ADC_CONVST	PIN_U9	Conversion Start	3.3V
ADC_SCK	PIN_V10	Serial Data Clock	3.3V
ADC_SDI	PIN_AC4	Serial Data Input (FPGA to ADC)	3.3V
ADC_SDO	PIN_AD4	Serial Data Out (ADC to FPGA)	3.3V

3.6.5 HDMI TX Interface

The development board provides High Performance HDMI Transmitter via the Analog Devices ADV7513 which incorporates HDMI v1.4 features, including 3D video support, and 165 MHz supports all video formats up to 1080p and UXGA. The ADV7513 is controlled via a serial I2C bus interface, which is connected to pins on the Cyclone V SoC FPGA. A schematic diagram of the audio circuitry is shown in **Figure 3-24**. Detailed information on using the ADV7513 HDMI TX is available on the manufacturer’s website, or under the Datasheets\HDMI folder on the Kit System CD.

Table 3-13 lists the HDMI Interface pin assignments and signal names relative to the Cyclone V SoC device.

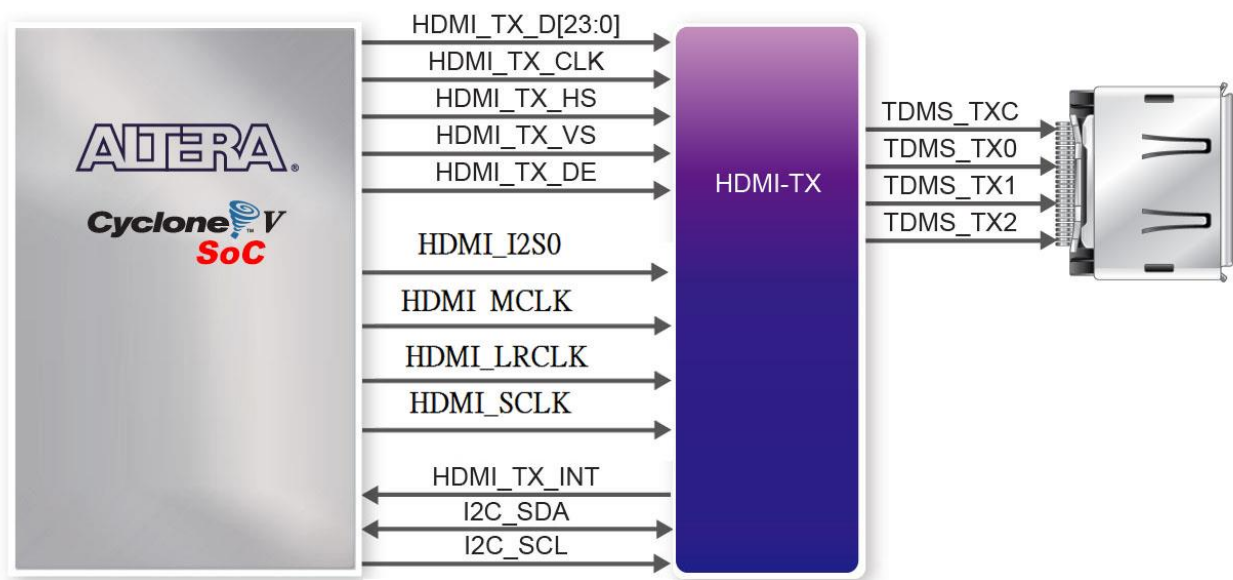

Figure 3-24 Connections between the Cyclone V SoC FPGA and HDMI Transmitter Chip

Table 3-13 HDMI Pin Assignments, Schematic Signal Names, and Functions

Signal Name	FPGA Pin No	Description	I/O Standard
HDMI_TX_D0	PIN_AD12	Video Data bus	3.3-V
HDMI_TX_D1	PIN_AE12	Video Data bus	3.3-V
HDMI_TX_D2	PIN_W8	Video Data bus	3.3-V
HDMI_TX_D3	PIN_Y8	Video Data bus	3.3-V
HDMI_TX_D4	PIN_AD11	Video Data bus	3.3-V
HDMI_TX_D5	PIN_AD10	Video Data bus	3.3-V
HDMI_TX_D6	PIN_AE11	Video Data bus	3.3-V
HDMI_TX_D7	PIN_Y5	Video Data bus	3.3-V
HDMI_TX_D8	PIN_AF10	Video Data bus	3.3-V
HDMI_TX_D9	PIN_Y4	Video Data bus	3.3-V
HDMI_TX_D10	PIN_AE9	Video Data bus	3.3-V
HDMI_TX_D11	PIN_AB4	Video Data bus	3.3-V
HDMI_TX_D12	PIN_AE7	Video Data bus	3.3-V
HDMI_TX_D13	PIN_AF6	Video Data bus	3.3-V
HDMI_TX_D14	PIN_AF8	Video Data bus	3.3-V
HDMI_TX_D15	PIN_AF5	Video Data bus	3.3-V
HDMI_TX_D16	PIN_AE4	Video Data bus	3.3-V
HDMI_TX_D17	PIN_AH2	Video Data bus	3.3-V
HDMI_TX_D18	PIN_AH4	Video Data bus	3.3-V
HDMI_TX_D19	PIN_AH5	Video Data bus	3.3-V
HDMI_TX_D20	PIN_AH6	Video Data bus	3.3-V
HDMI_TX_D21	PIN_AG6	Video Data bus	3.3-V
HDMI_TX_D22	PIN_AF9	Video Data bus	3.3-V
HDMI_TX_D23	PIN_AE8	Video Data bus	3.3-V
HDMI_TX_CLK	PIN_AG5	Video Clock	3.3-V
HDMI_TX_DE	PIN_AD19	Data Enable Signal for Digital Video.	3.3-V
HDMI_TX_HS	PIN_T8	Horizontal Synchronization	3.3-V
HDMI_TX_VS	PIN_V13	Vertical Synchronization	3.3-V
HDMI_TX_INT	PIN_AF11	Interrupt Signal	3.3-V
HDMI_I2S0	PIN_T13	I2S Channel 0 Audio Data Input	3.3-V
HDMI_MCLK	PIN_U11	Audio Reference Clock Input	3.3-V
HDMI_LRCLK	PIN_T11	Audio Left/Right Channel Signal Input	3.3-V
HDMI_SCLK	PIN_T12	I2S Audio Clock Input	3.3-V
I2C_SCL	PIN_U10	I2C Clock	3.3-V
I2C_SDA	PIN_AA4	I2C Data	3.3-V

3.7 Peripherals Connected to Hard Processor System (HPS)

This section introduces the interfaces connected to the HPS section of the Cyclone V SoC FPGA. Users can access these interfaces via the HPS processor.

3.7.1 User Push-buttons and LEDs

Similar to the FPGA, the HPS also has its set of switches, buttons, LEDs, and other interfaces connected exclusively. Users can control these interfaces to monitor the status of HPS.

Table 3-14 gives the pin assignment of all the LEDs, switches, and push-buttons.

Table 3-14 Pin Assignment of LEDs, Switches and Push-buttons

Signal Nam	FPGA Pin No	HPS GPIO	Register/bit	Function
HPS_KEY	PIN_J18	GPIO54	GPIO1[25]	I/O
HPS_LED	PIN_A20	GPIO53	GPIO1[24]	I/O

3.7.2 Gigabit Ethernet

The board supports Gigabit Ethernet transfer by an external Micrel KSZ9031RN PHY chip and HPS Ethernet MAC function. The KSZ9031RN chip with integrated 10/100/1000 Mbps Gigabit Ethernet transceiver also supports RGMII MAC interface. **Figure 3-23** shows the connections between the HPS, Gigabit Ethernet PHY, and RJ-45 connector.

The pin assignment associated to Gigabit Ethernet interface is listed in **Table 3-15**. More information about the KSZ9031RN PHY chip and its datasheet, as well as the application notes, which are available on the manufacturer's website.

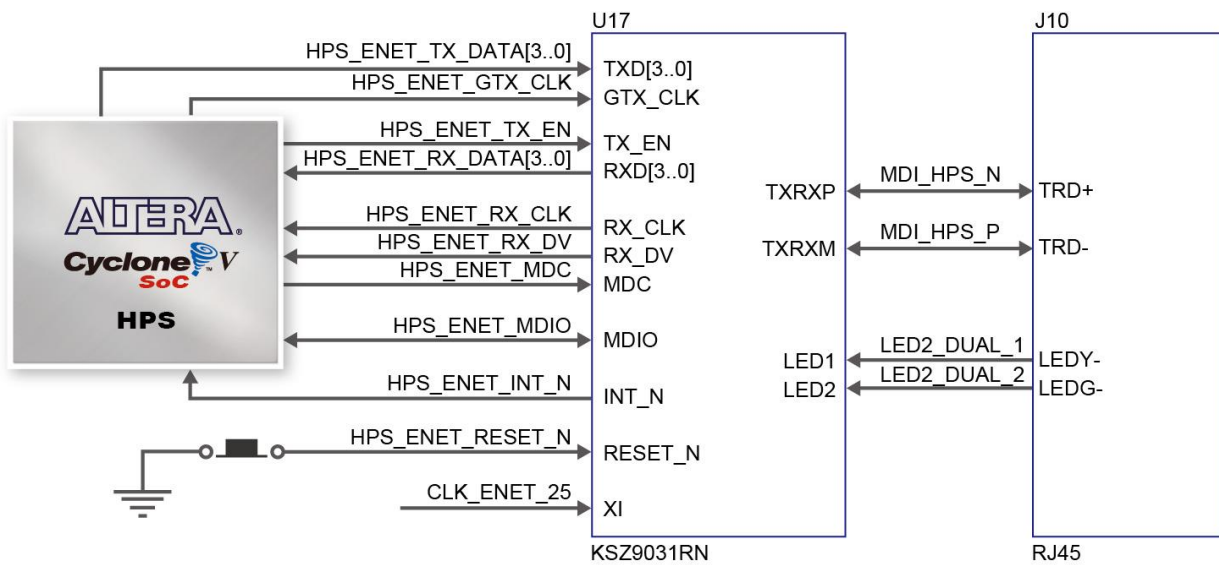

Figure 3-23 Connections between the HPS and Gigabit Ethernet

Table 3-15 Pin Assignment of Gigabit Ethernet PHY

Signal Name	FPGA Pin No	Description	I/O Standard
HPS_ENET_TX_EN	PIN_A12	GMII and MII transmit enable	3.3V
HPS_ENET_TX_DATA[0]	PIN_A16	MII transmit data[0]	3.3V
HPS_ENET_TX_DATA[1]	PIN_J14	MII transmit data[1]	3.3V
HPS_ENET_TX_DATA[2]	PIN_A15	MII transmit data[2]	3.3V
HPS_ENET_TX_DATA[3]	PIN_D17	MII transmit data[3]	3.3V
HPS_ENET_RX_DV	PIN_J13	GMII and MII receive data valid	3.3V
HPS_ENET_RX_DATA[0]	PIN_A14	GMII and MII receive data[0]	3.3V
HPS_ENET_RX_DATA[1]	PIN_A11	GMII and MII receive data[1]	3.3V
HPS_ENET_RX_DATA[2]	PIN_C15	GMII and MII receive data[2]	3.3V
HPS_ENET_RX_DATA[3]	PIN_A9	GMII and MII receive data[3]	3.3V
HPS_ENET_RX_CLK	PIN_J12	GMII and MII receive clock	3.3V
HPS_ENET_RESET_N	PIN_B4	Hardware Reset Signal	3.3V
HPS_ENET_MDIO	PIN_E16	Management Data	3.3V
HPS_ENET_MDC	PIN_A13	Management Data Clock Reference	3.3V
HPS_ENET_INT_N	PIN_B14	Interrupt Open Drain Output	3.3V
HPS_ENET_GTX_CLK	PIN_J15	GMII Transmit Clock	3.3V

There are two LEDs, green LED (LEDG) and yellow LED (LEDY), which represent the status of Ethernet PHY (KSZ9031RN). The LED control signals are connected to the LEDs on the RJ45 connector. The state and definition of LEDG and LEDY are listed in **Table 3-16**. For instance, the connection from board to Gigabit Ethernet is established once the LEDG lights on.

Table 3-16 State and Definition of LED Mode Pins

LED (State)		LED (Definition)		Link /Activity
LEDG	LEDY	LEDG	LEDY	
H	H	OFF	OFF	Link off
L	H	ON	OFF	1000 Link / No Activity
Toggle	H	Blinking	OFF	1000 Link / Activity (RX, TX)
H	L	OFF	ON	100 Link / No Activity
H	Toggle	OFF	Blinking	100 Link / Activity (RX, TX)
L	L	ON	ON	10 Link/ No Activity
Toggle	Toggle	Blinking	Blinking	Link / Activity (RX, TX)

3.7.3 UART

The board has one UART interface connected for communication with the HPS. This interface doesn't support HW flow control signals. The physical interface is implemented by UART-USB onboard bridge from a FT232R chip to the host with an USB Mini-B connector. More information about the chip is available on the manufacturer's website, or in the directory \Datasheets\UART_TO_USB of DE10-Nano system CD. **Figure 3-25** shows the connections between the HPS, FT232R chip, and the USB Mini-B connector. **Table 3-17** lists the pin assignment of UART interface connected to the HPS.

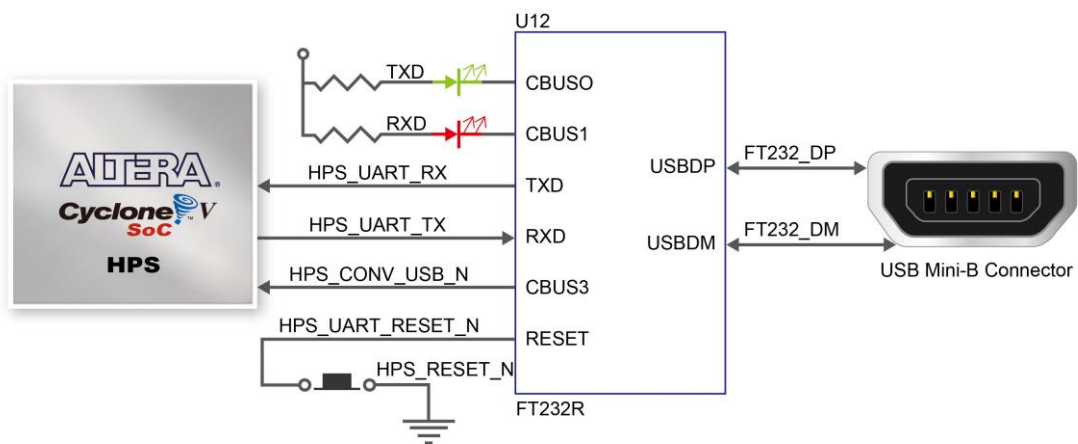

Figure 3-25 Connections between the HPS and FT232R Chip

Table 3-17 Pin Assignment of UART Interface

Signal Name	FPGA Pin No.	Description	I/O Standard
HPS_UART_RX	PIN_A22	HPS UART Receiver	3.3V
HPS_UART_TX	PIN_B21	HPS UART Transmitter	3.3V
HPS_CONV_USB_N	PIN_C6	Reserve	3.3V

3.7.4 DDR3 Memory

The board supports 1GB of DDR3 SDRAM comprising of two x16 bit DDR3 devices on HPS side. The signals are connected to the dedicated Hard Memory Controller for HPS I/O banks and the target speed is 400 MHz. **Figure 3-26** shows the connections between the DDR3 and Cyclone V SoC FPGA. **Table 3-18** lists the pin assignment of DDR3 and its description with I/O standard.

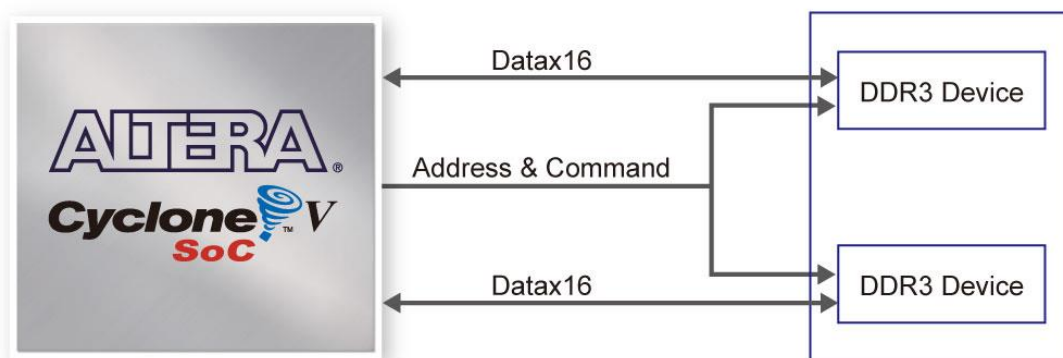

Figure 3-26 Connections between FPGA and DDR3

Table 3-18 Pin Assignment of DDR3 Memory

Signal Name	FPGA Pin No	Description	I/O Standard
HPS_DDR3_A[0]	PIN_C28	HPS DDR3 Address[0]	SSTL-15 Class I
HPS_DDR3_A[1]	PIN_B28	HPS DDR3 Address[1]	SSTL-15 Class I
HPS_DDR3_A[2]	PIN_E26	HPS DDR3 Address[2]	SSTL-15 Class I
HPS_DDR3_A[3]	PIN_D26	HPS DDR3 Address[3]	SSTL-15 Class I
HPS_DDR3_A[4]	PIN_J21	HPS DDR3 Address[4]	SSTL-15 Class I
HPS_DDR3_A[5]	PIN_J20	HPS DDR3 Address[5]	SSTL-15 Class I
HPS_DDR3_A[6]	PIN_C26	HPS DDR3 Address[6]	SSTL-15 Class I
HPS_DDR3_A[7]	PIN_B26	HPS DDR3 Address[7]	SSTL-15 Class I
HPS_DDR3_A[8]	PIN_F26	HPS DDR3 Address[8]	SSTL-15 Class I
HPS_DDR3_A[9]	PIN_F25	HPS DDR3 Address[9]	SSTL-15 Class I
HPS_DDR3_A[10]	PIN_A24	HPS DDR3 Address[10]	SSTL-15 Class I
HPS_DDR3_A[11]	PIN_B24	HPS DDR3 Address[11]	SSTL-15 Class I
HPS_DDR3_A[12]	PIN_D24	HPS DDR3 Address[12]	SSTL-15 Class I
HPS_DDR3_A[13]	PIN_C24	HPS DDR3 Address[13]	SSTL-15 Class I
HPS_DDR3_A[14]	PIN_G23	HPS DDR3 Address[14]	SSTL-15 Class I
HPS_DDR3_BA[0]	PIN_A27	HPS DDR3 Bank Address[0]	SSTL-15 Class I
HPS_DDR3_BA[1]	PIN_H25	HPS DDR3 Bank Address[1]	SSTL-15 Class I

HPS_DDR3_BA[2]	PIN_G25	HPS DDR3 Bank Address[2]	SSTL-15 Class I
HPS_DDR3_CAS_n	PIN_A26	DDR3 Column Address Strobe	SSTL-15 Class I
HPS_DDR3_CKE	PIN_L28	HPS DDR3 Clock Enable	SSTL-15 Class I
HPS_DDR3_CK_n	PIN_N20	HPS DDR3 Clock	Differential 1.5-V SSTL Class I
HPS_DDR3_CK_p	PIN_N21	HPS DDR3 Clock p	Differential 1.5-V SSTL Class I
HPS_DDR3_CS_n	PIN_L21	HPS DDR3 Chip Select	SSTL-15 Class I
HPS_DDR3_DM[0]	PIN_G28	HPS DDR3 Data Mask[0]	SSTL-15 Class I
HPS_DDR3_DM[1]	PIN_P28	HPS DDR3 Data Mask[1]	SSTL-15 Class I
HPS_DDR3_DM[2]	PIN_W28	HPS DDR3 Data Mask[2]	SSTL-15 Class I
HPS_DDR3_DM[3]	PIN_AB28	HPS DDR3 Data Mask[3]	SSTL-15 Class I
HPS_DDR3_DQ[0]	PIN_J25	HPS DDR3 Data[0]	SSTL-15 Class I
HPS_DDR3_DQ[1]	PIN_J24	HPS DDR3 Data[1]	SSTL-15 Class I
HPS_DDR3_DQ[2]	PIN_E28	HPS DDR3 Data[2]	SSTL-15 Class I
HPS_DDR3_DQ[3]	PIN_D27	HPS DDR3 Data[3]	SSTL-15 Class I
HPS_DDR3_DQ[4]	PIN_J26	HPS DDR3 Data[4]	SSTL-15 Class I
HPS_DDR3_DQ[5]	PIN_K26	HPS DDR3 Data[5]	SSTL-15 Class I
HPS_DDR3_DQ[6]	PIN_G27	HPS DDR3 Data[6]	SSTL-15 Class I
HPS_DDR3_DQ[7]	PIN_F28	HPS DDR3 Data[7]	SSTL-15 Class I
HPS_DDR3_DQ[8]	PIN_K25	HPS DDR3 Data[8]	SSTL-15 Class I
HPS_DDR3_DQ[9]	PIN_L25	HPS DDR3 Data[9]	SSTL-15 Class I
HPS_DDR3_DQ[10]	PIN_J27	HPS DDR3 Data[10]	SSTL-15 Class I
HPS_DDR3_DQ[11]	PIN_J28	HPS DDR3 Data[11]	SSTL-15 Class I
HPS_DDR3_DQ[12]	PIN_M27	HPS DDR3 Data[12]	SSTL-15 Class I
HPS_DDR3_DQ[13]	PIN_M26	HPS DDR3 Data[13]	SSTL-15 Class I
HPS_DDR3_DQ[14]	PIN_M28	HPS DDR3 Data[14]	SSTL-15 Class I
HPS_DDR3_DQ[15]	PIN_N28	HPS DDR3 Data[15]	SSTL-15 Class I
HPS_DDR3_DQ[16]	PIN_N24	HPS DDR3 Data[16]	SSTL-15 Class I
HPS_DDR3_DQ[17]	PIN_N25	HPS DDR3 Data[17]	SSTL-15 Class I
HPS_DDR3_DQ[18]	PIN_T28	HPS DDR3 Data[18]	SSTL-15 Class I
HPS_DDR3_DQ[19]	PIN_U28	HPS DDR3 Data[19]	SSTL-15 Class I
HPS_DDR3_DQ[20]	PIN_N26	HPS DDR3 Data[20]	SSTL-15 Class I
HPS_DDR3_DQ[21]	PIN_N27	HPS DDR3 Data[21]	SSTL-15 Class I
HPS_DDR3_DQ[22]	PIN_R27	HPS DDR3 Data[22]	SSTL-15 Class I
HPS_DDR3_DQ[23]	PIN_V27	HPS DDR3 Data[23]	SSTL-15 Class I
HPS_DDR3_DQ[24]	PIN_R26	HPS DDR3 Data[24]	SSTL-15 Class I
HPS_DDR3_DQ[25]	PIN_R25	HPS DDR3 Data[25]	SSTL-15 Class I
HPS_DDR3_DQ[26]	PIN_AA28	HPS DDR3 Data[26]	SSTL-15 Class I
HPS_DDR3_DQ[27]	PIN_W26	HPS DDR3 Data[27]	SSTL-15 Class I
HPS_DDR3_DQ[28]	PIN_R24	HPS DDR3 Data[28]	SSTL-15 Class I
HPS_DDR3_DQ[29]	PIN_T24	HPS DDR3 Data[29]	SSTL-15 Class I
HPS_DDR3_DQ[30]	PIN_Y27	HPS DDR3 Data[30]	SSTL-15 Class I

HPS_DDR3_DQ[31]	PIN_AA27	HPS DDR3 Data[31]	SSTL-15 Class I
HPS_DDR3_DQS_n[0]	PIN_R16	HPS DDR3 Data Strobe n[0]	Differential 1.5-V SSTL Class I
HPS_DDR3_DQS_n[1]	PIN_R18	HPS DDR3 Data Strobe n[1]	Differential 1.5-V SSTL Class I
HPS_DDR3_DQS_n[2]	PIN_T18	HPS DDR3 Data Strobe n[2]	Differential 1.5-V SSTL Class I
HPS_DDR3_DQS_n[3]	PIN_T20	HPS DDR3 Data Strobe n[3]	Differential 1.5-V SSTL Class I
HPS_DDR3_DQS_p[0]	PIN_R17	HPS DDR3 Data Strobe p[0]	Differential 1.5-V SSTL Class I
HPS_DDR3_DQS_p[1]	PIN_R19	HPS DDR3 Data Strobe p[1]	Differential 1.5-V SSTL Class I
HPS_DDR3_DQS_p[2]	PIN_T19	HPS DDR3 Data Strobe p[2]	Differential 1.5-V SSTL Class I
HPS_DDR3_DQS_p[3]	PIN_U19	HPS DDR3 Data Strobe p[3]	Differential 1.5-V SSTL Class I
HPS_DDR3_ODT	PIN_D28	HPS DDR3 On-die Termination	SSTL-15 Class I
HPS_DDR3_RAS_n	PIN_A25	DDR3 Row Address Strobe	SSTL-15 Class I
HPS_DDR3_RESET_n	PIN_V28	HPS DDR3 Reset	SSTL-15 Class I
HPS_DDR3_WE_n	PIN_E25	HPS DDR3 Write Enable	SSTL-15 Class I
HPS_DDR3_RZQ	PIN_D25	For output drive calibration	1.5V

3.7.5 Micro SD Card Socket

The board supports Micro SD card interface with x4 data lines. It serves not only an external storage for the HPS, but also an alternative boot option for DE10-Nano board. **Figure 3-27** shows signals connected between the HPS and Micro SD card socket.

Table 3-19 lists the pin assignment of Micro SD card socket to the HPS.

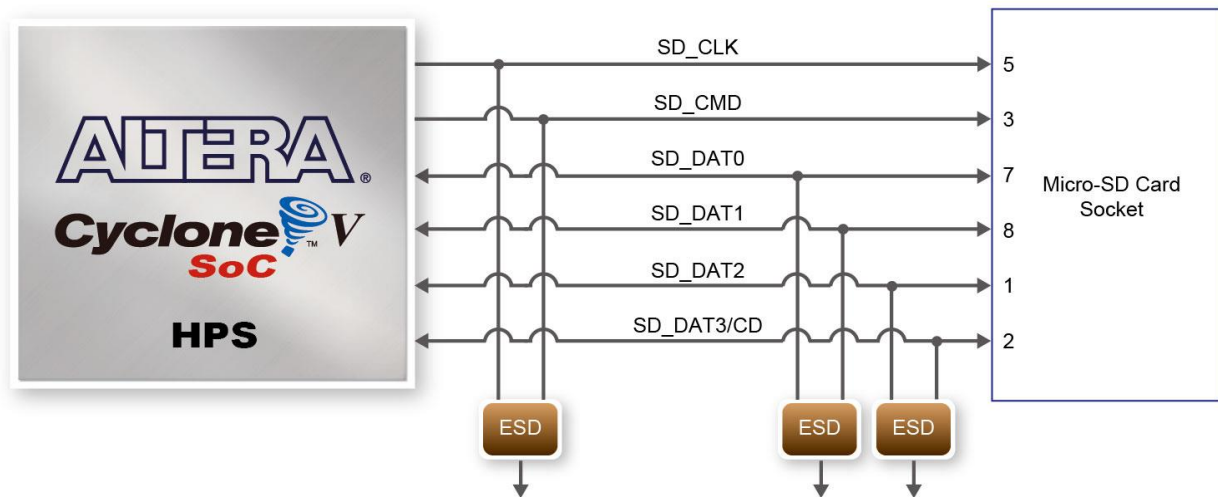

Figure 3-27 Connections between the FPGA and SD card socket

Table 3-19 Pin Assignment of Micro SD Card Socket

Signal Name	FPGA Pin No	Description	I/O Standard
HPS_SD_CLK	PIN_B8	HPS SD Clock	3.3V
HPS_SD_CMD	PIN_D14	HPS SD Command Line	3.3V
HPS_SD_DATA[0]	PIN_C13	HPS SD Data[0]	3.3V
HPS_SD_DATA[1]	PIN_B6	HPS SD Data[1]	3.3V
HPS_SD_DATA[2]	PIN_B11	HPS SD Data[2]	3.3V
HPS_SD_DATA[3]	PIN_B9	HPS SD Data[3]	3.3V

3.7.6 USB 2.0 OTG PHY

The board provides USB interfaces using the SMSC USB3300 controller. A SMSC USB3300 device in a 32-pin QFN package device is used to interface to a single Type AB Micro-USB connector. This device supports UTMI+ Low Pin Interface (ULPI) to communicate to USB 2.0 controller in HPS. As defined by OTG mode, the PHY can operate in Host or Device modes. When operating in Host mode, the interface will supply the power to the device through the Micro-USB interface. **Figure 3-28** shows the connections of USB PTG PHY to the HPS. **Table 3-20** lists the pin assignment of USB OTG PHY to the HPS.

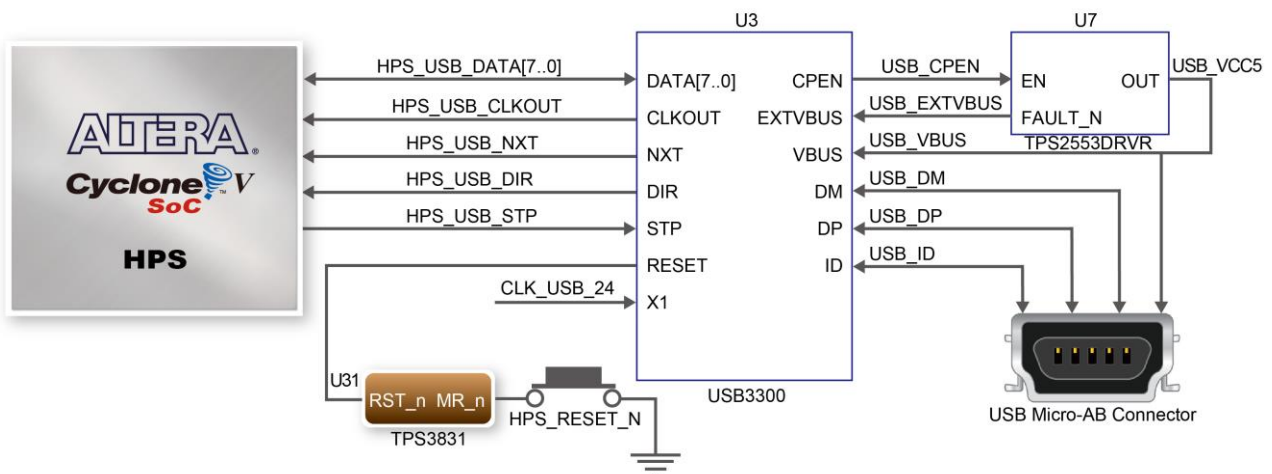

Figure 3-28 Connections between the HPS and USB OTG PHY

Table 3-20 Pin Assignment of USB OTG PHY

Signal Name	FPGA Pin No.	Description	I/O Standard
HPS_USB_CLKOUT	PIN_G4	60MHz Reference Clock Output	3.3V
HPS_USB_DATA[0]	PIN_C10	HPS USB_DATA[0]	3.3V
HPS_USB_DATA[1]	PIN_F5	HPS USB_DATA[1]	3.3V
HPS_USB_DATA[2]	PIN_C9	HPS USB_DATA[2]	3.3V
HPS_USB_DATA[3]	PIN_C4	HPS USB_DATA[3]	3.3V
HPS_USB_DATA[4]	PIN_C8	HPS USB_DATA[4]	3.3V
HPS_USB_DATA[5]	PIN_D4	HPS USB_DATA[5]	3.3V
HPS_USB_DATA[6]	PIN_C7	HPS USB_DATA[6]	3.3V
HPS_USB_DATA[7]	PIN_F4	HPS USB_DATA[7]	3.3V
HPS_USB_DIR	PIN_E5	Direction of the Data Bus	3.3V
HPS_USB_NXT	PIN_D5	Throttle the Data	3.3V
HPS_USB_RESET	PIN_H12	HPS USB PHY Reset	3.3V
HPS_USB_STP	PIN_C5	Stop Data Stream on the Bus	3.3V

3.7.7 G-sensor

The board comes with a digital accelerometer sensor module (ADXL345), commonly known as G-sensor. This G-sensor is a small, thin, ultralow power assumption 3-axis accelerometer with high-resolution measurement. Digitalized output is formatted as 16-bit in two's complement and can be accessed through I2C interface. The I2C address of G-sensor is 0xA6/0xA7. More information about this chip can be found in its datasheet, which is available on manufacturer's website or in the directory \Datasheet\G-Sensor folder of DE10-Nano system CD. **Figure 3-29** shows the connections between the HPS and G-sensor. **Table 3-21** lists the pin assignment of G-sensor to the HPS.

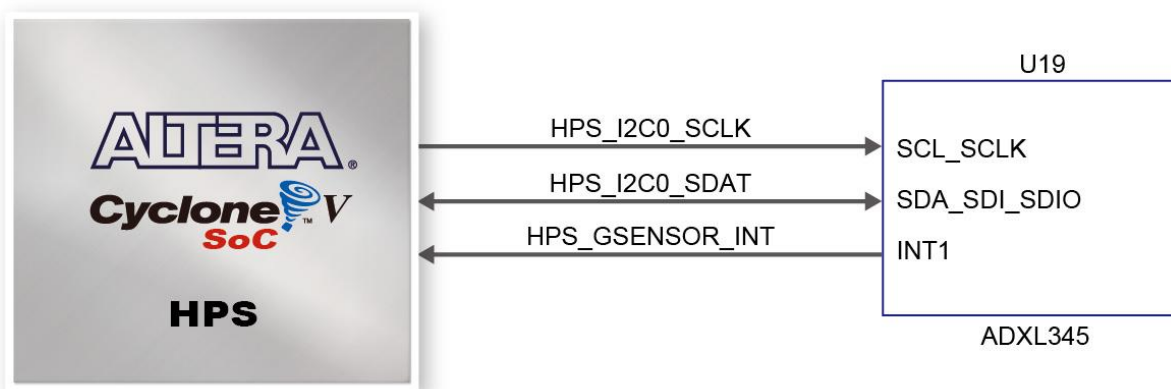

Figure 3-29 Connections between Cyclone V SoC FPGA and G-Sensor

Table 3-21 Pin Assignment of G-sensor

Signal Name	FPGA Pin No.	Description	I/O Standard
HPS_GSENSOR_INT	PIN_A17	HPS GSENSOR Interrupt Output	3.3V
HPS_I2C0_SCLK	PIN_C18	HPS I2C0 Clock	3.3V
HPS_I2C0_SDAT	PIN_A19	HPS I2C0 Data	3.3V

3.7.8 LTC Connector

The board has a 14-pin header, which is originally used to communicate with various daughter cards from Linear Technology. It is connected to the SPI Master and I2C ports of HPS. The communication with these two protocols is bi-directional. The 14-pin header can also be used for GPIO, SPI, or I2C based communication with the HPS. Connections between the HPS and LTC connector are shown in **Figure 3-30**, and the pin assignment of LTC connector is listed in **Table 3-22**.

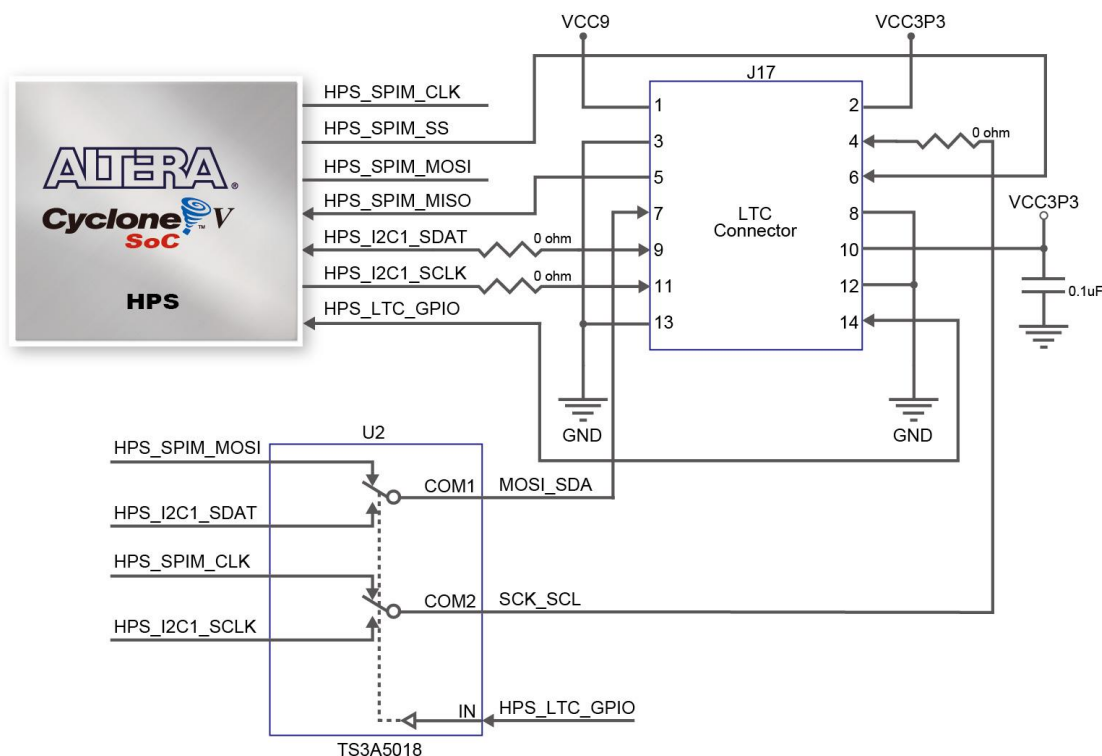

Figure 3-30 Connections between the HPS and LTC connector

Table 3-22 Pin Assignment of LTC Connector

Signal Name	FPGA Pin No.	Description	I/O Standard
HPS_LTC_GPIO	PIN_H13	HPS LTC GPIO	3.3V
HPS_I2C1_SCLK	PIN_K18	HPS I2C1 Clock	3.3V
HPS_I2C1_SDAT	PIN_A21	HPS I2C1 Data	3.3V
HPS_SPIM_CLK	PIN_C19	SPI Clock	3.3V
HPS_SPIM_MISO	PIN_B19	SPI Master Input/Slave Output	3.3V
HPS_SPIM_MOSI	PIN_B16	SPI Master Output /Slave Input	3.3V
HPS_SPIM_SS	PIN_C16	SPI Slave Select	3.3V

Chapter 4

DE10-Nano System Builder

This chapter describes how users can create a custom design project with the tool named DE10-Nano System Builder.

4.1 Introduction

The DE10-Nano System Builder is a Windows-based utility. It is designed to help users create a Quartus II project for DE10-Nano within minutes. The generated Quartus II project files include:

- Quartus II project file (.qpf)
- Quartus II setting file (.qsf)
- Top-level design file (.v)
- Synopsis design constraints file (.sdc)
- Pin assignment document (.htm)

The above files generated by the DE10-Nano System Builder can also prevent occurrence of situations that are prone to compilation error when users manually edit the top-level design file or place pin assignment. The common mistakes that users encounter are:

- Board is damaged due to incorrect bank voltage setting or pin assignment.
- Board is malfunctioned because of wrong device chosen, declaration of pin location or direction is incorrect or forgotten.
- Performance degradation due to improper pin assignment.

4.2 Design Flow

This section provides an introduction to the design flow of building a Quartus II project for DE10-Nano under the DE10-Nano System Builder. The design flow is illustrated in **Figure 4-1**.

The DE10-Nano System Builder will generate two major files, a top-level design file (.v) and a Quartus II setting file (.qsf) after users launch the DE10-Nano System Builder and create a new project according to their design requirements.

The top-level design file contains a top-level Verilog HDL wrapper for users to add their own design/logic. The Quartus II setting file contains information such as FPGA device type, top-level pin assignment, and the I/O standard for each user-defined I/O pin.

Finally, the Quartus II programmer is used to download .sof file to the development board via JTAG interface.

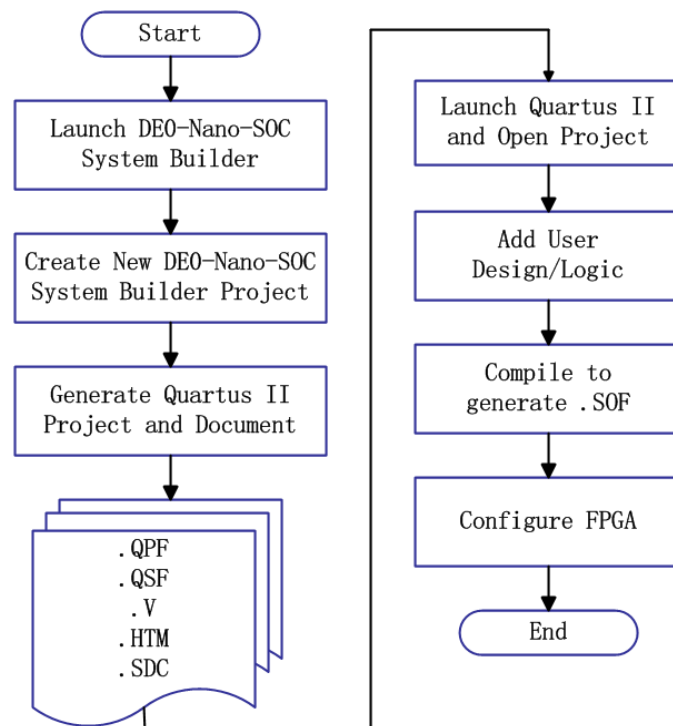

Figure 4-1 Design flow of building a project from the beginning to the end

4.3 Using DE10-Nano System Builder

This section provides the procedures in details on how to use the DE10-Nano System Builder.

■ Install and Launch the DE10-Nano System Builder

The DE10-Nano System Builder is located in the directory: “Tools\SystemBuilder” of the DE10-Nano System CD. Users can copy the entire folder to a host computer without installing the utility. A window will pop up, as shown in **Figure 4-2**, after executing the DE10-Nano SystemBuilder.exe on the host computer.

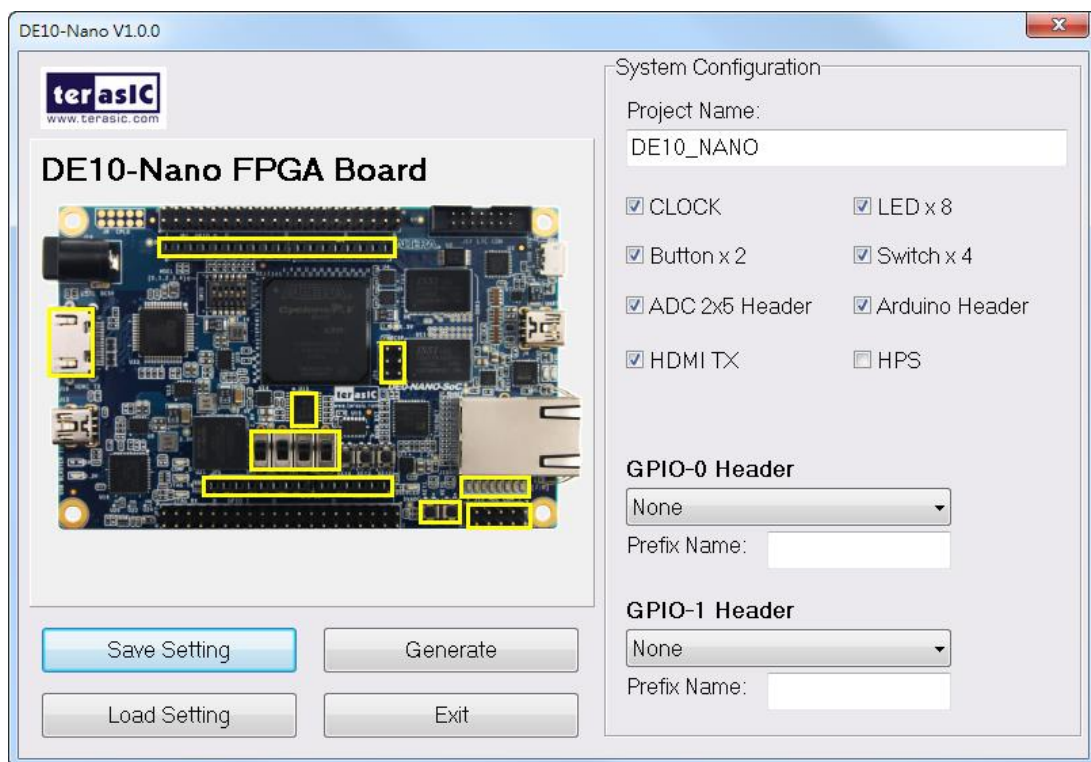

Figure 4-2 The GUI of DE10-Nano System Builder

■ Enter Project Name

Enter the project name in the circled area, as shown in **Figure 4-3**.

The project name typed in will be assigned automatically as the name of your top-level design entity.

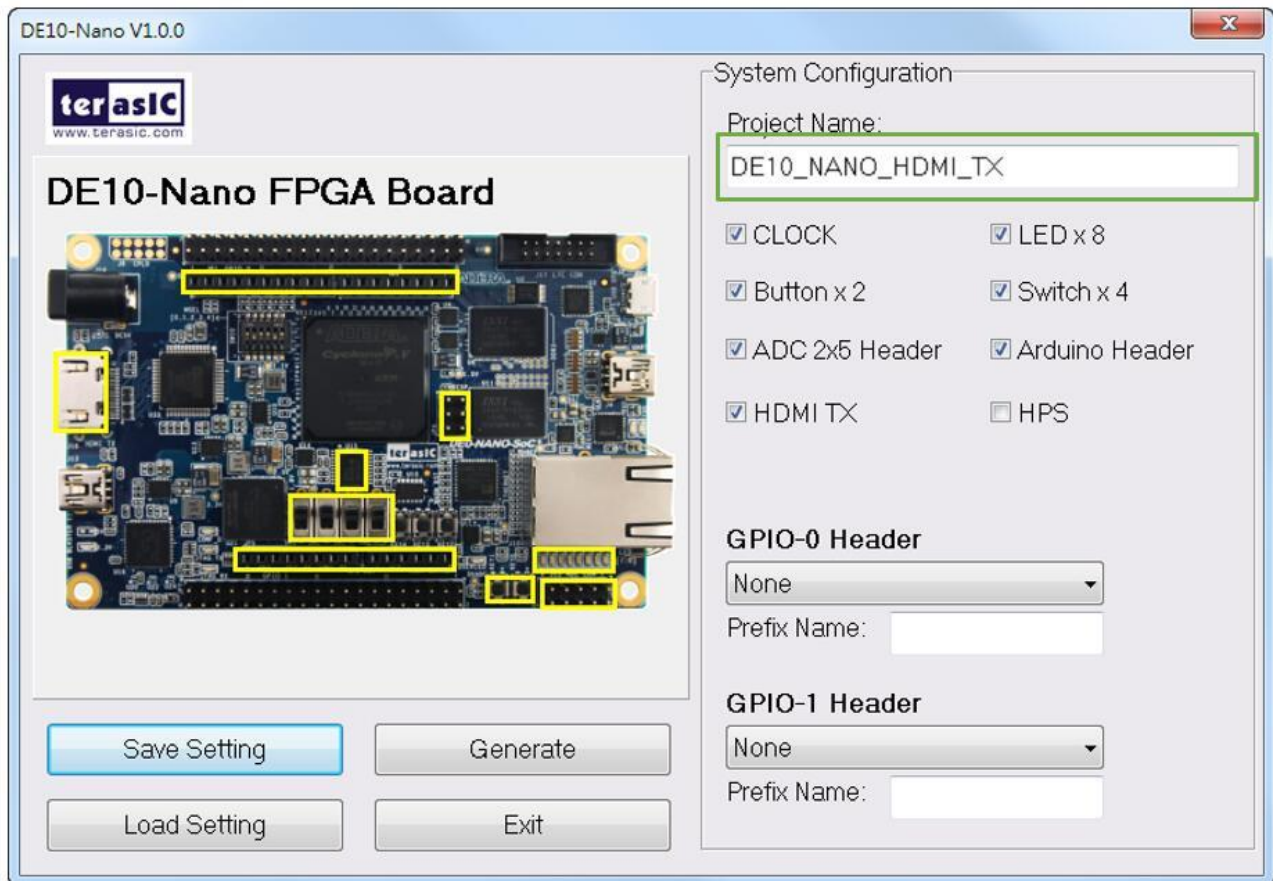

Figure 4-3 Enter the project name

■ System Configuration

Users are given the flexibility in the System Configuration to include their choice of components in the project, as shown in **Figure 4-4**. Each component onboard is listed and users can enable or disable one or more components at will. If a component is enabled, the DE10-Nano System Builder will automatically generate its associated pin assignment, including the pin name, pin location, pin direction, and I/O standard.

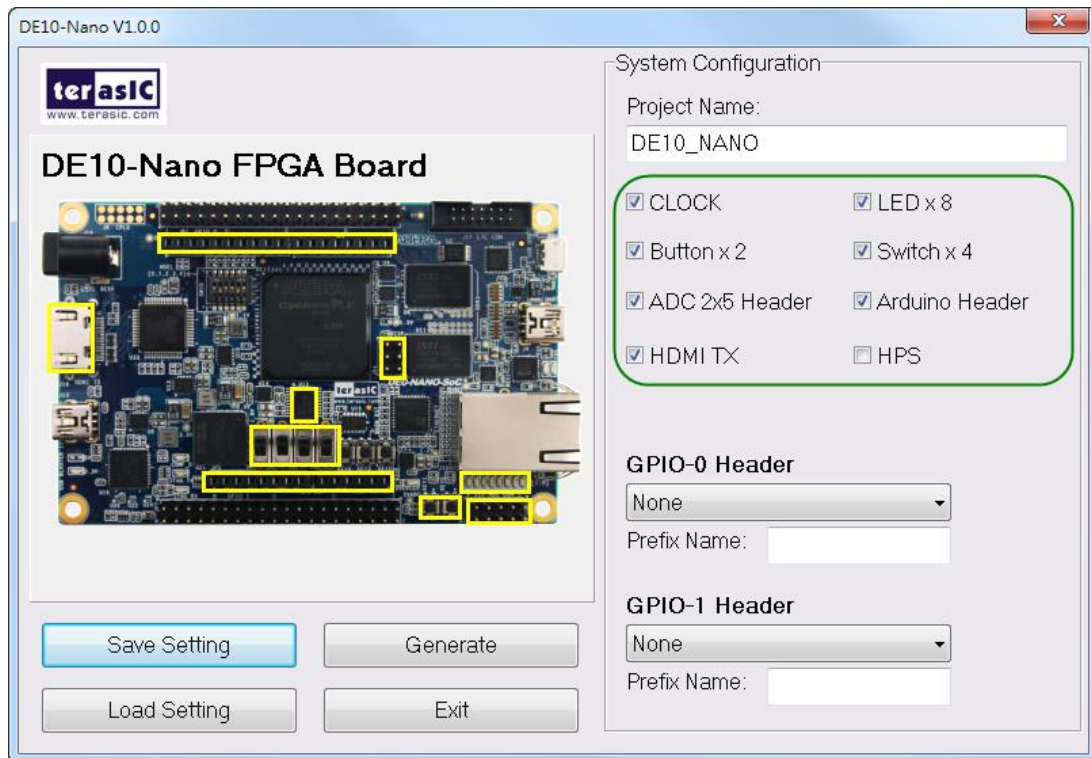

Figure 4-4 System configuration group

■ GPIO Expansion

If users connect any Terasic GPIO-based daughter card to the GPIO connector(s) on DE10-Nano, the DE10-Nano System Builder can generate a project that include the corresponding module, as shown in **Figure 4-5**. It will also generate the associated pin assignment automatically, including pin name, pin location, pin direction, and I/O standard.

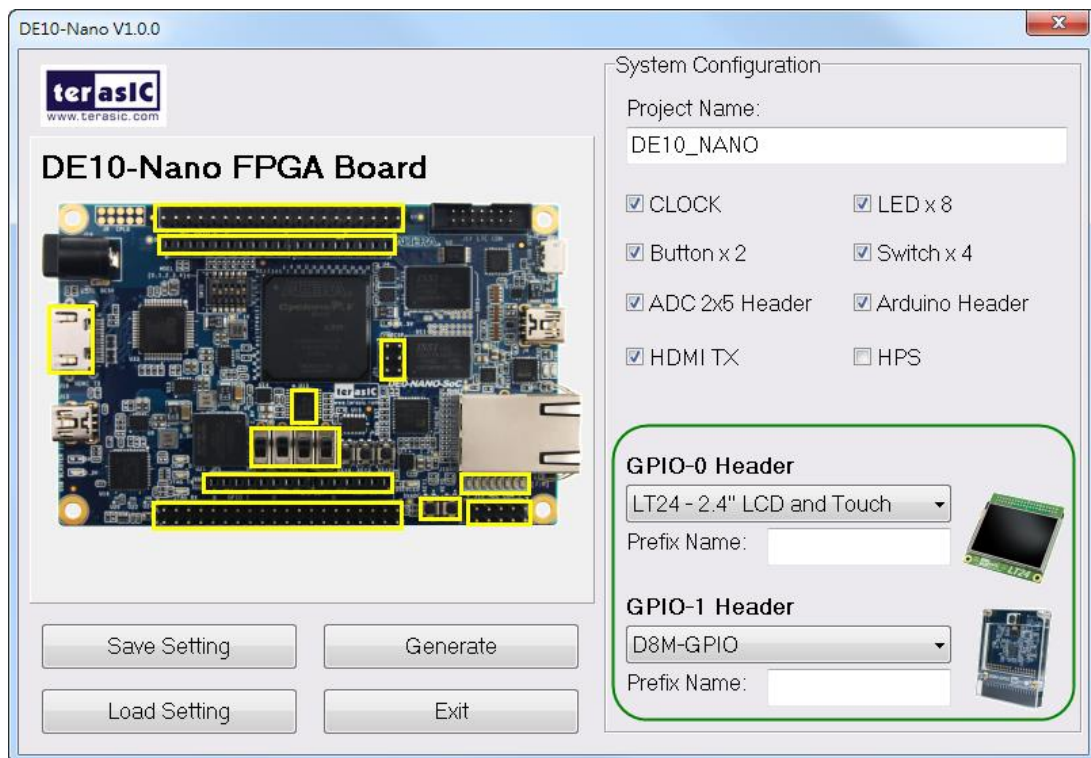

Figure 4-5 GPIO expansion group

The “Prefix Name” is an optional feature that denote the pin name of the daughter card assigned in your design. Users may leave this field blank.

■ Project Setting Management

The DE10-Nano System Builder also provides the option to load a setting or save users' current board configuration in .cfg file, as shown in **Figure 4-6**.

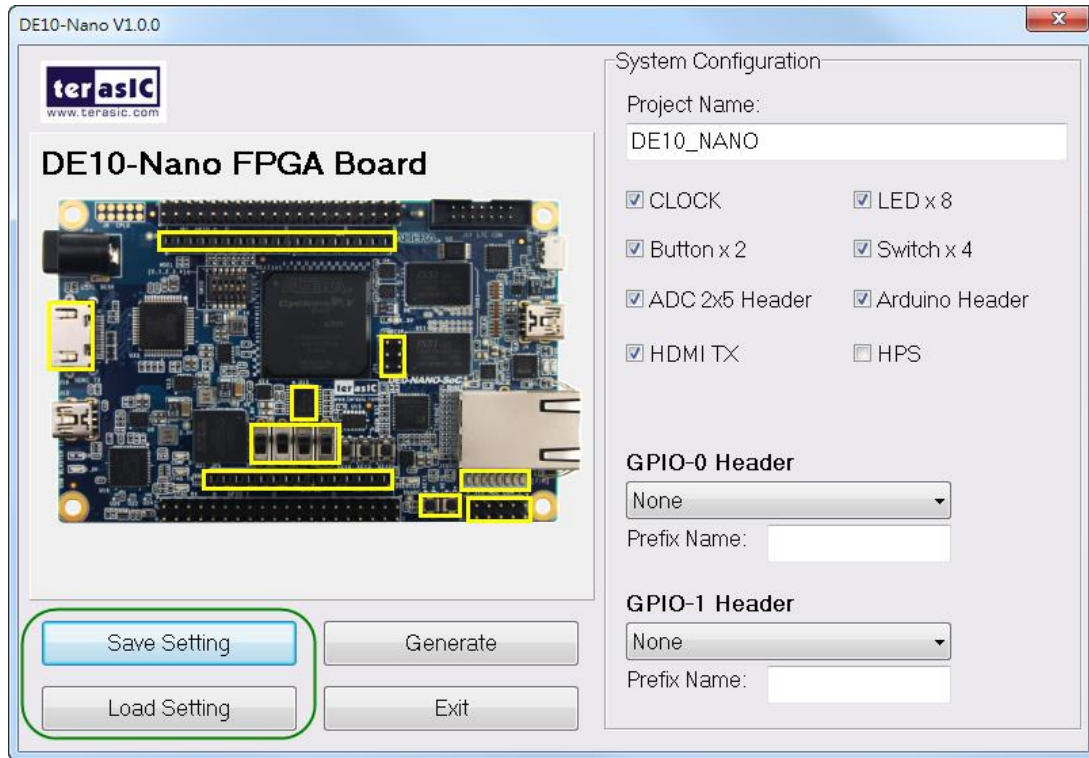

Figure 4-6 Project Settings

■ Project Generation

When users press the *Generate* button, the DE10-Nano System Builder will generate the corresponding Quartus II files and documents, as listed in **Table 4-1**:

Table 4-1 Files generated by the DE10-Nano System Builder

No.	Filename	Description
1	<Project name>.v	Top level Verilog HDL file for Quartus II
2	<Project name>.qpf	Quartus II Project File
3	<Project name>.qsf	Quartus II Setting File
4	<Project name>.sdc	Synopsis Design Constraints file for Quartus II
5	<Project name>.htm	Pin Assignment Document

Users can add custom logic into the project in Quartus II and compile the project to generate the SRAM Object File (.sof).

Chapter 5

Examples For FPGA

This chapter provides examples of advanced designs implemented by RTL or Qsys on the DE10-Nano board. These reference designs cover the features of peripherals connected to the FPGA, such as A/D Converter. All the associated files can be found in the directory \Demonstrations\FPGA of DE10-Nano System CD.

■ Installation of Demonstrations

Install the demonstrations on your computer:

Copy the folder Demonstrations to a local directory of your choice. It is important to make sure the path to your local directory contains NO space. Otherwise it will lead to error in Nios II.

Note Quartus II v16.0 or later is required for all DE10-Nano demonstrations to support Cyclone V SoC device.

5.1 DE10-Nano Factory Configuration

The DE10-Nano board has a default configuration bit-stream pre-programmed, which demonstrates some of the basic features on board. The setup required for this demonstration and the location of its files are shown below.

■ Demonstration Setup, File Locations, and Instructions

- Project directory: \Default
- Bitstream used: DE10_NANO_Default.sof or DE10_NANO_Default.jic
- Demo batch file : \Default\demo_batch\test.bat
- Power on the DE10-Nano board with the USB cable connected to the USB-Blaster II port. If necessary (that is, if the default factory configuration is not currently stored in the EPCS device), download the bit stream to the board via JTAG interface.
- You should now be able to observe the LEDs are blinking.

- For the ease of execution, a demo_batch folder is provided in the project. It is able to not only load the bit stream into the FPGA in command line, but also program or erase .jic file to the EPCS by executing the “test.bat” file shown in **Figure 5-1**
- If users want to program a new design into the EPCS device, the easiest method is to copy the new .sof file into the demo_batch folder and execute the “test.bat”. Option “2” will convert the .sof to .jic and option “3” will program .jic file into the EPCS device.

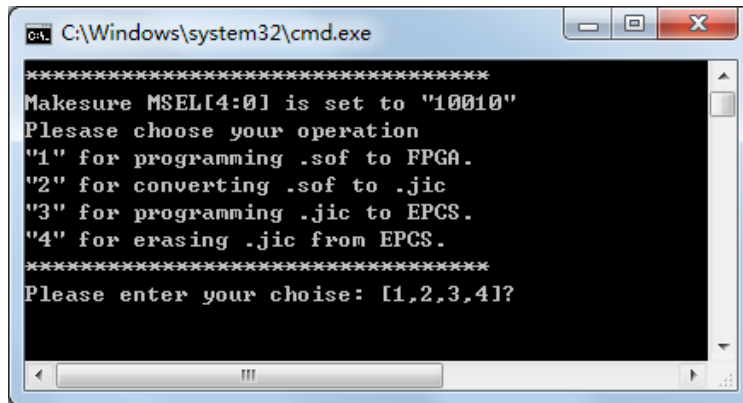

Figure 5-1 Command line of the batch file to program the FPGA and EPCS device

5.2 ADC Reading

This demonstration illustrates steps to evaluate the performance of the 8-channel 12-bit A/D Converter LTC2308. The DC 5.0V on the 2x5 header is used to drive the analog signals by a trimmer potentiometer. The voltage can be adjusted within the range between 0 and 4.096V. The 12-bit voltage measurement is displayed on the NIOS II console.

Figure 5-2 shows the block diagram of this demonstration.

If the input voltage is -2.0V ~ 2.0V, a pre-scale circuit can be used to adjust it to 0 ~ 4V.

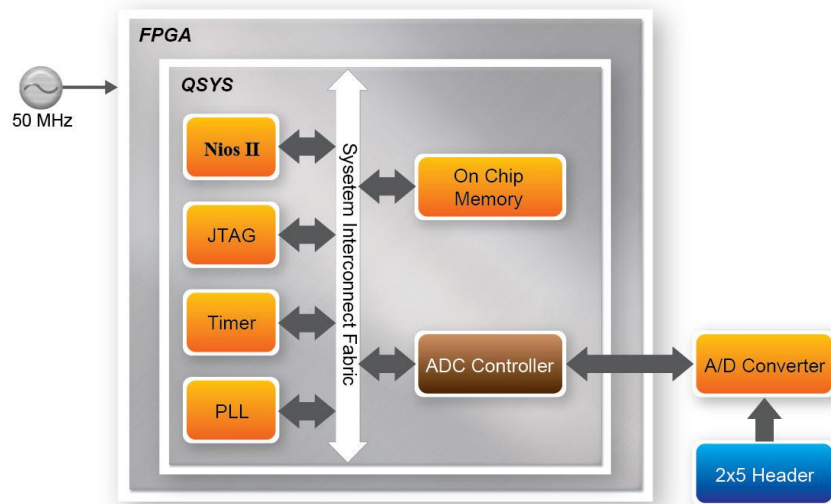

Figure 5-2 Block diagram of ADC reading

Figure 5-3 depicts the pin arrangement of the 2x5 header. This header is the input source of ADC convertor in this demonstration. Users can connect a trimmer to the specified ADC channel (ADC_IN0 ~ ADC_IN7) that provides voltage to the ADC convert. The FPGA will read the associated register in the convertor via serial interface and translates it to voltage value to be displayed on the Nios II console.

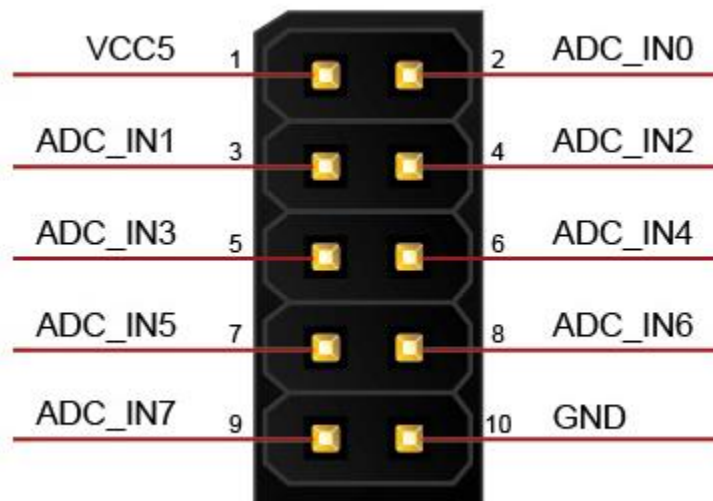

Figure 5-3 Pin distribution of the 2x5 Header for the ADC

■ System Requirements

The following items are required for this demonstration.

- DE10-Nano board x1
- Trimmer Potentiometer x1
- Wire Strip x3

■ Demonstration File Locations

- Hardware project directory: \ADC
- Bitstream used: DE10_NANO_ADC.sof
- Software project directory: \ADC\software
- Nios II program: DE10_NANO_ADC.elf
- Demo batch file : \ADC\demo_batch\test.bat

■ Demonstration Setup and Instructions

- Connect the trimmer to corresponding ADC channel on the 2x5 header, as shown in **Figure 5-4**, as well as the +5V and GND signals. The setup shown above is connected to ADC channel 0.
- Execute the demo batch file **“test.bat”** to load the bitstream and software execution file to the FPGA.
- The Nios II console will display the voltage of the specified channel voltage result information

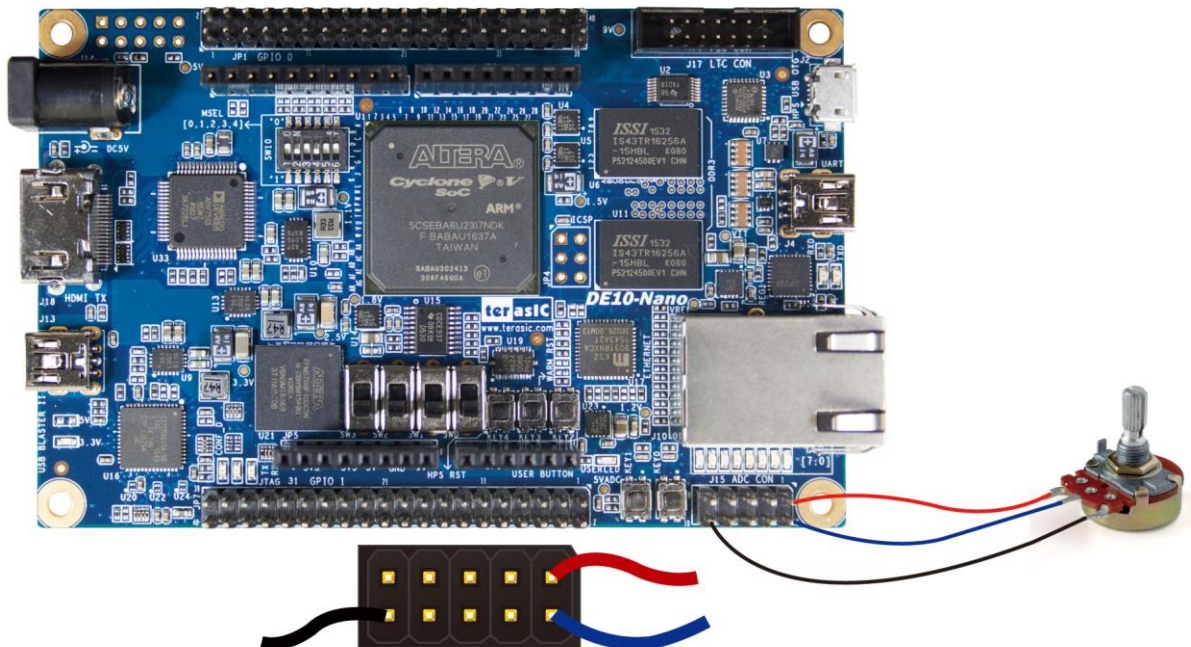

Figure 5-4 Hardware setup for the ADC reading demonstration

5.3 HDMI TX

This section gives instructions to program the HDMI transmitter to generate video pattern and audio source. The entire reference is composed into three parts: video design, audio design, and I2C design. A set of built-in video patterns and audio serial data will be sent to the HDMI transmitter to drive the HDMI display with speaker. Users can hear the beeping sound from the speaker when SW0 is set to 1 on the DE10-Nano board. The resolution can be switched by pressing KEY1.

■ System Block Diagram

Figure 5-5 shows the system block diagram of this reference design. The HDMI Transmitter is configured via I2C interface by I2C Controller and I2C HDMI Config. It is necessary to configure the HDMI transmitter according to the desired settings.

An interrupt mechanism called Hot Plug Detect (HPD) is implemented in I2C HDMI config. to re-configure HDMI transmitter when HPD interrupt occurs.

The Video Patter Generator was designed to send video patter to HDMI transmitter. Its resolution can be changed by pressing KEY1. There must be a PLL Reconfig. To change the PLL dynamically to support different resolutions. The Audio PLL and Audio Generator were designed to send audio pattern to HDMI transmitter. The audio is transmitted via I2S interface in this demo. Users can choose to enable audio generator or not through SW0.

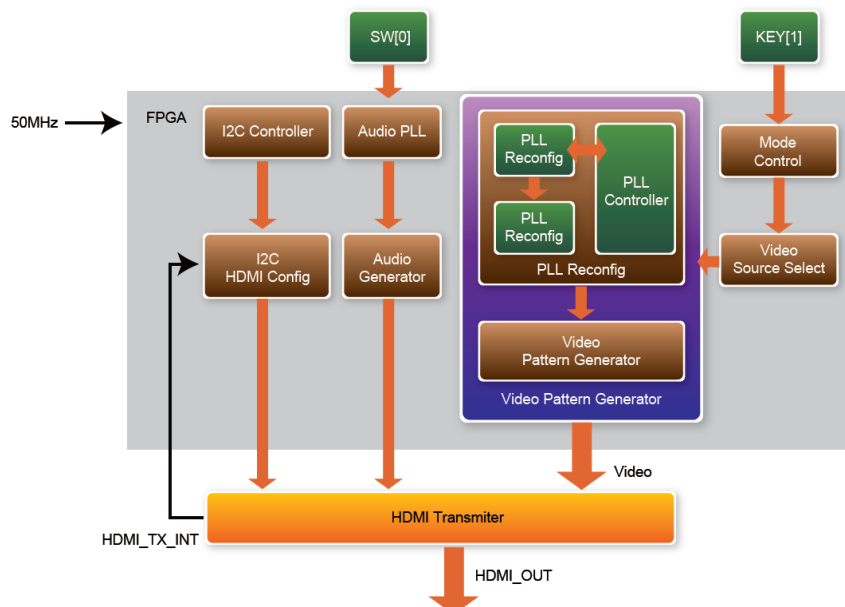

Figure 5-5 Block Diagram of the HDMI TX Demonstration

■ Register of HDMI Transmitter (ADV7513)

Users can save lots of developing time by paying attention to the settings of video format and audio frequency in register at address 0x15 and the format of register at address 0xAF prior to the development of HDMI transmitter. This demo uses 48KHz sampling rate and the video format is 24-bit RGB 4:4:4. For more details, please refer to the document ADV7513_Programming_Guide_R0.pdf.

■ Audio Generator

The ADV7513 can accommodate 2 to 8 channels of I2S audio at up to a 192 KHz sampling rate. The ADV7513 supports I2S standard, left-justified serial audio, and right-justified serial audio. **Figure 5-6** shows the left-justified serial audio with I2S standard audio of 16-bit per channel.

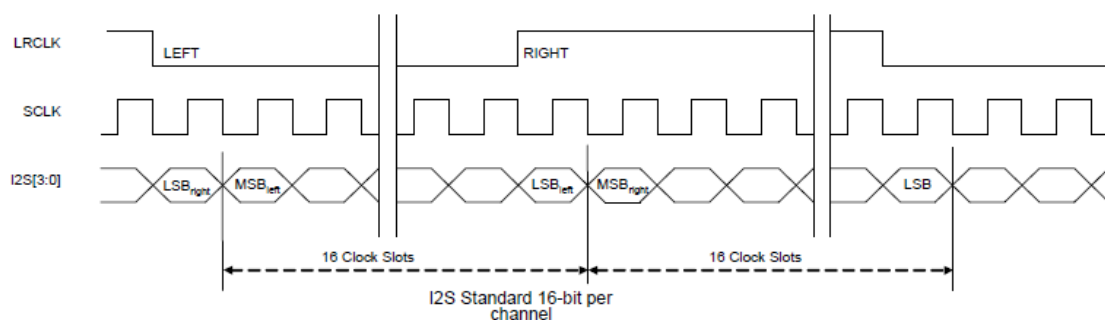

Figure 5-6 I2S standard audio with 16-bit per channel

If users want to modify the frequency of audio output, the register value at register 0x15 has to be modified according to the document ADV7513_Programming_Guide_R0.pdf. The I2S standard uses MSB to LSB serial way of transmitting. This demo uses sinusoid signal to synthesis sound from a reference of look up table created by calculated sinusoid wave data.

■ Video Pattern Generator

The module "Video Pattern Generator" copes with generating video patterns to be presented on the LCD monitor. The pattern is composed in the way of 24-bit RGB 4:4:4 (RGB888 per color pixel without sub-sampling) color encoding, which corresponds to the parallel encoding format defined in **Table 5-1** of the "ADV7513 Hardware User's Guide," as shown below.

Table 5-1 Display modes of the HDMI TX demonstration

Pixel Data [23:0]																	
17	16	15	14	13	12	11	10	9	8	7	6	5	4	3	2	1	0
R[7:0]						G[7:0]						B[7:0]					

A set of display modes is implemented for presenting the generated video patterns. The module "Video Source Selector" controls the selection of current video timing among built-in display modes listed in **Table 5-2**. The module "Mode Control" allows users to switch current display mode alternatively via KEY1.

Table 5-2 Built-in display modes for the HDMI TX demonstration

Pattern ID	Video Format	PCLK (MHZ)
0	640x480@60P	25
1	720x480@60P	27
2	1024x768@60P	65
3	1280x1024@60P	108
4	1920x1080@60P	148.5

■ Demonstration File Locations

- Hardware project directory: \HDMI_TX
- Bitstream used: DE10_Nano_HDMI_TX.sof
- Demo batch file : \HDMI_TX\demo_batch\test.bat

■ Demonstration Setup and Instructions

- Please make sure both Quartus II and USB-Blaster II driver are installed on the host PC.
- Connect the DE10-Nano board to the LCD monitor through a HDMI cable.
- Power on the DE10-Nano board
- Launch the "**test.bat**" batch file from the "**\HDMI_TX\demo_batch**" folder. After the programming and configuration are successful, the screen should look like the one shown in **Figure 5-7** .

```

C:\Windows\system32\cmd.exe
D:\Home\User\Desktop\max10\nick\nick\HDMI_TX\demo_batch>C:\altera\14.1\quartus\
bin64\quartus_pgm.exe -m jtag -c 1 -o "p;HDMI_TX.sof"
Info: *****
Info: Running Quartus II 64-Bit Programmer
Info: Version 14.1.1 Build 188 01/07/2015 SJ Full Version
Info: Copyright (C) 1991-2015 Altera Corporation. All rights reserved.
Info: Your use of Altera Corporation's design tools, logic functions
Info: and other software and tools, and its ANPP partner logic
Info: functions, and any output files from any of the foregoing
Info: (including device programming or simulation files), and any
Info: associated documentation or information are expressly subject
Info: to the terms and conditions of the Altera Program License
Info: Subscription Agreement, the Altera Quartus II License Agreement,
Info: the Altera MegaCore Function License Agreement, or other
Info: applicable license agreement, including, without limitation,
Info: that your use is for the sole purpose of programming logic
Info: devices manufactured by Altera and sold by Altera or its
Info: authorized distributors. Please refer to the applicable
Info: agreement for further details.
Info: Processing started: Fri Jan 23 19:21:21 2015
Info: Command: quartus_pgm -m jtag -c 1 -o p;HDMI_TX.sof
Info (213045): Using programming cable "Arrow MAX 10 DECA IUSB-11"
Info (213011): Using programming file HDMI_TX.sof with checksum 0x002A192F for d
evice 10M50DAF48401
Info (209060): Started Programmer operation at Fri Jan 23 19:21:22 2015
Info (209016): Configuring device index 1
Info (209017): Device 1 contains JTAG ID code 0x031050DD
Info (209007): Configuration succeeded -- 1 device(s) configured
Info (209011): Successfully performed operation(s)
Info (209061): Ended Programmer operation at Fri Jan 23 19:21:22 2015
Info: Quartus II 64-Bit Programmer was successful. 0 errors, 0 warnings
Info: Peak virtual memory: 251 megabytes
Info: Processing ended: Fri Jan 23 19:21:22 2015
Info: Elapsed time: 00:00:01
Info: Total CPU time (on all processors): 00:00:01
D:\Home\User\Desktop\max10\nick\nick\HDMI_TX\demo_batch>pause
請按任意鍵繼續 . . .

```

Figure 5-7 Launch the HDMI TX demonstration from the "demo_batch" folder

Wait for a few seconds for the LCD monitor to be powered up. There will be a pre-defined video pattern shown on the monitor, as shown in **Figure 5-8**. The SW0 is used to enable/disable the sound output on the DE10-Nano board. When you switch the SW0 button to an upper position, you will hear a "beep" sound from the speaker of the HDMI display.

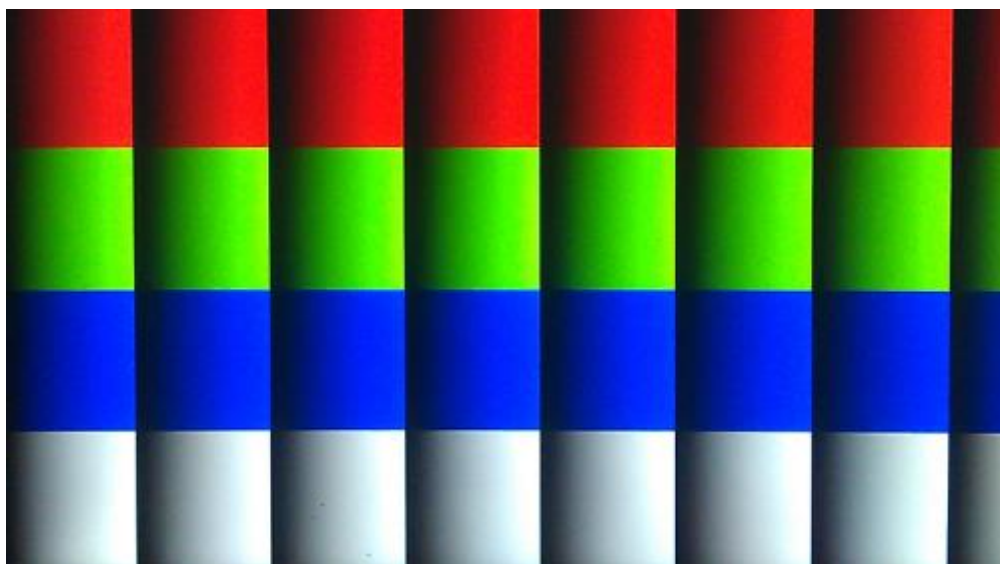

Figure 5-8 The video pattern in the HDMI TX demonstration

5.4 DDR3_VIP

This demonstration shows how to use HPS DDR3 as an external buffer of the frame buffer IP in an FPGA based video pattern generator. The video pattern generator is implemented based on the VIP (Video and Image Processing) suite. Before running the FPGA demo, users have to boot the DE10-Nano from HPS to execute the **Preloader, Bootloader, and soc_system.rbf** programs from the microSD card for HPS and DDR3 initialization. The required microSD card image, **terasic_hps_ddr3.img**, is provided in the DE10-Nano System CD.

■ System Block Diagram

Figure 5-9 shows the system block diagram of this reference design. In this HPS site, the **Preloader, Bootloader, and soc_system.rbf** programs are loaded from the microSD card and are executed to initialize the HPS and DDR3 memory. The **Bootloader** will make the HPS LED light up to indicate the DDR3 is ready, at which point the user runs the **soc_system.rbf**; this will configure the FPGA.

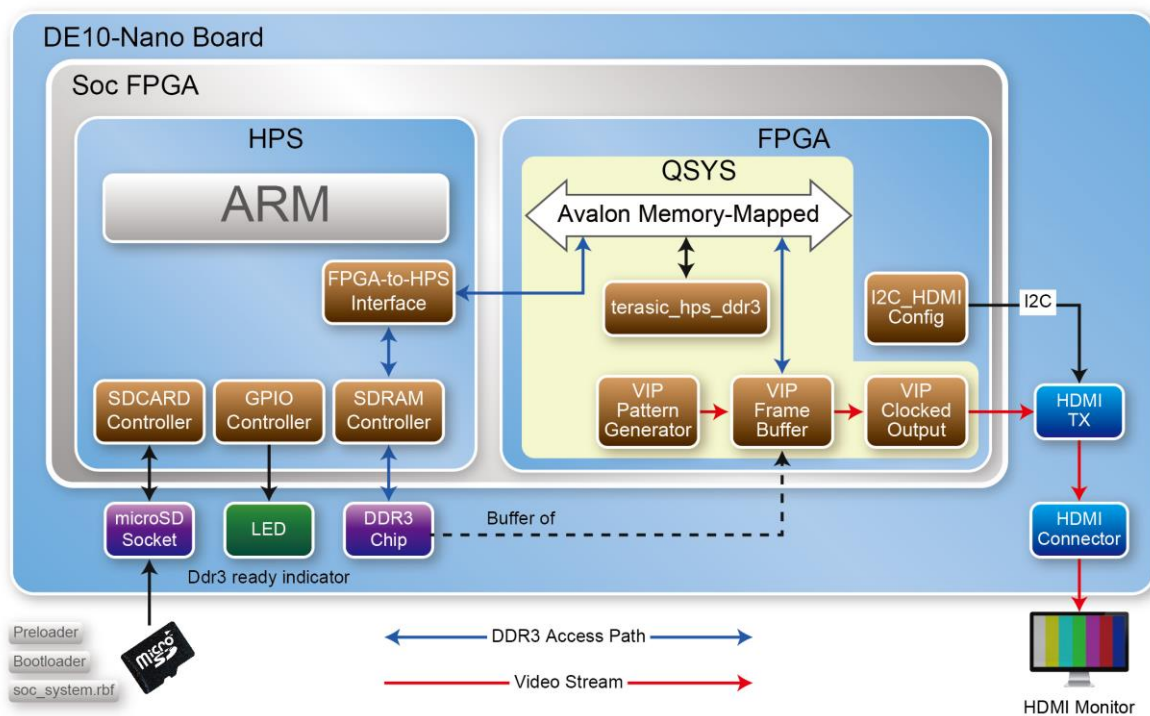

Figure 5-9 Block Diagram of the DDR3_VIP Demonstration

In the FPGA site, the `terasic_hps_ddr3` sub-system, provided by Terasic, is used to provide a bridge between the FPGA and the HPS DDR3. The VIP suite is used to implement the pattern generator, and the HPS DDR3 is used as a buffer for the VIP **Frame Buffer II**. The frame buffer accesses the DDR3 through the FPGA-to-HPS interface and SDRAM Controller. The FPGA-to-HPS interface is configured as a 128-bits Avalon Memory-Mapped Bidirectional port. The VIP **Test Pattern Generator II** is used to generate a 1024x767 color pattern, the VIP **Clocked Video Output II** is used to generate VGA video format. For HDMI displaying, the on-board HDMI transmitter chip is used to display the video pattern. The `I2C_HDMI_Config` block is used to configure HDMI TX chip through the I2C interface of the HDMI chip. For details about the HDMI TX chip controller, please refer to `HDMI_TX` example in this kit.

■ DDR3 Access Interface

In this demonstration, a QSYS sub-system `terasic_hps_ddr3.qsys` is used to provide a bridge between the FPGA and the HPS DDR3 controller. `terasic_hps_ddr3` sub-system is included in the Qsys top design, and both `mem_master_wr` and `mem_master_rd` AVMM master ports of **Frame Buffer II (4K Ready)** are connected to the `f2h_sdram0_data` AVMM slave port of `terasic_hps_ddr3` as shown in **Figure 5-10**. Interfaces `hps_0_hps_io` and `memory` are exported for connecting to HPS pins in Quartus top as shown in **Figure 5-11**.

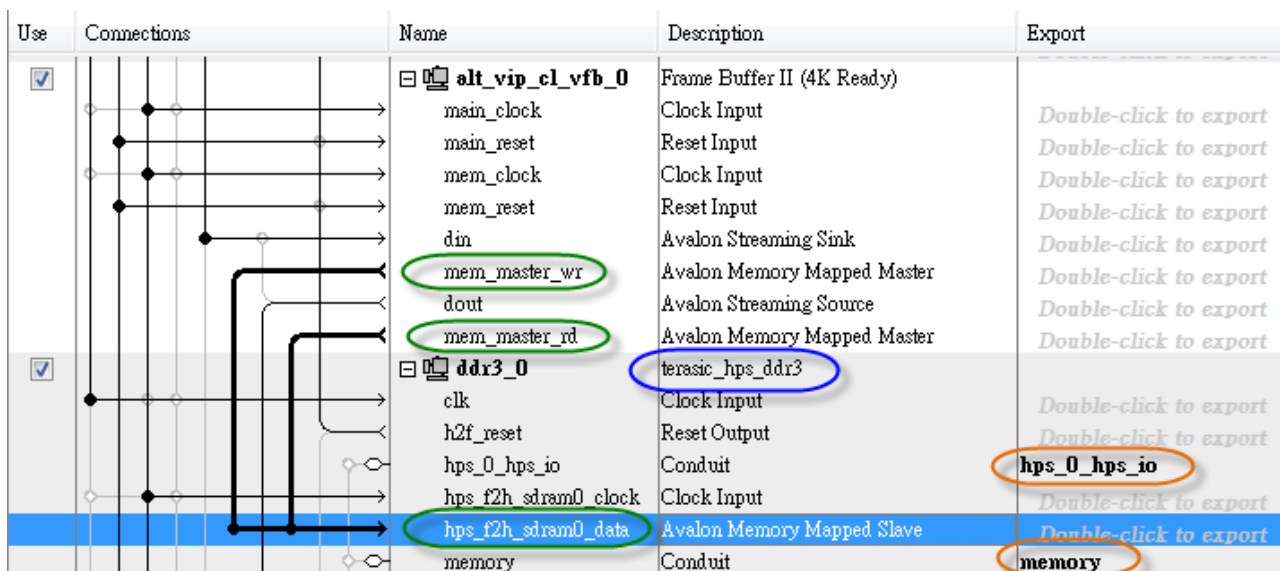

Figure 5-10 Qsys top of DDR3_VIP

```

soc_system u0 (
  //Clock&Reset
  .clk_clk ( FPGA_CLK1_50 ),
  //HPS ddr3
  .memory_mem_a ( HPS_DDR3_ADDR ),
  .memory_mem_ba ( HPS_DDR3_BA ),
  .memory_mem_ck ( HPS_DDR3_CK_P ),
  .memory_mem_ck_n ( HPS_DDR3_CK_N ),
  .memory_mem_cke ( HPS_DDR3_CKE ),
  .memory_mem_cs_n ( HPS_DDR3_CS_N ),
  .memory_mem_ras_n ( HPS_DDR3_RAS_N ),
  .memory_mem_cas_n ( HPS_DDR3_CAS_N ),
  .memory_mem_we_n ( HPS_DDR3_WE_N ),
  .memory_mem_reset_n ( HPS_DDR3_RESET_N ),
  .memory_mem_dq ( HPS_DDR3_DQ ),
  .memory_mem_dqs ( HPS_DDR3_DQS_P ),
  .memory_mem_dqs_n ( HPS_DDR3_DQS_N ),
  .memory_mem_odt ( HPS_DDR3_ODT ),
  .memory_mem_dm ( HPS_DDR3_DM ),
  .memory_oct_rzqin ( HPS_DDR3_RZQ ),
  //HPS SD card
  .hps_0_hps_io_hps_io_sdio_inst_CMD ( HPS_SD_CMD ), //
  .hps_0_hps_io_hps_io_sdio_inst_D0 ( HPS_SD_DATA[0] ), //
  .hps_0_hps_io_hps_io_sdio_inst_D1 ( HPS_SD_DATA[1] ), //
  .hps_0_hps_io_hps_io_sdio_inst_CLK ( HPS_SD_CLK ), //
  .hps_0_hps_io_hps_io_sdio_inst_D2 ( HPS_SD_DATA[2] ), //
  .hps_0_hps_io_hps_io_sdio_inst_D3 ( HPS_SD_DATA[3] ), //
  //HPS UART
  .hps_0_hps_io_hps_io_uart0_inst_RX ( HPS_UART_RX ), //
  .hps_0_hps_io_hps_io_uart0_inst_TX ( HPS_UART_TX ), //
  .hps_0_hps_io_hps_io_gpio_inst_GPIO53 ( HPS_LED ), //
  ...
)

```

Figure 5-11 Pin connections on Quartus top

■ FPGA configure from HPS

You can also configure the FPGA through the usb-blaster JTAG interface. The FPGA can also be configured by **Bootloader** in the microSD card. When the DE10-Nano is booted from HPS, the Bootloader will configure the FPGA by the configuration file **soc_system.rbf** which is also provided in the microSD card. The **soc_system.rbf** file can be generated from a .sof file by applying a batch file **sof_to_rbf.bat**. The batched file is provided by Terasic, and is located in the VIP_DDR3 folder. The batch call utility **quarthps_cpf.exe** to translate DDR3_VIP.sof to soc_system.rbf.

Before copying this **soc_system.rbf** into the MicroSD card, please make sure the microSD card is programmed with the Linux Image file **terasic_hsp_ddr3_init.img** which is located at

CD\Demonstration\FPGA\SdcardImage\terasic_hsp_ddr3.img

For details about how to program the **terasic_hsp_ddr3.img** into the microSD card, please refer to **Getting_Started_Guide.pdf** document in this kit.

The procedures on how to generate and copy the soc_system.rbf into the microSD card are listed below:

- Make sure the DDR3_VIP.sof file is up to date on the DDR3_VIP project folder
- Execute sof_to_rbf.bat to generate **soc_system.rbf**
- Make sure the microSD card is programmed to contain the Linux image erasic_hps_ddr3.img
- Insert the MicroSD card into your host PC
- Copy **soc_system.rbf** to root folder of the microSD card. (Overwrite soc_system.rbf if there is an old version)

■ Demonstration File Locations

The Quartus project information is shown below:

- FPGA Quartus project location: CD\Demonstrations\FPGA\DDR3_VIP
- Demo batch file location : CD\Demonstrations\FPGA\DDR3_VIP\demo_batch
- Bitstream File Name: DDR3_VIP.sof
- RBF Filename: soc_system.rbf

The location of the Linux image to program microSD is specified below. Please refer to Getting_Started_Guide.pdf about how to program the Linux image into a microSD card by using Win32DiskImager.exe.

CD\Demonstrations\FPGA\SdcardImage\terasic_hps_ddr3.img

■ Demonstration Setup and Instructions by SOF File

Please follow the instruction listed below to configure the FPGA with the .sof file through the usb-blaster JTAG interface to perform the demonstration.

- Make sure both Quartus II and USB-Blaster II drivers are installed on the host PC
- Connect the DE10-Nano board to the LCD monitor through an HDMI cable
- Program terasic_hps_ddr3.img into a microSD card
- Insert the microSD card into the DE10-Nano board
- Make sure the MSEL[4:0] is set to 01010
- Connect a mini-USB cable to UB2 port of DE10-Nano and the host PC

- Power on the DE10-Nano board
- Wait until HPS LED0 is lighted. This indicate the DDR3 is ready
- Launch the "test.bat" batch file from the "\\DDR3_VIP\\demo_batch" folder. After the programming and configuration are successful, the screen should look like the one shown in **Figure 5-12** .
- Wait for a few seconds for the LCD monitor to be powered up. There will be a pre-defined 1024x768 video pattern shown on the monitor, as shown in **Figure 5-13**.

```

C:\Windows\system32\cmd.exe
F:\nick\temp>E:\altera\16.0\quartus\bin64\quartus_pgm.exe -m jtag -c 1 -o "p;DDR3_VIP.sof@2"
Info: *****
Info: Running Quartus Prime Programmer
Info: Version 16.0.2 Build 222 07/20/2016 SJ Standard Edition
Info: Copyright (C) 1991-2016 Altera Corporation. All rights reserved.
Info: Your use of Altera Corporation's design tools, logic functions
Info: and other software and tools, and its AMPP partner logic
Info: functions, and any output files from any of the foregoing
Info: (including device programming or simulation files), and any
Info: associated documentation or information are expressly subject
Info: to the terms and conditions of the Altera Program License
Info: Subscription Agreement, the Altera Quartus Prime License Agreement,
Info: the Altera MegaCore Function License Agreement, or other
Info: applicable license agreement, including, without limitation,
Info: that your use is for the sole purpose of programming logic
Info: devices manufactured by Altera and sold by Altera or its
Info: authorized distributors. Please refer to the applicable
Info: agreement for further details.
Info: Processing started: Tue Dec 20 11:39:51 2016
Info: Command: quartus_pgm -m jtag -c 1 -o p;DDR3_VIP.sof@2
Info (213045): Using programming cable "DE-SoC [USB-1]"
Info (213011): Using programming file DDR3_VIP.sof with checksum 0x019979FC for
device 5CSEBA6U23@2
Info (209060): Started Programmer operation at Tue Dec 20 11:39:53 2016
Info (209016): Configuring device index 2
Info (209017): Device 2 contains JTAG ID code 0x02D020DD
Info (209007): Configuration succeeded -- 1 device(s) configured
Info (209011): Successfully performed operation(s)
Info (209061): Ended Programmer operation at Tue Dec 20 11:39:55 2016
Info: Quartus Prime Programmer was successful. 0 errors, 0 warnings
Info: Peak virtual memory: 291 megabytes
Info: Processing ended: Tue Dec 20 11:39:55 2016
Info: Elapsed time: 00:00:04
Info: Total CPU time (on all processors): 00:00:01

F:\nick\temp>pause
請按任意鍵繼續 . . .

```

Figure 5-12 Launch the DDR3_VIP demonstration from the "demo_batch" folder

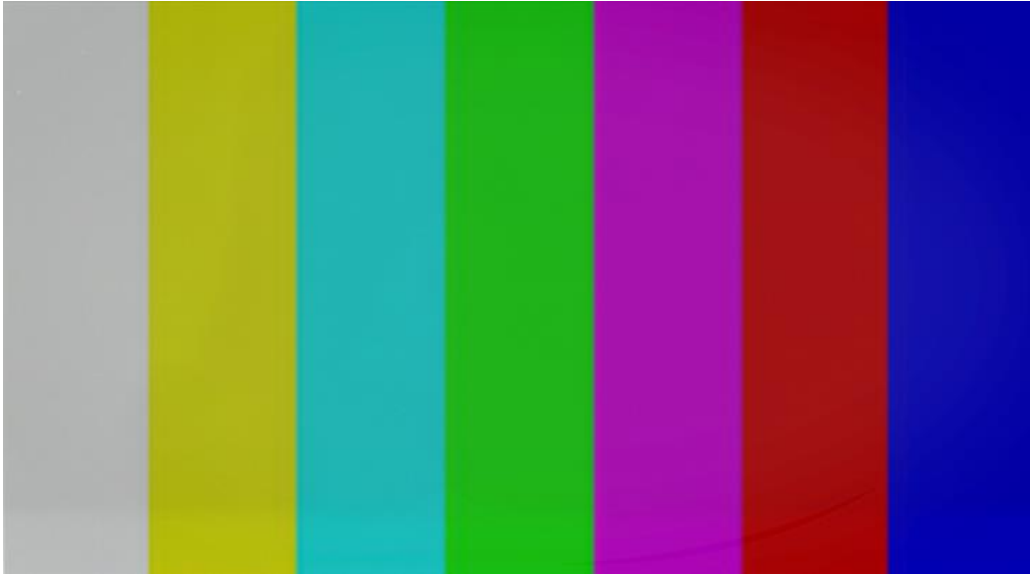

Figure 5-13 The video pattern in the DDR3_VIP demonstration

■ Demonstration Setup and Instructions by RBF File

Please follow the instructions below to configure FPGA with **soc_system.rbf** file to perform the demonstration. In this demonstration case, FPGA is configured by **Bootloader** which read the configuration file **soc_system.rbf** from the microSD card. In this demonstration setup, no USB cable is required.

- Connect the DE10-Nano board to the LCD monitor through a HDMI cable
- Programming **terasic_hps_ddr3.img** into a microSD card
- Copy the RBF file **soc_system.rbf** into the microSD card
- Insert the microSD card into the DE10-Nano board
- Make sure the MSEL[4:0] is set to 01010
- Power on the DE10-Nano board
- Wait for a few seconds for the LCD monitor to be powered up. There will be a 1024x768 video pattern shown on the monitor

5.5 DDR3_RTL

This demonstration describes how the RTL code on the FPGA site accesses the DDR3 on the HPS site and performs write & read back verify tests. A Qsys sub-system `terasic_dds3.qsys` is used in the Qsys top. This sub-system exports an Avalon memory-mapped interface for the DDR3 on the HPS site. In this case, the RTL code can access the DDR3 through the Avalon memory-mapped interface.

Before running the FPGA demo, users have to make the DE10-Nano boot from HPS to execute the **Preloader**, **Bootloader**, and **soc_system.rbf** programs from the microSD card for the HPS and DDR3 initialization. The required microSD card image, called **terasic_hps_dds3.img**, is provided in the DE10-Nano System CD.

■ System Block Diagram

Figure 5-14 shows the system block diagram of this reference design. In this HPS site, the **Preloader**, **Bootloader**, and **soc_system.rbf** programs are loaded from the microSD card and are executed to initialize the HPS and DDR3 memory. The **Bootloader** will make the HPS LED light up to indicate the DDR3 is ready; use **soc_system.rbf** to configure the FPGA.

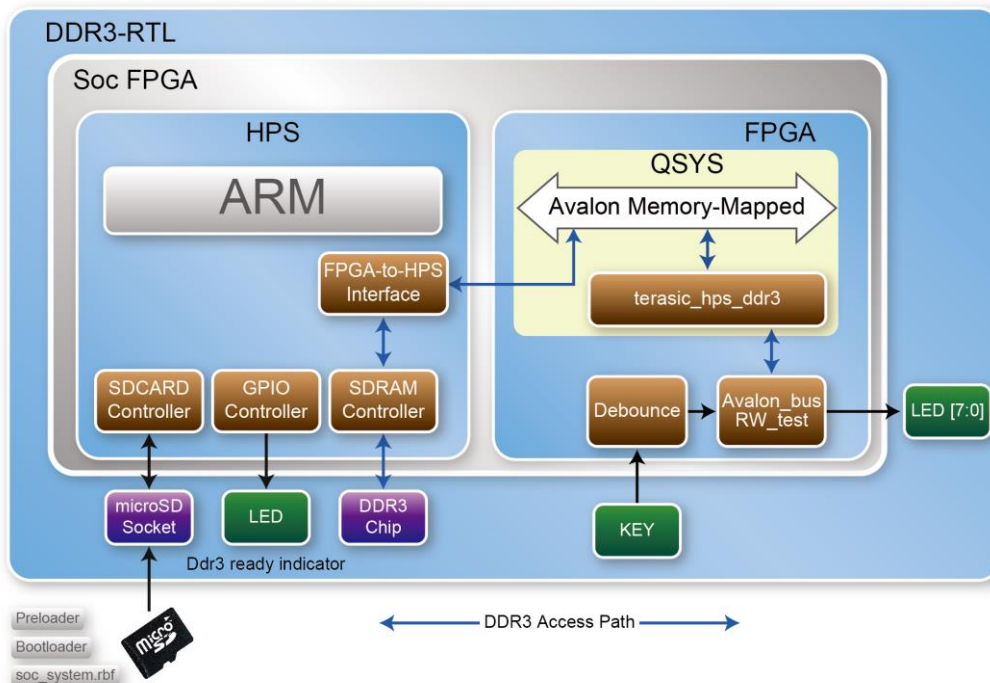

Figure 5-14 Block Diagram of the DDR3_RTL Demonstration

In the FPGA site, the **terasic_hps_ddr3** sub-system, provided by Terasic, is used to provide a bridge between FPGA and HPS DDR3. **Avalon_bus_RW_test** is a memory test module. It performs memory write and read back verification. It accesses the DDR3 through the FPGA-to-HPS interface and SDRAM Controller. The FPGA-to-HPS interface is configured as a 128-bits Avalon Memory-Mapped Bidirectional port. When users press KEY0, the memory test is started. The test progression and test results will be indicated in the LED[2:0]. The de-bounce block is used to avoid multiple trigger due to the key bounding.

■ DDR3 Access Interface

In this demonstration, a QSYS sub-system **terasic_hps_ddr3.qsys** is used to provide a bridge between the FPGA and the HPS DDR3 controller. In the Qsys top design, **terasic_hps_ddr3** sub-system is included. The **hps_f2h_sdram_data** interface should be exported to quartus top, such that the test module can access the DDR3 through the Avalon Memory-Mapped interface as shown in **Figure 5-15**. Besides, interfaces **hps_0_hps_io** and **memory** also should be exported for connecting to the HPS pins in Quartus top as shown in **Figure 5-16**.

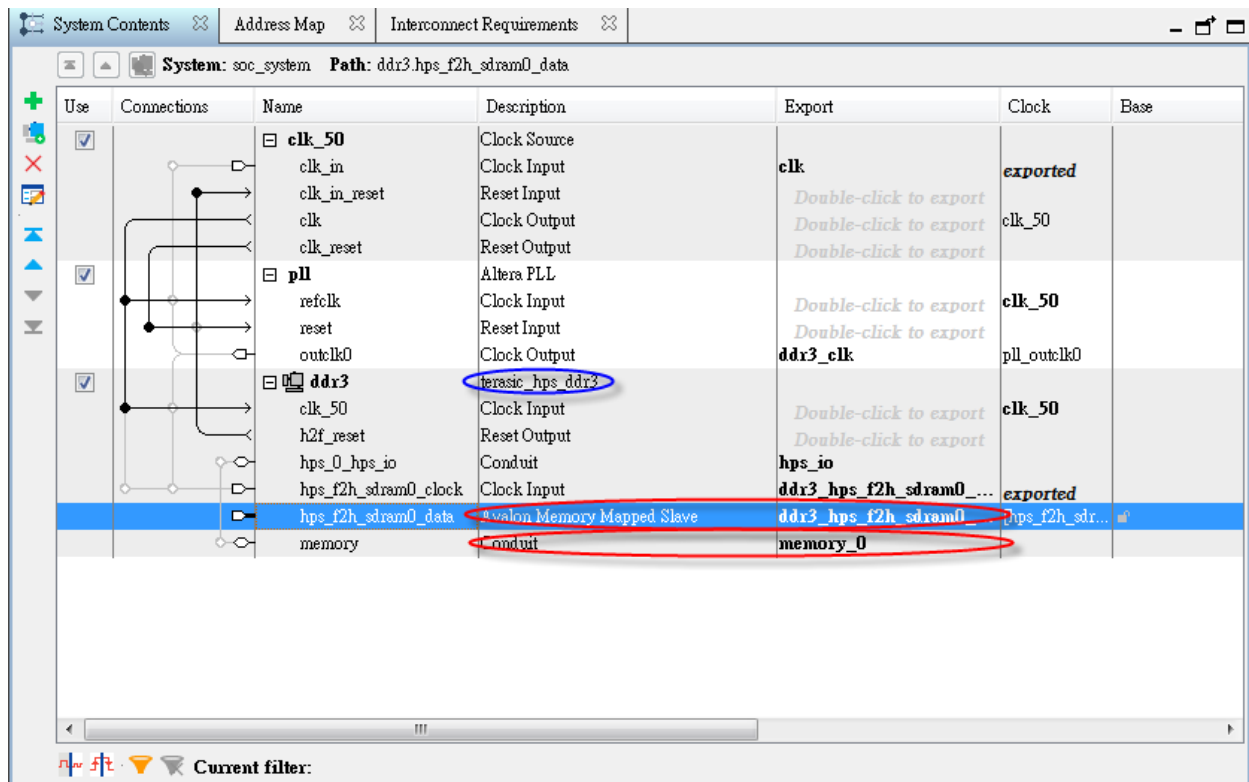

Figure 5-15 Qsys top of DDR3_RTL

```

.hps_io_hps_io_sdio_inst_CMD      ( HPS_SD_CMD      ),           //
.hps_io_hps_io_sdio_inst_D0      ( HPS_SD_DATA[0]  ),           //
.hps_io_hps_io_sdio_inst_D1      ( HPS_SD_DATA[1]  ),           //
.hps_io_hps_io_sdio_inst_CLK     ( HPS_SD_CLK     ),           //
.hps_io_hps_io_sdio_inst_D2      ( HPS_SD_DATA[2]  ),           //
.hps_io_hps_io_sdio_inst_D3      ( HPS_SD_DATA[3]  ),           //
//HPS UART
.hps_io_hps_io_uart0_inst_RX     ( HPS_UART_RX    ),           //
.hps_io_hps_io_uart0_inst_TX     ( HPS_UART_TX    ),           //
.hps_io_hps_io_gpio_inst_GPIO53  ( HPS_LED       ),           //
//HPS ddr3
.memory_0_mem_a                  ( HPS_DDR3_ADDR),
.memory_0_mem_ba                  ( HPS_DDR3_BA),
.memory_0_mem_ck                  ( HPS_DDR3_CK_P),
.memory_0_mem_ck_n                ( HPS_DDR3_CK_N),
.memory_0_mem_cke                 ( HPS_DDR3_CKE),
.memory_0_mem_cs_n                ( HPS_DDR3_CS_N),
.memory_0_mem_ras_n               ( HPS_DDR3_RAS_N),
.memory_0_mem_cas_n               ( HPS_DDR3_CAS_N),
.memory_0_mem_we_n                ( HPS_DDR3_WE_N),
.memory_0_mem_reset_n             ( HPS_DDR3_RESET_N),
.memory_0_mem_dq                  ( HPS_DDR3_DQ),
.memory_0_mem_dqs                  ( HPS_DDR3_DQS_P),
.memory_0_mem_dqs_n               ( HPS_DDR3_DQS_N),
.memory_0_mem_odt                  ( HPS_DDR3_ODT),
.memory_0_mem_dm                   ( HPS_DDR3_DM),
.memory_0_oct_rzqin                ( HPS_DDR3_RZQ),
//DDR3 Avalon Read write
.ddr3_hps_f2h_sdram0_clock_clk    (DDR3_CLK),
.ddr3_hps_f2h_sdram0_data_address (ddr3_av1_addr),
.ddr3_hps_f2h_sdram0_data_read    (ddr3_av1_read_req),
.ddr3_hps_f2h_sdram0_data_readdata (ddr3_av1_rdata),
.ddr3_hps_f2h_sdram0_data_write   (ddr3_av1_write_req),
.ddr3_hps_f2h_sdram0_data_writedata (ddr3_av1_wdata),
.ddr3_hps_f2h_sdram0_data_readdatavalid (ddr3_av1_rdata_valid),
.ddr3_hps_f2h_sdram0_data_waitrequest (ddr3_av1_ready),
.ddr3_hps_f2h_sdram0_data_byteenable (16'hffff),
.ddr3_hps_f2h_sdram0_data_burstcount (ddr3_av1_size)

```

Figure 5-16 Pin connections on Quartus top

■ FPGA configure from HPS

Besides configuring FPGA through the usb-blaster JTAG interface. The FPGA can also be configured via **Bootloader** in the microSD card. When DE10-Nano is booted from HPS, the Bootloader will configure the FPGA by the configuration file **soc_system.rbf** which is also provided in the microSD card. The **soc_system.rbf** file can be generated from a .sof by applying a batch file **sof_to_rbf.bat**. The batched file is provided by Terasic, and is located in the DDR3_RTL folder. The batch calls quatus_cpf.exe and this utility will convert DDR3_RTL.sof to soc_system. Before copying this **soc_system.rbf** into the MicroSD card, please make sure the microSD card is programmed with the Linux Image file **terasic_hsp_ddr3_init.img** located at

CD\Demonstration\FPGA\SdcardImage\terasic_hps_ddr3.img

For details about how to program the **terasic_hps_ddr3.img** into the microSD card, Please refer to **Getting_Started_Guide.pdf** document in this kit.

Here are the procedure to generate and copy the **soc_system.rbf** into the microSD card:

- Make sure the DDR3_RTL.sof file is up to date on the DDR3_RTL project folder
- Execute the sof_to_rbf.bat to generate **soc_system.rbf**
- Make sure the re-programmed microSD card contains the Linux image erasic_hps_ddr3.img
- Insert the MicroSD card into your host PC
- Copy **soc_system.rbf** to root folder of the microSD card. (If an old one exists, overwrite it with soc_system.rbf)

■ Demonstration File Locations

The Quartus project information is shown below:

- FPGA Quartus project location: CD\Demonstrations\FPGA\DDR3_RTL
- Demo batch file location : CD\Demonstrations\FPGA\DDR3_RTL\demo_batch
- Bitstream File Name: DDR3_RTL.sof
- RBF Filename: soc_system.rbf

The location of the Linux image to program microSD is specified below. Please refer to Getting_Started_Guide.pdf about how to program the Linux image into a microSD card by using Win32DiskImager.exe.

CD\Demonstrations\FPGA\SdcardImage\terasic_hps_ddr3.img

■ Demonstration Setup and Instructions by SOF File

Please follow below instructions to configure FPGA with .sof file through the usb-blaster JTAG interface to performance the demonstration.

- Make sure both Quartus II and USB-Blaster II driver are installed on the host PC.
- Program terasic_hps_ddr3.img into a microSD card.
- Insert the microSD card into the DE10-Nano board.
- Make sure the MSEL[4:0] is set to 01010.
- Connect a mini-USB cable to UB2 port of DE10-Nano and the host PC.

- Power on the DE10-Nano board
- Wait the HPS LED0 is lighted. This indicates the DDR3 is ready.
- Launch the "test.bat" batch file from the "\DDR3_RTL\demo_batch" folder. After the programming and configuration are successful, the screen should look like the one shown in **Figure 5-17**.
- Press KEY0 to start memory test.
- The LED[3:0] will show test progression and test result. Please refer to **Table 5-3** LED representations.

```

C:\Windows\system32\cmd.exe
F:\nick\demo_batch>E:\intelFPGA\16.1\quartus\bin64\quartus_pgm.exe -m jtag -c
1 -o "p;DDR3_RTL.sof@2"
Info: *****
Info: Running Quartus Prime Programmer
Info: Version 16.1.1 Build 200 11/30/2016 SJ Standard Edition
Info: Copyright (C) 2016 Intel Corporation. All rights reserved.
Info: Your use of Intel Corporation's design tools, logic functions
Info: and other software and tools, and its AMPP partner logic
Info: functions, and any output files from any of the foregoing
Info: (including device programming or simulation files), and any
Info: associated documentation or information are expressly subject
Info: to the terms and conditions of the Intel Program License
Info: Subscription Agreement, the Intel Quartus Prime License Agreement,
Info: the Intel MegaCore Function License Agreement, or other
Info: applicable license agreement, including, without limitation,
Info: that your use is for the sole purpose of programming logic
Info: devices manufactured by Intel and sold by Intel or its
Info: authorized distributors. Please refer to the applicable
Info: agreement for further details.
Info: Processing started: Wed Dec 28 10:51:48 2016
Info: Command: quartus_pgm -m jtag -c 1 -o p;DDR3_RTL.sof@2
Info (213045): Using programming cable "DE-SoC [USB-1]"
Info (213011): Using programming file DDR3_RTL.sof with checksum 0x00B89A03 for
device 5CSEBA6U23@2
Info (209060): Started Programmer operation at Wed Dec 28 10:51:50 2016
Info (209016): Configuring device index 2
Info (209017): Device 2 contains JTAG ID code 0x02D020DD
Info (209007): Configuration succeeded -- 1 device(s) configured
Info (209011): Successfully performed operation(s)
Info (209061): Ended Programmer operation at Wed Dec 28 10:51:52 2016
Info: Quartus Prime Programmer was successful. 0 errors, 0 warnings
Info: Peak virtual memory: 306 megabytes
Info: Processing ended: Wed Dec 28 10:51:52 2016
Info: Elapsed time: 00:00:04
Info: Total CPU time (on all processors): 00:00:01
F:\nick\demo_batch>pause
請按任意鍵繼續 . . .

```

Figure 5-17 Launch the DDR3_RTL demonstration from the "demo_batch" folder

Table 5-3 LED Indicators

Nane	Description
LED0	Reset
LED1	DDR3 Test Pass result
LED2	DDR3 Test Complete result
LED3	DDR3 Test Fail result
LED7	50MHz clock source

■ Demonstration Setup and Instructions by RBF File

Please following instructions below to configure the FPGA with **soc_system.rbf** file to perform the demonstration. In the case of this demonstration, the FPGA is configured by **Bootloader** which reads the configuration file **soc_system.rbf** from the microSD card. In this demonstration setup, no USB cable is required.

- Programming terasic_hps_ddr3.img into a microSD card.
- Copy the RBF file **soc_system.rbf** into the microSD card.
- Insert the microSD card into the DE10-Nano board.
- Make sure the MSEL[4:0] is set to 01010.
- Power on the DE10-Nano board.
- Press KEY0 to start memory test.
- The LED[3:0] will show test progression and test result. Please refer to **Table 5-3** LED representations.

5.6 Nios II Access HPS DDR3

This demonstration shows how the FPGA can use the HPS DDR3 memory indirectly without effecting the functionality of the Linux system on HPS. First, it shows how to configure Linux kernel so the HPS/ARM only uses the bottom 512MB DDR3 memory. In this case, the remaining 512MB DDR3 memory will be used by the FPGA. Also, we show how the FPGA accesses the DDR3 memory through the **F2H SDRAM** interface in the HPS component. In the demonstration, a **Nios2** processor is used as the master in the FPGA to write and read the pattern data to the DDR3 memory.

■ System Block Diagram

Figure 5-18 is the block diagram of this demonstration. In this HPS side, DDR3 chips are connected to the **SDRAM controller**, and the FPGA can access the top 512MB of DDR3 through the **F2H SDRAM** interface and the SDRAM controller. The **F2H SDRAM** interface is configured as a 32-bit with Avalon bus in this demonstration.

In the FPGA side, the on-chip memory is used as the **Nios2** instruction and data memory. Because the **F2H SDRAM** interface has a 32-bit address expansion, directly linking **Nios2** data port to the **F2H SDRAM** interface exceeds **Nios2** 32-bit address range. So, the **Address Span Extender** component is used as a bridge between the **Nios2** data port and the **F2H SDRAM** interface. In the **Address Span Extender** component, Slave Word Address Width parameter is set as 27-bit so the address span is 512 megabytes. The

sub-window offset parameter is set at 0x20000000, so the starting physical address for **Nios2** accessing the DDR3 is 512MB offset to the DDR3.

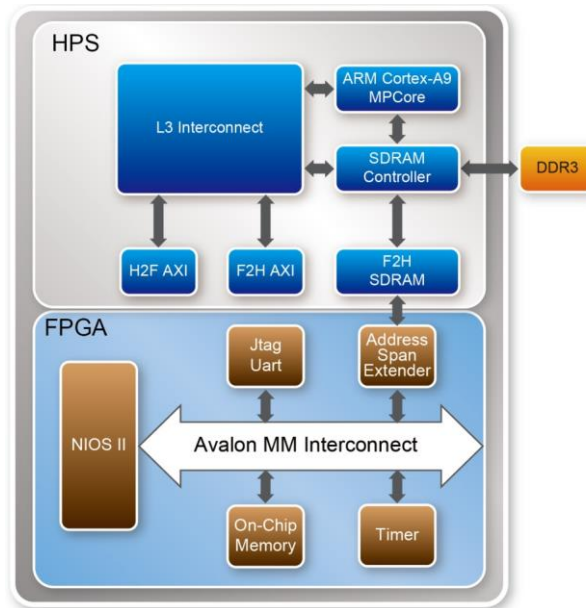

Figure 5-18 Nios2 Access DDR3 Block Diagram

Figure 5-19 shows the **F2H SDRAM** Interface setting in the HPS component in the Qsys tool. The interface type Avalon-MM Bidirectional is selected and the data width 32-bit is used.

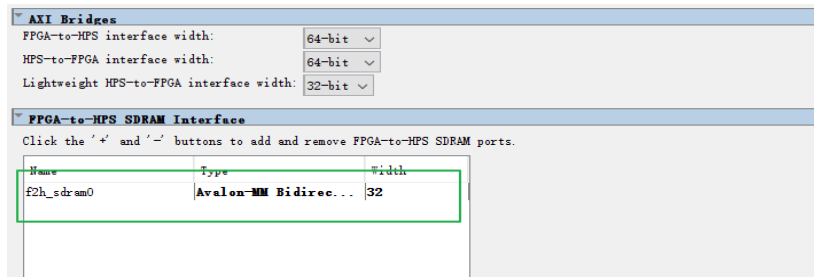

Figure 5-19 F2H SDRAM Interface Setting

■ System Requirements

The following items are required to perform this demonstration.

- DE10-Nano board x1
- Mini-USB cable
- Win7 operate system with Quartus II 16.0 installed
- At least 4G Micro SD and MicroSD reader.
- Putty tool and Win32DiskImager

■ Demonstration File Locations

The Linux image can be downloaded from Terasic DE10-Nano web page Linux Console Image. Please refer to *Getting_Started_Guide.pdf* for writing the image to the MicroSD card.

The Quartus/Nios2 projects are located in the Demonstration\SoC_FPGA folder of the DE10-Nano.

- Quartus Project: Nios_Access_DDR3
- NIOS II Project: Nios_Access_DDR3\nios_software
- Demo Batch File Nios_Access_DDR3\demo_batch

■ Demonstration step up

Follow the below instructions to perform the demonstration.

- Execute the **sof_to_rbf.bat** in the demo_batch folder to generate soc_system.rbf
- Insert the MicroSD card into your host PC
- Copy soc_system.rbf to the root folder of the microSD card. (Overwrite the soc_system.rbf if there is an old version.)
- Insert the MicroSD card into the DE10-Nano.
- Make sure the MSEL[4:0] is set to 01010.
- Connect another mini-usb cable to the J4 on the DE10-Nano and the host PC for HPS/Linux boot.
- Open the putty and power up the board. Before the count down finishes, hit any key to enter the u-boot mode, as shown in **Figure 5-20**.

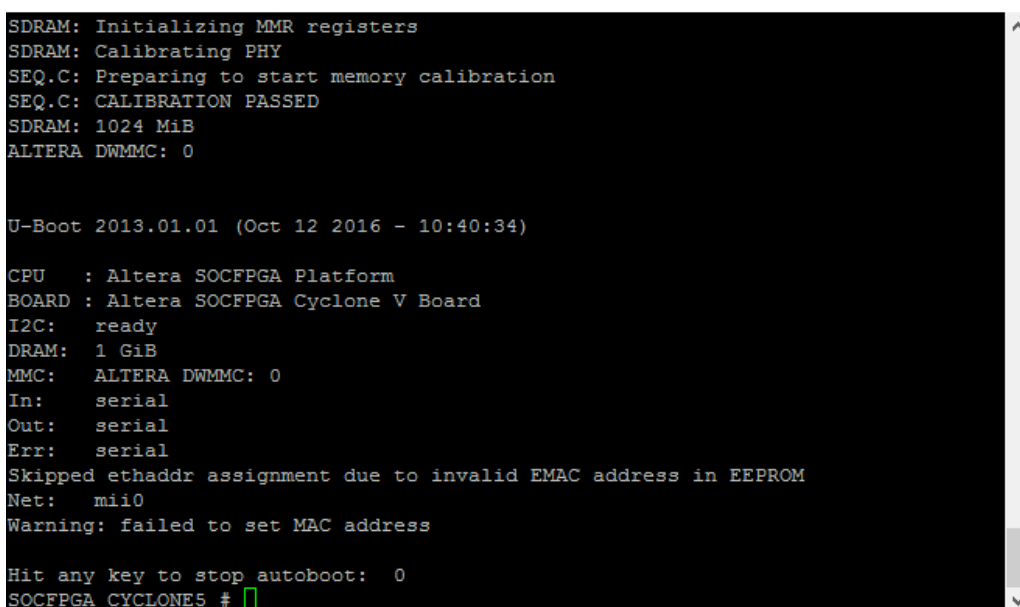

```
SDRAM: Initializing MMR registers
SDRAM: Calibrating PHY
SEQ.C: Preparing to start memory calibration
SEQ.C: CALIBRATION PASSED
SDRAM: 1024 MiB
ALTERA DWMMC: 0

U-Boot 2013.01.01 (Oct 12 2016 - 10:40:34)

CPU   : Altera SOCFPGA Platform
BOARD : Altera SOCFPGA Cyclone V Board
I2C:   ready
DRAM:  1 GiB
MMC:   ALTERA DWMMC: 0
In:    serial
Out:   serial
Err:   serial
Skipped ethaddr assignment due to invalid EMAC address in EEPROM
Net:   mio
Warning: failed to set MAC address

Hit any key to stop autoboot:  0
SOCFPGA_CYCLONE5 #
```

Figure 5-20 HPS U-Boot Terminal

- Type the following instruction in the terminal as in **Figure 5-21** to set the Linux system to only use the low 512MB memory in DDR3.

User can copy the content and paste into the terminal:

```
setenv mmcboot "setenv bootargs console=ttyS0,115200 root=/dev/mmcblk0p2 rw \
rootwait mem=512M;bootz 0x8000 - 0x00000100"
```

```
Err: serial
Skipped ethaddr assignment due to invalid EMAC address in EEPROM
Net: mii0
Warning: failed to set MAC address

Hit any key to stop autoboot: 0
SOCFPGA_CYCLONE5
SOCFPGA_CYCLONE5 # print bootcmd
bootcmd=run callscript; run mmcload; run mmcboot
SOCFPGA_CYCLONE5 # print mmcboot
mmcboot=setenv bootargs console=ttyS0,115200 root=/dev/mmcblk0p2 rw rootwait mem
=512M;bootz 0x8000 - 0x00000100
SOCFPGA_CYCLONE5 #
```

Figure 5-21 Set Linux Memory

- Type **env save** command to save the setting as in **Figure 5-22**

```
SOCFPGA_CYCLONE5 # setenv mmcboot "mmcboot=setenv bootargs console=ttyS0,115200
root=/dev/mmcblk0p2 rw rootwait mem=512M;bootz 0x8000 - 0x00000100"
SOCFPGA_CYCLONE5 # env save
Saving Environment to MMC...
Writing to MMC(0)... done
SOCFPGA_CYCLONE5 #
```

Figure 5-22 Save The Setting

- Type **run bootcmd** command to boot the Linux system.
- Login the Linux with root.
- Write the 0x3FFF to 0xFFC25080 with the **memtool** to control the F2H SDRAM interface out of reset as shown in **Figure 5-23**

```
The Angstrom Distribution socfpga ttyS0

Angstrom v2014.12 - Kernel

socfpga login: root
Last login: Mon Mar 13 04:04:03 UTC 2017 on ttyS0
root@socfpga:~# memtool 0xffc25080=0x3fff
Writing 32-bit value 0x3FFF to address 0xFFC25080
root@socfpga:~#
```

Figure 5-23 Take The F2H SDRAM Port Out Of Reset

- Connect another mini-usb cable to the J13 on the DE10-Nano and the host PC for running the **Nios2** code.

- Execute the **test.bat** in the demo_batch folder. The **Nios2** code will run to test the 128M memory start at 0x20000000 in the DDR3 as in **Figure 5-24**.

```
Using cable "DE-SoC [USB-1]", device 2, instance 0x00
Resetting and pausing target processor: OK
Initializing CPU cache (if present)
OK
Downloaded 71KB in 0.1s
Verified OK
Starting processor at address 0x08020244
nios2-terminal: connected to hardware target using JTAG UART on cable
nios2-terminal: "DE-SoC [USB-1]", device 2, instance 0
nios2-terminal: (Use the IDE stop button or Ctrl-C to terminate)

Hello from Nios II!
HPS DDR3 Memory test code
write...
10% 20% 30% 40% 50% 60% 70% 80% 90% 100%
read/verify...
10% 20% 30% 40% 50% 60% 70% 80% 90% 100%
HPS DDR3 test success
```

Figure 5-24 Nios2 Test The DDR3 Memory

Chapter 6

Examples for HPS SoC

This chapter provides several C-code examples based on the Intel SoC Linux built by Yocto project. These examples demonstrate major features of peripherals connected to HPS interface on DE10-Nano board such as users LED/KEY, I2C interfaced G-sensor. All the associated files can be found in the directory Demonstrations/SOC of the DE10-Nano System CD. Please refer to Chapter 5 "**Running Linux on the DE10-Nano board**" from the *Getting_Started_Guide.pdf* to run Linux on DE10-Nano board.

■ Installation of the Demonstrations

To install the demonstrations on the host computer:

Copy the directory *Demonstrations* into a local directory of your choice. [SoC EDS V16.0 is required for users to compile the c-code project.](#)

6.1 Hello Program

This demonstration shows how to develop first HPS program with SoC EDS tool. Please refer to *My_First_HPS.pdf* from the system CD for more details.

The major procedures to develop and build HPS project are:

- Install SoC EDS on the host PC.
- Create program .c/.h files with a generic text editor
- Create a "Makefile" with a generic text editor
- Build the project under SoC EDS

■ Program File

The main program for the Hello World demonstration is:

```
#include <stdio.h>

int main(int argc, char **argv) {
    printf("Hello World!\r\n");
    return( 0 );
}
```

■ Makefile

A Makefile is required to compile a project. The Makefile used for this demo is:

```
#
TARGET = my_first_hps

#
CROSS_COMPILE = arm-linux-gnueabi-
CFLAGS = -g -Wall -I $(SOCEDES_DEST_ROOT)/ip/altera/hps/altera_hps/hwlib/include
LDFLAGS = -g -Wall
CC = $(CROSS_COMPILE)gcc
ARCH= arm

build: $(TARGET)

$(TARGET): main.o
    $(CC) $(LDFLAGS) $^ -o $@

%.o : %.c
    $(CC) $(CFLAGS) -c $< -o $@

.PHONY: clean
clean:
    rm -f $(TARGET) *.a *.o *~
```

■ Compile

Please launch SoC EDS Command Shell to compile a project by executing

EX : C:\altera\16.0\embedded\Embedded_Command_Shell.bat

The "cd" command can change the current directory to where the Hello World project is located. The "make" command will build the project. The executable file "**my_first_hps**" will be generated after the compiling process is successful. The "clean all" command removes all temporary files.

■ Demonstration Source Code

- Build tool: SoC EDS v16.0
- Project directory: \Demonstration\SoC\my_first_hps
- Binary file: my_first_hps
- Build command: make ("**make clean**" to remove all temporary files)
- Execute command: ./my_first_hps

■ Demonstration Setup

- Connect a USB cable to the USB-to-UART connector (J4) on the DE10-Nano board and the host PC.
- Copy the demo file "**my_first_hps**" into a microSD card under the "**/home/root**" folder in Linux.
- Insert the booting microSD card into the DE10-Nano board.
- Power on the DE10-Nano board.
- Launch PuTTY to establish the connection between the UART port of DE10-Dano board and the host PC. Type "root" with the password "terasic" to login LXDE Linux.
- Type "**./my_first_hps**" in the UART terminal of PuTTY to start the program, and the "Hello World!" message will be displayed in the terminal.

```
root@DE10_NANO:~# ./my_first_hps
Hello World!
root@DE10_NANO:~# █
```

6.2 Users LED and KEY

This demonstration shows how to control the users LED and KEY by accessing the register of GPIO controller through the memory-mapped device driver. The memory-mapped device driver allows developer to access the system physical memory.

■ Function Block Diagram

Figure 6-1 shows the function block diagram of this demonstration. The users LED and KEY are connected to the **GPIO1** controller in HPS. The behavior of GPIO controller is controlled by the register in GPIO controller. The registers can be accessed by application software through the memory-mapped device driver, which is built into SoC Linux.

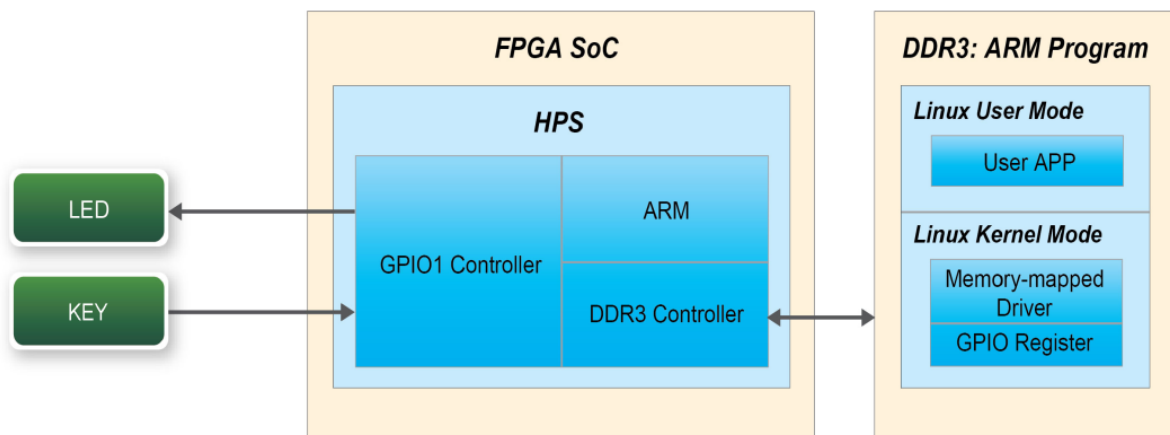

Figure 6-1 Block diagram of GPIO demonstration

■ Block Diagram of GPIO Interface

The HPS provides three general-purpose I/O (GPIO) interface modules. **Figure 6-2** shows the block diagram of GPIO Interface. GPIO[28..0] is controlled by the GPIO0 controller and GPIO[57..29] is controlled by the GPIO1 controller. GPIO[70..58] and input-only GPIO[13..0] are controlled by the GPIO2 controller.

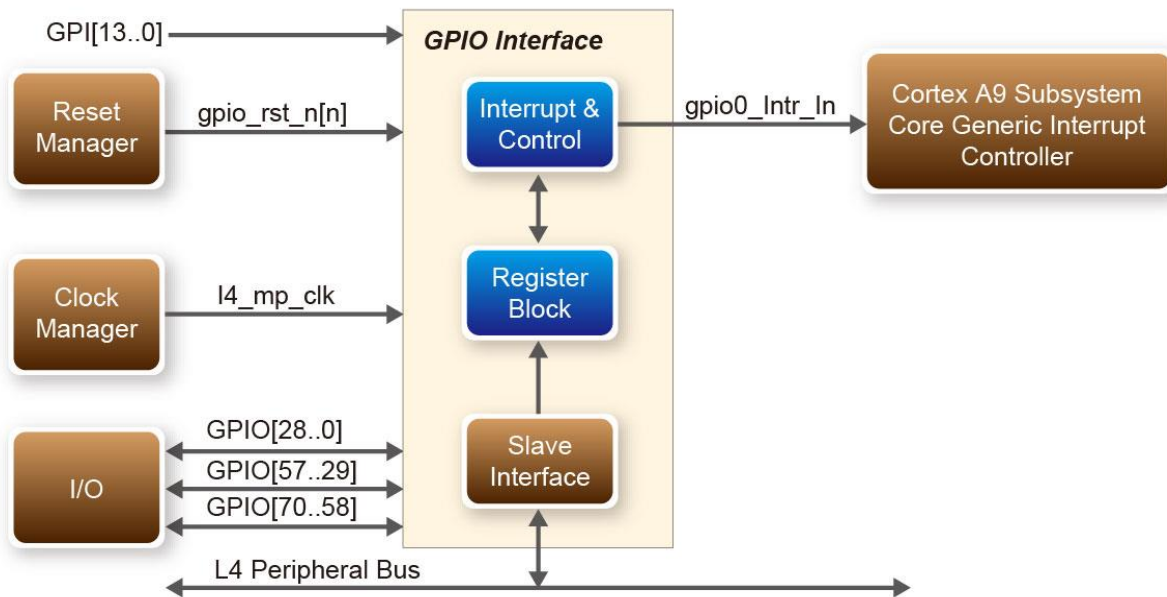

Figure 6-2 Block diagram of GPIO Interface

■ GPIO Register Block

The behavior of I/O pin is controlled by the registers in the register block. There are three 32-bit registers in the GPIO controller used in this demonstration. The registers are:

- **gpio_swporta_dr**: write output data to output I/O pin
- **gpio_swporta_dds**: configure the direction of I/O pin
- **gpio_ext_porta**: read input data of I/O input pin

The **gpio_swporta_dds** configures the LED pin as output pin and drives it high or low by writing data to the **gpio_swporta_dr** register. The first bit (least significant bit) of **gpio_swporta_dr** controls the direction of first IO pin in the associated GPIO controller and the second bit controls the direction of second IO pin in the associated GPIO controller and so on. The value "1" in the register bit indicates the I/O direction is output, while the value "0" in the register bit indicates the I/O direction is input.

The first bit of **gpio_swporta_dr** register controls the output value of first I/O pin in the associated GPIO controller, the second bit controls the output value of second I/O pin in the associated GPIO controller and so on. The value "1" in the register bit indicates the output value is high, and the value "0" indicates the output value is low.

The status of KEY can be queried by reading the value of **gpio_ext_porta** register. The first bit represents the input status of first IO pin in the associated GPIO controller, and the second bit represents the input status of second IO pin in the associated GPIO controller and so on. The value "1" in the register bit indicates the input state is high, and the value "0" indicates the input state is low.

■ GPIO Register Address Mapping

The registers of HPS peripherals are mapped to HPS base address space 0xFC000000 with 64KB size. The registers of the GPIO1 controller are mapped to the base address 0xFF708000 with 4KB size, and the registers of the GPIO2 controller are mapped to the base address 0xFF70A000 with 4KB size, as shown in **Figure 6-3**.

HPS
 Identifier: HPS
 Access: R/W
 Description: Address map for the HHP HPS system-domain

Title	Identifier	Offset
Reserved		0x0
QSPI Flash Controller Module	QSPIREGS	0xFF705000
Register Data		0xFF705100
... Manager Module
ACP ID Mapper Registers	ACPIDMAP	...
GPIO Module	GPIO0	0xFF708000
Reserved		0xFF708080
GPIO Module	GPIO1	0xFF709000
Reserved		0xFF709080
GPIO Module	GPIO2	0xFF70A000
Reserved		0xFF70A080
L3 Cache	...	0xFF800000
...	...	0xFF880000
... AND Controller Module Data (AXI Slave)	NANDE...	...
EMAC Module	EMAC1	0xFF702000

Figure 6-3 GPIO address map

■ Software API

Developers can use the following software API to access the register of GPIO controller.

- open: open memory mapped device driver
- mmap: map physical memory to user space
- alt_read_word: read a value from a specified register
- alt_write_word: write a value into a specified register
- munmap: clean up memory mapping
- close: close device driver.

Developers can also use the following MACRO to access the register

- alt_setbits_word: set specified bit value to one for a specified register
- alt_clrbits_word: set specified bit value to zero for a specified register

The program must include the following header files to use the above API to access the registers of GPIO controller.

```
#include <stdio.h>

#include <unistd.h>

#include <fcntl.h>

#include <sys/mman.h>

#include "hwlib.h"

#include "social/social.h"

#include "social/hps.h"

#include "social/alt_gpio.h"
```

■ LED and KEY Control

Figure 6-4 shows the HPS users LED and KEY pin assignment for the DE10-Nano board. The LED is connected to HPS_GPIO53 and the KEY is connected to HPS_GPIO54. They are controlled by the GPIO1 controller, which also controls HPS_GPIO29 ~ HPS_GPIO57.

HPS_GPIO53	A20	HPS_LED
HPS_GPIO54	J18	HPS_KEY

Figure 6-4 Pin assignment of LED and KEY

Figure 6-5 shows the `gpio_swporta_ddr` register of the GPIO1 controller. The bit-0 controls the pin direction of HPS_GPIO29. The bit-24 controls the pin direction of HPS_GPIO53, which connects to HPS_LED, the bit-25 controls the pin direction of HPS_GPIO54, which connects to HPS_KEY, and so on. The pin direction of HPS_LED and HPS_KEY are controlled by the bit-24 and bit-25 in the `gpio_swporta_ddr` register of the GPIO1 controller, respectively. Similarly, the output status of HPS_LED is controlled by the bit-24 in the `gpio_swporta_dr` register of the GPIO1 controller. The status of KEY can be queried by reading the value of the bit-24 in the `gpio_ext_porta` register of the GPIO1 controller.

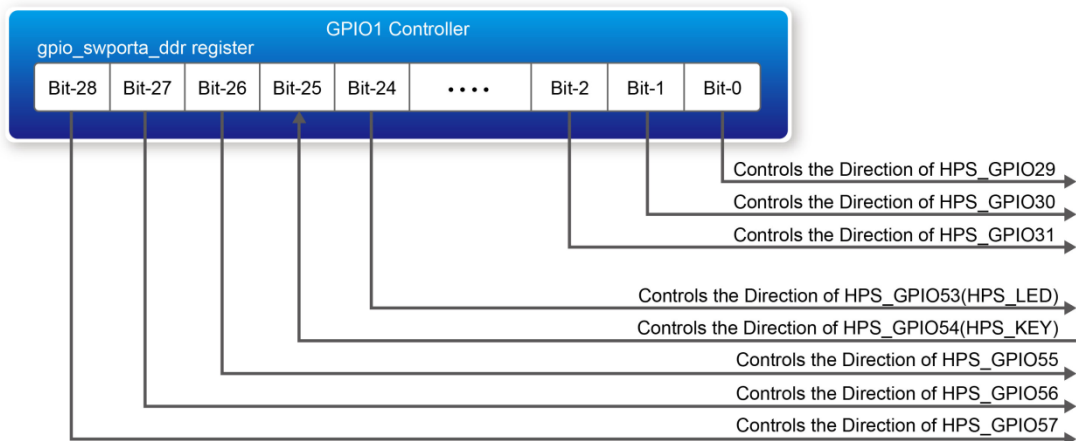

Figure 6-5 gpio_swporta_ddr register in the GPIO1 controller

The following mask is defined in the demo code to control LED and KEY direction and LED's output value.

```
#define USER_IO_DIR      (0x01000000)

#define BIT_LED          (0x01000000)

#define BUTTON_MASK     (0x02000000)
```

The following statement is used to configure the LED associated pins as output pins.

```
alt_setbits_word(          (          virtual_base      +
( ( uint32_t )( ALT_GPIO1_SWPORTA_DDR_ADDR ) &
( uint32_t )( HW_REGS_MASK ) ), USER_IO_DIR );
```

The following statement is used to turn on the LED.

```
alt_setbits_word(          (          virtual_base      +
( ( uint32_t )( ALT_GPIO1_SWPORTA_DR_ADDR ) &
( uint32_t )( HW_REGS_MASK ) ), BIT_LED );
```

The following statement is used to read the content of **gpio_ext_porta** register. The bit mask is used to check the status of the key.

```
alt_read_word(          (          virtual_base      +
( ( uint32_t )( ALT_GPIO1_EXT_PORTA_ADDR ) &
( uint32_t )( HW_REGS_MASK ) ));
```

■ Demonstration Source Code

- Build tool: SoC EDS V16.0
- Project directory: \Demonstration\SoC\hps_gpio
- Binary file: hps_gpio
- Build command: make ('make clean' to remove all temporal files)
- Execute command: ./hps_gpio

■ Demonstration Setup

- Connect a USB cable to the USB-to-UART connector (J4) on the DE10-Nano board and the host PC.
- Copy the executable file "**hps_gpio**" into the microSD card under the "**/home/root**" folder in Linux.
- Insert the booting micro SD card into the DE10-Nano board.
- Power on the DE10-Nano board.
- Launch PuTTY to establish the connection between the UART port of DE10-Dano board and the host PC. Type "root" with the password "terasic" to login LXDE Linux.
- Type "**./hps_gpio**" in the UART terminal of PuTTY to start the program.

```
root@DE10_NANO:~# ./hps_gpio
led test
the led flash 2 times
user key test
press key to control led
```

- HPS_LED will flash twice and users can control the user LED with push-button.
- Press HPS_KEY to light up HPS_LED.
- Press "CTRL + C" to terminate the application.

6.3 I2C Interfaced G-sensor

This demonstration shows how to control the G-sensor by accessing its registers through the built-in I2C kernel driver in Linux BSP.

■ Function Block Diagram

Figure 6-6 shows the function block diagram of this demonstration. The G-sensor on the DE10-Nano board is connected to the **I2C0** controller in HPS. The G-Sensor I2C 7-bit device address is 0x53. The system I2C bus driver is used to access the register files in the G-sensor. The G-sensor interrupt signal is connected to the PIO controller. This demonstration uses polling method to read the register data.

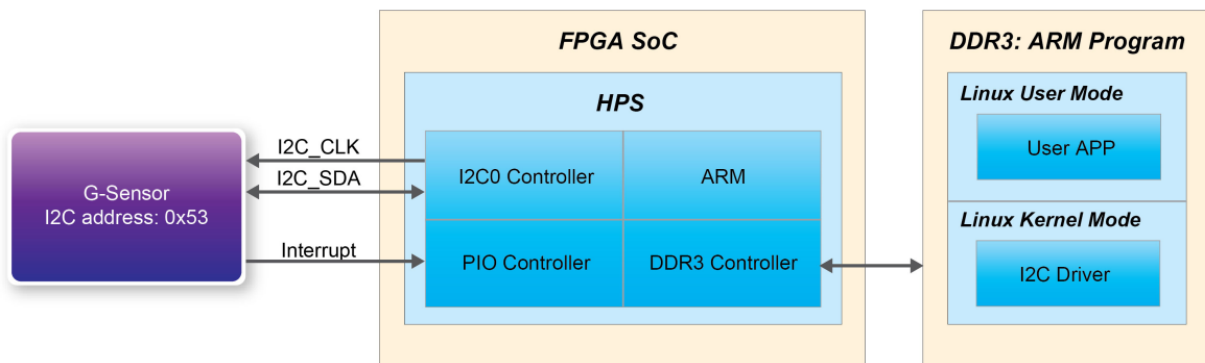

Figure 6-6 Block diagram of the G-sensor demonstration

■ I2C Driver

The procedures to read a register value from G-sensor register files by the existing I2C bus driver in the system are:

1. Open I2C bus driver `"/dev/i2c-0"`: `file = open("/dev/i2c-0", O_RDWR);`
2. Specify G-sensor's I2C address 0x53: `ioctl(file, I2C_SLAVE, 0x53);`
3. Specify desired register index in g-sensor: `write(file, &Addr8, sizeof(unsigned char));`
4. Read one-byte register value: `read(file, &Data8, sizeof(unsigned char));`

The G-sensor I2C bus is connected to the I2C0 controller, as shown in the **Figure 6-7**. The driver name given is '/dev/i2c-0'.

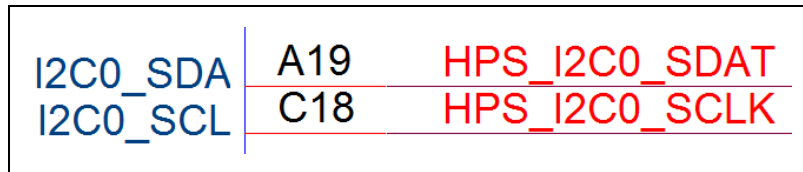

Figure 6-7 Connection of HPS I2C signals

The step 4 above can be changed to the following to write a value into a register.

```
write(file, &Data8, sizeof(unsigned char));
```

The step 4 above can also be changed to the following to read multiple byte values.

```
read(file, &szData8, sizeof(szData8)); // where szData is an array of bytes
```

The step 4 above can be changed to the following to write multiple byte values.

```
write(file, &szData8, sizeof(szData8)); // where szData is an array of bytes
```

■ G-sensor Control

The ADI ADXL345 provides I2C and SPI interfaces. I2C interface is selected by setting the CS pin to high on the DE10-Nano board.

The ADI ADXL345 G-sensor provides user-selectable resolution up to 13-bit $\pm 16g$. The resolution can be configured through the DATA_FORMAT(0x31) register. The data format in this demonstration is configured as:

- Full resolution mode
- $\pm 16g$ range mode
- Left-justified mode

The X/Y/Z data value can be derived from the DATA0(0x32), DATA1(0x33), DATAY0(0x34), DATAY1(0x35), DATAZ0(0x36), and DATAZ1(0x37) registers. The DATA0 represents the least significant byte and the DATA1 represents the most significant byte. It is recommended to perform multiple-byte read of all registers to prevent change in data between sequential registers read. The following statement reads 6 bytes of X, Y, or Z value.

```
read(file, szData8, sizeof(szData8)); // where szData is an array of six-bytes
```

■ Demonstration Source Code

- Build tool: SoC EDS v16.0
- Project directory: \Demonstration\SoC\hps_gsensor
- Binary file: gsensor
- Build command: make ('make clean' to remove all temporal files)
- Execute command: ./gsensor [loop count]

■ Demonstration Setup

- Connect a USB cable to the USB-to-UART connector (J4) on the DE10-Nano board and the host PC.
- Copy the executable file "**gsensor**" into the microSD card under the "**/home/root**" folder in Linux.
- Insert the booting microSD card into the DE10-Nano board.
- Power on the DE10-Nano board.
- Launch PuTTY to establish the connection between the UART port of DE10-Dano board and the host PC. Type "root" with the password "terasic" to login LXDE Linux.
- Execute "**./gsensor**" in the UART terminal of PuTTY to start the G-sensor polling.
- The demo program will show the X, Y, and Z values in the PuTTY, as shown in **Figure 6-8**.

```
root@DE10_NANO:~# chmod +x gsensor
root@DE10_NANO:~# ./gsensor
===== gsensor test =====
id=E5h
[1]X=12 mg, Y=-32 mg, Z=908 mg
[2]X=12 mg, Y=-28 mg, Z=964 mg
[3]X=12 mg, Y=-28 mg, Z=964 mg
[4]X=8 mg, Y=-32 mg, Z=960 mg
[5]X=12 mg, Y=-32 mg, Z=960 mg
```

Figure 6-8 Terminal output of the G-sensor demonstration

- Press "CTRL + C" to terminate the program.

6.4 Setup USB Wi-Fi Dongle

This section describes how to setup the Wi-Fi USB dongle under Linux, so Linux user can wirelessly connect to the Wi-Fi AP (Access Point) through the Wi-Fi USB Dongle and finally connect to the internet. The Wi-Fi AP is assumed to have the DHCP server capability and is connected to the internet. You should also make sure you know the SSID and Password of the Wi-Fi AP.

■ System Diagram

Figure 6-9 shows the block diagram of this demonstration. The Wi-Fi AP assumes you have the DHCP server capability and is connected to the LAN (Local Area Network) or the internet. The USB Wi-Fi Dongle connects to the Wi-Fi AP and gets an address IP from the Wi-Fi AP. Through the Wi-Fi AP, the USB-Dongle will be able to communicate with the devices connected to the LAN or the internet.

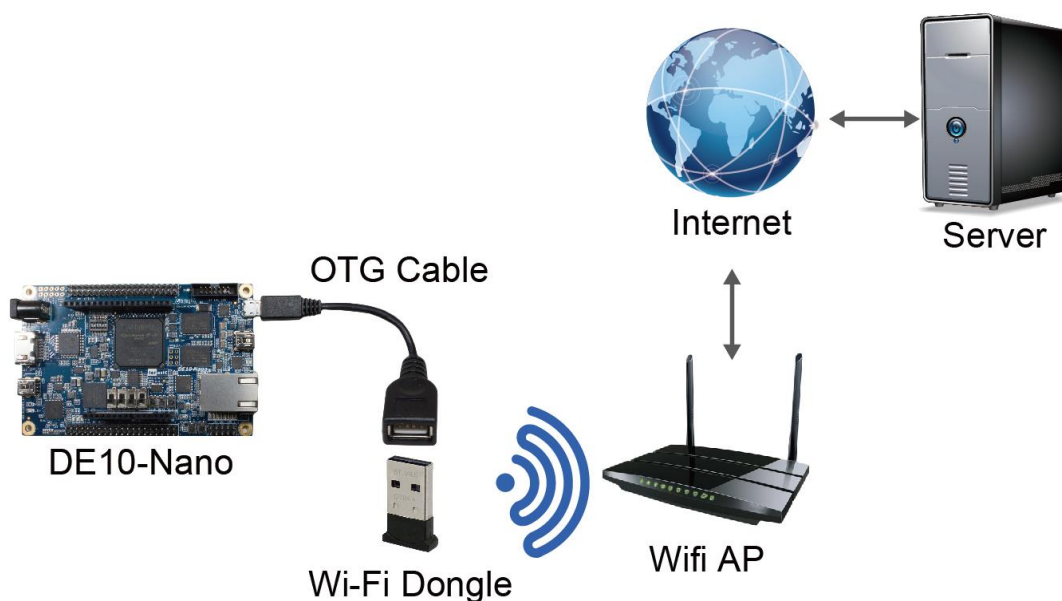

Figure 6-9 System diagram of USB Wi-Fi dongle

■ Wi-Fi Setup Procedure

- Connect a USB cable to the USB-to-UART connector (J4) on the DE10-Nano board and the host PC.
- Use a USB OTG cable to connect the USB Wi-Fi Dongle and the micro USB port on the DE10-Nano.
- Power on the DE10-Nano board.
- Launch PuTTY to establish the connection between the UART port of the DE10-Nano

board and the host PC. Type "root" with the password "terasic" to login to the LXDE Linux.

- Type "**ifconfig wlan0 up**" in the UART terminal of PuTTY to start wlan0 network interface.
- Type "**iwlist wlan0 scan | grep ESSID**" in the UART terminal to search nearby Wi-Fi AP. Make sure your Wi-Fi AP is found.

```
# iwlist wlan0 scan | grep ESSID
ESSID: " "
ESSID: " "
ESSID: " "
ESSID: " "
ESSID: " "
ESSID: " "
ESSID: " "
ESSID: " "
ESSID: " "
ESSID: " "
ESSID: " "
ESSID: " "
ESSID: " "
ESSID: "Terasic"
ESSID: " "
```

- Type "**vim /etc/wpa_supplicant/wpa_supplicant.conf**" in the UART terminal to edit Wi-Fi configuration file.

```
ctrl_interface=/var/run/wpa_supplicant

network={
    ssid="Your_SSID"
    psk="Your_WPA-Key_ASCII"
}
```

- In the configuration file, replace "Your_SSID" and "Your_WPA-Key_ASCII" with the SSID and password for your Wi-Fi AP, in respectively.

```
ctrl_interface=/var/run/wpa_supplicant

network={
    ssid="Terasic"
    psk="1234567890"
}
```

- Type "**ifup wlan0**" in the UART terminal to connect to the Wi-Fi AP.

```
root@DE10_NANO:~# ifup wlan0
Internet Systems Consortium DHCP Client 4.3.3
Copyright 2004-2015 Internet Systems Consortium.
All rights reserved.
For info, please visit https://www.isc.org/software/dhcp/

Listening on LPF/wlan0/f0:b4:29:3c:eb:7a
Sending on LPF/wlan0/f0:b4:29:3c:eb:7a
Sending on Socket/fallback
DHCPREQUEST of 192.168.2.4 on wlan0 to 255.255.255.255 port 67 (xid=0x4ec4a270)
DHCPREQUEST of 192.168.2.4 on wlan0 to 255.255.255.255 port 67 (xid=0x4ec4a270)
DHCPNAK from 192.168.2.1 (xid=0x70a2c44e)
DHCPDISCOVER on wlan0 to 255.255.255.255 port 67 interval 3 (xid=0xf0a0b660)
DHCPREQUEST of 192.168.2.2 on wlan0 to 255.255.255.255 port 67 (xid=0x60b6a0f0)
DHCPOFFER of 192.168.2.2 from 192.168.2.1
DHCPACK of 192.168.2.2 from 192.168.2.1
bound to 192.168.2.2 -- renewal in 33561 seconds.
```

- Type "**ifconfig wlan0**" in the UART terminal to confirm an IP Address is assigned to wlan0 interface.

```
root@DE10_NANO:~# ifconfig wlan0
wlan0      Link encap:Ethernet  HWaddr f0:b4:29:3c:eb:7a
           inet addr:192.168.2.2   Bcast:192.168.2.255  Mask:255.255.255.0
           inet6 addr: fe80::f2b4:29ff:fe3c:eb7a/64 Scope:Link
           UP BROADCAST RUNNING MULTICAST  MTU:1500  Metric:1
           RX packets:15 errors:0 dropped:0 overruns:0 frame:0
           TX packets:21 errors:0 dropped:0 overruns:0 carrier:0
           collisions:0 txqueuelen:1000
           RX bytes:3620 (3.6 KB)  TX bytes:2840 (2.8 KB)
```

- Make sure Wi-Fi AP is connected to the internet. Type "**ping -c 4 www.terasic.com**" in the UART terminal to check internet connection status. If 0% packet loss is reported, it means the connection is good.

```
root@DE10_NANO:~# ping -c 4 www.terasic.com
PING www.terasic.com (192.254.233.22) 56(84) bytes of data.
64 bytes from www.terasic.com (192.254.233.22): icmp_seq=1 ttl=48 time=180 ms
64 bytes from www.terasic.com (192.254.233.22): icmp_seq=2 ttl=48 time=173 ms
64 bytes from www.terasic.com (192.254.233.22): icmp_seq=3 ttl=48 time=184 ms
64 bytes from www.terasic.com (192.254.233.22): icmp_seq=4 ttl=48 time=230 ms

--- www.terasic.com ping statistics ---
4 packets transmitted, 4 received, 0% packet loss, time 3004ms
rtt min/avg/max/mdev = 173.816/192.296/230.276/22.260 ms
```

6.5 Query Internet Time

This demonstration shows how clients use timing web server and query the internet time through Internet. The time information will be shown on the UART terminal with the format HH:MM:SS. The DE10-Nano connects to Ethernet through wire RJ45 Port or wireless Wi-Fi USB-Dongle. For details about how to setup the Wi-Fi USB-Dongle, please refer to the chapter [6.4 Setup USB Wi-Fi Dongle](#).

■ Function Block Diagram

Figure 6-10 shows the function block diagram of the Query Internet Time. A free third-party library **libcurl** is to handle URL transfer tasks. The main program uses "http get" request to query web content and directly display the response content on the NIOS II terminal.

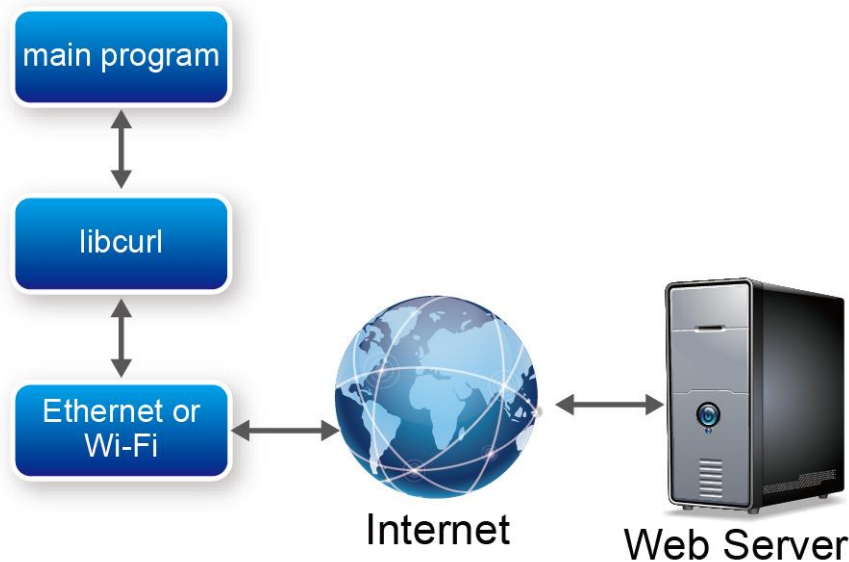

Figure 6-10 Function block diagram of Internet Time demonstration

■ URL transfer library: libcurl

The **libcurl** library is designed for the client site of the network. The library implements complex internet protocol but provides simple C API for developers. The developers for client program can easily communicate to the server by calling the API exported in the library.

For details, please refer to <https://curl.haxx.se/libcurl/>

■ How to Query Internet Time

The internet time information is available at <http://demo.terasic.com>. Sending URL <http://demo.terasic.com/time/> to the web server, it will respond with current time in the following format HH:MM:SS.

■ Demonstration Source Code

- Build tool: SoC EDS V16.0
- Project directory: \Demonstration\SoC_Advanced\NET_Time
- Binary file: NET_Time
- Build command: make ('make clean' to remove all temporal files)
- Execute command: ./NET_Time

■ Demonstration Setup

- Connect a USB cable to the USB-to-UART connector (J4) on the DE10-Nano board and the host PC.
- Copy the executable file "**NET_Time**" into the microSD card under the **"/home/root"** folder in Linux.
- Insert the booting micro SD card into the DE10-Nano board.
- Power on the DE10-Nano board.
- Launch PuTTY to establish the connection between the UART port of DE10-Nano board and the host PC. Type "root" with the password "terasic" to login LXDE Linux.
- Type **"./NET_Time"** in the UART terminal of PuTTY to start the program.

```
root@DE10_NANO:~# ./NET_Time
06:24:28
```

- The UTC(Universal Time Coordinated) time will be display on the UART terminal.
- Press "CTRL + C" to terminate the application.

Chapter 7

Examples for using both HPS SoC and FPGA

This Chapter demonstrates how to use the HPS/ARM to communicate with FPGA. We will introduce the GHRD project for DE10-Nano development board. And we develop one ARM C Project which demonstrates how HPS/ARM program controls the green LEDs connected to FPGA. We will shows how HPS controls the FPGA LED through Lightweight HPS-to-FPGA Bridge. The FPGA is configured by HPS through FPGA manager in HPS.

7.1 Required Background

This section pre-assumed the developers have the following background knowledge:

■ FPGA RTL Design

- Basic Quartus II operation skill
- Basic RTL coding skill
- Basic Qsys operation skill
- Knowledge about Memory-Mapped Interface

■ C Program Design

- Basic SoC EDS(Embedded Design Suite) operation skill
- Basic C coding and compiling skill
- Skill to Create a Linux Boot SD-Card for DE10-Nano with a given image file
- Skill to boot Linux from SD-Card on DE10-Nano Skill to cope files into Linux file system on DE10-Nano Basic Linux command operation skill

7.2 System Requirements

Before starting this tutorial, please note that the following items are required to complete the demonstration project:

■ Terasic DE10-Nano FPGA board, includes

- Mini USB Cable for UART terminal
- Micros SD-Card, at 4GB minimum
- Micros SD-Card Card Reader

■ A x86 PC

- Windows 7 64 bit operation system Installed
- One USB Port
- Quartus II 16.0 or Later Installed
- SoC EDS 16.0 or Later Installed
- Win32 Disk Imager Installed

7.3 AXI bridges in Intel SoC FPGA

In Intel SoC FPGA, the HPS logic and FPGA fabric are connected through the AXI (Advanced eXtensible Interface) bridge. For HPS logic to communicate with FPGA fabric, Intel system integration tool **Qsys** should be used for the system design to add **HPS** component. From the AXI master port of the HPS component, HPS can access those Qsys components whose memory-mapped slave ports are connected to the master port.

The HPS contains the following HPS-FPGA AXI bridges.

- FPGA-to-HPS Bridge
- HPS-to-FPGA Bridge
- Lightweight HPS-to-FPGA Bridge

Figure 7-1 shows a block diagram of the AXI bridges in the context of the FPGA fabric and the L3 interconnect to the HPS. Each master (M) and slave (S) interface is shown with its data width(s). The clock domain for each interconnect is noted in parentheses.

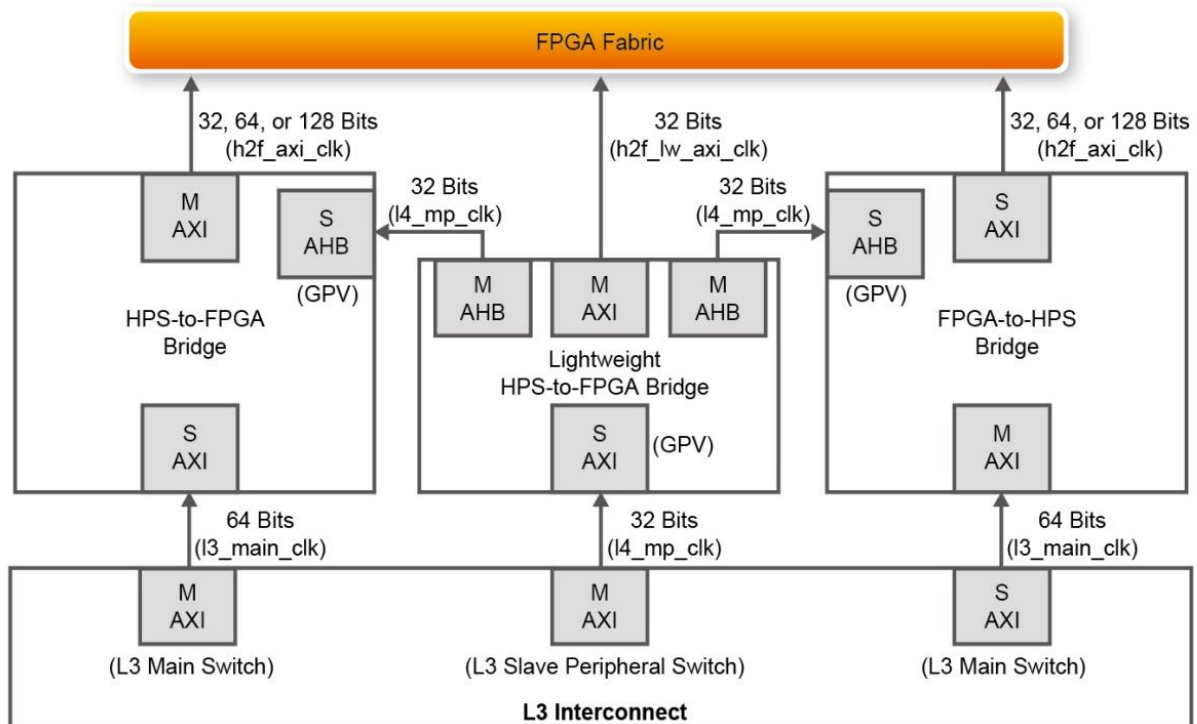

Figure 7-1 AXI Bridge Block Diagram

The HPS-to-FPGA bridge is mastered by the level 3 (L3) main switch and the lightweight HPS-to-FPGA bridge is mastered by the L3 slave peripheral switch.

The FPGA-to-HPS bridge masters the L3 main switch, allowing any master implemented in the FPGA fabric to access most slaves in the HPS. For example, the FPGA-to-HPS bridge can access the accelerator coherency.

All three bridges contain global programmer view GPV register. The GPV register control the behavior of the bridge. It is able to access to the GPV registers of all three bridges through the lightweight HPS-to-FPGA bridge.

This Demo introduces to users how to use the HPS/ARM to communicate with FPGA. This project includes GHRD project for the DE10-Nano one ARM C Project which demonstrates how HPS/ARM program controls the green LEDs connected to FPGA.

7.4 GHRD Project

The term GHRD is short for Golden Hardware Reference Design. The GRD project provide by Terasic for the DE10-Nano development board is located in the CD folder: CD-ROM\Demonstration\SOC_FPGA\DE10_NANO_SoC_GHRD.

The project consists of the following components:

- ARM Cortex™-A9 MPCore HPS
- Two user push-button inputs
- Four user DIP switch inputs
- Seven user I/O for LED outputs
- JTAG to Avalon master bridges
- Interrupt capturer for use with System Console
- System ID

The memory map of system peripherals in the FPGA portion of the SoC as viewed by the MPU starts at the lightweight HPS-to-FPGA base address 0xFF20_0000. The MPU can access these peripherals through the Address offset setting in the Qsys. User can open the GHRD project with Quartus II Software. Then open the soc_system.qsys file with the Qsys tool. **Figure 7-2** lists the address map of the peripherals which are connected to the lightweight HPS-to-FPGA.

System: soc_system Path: button_pio	
	mm_bridge_0.m0
sysid_qsys.control_slave	0x0000_1000 - 0x0000_1007
jtag_uart.avalon_jtag_slave	0x0000_2000 - 0x0000_2007
led_pio.s1	0x0000_3000 - 0x0000_300f
dipsw_pio.s1	0x0000_4000 - 0x0000_400f
button_pio.s1	0x0000_5000 - 0x0000_500f
ILC.avalon_slave	0x0003_0000 - 0x0003_00ff
hps_0.f2h_stream0_data	
hps_0.f2h_axi_slave	
mm_bridge_0.s0	
ILC.avalon_slave via mm_bridge_0	
jtag_uart.avalon_jtag_slave via mm_brid...	
dipsw_pio.s1 via mm_bridge_0	
sysid_qsys.control_slave via mm_bridge...	
led_pio.s1 via mm_bridge_0	
button_pio.s1 via mm_bridge_0	

Figure 7-2 FPGA peripherals address map

All the Avalon Conduit signals of these peripherals are connected to the I/O pins of the SoCFPGA on DE10-Nano board as shown in the **Figure 7-3**.

```

//HPS SPI
.hps_0_hps_io_hps_io_spim1_inst_CLK ( HPS_SPIM_CLK ), // .hps_io_spim1_inst_CLK
.hps_0_hps_io_hps_io_spim1_inst_MOSI ( HPS_SPIM_MOSI ), // .hps_io_spim1_inst_MOSI
.hps_0_hps_io_hps_io_spim1_inst_MISO ( HPS_SPIM_MISO ), // .hps_io_spim1_inst_MISO
.hps_0_hps_io_hps_io_spim1_inst_SS0 ( HPS_SPIM_SS ), // .hps_io_spim1_inst_SS0
//HPS UART
.hps_0_hps_io_hps_io_uart0_inst_RX ( HPS_UART_RX ), // .hps_io_uart0_inst_RX
.hps_0_hps_io_hps_io_uart0_inst_TX ( HPS_UART_TX ), // .hps_io_uart0_inst_TX
//HPS I2C1
.hps_0_hps_io_hps_io_i2c0_inst_SDA ( HPS_I2C0_SDAT ), // .hps_io_i2c0_inst_SDA
.hps_0_hps_io_hps_io_i2c0_inst_SCL ( HPS_I2C0_SCLK ), // .hps_io_i2c0_inst_SCL
//HPS I2C2
.hps_0_hps_io_hps_io_i2c1_inst_SDA ( HPS_I2C1_SDAT ), // .hps_io_i2c1_inst_SDA
.hps_0_hps_io_hps_io_i2c1_inst_SCL ( HPS_I2C1_SCLK ), // .hps_io_i2c1_inst_SCL
//GPIO
.hps_0_hps_io_hps_io_gpio_inst_GPIO09 ( HPS_CONV_USB_N ), // .hps_io_gpio_inst_GPIO09
.hps_0_hps_io_hps_io_gpio_inst_GPIO35 ( HPS_ENET_INT_N ), // .hps_io_gpio_inst_GPIO35
.hps_0_hps_io_hps_io_gpio_inst_GPIO40 ( HPS_LTC_GPIO ), // .hps_io_gpio_inst_GPIO40
.hps_0_hps_io_hps_io_gpio_inst_GPIO53 ( HPS_LED ), // .hps_io_gpio_inst_GPIO53
.hps_0_hps_io_hps_io_gpio_inst_GPIO54 ( HPS_KEY ), // .hps_io_gpio_inst_GPIO54
.hps_0_hps_io_hps_io_gpio_inst_GPIO61 ( HPS_GSENSOR_INT ), // .hps_io_gpio_inst_GPIO61
//FPGA Partition
.led_pio_external_connection_export ( fpga_led_internal ), // led_pio_external_connection.export
.dipsw_pio_external_connection_export ( SW ), // dipsw_pio_external_connection.export
.button_pio_external_connection_export ( fpga_debounced_buttons ), // button_pio_external_connection.export
.hps_0_h2t_reset_reset_n ( hps_fpga_reset_n ), // hps_0_h2t_reset_reset_n
.hps_0_f2h_cold_reset_req_reset_n ( -hps_cold_reset ), // hps_0_f2h_cold_reset_req_reset_n
.hps_0_f2h_debug_reset_req_reset_n ( -hps_debug_reset ), // hps_0_f2h_debug_reset_req_reset_n
.hps_0_f2h_stm_hw_events_stm_hwevents ( stm_hw_events ), // hps_0_f2h_stm_hw_events.stm_hwevents
.hps_0_f2h_warm_reset_req_reset_n ( -hps_warm_reset ), // hps_0_f2h_warm_reset_req_reset_n

```

Figure 7-3 Connection in the top design

7.5 Compile and Programming

In the Qsys tool, click the menu item “Generate→Generate...” to generate source code for the system and then close the Qsys tool. Now, users can start the compile process by clicking the menu item “Processing→Start Compilation”.

Because .tcl files of SDRAM DDR3 controller for HPS had been executed in GHRD project, developers can skip this procedure. If developers’ Quartus project is not developed based on the GHRD project, please remember to execute the .tcl files of SDRAM DDR3 controller, as show in **Figure 7-4**, before executing ‘Start Compilation’.

The TCL Scripts dialog can be launched by clicking the menu item “Tools→TCL Scripts...”. <qsys_system_name>_parameters.tcl and <qsys_system_name>_pin_assignments.tcl tcl files should be executed, where <qsys_system_name> is the name of your Qsys system. Run this script to assign constrains for the SDRAM DDR3 component.

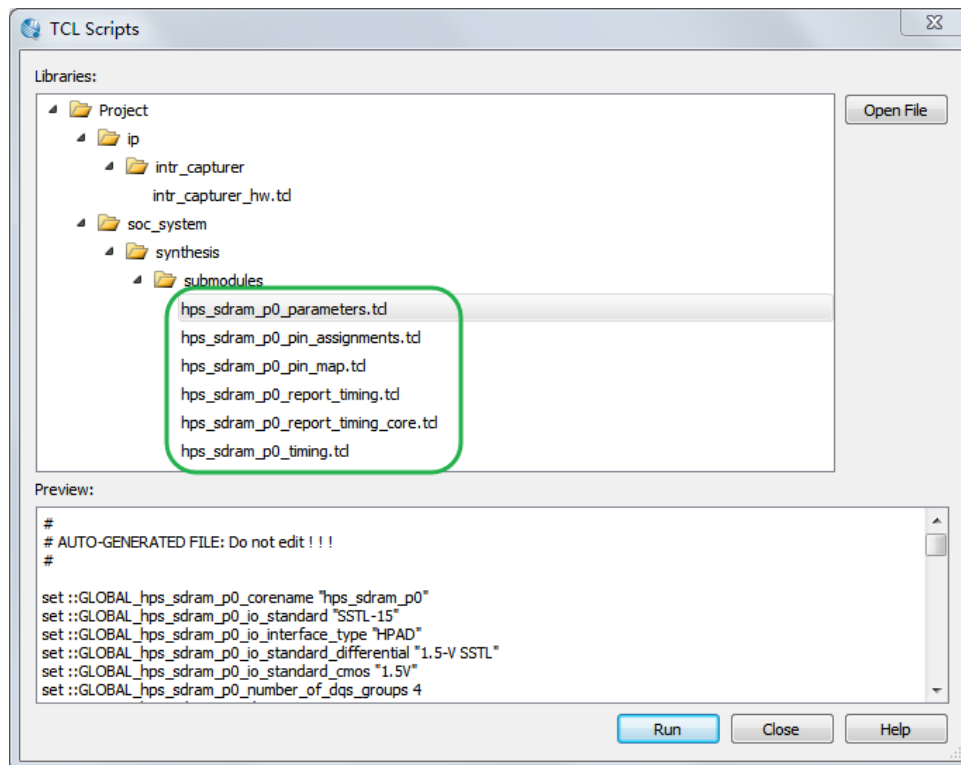

Figure 7-4 Running the SDRAM Controller tcl

Now, users can start the compile process by clicking the menu item “Processing→Start Compilation”. When the compilation process is completed successfully, **DE10_NANO_SoC_GHRD.sof** is generated in the DE10_NANO_SoC_GHRD/output_files folder. Users can use this file to configure FPGA by Quartus Programming through the DE10-Nano on-board USB-Blaster II.

7.6 Develop the C Code

This section introduces how to design an ARM C program to control the **led_pio** PIO controller. SoC EDS is used to compile the C project. For ARM program to control the **led_pio** PIO component, **led_pio** address is required. The Linux built-in driver ‘/dev/mem’ and mmap system-call are used to map the physical base address of **led_pio** component to a virtual address which can be directly accessed by Linux application software.

■ HPS Header File

pio_led component information is required for ARM C program as the program will attempt to control the component. This section describes how to use a given Linux shell batch file to extract the Qsys HPS information to a header file which will be included in the C program later.

The batch file mentioned above is called as **generate_hps_qsys_header.sh**. It is located in the same folder as DE10_NANO_SoC_GHRD Quartus project. To generate the header file, launch SoC EDS command shell, go to the Quartus project folder, and execute **generate_hps_qsys_header.sh** by typing **./generate_hps_qsys_header.sh**. Then, press ENTER key, a header file **hps_0.h** will be generated. In the header file, the **led_pio** base address is represented by a constant **LED_PIO_BASE** as show in **Figure 7-5**. The **led_pio** width is represented by a constant **LED_PIO_DATA_WIDTH**. These two constants will be used in the C program demonstration code.

```

/*
 * Macros for device 'led_pio', class 'altera_avalon_pio'
 * The macros are prefixed with 'LED_PIO_'.
 * The prefix is the slave descriptor.
 */
#define LED_PIO_COMPONENT_TYPE altera_avalon_pio
#define LED_PIO_COMPONENT_NAME led_pio
#define LED_PIO_BASE 0x3000
#define LED_PIO_SPAN 16
#define LED_PIO_END 0x300f
#define LED_PIO_BIT_CLEARING_EDGE_REGISTER 0
#define LED_PIO_BIT_MODIFYING_OUTPUT_REGISTER 0
#define LED_PIO_CAPTURE 0
#define LED_PIO_DATA_WIDTH 7
#define LED_PIO_DO_TEST_BENCH_WIRING 0
#define LED_PIO_DRIVEN_SIM_VALUE 0
#define LED_PIO_EDGE_TYPE NONE
#define LED_PIO_FREQ 50000000
#define LED_PIO_HAS_IN 0
#define LED_PIO_HAS_OUT 1
#define LED_PIO_HAS_TRI 0
#define LED_PIO_IRQ_TYPE NONE
#define LED_PIO_RESET_VALUE 127

```

Figure 7-5 pio_led information defined in hps_0.h

■ Map LED_PIO Address

This section will describe how to map the **pio_led** physical address into a virtual address which is accessible by an application software. **Figure 7-6** shows the C program to derive the virtual address of **led_pio** base address. First, **open** system-call is used to open memory device driver **"/dev/mem"**, and then the **mmap** system-call is used to map HPS physical address into a virtual address represented by the void pointer variable **virtual_base**. The demo code maps the physical base address (**HW_REGS_BASE = 0xfc000000**) of the peripheral region into a based virtual address **virtual_base**. For any controller in the peripheral region, users can calculate their virtual address by adding their offset relative to the peripheral region to the based virtual address **virtual_base**. Based on the rule, the virtual address of **led_pio** can be calculated by adding the below two offset addresses to **virtual_base**.

- Offset address of Lightweight HPS-to-FPGA AXI bus relative to HPS base address
- Offset address of Pio_led relative to Lightweight HPS-to-FPGA AXI bus

The first offset address is 0xff200000 which is defined as a constant ALT_LWFPGASLVS_OFST in the header hps.h. The hps.h is a header of SoC EDS. It is located in the Quartus installation folder: D:\altera\embedded\ip\altera\hps\altera_hps\hwlib\include\soc_cv_av\socal

The second offset address is 0x3000 which is defined as LED_PIO_BASE in the hps_0.h header file which is generated in above section.

The virtual address of pio_led is represented by a void pointer variable **h2p_lw_led_addr**.

Application program can directly use the pointer variable to access the registers in the controller of **LED_PIO**.

```
if ( fd = open( "/dev/mem", ( O_RDWR | O_SYNC ) ) == -1 ) {
    printf( "ERROR: could not open \"/dev/mem\"...\n" );
    return( 1 );
}

virtual_base = mmap( NULL, HW_REGS_SPAN, ( PROT_READ | PROT_WRITE ), MAP_SHARED, fd, HW_REGS_BASE );

if( virtual_base == MAP_FAILED ) {
    printf( "ERROR: mmap() failed...\n" );
    close( fd );
    return( 1 );
}

h2p_lw_led_addr=virtual_base + ( ( unsigned long )( ALT_LWFPGASLVS_OFST + LED_PIO_BASE ) & ( unsigned long)( HW_REGS_MASK ) );
```

Figure 7-6 LED_PIO memory map code

■ LED Control

C programmers need to understand the Register Map of the PIO core for **LED_PIO** before they can control it. **Figure 7-7** shows the Register Map for the PIO Core. Each register is 32-bit width. For detail information, please refer to the datasheet of PIO Core. For led control, we just need to write output value to the offset 0 register relative to based address 0x3000. Because the led on DE10-Nano is high active, writing a value 0x00000000 to the offset 0 register will turn off all of the eight green LEDs. There are 8 green LEDs on DE10-Dano and 7 of them are connected to this controller. The last LED (LED0) is used to implement FPGA heartbeat. Writing a value 0x000000ff to the offset 0 register will turn on all of seven green LEDs. In C program, writing a value 0x0000007f to the offset 0 register of pio_led can be implemented as:

```
*(uint32_t *) h2p_lw_led_addr= 0x0000007f;
```

The state will assign the void pointer to a uint32_t pointer, so C compiler knows write a 32-bit value 0x0000007f to the virtual address h2p_lw_led_addr.

Offset	Register Name		R/W	Fields				
				(n-1)	...	2	1	0
0	data	read access	R	Data value currently on PIO inputs.				
		write access	W	New value to drive on PIO outputs.				
1	direction (1)		R/W	Individual direction control for each I/O port. A value of 0 sets the direction to input; 1 sets the direction to output.				
2	interruptmask (1)		R/W	IRQ enable/disable for each input port. Setting a bit to 1 enables interrupts for the corresponding port.				
3	edgecapture (1), (2)		R/W	Edge detection for each input port.				
4	outset		W	Specifies which bit of the output port to set.				
5	outclear		W	Specifies which output bit to clear.				

Figure 7-7 Register Map of PIO Core

■ Main Program

In the main program, the LED is controlled to perform LED light sifting operation as shown in Figure 7-8. When finishing 60 times of shift cycle, the program will be terminated.

```

loop_count = 0;
led_mask = 0x01;
led_direction = 0; // 0: left to right direction
while( loop_count < 60 ) {

    // control led, add ~ because the led is low-active
    *(uint32_t *)h2p_lw_led_addr = ~led_mask;

    // wait 100ms
    usleep( 100*1000 );

    // update led mask
    if (led_direction == 0){
        led_mask <<= 1;
        if (led_mask == (0x01 << (PIO_LED_DATA_WIDTH-1)))
            led_direction = 1;
    }else{
        led_mask >>= 1;
        if (led_mask == 0x01){
            led_direction = 0;
            loop_count++;
        }
    }
}
} // while

```

Figure 7-8 Program for LED Shift Operation

■ Makefile and compile

Figure 7-9 shows the content of Makefile for this C project. The program includes the head files provided by SoC EDS. In the Makefile, ARM-linux cross-compile also be specified.

```
#
TARGET = HPS_FPGA_LED

#
ALT_DEVICE_FAMILY ?= soc_cv_av
SOCEDS_ROOT ?= $(SOCEDS_DEST_ROOT)
HWLIBS_ROOT = $(SOCEDS_ROOT)/ip/altera/hps/altera_hps/hwlib
CROSS_COMPILE = arm-linux-gnueabi-
CFLAGS = -g -Wall -D$(ALT_DEVICE_FAMILY) -I$(HWLIBS_ROOT)/include/$(ALT_DEVICE_FAMILY) -I$(HWLIBS_ROOT)/include/
LDFLAGS = -g -Wall
CC = $(CROSS_COMPILE)gcc
ARCH= arm

build: $(TARGET)
$(TARGET): main.o
$(CC) $(LDFLAGS) $^ -o $@
%.o : %.c
$(CC) $(CFLAGS) -c $< -o $@

.PHONY: clean
clean:
rm -f $(TARGET) *.a *.o *~
```

Figure 7-9 Makefile content

To compile the project, type “make” in the command shell as shown in **Figure 7-10**. Then, type “ls” to check the generated ARM execution file “HPS_FPGA_LED”.

```
matthew@matthew-PC /cygdrive/e/SVN/DE10_NANO_SOC/SoCFPGA/HPS_FPGA_LED
$ ls
hps_0.h main.c Makefile

matthew@matthew-PC /cygdrive/e/SVN/DE10_NANO_SOC/SoCFPGA/HPS_FPGA_LED
$ make
arm-linux-gnueabi-gcc -g -Wall -Dsoc_cv_av -ID:/altera/16.0/embedded/ip/altera/hps/altera_hps/hwlib/include/soc_cv_av -ID:/altera/16.0/embedded/ip/altera/hps/altera_hps/hwlib/include/ -c main.c -o main.o
arm-linux-gnueabi-gcc -g -Wall main.o -o HPS_FPGA_LED

matthew@matthew-PC /cygdrive/e/SVN/DE10_NANO_SOC/SoCFPGA/HPS_FPGA_LED
$ ls
hps_0.h HPS_FPGA_LED main.c main.o Makefile

matthew@matthew-PC /cygdrive/e/SVN/DE10_NANO_SOC/SoCFPGA/HPS_FPGA_LED
$
```

Figure 7-10 ARM C Project Compilation

■ Execute the Demo

To execute the demo, please boot the Linux from the SD-card in DE10-Nano. Copy the execution file “**HPS_FPGA_LED**” to the Linux directory, and type “**chmod +x HPS_FPGA_LED**” to add execution attribute to the execute file. Use Quartus Programmer to configure FPGA with the **DE10_NANO_SoC_GHRD.sof** generated in previous chapter. The LED0 will flash as the heat beat of the FPGA. Then, type “**./HPS_FPGA_LED**” to launch the ARM program. The LED[7..1] on DE10-Nano will be expected to perform 60 times of LED light shift operation, and then the program is terminated.

For details about booting the Linux from SD-card, please refer to the document:
Getting_Started_Guide.pdf

For details about copying files to Linux directory, please refer to the document:
My_First_HPS.pdf

Chapter 8

Programming the EPCS Device

This chapter describes how to program the serial configuration (EPCS) device with Serial Flash Loader (SFL) function via the JTAG interface. Users can program EPCS devices with a JTAG indirect configuration (.jic) file, which is converted from a user-specified SRAM object file (.sof) in Quartus. The .sof file is generated after the project compilation is successful. The steps of converting .sof to .jic in Quartus II are listed below.

8.1 Before Programming Begins

The FPGA should be set to AS x1 mode i.e. MSEL[4..0] = "10010" to use the Flash as a FPGA configuration device, as shown in Figure 8-1.

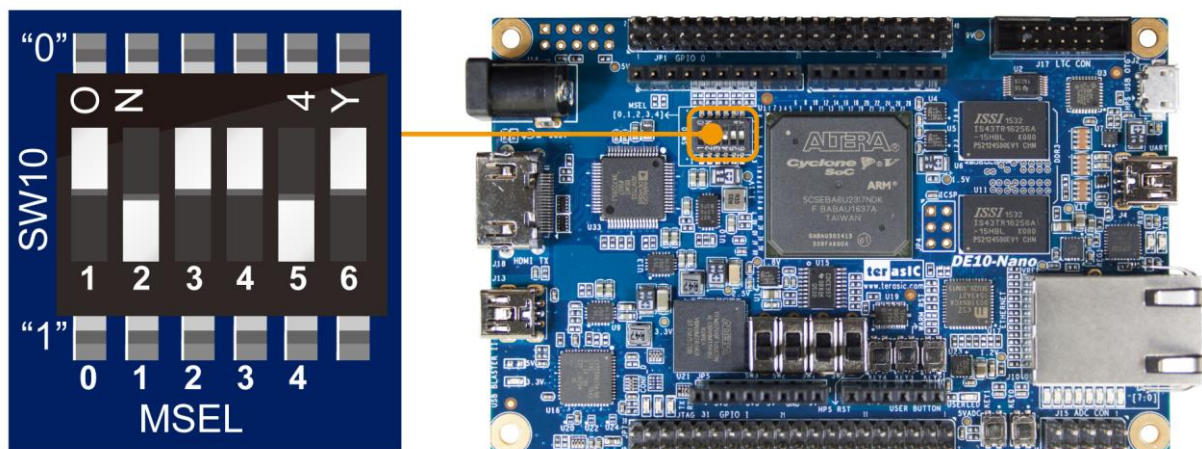

Figure 8-1 DIP switch (SW10) setting of Active Serial (AS) mode

8.2 Convert .SOF File to .JIC File

1. Choose **Convert Programming Files** from the File menu of Quartus II, as shown in **Figure 8-2**.

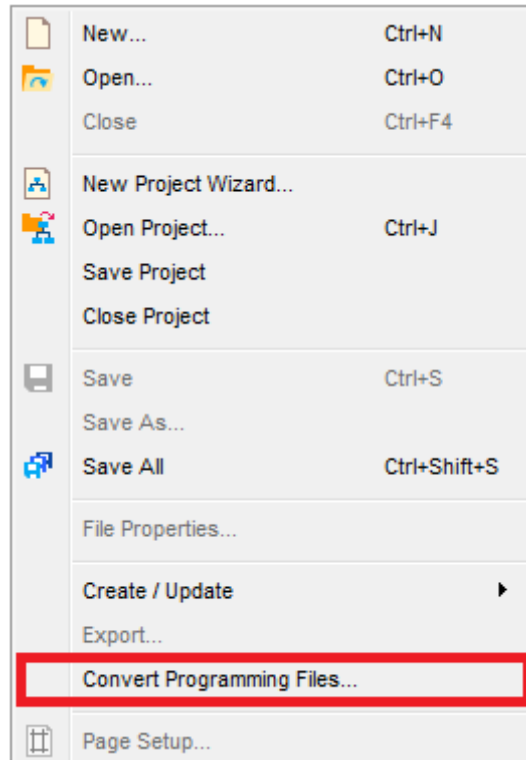

Figure 8-2 File menu of Quartus II

2. Select **JTAG Indirect Configuration File (.jic)** from the **Programming file type** field in the dialog of Convert Programming Files.
3. Choose EPCS128 from the Configuration device field.
4. Choose **Active Serial** from the **Mode** field.
5. Browse to the target directory from the **File name** field and specify the name of output file.
6. Click on the SOF data in the section of Input files to convert, as shown in **Figure 8-3**.

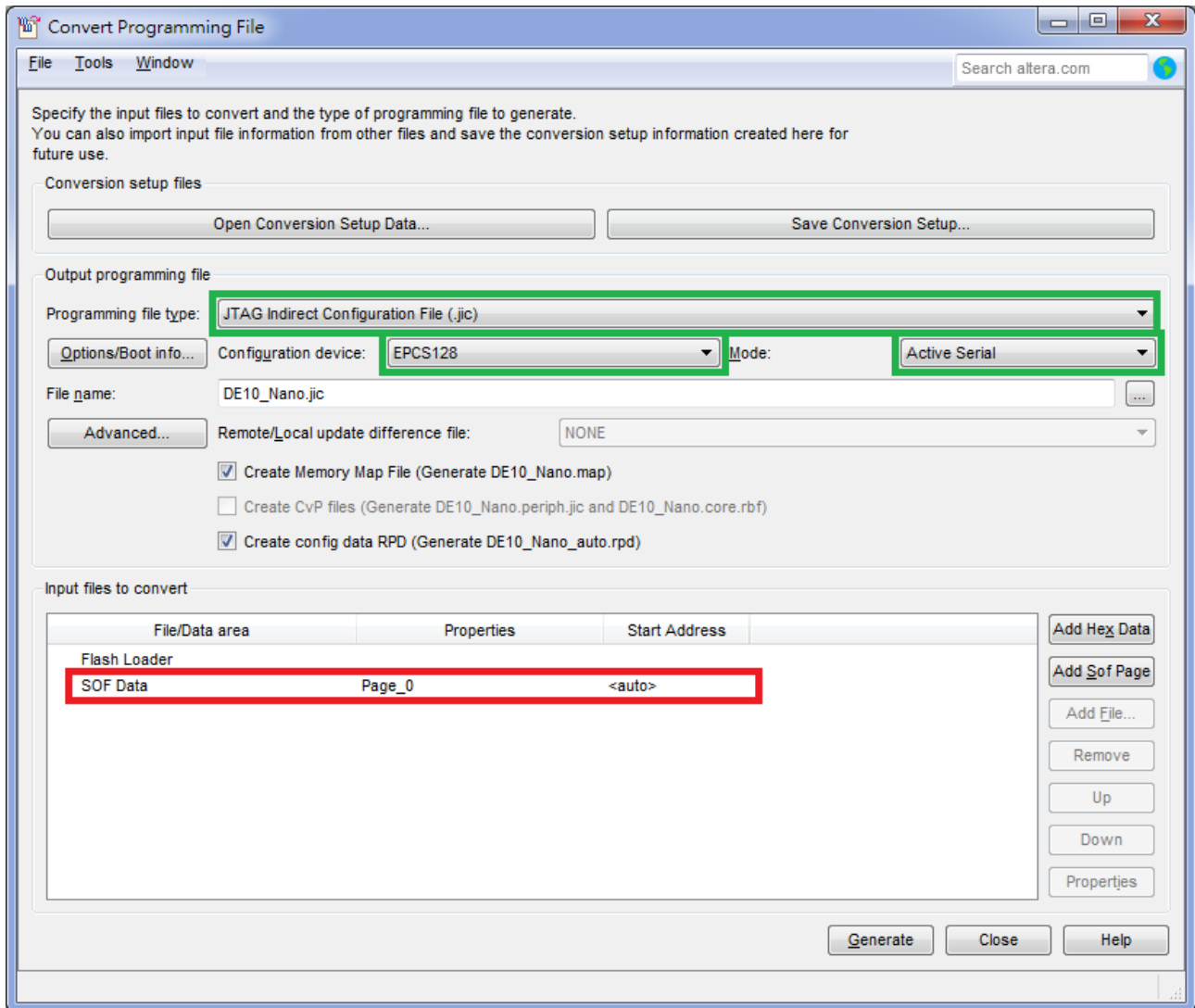

Figure 8-3 Dialog of “Convert Programming Files”

7. Click Add File.
8. Select the .sof to be converted to a .jic file from the Open File dialog.
9. Click **Open** and the **Convert Programming Files** page will appear.
10. Click on the Flash Loader and click Add Device, as shown in **Figure 8-4**.

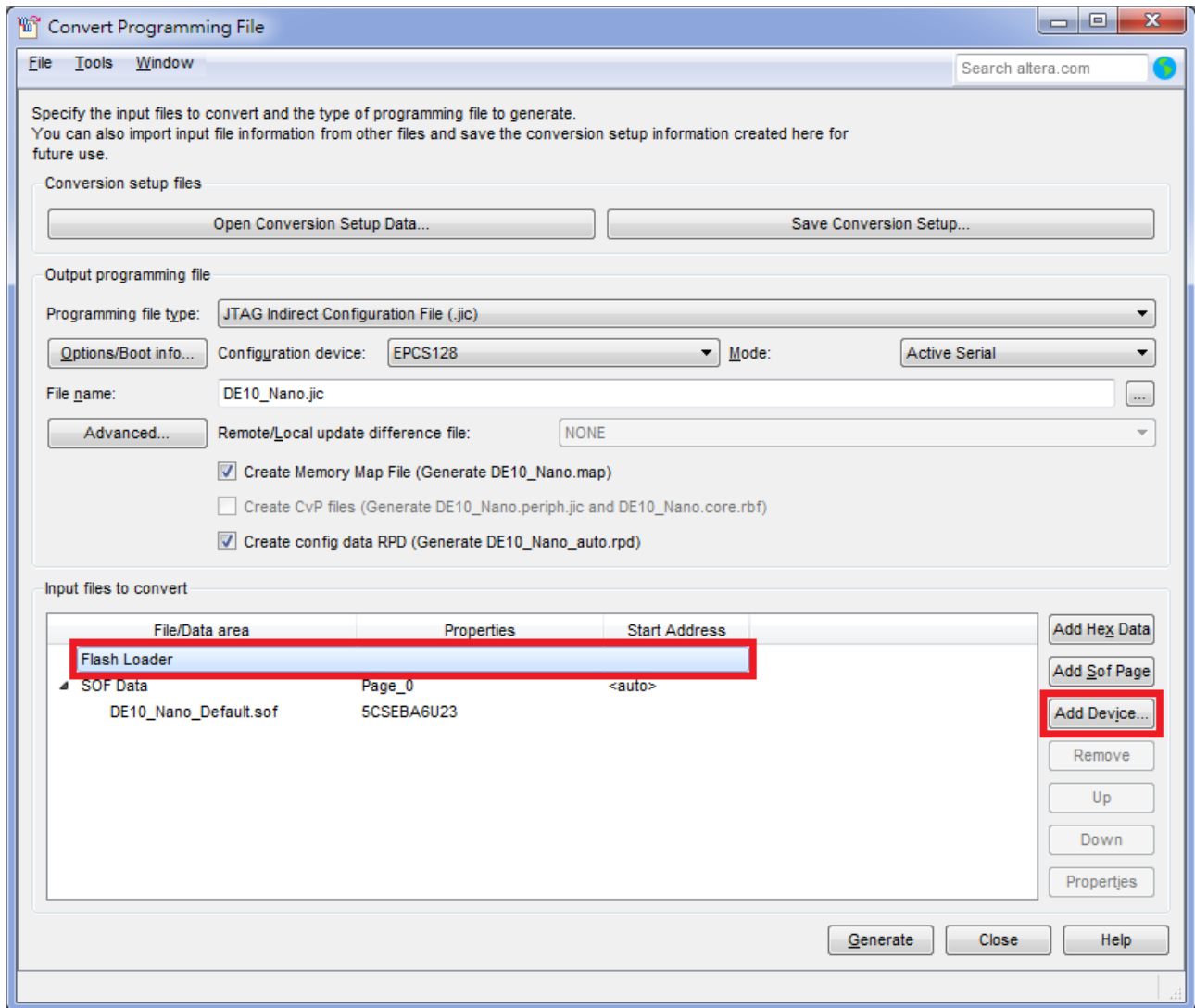

Figure 8-4 Click on the “Flash Loader”

11. The **Select Devices** page will appear, please select the targeted FPGA to be programmed into the EPCS, as shown in **Figure 8-5**.

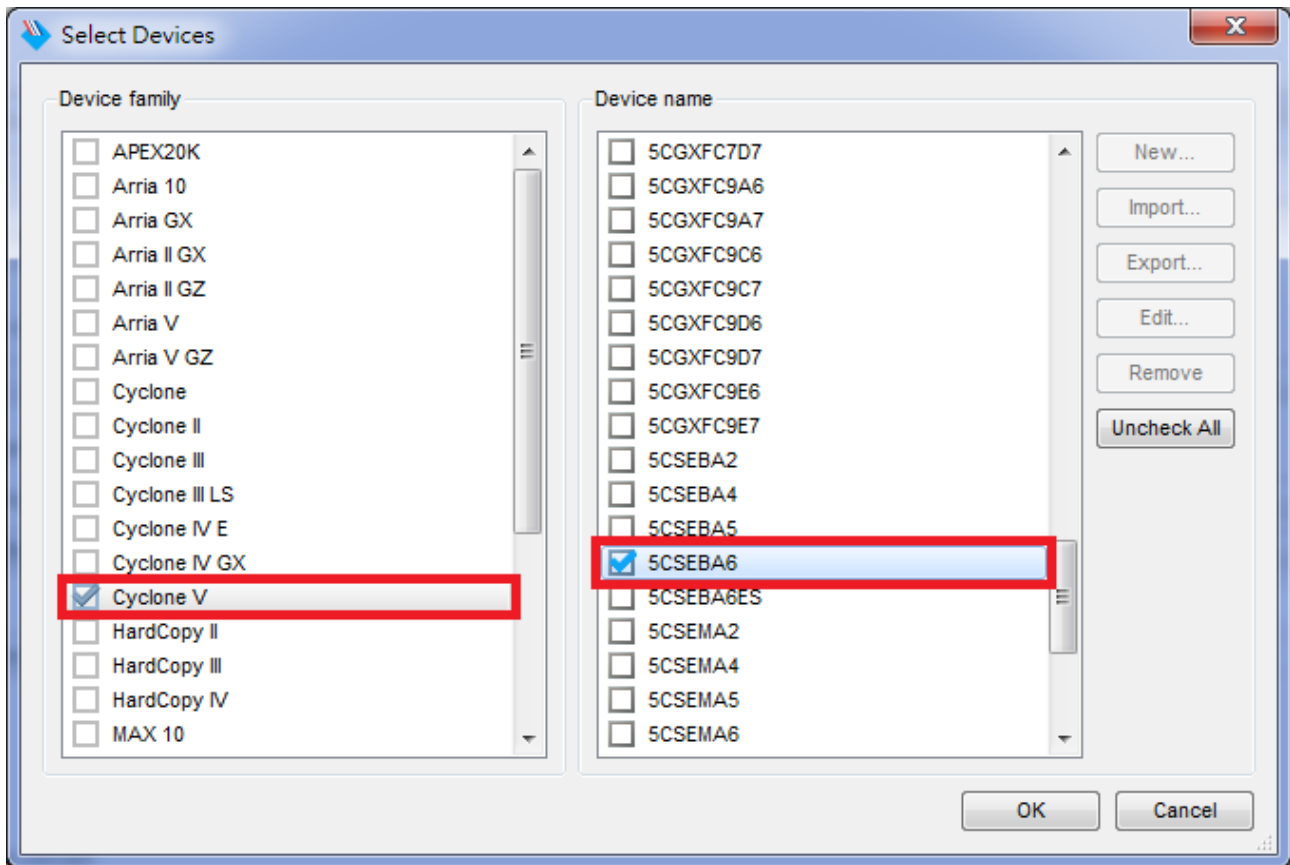

Figure 8-5 “Select Devices” page

12. Click OK and the Convert Programming Files page will appear, as shown in **Figure 8-6**.

13. Click Generate.

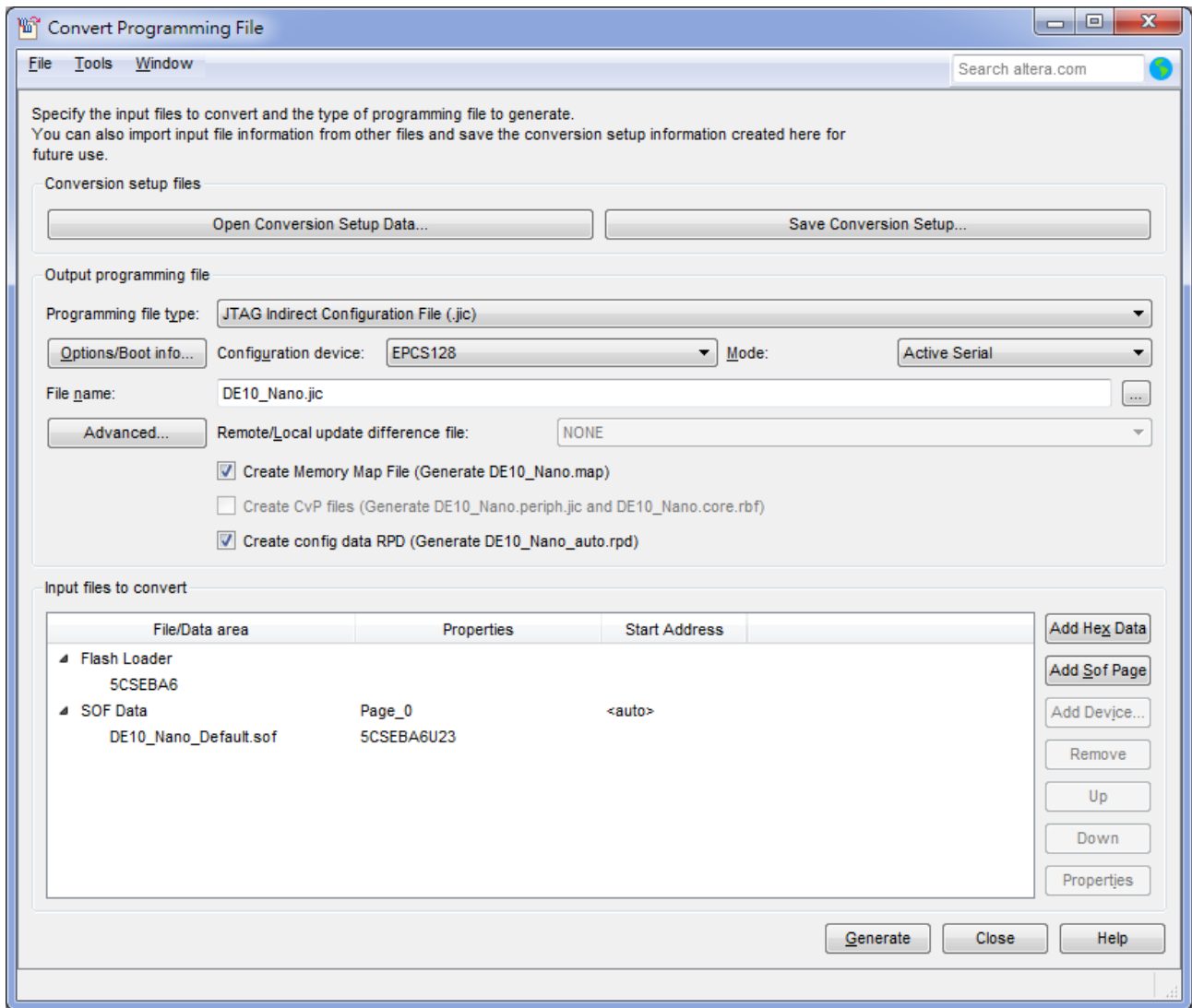

Figure 8-6 “Convert Programming Files” page after selecting the device

8.3 Write JIC File into the EPCS Device

When the conversion of SOF-to-JIC file is complete, please follow the steps below to program the EPCS device with the .jic file created in Quartus II Programmer.

1. Set MSEL[4..0] = "10010"
2. Choose **Programmer** from the Tools menu and the **Chain.cdf** window will appear.
3. Click **Auto Detect** and then select the correct device (5CSEBA6). Both FPGA device and HPS should be detected, as shown in **Figure 8-7**.
4. Double click the red rectangle region shown in **Figure 8-7** and the **Select New Programming File** page will appear. Select the .jic file to be programmed.
5. Program the EPCS device by clicking the corresponding **Program/Configure** box. A factory default SFL image will be loaded, as shown in **Figure 8-8**.
6. Click **Start** to program the EPCS device.

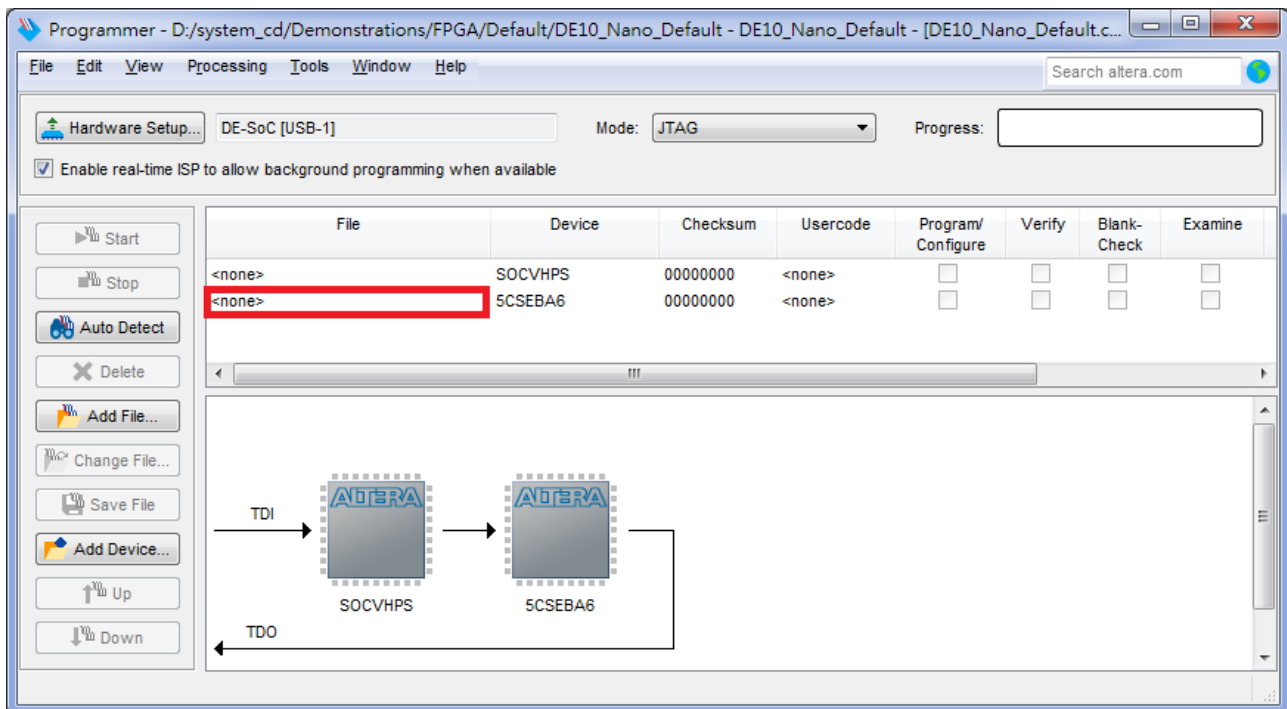

Figure 8-7 Two devices are detected in the Quartus II Programmer

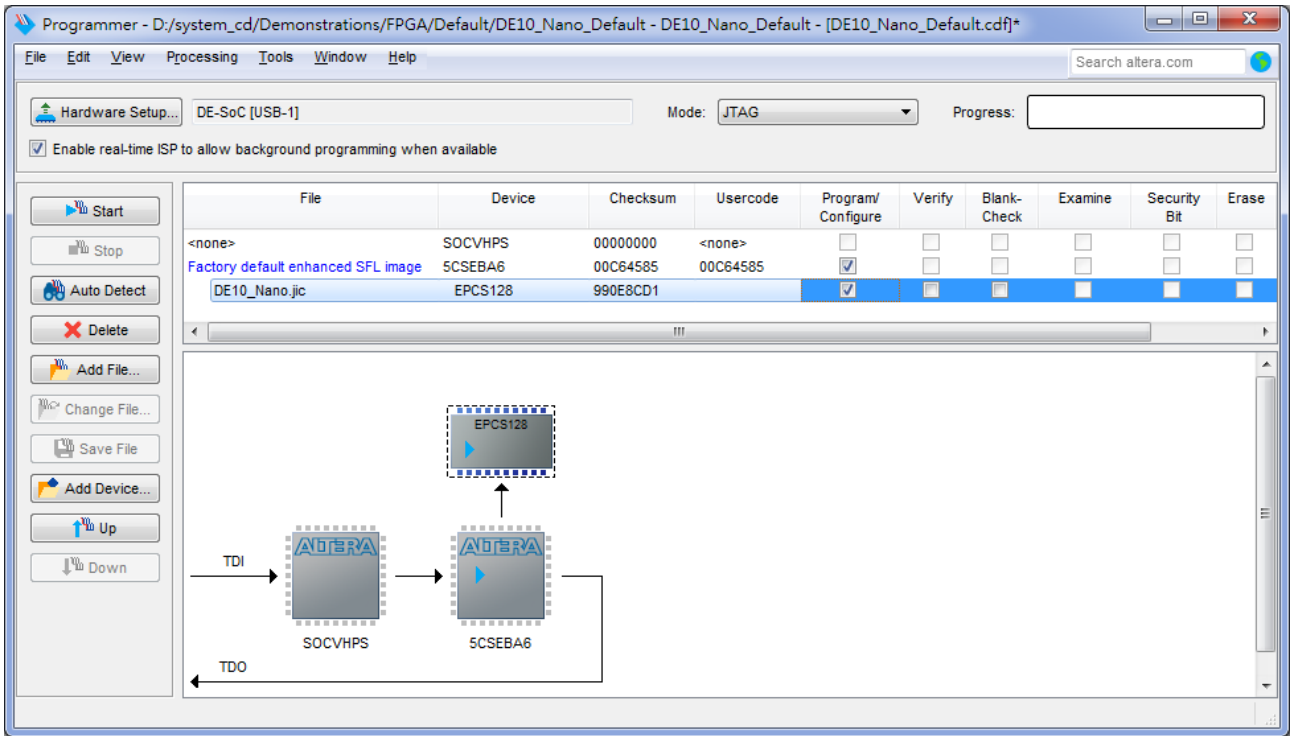

Figure 8-8 Quartus II programmer window with one .jic file

8.4 Erase the EPCS Device

The steps to erase the existing file in the EPCS device are:

1. Set MSEL[4..0] = "10010"
2. Choose **Programmer** from the **Tools** menu and the **Chain.cdf** window will appear.
3. Click **Auto Detect**, and then select correct device, both FPGA device and HPS will be detected. (See **Figure 8-7**)
4. Double click the red rectangle region shown in **Figure 8-7**, and the **Select New Programming File** page will appear. Select the correct .jic file.
5. Erase the EPCS device by clicking the corresponding **Erase** box. A factory default SFL image will be loaded, as shown in **Figure 8-9**.
6. Click **Start** to erase the EPCS device.

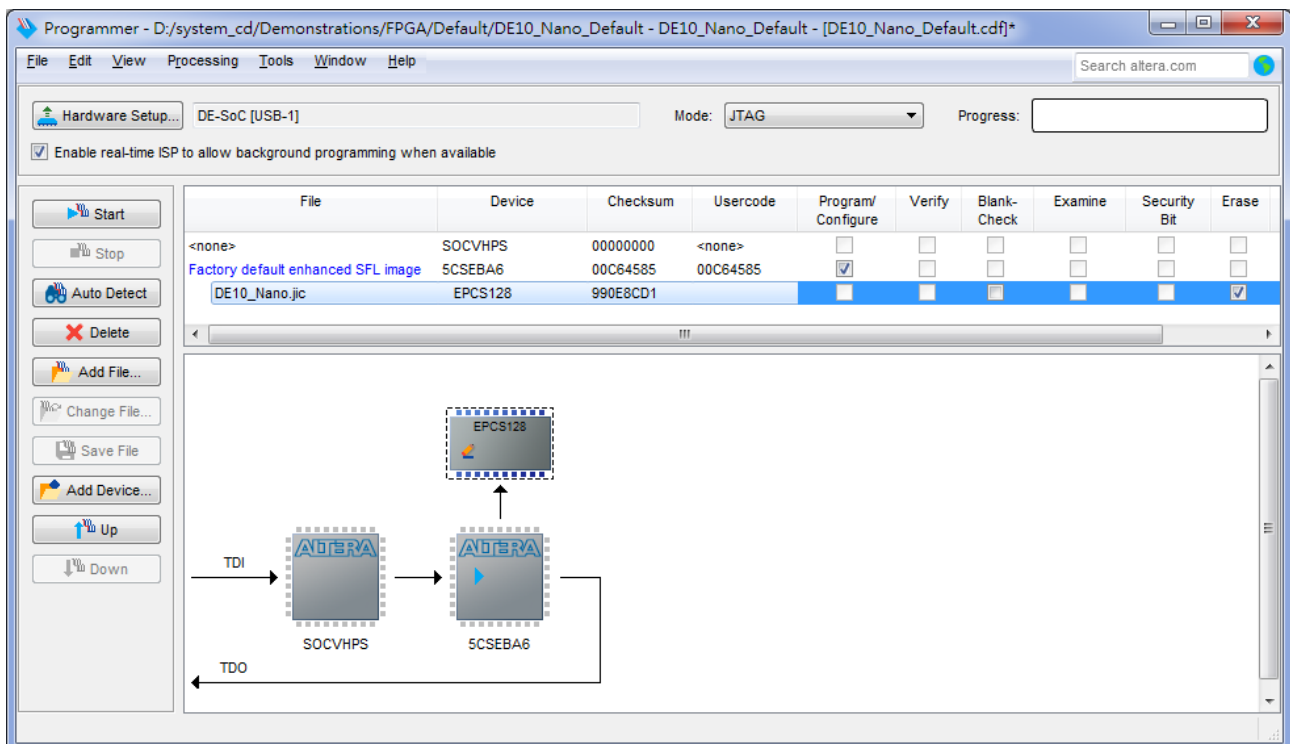

Figure 8-9 Erase the EPCS device in Quartus II Programmer

8.5 EPCS Programming via nios-2-flash-programmer

Before programming the EPCS via nios-2-flash-programmer, users must add an EPCS patch file nios-flash-override.txt into the Nios II EDS folder. The patch file is available in the folder Demonstation\EPCS_Patch of DE10-Nano System CD. Please copy this file to the folder [QuartusInstalledFolder]\nios2eds\bin (e.g. C:\altera\14.1\nios2eds\bin)

If the patch file is not included into the Nios II EDS folder, an error will occur as shown in **Figure 8-10**.

```
Using cable "USB-Blaster [USB-01]", device 1, instance 0x00  
Resetting and pausing target processor: OK  
No EPCS layout data - looking for section [EPCS-010216]  
Unable to use EPCS device  
Leaving target processor paused
```

Figure 8-10 Error Message “No EPCS Layout Data”.

Chapter 9

Appendix A

9.1 Revision History

Version	Change Log
V1.0	Initial Version (Preliminary)
V1.1	Add Section 5.5 and fixing typos.
V1.2	Fixing typos.
V1.3	Fixing typos.
V1.4	Fixing typos.
V1.5	Modify figure 3-2 for adding J8 description.
V1.6	Modify HPS_I2C1_SCLK pin assignment
V1.7	Fixing demonstration steps of Section 5.6
V1.8	Modify J8 description in Page 13

Copyright © 2017 Terasic Inc. All rights reserved.

Mouser Electronics

Authorized Distributor



Click to View Pricing, Inventory, Delivery & Lifecycle Information:

[Terasic:](#)





[P0496](#) [P0496-EDU](#)

Looking for pricing, stock, or lifecycle information?

Click below to explore more details on WIN SOURCE:

-  [View P0496 on WIN SOURCE](#)
-  [Terasic Inc. Information](#)

Optimize Your Supply Chain with WIN SOURCE Solutions

-  Global Sourcing Solution
-  Obsolete Management
-  Cost Control Management
-  Shortage Management
-  Alternative Solution
-  Excess Inventory Management