



**THE DATASHEET OF  
1EDF5673FXUMA1**



# GaN EiceDRIVER™ product family

Single-channel functional and reinforced isolated gate-drive ICs for high-voltage enhancement-mode GaN HEMTs

## Features

- Dedicated gate driver ICs for high-voltage GaN power switches (CoolGaN™, GIT technology based products)
  - low driving impedance (on-resistance 0.85 Ω source, 0.35 Ω sink)
  - resistor programmable gate current (typ. 10 mA) in steady “on” state
  - programmable negative gate voltage to completely avoid spurious turn-on
- Single output supply voltage (typ. 8 V, floating)
- Switching behavior independent of duty-cycle (2 "off" voltage levels)
- Differential concept to ensure negative gate drive voltage under any condition
- Fast input-to-output propagation (37 ns) with excellent stability (+7/-6 ns)
- Galvanic input-to-output isolation based on coreless transformer (CT) technology
- Common mode transient immunity (CMTI) > 200 V/ns
- 3 package versions
  - 1EDF5673K: 13-pin LGA (5 x 5 mm, PG-TFLGA-13-1) for functional isolation (1.5 kV)
  - 1EDF5673F: 16-pin P-DSO (150 mil, PG-DSO-16-11) for functional isolation (1.5 kV)
  - 1EDS5663H: 16-pin P-DSO (300 mil, PG-DSO-16-30) for reinforced isolation
- Fully qualified according to JEDEC for Industrial Applications

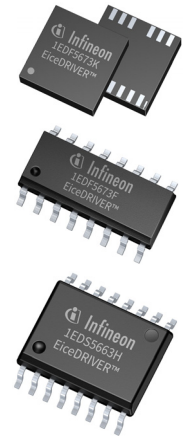

## Description

CoolGaN™ and similar GaN switches require a continuous gate current of a few mA in their "on" state. Besides, due to low threshold voltage and extremely fast switching transients, a negative "off" voltage level may be needed. The widely used RC-coupled gate driver fulfils these requirements, however it suffers from a duty-cycle dependence of switching dynamics and the lack of negative gate drive in specific situations.

Infineon's GaN EiceDRIVER™ solves these issues with very low effort. The two output stages shown below enable a zero “off” level to eliminate any duty-cycle dependence. In addition, the differential topology is able to provide negative gate drive without the need for a negative supply voltage. However, it requires a floating supply voltage not compatible with bootstrapping.

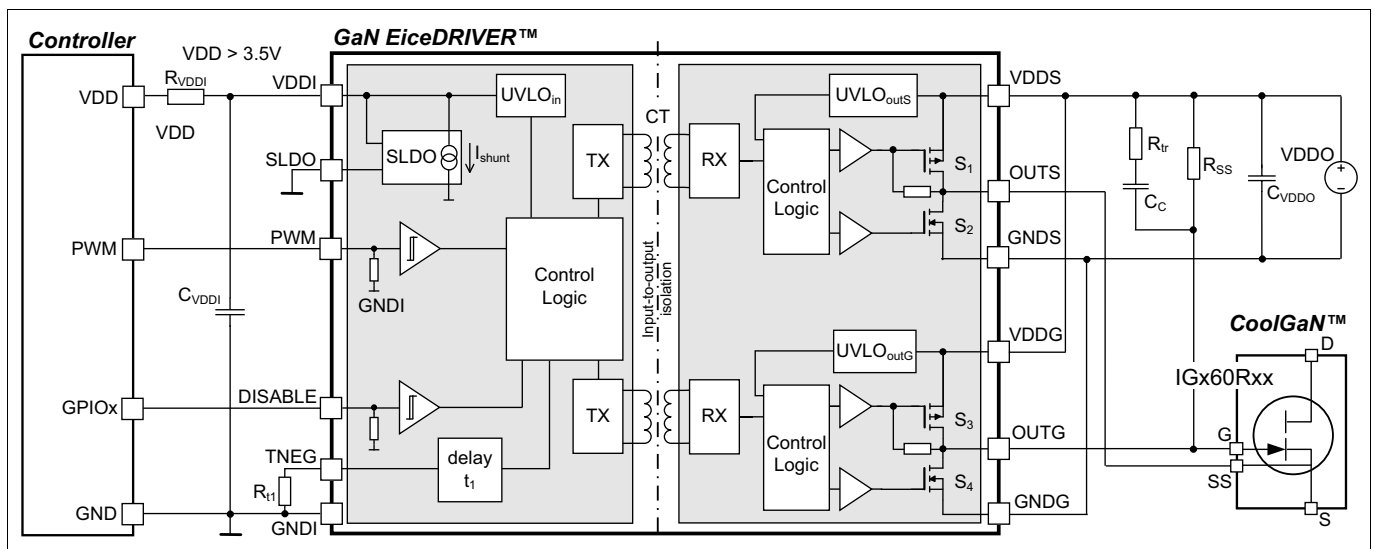

**Potential applications**

- Server, telecom and industrial SMPS
- Adapter and charger power supply

**Isolation and safety approval**

- 1EDS5663H with reinforced isolation: certification by VDE, UL according to
  - DIN V VDE V 0884-10 (2006-12) with  $V_{IOTM} = 8 \text{ kV}_{pk}$ ,  $V_{IOSM} = 6.25 \text{ kV}_{pk}$  (tested at  $10 \text{ kV}_{pk}$ )
  - UL 1577 (Ed. 5) with  $V_{ISO} = 5.7 \text{ kV}_{RMS}$
  - EN 62368-1
- 1EDF5673K and 1EDF5673F with functional isolation: production test with 1.5 kV for 10 ms

**Product versions**

In accordance with the isolation classification for primary and secondary side control, GaN EiceDRIVER™ is available in different package versions

**Table 1 GaN EiceDRIVER™ product family overview**

Part number	Package	Source/sink output resistance	Input-to-output isolation			
			Isolation class	Rating	Surge testing	Safety certification
1EDF5673K	LGA-13 5 x 5 mm	0.85 Ω / 0.35 Ω	functional	$V_{IO} = 1.5 \text{ kV}_{DC}$	n.a	n.a
1EDF5673F	DSO-16 150 mil	0.85 Ω / 0.35 Ω	functional	$V_{IO} = 1.5 \text{ kV}_{DC}$	n.a	n.a
1EDS5663H	DSO-16 300 mil	0.85 Ω / 0.35 Ω	reinforced (safe)	$V_{IOTM} = 8 \text{ kV}_{pk}$ (VDE0 884-10) $V_{ISO} = 5.7 \text{ kV}_{RMS}$ (UL 1577)	$V_{IOSM} > 10 \text{ kV}_{pk}$ (IEC60065)	VDE 0884-10 <sup>1)</sup> UL 1577 EN 62368-1

1) tested according to VDE0884-10 specifications with certification no longer available due to standard expiration

## Table of Contents

	<b>Features</b> .....	<b>1</b>
	<b>Table of Contents</b> .....	<b>3</b>
<b>1</b>	<b>Pin configuration and description</b> .....	<b>4</b>
<b>2</b>	<b>Background and system description</b> .....	<b>6</b>
<b>3</b>	<b>Functional description</b> .....	<b>9</b>
3.1	Block diagram .....	9
3.2	Isolation .....	9
3.3	Power supply .....	10
3.3.1	Input supply voltage .....	10
3.3.2	Output supply voltage .....	10
3.3.3	Power dissipation .....	10
3.4	Driver outputs .....	11
3.5	Undervoltage Lockout (UVLO) .....	11
3.6	CT communication and data transmission .....	11
3.7	Signal timing .....	11
<b>4</b>	<b>Electrical characteristics</b> .....	<b>13</b>
4.1	Absolute maximum ratings .....	13
4.2	Thermal characteristics .....	14
4.3	Operating range .....	15
4.4	Electrical characteristics .....	15
<b>5</b>	<b>Timing diagrams</b> .....	<b>18</b>
<b>6</b>	<b>Typical characteristics</b> .....	<b>19</b>
<b>7</b>	<b>Isolation specifications</b> .....	<b>23</b>
7.1	Functional isolation specifications .....	23
7.1.1	Functional isolation in PG-TFLGA-13-1 package (1EDF5673K) .....	23
7.1.2	Functional isolation in NB PG-DSO-16-11 package (1EDF5673F) .....	24
7.2	Reinforced isolation in WB PG-DSO-16-30 package (1EDS5663H) .....	25
7.3	Safety-limiting values .....	26
<b>8</b>	<b>Application circuit</b> .....	<b>27</b>
8.1	Dimensioning guidelines .....	28
<b>9</b>	<b>Layout guidelines</b> .....	<b>29</b>
<b>10</b>	<b>Package outline dimensions</b> .....	<b>31</b>
10.1	Package PG-TFLGA-13-1 .....	31
10.2	Package PG-DSO-16-11 .....	33
10.3	Package PG-DSO-16-30 .....	34
<b>11</b>	<b>Device numbers and markings</b> .....	<b>36</b>
<b>12</b>	<b>Revision History</b> .....	<b>37</b>

**Pin configuration and description**

**1 Pin configuration and description**

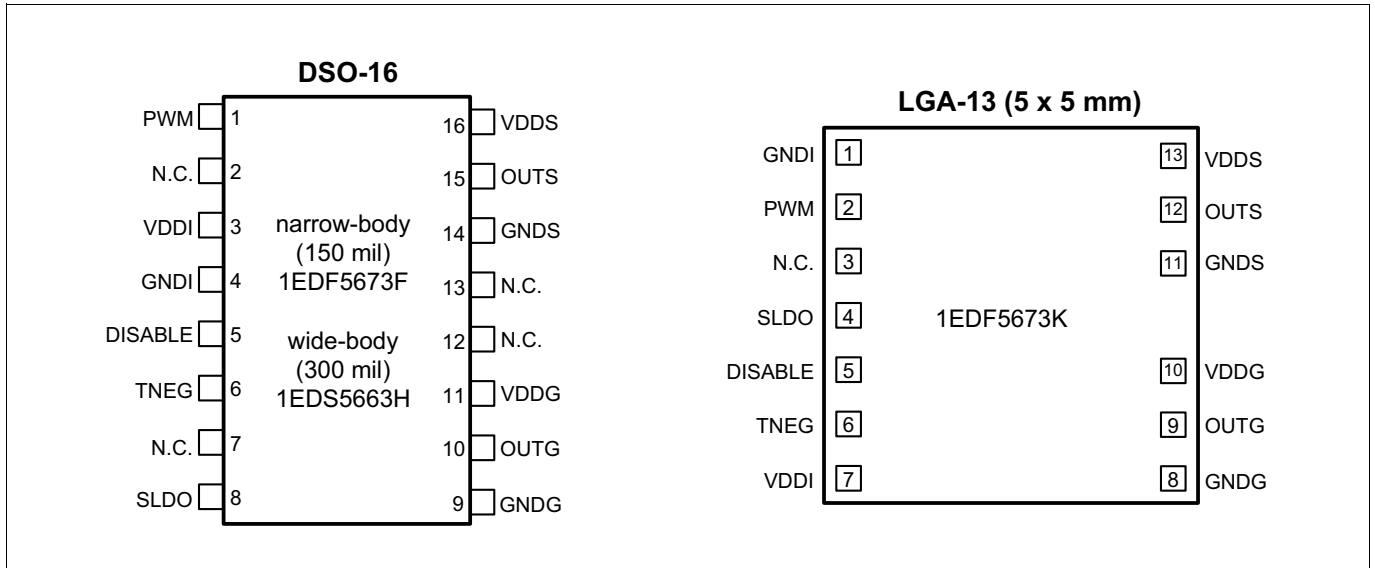

**Figure 1 Pin configuration for DSO-16 and LGA-13 packages, top view**

**Table 2 Pin description**

Pin DSO	Pin LGA	Symbol	Description
1	2	PWM	Input signal (default state Low) Controls switching sequence at OUTG and OUTS
2	3	N.C.	Do not connect
3	7	VDDI	Input supply voltage (+3.3 V)
4	1	GNDI	Input GND
5	5	DISABLE	Input signal (default state Low) Logic High is equivalent to a low state at PWM input
6	6	TNEG	Resistor programmable input to control the duration $t_1$ of negative "off" level ( <b>Figure 4</b> ); $t_1 = R_{t1} * 10.8 \text{ pF}$ with $R_{t1}$ ranges from 3 k $\Omega$ to 45 k $\Omega$ , typical value of $R_{t1}$ is 18 k $\Omega$
7	7	N.C.	Not connected
8	4	SLDO	N.C. or connected to VDDI: applied voltage (3.3 V) directly used as input supply voltage Connected to GNDI: Internal shunt regulator activated (VDD > 3.5 V)
9	8	GNDG	Ground for OUTG
10	9	OUTG	Output connectd to GaN gate
11	10	VDDG	Positive supply voltage for gate connected output stage
12	-	N.C.	Not connected
13	-	N.C.	Not connected
14	11	GNDS	Ground for OUTS (has to be connected with GNDG)

**Pin configuration and description**

**Table 2 Pin description**

<b>Pin DSO</b>	<b>Pin LGA</b>	<b>Symbol</b>	<b>Description</b>
15	12	OUTS	Output connected to GaN source
16	13	VDDS	Positive supply voltage for source connected output stage (has to be connected with VDDG)

Background and system description

## 2 Background and system description

Although gallium nitride high electron mobility transistors (GaN HEMTs) with ohmic pGaN gate like Infineon's 600 V CoolGaN™ power switches are robust enhancement-mode ("normally-on") devices, they differ significantly from MOSFETs. The gate module is not isolated from the channel, but behaves like a diode with a forward voltage  $V_F$  of 3 to 4 V. Equivalent circuit and typical gate input characteristic are given in **Figure 2**. In the steady "on" state a continuous gate current is required to achieve stable operating conditions. The switch is "normally-off", but the threshold voltage  $V_{th}$  is rather low ( $\sim +1$  V). This is why in certain applications a negative gate voltage  $-V_N$ , typically in the range of several volts, is required to safely keep the switch "off" (**Figure 2b**).

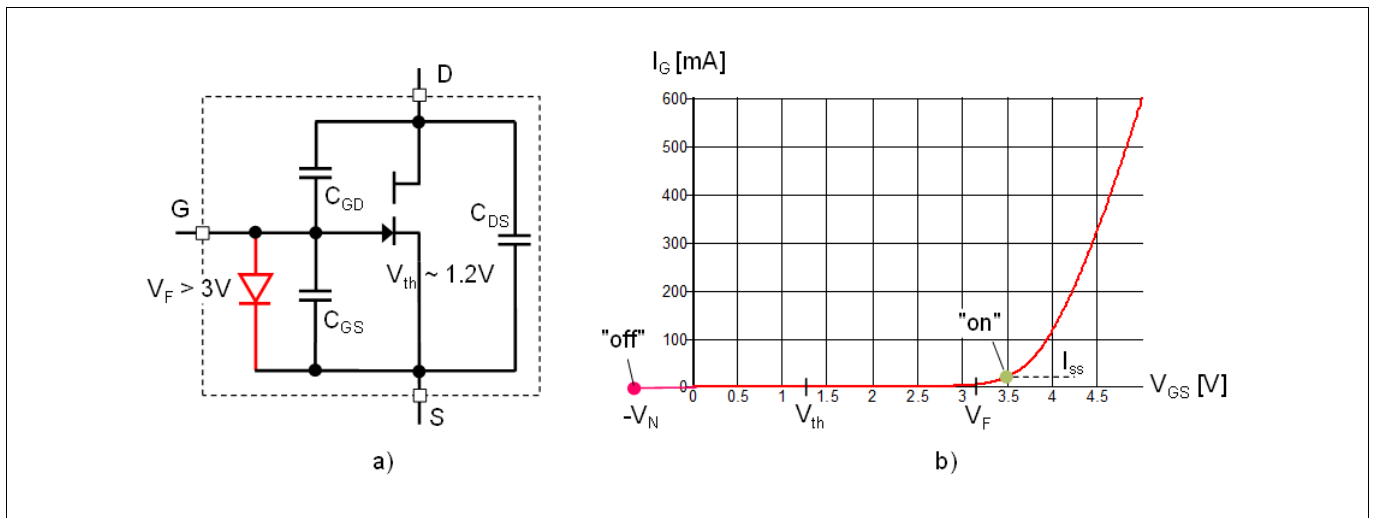

**Figure 2** Equivalent circuit (a) and gate input characteristics (b) of typical normally-off GaN HEMT

Obviously the transistor in **Figure 2** cannot be driven like a conventional MOSFET due to the need for a steady-state "on" current  $I_{ss}$  and a negative "off" voltage  $-V_N$ . While an  $I_{ss}$  of a few mA is sufficient, fast switching transients require gate charging currents  $I_{on}$  and  $I_{off}$  in the 1 A range. To avoid a dedicated driver with 2 separate "on" paths and bipolar supply voltage, the solution depicted in **Figure 3** is usually chosen, combining a standard gate driver with a passive RC circuit to achieve the intended behavior. The high-current paths containing the small gate resistors  $R_{on}$  and  $R_{off}$ , respectively, are connected to the gate via a coupling capacitance  $C_C$ .  $C_C$  is chosen to have no significant effect on the dynamic gate currents  $I_{on}$  and  $I_{off}$ . In parallel to the high-current charging path the much larger resistor  $R_{ss}$  forms a direct gate connection to continuously deliver the small steady-state gate current,  $I_{ss}$ . In addition,  $C_C$  can be used to generate a negative gate voltage. Obviously, in the "on"-state  $C_C$  is charged to the difference of driver supply  $V_{DD0}$  and diode voltage  $V_F$ . When switching to the "off" state, this charge is redistributed between  $C_C$  and  $C_{GS}$  and causes an initial negative  $V_{GS}$  of value

(2.1)

$$-V_N = -\frac{C_C \cdot (V_{DD0} - V_F) - Q_{Geq}}{C_C + C_{GS}}$$

with  $Q_{Geq}$  denoting an equivalent application-specific gate charge, i.e.  $Q_{Geq} \sim Q_{GS}$  for hard-switching and  $Q_{Geq} \sim Q_{GS} + Q_{GD}$  for soft-switching transitions.  $V_N$  can thus be controlled by proper choice of  $V_{DD0}$  and  $C_C$ . During the "off" state the negative  $V_{GS}$  decreases, as  $C_C$  is discharged via  $R_{ss}$ . The associated time constant cannot be chosen independently, but is related to the steady-state current and is typically in the 1  $\mu$ s range. The negative gate voltage at the end of the "off" phase ( $V_{Nf}$  in **Figure 3b**) thus depends on the "off" duration. It lowers the effective driver voltage for the following switching "on" event, resulting in a dependence of switching dynamics on frequency and duty cycle as one drawback of this approach.

Background and system description

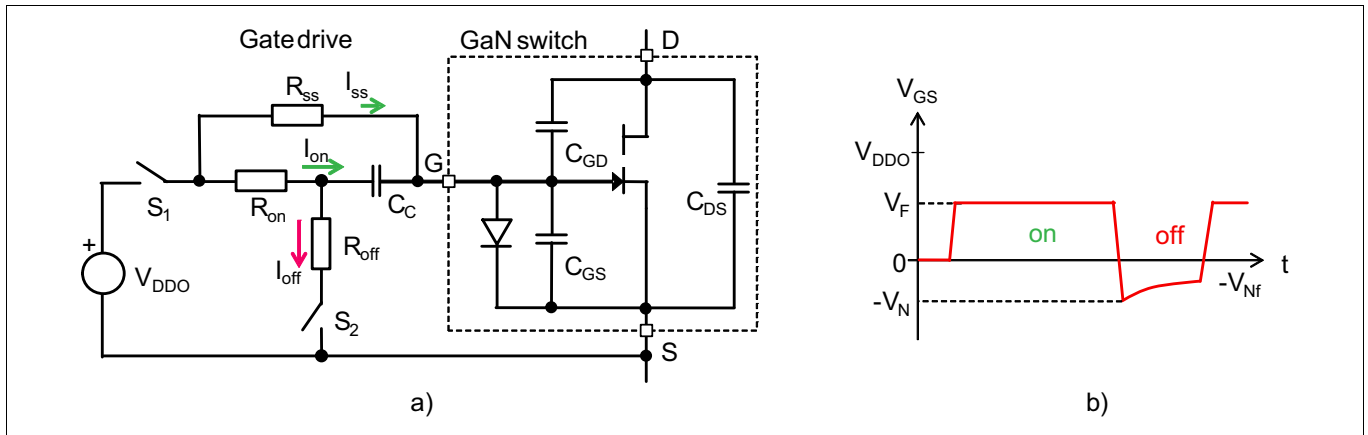

Figure 3 Equivalent circuit of GaN switch with RC gate drive (a) and gate-to-source voltage  $V_{GS}$  (b)

A second problem might happen if two switches are used alternately in a half-bridge configuration. In normal operation always one of the switches is "on", and before switching on the other one, it has to be switched off, thereby generating the negative gate voltage  $V_{Nf}$ . The usually short period with both switches "off" (dead time  $t_d$ ) does not cause a significant increase of  $V_{GS}$ . If, however, there is by any reason a longer period with both switches in "off" state (e.g. during system start-up, burst mode operation etc.), both coupling capacitors ( $C_C$ ) will be discharged. Thus, for the first switching pulse after such an extended non-switching period no negative voltage is available. This could lead to increased transistor stress or even instabilities due to spurious turn-on effects in half-bridge topologies.

To solve the problems described above, a shape of  $V_{GS}$  like the one in Figure 4b) would be required rather than the one in Figure 4a) which results from the simple RC circuit. As explained, a negative  $V_{GS}$  might be needed for safe "off" states during the switching transients, but it should be as low as possible. Due to the lack of a physical body diode any negative  $V_{GS}$  adds to the voltage drop of a GaN transistor in reverse polarity (diode operation) thereby increasing the conduction losses during dead time. Thus in the idealized waveform of Figure 4b)  $V_{GS}$  is switched to the minimum required  $V_N$  for a constant time  $t_1$  longer than the system dead time  $t_d$ . After that  $V_{GS}$  is switched back to zero to ensure identical conditions for the next switch "on" event and to minimize losses from diode operation. If, however, an "off" state lasts for a time  $t_2$  significantly longer than a normal switching period  $1/f_{sw}$  (e.g. several  $\mu s$ ),  $V_{GS}$  should be switched again to  $-V_{DDO}$  to avoid the described "first pulse" problem.

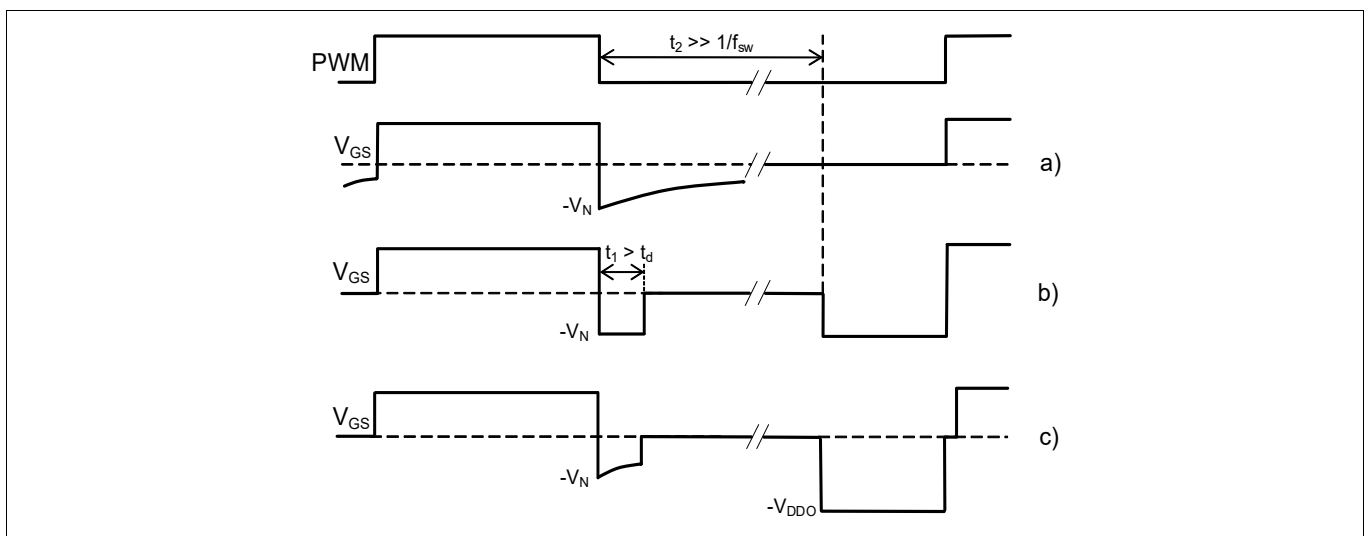

Figure 4  $V_{GS}$  voltage waveforms with RC circuit (a), improved (b) and proposed shape (c)

Background and system description

The conceptual goal of the GaN EiceDRIVER™ is to provide the gate voltage of **Figure 4b)** or a functional equivalent without significantly increasing driving complexity. This is achieved by slightly modifying the gate drive waveform as depicted in **Figure 4c)**. The "off" level after a long deadtime need not be the optimized negative voltage  $-V_N$ , it could also be the more negative level  $-V_{DDO}$ . As these "first pulse" situations happen very rarely compared with regular switching cycles, the resulting higher reverse voltage drop has negligible effect on switching losses.

Although going from the 3-level signal of **Figure 4b)** to the 4 levels of **Figure 4c)** seems to increase complexity at first sight, this is finally not true. Waveform c) can be realized in a very convenient way, if  $V_N$  is generated by the RC network as described above. Then the differential driver concept of **Figure 5a)** with switch control signals as given in **Figure 5b)** is able to fulfil all discussed requirements with lowest effort: a single supply voltage, 4 switches and 4 connection pins are sufficient.

As mentioned, utilizing  $-V_{DDO}$  instead of  $-V_N$  only during extended "off"-phases has no impact on switching losses. However, care has to be taken when switching on again, because  $C_C$  is fully charged to  $V_{DDO}$  in this "first pulse" situation and no current flow is possible via the capacitive path. With the standard switching-on scheme (open  $S_1$  / close  $S_2$ ) the transient current thus would be limited to the small steady-state current. To achieve a faster turn-on,  $C_{GS}$  will be discharged prior to the "on"-transient by switching on  $S_3$  for a short time  $t_3$  before initiating the actual "on"-transient via  $S_1$  and  $S_2$ . A  $t_3$ -duration of typically 20 ns is sufficient.

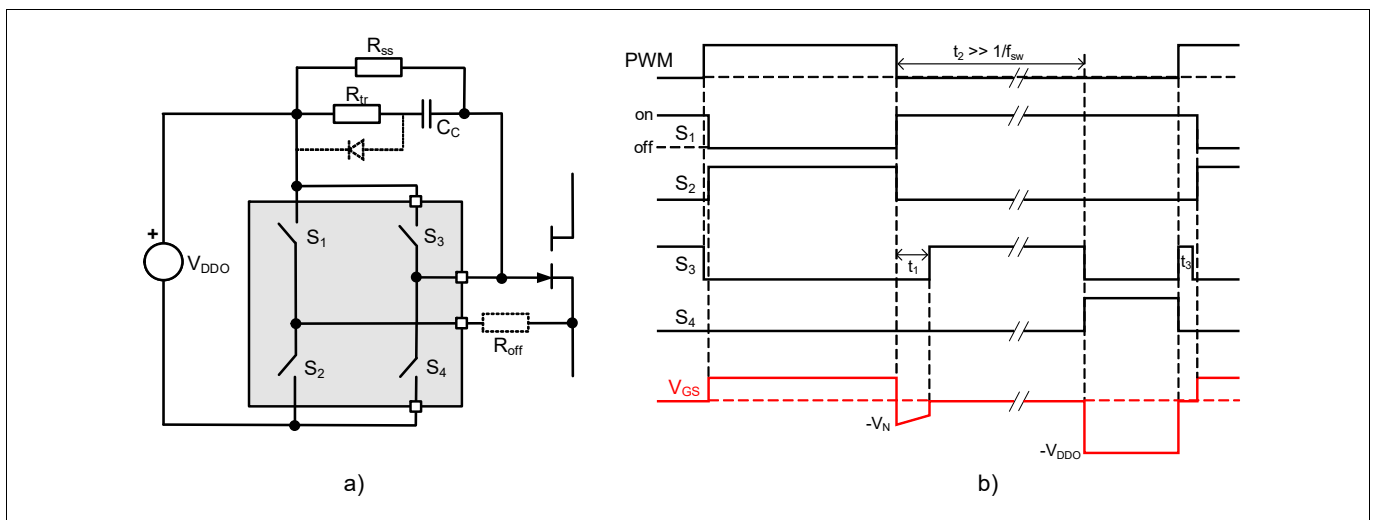

Figure 5 GaN EiceDRIVER™ concept (a) and switch control signals (b)

In the topology of **Figure 5a)** a single resistor  $R_{tr}$  is responsible for setting the maximum transient charging and discharging current. This is often acceptable. If it is not, an additional resistor  $R_{off}$  with series diode in parallel with  $R_{tr}$  can be used to realize different impedances for "on" and "off" transients, respectively. All relevant driving parameters are thus easily programmable by choosing  $V_{DDO}$ ,  $R_{ss}$ ,  $R_{tr}$ ,  $R_{off}$  and  $C_C$  according to **Equation (2.1)** and the relations

(2.2)

$$I_{ss} = \frac{V_{DDO} - V_F}{R_{ss}}, \quad I_{on,max} = \frac{V_{DDO}}{R_{tr} + R_{off}}, \quad I_{off,max} = \frac{V_{th} + V_N}{R_{off}}$$

## 3 Functional description

### 3.1 Block diagram

A simplified functional block diagram of the GaN EiceDRIVER™ is given in **Figure 6**. The 4 output transistors are placed on 2 separate dies. Isolation between input and outputs is achieved by means of two coreless transformer structures (CT) situated on the input die.

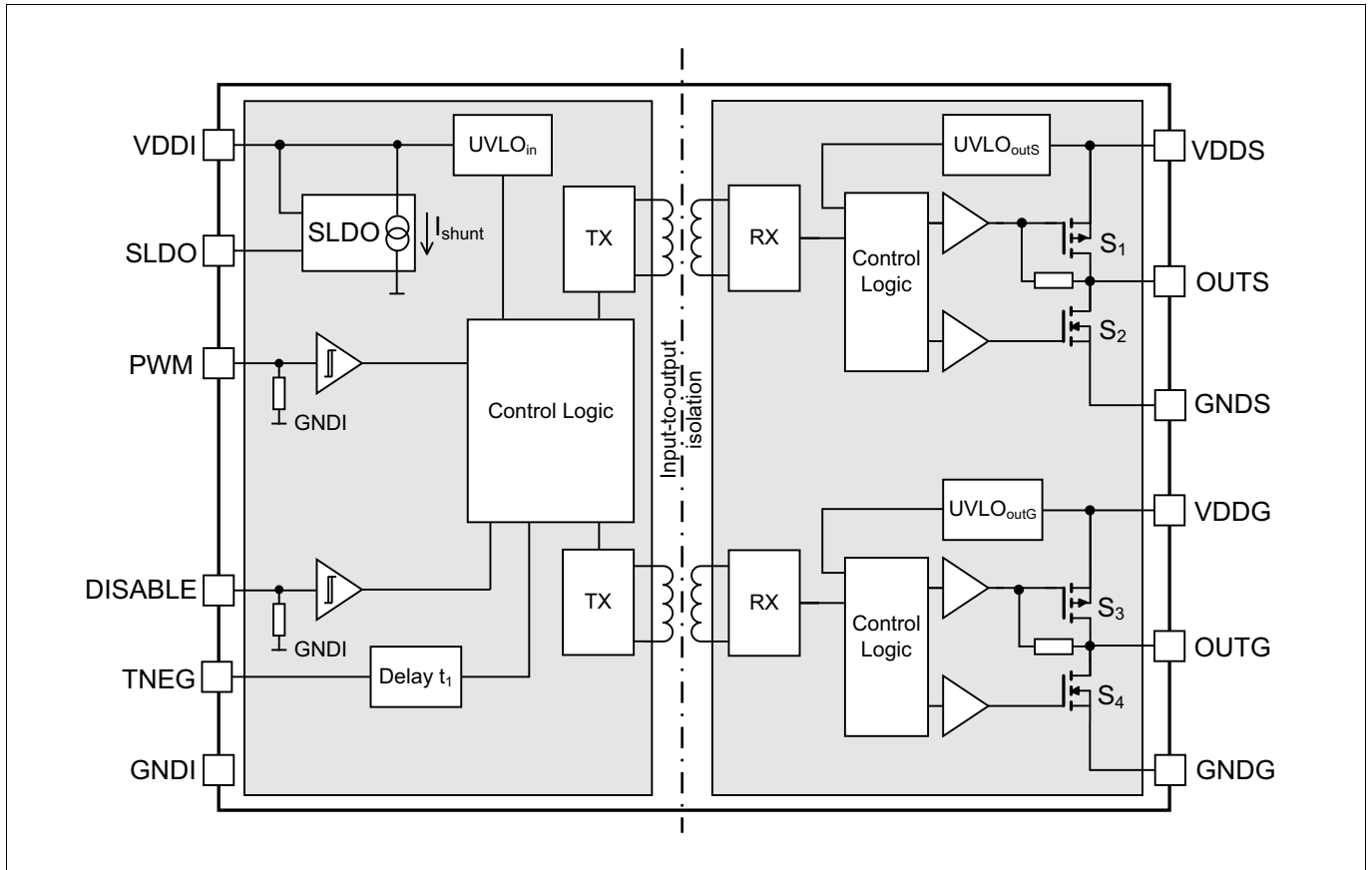

**Figure 6** Block diagram

### 3.2 Isolation

The GaN EiceDRIVER™ is available in three package versions in accordance with different classes of input-to-output isolation voltage requirements

- 1EDF5673K in LGA-13 5 x 5 mm package for functional isolation (1.5 kV)
- 1EDF5673F in DSO-16 narrow-body (150 mil) package for functional isolation (1.5 kV)
- 1EDS5663H in DSO-16 wide-body (300 mil) package for reinforced isolation

In SMPS functional isolation is typical for high-voltage systems that are controlled from their primary side, whereas high-voltage switches controlled from the secondary side require safe isolation.

The safe isolation version 1EDS5663H is tested according to VDE0884-10 standards as specified in **Table 15** to **Table 18**. As the CT forming this barrier is placed on the input die, a true "fail-safe" isolation is achieved, i.e. even in case of a destruction of the power switch the driver input remains safely isolated from the output.

# GaN EiceDRIVER™ product family

## GaN gate driver

### Functional description

### 3.3 Power supply

Due to the isolation between input and output side, two power domains with independent power management are required. Undervoltage Lockout (UVLO) functions for both input and output supplies ensure a defined start-up and robust functionality under all operating conditions.

#### 3.3.1 Input supply voltage

The input die is supplied via VDDI with a nominal voltage of 3.3 V. Power consumption to some extent depends on switching frequency, as the input signal is converted into a train of repetitive current pulses to drive the coreless transformer. Due to the chosen robust encoding scheme the average repetition rate of these pulses and thus the average supply current depends on the switching frequency  $f_{sw}$ . However, for  $f_{sw} < 500$  kHz this effect is very small.

The input side can also be operated with supply voltages higher than 3.3 V. Then a shunt LDO voltage regulator (SLDO) is enabled by connecting pin SLDO to GND. The SLDO regulates the current through an external resistor  $R_{VDDI}$  connected between the external supply voltage VDD and pin VDDI as depicted in the typical application circuit on [Page 1](#) to generate the required voltage drop. For proper operation it has to be ensured that the current through  $R_{VDDI}$  always exceeds the maximum supply current  $I_{VDDI,max}$  of the input chip.  $R_{VDDI}$  thus has to fulfil

(3.1)

$$R_{VDDI} < \frac{V_{DD} - 3.3V}{I_{VDDI,max}}$$

Then  $I_{shunt}$ , the excess current through  $R_{VDDI}$ , can be controlled by the SLDO to regulate  $V_{DDI}$  to a constant 3.3 V. A typical choice for  $V_{DD} = 5$  V could be  $R_{VDDI} = 470 \Omega$ , resulting in sufficient margin between resistor current and maximum average operating current. As usual, the dynamic peak current is provided by a blocking cap (10 to 22 nF) between  $V_{DDI}$  and GNDI.

#### 3.3.2 Output supply voltage

Both output dies and the respective output switches are supplied by a common voltage of typically 8 V between pins VDDS/G and GNDS/G. A ceramic bypass capacitance in the 20 to 100 nF range has to be placed close to the supply pins. The output supply must be floating with respect to the input supply system. This is not only required by the Kelvin source connection of the GaN switch (results in inductive voltage peaks between input and output ground during switching transient), but also by the differential driving concept as explained in [Chapter 2](#).

Again the minimum operating supply voltage is set by an undervoltage lockout function (UVLO<sub>out</sub>), operating independently of the input UVLO function.

#### 3.3.3 Power dissipation

The main power components associated with gate drive are the following: as usual, a first small part (< 20 mW) is due to the internal driver supply currents  $I_{VDDI}$  and  $I_{VDDO}$ ; they slightly depend on switching frequency via the CT encoding scheme (see [Typical characteristics](#) in [Chapter 6](#)). The second component results from charging the gate capacitance and is in the same range due to the low gate charge of GaN switches.

However, there are 2 more GaN-specific power components. The continuous gate current any CoolGaN™ switch requires in the steady on-state causes some tens of mW to be dissipated. And, as a consequence of the differential driving concept, additional power is dissipated during longer non-switching periods; this is associated with the application of  $V_{DDO}$  as negative gate-to-source voltage, because  $V_{DDO}$  is then loaded directly with  $R_{SS}$  (see [Figure 5](#)). In burst-mode operation the power depends on the burst/pause ratio and is typically also only a few tens of mW. During extended stand-by modes, however, powering down the  $V_{DDO}$  supply could save about

# GaN EiceDRIVER™ product family

## GaN gate driver

---

### Functional description

100 mW. It should also be pointed out that the internal gate/source clamp implemented in CoolGaN™ is connected in parallel with  $R_{SS}$  in this state. To avoid any significant additional current and power dissipation,  $V_{DDO}$  should be strictly limited to a maximum of 12 V.

As a summary, the total gate-drive power always stays in the 50 to 150 mW range and is thus sufficiently small to not cause any critical on-chip temperature increase.

### 3.4 Driver outputs

The rail-to-rail driver output stage realized with complementary MOS transistors is able to provide a typical 4 A sourcing and 8 A sinking current. Although these current levels are neither needed nor reached when driving GaN HEMTs (due to their low gate charge of only a few nC), the low on-resistance coming together with high driving current is nevertheless beneficial. With an  $R_{on}$  of 0.85  $\Omega$  for the sourcing pMOS and 0.35  $\Omega$  for the sinking nMOS transistor the driver can be considered as a nearly ideal switch. The gate drive parameters can thus be determined easily and accurately by the external components as described in [Chapter 2](#). The p-channel sourcing transistor enables real rail-to-rail behavior without suffering from the voltage drop unavoidably associated with nMOS source follower stages.

### 3.5 Undervoltage Lockout (UVLO)

The Undervoltage Lockout function ensures that the outputs can be switched only, if both input and output supply voltages exceed the corresponding UVLO threshold voltages. Thus it can be guaranteed, that the switch transistors are not operated, if the driving voltage is too low for complete and fast switching on, thereby avoiding excessive power dissipation.

The UVLO levels for the output supply are set to a typical "on" value of 4.5 and 5.5 V (with 0.3 V hysteresis) for OUTG and OUTS, respectively, whereas  $UVLO_{in}$  for  $V_{DDI}$  is set to 2.85 V with 0.15 V hysteresis. The different UVLO levels for OUTG and OUTS help to safely avoid any erroneous turn-on of the GaN switch despite the low GaN threshold voltage. Special attention has been paid to cover all possible operating conditions, like start-up or arbitrary supply voltage situations:

- if  $V_{DDI}$  drops below  $UVLO_{in}$ , a "switch-to-low" command is sent to output OUTG, whereas OUTS is switched to "high"; this corresponds to the final state in extended "off" periods with  $V_{GS} = -V_{DDO}$
- for  $V_{DD}$  lower than the output UVLO levels, an effective clamping concept has been realized by means of 100 k $\Omega$  resistors connecting the outputs OUTS and OUTG to the respective gates of the sourcing pMOS transistors in the output stage

As a result, safe operation of the GaN switch can be guaranteed under any circumstances.

### 3.6 CT communication and data transmission

A coreless transformer (CT) based communication module is used for PWM signal transfer between input and outputs. A proven high-resolution pulse repetition scheme in the transmitter combined with a watchdog time-out at the receiver side enables recovery from communication fails and ensures safe system shut-down in failure cases.

Besides, the repetition scheme is also used to signal a "first pulse" situation ([Figure 5](#)). If an "off"-state lasts longer than 32  $\mu$ s, the repetition rate of the CT pulses is reduced to a value that causes the watchdog on the output chip to wake up and initiate a change in the "off" state acc. to [Figure 5](#) (switch  $S_3$  to "off" and  $S_4$  to "on" state).

### 3.7 Signal timing

From the above, the extended "off"-phase  $t_2$  defining a "first pulse" situation, is fixed at a typical value of 32  $\mu$ s. The other important timing parameter  $t_1$ , i.e. the duration of the negative "off"-voltage, can be programmed by

# GaN EiceDRIVER™ product family

## GaN gate driver

---

### Functional description

a resistor  $R_{t1}$  connected from TNEG to GNDI according to  $t_1 = R_{t1} * 10.8 \text{ pF}$ . As the main idea is to keep the switch in a safe "off" state during the switching transient,  $t_1$  must be longer than the system dead time  $t_d$ , i.e. the maximum time both switches in a half-bridge are in "off" state. The upper limit for  $t_1$  obviously is the minimum "off"-period; within these limits ( $t_d < t_1 < t_{\text{off,min}}$ ), the actual  $t_1$  value is completely uncritical without any effect on switching dynamics.

The above condition refers to systems with a fixed dead-time (complementary high-side and low-side control signals). In topologies with non-complementary signals (TCM PFC, active clamp flyback converter, burst mode operation) it cannot always be fulfilled. Then a limited number of "first pulse" situations may occur. However, as this typically happens in resonant topologies at low current values, the safe operating area of the switch is usually not exceeded.

**Electrical characteristics**

**4 Electrical characteristics**

**4.1 Absolute maximum ratings**

The absolute maximum ratings are listed in **Table 3**. Stresses beyond these values may cause permanent damage to the device. Exposure to absolute maximum rating conditions for extended periods may affect device reliability.

**Table 3 Absolute maximum ratings**

Parameter	Symbol	Values			Unit	Note or Test Condition
		Min.	Typ.	Max.		
Voltage at pin VDDI	$V_{DDI}$	-0.3	–	4.0	V	1)
Output supply voltage	$V_{DDO}$	-0.3	–	22	V	–
Voltage at pins PWM and DISABLE	$V_{IN}$	-0.3	–	17	V	–
		-5	–	–	V	< 50 ns for transient <sup>2)</sup>
Voltage at pins TNEG and SLDO	$V_{TNEG}$	-0.3	–	$V_{DDI} + 0.3$	V	–
	$V_{SLDO}$					
Voltage at pins OUTS, OUTG	$V_{OUTS/G}$	-0.3	–	$V_{DDO} + 0.3$	V	–
		-2	–	$V_{DDO} + 1.5$	V	< 200 ns <sup>2)</sup>
Reverse current peak at pins OUTS, OUTG	$I_{SRC\_rev}$	-5	–	–	$A_{pk}$	< 500 ns <sup>2)</sup>
	$I_{SNK\_rev}$	–	–	5	$A_{pk}$	
Non-destructive Common Mode Transient Immunity	CMTI	400	–	–	V/ns	outputs with respect to input
Junction temperature	$T_J$	-40	–	150	°C	–
Storage temperature	$T_{STG}$	-65	–	150	°C	–
Soldering temperature	$T_{SOL}$	–	–	260	°C	reflow/wave soldering <sup>3)</sup>
ESD capability	$V_{ESD\_CDM}$	–	–	0.5	kV	Charged Device Model (CDM) <sup>4)</sup>
ESD capability	$V_{ESD\_HBM}$	–	–	2	kV	Human Body Model (HBM) <sup>5)</sup>

- 1) if the SLDO is activated (SLDO pin connected to GNDI), the input-side supply voltage does not correspond to  $V_{DDI}$  and can be higher
- 2) parameter verified by design, not tested in production
- 3) according to JESD22A111
- 4) according to ANSI/ESDA/JEDEC JS-002
- 5) according to ANSI/ESDA/JEDEC JS-001

**Electrical characteristics**

**4.2 Thermal characteristics**

**Table 4 Thermal characteristics at  $T_A = 25^\circ\text{C}$**

Parameter	Symbol	Values			Unit	Note or Test Condition
		Min.	Typ.	Max.		
<b>PG-TFLGA-13-1 package</b>						
Thermal resistance junction-ambient <sup>1)</sup>	$R_{thJA25}$	–	112	–	K/W	–
Thermal resistance junction-case (top) <sup>2)</sup>	$R_{thJC25}$	–	44	–	K/W	–
Thermal resistance junction-board <sup>3)</sup>	$R_{thJB25}$	–	66	–	K/W	–
Characterization parameter junction-top <sup>4)</sup>	$\Psi_{thJT25}$	–	7.7	–	K/W	–
Characterization parameter junction-board <sup>4)</sup>	$\Psi_{thJB25}$	–	5.6	–	K/W	–
<b>PG-DSO-16-30 package</b>						
Thermal resistance junction-ambient <sup>1)</sup>	$R_{thJA25}$	–	59	–	K/W	–
Thermal resistance junction-case (top) <sup>2)</sup>	$R_{thJC25}$	–	32	–	K/W	–
Thermal resistance junction-board <sup>3)</sup>	$R_{thJB25}$	–	33	–	K/W	–
Characterization parameter junction-top <sup>4)</sup>	$\Psi_{thJT25}$	–	8.9	–	K/W	–
Characterization parameter junction-board <sup>4)</sup>	$\Psi_{thJB25}$	–	7.7	–	K/W	–
<b>PG-DSO-16-11 package</b>						
Thermal resistance junction-ambient <sup>1)</sup>	$R_{thJA25}$	–	51	–	K/W	–
Thermal resistance junction-case (top) <sup>2)</sup>	$R_{thJC25}$	–	25	–	K/W	–
Thermal resistance junction-board <sup>3)</sup>	$R_{thJB25}$	–	36	–	K/W	–
Characterization parameter junction-top <sup>4)</sup>	$\Psi_{thJT25}$	–	4.4	–	K/W	–
Characterization parameter junction-board <sup>4)</sup>	$\Psi_{thJB25}$	–	5.4	–	K/W	–

- 1) obtained by simulating a JEDEC-standard, high-K board, as specified in JESD51-7, in an environment described in JESD51-2a.
- 2) obtained by simulating a cold plate test on the package top. No specific JEDEC standard test exists, but a close description can be found in the ANSI SEMI standard G30-88.
- 3) obtained by simulating an environment with a ring cold plate fixture to control the PCB temperature, as described in JESD51-8.
- 4) estimates the junction temperature of a device in a real system and is extracted from the simulation data for obtaining  $R_{th}$ , using a procedure described in JESD51-2a (sections 6 and 7).

**Electrical characteristics**

**4.3 Operating range**

**Table 5 Operating range**

Parameter	Symbol	Values			Unit	Note or Test Condition
		Min.	Typ.	Max.		
Voltage at pin VDDI	$V_{DDI}$	3	–	3.5	V	1)
Output supply voltage	$V_{DDO}$	6.5	8	20 <sup>2)</sup>	V	Min. defined by UVLO
VDDI blocking capacitance	$C_{VDDI}$	–	–	22	nF	SLDO active (connected to GNDI)
Resistor defining $t_1$	$R_{t1}$	3	18	45	k $\Omega$	–
Logic input voltage at pins PWM and DISABLE	$V_{IN}$	0	–	6.5	V	–
Voltage at pins SLDO	$V_{SLDO}$	0	–	3.5	V	–
Junction temperature	$T_J$	-40	–	150 <sup>3)</sup>	$^{\circ}\text{C}$	
Ambient temperature	$T_A$	-40	–	125	$^{\circ}\text{C}$	–

- 1) if the SLDO is activated (SLDO pin connected to GNDI), the input-side supply voltage does not correspond to  $V_{DDI}$  and can be higher
- 2) for CoolGaN™ HEMTs  $V_{DDO} < 12\text{ V}$  is recommended
- 3) continuous operation above 125 $^{\circ}\text{C}$  may reduce lifetime

**4.4 Electrical characteristics**

Unless otherwise noted, min./max. values of characteristics are the lower and upper limits, respectively. They are valid within the full operating range. Typical values are given at  $T_J = 25^{\circ}\text{C}$  with  $V_{DDI} = 3.3\text{ V}$  and  $V_{DDO} = 8\text{ V}$

**Table 6 Power supply**

Parameter	Symbol	Values			Unit	Note or Test Condition
		Min.	Typ.	Max.		
VDDI quiescent current	$I_{VDDIqu}$	–	1.5	–	mA	no switching
VDDO quiescent current	$I_{VDDOqu}$	–	1.3	–	mA	no switching

**Table 7 Static output characteristics**

Parameter	Symbol	Values			Unit	Note or Test Condition
		Min.	Typ.	Max.		
High level (sourcing) output resistance	$R_{on\_SRC}$	0.42	0.85	1.6	$\Omega$	$I_{SRC} = 50\text{ mA}$
Peak sourcing output current	$I_{SRC\_pk}$	–	4	1)	A	–
Low level (sinking) output resistance	$R_{on\_SNK}$	0.18	0.35	0.75	$\Omega$	$I_{SNK} = 50\text{ mA}$
Peak sinking output current	$I_{SNK\_pk}$	2)	-8	–	A	–

- 1) actively limited to approx. 5.2  $A_{pk}$ , not subject to production test - verified by design / characterization
- 2) actively limited to approx. -10.2  $A_{pk}$ , not subject to production test - verified by design / characterization

**Electrical characteristics**

**Table 8 Dynamic characteristics,  $T_{J,max} = 125^{\circ}\text{C}$  (see Figure 7 and Figure 8)**

Parameter	Symbol	Values			Unit	Note or Test Condition
		Min.	Typ.	Max.		
PWM to OUTS propagation delay	$t_{PDOnS}$	31	37	44	ns	load between OUTS and GNDs $C_{LS} = 1.8 \text{ nF}$
	$t_{PDOffS}$	–	41	–		
PWM to OUTG propagation delay	$t_{PDOnG}$	–	$t_{PDOffS} + t_1$	–	ns	load between OUTG and GNDG $Z_{LG} = 1.8 \text{ nF} // 20 \Omega$
	$t_{PDOffG}$	31	37	44		
DISABLE to OUTS propagation delay	$t_{PD\_DISon}$ $t_{PD\_DISoff}$	–	–	100	ns	$C_{LS} = 1.8 \text{ nF}$
Rise time OUTS / OUTG	$t_{rise}$	–	6.5	12 <sup>1)</sup>	ns	$C_{LS} = C_{LG} = 1.8 \text{ nF}$ , 10% to 90%
Fall time OUTS	$t_{fall}$	–	4.5	8 <sup>1)</sup>	ns	$C_{LS} = 1.8 \text{ nF}$ , 90% to 10%
Minimum input pulse width that changes output state	$t_{PW}$	–	18	–	ns	–
Duration of negative gate “off” voltage	$t_1$	–	194	–	ns	$R_{t1} = 18 \text{ k}\Omega$
Minimum “off” time before entering “first pulse” mode	$t_2$	–	32 <sup>1)</sup>	–	$\mu\text{s}$	–
Discharging time in “first pulse” mode	$t_3$	–	20 <sup>1)</sup>	–	ns	–

1) verified by design, not tested in production

**Table 9 Undervoltage Lockout**

Parameter	Symbol	Values			Unit	Note or Test Condition
		Min.	Typ.	Max.		
Undervoltage Lockout input (UVLO <sub>in</sub> ) turn on threshold	UVLO <sub>in</sub>	2.75	2.85	2.95	V	–
Undervoltage Lockout (UVLO <sub>in</sub> ) turn off threshold	UVLO <sub>in-</sub>	–	2.7	–	V	–
UVLO <sub>in</sub> threshold hysteresis	$\Delta\text{UVLO}_{in}$	0.1	0.15	0.2	V	–
Undervoltage Lockout outputs (UVLO <sub>outG/S</sub> ) turn on threshold	UVLO <sub>outG</sub>	4.7	5.0	5.3	V	–
	UVLO <sub>outS</sub>	5.4	5.8	6.2		
UVLO <sub>out</sub> turn off thresholds	UVLO <sub>outG-</sub>	–	4.5	–	V	–
	UVLO <sub>outS-</sub>	–	5.2	–	V	–
UVLO <sub>out</sub> threshold hysteresis	$\Delta\text{UVLO}_{outG}$	0.3	0.45	0.6	V	–
	$\Delta\text{UVLO}_{outS}$	0.4	0.6	0.8		

Electrical characteristics

Table 10 Logic inputs PWM and DISABLE

Parameter	Symbol	Values			Unit	Note or Test Condition
		Min.	Typ.	Max.		
Input voltage threshold for transition LH	$V_{INL}$	1.7	2.0	2.3	V	independent of $V_{DDI}$
Input voltage threshold for transition HL	$V_{INH}$	–	1.2	–	V	independent of $V_{DDI}$
Input voltage hysteresis	$\Delta V_{IN}$	0.4	0.8	1.2	V	–
Input pull down resistor	$R_{IN}$	–	150	–	k $\Omega$	–

Timing diagrams

## 5 Timing diagrams

**Figure 7** depicts rise, fall and delay times as observed at the capacitively loaded outputs OUTS and OUTG, resp. As OUTG is not actively switched to low, a resistor in parallel with the load capacitance has to be used for testing. In addition to the signal propagation delay  $t_{PDon}$ , the rising edge of OUTG is delayed by a time  $t_1$  defining the duration of negative  $V_{GS}$ .

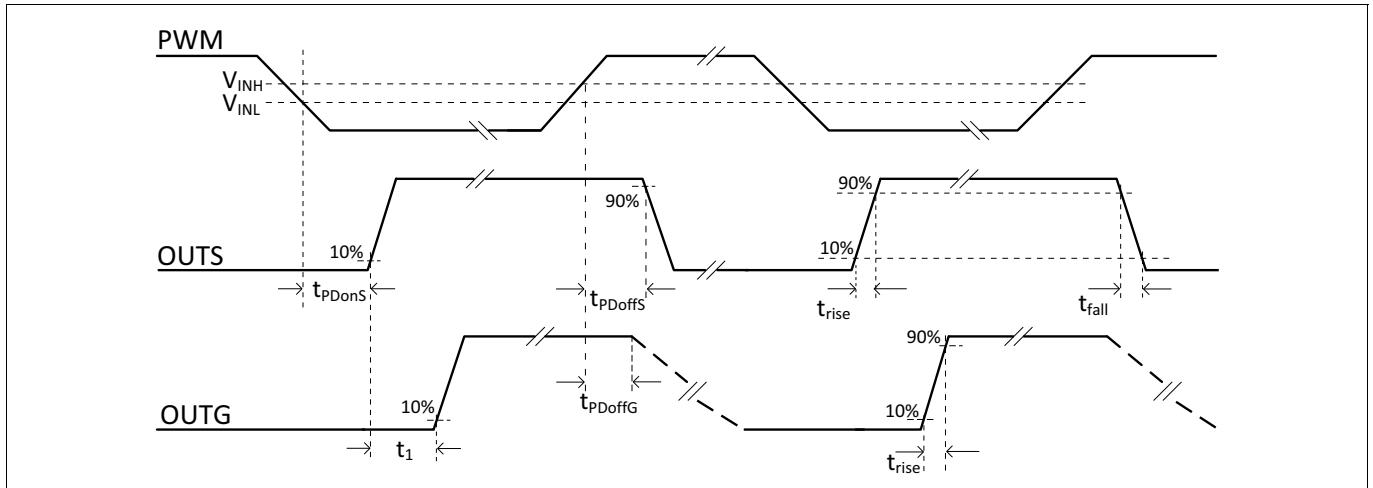

**Figure 7 Propagation delay, rise and fall time**

**Figure 8** illustrates a complete switching sequence of the four switches forming the two output stages of GaN EiceDRIVER™ (delay, rise and fall times not shown). The sequence in the left part of **Figure 8** corresponds to the normal switching operation, whereas in the right part the "first pulse" situation is depicted. This situation is assumed to happen whenever there is no switching action for an extended period  $t_2$ . Clearly  $t_2$  must be significantly longer than a regular switching period. A typical duration of 32  $\mu$ s has been chosen, as GaN switches usually operate at switching frequencies significantly above 50 kHz (switching period below 20  $\mu$ s).

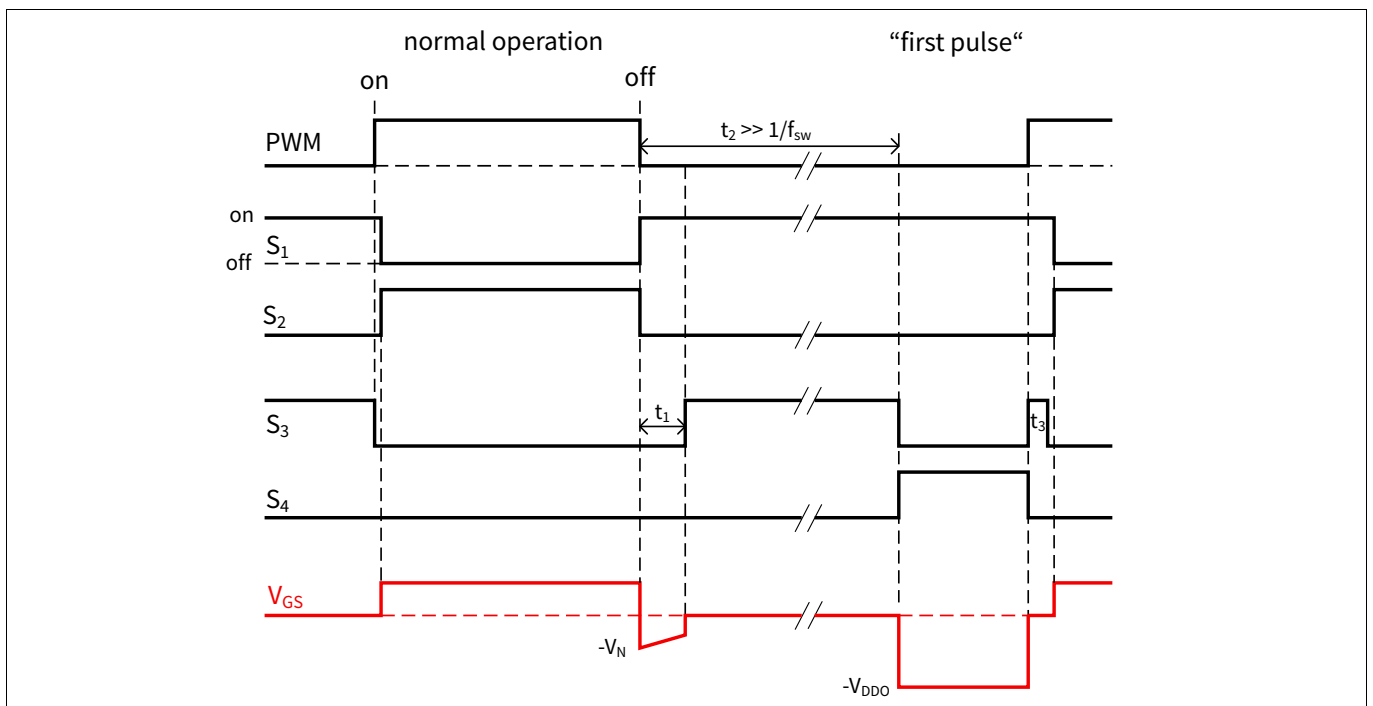

**Figure 8 Input signal, output switch sequence and resulting  $V_{GS}$  for normal operation and "first pulse" situation**

Typical characteristics

### 6 Typical characteristics

$V_{DD} = 8\text{ V}$ ,  $V_{DDI} = 3.3\text{ V}$ ,  $T_A = 25^\circ\text{C}$ , no load (unless otherwise noted)

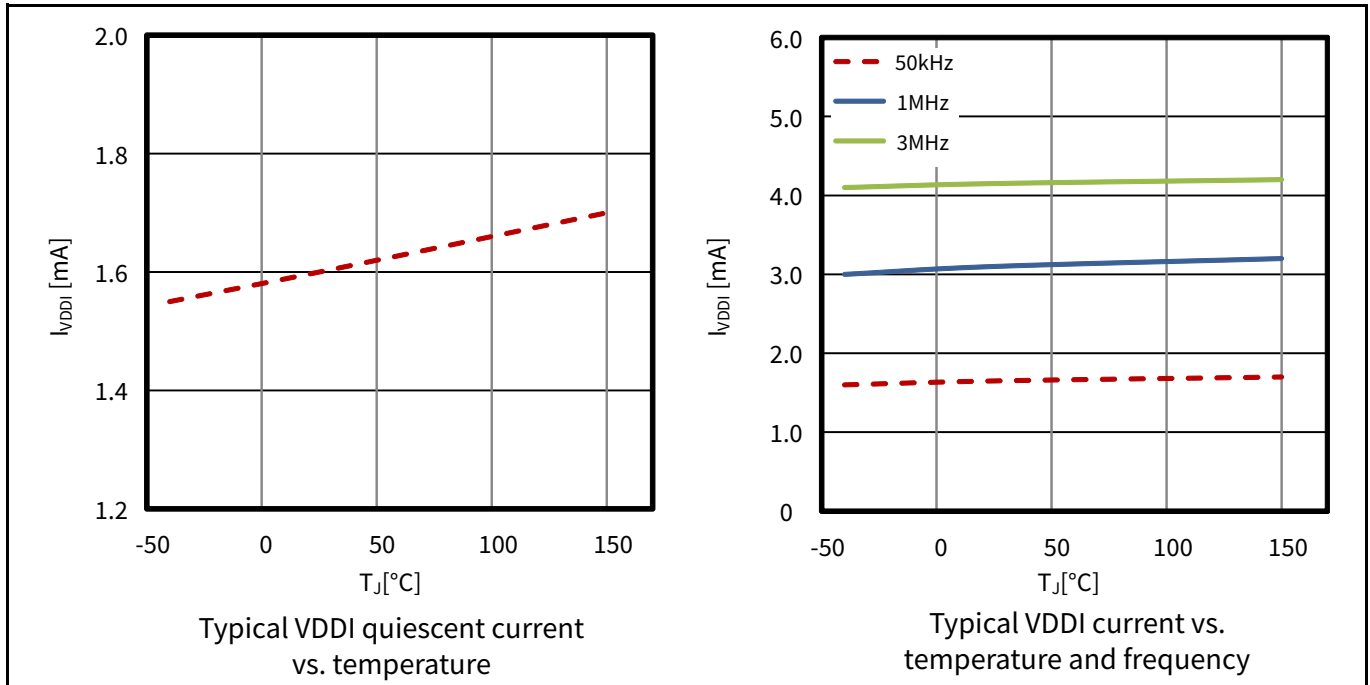

Figure 9 Supply current VDDI

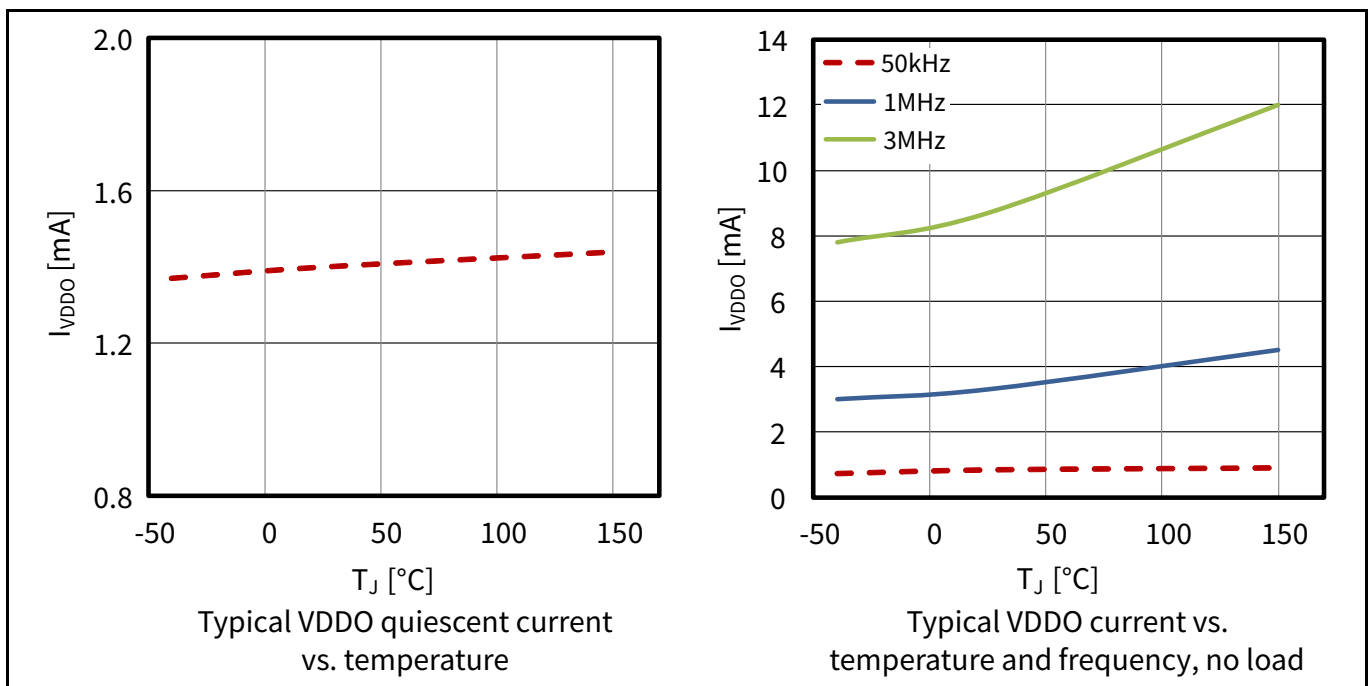

Figure 10 Supply current VDDO

Typical characteristics

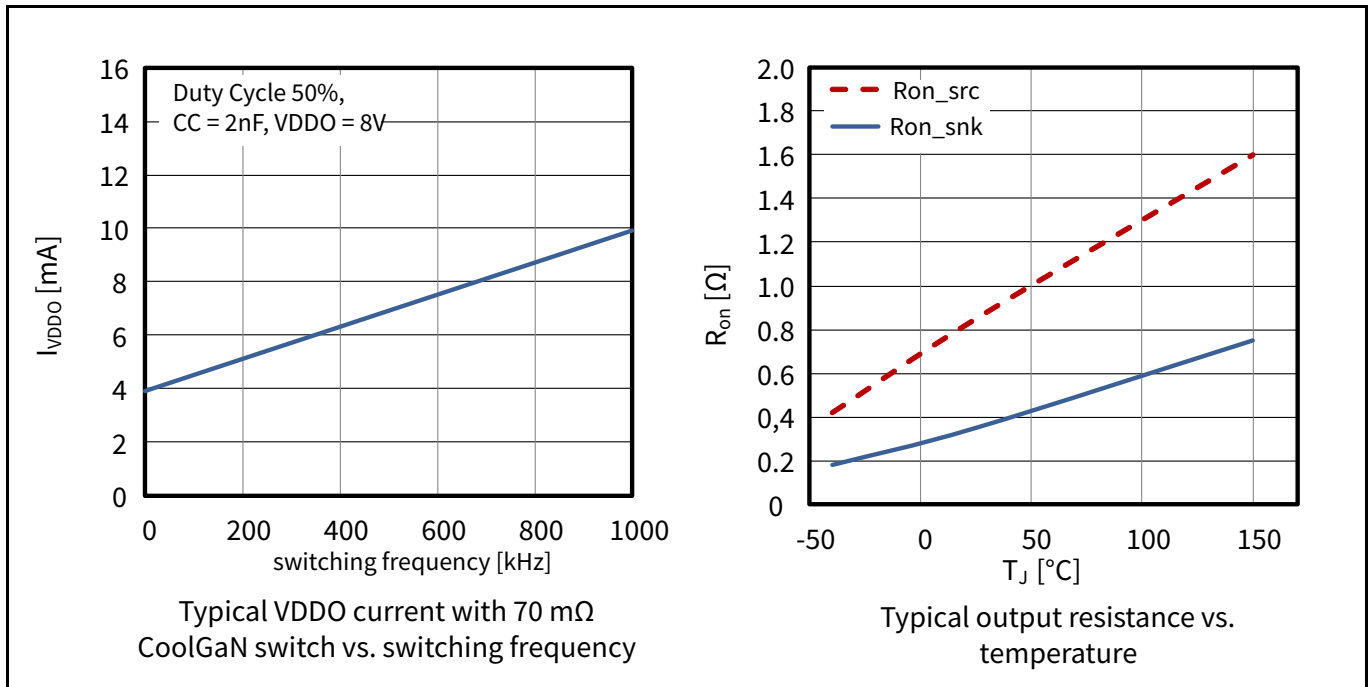

Figure 11 Supply current VDDO (with load) and output resistance

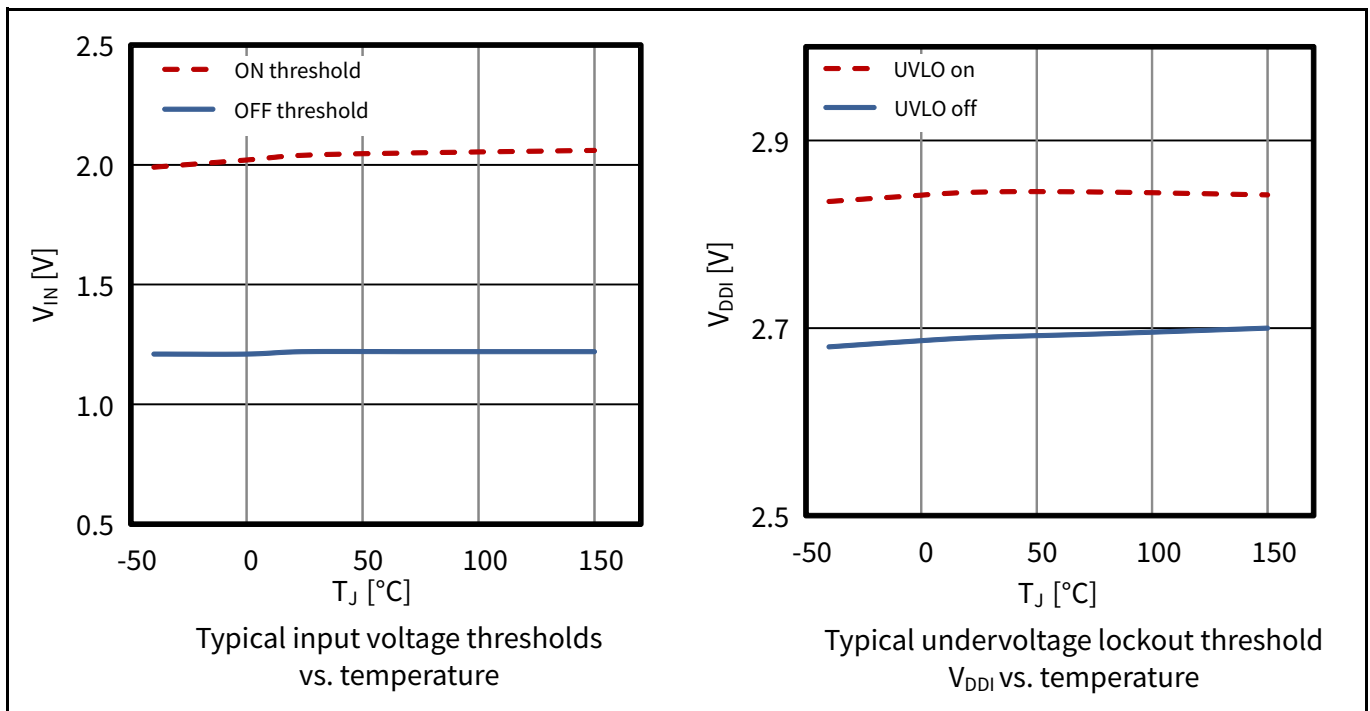

Figure 12 Logic input thresholds and  $V_{DDI}$  UVLO

Typical characteristics

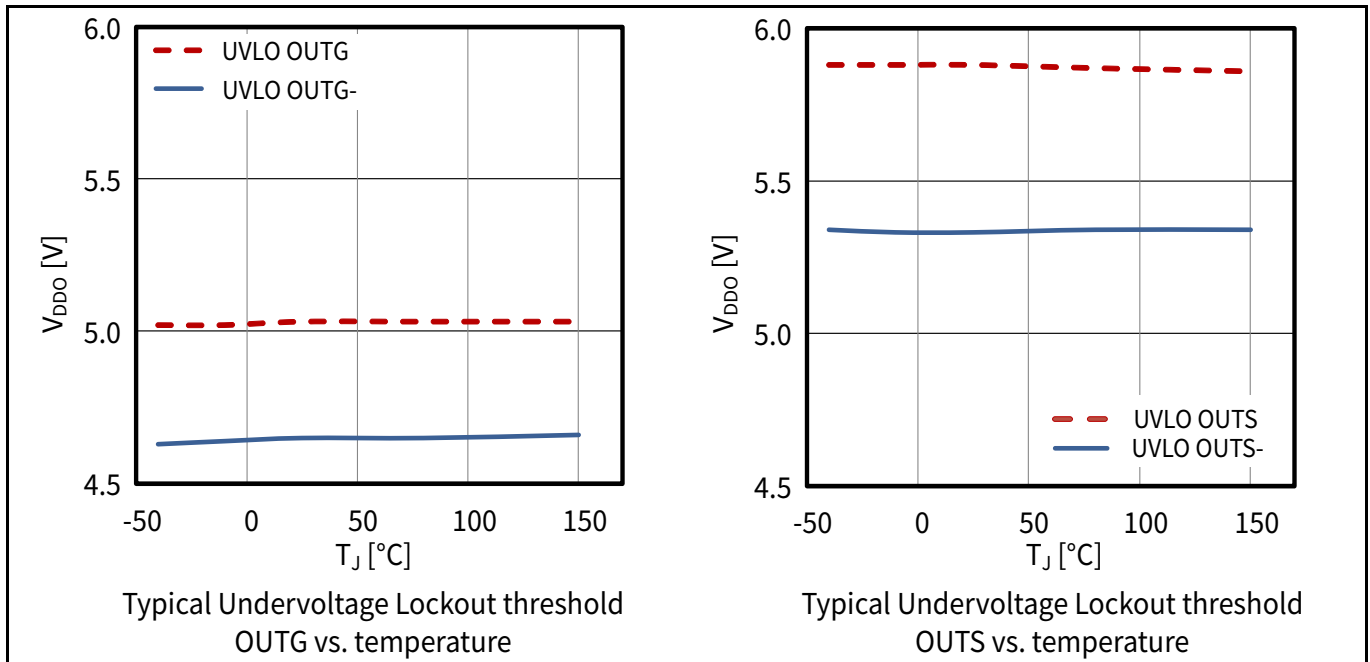

Figure 13 Output UVLO

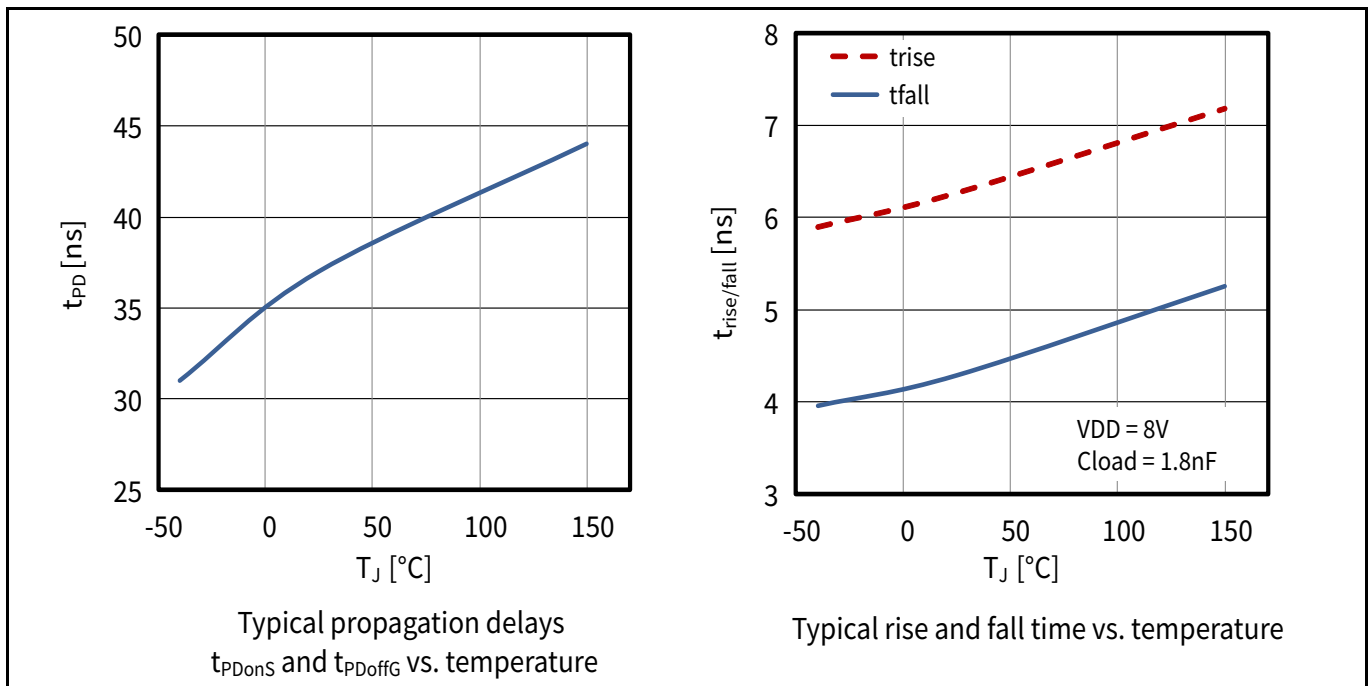

Figure 14 Propagation delay and rise / fall time

Typical characteristics

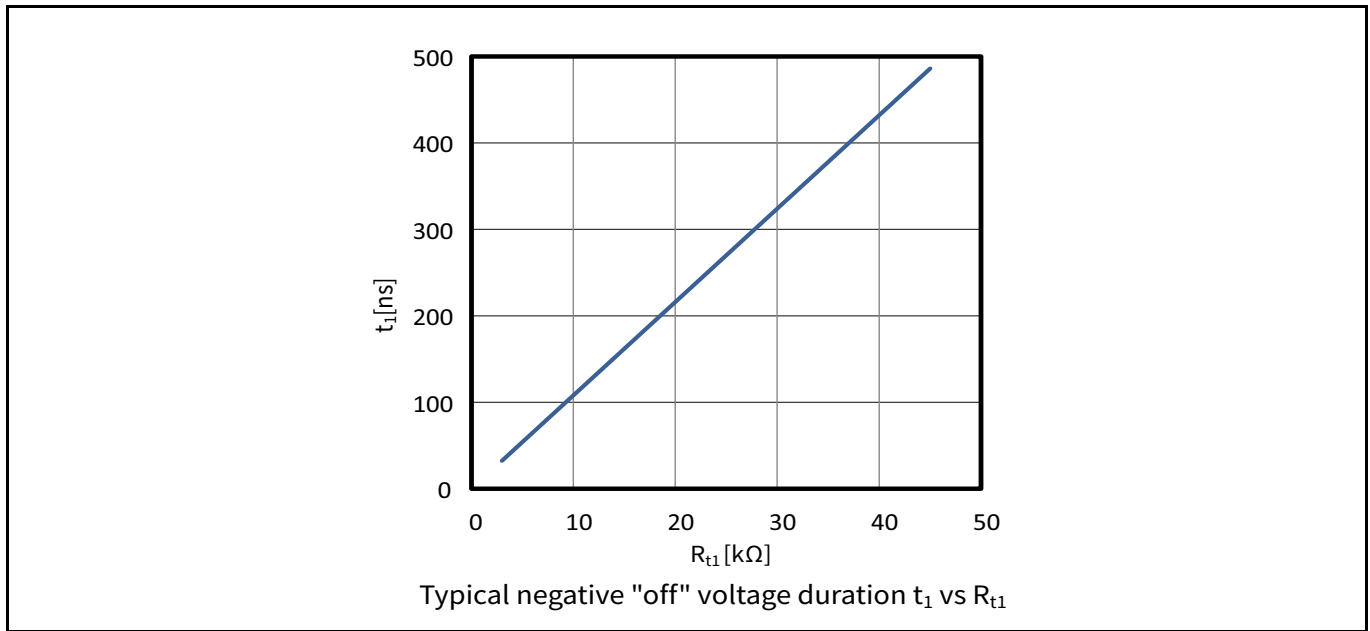

Figure 15 Typical negative "off" voltage duration  $t_1$  vs.  $R_{t1}$

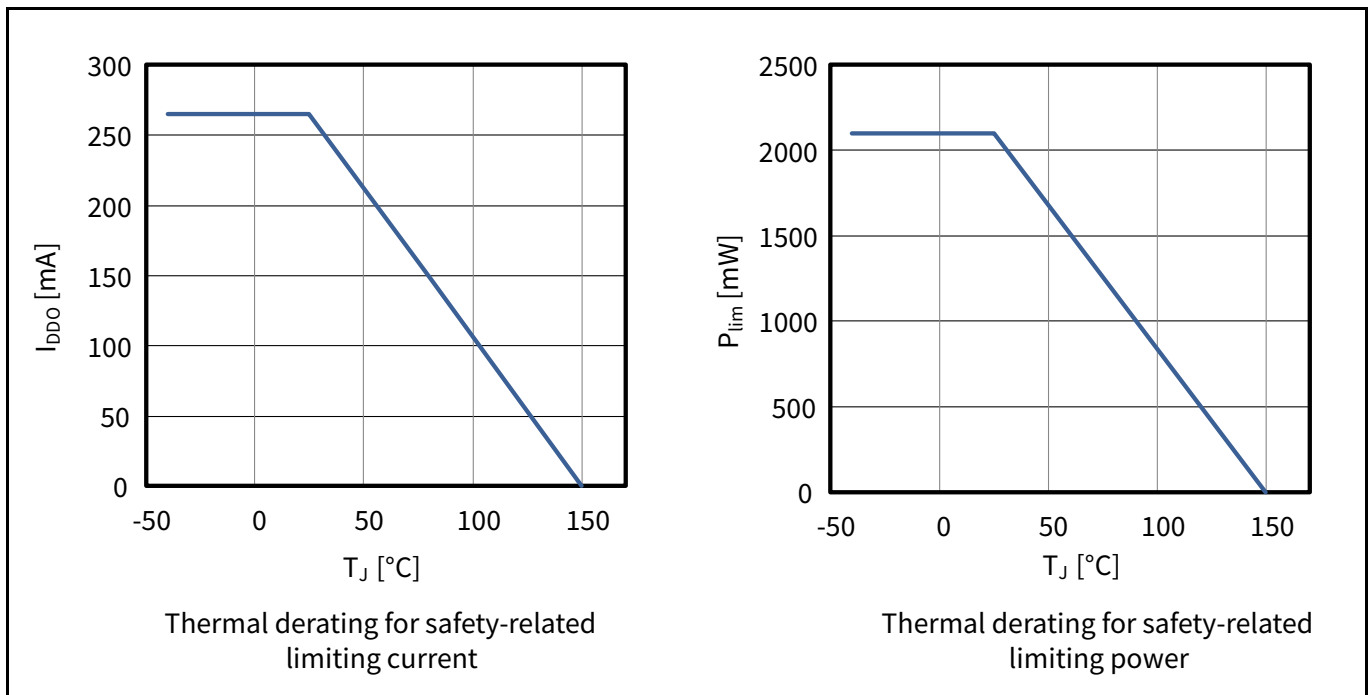

Figure 16 Thermal derating curves

**Isolation specifications**

**7 Isolation specifications**

The following tables summarize the package-specific isolation characteristics and test methods. For reinforced isolation, the regulatory tests described in the component and system standards are applied; functional isolation is guaranteed by the specified in-house test methods.

As soon as the regulatory certificates are available, the reference and / or documents will become available for public download on the Infineon website.

As finally creepage and clearance distances are influenced by PCB layout, it is the customer's responsibility to verify the respective requirements on system level.

**7.1 Functional isolation specifications**

**7.1.1 Functional isolation in PG-TFLGA-13-1 package (1EDF5673K)**

**Table 11 Functional isolation input-to-output (PG-TFLGA-13-1)**

Parameter	Symbol	Values			Unit	Note or Test Condition
		Min.	Typ.	Max.		
Functional isolation test voltage	$V_{IO}$	1500	–	–	$V_{DC}$	impulse test >10 ms, production tested
Maximum isolation working voltage	$V_{IOWM}$	460	–	–	$V_{RMS}$	according to IEC 60664-1 (PD 2; MG II)
Package clearance	CLR	–	3.4	–	mm	shortest distance over air, from any input pin to any output pin
Package creepage	CPG	–	3.4	–	mm	shortest distance over surface, from any input pin to any output pin
Common Mode Transient Immunity	CMTI	200	–	–	V/ns	according to VDE V0884-10, static and dynamic test
Capacitance input-to-output	$C_{IO}$	–	2	–	pF	–
Resistance input-to-output	$R_{IO}$	–	>1000	–	MΩ	–

**Isolation specifications**

**Table 12 Package characteristics (PG-TFLGA-13-1)**

Parameter	Symbol	Values			Unit	Note or Test Condition
		Min.	Typ.	Max.		
Comparative tracking Index of package mold	CTI	400	–	600	V	according to DIN EN 60112 (VDE 0303-11)
Material group	–	–	II	–	–	according to IEC 60112

**7.1.2 Functional isolation in NB PG-DSO-16-11 package (1EDF5673F)**

**Table 13 Functional isolation input-to-output (NB PG-DSO-16-11)**

Parameter	Symbol	Values			Unit	Note or Test Condition
		Min.	Typ.	Max.		
Functional isolation test voltage	$V_{IO}$	1500	–	–	$V_{DC}$	impulse test > 10 ms, sample tested
Maximum isolation working voltage	$V_{IOWM}$	510	–	–	$V_{RMS}$	according to IEC 60664-1 (PD2; MG II) <sup>1)</sup>
Package clearance	CLR	–	4.0	–	mm	shortest distance over air, from any input pin to any output pin
Package creepage	CPG	–	4.0	–	mm	shortest distance over surface, from any input pin to any output pin
Common Mode Transient Immunity	CMTI	200	–	–	V/ns	according to VDE V0884-10, static and dynamic test
Capacitance input-to-output <sup>1)</sup>	$C_{IO}$	–	2	–	pF	–
Resistance input-to-output <sup>1)</sup>	$R_{IO}$	–	>1000	–	MΩ	–

1) verified by design, not tested in production

**Table 14 Package characteristics (NB PG-DSO-16-11)**

Parameter	Symbol	Values			Unit	Note or Test Condition
		Min.	Typ.	Max.		
Comparative tracking Index of package mold	CTI	400	–	600	V	according to DIN EN 60112 (VDE 0303-11)
Material group	–	–	II	–	–	according to IEC 60112

**Isolation specifications**

**7.2 Reinforced isolation in WB PG-DSO-16-30 package (1EDS5663H)**

**Table 15 Input-to-output isolation specification according to VDE0884-10 (WB PG-DSO-16-30)**

Parameter	Symbol	Values			Unit	Note or Test Condition
		Min.	Typ.	Max.		
Maximum transient isolation voltage	$V_{IOTM}$	8000	–	–	$V_{pk}$	qualification for $t = 60$ s; production test with $V_{IOTM\_test} = V_{IOTM} * 1.2$ for $t = 1$ s
Maximum repetitive peak isolation voltage	$V_{IORM}$	1420	–	–	$V_{pk}$	Time Dependent Dielectric Breakdown test method
Maximum isolation working voltage	$V_{IOWM}$	1420 1000	– –	– –	$V_{DC}$ $V_{RMS}$	
Partial discharge voltage	$V_{PD}$	4500	–	–	$V_{pk}$	production test for $t = 1$ s, partial discharge $Q_{PD} < 5$ pC
Maximum surge isolation voltage	$V_{IOSM}$	6250	–	–	$V_{pk}$	$V_{IOSM\_test} = 1.6 \times V_{IOSM} > 10$ kV <sub>pk</sub> ; sample tested <sup>1)</sup>
Package clearance	CLR	–	8.0	–	mm	from any input pin to any output pin
Package creepage	CPG	–	8.0	–	mm	from any input pin to any output pin
Overvoltage category per IEC 60664-1 table F.1	–	I	–	IV		rated mains voltage $\leq 150 V_{RMS}$
		I	–	III		$\leq 300 V_{RMS}$
		I	–	II		$\leq 600 V_{RMS}$
Capacitance input-to-output	$C_{IO}$	–	2	–	pF	–
Resistance input-to-output	$R_{IO}$	–	>1000	–	M $\Omega$	–
Common Mode Transient Immunity	CMTI	200	–	–	V/ns	input to output static and dynamic; sample test

1) surge pulse tests applied according to IEC60065-10.1 (Ed 8.0 2014), 61000-4-5, 60060-1 waveforms (1.2  $\mu$ s slope, 50  $\mu$ s decay)

**Table 16 Reinforced isolation package characteristics (WB PG-DSO-16-30)**

Parameter	Symbol	Values			Unit	Note or Test Condition
		Min.	Typ.	Max.		
Comparative Tracking Index of package mold	CTI	400	–	600	V	according to DIN EN 60112 (VDE 0303-11)
Material group	–	–	II	–	–	according to IEC 60112
Pollution degree	–	–	2	–	–	–
Climatic category	–	–	40/125/21	–	–	–

**Isolation specifications**

**Table 17 Reinforced input-to-output isolation according to UL1577 Ed 5 (WB PG-DSO-16-30)**

Parameter	Symbol	Values			Unit	Note or Test Condition
		Min.	Typ.	Max.		
Withstand isolation voltage	$V_{ISO}$	5700	–	–	$V_{RMS}$	$V_{ISO} = 5700 V_{RMS}$ for $t = 60$ s (qualification); $V_{ISO\_test} > 1.2 \times V_{ISO} = 6840$ V for $t = 1$ s

**7.3 Safety-limiting values**

**Table 18 Reinforced isolation safety-limiting values as outlined in VDE-0884-10 (WB PG-DSO-16-30)**

Parameter	Side	Values			Unit	Note or Test Condition
		Min.	Typ.	Max.		
Safety supply power	Input	–	–	20.0	mW	$R_{thJA} = 59$ K/W <sup>1)</sup> , $T_A = 25^\circ\text{C}$ , $T_J = 150^\circ\text{C}$
	Output	–	–	2100	mW	
	Total	–	–	2120	mW	
Safety supply current	Output	–	–	265	mA	$R_{thJA} = 59$ K/W <sup>1)</sup> , $V_{DDO} = 8$ V, $T_A = 25^\circ\text{C}$ , $T_J = 150^\circ\text{C}$
Safety temperature	$T_s$	–	–	150	°C	$T_s = T_{J,max}$

1) Calculated with the  $R_{th}$  of WB-DSO-16-30 package (see [Table 4](#))

According to VDE0884-10 and UL1577, safety-limiting values define the operating conditions under which the isolation barrier can be guaranteed to stay unaffected. This corresponds with the maximum allowed junction temperature, as temperature-induced failures might cause significant overheating and eventually damage the isolation barrier.



# GaN EiceDRIVER™ product family

## GaN gate driver

### Application circuit

#### 8.1 Dimensioning guidelines

Due to low output impedance, high current limits and fast transients, the driver output stages can be regarded to behave like ideal switches. Thus half-bridge switching dynamics are exclusively and predictably controlled by the passive external components in the gate loop, allowing an easy adaptation to different applications and switch sizes.

As a first step in dimensioning these components the intended initial negative gate voltage  $-V_N$  has to be defined. The correlation between  $V_N$ ,  $V_{DDO}$  and  $C_C$  as given in Equation (2.1) is graphically depicted in Figure 18 for a hard-switched 70 mΩ CoolGaN™ transistor.

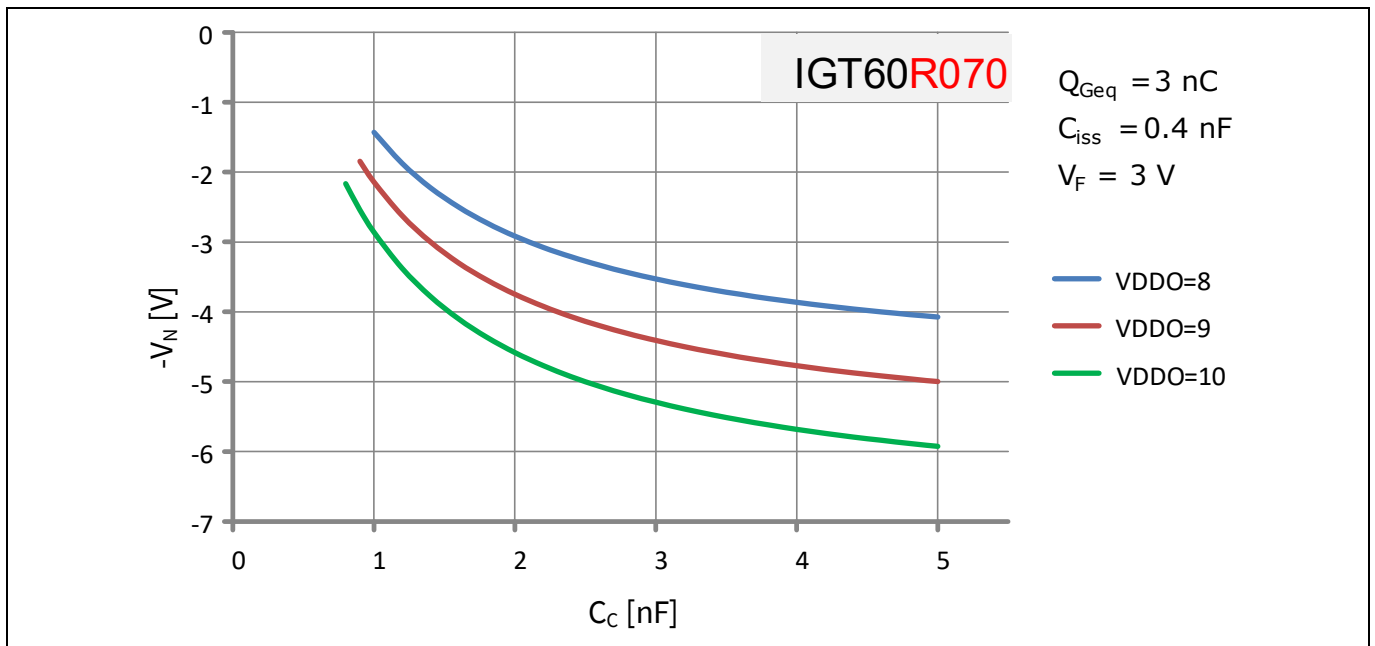

Figure 18  $-V_N$  as a function of  $V_{DDO}$  and  $C_C$  for hard-switched 70 mΩ CoolGaN™

A typical choice for  $-V_N$  could be  $-4$  V for hard-switched and  $-2$  V for soft-switched applications, respectively. Additionally, due to the low GaN threshold voltage, even under worst-case conditions  $-V_N$  should never be allowed to become positive. This requirement defines the minimum coupling capacitance  $C_{Cmin}$ . Under typical conditions  $C_{Cmin}$  then in fact generates a  $V_N$  of about 2 V, and thus this capacitance value can be recommended to be used in soft-switching topologies. Beside  $C_{Cmin}$ , Table 19 also summarizes recommended values for  $C_{Chs}$ , the coupling capacitance in hard-switching topologies, and resistor  $R_{ss}$  for different CoolGaN™ switches (currently 70 and 190 mΩ).

Table 19 Recommended values of  $C_{Cmin}$ ,  $C_{Chs}$  and  $R_{ss}$

$V_{DDO}$ [V]	IGx60R070x (70 mΩ)			IGx60R190x (190 mΩ)		
	$C_{Cmin}$ [nF]	$C_{Chs}$ [nF]	$R_{ss}$ [kΩ]	$C_{Cmin}$ [nF]	$C_{Chs}$ [nF]	$R_{ss}$ [kΩ]
8	1.8	3.3	0.56	1	1.8	1.2
10	1.2	1.8	0.82	0.8	1	1.8

The application circuit of Figure 17 uses different gate resistors for the "on" and "off" gate loops by introducing resistor  $R_{off}$  and (Schottky-)diode SD. The values of  $R_{tr}$  and  $R_{off}$  define the respective peak gate currents and thus switching times according to Equation (2.2). Due to the basic trade-off between switching time and inductive voltage overshoot, parasitic power and gate loop inductances have a strong influence on the optimum values of the gate resistors. For a 70 mΩ CoolGaN™ switch they are typically in the 5 to 20 Ω range for  $R_{tr}$ , whereas 2 to 5 Ω are a reasonable choice for  $R_{off}$ .

# GaN EiceDRIVER™ product family

## GaN gate driver

### Layout guidelines

## 9 Layout guidelines

For any fast-switching power system the PCB layout is crucial to achieve optimum performance. Among the many existing rules, recommendations, guidelines, tips and tricks, the following are of highest importance:

- minimize power loop inductance, the most critical limitation of switching speed due to the unavoidable voltage overshoots generated by fast current commutation
- use low-ESR decoupling capacitances for the driver supply voltages and place them as close as possible to the driver (in the layout proposals below the output capacitance has been split and connected to both supply pins)
- strictly avoid any additional coupling capacitance between input and output pins due to PCB layout (see [Chapter 3.7](#))

Respective layout proposals for the immediate driver surroundings are given in [Figure 19](#), [Figure 20](#) and [Figure 21](#) for the different available package types.

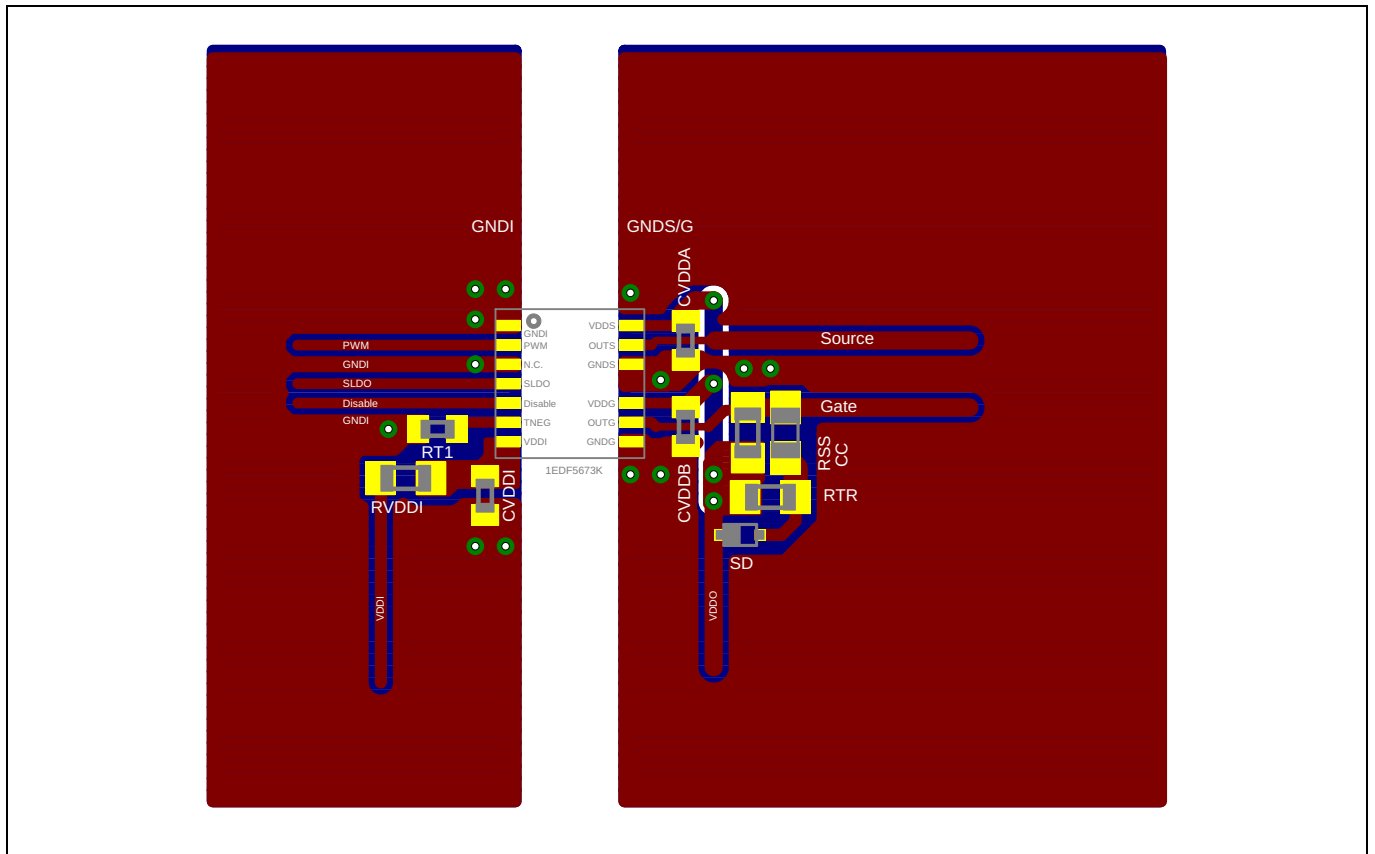
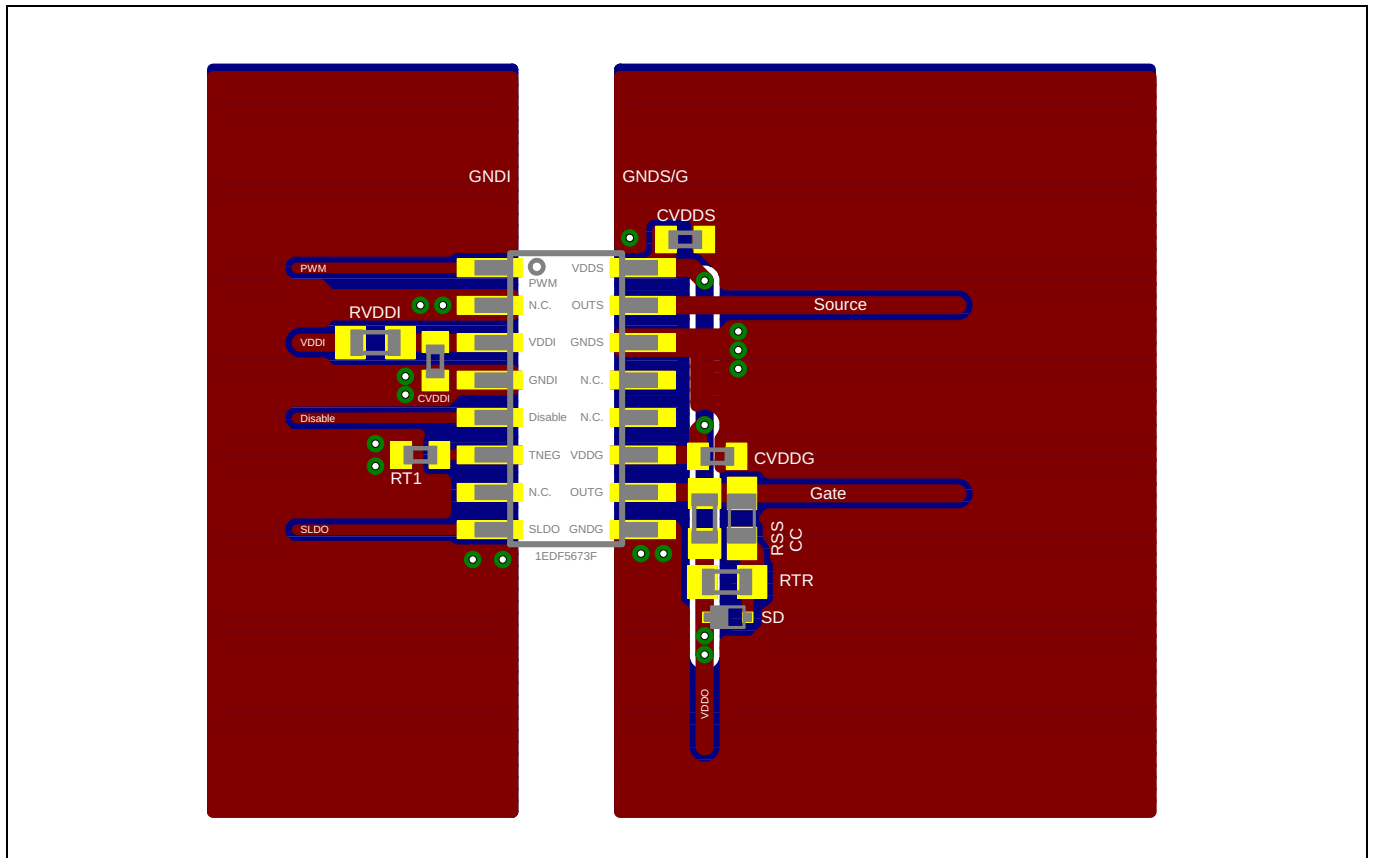

**Figure 19** Layout recommendation for PG-TFLGA-13-1 package

# GaN EiceDRIVER™ product family

## GaN gate driver

### Layout guidelines



**Figure 20** Layout recommendation for PG-DSO-16-11 package

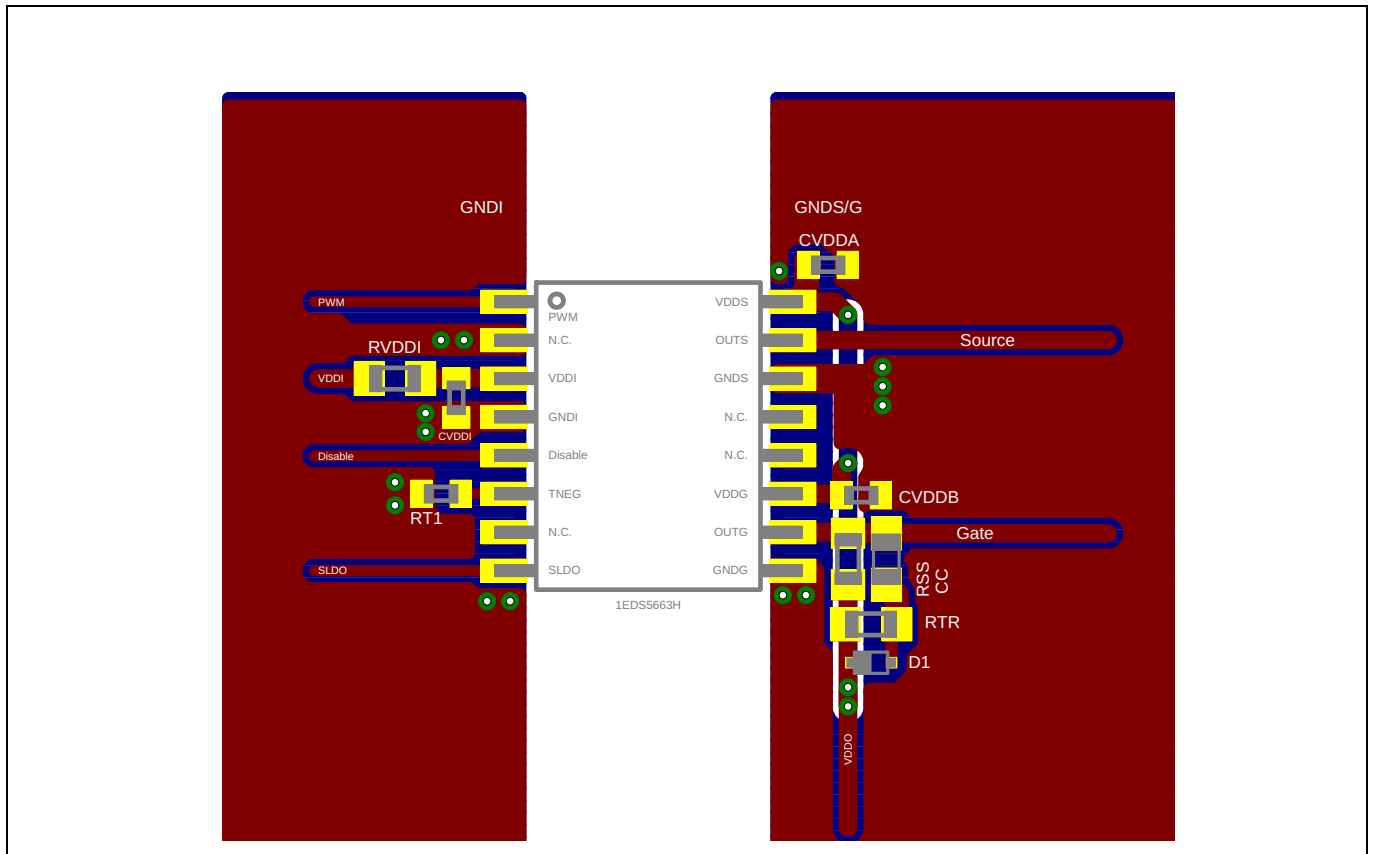

**Figure 21** Layout recommendation for PG-DSO-16-30 package

# GaN EiceDRIVER™ product family

## GaN gate driver

### Package outline dimensions

## 10 Package outline dimensions

The following package versions are available.

- an area optimized 5 x 5 mm<sup>2</sup> PG-TFLGA-13-1
- an NB PG-DSO-16-11 package with typ. 4 mm creepage input to output
- a WB PG-DSO-16-30 package with typ. 8 mm creepage input to output

Note: For further information on package types, recommendation for board assembly, please go to <https://www.infineon.com/packages>

### 10.1 Package PG-TFLGA-13-1

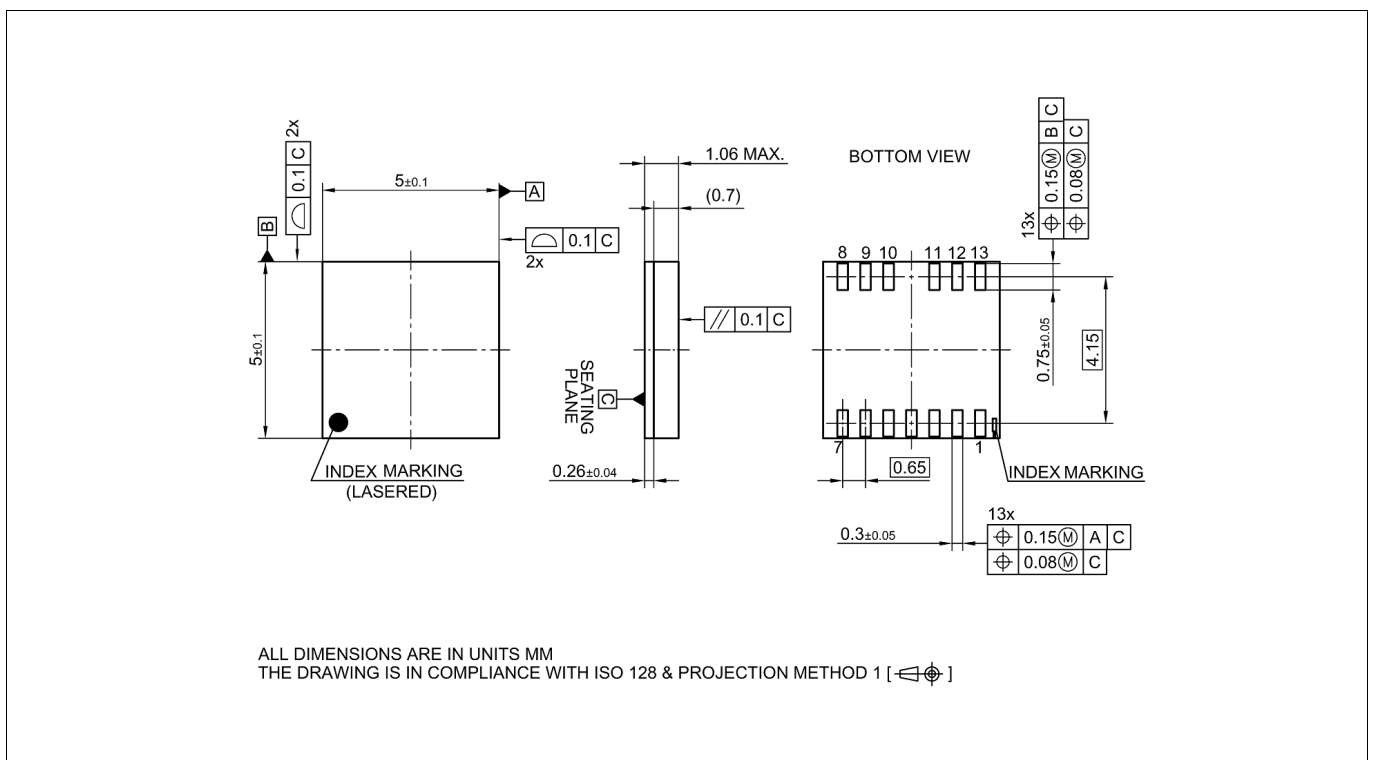

Figure 22 PG-TFLGA-13-1 outline

# GaN EiceDRIVER™ product family

## GaN gate driver

### Package outline dimensions

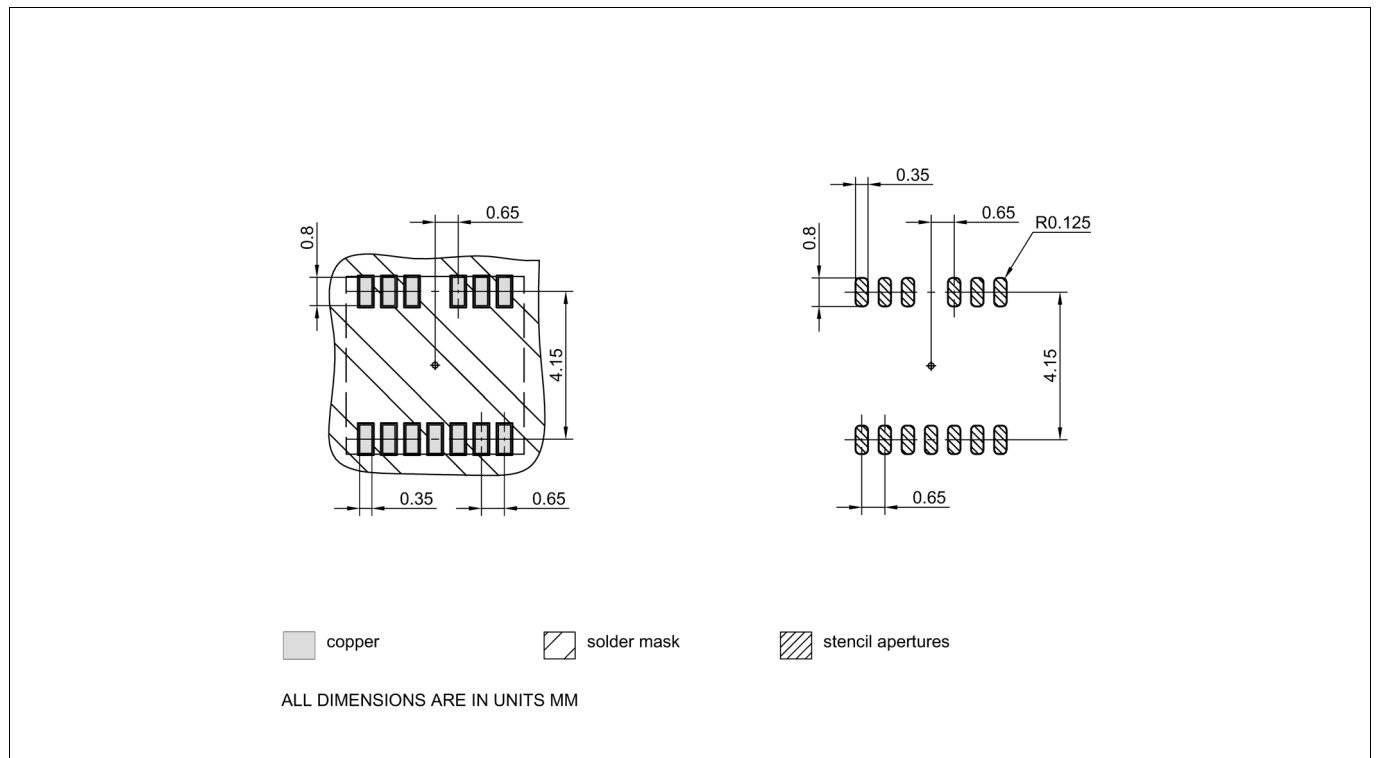

Figure 23 PG-TFLGA-13-1 footprint

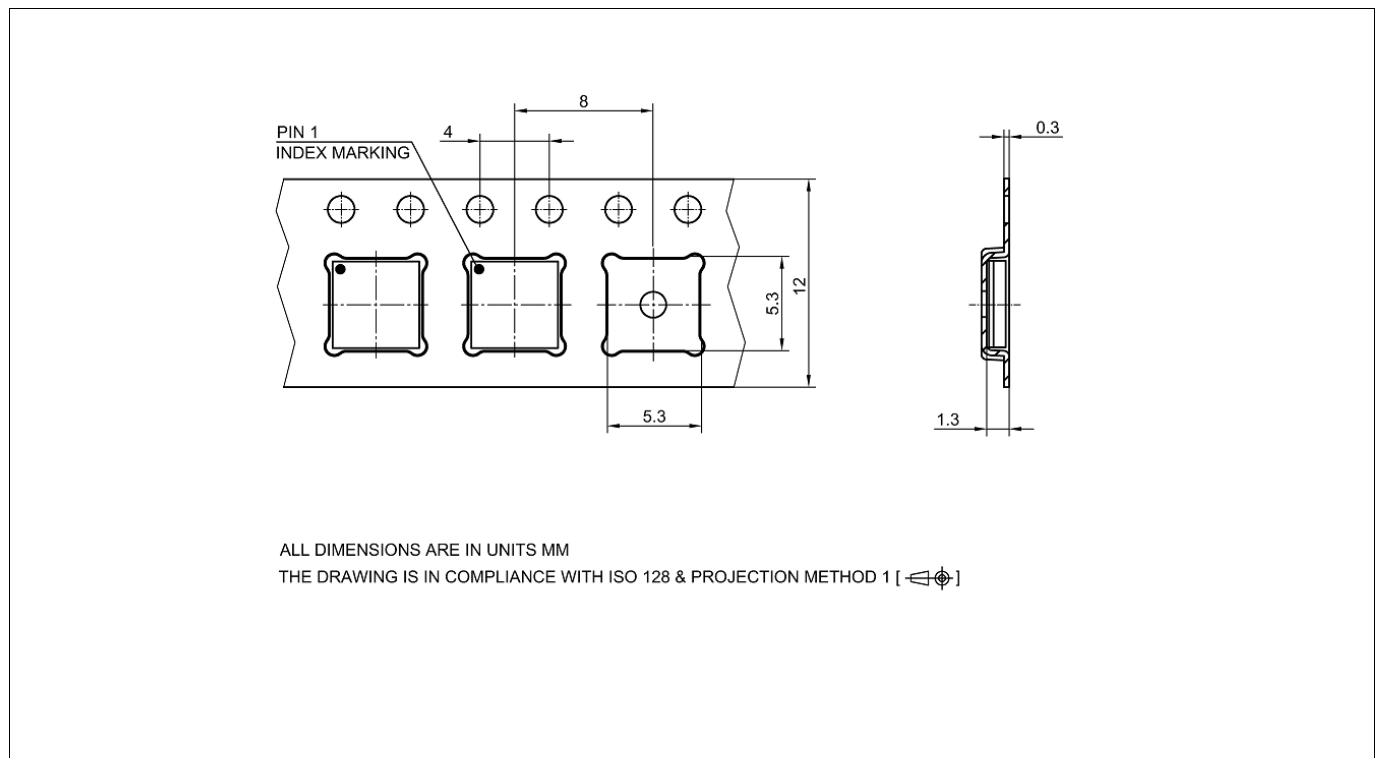

Figure 24 PG-TFLGA-13-1 packaging







# GaN EiceDRIVER™ product family

## GaN gate driver

---

### Device numbers and markings

## 11 Device numbers and markings

**Table 20** Device numbers and markings

<b>Part number</b>	<b>Package</b>	<b>Orderable part number (OPN)</b>	<b>Device marking</b>
1EDF5673K	PG-TFLGA-13-1	1EDF5673KXUMA1	1F5673B
1EDF5673F	PG-DSO-16-11	1EDF5673FXUMA1	1F5673B
1EDS5663H	PG-DSO-16-30	1EDS5663HXUMA1	1S5663B

# GaN EiceDRIVER™ product family

## GaN gate driver

### Revision History

## 12 Revision History

Page or Item	Subjects (major changes since previous revision)
<b>Rev. 2.4, 2021-11-09</b>	
Front page, <b>Table 1</b>	certification received for UL 1577
Front page, <b>Table 1</b>	certification received for EN 62368-1
<b>Table 1</b>	removed references to CSA and CQC (not anymore planned)
<b>Table 1</b>	removed reference to EN 60950-1 as it has been replaced by EN 62368-1
<b>Table 3, Table 5</b>	“Input supply voltage” → “Voltage at pin VDDI” to highlight that the supply voltage can be higher if the SLDO is activated
<b>Chapter 8.1</b>	the recommendation of adding a capacitance in parallel with the resistor $R_{t1}$ has been removed as per <b>Figure 17</b>
<b>Figure 17</b>	the recommended position of $R_{off}$ has been updated for stronger connection between MOSFET kelvin source and driver OUTS and improved gate noise clamping in OFF-state
<b>Rev. 2.3, 2020-10-22</b>	
<b>Isolation and safety approval</b>	corrected certificate names
<b>Table 1</b>	safety certification: added footnote and corrected certificate name
<b>Chapter 3.2</b>	updated package description
<b>Table 20</b>	updated
<b>Rev. 2.2, 2020-08-20</b>	
<b>Potential applications</b>	updated
<b>Table 1</b>	certification received for VDE0884-10
<b>Table 2</b>	update equation for Pin 6
<b>Table 2 and Chapter 3.7</b>	$t_1$ change → $t_1 = R_{t1} * 10.8 \text{ pF}$
<b>Chapter 3.7</b>	updated description text
<b>Table 5</b>	$C_{VDDI}$ max typo repaired
<b>Table 5</b>	Voltage at pins TNEG and SLDO → Voltage at pins SLDO and removed symbol for $V_{TNEG}$
<b>Table 8</b>	$t_1$ parameter condition change → 18 kΩ
<b>Table 8</b>	$t_1$ typ. value change → 194
<b>Figure 7</b>	corrected typo
<b>Figure 15</b>	updated
<b>Figure 17</b>	updated
<b>Figure 18</b>	updated
<b>Table 19</b>	updated
<b>Table 20</b>	new “B” marking: change in $t_1$ formula
<b>Rev. 2.10, 2019-02-11</b>	
<b>Page 1</b>	package diagrams update
<b>Page 1</b>	application diagram update

# GaN EiceDRIVER™ product family

## GaN gate driver

### Revision History

Page or Item	Subjects (major changes since previous revision)
<a href="#">Figure 1 &amp; Chapter 1</a>	repaired typo in pin config diagram and chapter
<a href="#">Equation (2.1)</a>	updated equation and relevant text
<a href="#">Figure 5</a>	added optional resistor and diode
<a href="#">Equation (2.2)</a>	updated to include $R_{off}$
<a href="#">Chapter 3.3.1</a>	added description of $I_{shunt}$
<a href="#">Chapter 3.3.3</a>	added chapter to describe power dissipation
<a href="#">Chapter 3.7</a>	added description of possibility to reduce shortening effect
<a href="#">Chapter 4.3</a>	updated footnote <sup>(2)</sup> about $V_{DDO}$ recommendation
<a href="#">Table 3</a>	max. $V_{DDI}$ : 3.7 V → 4.0 V
<a href="#">Table 5</a>	$T_A$ max. value 85°C → 125°C
<a href="#">Figure 17</a>	updated components and dimensions
<a href="#">Chapter 8.1</a>	added chapter on dimensioning guidelines
<a href="#">Figure 21</a>	format change
<a href="#">Chapter 10</a>	latest footprints, outlines and packaging
<b>Rev. 2.00, 2018-11-07</b>	
	Final datasheet created
<b>Rev. 1.00, 2018-10-25</b>	
	Initial version available

## Trademarks

All referenced product or service names and trademarks are the property of their respective owners.

**Edition 2021-11-09**

**Published by**

**Infineon Technologies AG**

**81726 Munich, Germany**

**© 2021 Infineon Technologies AG.**

**All Rights Reserved.**

**Do you have a question about any aspect of this document?**

**Email: [erratum@infineon.com](mailto:erratum@infineon.com)**

**Document reference**

**1EDF5673K, 1EDF5673F, 1EDS5663H**

## IMPORTANT NOTICE

The information given in this document shall in no event be regarded as a guarantee of conditions or characteristics ("Beschaffheitsgarantie").

With respect to any examples, hints or any typical values stated herein and/or any information regarding the application of the product, Infineon Technologies hereby disclaims any and all warranties and liabilities of any kind, including without limitation warranties of non-infringement of intellectual property rights of any third party.

In addition, any information given in this document is subject to customer's compliance with its obligations stated in this document and any applicable legal requirements, norms and standards concerning customer's products and any use of the product of Infineon Technologies in customer's applications.

The data contained in this document is exclusively intended for technically trained staff. It is the responsibility of customer's technical departments to evaluate the suitability of the product for the intended application and the completeness of the product information given in this document with respect to such application.

For further information on technology, delivery terms and conditions and prices, please contact the nearest Infineon Technologies Office ([www.infineon.com](http://www.infineon.com)).



## WARNINGS

Due to technical requirements products may contain dangerous substances. For information on the types in question please contact your nearest Infineon Technologies office.

Except as otherwise explicitly approved by Infineon Technologies in a written document signed by authorized representatives of Infineon Technologies, Infineon Technologies' products may not be used in any applications where a failure of the product or any consequences of the use thereof can reasonably be expected to result in personal injury.

## Looking for pricing, stock, or lifecycle information?

Click below to explore more details on WIN SOURCE:

-  [View 1EDF5673FXUMA1 on WIN SOURCE](#)
-  [Infineon Technologies Information](#)

## Optimize Your Supply Chain with WIN SOURCE Solutions

-  Global Sourcing Solution
-  Obsolete Management
-  Cost Control Management
-  Shortage Management
-  Alternative Solution
-  Excess Inventory Management