



**THE DATASHEET OF  
410-357-B**



## JTAG-SMT3-NC Reference Manual

Revised September 6, 2018

This manual applies to the JTAG-SMT3-NC rev. A

### Overview

The Joint Test Action Group (JTAG)-SMT3-NC is a compact, complete, and fully self-contained surface-mount programming module for Xilinx field-programmable gate arrays (FPGAs). The module can be accessed directly from all Xilinx Tools, including iMPACT, ChipScope™, Vivado, and EDK. Users can load the module directly onto a target board and reflow it like any other component.

The JTAG-SMT3-NC uses a 3.3V main power supply and independent Vref supplies to drive the JTAG and UART signals. All JTAG signals use high speed 24mA three-state buffers that allow signal voltages from 1.8V to 5.5V, and bus speeds up to 30MBit/sec. All UART signals use high speed 24mA buffers that allow signal voltages from 1.8V to 5.5V and bus speeds up to 12Mbaud. The JTAG bus can be shared with other devices as the SMT3-NC signals are held at high impedance, except when actively driven during programming. The SMT3-NC module is CE certified and fully compliant with EU RoHS and REACH directives. The module routes the USB D+ (DP) and D- (DM) signals out to pads, providing the system designer with the ability to choose the type of USB connector and its location on the system board.



*The JTAG-SMT3-NC.*

- Small, complete, all-in-one JTAG programming/debugging solution for Xilinx FPGAs with UART side channel
- Compatible with Xilinx Tools
- High-Speed USB 2.0 port that can drive JTAG bus up to 30Mbit/sec (frequency settable by user)
- Open drain buffer on PS\_SRST\_B pin allows debugging software to reset the processor core of Xilinx's Zynq® platform
- Dual channel USB controller provides simultaneous access to both JTAG and UART interfaces
- Separate Vref for JTAG and UART signals allows each interface to operate at difference voltages (1.8V to 5.5V)
- Small form-factor surface-mount module can be directly loaded on target boards
- USB D+ and D- signals routed to pads, allowing USB connector to be placed anywhere on the host PCB
- VBUS\_DETECT pin allows for reduced current consumption when the module isn't connected to a PC

Users can connect JTAG signals directly to the corresponding FPGA signals, as shown in Fig. 1. For best results, mount the module over a ground plane on the host PCB. Although users may run signal traces on top of the host PCB beneath the SMT3-NC, Digilent recommends keeping the area immediately beneath the SMT3-NC clear.

*Note: Keep the impedance between the SMT3-NC and FPGA below 100 Ohms to operate the JTAG at maximum speed. Note: If series resistors are used, they should be placed near the transmitting end in order to minimize reflections.*

In addition to supporting JTAG, the JTAG-SMT3-NC also features a UART Interface that allows communication with UART peripherals (see Fig. 2). The UART interface is presented as a virtual com port on the host PC, supports baud rates up to 12Mbaud, and has an independent voltage reference which allows it to interface with devices operating at voltages between 1.8V and 5.5V.

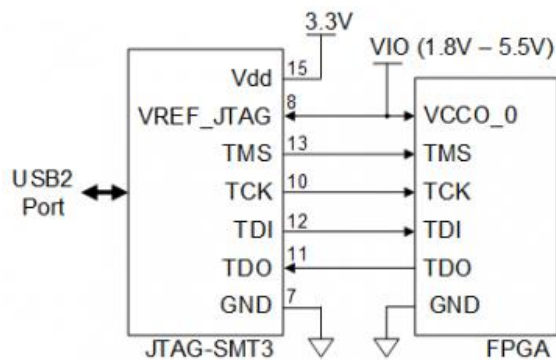

Figure 1. JTAG-SMT3 JTAG port connections.

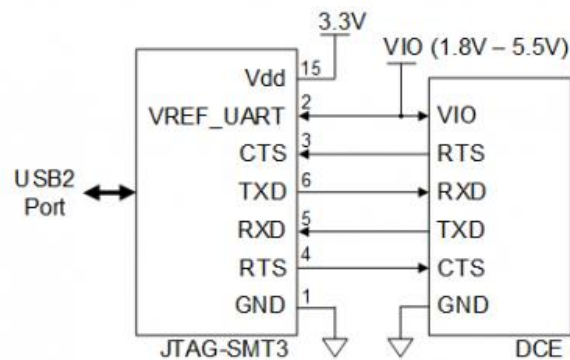

Figure 2. SMT3 UART port connections.

# 1 Software Support

The JTAG-SMT3-NC has been designed to work seamlessly with Xilinx’s ISE® (iMPACT, ChipScope, EDK, and eFuse) and Vivado tool suites. The most recent versions of ISE and Vivado include all of the drivers, libraries, and plugins necessary to communicate with the JTAG-SMT3-NC. At the time of writing, the following Xilinx software included support for the SMT3: Vivado 2017.1+, Vivado 2016.1+, Vivado 2015.1+, Vivado 2014.1+, and ISE 14.1+. The SMT3-NC is also compatible with ISE 13.1 - 13.4; however, these versions of ISE do not include all of the libraries, drivers, and plugins necessary to communicate with the SMT3-NC. In order to use the JTAG-SMT3-NC with these versions of ISE, version 2.5.2 or higher of the [Digilent Plugin for Xilinx Tools](#) package must be downloaded from the Digilent website and the ISE13 plugin must be manually installed as described in the included documentation.

In addition to working seamlessly with all Xilinx tools, [Digilent’s Adept software](#) and the Adept software development kit (SDK) support the SMT3-NC module. For added convenience, customers may freely download the SDK from Digilent’s website. This Adept software includes a full-featured programming environment and a set of public application programming interfaces (API) that allow user applications to directly drive the JTAG chain.

With the Adept SDK, users can create custom applications that will drive JTAG ports on virtually any device. Please see the Adept SDK reference manual for more information.

## 2 PS\_SRST\_B Pin

When customers use the JTAG-SMT3-NC to interface the scan chain of Xilinx’s Zynq platform, they should connect the PS\_SRST\_B pin of the SMT3-NC to the Zynq’s PS\_SRST\_B pin. This connection allows the Xilinx Tools to reset the Zynq’s processor core at various times during debugging operations. The PS\_SRST\_B pin on the SMT3-NC is driven by an open drain buffer that is capable of sinking up to 32mA of current. Customers who connect this pin must provide an external pull-up to the appropriate supply rail. A pull-up resistor between 1K - 100K Ohms is recommended. Please see the following “Application Examples” section for more information.

## 3 VBUS\_DETECT Pin

The VBUS\_DETECT pin is used by the USB controller to determine when VBUS is present. When a logic ‘0’ is detected on this pin, the USB controller is forced into suspend mode. This prevents the SMT3-MC from forcing current down the USB lines when the host or the hub is powered off. Additionally, it results in reduced current consumption from the module. Connect VBUS to the VBUS\_DETECT pin using a resistor divider, similar to the one in Fig. 3 shown below.

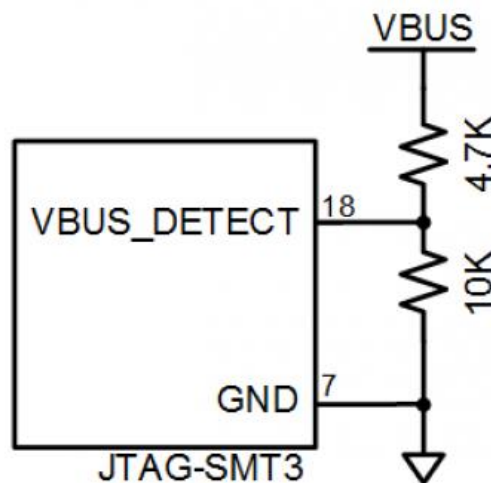

Figure 3. Connecting VBUS to the VBUS\_DETECT pin.

## 4 Application Examples

### 4.1 Example 1: Interfacing a Zynq-7000

Figure 4 demonstrates how to connect the JTAG-SMT3-NC to Xilinx’s Zynq-7000 silicon. Please note that VCCO\_0 and VCCO\_MIO1 may be powered by the same supply or by different supplies. The PS\_SRST\_B pin of the SMT3-NC is driven by an open drain buffer and therefore an external open drain buffer is not required to add an optional reset button.

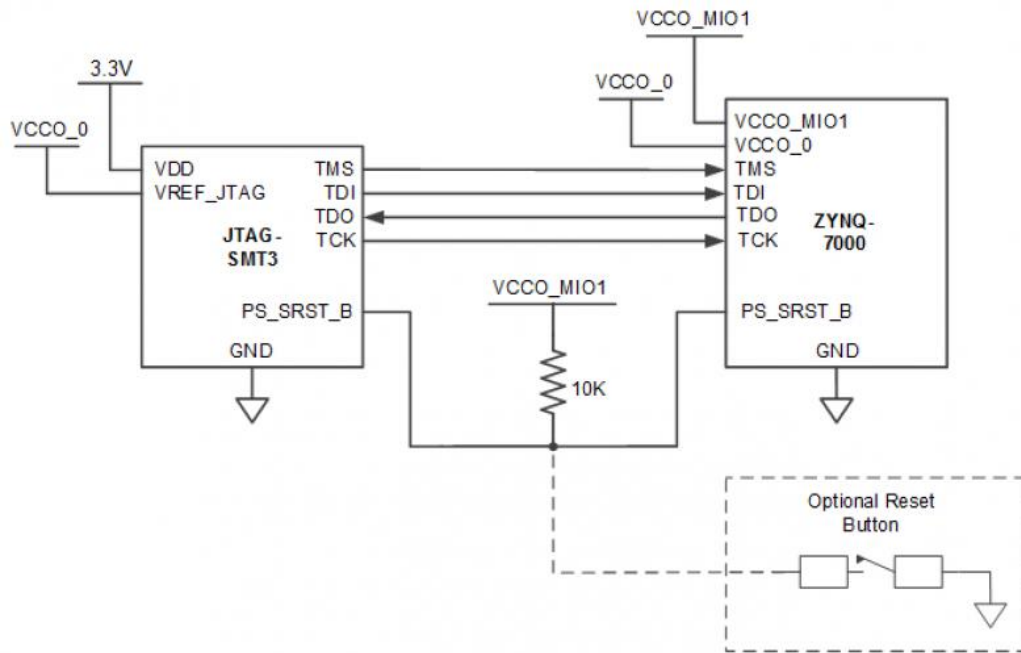

Figure 4. Zynq Application Example.

## 4.2 Example 2: Interfacing a Zynq-7000 while retaining the Xilinx JTAG Header

Figure 5 below demonstrates how to connect the JTAG-SMT3-NC to Xilinx’s Zynq-7000 silicon alongside Xilinx’s 14-pin JTAG header. In this example, an open drain buffer allows both the SMT3-NC and Xilinx JTAG Header to drive the PS\_SRST\_B pin, which may operate a different voltage than the Zynq’s JTAG pins.

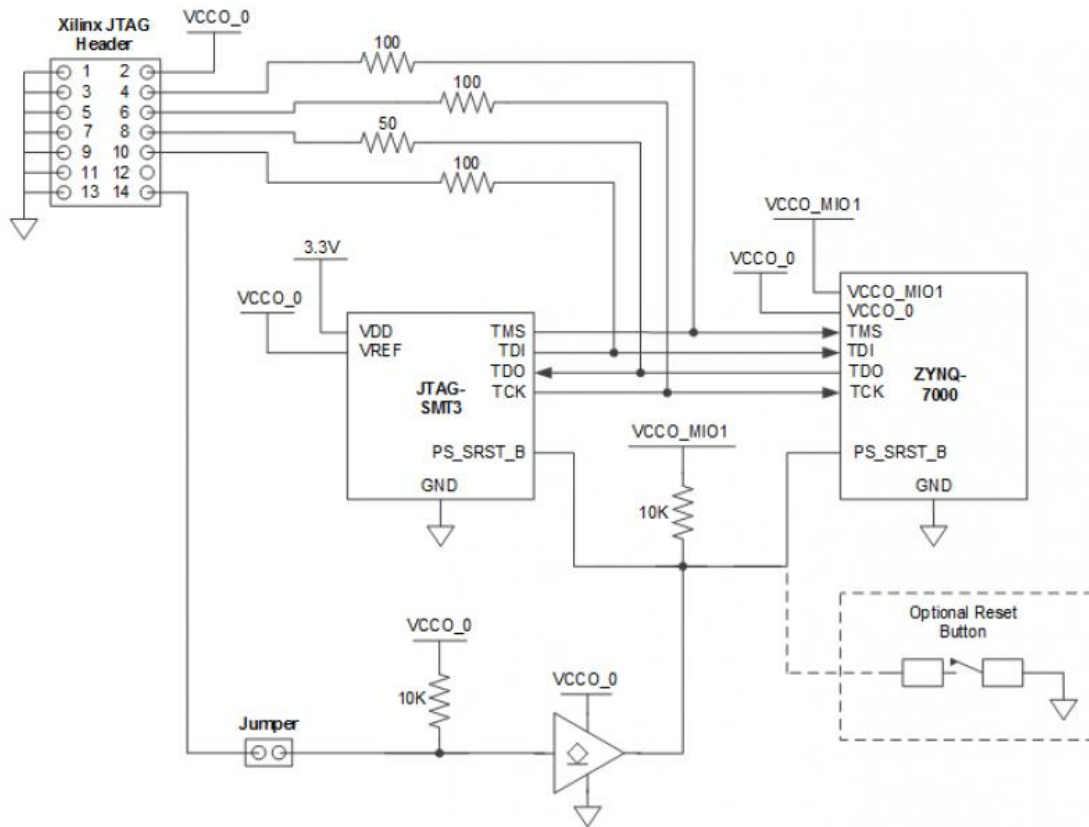

Figure 5. Open drain buffer allowing the SMT3 and JTAG Header to drive the PS\_SRST\_B pin.

## 5 Supported Target Devices

The JTAG-SMT3-NC is capable of targeting the following Xilinx devices:

- Xilinx FPGAs
- Xilinx Zynq-7000
- Xilinx CoolRunner™/CoolRunner-II CPLDs
- Xilinx Platform Flash ISP configuration PROMs<sup>1,2</sup>
- Select third-party SPI PROMs<sup>1,2</sup>
- Select third-party BPI PROMs<sup>1,2</sup>

The following devices **cannot** be targeted by the JTAG-SMT3-NC:

- Xilinx 9500/9500XL CPLDs
- Xilinx 1700 and 18V00 ISP configuration PROMs
- Xilinx FPGA eFUSE programming

Remote device configuration is not supported for the JTAG-SMT3-NC when used with Xilinx’s iMPACT software.

<sup>1</sup> — Note: Please see the “Introduction to Indirect Programming – SPI or BPI Flash Memory” help topic in iMPACT for a list of supported FPGA/PROM combinations.

<sup>2</sup> — Note: Please see the “Configuration Memory Support” section of Xilinx UG908 for a list of the FPGA/PROM combinations that Vivado supports.

## 5.1 Programming Solutions Comparison Chart

	JTAG-SMT3-NC	JTAG-SMT2	JTAG-SMT2-NC
Max Speed	30 MHz	30 MHz	30 MHz
Voltage Range	1.8V – 5V	1.8V – 5V	1.8V – 5V
Xilinx Native Support	ISE 14.1+ Vivado 2014.1	ISE 14.1+ Vivado 2013.1+	ISE 14.1+ Vivado 2013.1+
Xilinx Plug-in Support	ISE 13.1+	ISE 13.1+	ISE 13.1+
Digilent Adept Support	YES	YES	YES
PC Interface	USB	USB	USB
Onboard USB Connector	YES	YES	NO
Host Board Connector Interface	18-pad SMT	11-pad SMT	13-pad SMT
4-Wire JTAG	YES	YES	YES
2-Wire JTAG	NO	YES	YES
Zynq-7000 PS_SRST Support	YES	YES	YES
SPI Support	NO	YES	YES
Independent UART Channel	YES	NO	NO

## 6 Pinout Table

Pin Number	Pin Name	Pin Number	Pin Name
1	GND	10	TCK
2	VREF_UART	11	TDO
3	CTS	12	TDI
4	RTS	13	TMS
5	RXD	14	GND
6	TXD	15	VDD
7	GND	16	USB_DM
8	VREF_JTAG	17	USB_DP
9	PS_SRST_B	18	VBUS_DETECT

## 7 Mechanical Information

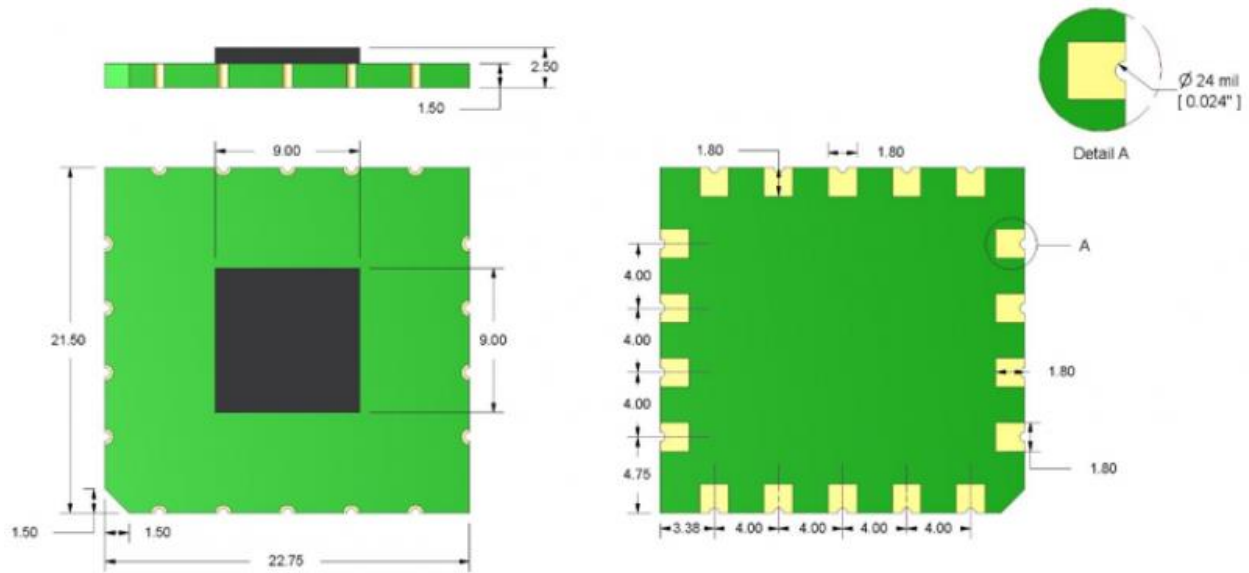

Figure 5. PCB spacing diagram.

Note: PCB dimensions have a tolerance of +/- 0.13mm.

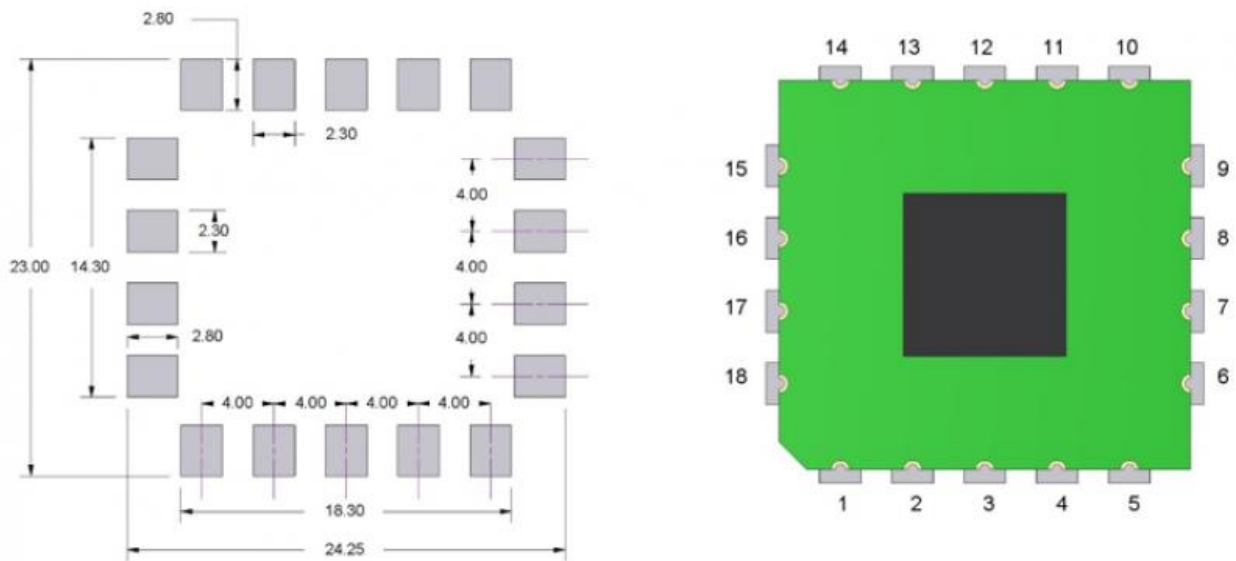

Figure 7. PCB pin spacing diagram.

Note: All dimensions are shown in millimeters.

## 8 General USB Signal Routing Guidelines

- Maintain a differential impedance of 90 Ohms between the DP and DM signals.
- Keep DP and DM trace lengths within 50 mils of each other.

- Minimize DP and DM signal trace length. Keeping the trace length below 3 inches is recommended.
- When possible, route DP and DM on the plane closest to the ground plane.
- When possible, avoid routing the DP and DM signals through vias. If vias cannot be avoided, then keep them small and place the DP and DM traces on the same layer.
- When possible, avoid routing other traces near DP and DM.
- When possible, minimize or avoid the use of bends in the DP and DM traces. If 90 degree bends are necessary, then use two 45 degree turns or an arc instead of a single 90 degree turn.
- Do NOT route DP or DM near oscillators, crystals, switching regulators, clock generators, or inductors.

## 8.1 Absolute Maximum Ratings

Symbol	Parameter	Condition	Min	Max	Unit
Vdd	Operating supply voltage		-0.3	4.0	V
Vref	I/O reference/supply voltage		-0.3	6	V
VIO	Signal Voltage		-0.3	6	V
I <sub>I,K</sub> , I <sub>O,K</sub>	TMS, TCK, TDI, TDO, TXD, RXD, RTS, CTS, PS_SRST_B DC Input/Output Diode Current	VIO < -0.3V VIO > 6V		-50 +20	mA
I <sub>OUT</sub>	DC Output Current			±50	mA
TSTG	Storage Temperature		-10	+60	°C
ESD	Human Body Model JESD22-A114			4000	V
	Charge Device Model JESD22-C101			2000	V

## 8.2 DC Operating Characteristics

Symbol	Parameter	Min	Typ	Max
Vdd	Operating supply voltage	2.97	3.3	3.63
VREF_JTAG	JTAG I/O reference/supply voltage	1.65	3.3	5.5
VREF_UART	UART I/O reference/supply voltage	1.65	3.3	5.5
TDO, RXD, CTS	Input High Voltage (VIH)	0.75 x Vref		5.5
	Input Low Voltage (VIL)	0		0.55
VBUS_DETECT	Input High Voltage (VIH)	2.0		Vdd
	Input Low Voltage (VIL)	0		0.8
TMS, TCK, TDI	Output High (VOH)	0.78 x Vref	0.95 x Vref	Vref
	Output Low (VOL)	0	0.05 x Vref	0.55
TXD, RTS	Output High (VOH)	0.75 x Vref		Vref
	Output Low (VOL)	0		0.55
PS_SRST_B	Output Low (VOL)	0		0.55
TA	Operating Temperature	-40		85
Symbol	Parameter	Min	Typ	Max

## 9 AC Operating Characteristics

The JTAG-SMT3-NC's JTAG signals operate according to the timing diagram in Fig. 7. The SMT3-NC supports JTAG/TCK frequencies from 30 MHz to 8 KHz at integer divisions of 30 MHz from 1 to 3750. Common frequencies include 30 MHz, 15 MHz, 10 MHz, 7.5 MHz, and 6 MHz (see Table 2). The JTAG/TCK operating frequency can be set within the Xilinx tools.

*Note: Please refer to Xilinx's iMPACT documentation for more information.*

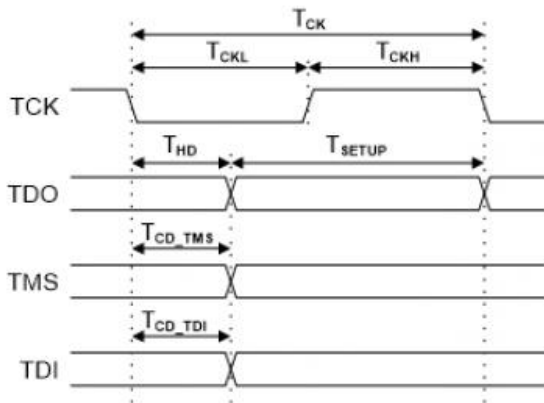

Figure 8. Timing diagram.

Symbol	Parameter	Min	Max
$T_{CK}$	$T_{CK}$ period	30ns	125 $\mu$ s
$T_{CKH}, T_{CKL}$	$T_{CLK}$ pulse width	15ns	62.5 $\mu$ s
$T_{CD\_TMS}$	$T_{CLK}$ to TMS	-1.5ns	12.35ns
$T_{CD\_TDI}$	$T_{CLK}$ to TDI	-0.5ns	8.15ns
$T_{SETUP}$	TDO Setup time	15.8ns	
$T_{HD}$	TDO Hold time	0ns	

Table 2. JTAG frequency support.

*Note: these parameters are specified for  $V_{ref} = 3.3V$ .*

## 10 Mounting to Host PCBs

The JTAG-SMT3-NC module has a moisture sensitivity level (MSL) of 3. It is suitable for reflow for up to 168 hours without additional drying.

The factory finishes the JTAG-SMT3-NC signal pads with the ENIG process using 2u" gold over 150u" electroless nickel. This makes the SMT3-NC compatible with most mounting and reflow processes (see Fig. 8). The binding force of the solder is sufficient to hold the SMT3-NC firmly in place, so mounting should require no additional adhesives.

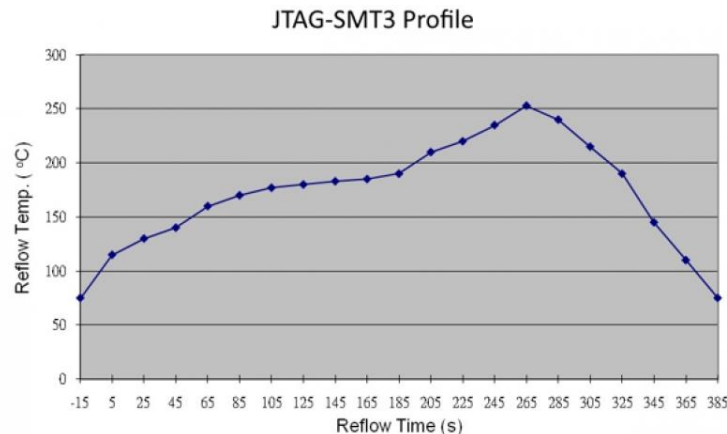
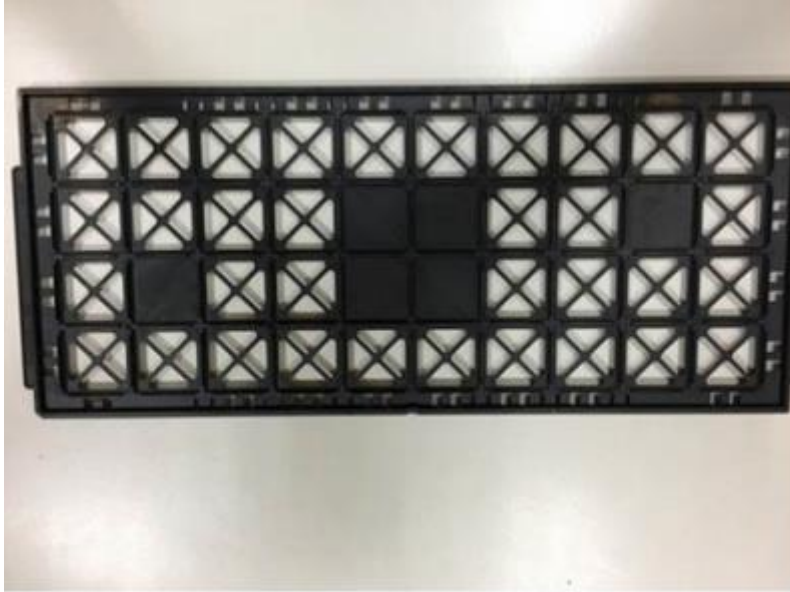

Figure 9. JTAG-SMT3 reflow temperature over time.

## 11 Packaging

Digilent ships quantities under 40pcs individually packaged in antistatic bags. Digilent will pack and ship larger quantities in groups of 40 positioned in an antistatic bake tray (see Fig. 10). Trays will be packaged in an anti-static vacuum sealed bag. We also offer to bake them before shipping for an additional cost per 40pc lot.



*Figure 10. JTAG-SMT3 shipping arrangement.*

## Looking for pricing, stock, or lifecycle information?

Click below to explore more details on WIN SOURCE:

 [View 410-357-B on WIN SOURCE](#)

 [Digilent, Inc. Information](#)

## Optimize Your Supply Chain with WIN SOURCE Solutions

-  Global Sourcing Solution
-  Obsolete Management
-  Cost Control Management
-  Shortage Management
-  Alternative Solution
-  Excess Inventory Management