



**THE DATASHEET OF
LTC1470ES8#TRPBF**



FEATURES

- Single 3.3V/5V Switch in 8-Pin SO Package
- Dual 3.3V/5V Switch in 16-Pin SO Package
- Built-In Current Limit and Thermal Shutdown
- Built-In Charge Pumps (No 12V Required)
- Extremely Low $R_{DS(ON)}$ MOSFET Switches
- Output Current Capability: 1A
- Inrush Current Limited (Drives 150 μ F Loads)
- Quiescent Current in Standby: 1 μ A
- No Parasitic Body Diodes
- Built-In XOR Function Eliminates "Glue" Logic
- Break-Before-Make Switching
- Controlled Rise and Fall Times
- Available in 8-Pin and 16-Pin SO Packages

APPLICATIONS

- Set Top Box/Open Cable
- Notebook Computers
- Palmtop Computers
- Pen-Based Computers
- Handi-Terminals
- 3.3V/5V Power Supply Switch

DESCRIPTION

The LTC[®]1470 switches the V_{CC} pins of a Personal Computer Memory Card International Association (PCMCIA) card slot between three operating states: OFF, 3.3V and 5V. Two low $R_{DS(ON)}$ N-channel power MOSFETs are driven by a built-in charge pump which generates a voltage higher than the supply voltage to fully enhance each switch when selected by the input control logic.

The LTC1470 inputs are compatible with industry standard PCMCIA controllers. A built-in XOR ensures that both switches are never on at the same time. This function also makes the LTC1470 compatible with both active-low and active-high controllers (see Applications Information section). The switch rise times are controlled to eliminate power supply glitching.

The LTC1470 features built-in SafeSlot[™] current limit and thermal shutdown. The output is limited to 1A during short circuit to ground but 2A of peak operating current is allowed.

The LTC1471 is a dual version of the LTC1470 and is available in a 16-pin SO package.

LT, LTC and LT are registered trademarks of Linear Technology Corporation. SafeSlot is a trademark of Linear Technology Corporation. All other trademarks are the property of their respective owners.

TYPICAL APPLICATION

Dual Slot PCMCIA 3.3V/5V V_{CC} Switch

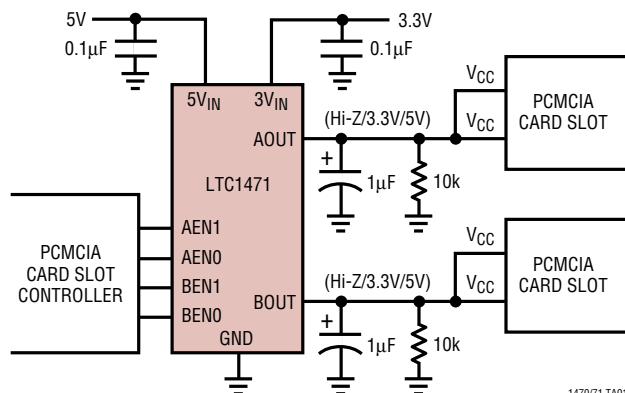

1470/71 TA01

Linear Technology PCMCIA Product Family

DEVICE	DESCRIPTION	PACKAGE
LT [®] 1312	Single PCMCIA VPP Driver/Regulator	8-Pin SO
LT1313	Dual PCMCIA VPP Driver/Regulator	16-Pin SO*
LTC1314	Single PCMCIA Switch Matrix	14-Pin SO
LTC1315	Dual PCMCIA Switch Matrix	24-Pin SSOP
LTC1470	Single Protected V_{CC} 3.3V/5V Switch Matrix	8-Pin SO
LTC1471	Dual Protected V_{CC} 3.3V/5V Switch Matrix	16-Pin SO*
LTC1472	Protected V_{CC} and VPP Switch Matrix	16-Pin SO*

*Narrow Body

LTC1470/LTC1471

ABSOLUTE MAXIMUM RATINGS (Note 1)

3.3V Supply Voltage ($3V_{IN}$) (Note 2)	7V	Operating Temperature	
5V Supply Voltage ($5V_{IN}$) (Note 2)	7V	LTC1470C	0°C to 70°C
Enable Input Voltage	$5V_{IN}$ to (GND – 0.3V)	LTC1470E (Note 7)	–40°C to 85°C
Output Voltage (OFF) (Note 2)	7V to (GND – 0.3V)	Junction Temperature	100°C
Output Short-Circuit Duration	Indefinite	Storage Temperature Range	–65°C to 150°C
		Lead Temperature (Soldering, 10 sec)	300°C

PACKAGE/ORDER INFORMATION

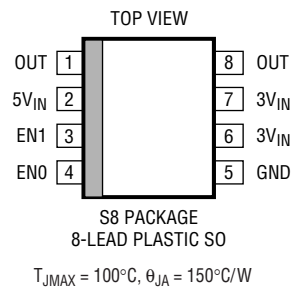
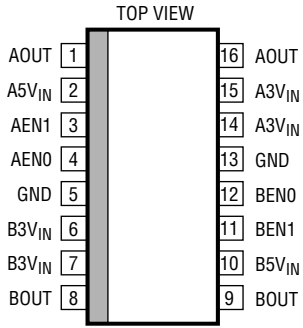
 <p>S8 PACKAGE 8-LEAD PLASTIC SO $T_{JMAX} = 100^{\circ}C, \theta_{JA} = 150^{\circ}C/W$</p>	ORDER PART NUMBER	 <p>S PACKAGE 16-LEAD PLASTIC SO $T_{JMAX} = 100^{\circ}C, \theta_{JA} = 100^{\circ}C/W$</p>	ORDER PART NUMBER
	LTC1470CS8 LTC1470ES8		LTC1471CS
	S8 PART MARKING		
	1470 1470E		

Consult LTC Marketing for parts specified with wider operating temperature ranges.

ELECTRICAL CHARACTERISTICS

The ● denotes the specifications which apply over the full operating temperature range, otherwise specifications are at $T_A = 25^{\circ}C$. $3V_{IN} = 3.3V$, $5V_{IN} = 5V$ (Note 3), unless otherwise noted.

SYMBOL	PARAMETER	CONDITIONS	MIN	TYP	MAX	UNITS
$3V_{IN}$	3.3V Supply Voltage Range		2.70		3.60	V
$5V_{IN}$	5V Supply Voltage Range		4.75		5.25	V
I_{3VIN}	3.3V Supply Current	Program to Hi-Z (Note 4) Program to 3.3V, No Load (Note 4) Program to 5V, No Load (Note 4)	●	0.01 40 0.01	10 80 10	μA μA μA
I_{5VIN}	5V Supply Current	Program to Hi-Z (Note 4) Program to 3.3V (Note 4) Program to 5V (Note 4)	●	0.01 100 140	10 160 200	μA μA μA
R_{ON}	3.3V Switch ON Resistance 5V Switch ON Resistance	Program to 3.3V, $I_{OUT} = 500mA$ Program to 5V, $I_{OUT} = 500mA$		0.12 0.14	0.16 0.18	Ω Ω
I_{LKG}	Output Leakage Current OFF	Program to Hi-Z, $0V \leq V_{OUT} \leq 5V$ (Note 4)	●		± 10	μA
I_{LIM3V}	3.3V Current Limit	Program to 3.3V, $V_{OUT} = 0V$ (Note 5)		1		A
I_{LIM5V}	5V Current Limit	Program to 5V, $V_{OUT} = 0V$ (Note 5)		1		A
V_{ENH}	Enable Input High Voltage		●	2.0		V
V_{ENL}	Enable Input Low Voltage		●		0.8	V
I_{EN}	Enable Input Current	$0V \leq V_{EN} \leq 5V$			± 1	μA

ELECTRICAL CHARACTERISTICS $3V_{IN} = 3.3V$, $5V_{IN} = 5V$ (Note 3), $T_A = 25^\circ C$, unless otherwise noted.

SYMBOL	PARAMETER	CONDITIONS	MIN	TYP	MAX	UNITS
t_0 to t_3	Delay and Rise Time (Note 6)	Transition from 0V to 3.3V, $R_{OUT} = 100\Omega$, $C_{OUT} = 1\mu F$	0.2	0.32	1.0	ms
t_3 to t_5	Delay and Rise Time (Note 6)	Transition from 3.3V to 5V, $R_{OUT} = 100\Omega$, $C_{OUT} = 1\mu F$	0.2	0.52	1.0	ms
t_0 to t_5	Delay and Rise Time (Note 6)	Transition from 0V to 5V, $R_{OUT} = 100\Omega$, $C_{OUT} = 1\mu F$	0.2	0.38	1.0	ms

Note 1: Absolute Maximum Ratings are those values beyond which the life of a device may be impaired.

Note 2: For the LTC1470, the two output pins (1, 8) must be connected together and the two 3.3V supply input pins (6, 7) must be connected together. For the LTC1471, the two AOUT pins (1, 16) must be connected together, the two BOUT pins (8, 9) must be connected together, the two A3V_{IN} supply input pins (14, 15) must be connected together, the two B3V_{IN} supply pins (6, 7) must be connected together and the two GND pins (5, 13) must be connected together.

Note 3: Power for the input logic and charge pump circuitry is derived from the 5V_{IN} supply pin(s) which must be continuously powered.

Note 4: Measured current is per channel with the other channel programmed off for the LTC1471.

Note 5: The output is protected with foldback current limit which reduces the short-circuit (0V) currents below peak permissible current levels at higher output voltages.

Note 6: To 90% of final value.

Note 7: The LTC1470 is guaranteed to meet performance specifications from 0°C to 70°C. Specifications over the -40°C to 85°C operating temperature range are assured by design, characterization and correlation with statistical process controls.

TYPICAL PERFORMANCE CHARACTERISTICS (LTC1470 or 1/2 LTC1471)

3V_{IN} Supply Current (OFF)

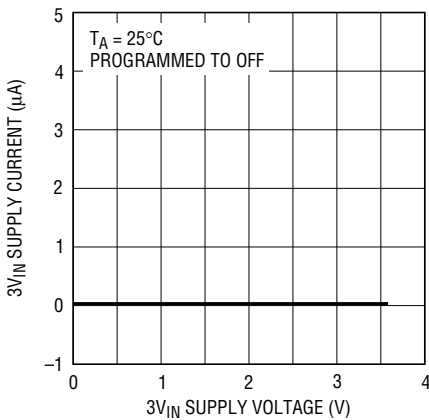

1470/71 G04

3V_{IN} Supply Current (3.3V ON)

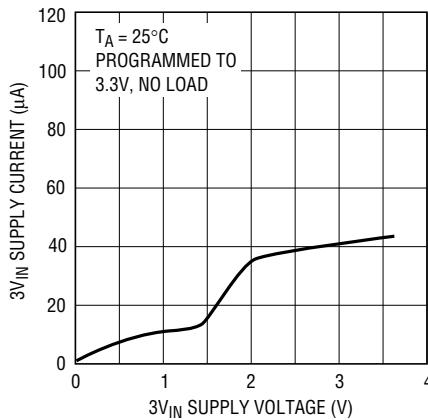

1470/71 G05

5V_{IN} Supply Current (OFF)

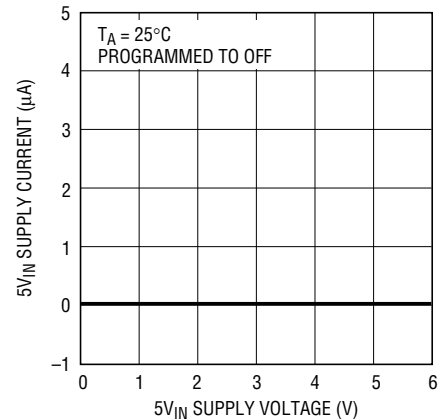

1470/71 G01

5V_{IN} Supply Current (3.3V ON)

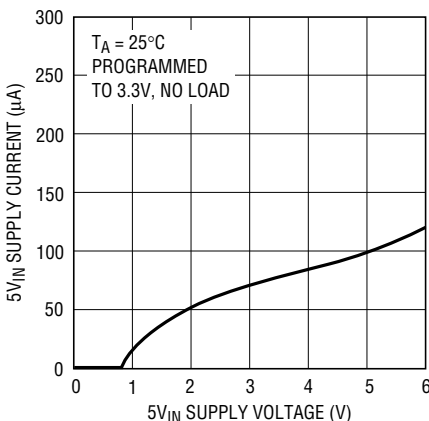

1470/71 G03

5V_{IN} Supply Current (5V ON)

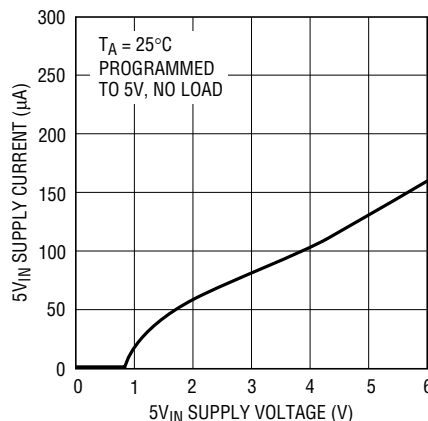

1470/71 G02

3.3V Switch Resistance

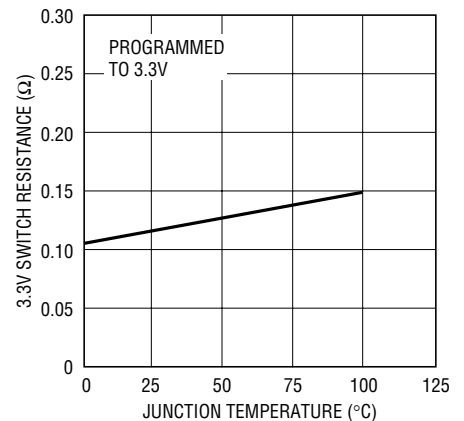

1470/71 G07

14701fa

TYPICAL PERFORMANCE CHARACTERISTICS (LTC1470 or 1/2 LTC1471)

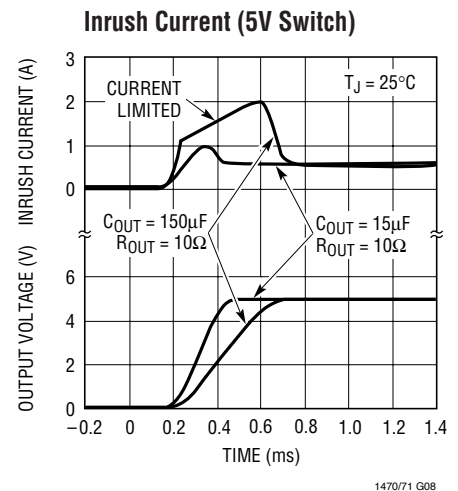
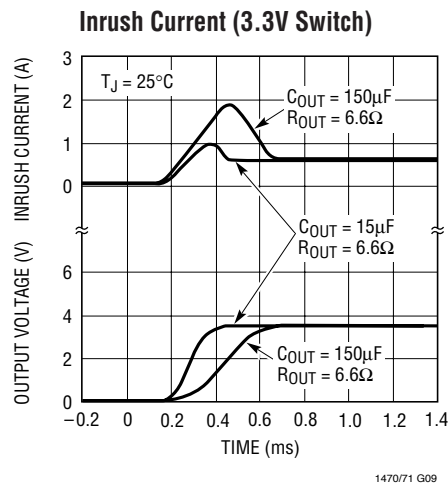
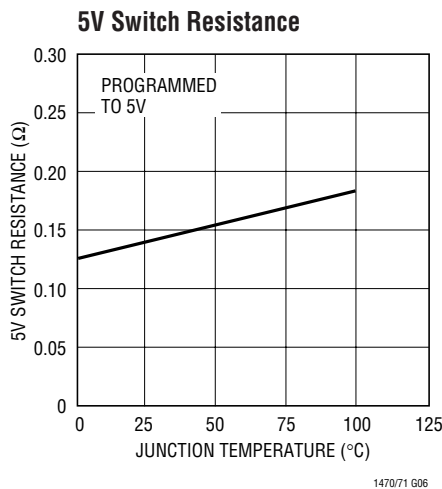

PIN FUNCTIONS

LTC1470

OUT (Pins 1, 8): Output Pins. The outputs of the LTC1470 are switched between three operating states: OFF, 3.3V and 5V. These pins are protected against accidental short circuits to ground by SafeSlot current limit circuitry which protects the socket, the card, and the system power supplies against damage. A second level of protection is provided by thermal shutdown circuitry which protects both switches against over-temperature conditions.

5V_{IN} (Pin 2): 5V Input Supply Pin. The 5V_{IN} supply pin serves two purposes. The first purpose is as the power supply input for the 5V NMOS switch. The second purpose is to provide power for the input, gate drive, and protection circuitry for both the 3.3V and 5V V_{CC} switches. This pin must therefore be continuously powered.

EN1, EN0 (Pins 3, 4): Enable Inputs. The two V_{CC} Enable inputs are designed to interface directly with industry standard PCMCIA controllers and are high impedance CMOS gates with ESD protection diodes to ground, and

should not be forced above 5V_{IN} or below ground. Both inputs have about 100mV of built-in hysteresis to ensure clean switching between operating modes. The LTC1470 is designed to operate *without* 12V power. The gates of the V_{CC} NMOS switches are powered by charge pumps from the 5V_{IN} supply pins (see Applications Information section for more detail). The Enable inputs should be turned off (both asserted high or both asserted low) at least 100µs before the 5V_{IN} power is removed to ensure that both V_{CC} NMOS switch gates are fully discharged and both switches are in the high impedance mode.

GND (Pin 5): Ground Connection.

3V_{IN} (Pins 6, 7): 3V Input Supply Pins. The 3V_{IN} supply pins serve as the power supply input for the 3.3V switches. These pins do not provide any power to the internal control circuitry and therefore do not consume any power when unloaded or turned off.

PIN FUNCTIONS

LTC1471

AOUT, BOUT (Pins 1, 16, 8, 9): Output Pins. The outputs of the LTC1471 are switched between three operating states: OFF, 3.3V and 5V. These pins are protected against accidental short circuits to ground by SafeSlot current limit circuitry which protects the socket, the card, and the system power supplies against damage. A second level of protection is provided by thermal shutdown circuitry.

5V_{IN} (Pins 2, 10): 5V Input Supply Pins. The 5V_{IN} supply pins serve two purposes. The first purpose is as the power supply input for the 5V NMOS switches. The second purpose is to provide power for the input, gate drive, and protection circuitry. These pins must therefore be continuously powered.

EN1, EN0 (Pins 3, 4, 11, 12): Enable Inputs. The enable inputs are designed to interface directly with industry standard PCMCIA controllers and are high impedance CMOS gates with ESD protection diodes to ground, and

should not be forced above 5V_{IN} or below ground. All four inputs have about 100mV of built-in hysteresis to ensure clean switching between operating modes. The LTC1471 is designed to operate *without* 12V power. The gates of the V_{CC} NMOS switches are powered by charge pumps from the 5V_{IN} supply pins (see Applications Information section for more detail). The enable inputs should be turned off at least 100μs before the 5V_{IN} power is removed to ensure that all NMOS switch gates are fully discharged and are in the high impedance mode.

GND (Pins 5, 13): Ground Connections.

3V_{IN} (Pins 6, 7, 14, 15): 3V Input Supply Pins. The 3V_{IN} supply pins serve as the power supply input for the 3.3V switches. These pins do not provide any power to the internal control circuitry, and therefore, do not consume any power when unloaded or turned off.

BLOCK DIAGRAM (LTC1470 or 1/2 LTC1471)

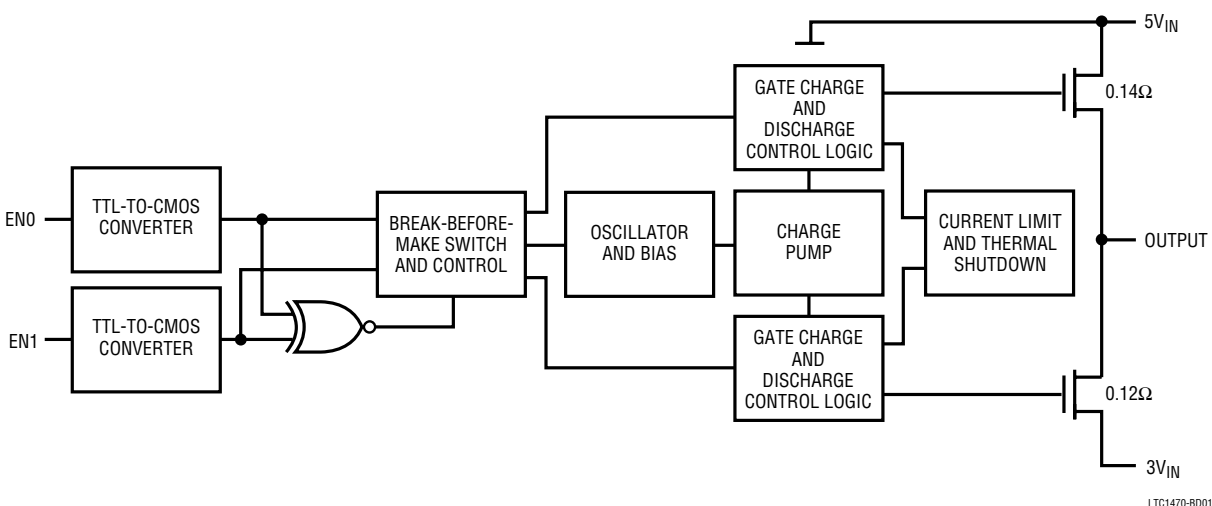

OPERATION

The LTC1470 (or 1/2 of the LTC1471) consists of the following functional blocks:

Input TTL/CMOS Converters

The enable inputs are designed to accommodate a wide range of 3V and 5V logic families. The input threshold voltage is approximately 1.4V with approximately 100mV of hysteresis. The inputs enable the bias generator, the gate charge pumps and the protection circuitry which are powered from the 5V supply. Therefore, when the inputs are turned off, the entire circuit is powered down and the 5V supply current drops below 1 μ A.

XOR Input Circuitry

By employing an XOR function, which locks out the 3.3V switch when the 5V switch is turned on and locks out the 5V switch when the 3.3V switch is turned on, there is no danger of both switches being on at the same time. This XOR function also makes it possible to work with either active-low or active-high PCMCIA V_{CC} switch control logic (see Applications Information section for further details).

Break-Before-Make Switch Control

Built-in delays are provided to ensure that the 3.3V and 5V switches are non-overlapping. Further, the gate charge pump includes circuitry which ramps the NMOS switches

on slowly (400 μ s typical rise time) but turns them off much more quickly (typically 10 μ s).

Bias, Oscillator and Gate Charge Pump

When either the 3.3V or 5V switch is enabled, a bias current generator and high frequency oscillator are turned on. The on-chip capacitive charge pump generates approximately 12V of gate drive for the internal low $R_{DS(ON)}$ NMOS V_{CC} switches from the 5V_{IN} power supply. Therefore, an external 12V supply is not required to switch the V_{CC} output. The 5V_{IN} supply current drops below 1 μ A when both switches are turned off.

Gate Charge and Discharge Control

All switches are designed to ramp on slowly (400 μ s typical rise time). Turn-off time is much quicker (typically 10 μ s). To ensure that both V_{CC} NMOS switch gates are fully discharged, program the switch to the high impedance mode at least 100 μ s before turning off the 5V power supply.

Switch Protection

Both switches are protected against accidental short circuits with SafeSlot foldback current limit circuits which limit the output current to typically 1A when the output is shorted to ground. Both switches also have thermal shut-down which limits the power dissipation to safe levels.

APPLICATIONS INFORMATION

The LTC1470/LTC1471 are designed to interface directly with industry standard PCMCIA card controllers.

Interfacing with the CL-PD6710

Figure 1 is a schematic diagram showing the LTC1470 interfaced with a standard PCMCIA slot controller. The LTC1470 accepts logic control directly from the CL-PD6710.

The XOR input function allows the LTC1470 to interface directly to the active-low V_{CC} control outputs of the CL-PD6710 for 3.3V/5V voltage selection (see the following Switch Truth Table). Therefore, no "glue" logic is required to interface to this PCMCIA compatible card controller.

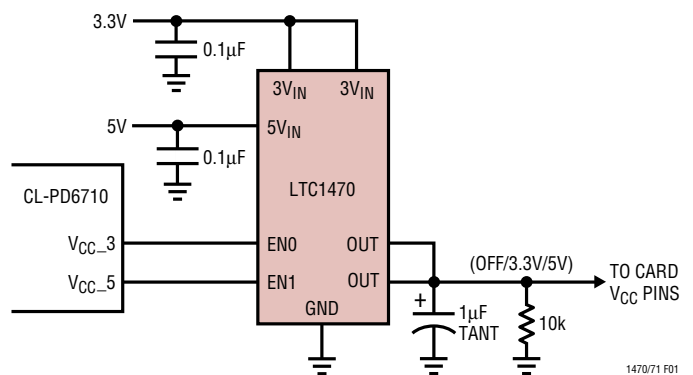

Figure 1. Direct Interface to CL-PD6710 PCMCIA Controller

APPLICATIONS INFORMATION

Truth Table for CL-PD6710 Controller

A_V _{CC_3}	A_V _{CC_5}	OUT
ENO	EN1	
0	0	Hi-Z
0	1	3.3V
1	0	5V
1	1	Hi-Z

Interfacing with “365” Type Controllers

The LTC1470 also interfaces directly with “365” type controllers as shown in Figure 2. Note that the V_{CC} Enable inputs are connected differently than to the CL-PD6710 controller because the “365” type controllers use active-high logic control of the V_{CC} switches (see the following Switch Truth Table). No “glue” logic is required to interface to this type of PCMCIA compatible controller.

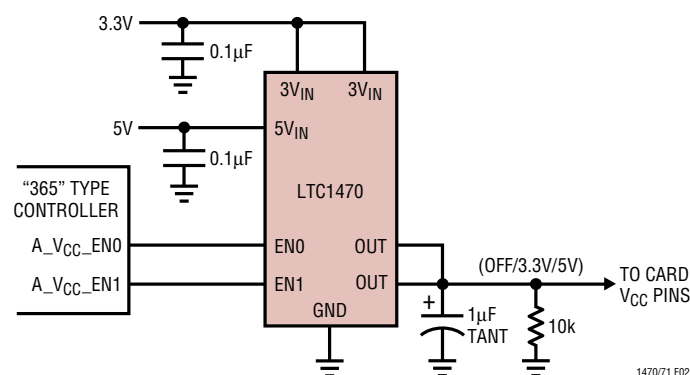

Figure 2. Direct Interface with “365” Type PCMCIA Controller

Truth Table for “365” Type Controller

A_V _{CC_EN0}	A_V _{CC_EN1}	OUT
ENO	EN1	
0	0	Hi-Z
0	1	3.3V
1	0	5V
1	1	Hi-Z

Supply Bypassing

For best results bypass the supply input pins with 1µF capacitors as close as possible to the LTC1470. Sometimes much larger capacitors are already available at the outputs of the 3.3V and 5V power supply. In this case it is still good practice to use 0.1µF capacitors as close as possible to the device, especially if the power supply output capacitors are more than 2" away on the printed circuit board.

Output Capacitors and Pull-Down Resistor

The output pin is designed to ramp on slowly, typically 400µs rise time. Therefore, capacitors as large as 150µF can be driven without producing voltage spikes on the 3V_{IN} or 5V_{IN} supply pins (see graphs in Typical Performance Characteristics section). The output pin should have a 0.1µF to 1µF capacitor for noise reduction and smoothing.

A 10k pull-down resistor is recommended at the output to ensure that the output capacitor is fully discharged when the output is switched OFF. This resistor also ensures that the output is discharged between the 3.3V and 5V transition.

Supply Sequencing

Because the 5V supply is the source of power for both of the switch control circuits, it is best to sequence the power supplies such that the 5V supply is powered before, or simultaneous to, the application of 3.3V.

It is interesting to note, however, that the switches are NMOS transistors which require charge pumps to generate gate voltages higher than the supply rails for full enhancement. Because the gate voltages start at 0V when the supplies are first activated, the switches always start in the off state and do not produce glitches at the outputs when powered.

If the 5V supply must be turned off, it is important to program all switches to the Hi-Z or 0V state at least 100µs before the 5V power is removed to ensure that the NMOS switch gates are fully discharged to 0V. Whenever possible, however, it is best to leave the 5V_{IN} pin(s) continuously powered. The LTC1470/LTC1471 quiescent current drops to <1µA with all the switches turned off and therefore no 5V power is consumed in the standby mode.

APPLICATIONS INFORMATION

TOTAL SYSTEM COST CONSIDERATIONS

The cost of an additional step-up switching regulator, inductor, rectifier and capacitors to produce 12V for VPP can be eliminated by using an auxiliary winding on either the 3.3V or 5V output of the system switching regulator to produce an auxiliary 15V supply for VPP power.

And, because the LTC1470/LTC1471 do not require 12V power to operate (only 5V), the 12V VPP regulation and switching may be operated separately from the 3.3V/5V V_{CC} switching. This increases system configuration flexibility and *reduces total system cost* by eliminating the need for a third regulator for 12V power.

LTC1142HV Auxiliary Winding Power Supply

Figure 3 is a schematic diagram which describes how a loosely regulated 15V power supply is created by adding an auxiliary winding to the 5V inductor in a split 3.3V/5V LTC1142HV power supply system. An LT1313, dual VPP regulator/driver with SafeSlot protection, produces “clean” 3.3V, 5V and 12V power from this loosely regulated 15V output for the PC card slot VPP pins. (See LT1312 and LT1313 data sheets for further detail.)

A turns ratio of 1:1.8 is used for transformer T1 to ensure that the input voltage to the LT1313 falls between 13V and 20V under all load conditions. The 9V output from this additional

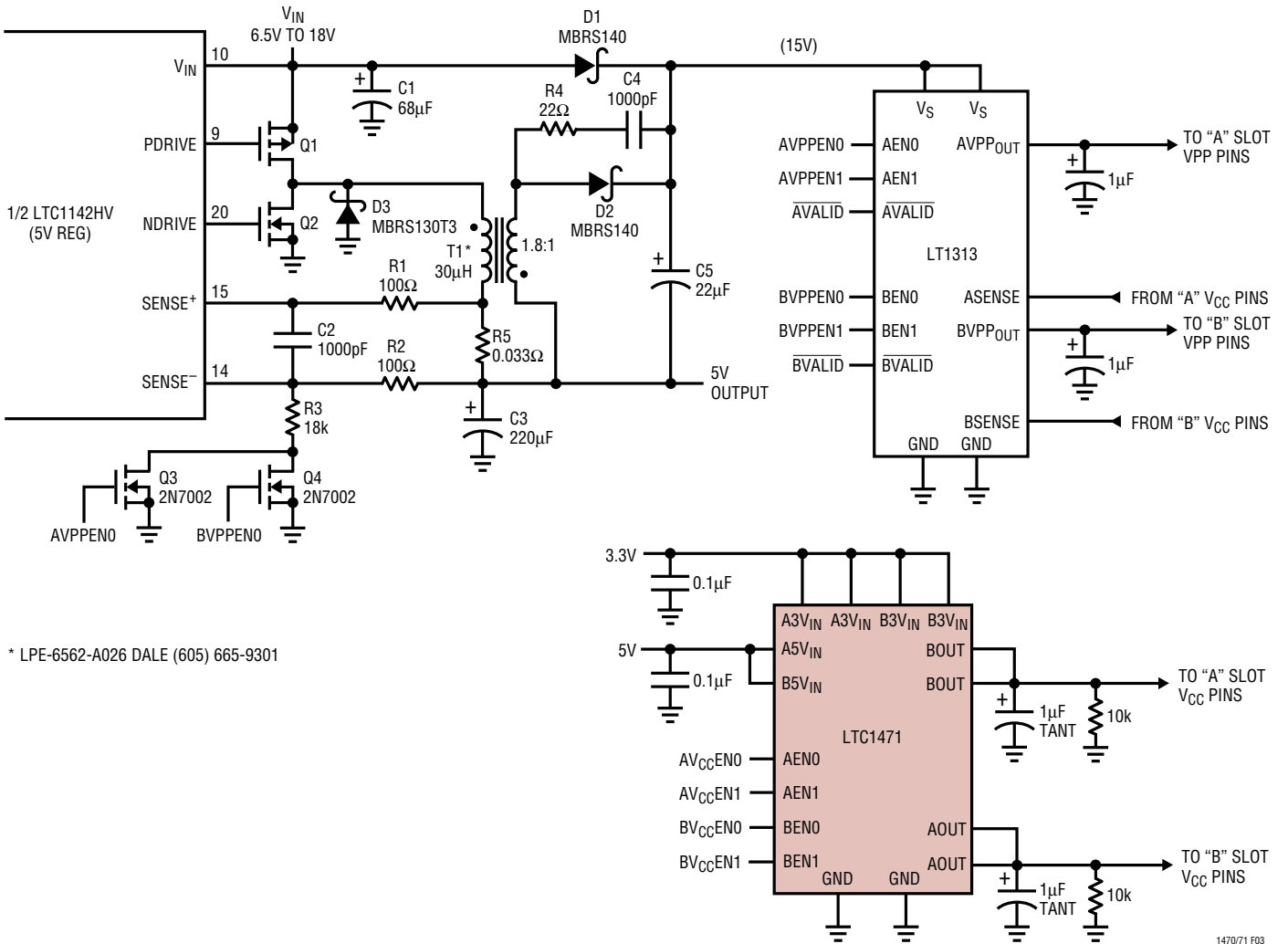

* LPE-6562-A026 DALE (605) 665-9301

Figure 3. Cost Effective Complete SafeSlot Dual PCMCIA Power Management System (with 15V Auxiliary Supply from LTC1142HV 5V Regulator Inductor)

1470/71 F03

APPLICATIONS INFORMATION

winding is rectified by diode D2, added to the main 5V output and applied to the input of the LT1313. (Note that the auxiliary winding must be phased properly as shown in Figure 3.)

When the 12V output is activated by a TTL high on either VPP enable lines, the 5V section of the LTC1142HV is forced into continuous mode operation. A resistor divider composed of R2, R3 and switch Q3 forces an offset which is subtracted from the internal offset at the Sense⁻ input (pin 14) of the LTC1142HV. When this external offset cancels the built-in 25mV offset, Burst Mode™ operation is inhibited and the LTC1142HV is forced into continuous mode operation. (See LTC1142HV data sheet for further detail.) In this mode, the 15V auxiliary supply can be loaded without regard to the loading on the 5V output of the LTC1142HV.

Continuous mode operation is only invoked when the LT1313 is programmed to 12V. If the LT1313 is programmed to 0V, 3.3V or 5V, power is obtained directly from the main power source (battery pack) through diode D1. Again, the LT1313 output can be loaded without regard to the loading of the main 5V output.

R4 and C4 absorb transient voltage spikes associated with the leakage inductance inherent in T1's secondary winding and ensure that the auxiliary supply does not exceed 20V.

Auxiliary Power from the LTC1142 3.3V Output

For low-battery count applications (<6.5V) it is necessary to modify the circuit of Figure 3. As the input voltage falls, the 5V duty cycle increases to the point where there is simply not enough time to transfer energy from the 5V primary winding to the auxiliary winding. For applications where 12V load currents exist in conjunction with these low input voltages, use the circuit shown in Figure 4. In this circuit, the auxiliary 15V supply is generated from an overwinding on the 3.3V inductor of the LTC1142 regulator output.

In Figure 3, power is drawn directly from the batteries through D1 when the regulator is in Burst Mode operation and the VPP pins require 3.3V or 5V. In this circuit, however, Q3 and Q4 force the LTC1142 3.3V regulator into continuous mode operation whenever 3.3V, 5V or 12V is programmed at the VPP_{OUT} pins of the LT1313. (See the LT1312 and LT1313 data sheets for further detail.)

Burst Mode is a trademark of Linear Technology Corporation.

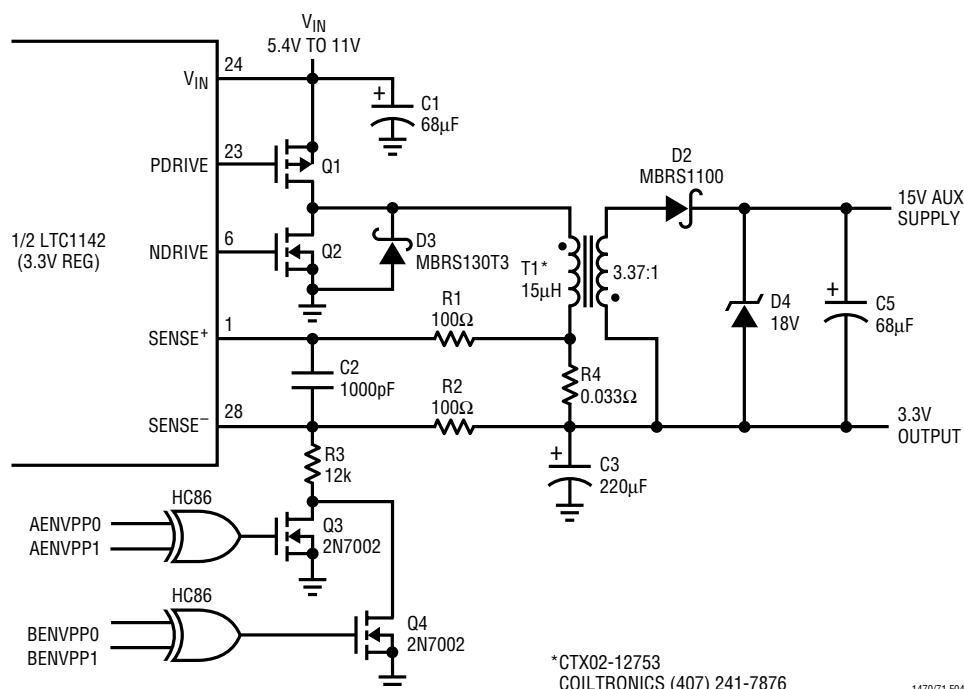
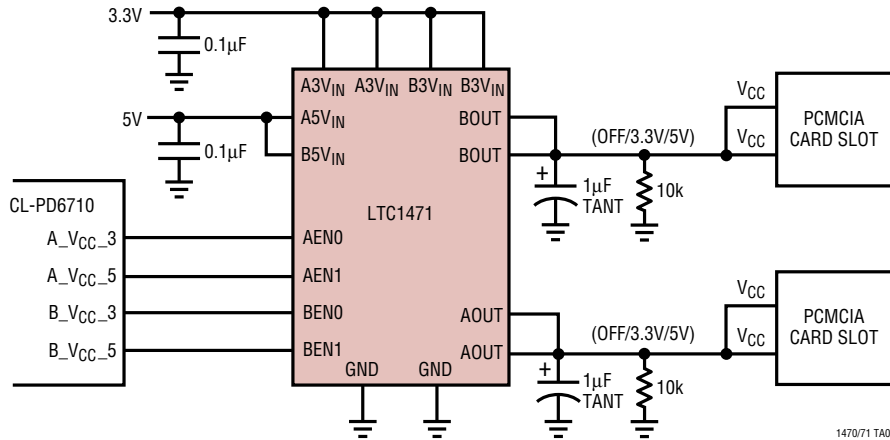

Figure 4. Deriving 15V from the 3.3V Output of the LTC1142 for VPP Power

TYPICAL APPLICATIONS

Dual Slot 3.3V/5V PCMCIA Controller with SafeSlot Current Limit
(Systems with No 12V Power Requirements)



1470/71 TA02

Single Slot PCMCIA Controller with SafeSlot Current Limit
Protection Using LT1312 Single VPP Regulator/Driver

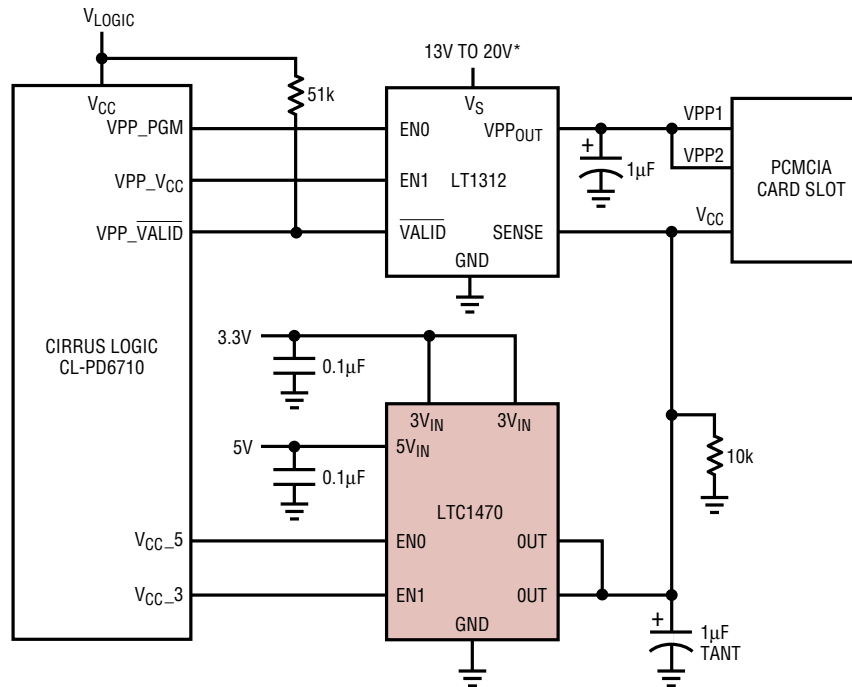

* FROM OVERWINDING ON 3.3V OR 5V INDUCTOR IN SYSTEM POWER SUPPLY.
SEE FIGURES 3, 4 FOR FURTHER DETAIL

1470/71 TA03

PACKAGE DESCRIPTION

S8 Package 8-Lead Plastic Small Outline (Narrow .150 Inch) (Reference LTC DWG # 05-08-1610)

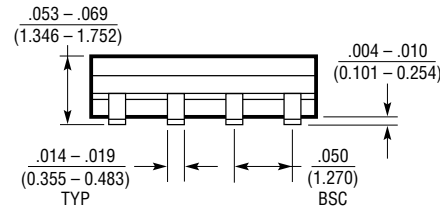
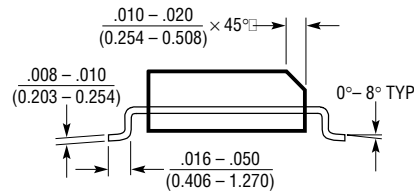
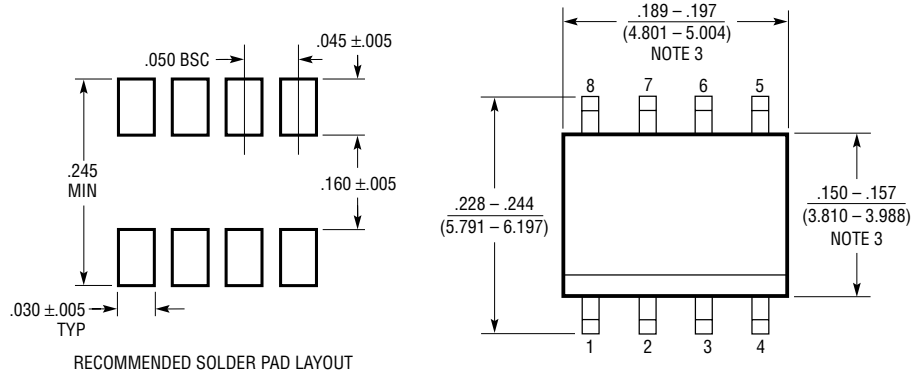

NOTE:
1. DIMENSIONS IN $\frac{\text{INCHES}}{\text{MILLIMETERS}}$
2. DRAWING NOT TO SCALE
3. THESE DIMENSIONS DO NOT INCLUDE MOLD FLASH OR PROTRUSIONS.
MOLD FLASH OR PROTRUSIONS SHALL NOT EXCEED .006" (0.15mm)

S08 0303

S Package 16-Lead Plastic Small Outline (Narrow .150 Inch) (Reference LTC DWG # 05-08-1610)

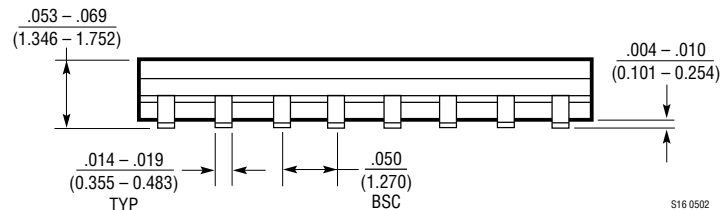
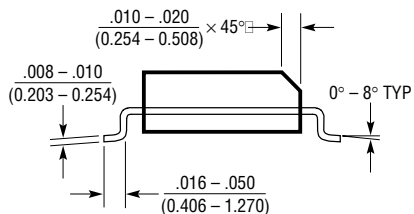
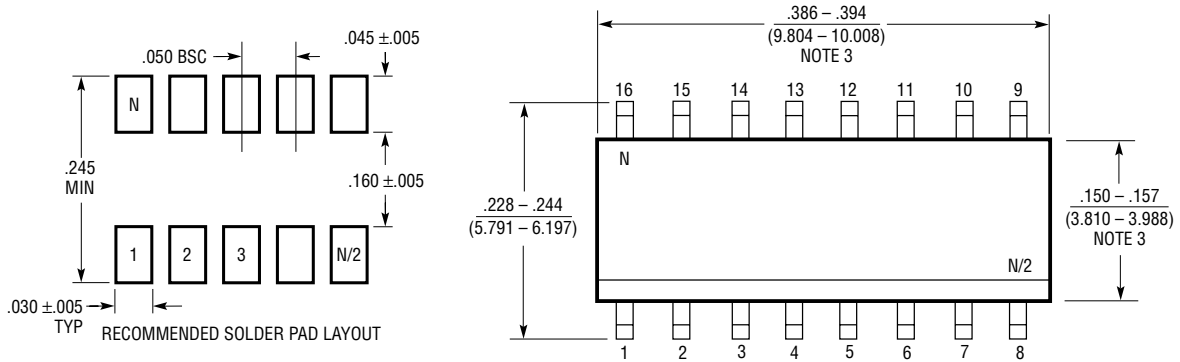

NOTE:
1. DIMENSIONS IN $\frac{\text{INCHES}}{\text{MILLIMETERS}}$
2. DRAWING NOT TO SCALE
3. THESE DIMENSIONS DO NOT INCLUDE MOLD FLASH OR PROTRUSIONS.
MOLD FLASH OR PROTRUSIONS SHALL NOT EXCEED .006" (0.15mm)

S16 0502

TYPICAL APPLICATIONS

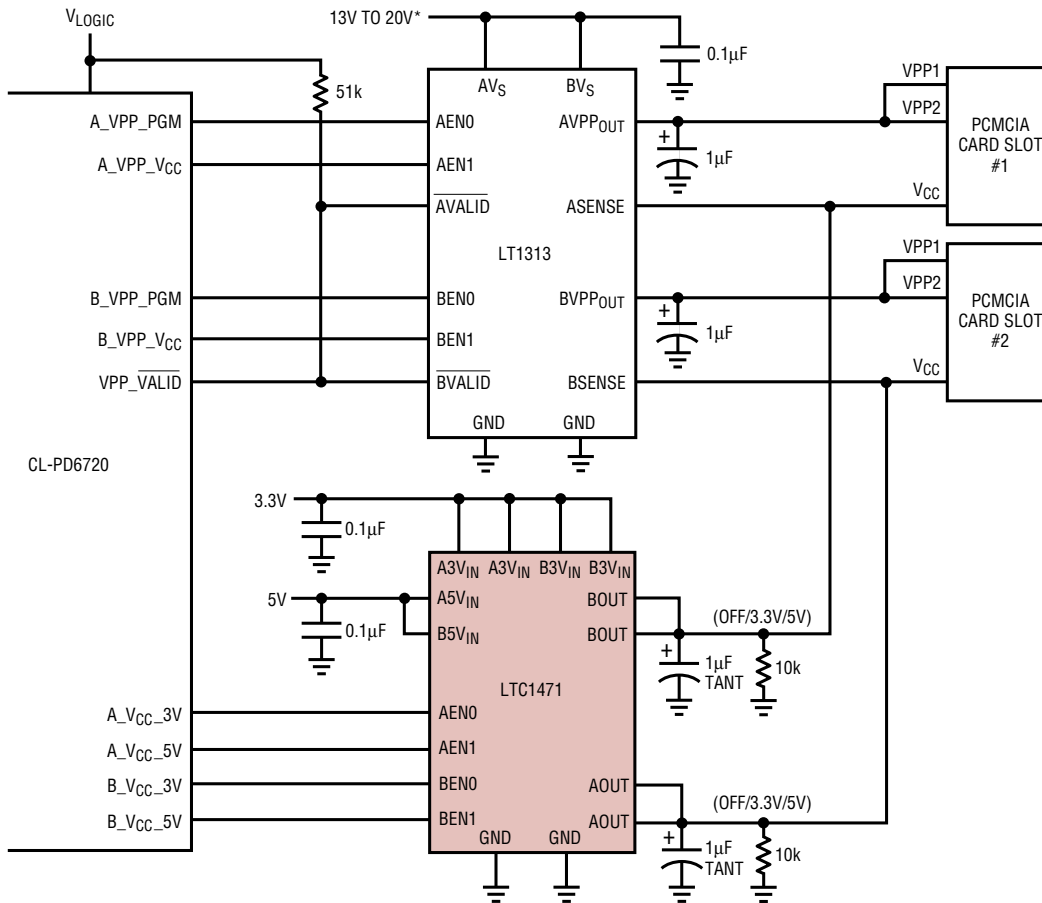

* FROM OVERWINDING ON 3.3V OR 5V INDUCTOR IN SYSTEM POWER SUPPLY. SEE FIGURES 3, 4 FOR FURTHER DETAILS

1470/71 TA04



RELATED PARTS

PART NUMBER	DESCRIPTION	COMMENTS
LTC3405/LTC3405A LTC3405A-1.5 LTC3405A-1.8	300mA (I _{OUT}), 1.5MHz, Synchronous Step-Down DC/DC Converters	95% Efficiency, V _{IN} = 2.7V to 6V, V _{OUT} = 0.8V, I _Q = 20µA I _{SD} < 1µA, ThinSOT Package
LTC3406/LTC3406B	600mA (I _{OUT}) 1.5MHz, Synchronous Step-Down DC/DC Converter	95% Efficiency, V _{IN} = 2.5V to 5.5V, V _{OUT} = 0.6V, I _Q = 20µA I _{SD} < 1µA, ThinSOT Package
LTC3411	1.25A (I _{OUT}), 4MHz, Synchronous Step-Down DC/DC Converter	95% Efficiency, V _{IN} = 2.5V to 5.5V, V _{OUT} = 0.8V, I _Q = 60µA I _{SD} < 1µA, MS10 Package
LTC3412	2.5A (I _{OUT}), 4MHz, Synchronous Step-Down DC/DC Converter	95% Efficiency, V _{IN} = 2.5V to 5.5V, V _{OUT} = 0.8V, I _Q = 60µA I _{SD} < 1µA, TSSOP16E Package
LTC3413	3A (I _{OUT}), Sink/Source, 2MHz, Monolithic Synchronous Regulator for DDR/QDR Memory Termination	90% Efficiency, V _{IN} = 2.25V to 5.5V, V _{OUT} = V _{REF} /2, I _Q = 280µA I _{SD} < 1µA, TSSOP16E Package
LT3430	60V, 2.75A (I _{OUT}), 200kHz, High Efficiency Step-Down DC/DC Converter	90% Efficiency, V _{IN} = 5.5V to 60V, V _{OUT} = 1.20V, I _Q = 2.5mA I _{SD} = 25µA, TSSOP16E Package
LTC3440	600mA (I _{OUT}), 2MHz, Synchronous Buck-Boost DC/DC Converter	95% Efficiency, V _{IN} = 2.5V to 5.5V, V _{OUT} = 2.5V, I _Q = 25µA I _{SD} < 1µA, MS Package

14701fa

Looking for pricing, stock, or lifecycle information?

Click below to explore more details on WIN SOURCE:

-  [View LTC1470ES8#TRPBF on WIN SOURCE](#)
-  [Analog Devices Inc. Information](#)

Optimize Your Supply Chain with WIN SOURCE Solutions

-  Global Sourcing Solution
-  Obsolete Management
-  Cost Control Management
-  Shortage Management
-  Alternative Solution
-  Excess Inventory Management