

LTC7060

ABSOLUTE MAXIMUM RATINGS

(Note 1)

V_{CC} Supply Voltage	-0.3V to 15V
Top Side Driver Voltage (BST)	-0.3V to 115V
Bottom Side Driver Voltage (BGV_{CC})	-0.3V to 115V
SW, BGRTN	-10V to 100V
(BST-SW)	-0.3V to 15V
(BGV_{CC} -BGRTN)	-0.3V to 15V
EN, \overline{FLT}	-0.3V to 15V
DT, PWM	-0.3V to 6V
Driver Output TG (with Respect to SW)	-0.3V to 15V
Driver Output BG (with Respect to BGRTN)	-0.3V to 15V
Operating Junction Temperature Range (Note 2, 3)	-40°C to 150°C
Storage Temperature Range	-65°C to 150°C

Note: All voltages are referred to SGND unless otherwise noted.

PIN CONFIGURATION

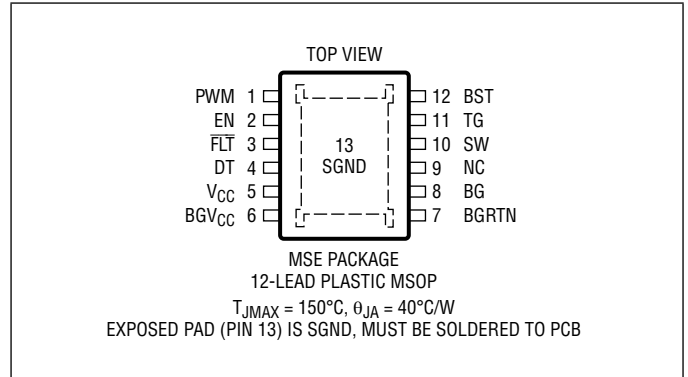

ORDER INFORMATION

LEAD FREE FINISH	TAPE AND REEL	PART MARKING*	PACKAGE DESCRIPTION	TEMPERATURE RANGE
LTC7060EMSE#PBF	LTC7060EMSE#TRPBF	LTC7060	12-Lead Plastic MSSOP	-40°C to 125°C
LTC7060IMSE#PBF	LTC7060IMSE#TRPBF	LTC7060	12-Lead Plastic MSSOP	-40°C to 125°C
LTC7060JMSE#PBF	LTC7060JMSE#TRPBF	LTC7060	12-Lead Plastic MSSOP	-40°C to 150°C
LTC7060HMSE#PBF	LTC7060HMSE#TRPBF	LTC7060	12-Lead Plastic MSSOP	-40°C to 150°C
AUTOMOTIVE PRODUCTS**				
LTC7060EMSE#WPBF	LTC7060EMSE#WTRPBF	LTC7060	12-Lead Plastic MSSOP	-40°C to 125°C
LTC7060IMSE#WPBF	LTC7060IMSE#WTRPBF	LTC7060	12-Lead Plastic MSSOP	-40°C to 125°C
LTC7060JMSE#WPBF	LTC7060JMSE#WTRPBF	LTC7060	12-Lead Plastic MSSOP	-40°C to 150°C
LTC7060HMSE#WPBF	LTC7060HMSE#WTRPBF	LTC7060	12-Lead Plastic MSSOP	-40°C to 150°C

Contact the factory for parts specified with wider operating temperature ranges. *The temperature grade is identified by a label on the shipping container.

Tape and reel specifications. Some packages are available in 500 unit reels through designated sales channels with #TRMPBF suffix.

**Versions of this part are available with controlled manufacturing to support the quality and reliability requirements of automotive applications. These models are designated with a #W suffix. Only the automotive grade products shown are available for use in automotive applications. Contact your local Analog Devices account representative for specific product ordering information and to obtain the specific Automotive Reliability reports for these models.

ELECTRICAL CHARACTERISTICS The ● denotes the specifications which apply over the specified operating temperature range, otherwise specifications are at $T_A = 25^\circ\text{C}$ (Note 2). $V_{CC} = V_{BGVCC} = V_{BST} = 10\text{V}$, $V_{BGRTN} = V_{SW} = 0\text{V}$, unless otherwise noted.

SYMBOL	PARAMETER	CONDITIONS	MIN	TYP	MAX	UNITS	
Input Supply and V_{CC} Supply							
V_{IN}	Input Supply Operating Range				100	V	
V_{CC}	IC Supply Operating Range		6		14	V	
I_{VCC}	V_{CC} Supply Current	$V_{EN} = V_{PWM} = 0\text{V}$, $R_{DT} = 100\text{k}\Omega$		0.4		mA	
V_{UVLO_VCC}	V_{CC} Undervoltage Lockout Threshold	V_{CC} Falling	5	5.3	5.6	V	
		Hysteresis		0.3		V	
V_{OVLO_VCC}	V_{CC} OVLO Threshold	V_{CC} Rising		14.6		V	
		Hysteresis		0.8		V	
BG Gate Driver Supply (BGV_{CC}-BGRTN)							
$V_{BGVCC\text{-}BGRTN}$	BG Driver Supply Voltage Range (With Respect to BGRTN)		4		14	V	
I_{BGVCC}	Total BGV_{CC} Current (Note 4)	BG = Low		8		μA	
		BG = High		100		μA	
V_{UVLO_BGVCC}	Undervoltage Lockout Threshold	BGV_{CC} Falling, With Respect to BGRTN		3.4		V	
		Hysteresis		0.3		V	
TG Gate Driver Supply (BST-SW)							
$V_{BST\text{-}SW}$	TG Driver Supply Voltage Range (With Respect to SW)		4		14	V	
I_{BST}	Total BST Current (Note 4)	TG = Low		8		μA	
		TG = High		100		μA	
V_{UVLO_BST}	Undervoltage Lockout Threshold	BST Falling, With Respect to SW		3.4		V	
		Hysteresis		0.3		V	
Input Signal (PWM, EN)							
$V_{IH(TG)}$	TG Turn-On Input Threshold	PWM Rising	●	2.6	3.1	3.6	V
$V_{IL(TG)}$	TG Turn-Off Input Threshold	PWM Falling	●	2.45	2.95	3.45	V
$V_{IH(BG)}$	BG Turn-On Input Threshold	PWM Falling	●	0.5	1	1.5	V
$V_{IL(BG)}$	BG Turn-Off Input Threshold	PWM Rising	●	0.75	1.25	1.75	V
V_{PWM_TRI}	PWM Input Three-State Float Voltage			1.9	2.1	2.3	V
R_{UP_PWM}	PWM Internal Pull-Up Resistor	To Internal 4.5V Supply		48		$\text{k}\Omega$	
R_{DOWN_PWM}	PWM Internal Pull-Down Resistor			42		$\text{k}\Omega$	
V_{ENR}	EN Pin Rising Threshold	EN Rising	●	1.1	1.2	1.3	V
V_{ENF}	EN Pin Falling Threshold	EN Falling		1.1		V	
R_{EN}	EN Pin Internal Pull-Down Resistor			2		$\text{M}\Omega$	
Dead-Time and FAULT (DT, FLT)							
$t_{PLH(BG)} / t_{PLH(TG)}$	BG/TG Low to TG/BG High Propagation Delay (Dead-Time)	$R_{DT} = 0\Omega$		32		ns	
		$R_{DT} = 24.9\text{k}\Omega$		43		ns	
		$R_{DT} = 64.9\text{k}\Omega$		62		ns	
		$R_{DT} = 100\text{k}\Omega$		76		ns	
		$R_{DT} = \text{Open}$		250		ns	
R_{FLTb}	Open Drain Pull-Down Resistance			60		Ω	
t_{FLTb}	FLT Pin Release Delay	Low to High		100		μs	

ELECTRICAL CHARACTERISTICS The ● denotes the specifications which apply over the specified operating temperature range, otherwise specifications are at $T_A = 25^\circ\text{C}$ (Note 2). $V_{CC} = V_{BGVCC} = V_{BST} = 10\text{V}$, $V_{BGRTN} = V_{SW} = 0\text{V}$, unless otherwise noted.

SYMBOL	PARAMETER	CONDITIONS	MIN	TYP	MAX	UNITS
Low Side Gate Driver Output (BG)						
$V_{OH(BG)}$	BG High Output Voltage	$I_{BG} = -100\text{mA}$, $V_{OH(BG)} = V_{BGVCC} - V_{BG}$		150		mV
$V_{OL(BG)}$	BG Low Output Voltage	$I_{BG} = 100\text{mA}$, $V_{OL(BG)} = V_{BG} - V_{BGRTN}$		80		mV
$R_{UP(BG)}$	BG Pull-Up Resistance	$V_{BGVCC-BGRTN} = 10\text{V}$		1.5		Ω
$R_{DOWN(BG)}$	BG Pull-Down Resistance	$V_{BGVCC-BGRTN} = 10\text{V}$		0.8		Ω
High Side Gate Driver Output (TG)						
$V_{OH(TG)}$	TG High Output Voltage	$I_{TG} = -100\text{mA}$, $V_{OH(TG)} = V_{BST} - V_{TG}$		150		mV
$V_{OL(TG)}$	TG Low Output Voltage	$I_{TG} = 100\text{mA}$, $V_{OL(TG)} = V_{TG} - V_{SW}$		80		mV
$R_{UP(TG)}$	TG Pull-Up Resistance	$V_{BST-SW} = 10\text{V}$		1.5		Ω
$R_{DOWN(TG)}$	TG Pull-Down Resistance	$V_{BST-SW} = 10\text{V}$		0.8		Ω
Switching Time						
$t_{PHL(BG)}$	PWM High to BG Low Propagation Delay			17		ns
$t_{PHL(TG)}$	PWM Low to TG Low Propagation Delay			17		ns
$t_r(BG)$	BG Output Rise Time	$C_{LOAD} = 3.3\text{nF}$ (Note 5)		18		ns
$t_f(BG)$	BG Output Fall Time	$C_{LOAD} = 3.3\text{nF}$ (Note 5)		13		ns
$t_r(TG)$	TG Output Rise Time	$C_{LOAD} = 3.3\text{nF}$ (Note 5)		18		ns
$t_f(TG)$	TG Output Fall Time	$C_{LOAD} = 3.3\text{nF}$ (Note 5)		13		ns
$t_{PH(EN)}$	EN High to TG/BG High Propagation Delay			30		ns
$t_{PL(EN)}$	EN Low to TG/BG Low Propagation Delay			36		ns

Note 1: Stresses beyond those listed under Absolute Maximum Ratings may cause permanent damage to the device. Exposure to any Absolute Maximum Ratings for extended periods may affect device reliability and lifetime.

Note 2: The LTC7060E is guaranteed to meet performance specifications from 0°C to 85°C junction temperature. Specifications over the -40°C to 125°C operating junction temperature range are assured by design, characterization and correlation with statistical process controls. The LTC7060I is guaranteed over the -40°C to 125°C operation junction temperature range. The LTC7060J is guaranteed over the -40°C to 150°C operation junction temperature range. The LTC7060H is guaranteed over the -40°C to 150°C operation junction temperature range. High junction temperature degrades operation lifetimes; operating lifetime is derated

for junction temperatures greater than 125°C . Note that the maximum ambient temperature consistent with these specifications is determined by specific operating conditions in conjunction with board layout, the rated package thermal impedance and other environment factors.

Note 3: T_J is calculated from the ambient temperature T_A and power dissipation PD according to the following formula

$T_J = T_A + (P_D \cdot 51^\circ\text{C/W})$ for LFCSP package; $T_J = T_A + (P_D \cdot 40^\circ\text{C/W})$ for MSOP package.

Note 4: The total current includes both the current from BGV_{CC}/BST to $BGRTN/SW$ and the current to $SGND$. Dynamic supply current is higher due to the gate charge being delivered at the switching frequency.

Note 5: Rise and fall times are measured using 10% and 90% levels.

TYPICAL PERFORMANCE CHARACTERISTICS $T_A = 25^\circ\text{C}$, unless otherwise noted.

PWM Pin Thresholds vs Temperature

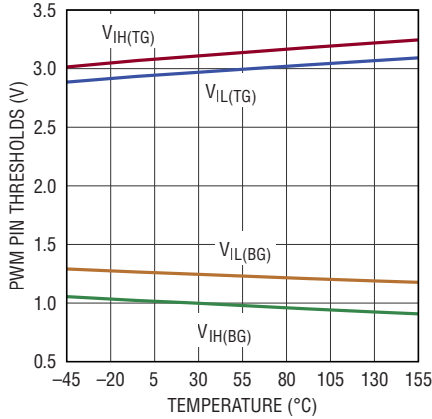

7060 G01

EN Pin Thresholds vs Temperature

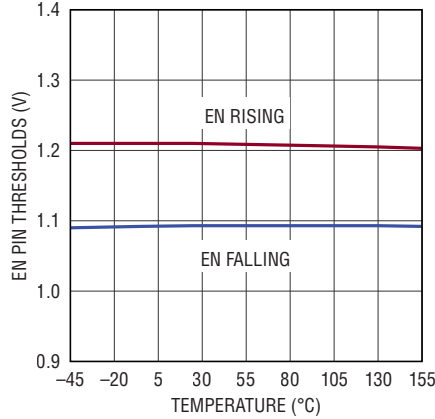

7060 G02

Quiescent Supply Current vs Supply Voltage

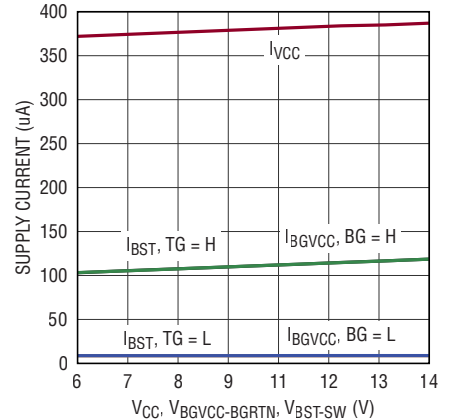

7060 G03

V_{CC} Undervoltage Lockout Thresholds vs Temperature

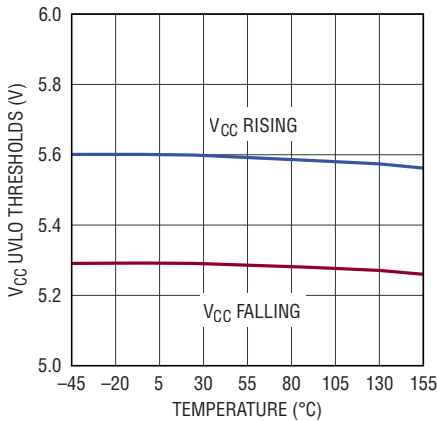

7060 G04

V_{CC} Overvoltage Lockout Thresholds vs Temperature

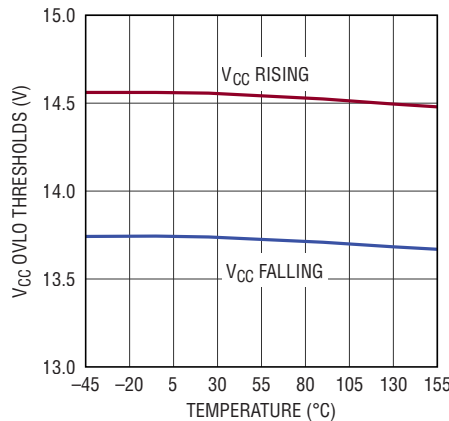

7060 G05

Supply Current vs Input Frequency

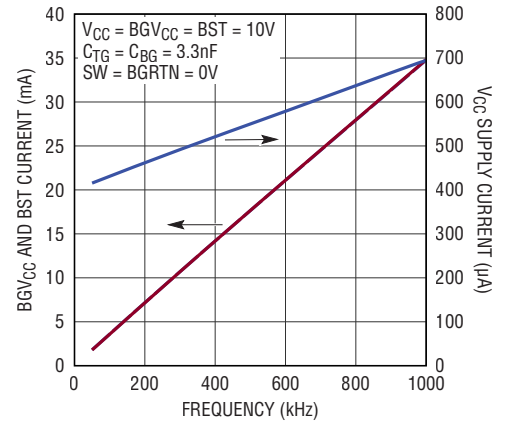

7060 G06

Switching Supply Current vs Load Capacitance

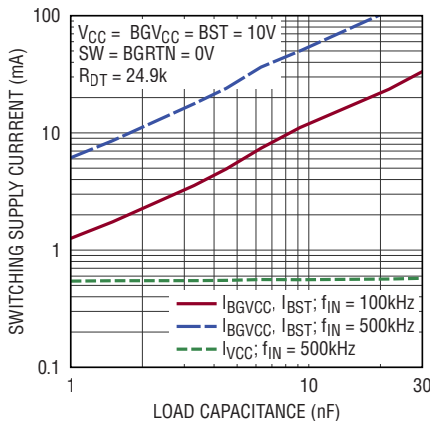

7060 G07

Rise and Fall Time vs Floating Supply Voltage

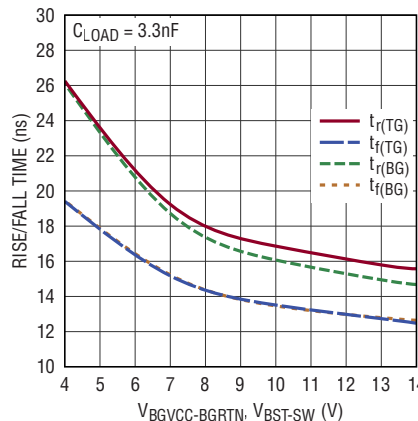

7060 G08

Rise and Fall Time vs Load Capacitance

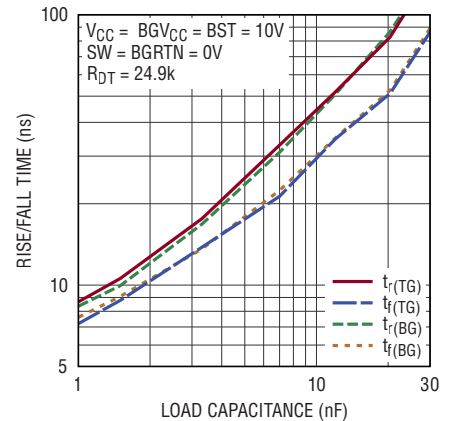

7060 G09

TYPICAL PERFORMANCE CHARACTERISTICS $T_A = 25^\circ\text{C}$, unless otherwise noted.

Propagation Delay vs Floating Supply Voltage

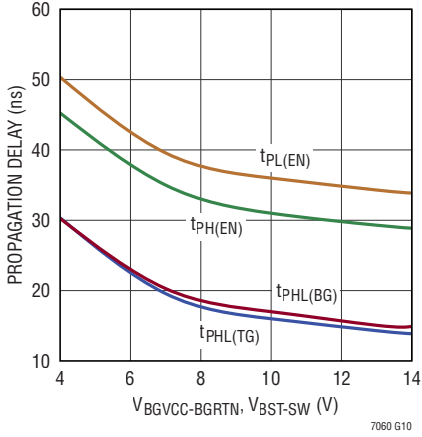

Propagation Delay vs Temperature

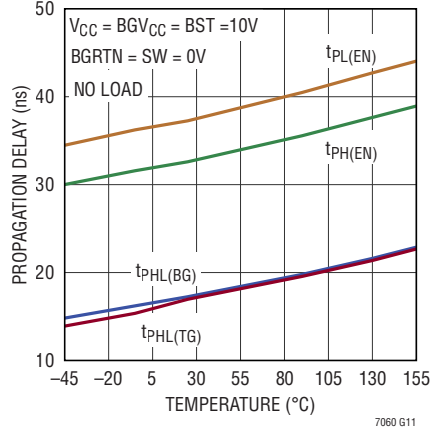

Dead-Time vs R_{DT}

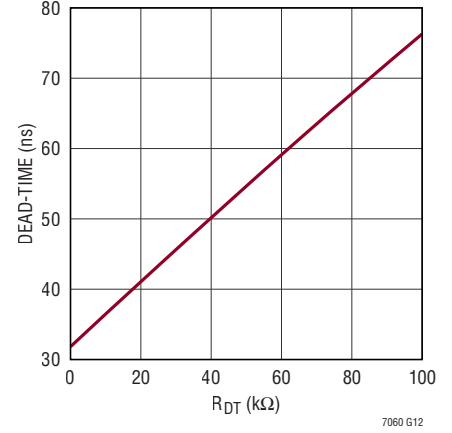

Dead-Time vs Floating Supply Voltage

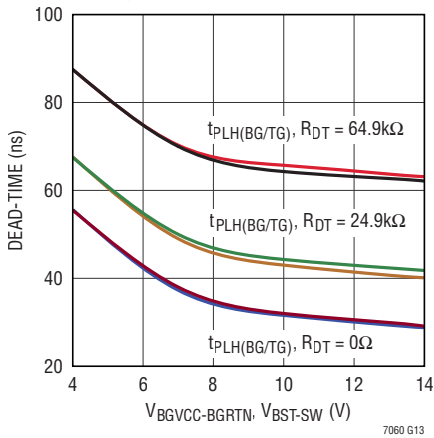

Dead-Time vs Temperature

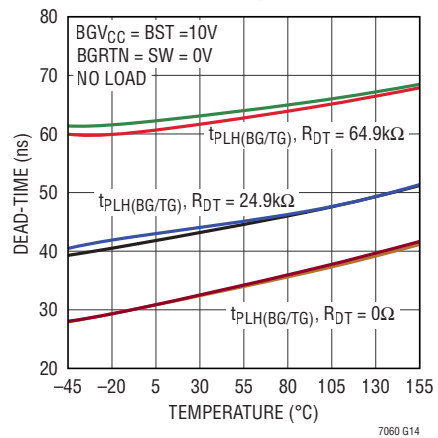

TG/BG Pull-Up and Pull-Down Resistance vs Temperature

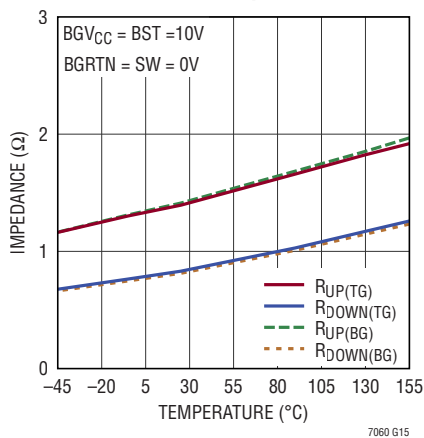

TG/BG Pull-Up and Pull-Down Resistance vs Floating Supply Voltage

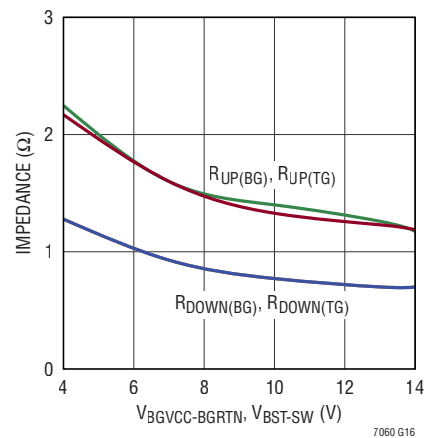

PIN FUNCTIONS

V_{CC}: V_{CC} Supply. IC bias supply referred to the SGND pin. An internal 4.5V supply is generated from the V_{CC} supply to bias most of the internal circuitry. A bypass capacitor with a minimum value of 0.1 μ F should be tied between this pin and the SGND pin.

BGV_{CC}: Bottom MOSFET Driver Supply. The bottom MOSFET gate driver is biased between this pin and the BGRTN pin. An external capacitor should be tied between this pin and BGRTN and placed close to the IC.

BGRTN: Bottom MOSFET Driver Return. The bottom gate driver is biased between BGV_{CC} and BGRTN. Kelvin connect BGRTN to the bottom MOSFET source pin for high noise immunity. The voltage difference between the BGRTN pin and the SGND can be -10V to 100V .

BG: Bottom MOSFET Gate Driver Output. This pin drives the gate of the N-channel MOSFET between BGRTN and BGV_{CC}.

BST: Top MOSFET Driver Supply. The top MOSFET gate driver is biased between this pin and the SW pin. An external capacitor should be tied between this pin and the SW pin and placed close to the IC.

SW: Top MOSFET Driver Return. The top gate driver is biased between BST and SW. Kelvin connect SW to the top MOSFET source pin for high noise immunity. The voltage difference between the SW pin and SGND can be -10V to 100V .

TG: Top MOSFET Gate Driver Output. This pin drives the gate of the N-channel MOSFET between SW and BST.

DT: Dead-Time Program Pin Referred to the SGND Pin. A single resistor from this pin to SGND sets the BG/TG low to TG/BG high propagation delay. See the operation section for details.

PWM: Three-State Gate Driver Input Signal Referred to the SGND Pin. The TG/BG state is determined by the voltage at this pin. If this pin is floating, an internal resistor divider triggers the High-Z mode in which both BG and TG are turned off. Trace capacitance on this pin should be minimized.

EN: Enable Control Input Pin Referred to the SGND Pin. A voltage on this pin above 1.2V enables the gate drivers. The TG and BG pins are both in the low state if this pin is logic low.

FLT: Open Drain Fault Output Pin Referred to the SGND Pin. Open-drain output that pulls to SGND during V_{CC} UVLO/OVLO and floating supplies UVLO condition. The typical pull-down resistance is 60 Ω .

NC: No Internal Connection. Always keep this pin floating. It is intentionally skipped to isolate adjacent high voltage pins.

SGND: Chip Ground. The exposed pad must be soldered to the PCB ground for electrical contact and for rated thermal performance.

BLOCK DIAGRAM

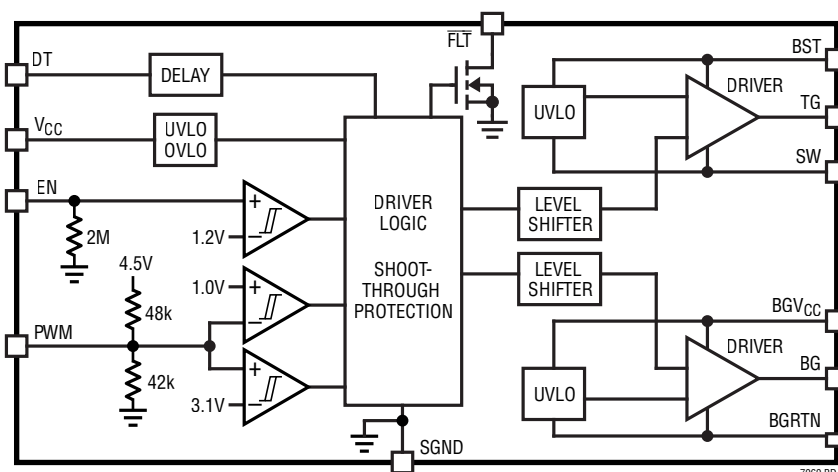

TIMING DIAGRAM

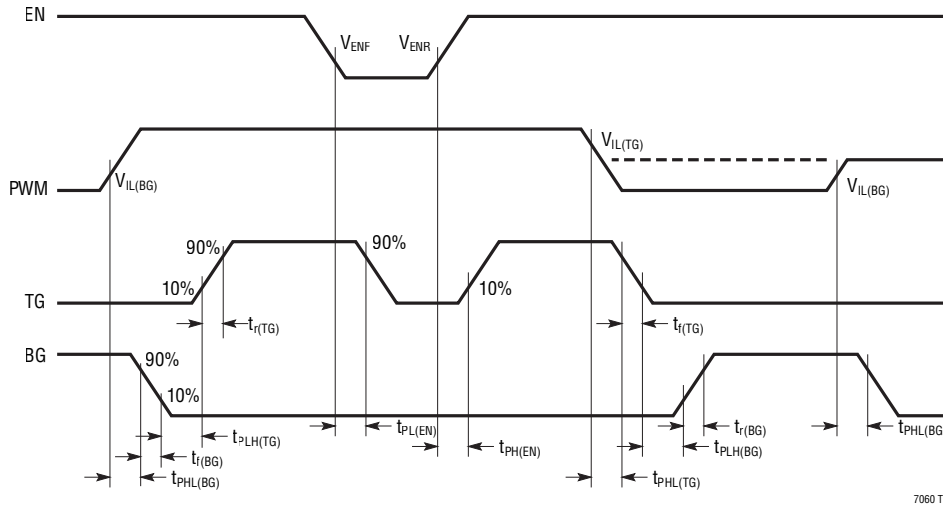

7060 TD

OPERATION

OVERVIEW

The LTC7060 receives a ground-referenced, low voltage digital PWM signal to drive two N-channel power MOSFETs in a half-bridge configuration. The gate of the low side MOSFET is driven high or low, swinging between BGV_{CC} and $BGRTN$, depending on the state of the PWM pin. Similarly, the gate of the high side MOSFET is driven complimentary to the low side MOSFET, swinging between BST and SW .

Both the low side and high side drivers are floating gate drivers. The unique double floating architecture makes the gate driver outputs robust and less sensitive to ground noise. The symmetric design allows the half-bridge output to be inverting or non-inverting of the input logic.

V_{CC} SUPPLY

V_{CC} is the power supply for the LTC7060's internal circuitry. An internal 4.5V supply is generated from the V_{CC} supply to bias most of the internal circuits referred to $SGND$. The V_{CC} pin may be tied to the BGV_{CC} pin if $SGND$ and $BGRTN$ are at the same potential. V_{CC} is independent of V_{IN} .

INPUT STAGE (PWM, EN)

The LTC7060 employs a three-state PWM input with fixed transition thresholds. The relationship between

the transition thresholds and three input states of the LTC7060 is illustrated in Figure 1. When the voltage on PWM is greater than the threshold $V_{IH(TG)}$, TG is pulled up to BST , turning the high side MOSFET on. This MOSFET will stay on until PWM falls below $V_{IL(TG)}$. Similarly, when PWM is less than $V_{IH(BG)}$, BG is pulled up to BGV_{CC} , turning the low side MOSFET on. BG will stay high until PWM increases above the threshold $V_{IL(BG)}$.

The hysteresis between the corresponding V_{IH} and V_{IL} voltage levels eliminates false triggering due to the noise during switch transitions. However, care should be taken to keep noise from coupling into the PWM pin, particularly in high frequency, high voltage applications.

The thresholds are positioned to allow for a region in which both BG and TG are low. An internal resistor divider

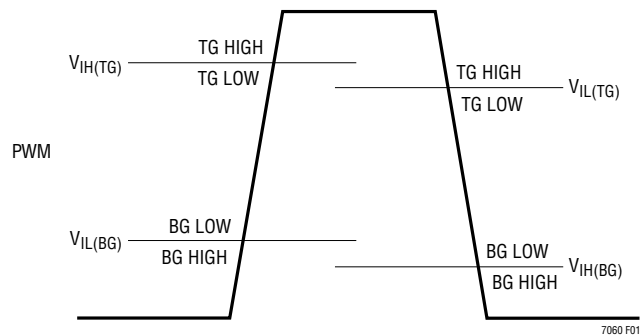

7060 F01

Figure 1. Three-State PWM Operation

OPERATION

sets the PWM pin voltage into this region if the signal driving the PWM pin goes into a high impedance state.

The EN pin can also be used to keep both BG and TG low if the high impedance state is not available from the PWM driving signal. Driving the EN pin low keeps both TG and BG off, and driving the EN pin high enables TG and BG switching based on the PWM input. There is an internal $2\text{M}\Omega$ pull-down resistor from the EN pin to SGND, keeping the EN default state low if its input is not driven.

Both three-state PWM and EN pin can be used by the controller IC to perform the Discontinuous Conduction Mode (DCM) in switching regulator applications.

OUTPUT STAGE

A simplified version of the LTC7060's output stage is shown in Figure 2. The BG and TG design are symmetric and they both have floating gate driver outputs. The pull-up device is a PMOS with a typical 1.5Ω $R_{DS(ON)}$ and the pull-down device is a NMOS with a typical 0.8Ω $R_{DS(ON)}$. The wide driver supply voltage ranging from 4V to 14V enables the driving of different power MOSFETs, such as logic level or higher threshold MOSFETs. However, the LTC7060 is optimized for higher threshold MOSFETs (e.g. $BST-SW = 10\text{V}$ and $BGV_{CC}-BGRN = 10\text{V}$). The driver

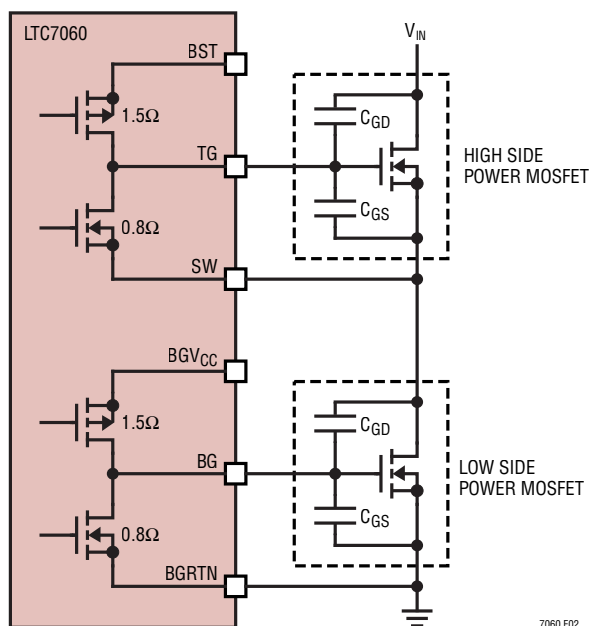

Figure 2. Simplified Output Stage in Half-Bridge Configuration

output pull-up and pull-down resistance may increase with lower driver supply voltage.

Since the power MOSFETs generally account for the majority of the power loss in a converter, it is important to turn them on and off quickly, thereby minimizing the transition time and power loss. The LTC7060's typical 1.5Ω pull-up resistance and 0.8Ω pull-down resistance are equivalent to 3A peak pull-up current and 6A peak pull down current at a 10V driver supply. Both BG and TG can produce a rapid turn-on transition for the MOSFETs with capability of driving a 3.3nF load with 18ns rise time.

Furthermore, a strong pull-down on the driver outputs prevents cross-conduction current. For example, in the half-bridge configuration shown in Figure 2, when BG turns the low side power MOSFET off and TG turns the high side power MOSFET on, the voltage on the SW pin could rise to V_{IN} very rapidly. This high frequency positive voltage transient will couple through the C_{GD} capacitance of the low side power MOSFET to the BG pin. If the BG pin is not held down sufficiently, the voltage on the BG pin could rise above the threshold voltage of the low side power MOSFET, momentarily turning it back on. As a result, both the high side and low side MOSFETs would be conducting, which would cause significant cross-conduction current to flow through the MOSFETs from V_{IN} to ground, thereby incurring substantial power loss and potentially damaging the MOSFETs. For this reason, short PCB traces for the BG and TG pins, which minimize the parasitic inductances, are recommended.

PROTECTION CIRCUITRY

When using the LTC7060, care must be taken not to exceed any of the ratings specified in the Absolute Maximum Ratings section. As an added safeguard, the LTC7060 incorporates overtemperature shutdown feature. If the junction temperature reaches approximately 180°C , the LTC7060 will enter thermal shutdown mode and BG will be pulled to BGRN; TG will be pulled to SW. Normal operation will resume when the junction temperature cools down below 165°C . The overtemperature level is not production tested. The LTC7060 is guaranteed to operate below 150°C .

OPERATION

The LTC7060 contains both undervoltage and overvoltage lockout detectors that monitor the V_{CC} supply. When V_{CC} falls below 5.3V or rises above 14.6V, BG and TG pins are pulled to BGRTN and SW, respectively, turning off both the external MOSFETs. When V_{CC} has adequate supply voltage but less than the overvoltage threshold, normal operation will resume.

Additional undervoltage lockout circuitry is included in each floating driver supply. The BG will be pulled down to BGRTN when the floating voltage from BGV_{CC} to BGRTN falls below 3.3V. Similarly, the TG will be pulled down to SW when the floating voltage from BST to SW is less than 3.3V.

The normal operation and undervoltage/overvoltage logic table is shown in Table 1.

Table 1. Normal Operation and Undervoltage/Overvoltage Logic

PWM	EN	V_{CC} UVLO or OVLO	(BST-SW) UVLO	(BGV_{CC} - BGRTN) UVLO	TG	BG
X	L	X	X	X	L	L
X	X	Y	X	X	L	L
L	H	N	X	N	L	H
L	H	N	X	Y	L	L
H	H	N	N	X	H	L
H	H	N	Y	X	L	L
HIGH-Z	H	X	X	X	L	L

Note: "X" means "Don't Care"

ADAPTIVE SHOOT-THROUGH PROTECTION

Internal adaptive shoot-through protection circuitry monitors the external MOSFETs to ensure that they do not conduct simultaneously. The LTC7060 does not allow the bottom MOSFET to turn on until the gate-source voltage on the top MOSFET is sufficiently low, and vice-versa. This feature improves efficiency and reliability by eliminating potential shoot-through current through the MOSFETs during switching transitions.

PROGRAMMABLE DEAD-TIME

To ensure robust shoot-through protection in high voltage half-bridge configuration and switched capacitor converter

applications, the LTC7060 provides a DT pin which can be used to program the propagation delay during BG/TG low to TG/BG high transition (Dead-Time). An external resistor (R_{DT}) from the DT pin to the SGND equally sets both the BG low to TG high propagation delay and the TG low to BG high propagation delay. Their relationship can be seen in Figure 3. The Dead-Time can be estimated by the following equation when the R_{DT} is less than 100k Ω :

$$\text{Dead-Time} = R_{DT} \cdot 0.44\text{ns/k}\Omega + 32\text{ns}$$

If the DT pin is shorted to SGND, the Dead-Time is 32ns. If the DT Pin is floating, the Dead-Time is around 250ns.

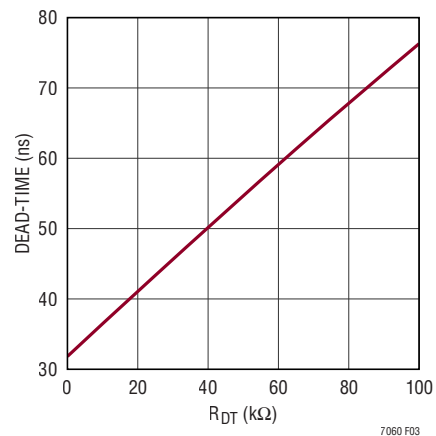

Figure 3. Dead-Time vs R_{DT}

FAULT FLAG

The $\overline{\text{FLT}}$ pin is connected to the open-drain of an internal N-channel MOSFET. It needs a pull-up resistor (e.g. 51k) tied to a supply such as V_{CC} or any other bias voltage up to 15V. The $\overline{\text{FLT}}$ pin is pulled low to SGND immediately if any of these conditions are met:

- The V_{CC} is below its UVLO threshold or above its OVLO threshold.
- (BGV_{CC} -BGRTN) is below its UVLO threshold.
- (BST-SW) is below its UVLO threshold.
- The junction temperature reaches approximately 180°C.

When all the faults are cleared, the $\overline{\text{FLT}}$ pin is pulled up by the external resistor after a built-in 100 μ s delay.

APPLICATIONS INFORMATION

BOOTSTRAPPED SUPPLY (BGV_{CC}-BGRTN, BST-SW)

Either or both of the BGV_{CC}-BGRTN and BST-SW supplies can be bootstrapped supplies. An external boost capacitor, C_B, connected between BGV_{CC} and BGRTN, or between BST and SW, supplies the gate driver voltage for its respective MOSFET driver. When the external MOSFET is turned on, the driver places the C_B voltage across the gate-source of the MOSFET. This enhances the MOSFET and turns it on.

The charge to turn on the external MOSFET is referred to gate charge, Q_G, and is typically specified in the external MOSFET data sheet. The boost capacitor, C_B, needs to have at least 10 times the gate capacitance to turn on the external MOSFET fully. Gate charge can range from 5nC to hundreds of nC and is influenced by the gate drive level and type of external MOSFET used. For most applications, a capacitor value of 0.1uF for C_B will be sufficient. However, if multiple MOSFETs are paralleled and driven by the LTC7060, C_B capacitance needs to be increased correspondingly.

An external supply, typically V_{CC} connected through a Schottky diode, is required to keep the C_B charged. The LTC7060 does not charge the C_B and always discharges the C_B. When the BG/TG is high, the total current from BGV_{CC}/BST to BGRTN/SW and SGND is typically 100μA; when the BG/TG is low, the total current from BGV_{CC}/BST is typically 8μA.

POWER DISSIPATION

To ensure proper operation and long-term reliability, the LTC7060 must not operate beyond its maximum temperature rating. Package junction temperature can be calculated by:

$$T_J = T_A + (P_D)(\theta_{JA})$$

where:

T_J = junction temperature

T_A = ambient temperature

P_D = power dissipation

θ_{JA} = junction-to-ambient thermal resistance

Power dissipation consists of standby, switching and capacitive load power losses:

$$P_D = P_{DC} + P_{AC} + P_{QG}$$

where:

P_{DC} = quiescent power loss

P_{AC} = internal switching loss at input frequency f_{IN}

P_{QG} = loss due to turning on and off external MOSEFT with gate charge Q_G at frequency f_{IN}

The LTC7060 consumes very little quiescent current. The DC power loss at V_{CC} = 10V is only (10V)(0.4mA) = 4mW.

At a particular switching frequency, the internal power loss increases due to both AC currents required to charge and discharge internal nodal capacitances and cross-conduction currents in the internal logic gates. The sum of the quiescent current and internal switching current with no load are shown in the Typical Performance Characteristics plot of Switching Supply Current vs Input Frequency.

The gate charge losses are primarily due to the large AC currents required to charge and discharge the capacitance of the external MOSFETs during switching. For identical pure capacitive loads C_{LOAD} on BG and TG at switching frequency f_{IN}, the load losses would be:

$$P_{CLOAD} = (C_{LOAD})(f_{IN})[(V_{BST-SW})^2 + (V_{BGVCC-BGRTN})^2]$$

In a typical synchronous buck configuration, the V_{CC} is connected to the power for the bottom MOSFET driver, BGV_{CC}. V_{BST-SW} is equal to V_{CC} - V_D, where V_D is the forward voltage drop of the external Schottky diode between V_{CC} and BST. If this drop is small relative to V_{CC}, the load losses can be approximated as:

$$P_{CLOAD} \approx 2(C_{LOAD})(f_{IN})(V_{CC})^2$$

Unlike a pure capacitive load, a power MOSFET's gate capacitance seen by the driver output varies with its V_{GS} voltage level during switching. A MOSFET's capacitive load power dissipation can be calculated using its gate charge, Q_G. The Q_G value corresponding to the MOSFET's V_{GS} value (V_{CC} in this case) can be readily obtained from the manufacturer's Q_G vs V_{GS} curves. For identical MOSFETs on BG and TG:

$$P_{QG} \approx 2(Q_G)(f_{IN})(V_{CC})$$

APPLICATIONS INFORMATION

BYPASSING AND GROUNDING

The LTC7060 requires proper bypassing on the V_{CC} , V_{BST-SW} , and $V_{BGVCC-BGRTN}$ supplies due to its high speed switching (nanoseconds) and large AC currents (amperes). Careless component placement and PCB trace routing may cause excessive ringing and under/overshoot.

To obtain the optimum performance from the LTC7060:

- Mount the bypass capacitors as close as possible between the V_{CC} and SGND pins, the BGV_{CC} and BGRTN pins, and the BST and SW pins. The leads should be shortened as much as possible to reduce lead inductance.
- Use a low inductance, low impedance ground plane to reduce any ground drop and stray capacitance. Remember that the LTC7060 switches greater than 5A peak currents and any significant ground drop will degrade signal integrity.
- Plan the power/ground routing carefully. Know where the large load switching current is coming from and going to. Maintain separate ground return paths for the input pin and the output power stage.
- Kelvin connect the TG pin to the top MOSFET gate and SW pin to the top MOSFET source. Kelvin connect the BG pin to the bottom MOSFET gate and BGRTN to the bottom MOSFET source. Keep the copper trace between the driver output pin and load short and wide.
- Be sure to solder the Exposed Pad on the back side of the LTC7060 packages to the board. Failure to make good thermal contact between the exposed back side and the copper board will result in thermal resistances far greater than specified for the packages.

TYPICAL APPLICATIONS

High Efficiency 6-Phase, 12V, 180A Supply

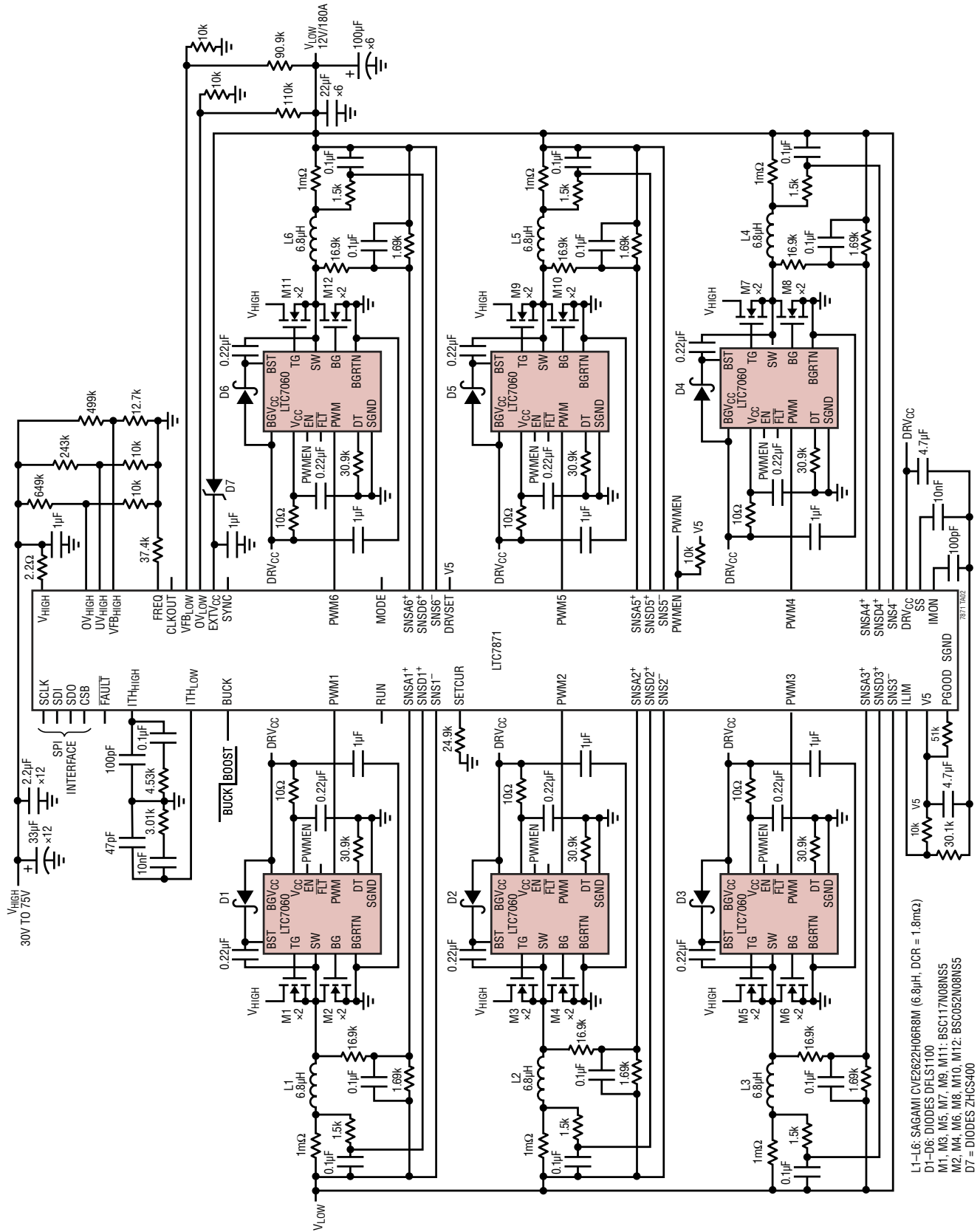

- L1-L6: SAGAMI CVE2622H06R8M (6.8µH, DCR = 1.8mΩ)
- D1-D6: DIODES DFLS1100
- M1, M3, M5, M7, M9, M11: BSC117N08NS5
- M2, M4, M6, M8, M10, M12: BSC052N08NS5
- D7 = DIODES ZHCS400

TYPICAL APPLICATIONS

Up to 100A High Efficiency 4 to 1 Switched Capacitor Converter

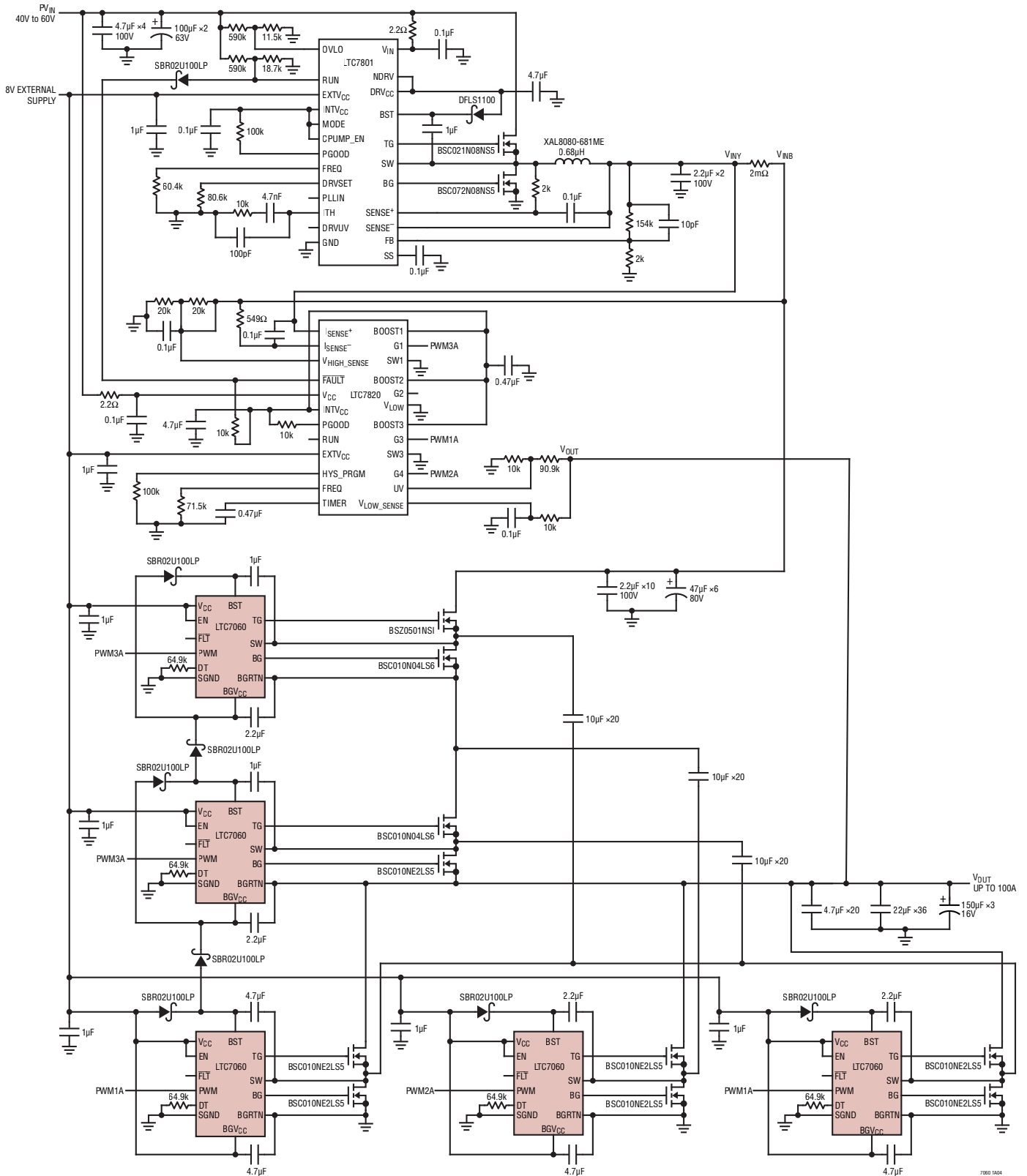

7180 100A

PACKAGE DESCRIPTION

MSE Package
12-Lead Plastic MSOP, Exposed Die Pad
 (Reference LTC DWG # 05-08-1666 Rev G)

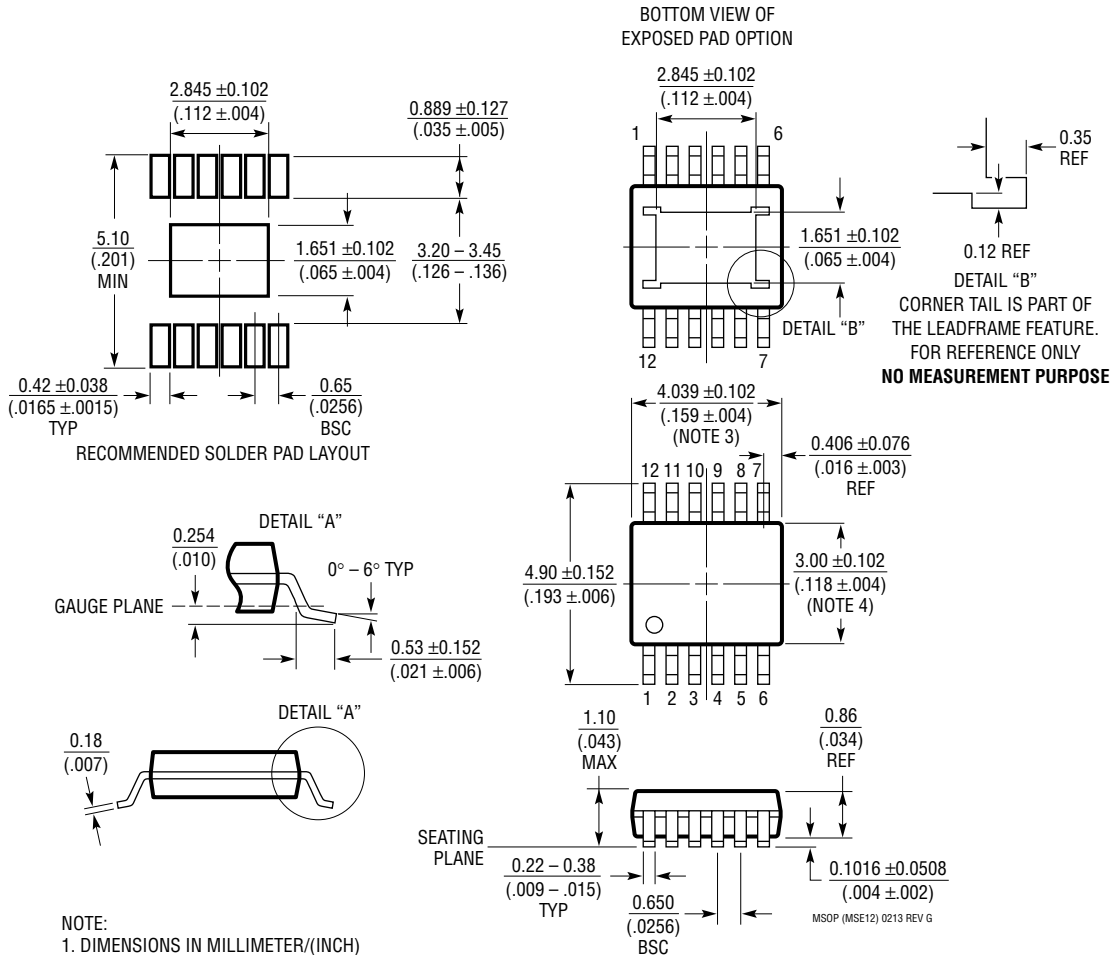

- NOTE:
1. DIMENSIONS IN MILLIMETER/(INCH)
 2. DRAWING NOT TO SCALE
 3. DIMENSION DOES NOT INCLUDE MOLD FLASH, PROTRUSIONS OR GATE BURRS. MOLD FLASH, PROTRUSIONS OR GATE BURRS SHALL NOT EXCEED 0.152mm (.006") PER SIDE
 4. DIMENSION DOES NOT INCLUDE INTERLEAD FLASH OR PROTRUSIONS. INTERLEAD FLASH OR PROTRUSIONS SHALL NOT EXCEED 0.152mm (.006") PER SIDE
 5. LEAD COPLANARITY (BOTTOM OF LEADS AFTER FORMING) SHALL BE 0.102mm (.004") MAX
 6. EXPOSED PAD DIMENSION DOES INCLUDE MOLD FLASH. MOLD FLASH ON E-PAD SHALL NOT EXCEED 0.254mm (.010") PER SIDE.

REVISION HISTORY

REV	DATE	DESCRIPTION	PAGE NUMBER
A	04/20	Updated Order Information.	2
		R _{DT} changed from 64.9k Ω to 100k Ω in I _{VCC} row.	3
B	02/22	Updated AEC-Q100 statement to qualified.	1

TYPICAL APPLICATION

High Input Voltage Buck Converter

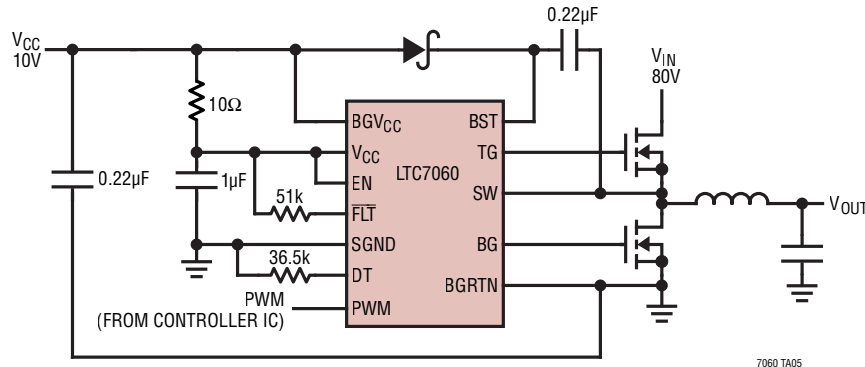

RELATED PARTS

PART NUMBER	DESCRIPTION	COMMENTS
LTC4449	High Speed Synchronous N-Channel MOSFET Driver	Up to 38V Supply Voltage, $4V \leq V_{CC} \leq 6.5V$, 3.2A Peak Pull-Up/4.5A Peak Pull-Down
LTC4442/ LTC4442-1	High Speed Synchronous N-Channel MOSFET Driver	Up to 38V Supply Voltage, $6V \leq V_{CC} \leq 9.5V$, 2.4A Peak Pull-Up/5A Peak Pull-Down
LTC4446	High Voltage Synchronous N-Channel MOSFET Driver without Shoot-Through Protection	Up to 100V Supply Voltage, $7.2V \leq V_{CC} \leq 13.5V$, 2.5A Peak Pull-Up/3A Peak Pull-Down
LTC4444/ LTC4444-5	High Voltage Synchronous N-Channel MOSFET Driver with Shoot-Through Protection	Up to 100V Supply Voltage, $4.5V/7.2V \leq V_{CC} \leq 13.5V$, 2.5A Peak Pull-Up/3A Peak Pull-Down
LTC3774	Dual, Multiphase Current Mode Synchronous Step-Down DC/DC Controller for Sub-Milliohm DCR Sensing	Operates with DrMOS, Power Blocks or External Drivers/MOSFETs, $4.5V \leq V_{IN} \leq 38V$, $0.6V \leq V_{OUT} \leq 3.5V$
LTC3861	Dual, Multiphase Step-Down Voltage Mode DC/DC Controller with Accurate Current Sharing	Operates with Power Blocks, DrMOS or External MOSFETs, $3V \leq V_{IN} \leq 24V$
LTC7851	Quad Output, Multiphase Step-Down Voltage Mode DC/DC Controller with Accurate Current Sharing	Operates with DrMOS, Power Blocks or External Drivers/MOSFETs, V_{IN} Range Depends on External Components, $3V \leq V_{CC} \leq 5.5V$, $0.6V \leq V_{OUT} \leq V_{CC} - 0.5V$
LTC7820	Fixed Ratio High Power Inductorless (Charge Pump) DC/DC Controller	$6V \leq V_{IN} \leq 72V$, 2:1 Voltage Divider, 1:2 Voltage Doubler, 1:1 Voltage Inverter, Low Noise Soft Switching, 4mm × 5mm QFN-28
LTC7821	Hybrid Step-Down Synchronous Controller	$10V \leq V_{IN} \leq 72V$, $0.9V \leq V_{OUT} \leq 20V$, Low Noise Soft Switching, 5mm × 5mm QFN-32
LTC7871	Six-Phase, Synchronous Bidirectional Buck or Boost Controller	V_{HIGH} up to 100V, V_{LOW} up to 60V, SPI Interface, 64-Lead LQFP
LTC7801	150V Low I_Q , Synchronous Step-Down DC/DC Controller, 100% Duty Cycle Capability, Adjustable 5V to 10V Gate Drive	$4V \leq V_{IN} \leq 140V$, $150V_{PK}$, $0.8V \leq V_{OUT} \leq 60V$, $I_Q = 40\mu A$, PLL Fixed Frequency 50kHz to 900kHz

Looking for pricing, stock, or lifecycle information?

Click below to explore more details on WIN SOURCE:

- ⊖ [View LTC7060IMSE#WPBF on WIN SOURCE](#)
- ⊖ [Analog Devices Inc. Information](#)

Optimize Your Supply Chain with WIN SOURCE Solutions

- ✓ Global Sourcing Solution
- ✓ Obsolete Management
- ✓ Cost Control Management
- ✓ Shortage Management
- ✓ Alternative Solution
- ✓ Excess Inventory Management