



**THE DATASHEET OF
TIOS101DMWT**



TIOS101, TIOS101x Digital Sensor Output Drivers with Integrated Surge Protection

1 Features

- **Functional Safety-Capable**
 - Documentation available to aid functional safety system design: [TIOS101](#), [TIOS1013](#), [TIOS1015](#)
- 7-V to 36-V Supply Voltage
- PNP, NPN or Push-Pull Configurable Output
- Low Residual Voltage of 1.75 V at 250 mA
- 50-mA to 350-mA Configurable Current Limit
- Tolerant to ± 65 -V Transients < 100 μ s
- Reverse Polarity Protection of up to 60 V on VCC, OUT and GND
- Integrated EMC Protection on VCC and OUT
 - ± 16 kV IEC 61000-4-2 ESD Contact Discharge
 - ± 4 kV IEC 61000-4-4 Electrical Fast Transient
 - ± 1.2 kV/500 Ω IEC 61000-4-5 Surge
- Fast Demagnetization of Inductive Loads up to 1.5 H
- Large Capacitive Load Driving Capability
- < 2.2-mA Quiescent Supply Current
- Integrated LDO Options for up to 20 mA Current
 - TIOS101: No LDO
 - TIOS1013: 3.3-V LDO
 - TIOS1015: 5-V LDO
- Overtemperature Warning and Thermal Protection
- Fault Indicator
- Extended Ambient Temperature: -40°C to 125°C
- 2.5 mm x 3 mm 10-pin VSON Package

2 Applications

- Proximity Switches
- Capacitive and Inductive Sensors
- Digital Outputs

3 Description

The TIOS101(x) devices are configurable as high-side, low-side or push-pull drivers. These devices are capable of withstanding up to 1.2 kV (500 Ω) of IEC 61000-4-5 surge and feature integrated reverse polarity protection.

A simple pin-programmable interface allows easy interfacing to the controller circuits. The output current limit can be configured using an external resistor.

Fault reporting and internal protection functions are provided for under voltage, over circuit current and over temperature.

Device Information

PART NUMBER	PACKAGE ⁽¹⁾	BODY SIZE (NOM)
TIOS101	VSON (10)	2.50 mm x 3.00 mm
TIOS1013		
TIOS1015		

(1) For all available devices, see the orderable addendum at the end of the data sheet.

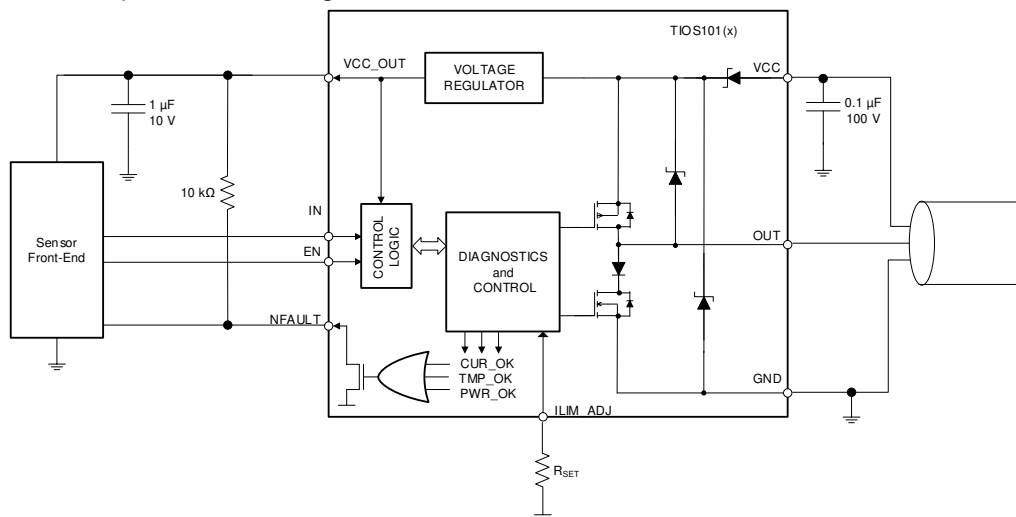

Typical Application Diagram



Table of Contents

1 Features	1	8.2 Functional Block Diagrams.....	9
2 Applications	1	8.3 Feature Description.....	10
3 Description	1	8.4 Device Functional Modes.....	15
4 Revision History	2	9 Application Information Disclaimer	17
5 Pin Configuration and Functions	3	9.1 Application Information.....	17
6 Specifications	4	9.2 Typical Application.....	17
6.1 Absolute Maximum Ratings.....	4	10 Power Supply Recommendations	21
6.2 ESD Ratings.....	4	11 Layout	22
6.3 Recommended Operating Conditions.....	4	11.1 Layout Guidelines.....	22
6.4 Thermal Information.....	5	11.2 Layout Example.....	22
6.5 Electrical Characteristics.....	5	12 Device and Documentation Support	23
6.6 Switching Characteristics.....	6	12.1 Receiving Notification of Documentation Updates.....	23
6.7 Typical Characteristics.....	7	12.2 Support Resources.....	23
7 Parameter Measurement Information	8	12.3 Trademarks.....	23
8 Detailed Description	9	12.4 Electrostatic Discharge Caution.....	23
8.1 Overview.....	9	12.5 Glossary.....	23

4 Revision History

Changes from Revision B (June 2019) to Revision C (February 2021) Page

- Added Functional Safety to the *Features* list 1

Changes from Revision A (August 2018) to Revision B (June 2019) Page

- Added device numbers TIOS1013 and TIOS1015 to the data sheet 1
- Changed all TIOS101-3 To: TIOS1013 and TIOS101-5 To: TIOS1015 1
- Changed *Feature* From: Reverse Polarity Protection of up to 55 V on VCC To: Reverse Polarity Protection of up to 60 V on VCC 1
- Changed the Supply voltage values From: MIN = –55 V, MAX = 50 V To: MIN = –60 V, MAX = 60 V in the *Absolute Maximum Ratings* 4
- Changed the Voltage difference Max value From: 55 V To: 60 V in the *Absolute Maximum Ratings* 4
- Changed |55 V| To: |60 V| in the Leakage current Test Conditions in the Electrical Characteristics..... 5
- Changed text From: "not exceed 55 V DC at any time." To: "not exceed 60 V DC at any time." in the *Reverse Polarity Protection* section..... 13

Changes from Revision * (July 2017) to Revision A (August 2018) Page

- Changed the *Thermal Information* table values..... 5

5 Pin Configuration and Functions

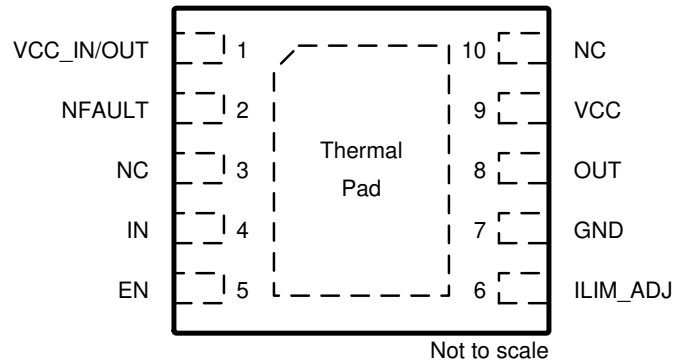

Figure 5-1. DMW Package, 10-Pin (VSON), Top View

Table 5-1. Pin Functions

PIN		I/O	DESCRIPTION
NAME	NO.		
OUT	8	O	Switch output
VCC	9	POWER	Supply voltage (24 V nominal)
GND	7	POWER	Device ground
EN	5	I	Driver enable input signal from the local controller. Logic low sets the OUT output at Hi-Z. Weak internal pull-down.
IN	4	I	Transmit data input from the local controller. No effect if EN is low. Logic high sets low-side switch. Logic low sets high-side switch. Weak internal pull-up.
VCC_IN/OUT	1	POWER	3.3-V or 5-V linear regulator output; external 3.3-V or 5-V logic supply input for option without LDO.
ILIM_ADJ	6	I	Input for current limit adjustment. Connect resistor R_{SET} between ILIM_ADJ and GND.
NFAULT	2	OPEN-DRAIN	Fault indicator output signal to the microcontroller. A low level indicates either an over-current, an undervoltage in supply or an overtemperature condition. Connect this pin via pull-up resistor to VCC_IN/OUT.
NC	3, 10	—	No internal connection.
Thermal Pad	—	—	Connect to GND plane for optimal thermal and electrical performance

6 Specifications

6.1 Absolute Maximum Ratings

over operating free-air temperature range (unless otherwise noted)⁽¹⁾ ⁽²⁾

		MIN	MAX	UNIT
Supply voltage	Steady state voltage for VCC and OUT	-60	60	V
	Transient pulse width < 100 μ s for VCC and OUT	-65	65	V
Voltage difference	$ V_{(VCC)} - V_{(OUT)} $		60	V
Logic supply voltage (TIOS101)	VCC_IN	-0.3	6	V
Input logic voltage	IN, EN, ILIM_ADJ	-0.3	6	V
Output current	NFAULT	-5	5	mA
Storage temperature, T _{stg}		-55	170	°C

- (1) Stresses beyond those listed under *Absolute Maximum Ratings* may cause permanent damage to the device. These are stress ratings only, which do not imply functional operation of the device at these or any other conditions beyond those indicated under *Recommended Operating Conditions*. Exposure to absolute-maximum-rated conditions for extended periods may affect device reliability.
- (2) All voltages are with reference to the GND pin, unless otherwise specified.

6.2 ESD Ratings

			VALUE	UNIT
V _(ESD)	Electrostatic discharge	Human-body model (HBM), per ANSI/ESDA/JEDEC JS-001 ⁽¹⁾	±4000	V
		Contact discharge, per IEC 61000-4-2 ⁽²⁾ ⁽³⁾	±16000	
		Electrical fast transient, per IEC 61000-4-4 ⁽²⁾	±4000	
		Surge protection with 500 Ω , per IEC 61000-4-5; 1.2/50 μ s ⁽²⁾	±1200	
		All pins		
		Pins VCC, OUT and GND		

- (1) JEDEC document JEP155 states that 500-V HBM allows safe manufacturing with a standard ESD control process.
- (2) Minimum 100-nF capacitor is required between VCC and GND. Minimum 1- μ F capacitor is required between VCC_IN/OUT and GND.
- (3) Passing level is \pm 4500 V if the device is powered and EN=IN=HIGH.

6.3 Recommended Operating Conditions

over operating free-air temperature range (unless otherwise noted)

		MIN	NOM	MAX	UNIT	
V _(VCC)	Supply voltage	7	24	36	V	
V _(VCC_IN)	Logic level input voltage (TIOS101 only)	3.3 V configuration	3	3.3	3.6	V
		5 V configuration	4.5	5	5.5	V
R _{SET}	External resistor for OUT current limit	0		100	k Ω	
1/t _{BIT}	Signaling rate (push-pull mode)			250	kbps	
I _(VCC_OUT)	LDO output current (TIOS1013 and TIOS1015 only)			20	mA	
T _A	Operating ambient temperature	-40		125	°C	
T _J	Junction temperature			150	°C	

6.4 Thermal Information

THERMAL METRIC ⁽¹⁾		TIOS101(x)	UNIT
		DMW (10 Pins)	
R _{θJA}	Junction-to-ambient thermal resistance	68.1	°C/W
R _{θJC(top)}	Junction-to-case (top) thermal resistance	60.1	°C/W
R _{θJB}	Junction-to-board thermal resistance	40.6	°C/W
Ψ _{JT}	Junction-to-top characterization parameter	13.4	°C/W
Ψ _{JB}	Junction-to-board characterization parameter	40.7	°C/W
R _{θJC(bot)}	Junction-to-case (bottom) thermal resistance	25.2	°C/W

(1) For more information about traditional and new thermal metrics, see the [Semiconductor and IC Package Thermal Metrics](#) application report.

6.5 Electrical Characteristics

over operating free-air temperature range (unless otherwise noted)

PARAMETER		TEST CONDITIONS	MIN	TYP	MAX	UNIT
POWER SUPPLIES (VCC)						
I _(VCC)	Quiescent supply current	EN = LOW, no load		1.5	2.2	mA
		EN = HIGH, no load		2	2.7	mA
LOGIC-LEVEL INPUTS (EN, IN)						
V _{IL}	Input logic low voltage				0.8	V
V _{IH}	Input logic high voltage		2			V
R _{PD}	Pull-down (EN) resistance			100		kΩ
R _{PU}	Pull-up (IN) resistance			200		kΩ
CONTROL OUTPUT (NFAULT)						
V _{OL}	Output logic low voltage	I _O = 4 mA			0.5	V
I _{OZ}	Output high impedance leakage	Output in Hi-Z, V _O = 0 V or VCC_IN/OUT	-1		1	μA
DRIVER OUTPUT (OUT)						
V _{DS(ON)}	High-side driver residual voltage	I = 250 mA			1.75	V
		I = 200 mA			1.5	V
		I = 100 mA			1.1	V
	Low-side driver residual voltage	I = 250 mA			1.75	V
		I = 200 mA			1.5	V
		I = 100 mA			1.1	V
I _P	OUT pull-up/down current	EN = LOW, IN = LOW, pull-down current	40	50	80	μA
		EN = LOW, IN = HIGH, pull-up current	40	50	80	μA
I _{O(LIM)}	Driver output current limit	R _{SET} = 100 kΩ	35	50	70	mA
		R _{SET} = 0 kΩ	300	350	400	mA
		R _{SET} = OPEN ⁽¹⁾	300	350	400	mA
PROTECTION CIRCUITS						
V _(UVLO)	VCC under voltage lockout	VCC falling; NFAULT = Hi-Z			6	V
		VCC rising; NFAULT = LOW			6.5	V
V _(UVLO,HYS)	VCC under voltage hysteresis	Rising to falling threshold	100			mV
V _(UVLO_IN)	VCC_IN under voltage lockout (No LDO option)	VCC_IN falling; NFAULT = Hi-Z		2.4		V
		VCC_IN rising; NFAULT = LOW		2.5		V
V _(UVLO,HYS)	VCC_IN under voltage hysteresis (No LDO option)	Rising to falling threshold		100		mV
T _(WRN)	Thermal warning		125			°C
T _(SDN)	Thermal shutdown	Die temperature T _J	150	160		°C
T _(HYS)	Thermal hysteresis for shutdown			10		°C

6.5 Electrical Characteristics (continued)

over operating free-air temperature range (unless otherwise noted)

PARAMETER		TEST CONDITIONS	MIN	TYP	MAX	UNIT
I_{REV}	Leakage current in reverse polarity	$V_{(OUT)} < V_{(VCC)}$ or $V_{(OUT)} > V_{(VCC)}$ up to 36 V			50	μA
		$V_{(OUT)} < V_{(OUT)}$ or $V_{(OUT)} > V_{(VCC)}$ up to 60 V			80	μA
		EN = HIGH, IN = LOW; $V_{(OUT \text{ to } VCC)} = 3 \text{ V}$			550	μA
		EN = HIGH, IN = HIGH; $V_{(OUT \text{ to } GND)} = -3 \text{ V}$			10	μA
LINEAR REGULATOR (LDO)						
$V_{(VCC_OUT)}$	Voltage regulator output	TIOS1015	4.75	5	5.25	V
		TIOS1013	3.13	3.3	3.46	V
$V_{(DROP)}$	Voltage regulator drop-out voltage ($V_{(VCC)} - V_{(VCC_OUT)}$)	$I_{CC} = 20 \text{ mA}$ load current	TIOS1015		1.9	V
			TIOS1013		2.3	V
REG	Line regulation ($dV_{(VCC_OUT)}/dV_{(VCC)}$)	$I_{(VCC_OUT)} = 1 \text{ mA}$			1.7	mV/V
L_{REG}	Load regulation ($dV_{(VCC_OUT)}/V_{(VCC_OUT)}$)	$V_{(VCC)} = 24 \text{ V}$, $I_{(VCC_OUT)} = 100 \mu A$ to 20 mA			1%	
PSSR	Power Supply Rejection Ratio	100 kHz, $I_{(VCC_OUT)} = 20 \text{ mA}$		40		dB

(1) Current fault indication will be active. Current fault auto recovery will be de-activated.

6.6 Switching Characteristics

over operating free-air temperature range (unless otherwise noted)

PARAMETER		TEST CONDITIONS	MIN	TYP	MAX	UNIT	
t_{PLH} , t_{PHL}	Driver propagation delay	See Figure 7-1 See Figure 7-2 See Figure 7-3 $R_L = 2 \text{ k}\Omega$ $C_L = 5 \text{ nF}$ $R_{(SET)} = 0 \Omega$		600	800	ns	
$t_{P(skew)}$	Driver propagation delay skew. $ t_{PLH} - t_{PHL} $			100		ns	
t_{PZH} , t_{PZL}	Driver enable delay					4	μs
t_{PHZ} , t_{PLZ}	Driver disable delay					4	μs
t_r , t_f	Driver output rise, fall time					150	ns
$ t_r - t_f $	Difference in rise and fall time					50	ns
t_{SC}	Current fault blanking time			175	200		μs
t_{pSC}	Current fault indication delay					260	μs
t_{SCEN}	Current fault driver re-enable wait time				15		ms
$t_{(UVLO)}$	OUT re-enable delay after UVLO (1)		$V_{(UVLO)}$ rising threshold crossing time to OUT enable time	10	30	50	ms

(1) OUT output remains Hi-Z for this time

6.7 Typical Characteristics

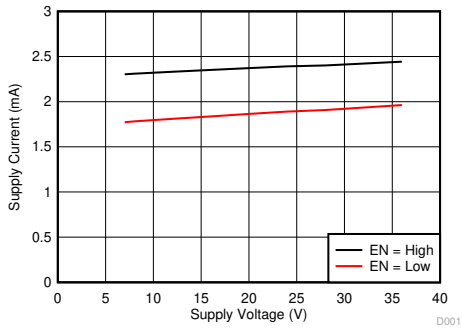

No load IN = OPEN 25°C

Figure 6-1. Supply Current vs Supply Voltage

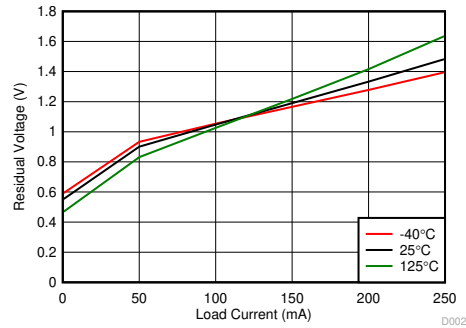

Figure 6-2. Residual Voltage vs Load Current: High Side

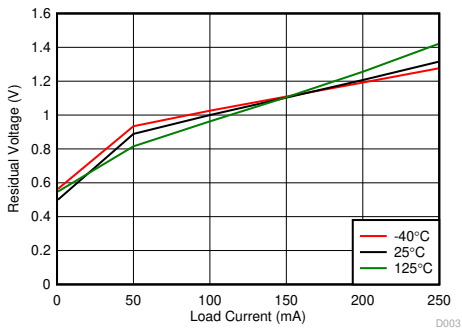

Figure 6-3. Residual Voltage vs Load Current: Low Side

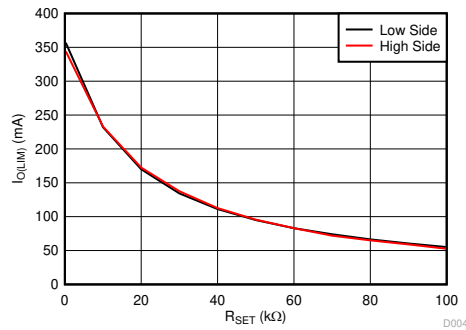

Figure 6-4. Current Limit vs R_{SET}

7 Parameter Measurement Information

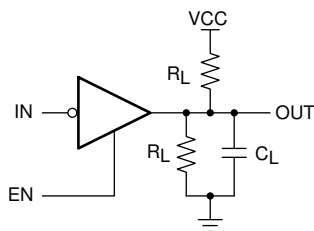

Figure 7-1. Test Circuit for Driver Switching

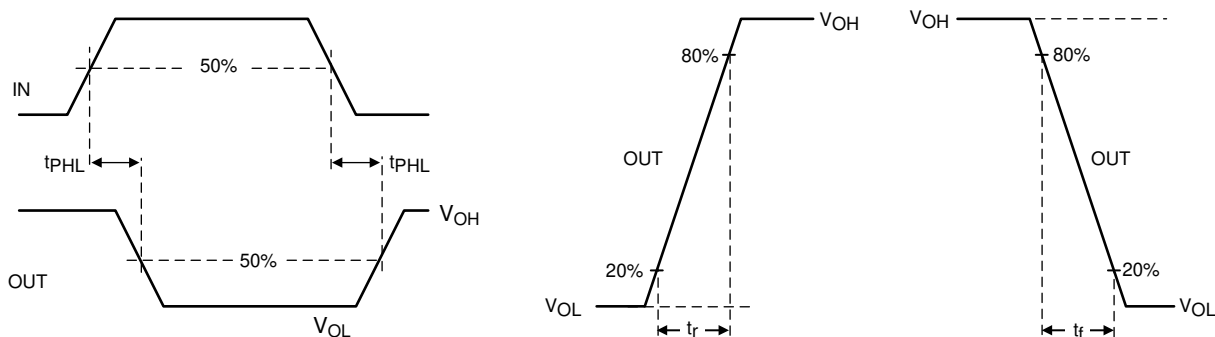

Figure 7-2. Waveforms for Driver Output Switching Measurements

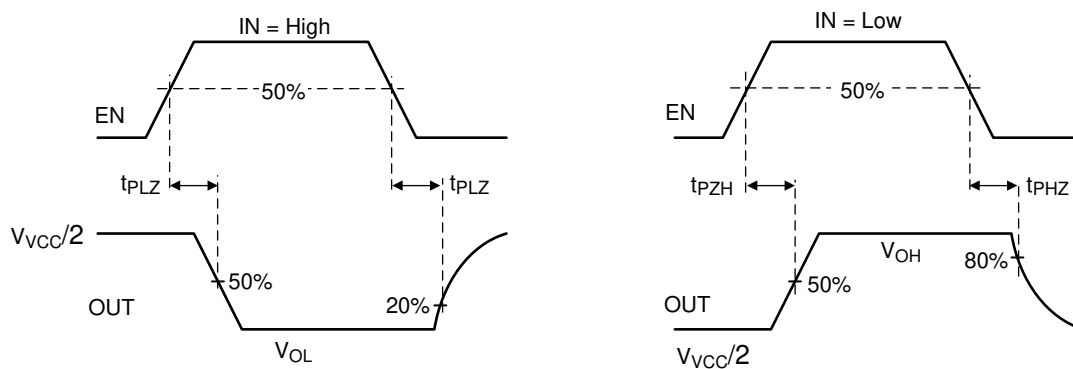

Figure 7-3. Waveforms for Driver Enable or Disable Time Measurements

8 Detailed Description

8.1 Overview

Figure 8-1 shows that the device driver output (OUT) can be used in a push-pull, high-side, or low-side configuration using the enable (EN) and transmit data (IN) input pins. OUT can drive resistive, large capacitive or large inductive loads.

TIOS101 and TIOS101x devices have integrated IEC 61000-4-4/5 EFT and surge protection. In addition, tolerance to $\pm 65\text{-V}$ transients enables flexibility to choose from a wider range of TVS diodes if an application requires higher levels of protection. These integrated robustness features will simplify the system-level design by reducing the external protection circuitry.

These devices implement protection features for over-current, over-voltage and over-temperature conditions. The devices also provide a current-limit setting of the driver output current using an external resistor.

The TIOS101x devices derive the low voltage supply from the typical 24 V industrial supply via an internal linear regulator to provide power to the local controller and sensor circuitry.

8.2 Functional Block Diagrams

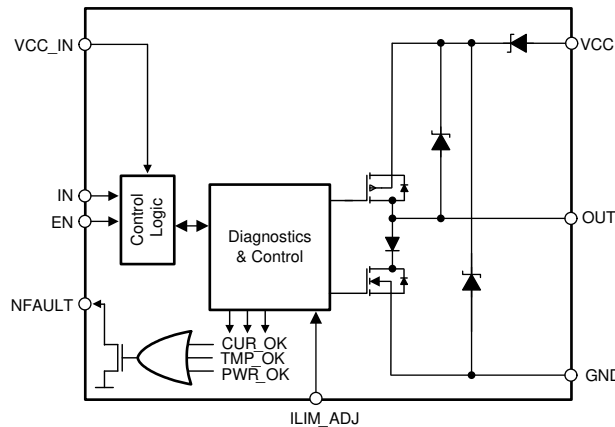

Figure 8-1. Block Diagram, TIOS101

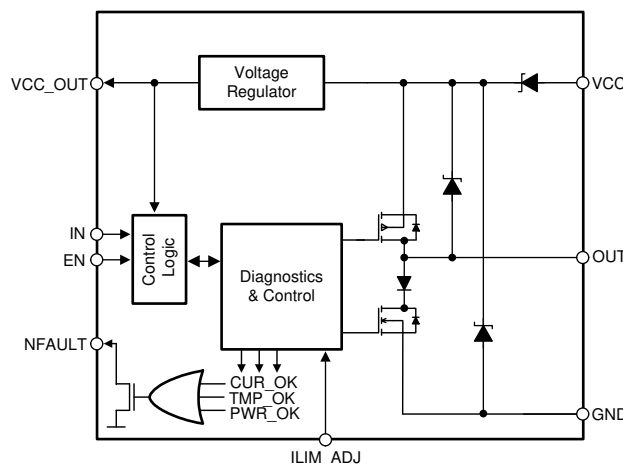

Figure 8-2. Block Diagram, TIOS101x

8.3 Feature Description

8.3.1 Current Limit Configuration

The output current can be configured with an internal resistor on ILIM_ADJ pin. The maximum settable current limit is 300 mA. This maximum setting specifies a minimum of 300 mA over temperature and voltage.

Output disable due to current fault and current fault auto recovery features can be disabled by floating ILIM_ADJ pin. However, the current fault indication is still active in this configuration. This feature is useful when driving large capacitances.

Table 8-1. Current Limitation

ILIM_ADJ Pin Condition	OUT Current Limit	NFAULT Indication During Fault	Output Disable and Auto Recovery
R _{SET} resistor to GND	Variable	Yes	Yes
Connected to GND	300 mA	Yes	Yes
OPEN	300 mA	Yes	No

8.3.2 Current Fault Detection, Indication and Auto Recovery

If the output current at OUT exceeds the internally set current limit $I_{O(LIM)}$ for a duration longer than t_{SC} , the NFAULT pin is driven logic low to indicate a fault condition. The output is turned off, but the LDO continues to function. The output periodically retries to check if the output is still in the over current condition. In this mode, the output is switched on for t_{SC} in t_{SCEN} intervals. Current fault auto recovery mode can be disabled by setting ILIM_ADJ = OPEN. See [Table 8-3](#). Toggling EN will clear NFAULT.

8.3.3 Thermal Warning, Thermal Shutdown

If the die temperature exceeds $T_{(WRN)}$, the NFAULT flag is held low indicating a potential over temperature problem. When the T_J exceeds $T_{(SDN)}$, The output is disabled but the LDO remains operational. As soon as the temperature drops below the temperature threshold (and after $T_{(HYS)}$), the internal circuit re-enables the driver, subject to the state of the EN and IN pins.

8.3.4 Fault Reporting (NFAULT)

NFAULT is driven low if either a current fault condition is detected, die temperature has exceeded $T_{(WRN)}$ or supply has dropped below the UVLO threshold. NFAULT returns to high-impedance as soon as all three fault conditions clear.

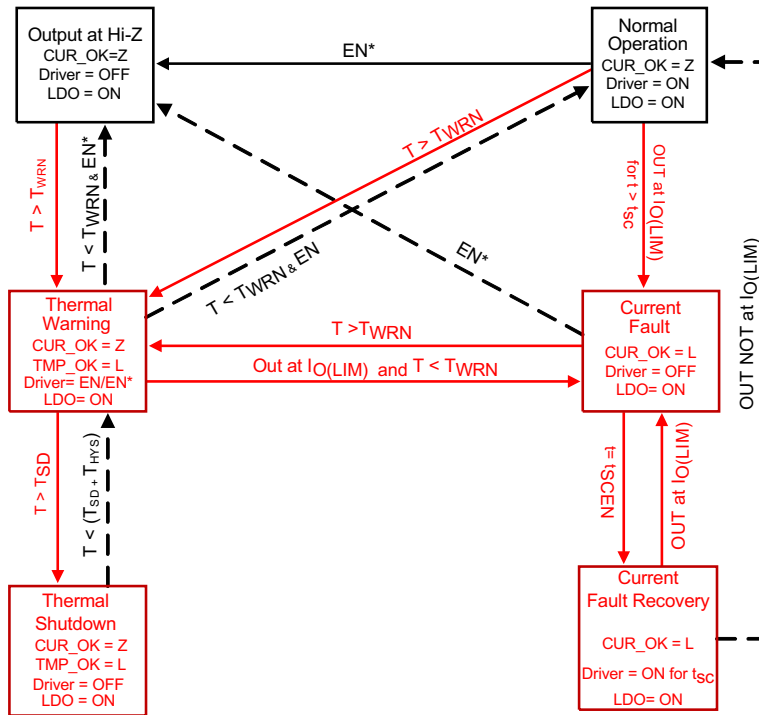

$$NFAULT = [CUR_OK \&\& PWR_OK \&\& TMP_OK]$$

Figure 8-3. Device State Diagram

8.3.5 Device Function Tables

Table 8-2. Driver Function

EN	IN	OUT	COMMENT
L / Open	X	Hi-Z	Device is in ready-to-receive state
H	L	H	OUT is sourcing current (high-side drive)
H	H / Open	L	OUT is sinking current (low-side drive)

Table 8-3. Current Limit Indicator Function ($t > t_{SC}$)

EN	IN	OUT CURRENT	NFAULT	COMMENT
H	H / Open	$ I_{(OUT)} > I_{O(LIM)}$	L	OUT current exceeds the set limit for over t_{SC}
		$ I_{(OUT)} < I_{O(LIM)}$	Z	Normal operation
H	L	$ I_{(OUT)} > I_{O(LIM)}$	L	OUT current exceeds the set limit for over t_{SC}
		$ I_{(OUT)} < I_{O(LIM)}$	Z	Normal operation
L / Open	X	X	Z	Driver is disabled, current limit indicator is inactive

8.3.6 The Integrated Voltage Regulator (LDO)

The TIOS1013 and TIOS1015 each have an integrated linear voltage regulator (LDO) which can supply power to external components. The voltage regulator is specified for VCC voltages in the range of 7 V to 36 V with respect to GND. The LDO is capable of delivering up to 20 mA. The LDO output is current limited to 35-mA to limit the inrush current onto VCC_OUT decoupling capacitors during initial power up.

The LDO is designed to be stable with standard ceramic capacitors with values of 1 μ F or larger at the output. X5R- and X7R-type capacitors are best because they have minimal variation in value and ESR over temperature. Maximum ESR should be less than 1 Ω . With tolerance and dc bias effects, the minimum capacitance to ensure stability is 1 μ F.

8.3.7 Reverse Polarity Protection

Reverse polarity protection circuitry protects the devices against accidental reverse polarity connections to the VCC, OUT and GND pins. The maximum voltage between any of the pins may not exceed 60 V DC at any time.

Figure 8-4 and Figure 8-5 shows all the possible connection combinations.

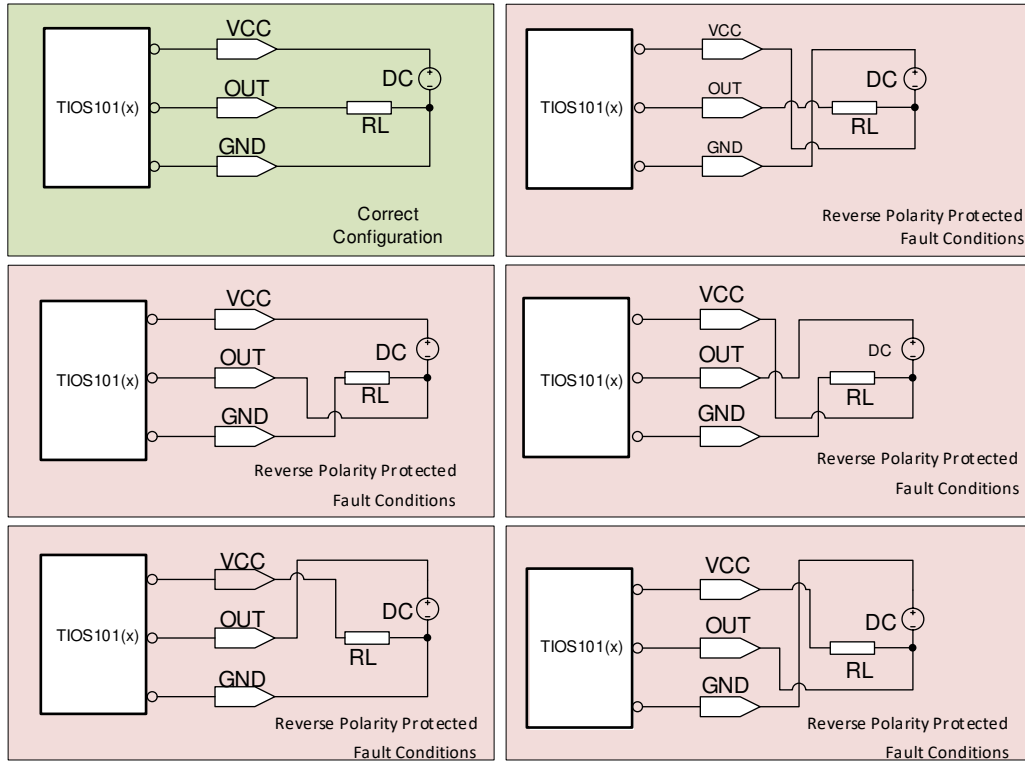

Figure 8-4. High-Side Driver Configuration

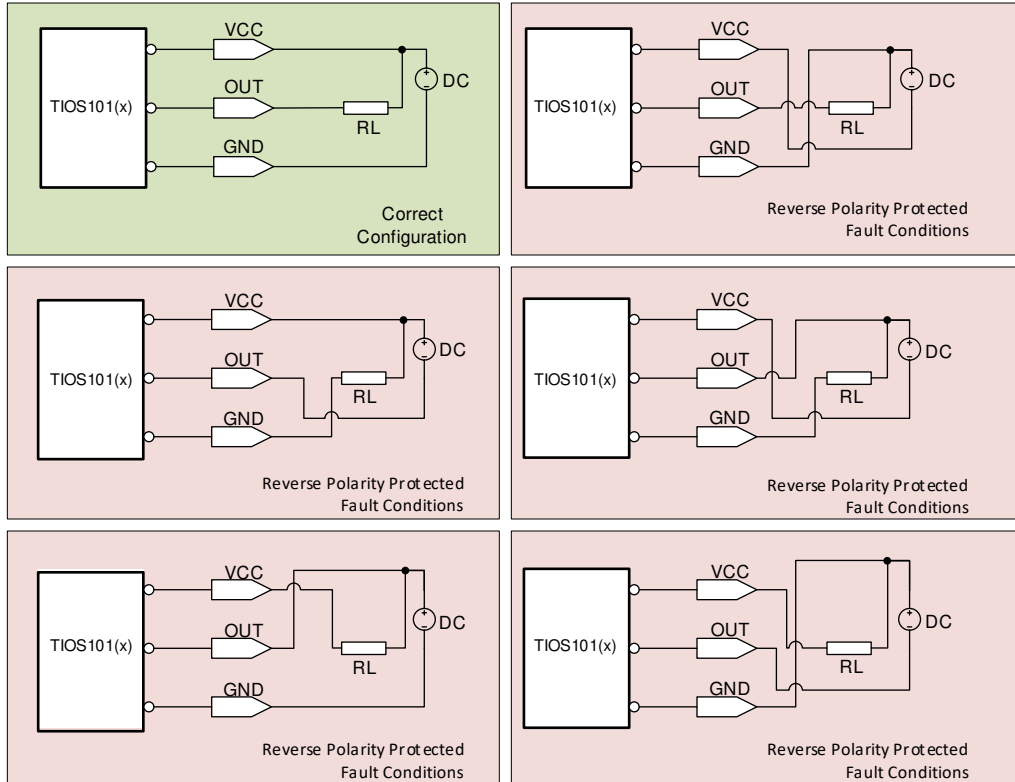
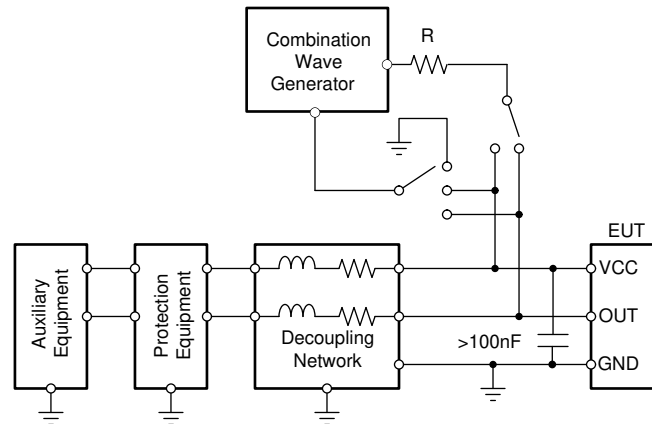

Figure 8-5. Low-Side Driver Configuration

8.3.8 Integrated Surge Protection and Transient Waveform Tolerance

The VCC and OUT pins of the device are capable of withstanding up to 1.2 kV of 1.2/50 – 8/20 μ s IEC 61000-4-5 surge with a source impedance of 500 Ω . The surge testing should be performed with a minimum 100 nF supply decoupling capacitor between VCC and GND, and 1 μ F between VCC_IN/OUT and GND.

External TVS diodes may be required for higher transient protection levels. The system designer should ensure that the maximum clamping voltage of the external diodes should be < 65 V at the desired current level. The device is capable of withstanding up to \pm 65-V transient pulses < 100 μ s.



1.2/50 - 80/20 μ s CWG
R = 500 Ω

Figure 8-6. Surge Test Setup

8.3.9 Power Up Sequence

VCC_IN and VCC domains can be powered up in any sequence. In the event of VCC is powered and VCC_IN is not, the OUT pin remains in high impedance.

8.3.10 Undervoltage Lock-Out (UVLO)

The device enters UVLO if the VCC voltage falls below $V_{(UVLO)}$. (For the device without the integrated LDO, the device monitors VCC_IN in addition to VCC. UVLO happens if either supply falls below the threshold.)

As soon as the supply falls below $V_{(UVLO)}$, NFAULT is pulled low, the LDO is turned off and the OUT output is disabled (Hi-Z). Receiver performance is not specified in this mode.

When the supply rises above $V_{(UVLO)}$, NFAULT returns to Hi-Z (given no other fault conditions present) and the LDO will be enabled immediately. The OUT output will be turned on after $T_{(UVLO)}$ delay.

8.4 Device Functional Modes

These devices can operate in three different modes.

8.4.1 NPN Configuration (N-Switch Mode)

Set IN pin high (or open) and use EN pin as control for realizing the function of an N-switch (low-side configuration) on OUT.

8.4.2 PNP Configuration (P-Switch Mode)

Set IN pin low and use EN pin as control for realizing the function of a P-switch (high-side configuration) on OUT.

8.4.3 Push-Pull Mode

Set EN pin high and toggle IN as control for realizing the function of a push-pull output on OUT. [Table 8-4](#), [Table 8-5](#), and [Table 8-6](#) summarize the pin configurations to accomplish the functional modes.

Table 8-4. NPN Mode

EN	IN	OUT
L / Open	H / Open	Hi-Z
H	H / Open	N-Switch

Table 8-5. PNP Mode

EN	IN	OUT
L / Open	L	Hi-Z
H	L	P-Switch

Table 8-6. Push-Pull Mode

EN	IN	OUT
L / Open	X	Hi-Z
H	H / Open	N-Switch
H	L	P-Switch

9 Application Information Disclaimer

Note

Information in the following applications sections is not part of the TI component specification, and TI does not warrant its accuracy or completeness. TI's customers are responsible for determining suitability of components for their purposes, as well as validating and testing their design implementation to confirm system functionality.

9.1 Application Information

TIOS101 and TIOS101x are robust 24-V digital drivers for industrial sensors.

9.2 Typical Application

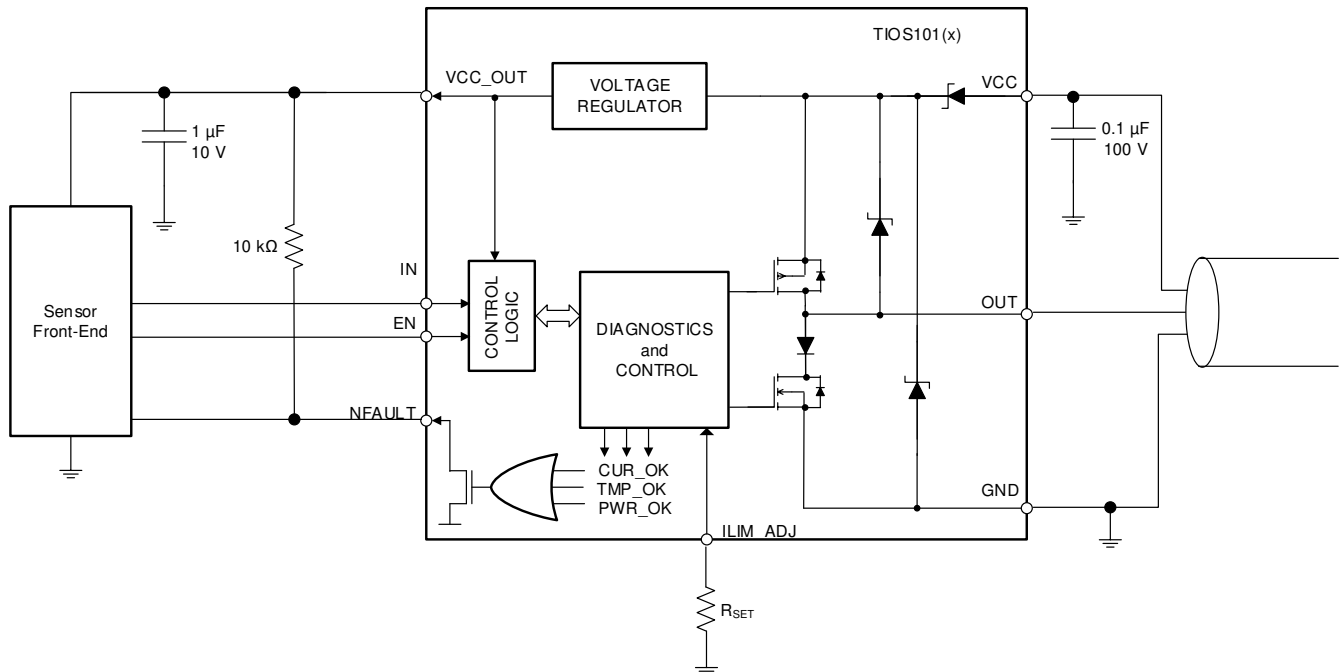

Figure 9-1. Typical Application Schematic

9.2.1 Design Requirements

Table 9-1 shows recommended components for a typical system design.

Table 9-1. Design Parameters

PARAMETERS	VALUE
Input voltage range (VCC)	24 V, 30 V (max)
Output current (OUT)	200 mA
Output voltage (VCC_OUT), Pick TIOS1015	5 V
Maximum LDO output current (I _{VCC(OUT)})	5 mA
Pull-up resistors for NFAULT	10 kΩ
VCC decoupling capacitor	0.1 μF / 100 V
LDO output capacitor	1 μF / 10 V
ILIM_ADJ resistor (R _{SET})	10 kΩ
Maximum Ambient Temperature, T _A	105°C

9.2.2 Detailed Design Procedure

9.2.2.1 Maximum Junction Temperature Check

For a 200 mA current limit:

- The maximum driver output current limit, $I_{O(LIM)} = 250 \text{ mA}$ (allowed for current limit tolerance).
- The maximum voltage drop across the high-side switch is given with $V_{DS(ON)} = 1.75 \text{ V}$.

This causes a power consumption of:

$$PD_{OP} = V_{DS(ON)} \times I_{O(LIM)} = 1.75V \times 250 \text{ mA} = 437.5 \text{ mW} \quad (1)$$

For a 5 mA LDO current output,

$$PD_{LDO} = (V_{L+} - V_{VCC_OUT}) \times I_{VCC_OUT} = (30 - 5)V \times 5 \text{ mA} = 125 \text{ mW} \quad (2)$$

Total power dissipation,

$$PD = PD_{OP} + PD_{LDO} = 437.5 \text{ mW} + 125 \text{ mW} = 562.5 \text{ mW} \quad (3)$$

Multiply this value with the Junction-to-ambient thermal resistance of $\theta_{JA} = 68.1^\circ\text{C/W}$ (taken from the [Section 6.4](#) table) to receive the difference between junction temperature, T_J , and ambient temperature, T_A :

$$\Delta T = T_J - T_A = PD \times \theta_{JA} = 562.5 \text{ mW} \times 68.1^\circ\text{C/W} = 38.3^\circ\text{C} \quad (4)$$

Add this value to the maximum ambient temperature of $T_A = 105^\circ\text{C}$ to receive the final junction temperature:

$$T_{J-max} = T_{A-max} + \Delta T = 105^\circ\text{C} + 38.3^\circ\text{C} = 143.3^\circ\text{C} \quad (5)$$

As long as T_{J-max} is below the recommended maximum value of 150°C , no thermal shutdown will occur. However, thermal warning may occur as the junction temperature is greater than T_{WRN} .

Note that the modeling of the complete system may be necessary to predict junction temperature in smaller PCBs and/or enclosures without air flow.

9.2.2.2 Driving Capacitive Loads

These devices are capable of driving capacitive loads on the OUT output. Assuming a pure capacitive load without series/parallel resistance, the maximum capacitance that can be charged without triggering current fault can be calculated as:

$$C_{LOAD} = \frac{[I_{O(LIM)} \times t_{SC}]}{V_{(VCC)}} \quad (6)$$

Higher capacitive loads can be driven if a series resistor is connected between the OUT and the load. Capacitive loads can be connected to VCC and GND.

9.2.2.3 Driving Inductive Loads

The TIOS101(x) family is capable of magnetizing and demagnetizing inductive loads up to 1.5 H. These devices contain internal circuitry that enables fast demagnetization when configured as either P-switch or N-switch mode.

In P-switch configuration, the load inductor L is magnetized when the OUT pin is driven high. When the PNP is turned off, there is a significant amount of negative inductive kick back at the OUT pin. This voltage is clamped internally at about -75 V.

Similarly in N-switch configuration, the load inductor L is magnetized when the OUT pin is driven low. When the NPN is turned off, there is a significant amount of positive inductive kick back at the OUT pin. This voltage is clamped internally at about 75 V.

The equivalent protection circuits are shown in [Figure 9-2](#) and [Figure 9-3](#). The minimum value of the resistive load R can be calculated as:

$$R = \frac{V_{(VCC)}}{I_{O(LIM)}} \tag{7}$$

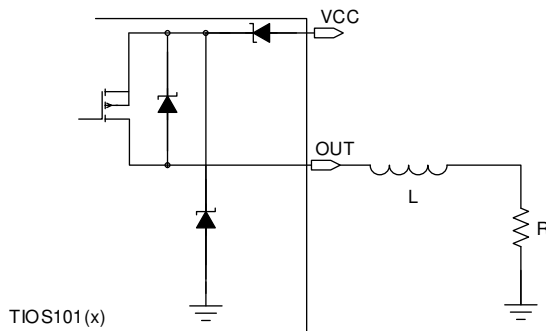

Figure 9-2. PNP Mode

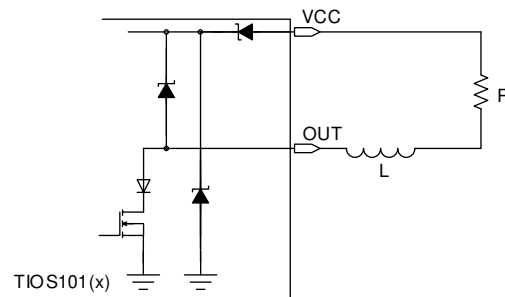
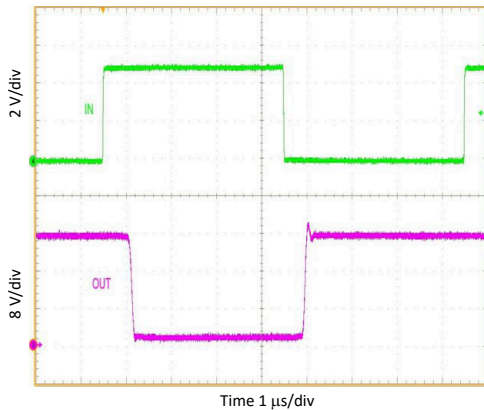

Figure 9-3. NPN Mode

9.2.3 Application Curves



125 kHz

Figure 9-4. OUT in Push-Pull Mode

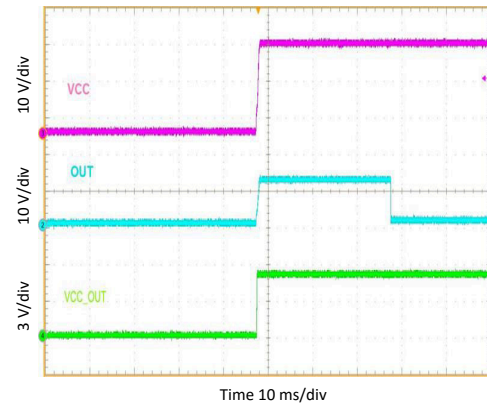

Figure 9-5. OUT Power Up Delay, Low Side Mode

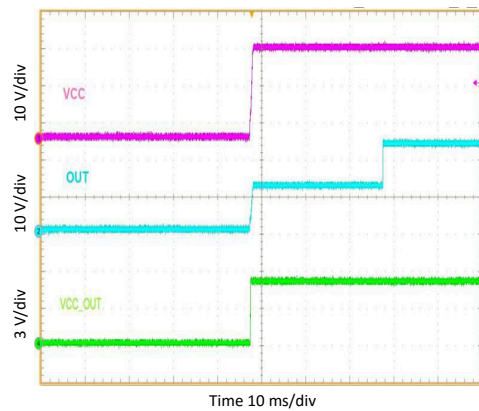

Figure 9-6. OUT Power Up Delay, High Side Mode

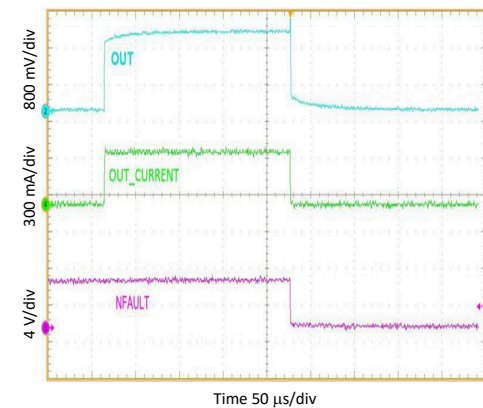

Figure 9-7. OUT In Current Fault, Low Side Mode

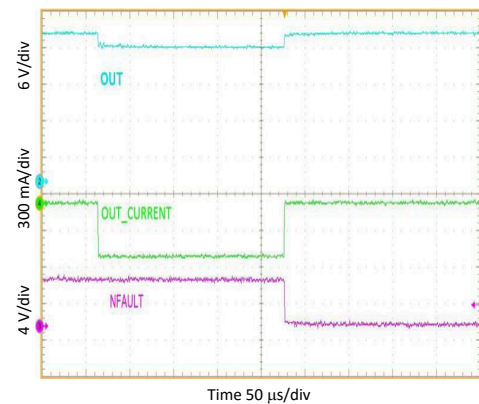

Figure 9-8. OUT In Current Fault, High Side Mode

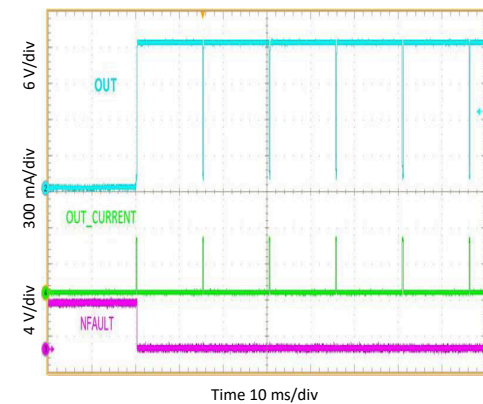

Figure 9-9. OUT In Current Fault Auto Recovery, Low Side Mode

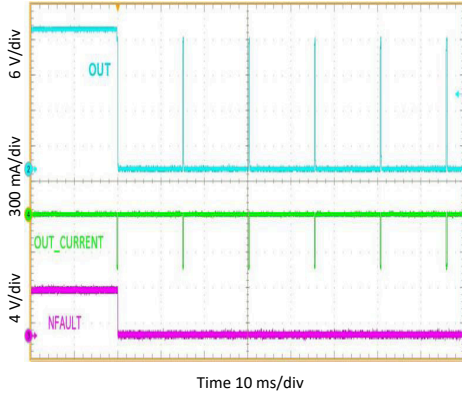
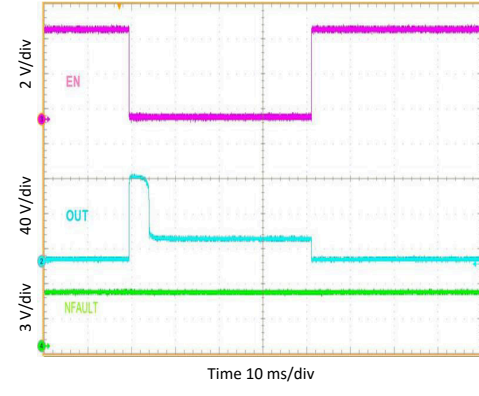
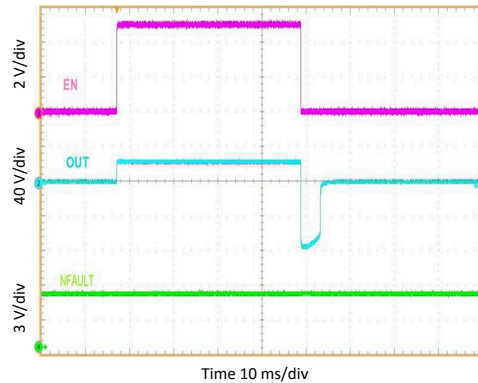

Figure 9-10. OUT In Current Fault Auto Recovery, High Side Mode



1.5-H Inductor With = 100 Ω R_{SET} = OPEN

Figure 9-11. OUT Driving, Low Side Mode



1.5-H Inductor With = 100 Ω R_{SET} = OPEN

Figure 9-12. OUT Driving, High Side Mode

10 Power Supply Recommendations

The TIOS101 and TIOS101x are designed to operate from a 24-V nominal supply at VCC, which can vary by +12 V and -17 V from the nominal value to remain within the device's recommended supply voltage range of 7 V to 36 V. This supply should be buffered with at least a 100-nF/100-V capacitor.

11 Layout

11.1 Layout Guidelines

- Use of a 4-layer board is recommended for good heat conduction. Use layer 1 (top layer) for control signals, layer 2 as GND, layer 3 for the 24-V supply plane (VCC), and layer 4 for the regulated output supply (VCC_IN/OUT).
- Connect the thermal pad to GND with maximum amount of thermal vias for best thermal performance.
- Use entire planes for VCC, VCC_IN/OUT and GND to assure minimum inductance.
- The VCC terminal must be decoupled to ground with a low-ESR ceramic decoupling capacitor with a minimum value of 100 nF. The capacitor must have a voltage rating of 50 V minimum (100 V depending on max sensor supply fault rating) and an X5R or X7R dielectric.
- The optimum placement of the capacitor is closest to the VCC and GND terminals to reduce supply drops during large supply current loads. See [Figure 11-1](#) for a PCB layout example.
- Connect all open-drain control outputs via 10 kΩ pull-up resistors to the VCC_IN/OUT plane to provide a defined voltage potential to the system controller inputs when the outputs are high-impedance.
- Connect the R_{SET} resistor between ILIM_ADJ and GND.
- Decouple the regulated output voltage at VCC_IN/OUT to ground with a low-ESR, 1 μF, ceramic decoupling capacitor. The capacitor should have a voltage rating of 10 V minimum and an X5R or X7R dielectric.

11.2 Layout Example

- VIA to Layer 2: Power Ground Plane (VCC)
- VIA to Layer 3: 24V Supply Plane (GND)
- VIA to Layer 4: Regulated Supply Plane (VCC_IN/OUT)

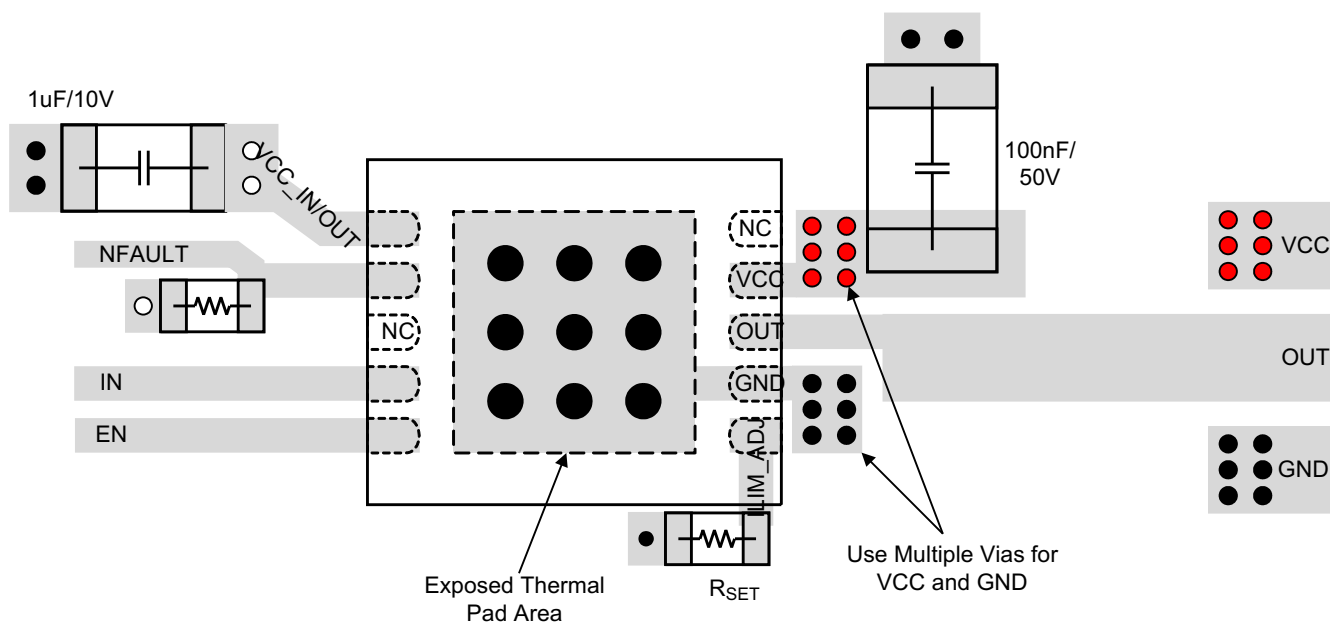

Figure 11-1. Layout Example

12 Device and Documentation Support

12.1 Receiving Notification of Documentation Updates

To receive notification of documentation updates, navigate to the device product folder on ti.com. Click on *Subscribe to updates* to register and receive a weekly digest of any product information that has changed. For change details, review the revision history included in any revised document.

12.2 Support Resources

[TI E2E™ support forums](#) are an engineer's go-to source for fast, verified answers and design help — straight from the experts. Search existing answers or ask your own question to get the quick design help you need.

Linked content is provided "AS IS" by the respective contributors. They do not constitute TI specifications and do not necessarily reflect TI's views; see TI's [Terms of Use](#).

12.3 Trademarks

TI E2E™ is a trademark of Texas Instruments.
All trademarks are the property of their respective owners.

12.4 Electrostatic Discharge Caution



This integrated circuit can be damaged by ESD. Texas Instruments recommends that all integrated circuits be handled with appropriate precautions. Failure to observe proper handling and installation procedures can cause damage.

ESD damage can range from subtle performance degradation to complete device failure. Precision integrated circuits may be more susceptible to damage because very small parametric changes could cause the device not to meet its published specifications.

12.5 Glossary

[TI Glossary](#) This glossary lists and explains terms, acronyms, and definitions.

Mechanical, Packaging, and Orderable Information

The following pages include mechanical, packaging, and orderable information. This information is the most current data available for the designated devices. This data is subject to change without notice and revision of this document. For browser-based versions of this data sheet, refer to the left-hand navigation.

PACKAGING INFORMATION

Orderable Device	Status (1)	Package Type	Package Drawing	Pins	Package Qty	Eco Plan (2)	Lead finish/ Ball material (6)	MSL Peak Temp (3)	Op Temp (°C)	Device Marking (4/5)	Samples
TIOS1013DMWR	ACTIVE	VSON	DMW	10	1500	RoHS & Green	NIPDAU	Level-2-260C-1 YEAR	-40 to 125	TS1013	Samples
TIOS1013DMWT	ACTIVE	VSON	DMW	10	250	RoHS & Green	NIPDAU	Level-2-260C-1 YEAR	-40 to 125	TS1013	Samples
TIOS1015DMWR	ACTIVE	VSON	DMW	10	1500	RoHS & Green	NIPDAU	Level-2-260C-1 YEAR	-40 to 125	TS1015	Samples
TIOS1015DMWT	ACTIVE	VSON	DMW	10	250	RoHS & Green	NIPDAU	Level-2-260C-1 YEAR	-40 to 125	TS1015	Samples
TIOS101DMWR	ACTIVE	VSON	DMW	10	1500	RoHS & Green	NIPDAU	Level-2-260C-1 YEAR	-40 to 125	TS101	Samples
TIOS101DMWT	ACTIVE	VSON	DMW	10	250	RoHS & Green	NIPDAU	Level-2-260C-1 YEAR	-40 to 125	TS101	Samples

(1) The marketing status values are defined as follows:

ACTIVE: Product device recommended for new designs.

LIFEBUY: TI has announced that the device will be discontinued, and a lifetime-buy period is in effect.

NRND: Not recommended for new designs. Device is in production to support existing customers, but TI does not recommend using this part in a new design.

PREVIEW: Device has been announced but is not in production. Samples may or may not be available.

OBSOLETE: TI has discontinued the production of the device.

(2) **RoHS:** TI defines "RoHS" to mean semiconductor products that are compliant with the current EU RoHS requirements for all 10 RoHS substances, including the requirement that RoHS substance do not exceed 0.1% by weight in homogeneous materials. Where designed to be soldered at high temperatures, "RoHS" products are suitable for use in specified lead-free processes. TI may reference these types of products as "Pb-Free".

RoHS Exempt: TI defines "RoHS Exempt" to mean products that contain lead but are compliant with EU RoHS pursuant to a specific EU RoHS exemption.

Green: TI defines "Green" to mean the content of Chlorine (Cl) and Bromine (Br) based flame retardants meet JS709B low halogen requirements of <=1000ppm threshold. Antimony trioxide based flame retardants must also meet the <=1000ppm threshold requirement.

(3) MSL, Peak Temp. - The Moisture Sensitivity Level rating according to the JEDEC industry standard classifications, and peak solder temperature.

(4) There may be additional marking, which relates to the logo, the lot trace code information, or the environmental category on the device.

(5) Multiple Device Markings will be inside parentheses. Only one Device Marking contained in parentheses and separated by a "~" will appear on a device. If a line is indented then it is a continuation of the previous line and the two combined represent the entire Device Marking for that device.

(6) Lead finish/Ball material - Orderable Devices may have multiple material finish options. Finish options are separated by a vertical ruled line. Lead finish/Ball material values may wrap to two lines if the finish value exceeds the maximum column width.

Important Information and Disclaimer: The information provided on this page represents TI's knowledge and belief as of the date that it is provided. TI bases its knowledge and belief on information provided by third parties, and makes no representation or warranty as to the accuracy of such information. Efforts are underway to better integrate information from third parties. TI has taken and continues to take reasonable steps to provide representative and accurate information but may not have conducted destructive testing or chemical analysis on incoming materials and chemicals. TI and TI suppliers consider certain information to be proprietary, and thus CAS numbers and other limited information may not be available for release.

In no event shall TI's liability arising out of such information exceed the total purchase price of the TI part(s) at issue in this document sold by TI to Customer on an annual basis.

TAPE AND REEL INFORMATION

QUADRANT ASSIGNMENTS FOR PIN 1 ORIENTATION IN TAPE



*All dimensions are nominal

Device	Package Type	Package Drawing	Pins	SPQ	Reel Diameter (mm)	Reel Width W1 (mm)	A0 (mm)	B0 (mm)	K0 (mm)	P1 (mm)	W (mm)	Pin1 Quadrant
TIOS1013DMWR	VSON	DMW	10	1500	178.0	13.5	2.75	3.35	1.05	8.0	12.0	Q2
TIOS1013DMWT	VSON	DMW	10	250	178.0	13.5	2.75	3.35	1.05	8.0	12.0	Q2
TIOS1015DMWR	VSON	DMW	10	1500	178.0	13.5	2.75	3.35	1.05	8.0	12.0	Q2
TIOS1015DMWT	VSON	DMW	10	250	178.0	13.5	2.75	3.35	1.05	8.0	12.0	Q2
TIOS101DMWR	VSON	DMW	10	1500	178.0	13.5	2.75	3.35	1.05	8.0	12.0	Q2
TIOS101DMWT	VSON	DMW	10	250	178.0	13.5	2.75	3.35	1.05	8.0	12.0	Q2

TAPE AND REEL BOX DIMENSIONS

*All dimensions are nominal

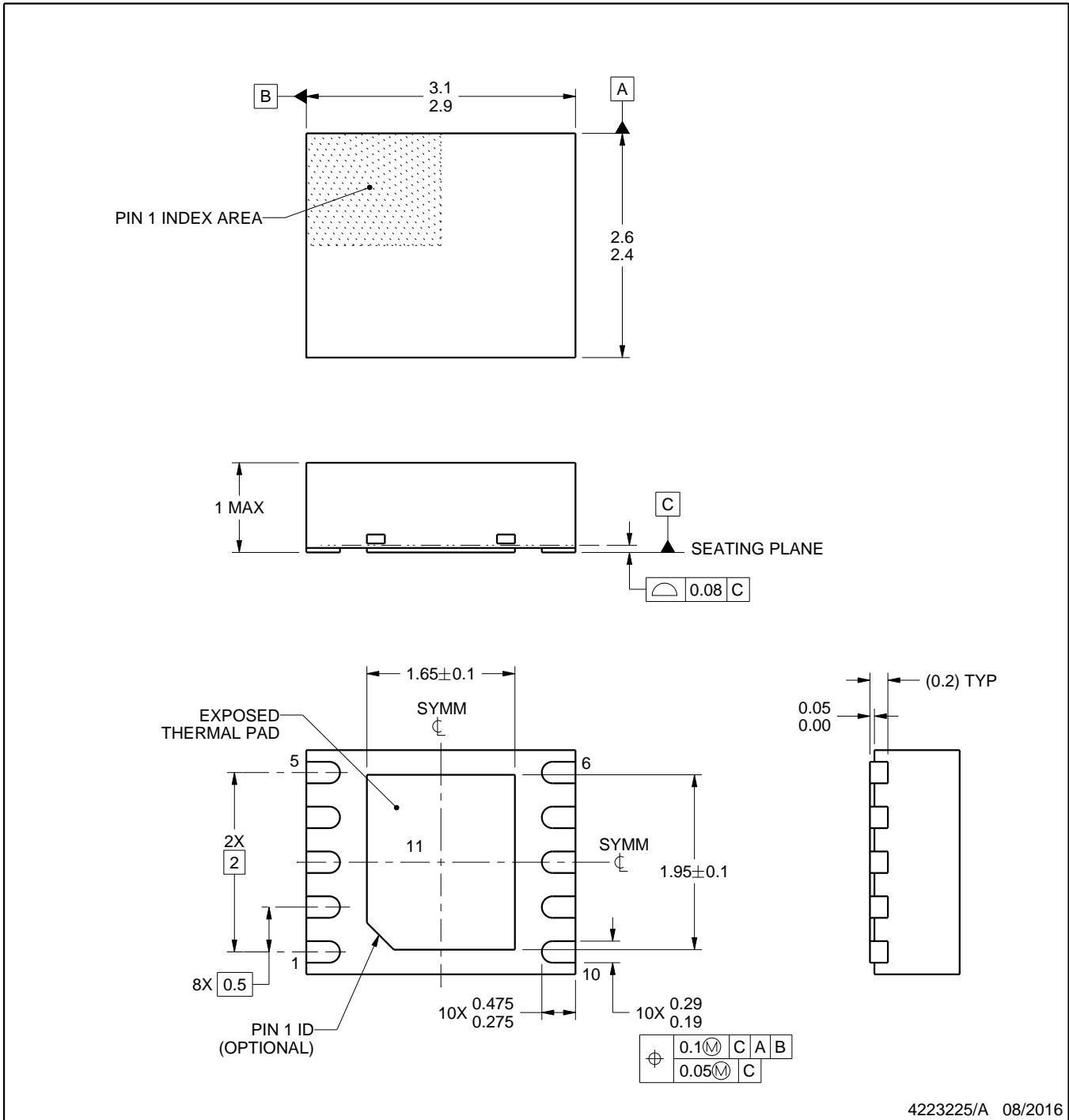
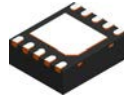
Device	Package Type	Package Drawing	Pins	SPQ	Length (mm)	Width (mm)	Height (mm)
TIOS1013DMWR	VSON	DMW	10	1500	189.0	185.0	36.0
TIOS1013DMWT	VSON	DMW	10	250	189.0	185.0	36.0
TIOS1015DMWR	VSON	DMW	10	1500	189.0	185.0	36.0
TIOS1015DMWT	VSON	DMW	10	250	189.0	185.0	36.0
TIOS101DMWR	VSON	DMW	10	1500	189.0	185.0	36.0
TIOS101DMWT	VSON	DMW	10	250	189.0	185.0	36.0



NOTES:

1. All linear dimensions are in millimeters. Any dimensions in parenthesis are for reference only. Dimensioning and tolerancing per ASME Y14.5M.
2. This drawing is subject to change without notice.
3. The package thermal pad must be soldered to the printed circuit board for thermal and mechanical performance.

EXAMPLE BOARD LAYOUT

DMW0010A

VSON - 1 mm max height

PLASTIC SMALL OUTLINE - NO LEAD

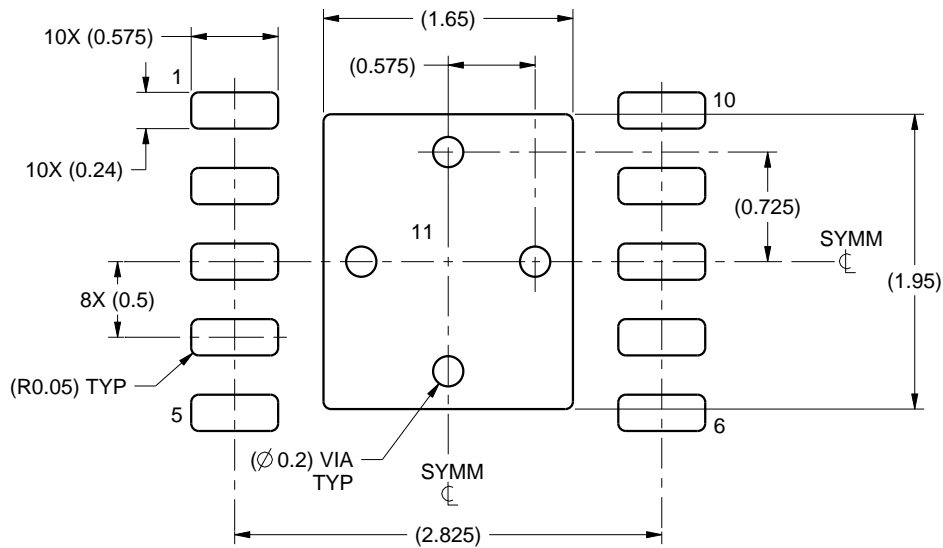

LAND PATTERN EXAMPLE
SCALE:20X

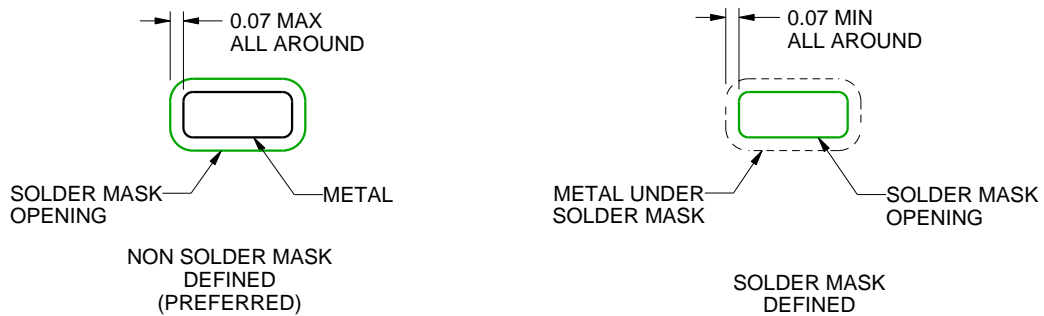

SOLDER MASK DETAILS

4223225/A 08/2016

NOTES: (continued)

4. This package is designed to be soldered to a thermal pad on the board. For more information, see Texas Instruments literature number SLUA271 (www.ti.com/lit/sluea271).
5. Vias are optional depending on application, refer to device data sheet. If any vias are implemented, refer to their locations shown on this view. It is recommended that vias under paste be filled, plugged or tented.

EXAMPLE STENCIL DESIGN

DMW0010A

VSON - 1 mm max height

PLASTIC SMALL OUTLINE - NO LEAD

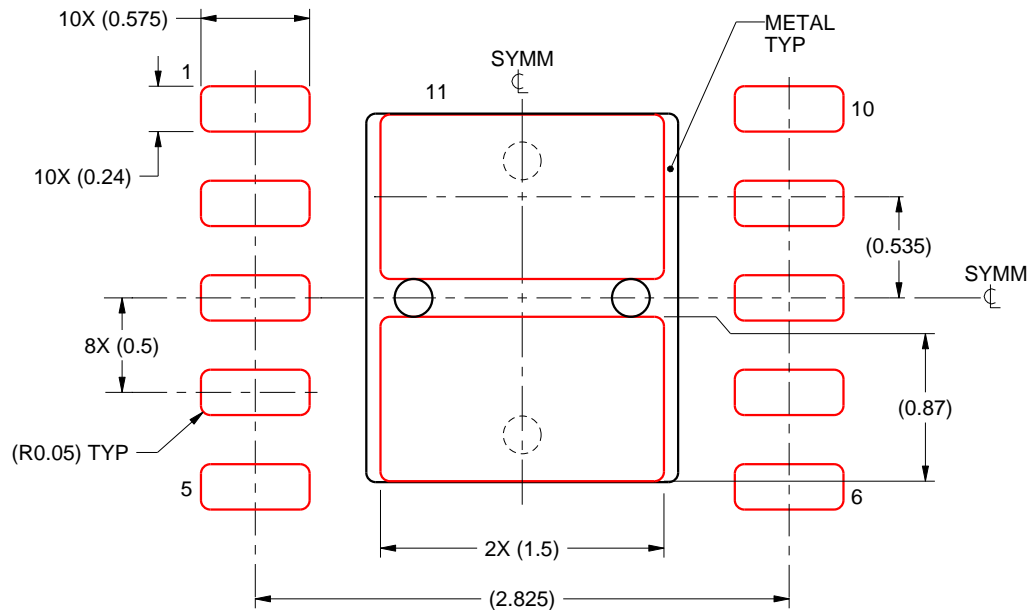

SOLDER PASTE EXAMPLE
BASED ON 0.125 mm THICK STENCIL

EXPOSED PAD 11
81% PRINTED SOLDER COVERAGE BY AREA UNDER PACKAGE
SCALE:25X

4223225/A 08/2016

NOTES: (continued)

6. Laser cutting apertures with trapezoidal walls and rounded corners may offer better paste release. IPC-7525 may have alternate design recommendations.

IMPORTANT NOTICE AND DISCLAIMER

TI PROVIDES TECHNICAL AND RELIABILITY DATA (INCLUDING DATA SHEETS), DESIGN RESOURCES (INCLUDING REFERENCE DESIGNS), APPLICATION OR OTHER DESIGN ADVICE, WEB TOOLS, SAFETY INFORMATION, AND OTHER RESOURCES "AS IS" AND WITH ALL FAULTS, AND DISCLAIMS ALL WARRANTIES, EXPRESS AND IMPLIED, INCLUDING WITHOUT LIMITATION ANY IMPLIED WARRANTIES OF MERCHANTABILITY, FITNESS FOR A PARTICULAR PURPOSE OR NON-INFRINGEMENT OF THIRD PARTY INTELLECTUAL PROPERTY RIGHTS.

These resources are intended for skilled developers designing with TI products. You are solely responsible for (1) selecting the appropriate TI products for your application, (2) designing, validating and testing your application, and (3) ensuring your application meets applicable standards, and any other safety, security, regulatory or other requirements.

These resources are subject to change without notice. TI grants you permission to use these resources only for development of an application that uses the TI products described in the resource. Other reproduction and display of these resources is prohibited. No license is granted to any other TI intellectual property right or to any third party intellectual property right. TI disclaims responsibility for, and you will fully indemnify TI and its representatives against, any claims, damages, costs, losses, and liabilities arising out of your use of these resources.

TI's products are provided subject to [TI's Terms of Sale](#) or other applicable terms available either on [ti.com](https://www.ti.com) or provided in conjunction with such TI products. TI's provision of these resources does not expand or otherwise alter TI's applicable warranties or warranty disclaimers for TI products.

TI objects to and rejects any additional or different terms you may have proposed.

Mailing Address: Texas Instruments, Post Office Box 655303, Dallas, Texas 75265
Copyright © 2023, Texas Instruments Incorporated

Looking for pricing, stock, or lifecycle information?

Click below to explore more details on WIN SOURCE:

 [View TIOS101DMWT on WIN SOURCE](#)

 [Texas Instruments](#) Information

Optimize Your Supply Chain with WIN SOURCE Solutions

-  Global Sourcing Solution
-  Obsolete Management
-  Cost Control Management
-  Shortage Management
-  Alternative Solution
-  Excess Inventory Management