



**THE DATASHEET OF
RMLV0808BGSB-4S2#AA0**



RMLV0808BGSB - 4S2

8Mb Advanced LPSRAM (1024k word × 8bit)

R10DS0232EJ0201
Rev.2.01
2020.02.20

Description

The RMLV0808BGSB is a family of 8-Mbit static RAMs organized 1,048,576-word × 8-bit, fabricated by Renesas's high-performance Advanced LPSRAM technologies. The RMLV0808BGSB has realized higher density, higher performance and low power consumption. The RMLV0808BGSB offers low power standby power dissipation; therefore, it is suitable for battery backup systems. It is offered in 44pin TSOP (II).

Features

- Single 3V supply: 2.4V to 3.6V
- Access time:
 - Power supply voltage from 2.7V to 3.6V: 45ns (max.)
 - Power supply voltage from 2.4V to 2.7V: 55ns (max.)
- Current consumption:
 - Standby: 0.45μA (typ.)
- Equal access and cycle times
- Common data input and output
 - Three state output
- Directly TTL compatible
 - All inputs and outputs
- Battery backup operation

Part Name Information

Part Name	Power supply	Access time	Temperature Range	Package
RMLV0808BGSB-4S2	2.7V to 3.6V	45 ns	-40 ~ +85°C	11.76mm×18.41mm 44pin plastic TSOP(II)
	2.4V to 2.7V	55 ns		

Block Diagram

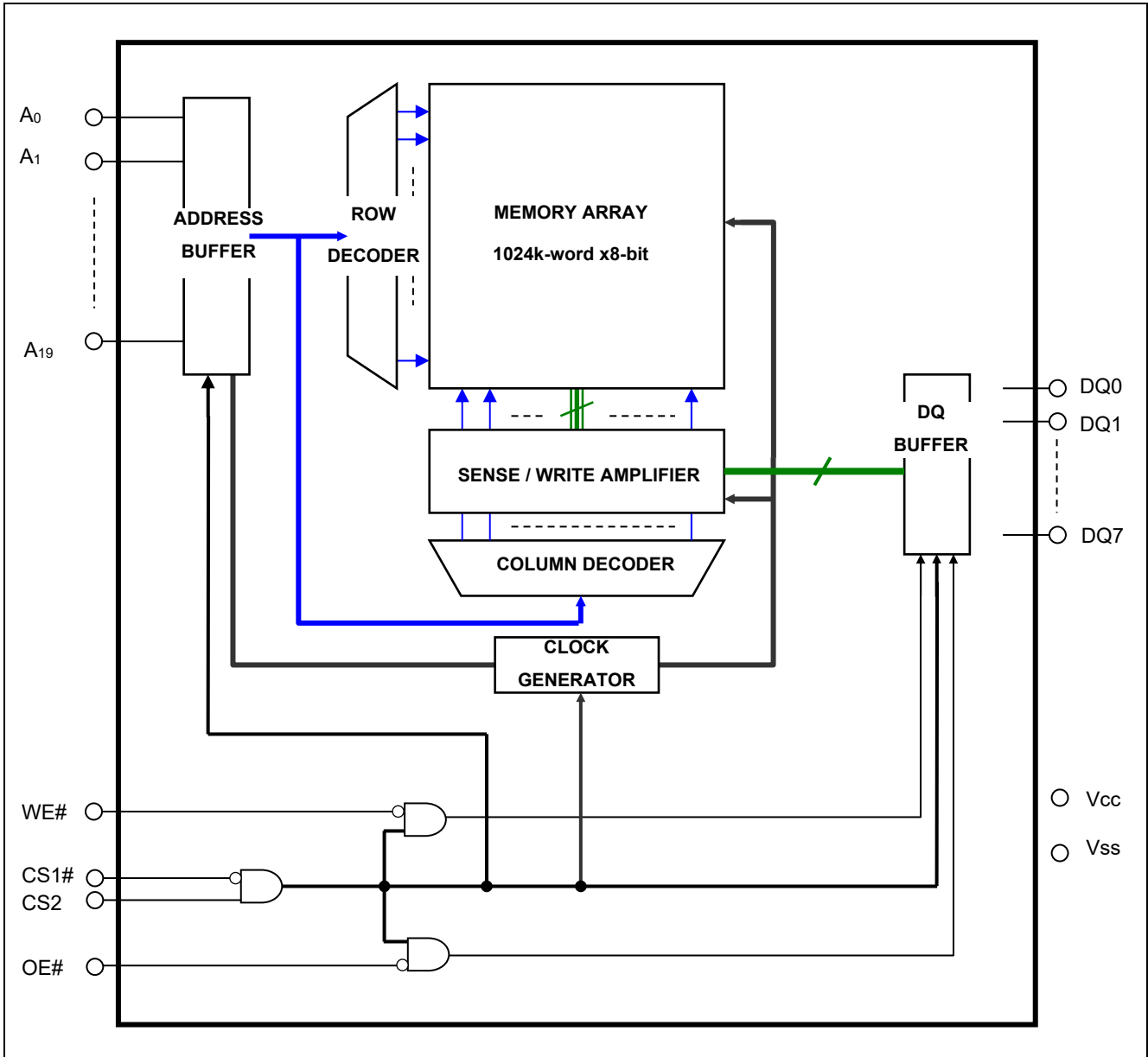

Operation Table

CS1#	CS2	WE#	OE#	DQ0~7	Operation
H	X	X	X	High-Z	Stand-by
X	L	X	X	High-Z	Stand-by
L	H	L	X	Din	Write
L	H	H	L	Dout	Read
L	H	H	H	High-Z	Output disable

Note 1. H: V_{IH} L: V_{IL} X: V_{IH} or V_{IL}

Absolute Maximum Ratings

Parameter	Symbol	Value	unit
Power supply voltage relative to V _{SS}	V _{CC}	-0.5 to +4.6	V
Terminal voltage on any pin relative to V _{SS}	V _T	-0.5 ² to V _{CC} +0.3 ³	V
Power dissipation	P _T	0.7	W
Operation temperature	T _{opr}	-40 to +85	°C
Storage temperature range	T _{stg}	-65 to +150	°C
Storage temperature range under bias	T _{bias}	-40 to +85	°C

Note 2. -3.0V for pulse ≤ 30ns (full width at half maximum)

3. Maximum voltage is +4.6V.

DC Operating Conditions

Parameter	Symbol	Min.	Typ.	Max.	Unit	Test conditions	Note
Supply voltage	V _{CC}	2.4	3.0	3.6	V		
	V _{SS}	0	0	0	V		
Input high voltage	V _{IH}	2.0	—	V _{CC} +0.2	V	V _{CC} =2.4V to 2.7V	
		2.2	—	V _{CC} +0.2	V	V _{CC} =2.7V to 3.6V	
Input low voltage	V _{IL}	-0.2	—	0.4	V	V _{CC} =2.4V to 2.7V	4
		-0.2	—	0.6	V	V _{CC} =2.7V to 3.6V	4
Ambient temperature range	T _a	-40	—	+85	°C		

Note 4. -3.0V for pulse ≤ 30ns (full width at half maximum)

DC Characteristics

Parameter	Symbol	Min.	Typ.	Max.	Unit	Test conditions	
Input leakage current	I _{LI}	—	—	1	μA	V _{in} = V _{SS} to V _{CC}	
Output leakage current	I _{LO}	—	—	1	μA	CS1# = V _{IH} or CS2 = V _{IL} or OE# = V _{IH} or WE# = V _{IL} , V _{I/O} = V _{SS} to V _{CC}	
Average operating current	I _{CC1}	—	20 ^{*5}	25	mA	Cycle = 55ns, duty = 100%, I _{I/O} = 0mA, CS1# = V _{IL} , CS2 = V _{IH} , Others = V _{IH} /V _{IL}	
		—	25 ^{*5}	30	mA	Cycle = 45ns, duty = 100%, I _{I/O} = 0mA, CS1# = V _{IL} , CS2 = V _{IH} , Others = V _{IH} /V _{IL}	
	I _{CC2}	—	1.5 ^{*5}	3	mA	Cycle = 1μs, duty = 100%, I _{I/O} = 0mA, CS1# ≤ 0.2V, CS2 ≥ V _{CC} -0.2V, V _{IH} ≥ V _{CC} -0.2V, V _{IL} ≤ 0.2V	
Standby current	I _{SB}	—	—	0.3	mA	CS2 = V _{IL} , Others = V _{SS} to V _{CC}	
Standby current	I _{SB1}	—	0.45 ^{*5}	2	μA	~+25°C	V _{in} = V _{SS} to V _{CC} , (1) CS2 ≤ 0.2V or (2) CS1# ≥ V _{CC} -0.2V, CS2 ≥ V _{CC} -0.2V
		—	0.6 ^{*6}	4	μA	~+40°C	
		—	—	7	μA	~+70°C	
		—	—	10	μA	~+85°C	
Output high voltage	V _{OH}	2.4	—	—	V	I _{OH} = -1mA V _{CC} ≥ 2.7V	
	V _{OH2}	2.0	—	—	V	I _{OH} = -0.1mA	
Output low voltage	V _{OL}	—	—	0.4	V	I _{OL} = 2mA V _{CC} ≥ 2.7V	
	V _{OL2}	—	—	0.4	V	I _{OL} = 0.1mA	

Note 5. Typical parameter indicates the value for the center of distribution at 3.0V (T_a=25°C), and not 100% tested.

Note 6. Typical parameter indicates the value for the center of distribution at 3.0V (T_a=40°C), and not 100% tested.

Capacitance

(Ta =25°C, f =1MHz)

Parameter	Symbol	Min.	Typ.	Max.	Unit	Test conditions	Note
Input capacitance	C _{in}	—	—	8	pF	V _{in} =0V	7
Input / output capacitance	C _{I/O}	—	—	10	pF	V _{I/O} =0V	7

Note 7. This parameter is sampled and not 100% tested.

AC Characteristics

Test Conditions (V_{cc} = 2.4V ~ 3.6V, Ta = -40 ~ +85°C)

- Input pulse levels:
 - V_{IL} = 0.4V, V_{IH} = 2.4V (V_{cc}=2.7V to 3.6V)
 - V_{IL} = 0.4V, V_{IH} = 2.2V (V_{cc}=2.4V to 2.7V)
- Input rise and fall time: 5ns
- Input and output timing reference level: 1.4V
- Output load: See figures (Including scope and jig)

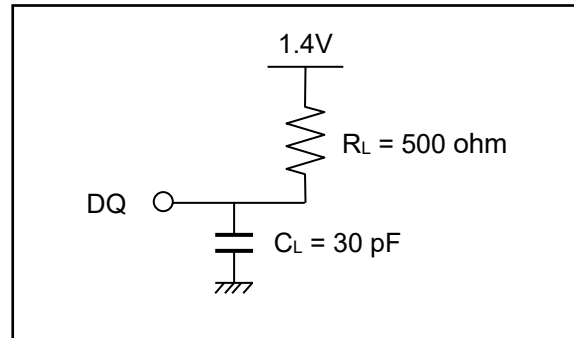

Read Cycle

Parameter	Symbol	V _{cc} =2.7V to 3.6V		V _{cc} =2.4V to 2.7V		Unit	Note
		Min.	Max.	Min.	Max.		
Read cycle time	t _{RC}	45	—	55	—	ns	
Address access time	t _{AA}	—	45	—	55	ns	
Chip select access time	t _{ACS1}	—	45	—	55	ns	
	t _{ACS2}	—	45	—	55	ns	
Output enable to output valid	t _{OE}	—	22	—	30	ns	
Output hold from address change	t _{OH}	10	—	10	—	ns	
Chip select to output in low-Z	t _{CLZ1}	10	—	10	—	ns	8,9
	t _{CLZ2}	10	—	10	—	ns	8,9
Output enable to output in low-Z	t _{OLZ}	5	—	5	—	ns	8,9
Chip deselect to output in high-Z	t _{CHZ1}	0	18	0	20	ns	8,9,10
	t _{CHZ2}	0	18	0	20	ns	8,9,10
Output disable to output in high-Z	t _{OHZ}	0	18	0	20	ns	8,9,10

Note 8. This parameter is sampled and not 100% tested.

- At any given temperature and voltage condition, t_{CHZ1} max is less than t_{CLZ1} min, t_{CHZ2} max is less than t_{CLZ2} min, and t_{OHZ} max is less than t_{OLZ} min, for any device.
- t_{CHZ1}, t_{CHZ2} and t_{OHZ} are defined as the time when the DQ pins enter a high-impedance state and are not referred to the DQ levels.

Write Cycle

Parameter	Symbol	Vcc=2.7V to 3.6V		Vcc=2.4V to 2.7V		Unit	Note
		Min.	Max.	Min.	Max.		
Write cycle time	t _{WC}	45	—	55	—	ns	
Address valid to write end	t _{AW}	35	—	50	—	ns	
Chip select to write end	t _{CW}	35	—	50	—	ns	
Write pulse width	t _{WP}	35	—	40	—	ns	11
Address setup time to write start	t _{AS}	0	—	0	—	ns	
Write recovery time from write end	t _{WR}	0	—	0	—	ns	
Data to write time overlap	t _{DW}	25	—	25	—	ns	
Data hold from write end	t _{DH}	0	—	0	—	ns	
Output enable from write end	t _{OW}	5	—	5	—	ns	12
Output disable to output in high-Z	t _{OHZ}	0	18	0	20	ns	12,13
Write to output in high-Z	t _{WHZ}	0	18	0	20	ns	12,13

Note 11. t_{WP} is the interval between write start and write end.

A write starts when all of (CS1#), (WE#) and (CS2) become active.

A write is performed during the overlap of a low CS1#, a low WE# and a high CS2.

A write ends when any of (CS1#), (WE#) or (CS2) becomes inactive.

12. This parameter is sampled and not 100% tested.

13. t_{OHZ} and t_{WHZ} are defined as the time when the DQ pins enter a high-impedance state and are not referred to the DQ levels.

Timing Waveforms

Read Cycle

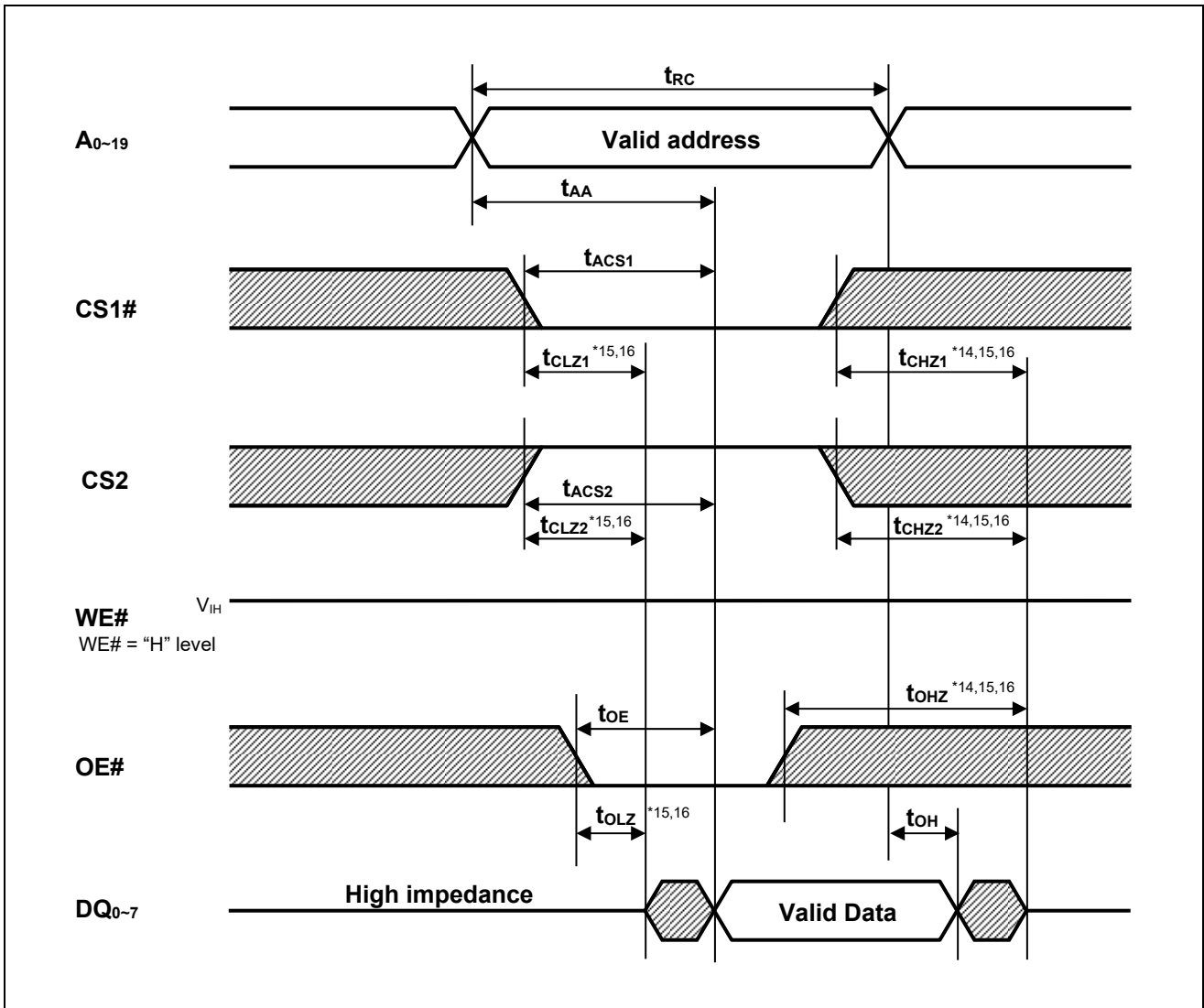

- Note 14. t_{CHZ1} , t_{CHZ2} and t_{OHZ} are defined as the time when the DQ pins enter a high-impedance state and are not referred to the DQ levels.
15. This parameter is sampled and not 100% tested
16. At any given temperature and voltage condition, t_{CHZ1} max is less than t_{CLZ1} min, t_{CHZ2} max is less than t_{CLZ2} min, and t_{OHZ} max is less than t_{OLZ} min, for any device.

Write Cycle (1) (WE# CLOCK, OE#="H" while writing)

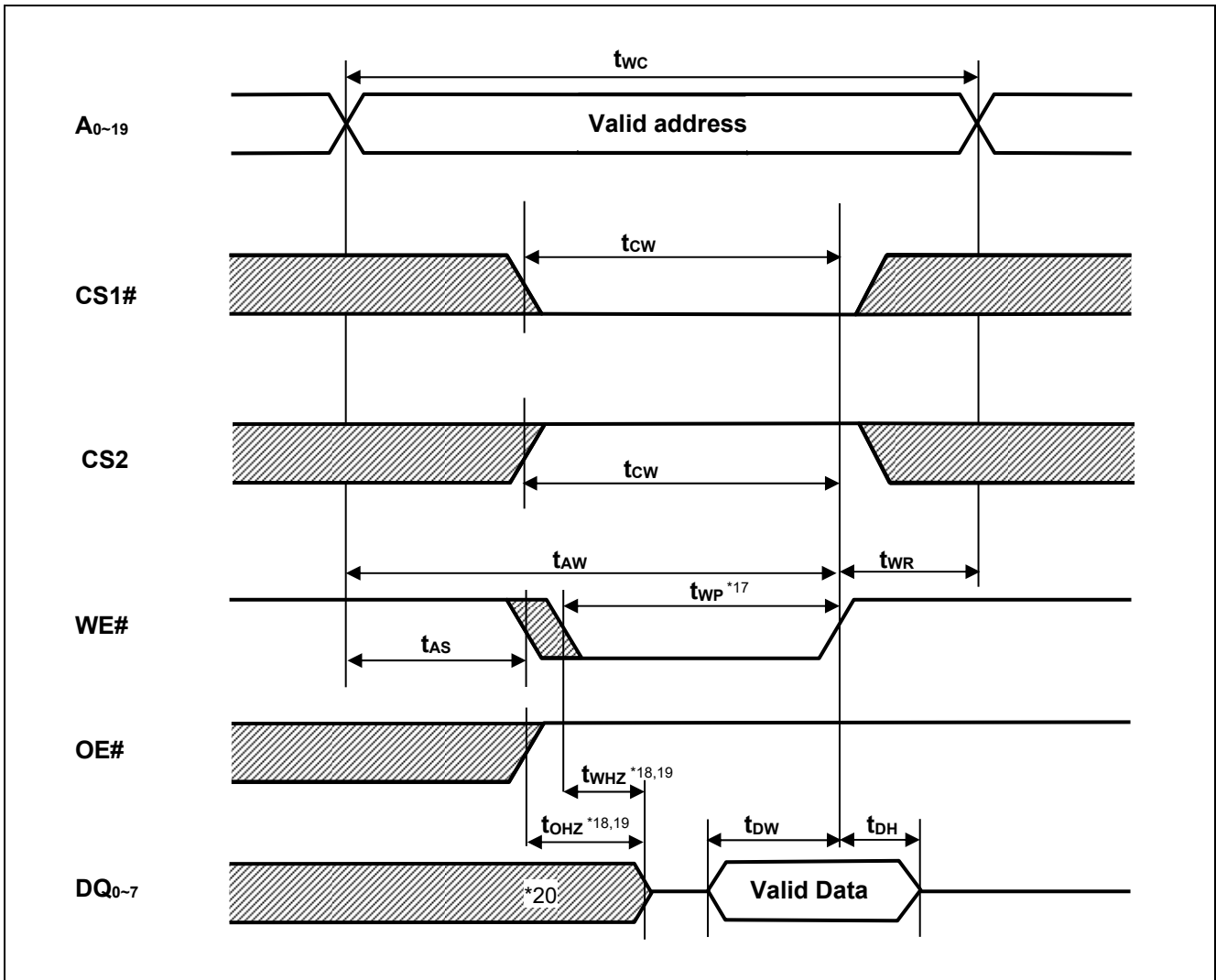

Note 17. t_{WP} is the interval between write start and write end.

A write starts when all of (CS1#), (WE#) and (CS2) become active.

A write is performed during the overlap of a low CS1#, a low WE# and a high CS2.

A write ends when any of (CS1#), (WE#) or (CS2) becomes inactive.

18. t_{OHZ} and t_{WHZ} are defined as the time when the DQ pins enter a high-impedance state and are not referred to the DQ levels.

19. This parameter is sampled and not 100% tested

20. During this period, DQ pins are in the output state so input signals must not be applied to the DQ pins.

Write Cycle (2) (WE# CLOCK, OE# Low Fixed)

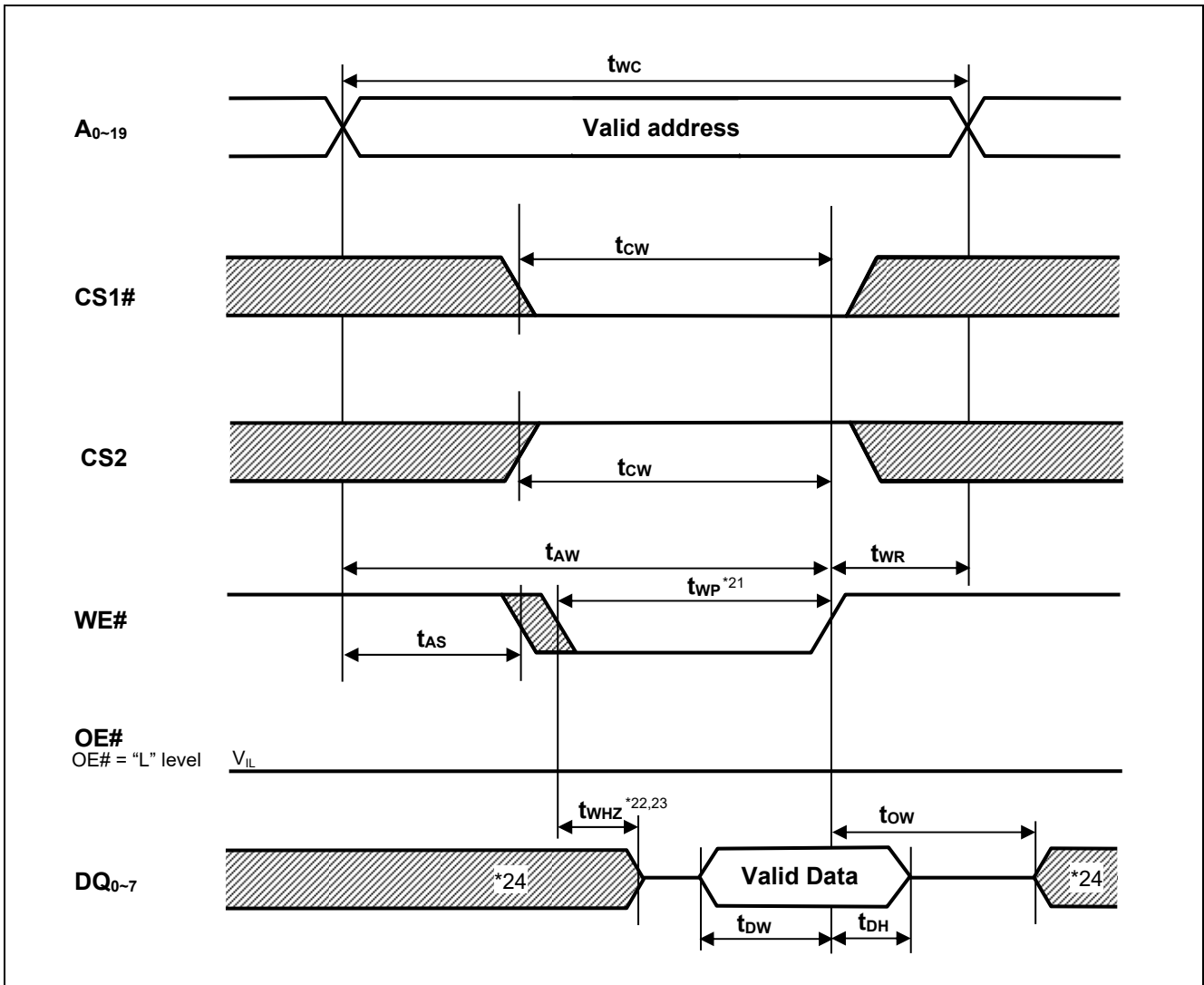

- Note 21. t_{WP} is the interval between write start and write end.
 A write starts when all of ($CS1\#$), ($WE\#$) and ($CS2$) become active.
 A write is performed during the overlap of a low $CS1\#$, a low $WE\#$ and a high $CS2$.
 A write ends when any of ($CS1\#$), ($WE\#$) or ($CS2$) becomes inactive.
22. t_{WHZ} is defined as the time when the DQ pins enter a high-impedance state and are not referred to the DQ levels.
23. This parameter is sampled and not 100% tested.
24. During this period, DQ pins are in the output state so input signals must not be applied to the DQ pins.

Write Cycle (3) (CS1#, CS2 CLOCK)

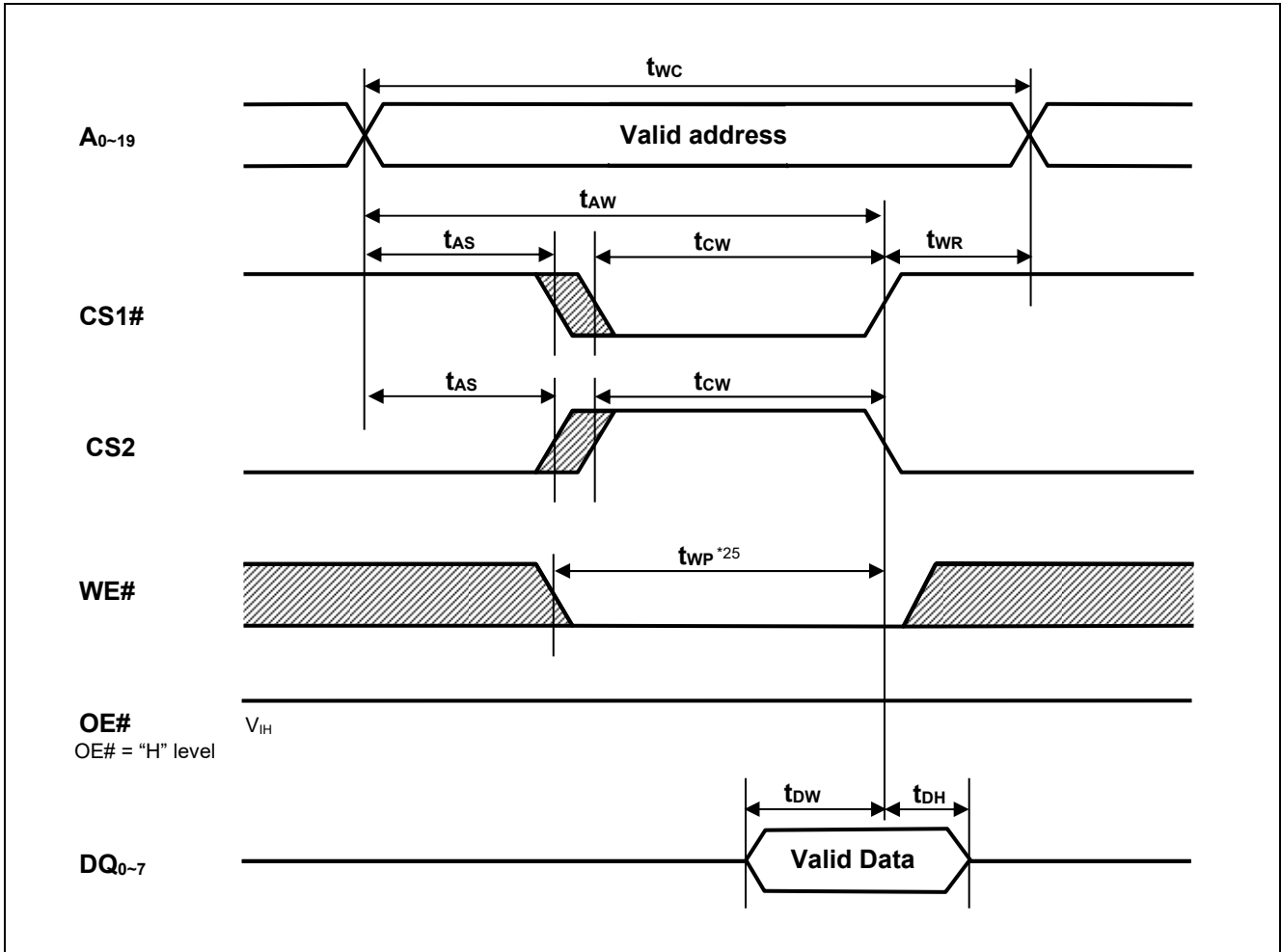

Note 25. t_{WP} is the interval between write start and write end.
 A write starts when all of (CS1#), (WE#) and (CS2) become active.
 A write is performed during the overlap of a low CS1#, a low WE# and a high CS2.
 A write ends when any of (CS1#), (WE#) or (CS2) becomes inactive.

Low V_{CC} Data Retention Characteristics

Parameter	Symbol	Min.	Typ.	Max.	Unit	Test conditions ^{*28}	
V _{CC} for data retention	V _{DR}	1.5	—	3.6	V	V _{in} ≥ 0V, (1) CS2 ≤ 0.2V or (2) CS1# ≥ V _{CC} -0.2V, CS2 ≥ V _{CC} -0.2V	
Data retention current	I _{CCDR}	—	0.45 ^{*26}	2	μA	~+25°C	V _{CC} = 3.0V, V _{in} ≥ 0V, (1) CS2 ≤ 0.2V or (2) CS1# ≥ V _{CC} -0.2V, CS2 ≥ V _{CC} -0.2V
		—	0.6 ^{*27}	4	μA	~+40°C	
		—	—	7	μA	~+70°C	
		—	—	10	μA	~+85°C	
Chip deselect time to data retention	t _{CDR}	0	—	—	ns	See retention waveform.	
Operation recovery time	t _R	5	—	—	ms		

Note 26. Typical parameter indicates the value for the center of distribution at 3.0V (T_a=25°C), and not 100% tested.

27. Typical parameter indicates the value for the center of distribution at 3.0V (T_a=40°C), and not 100% tested.

28. CS2 controls address buffer, WE# buffer, CS1# buffer, OE# buffer and DQ buffer. If CS2 controls data retention mode, V_{in} levels (address, WE#, CS1#, OE#, DQ) can be in the high impedance state. If CS1# controls data retention mode, CS2 must be CS2 ≥ V_{CC}-0.2V or CS2 ≤ 0.2V. The other inputs levels (address, WE#, OE#, DQ) can be in the high-impedance state.

Low V_{CC} Data Retention Timing Waveforms (CS1# controlled)

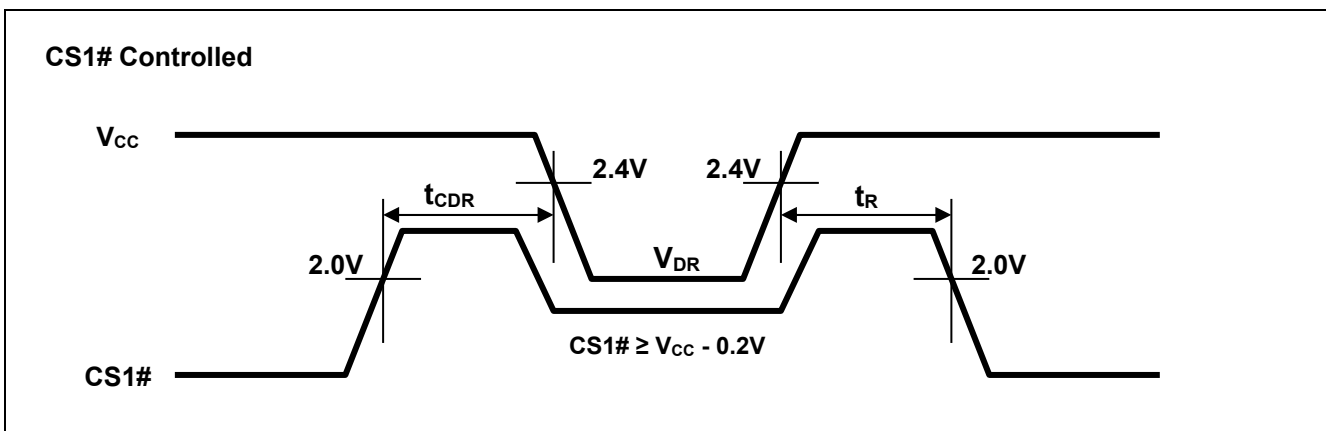

Low V_{CC} Data Retention Timing Waveforms (CS2 controlled)

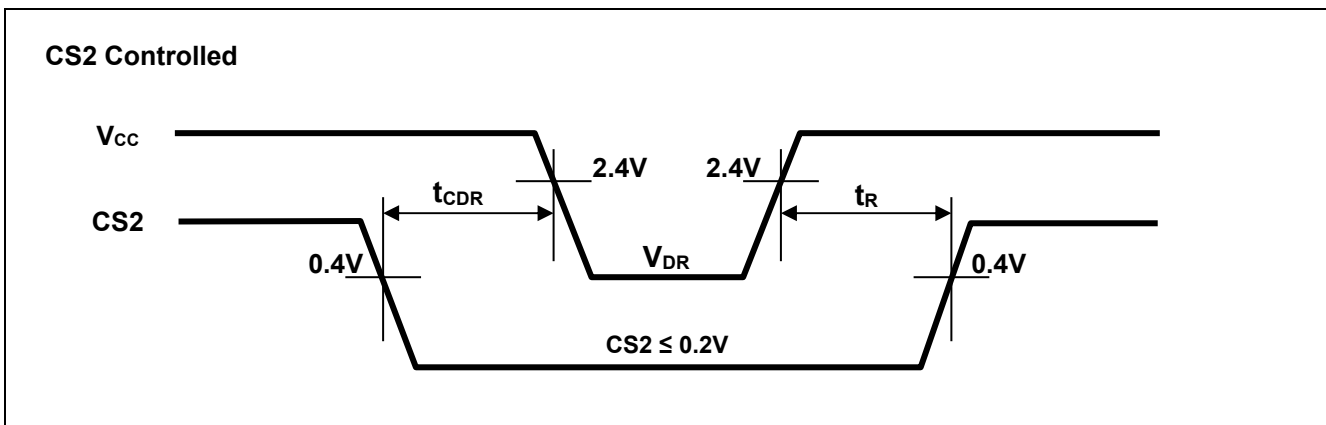

Revision History	RMLV0808BGSB Data Sheet
------------------	-------------------------

Rev.	Date	Description	
		Page	Summary
1.00	2014.11.28	—	First Edition issued
2.00	2015.06.26	P.1, 4 P.2 P.4 P.11	Standby current I_{SB1} : 25°C 0.6μA ->0.45μA (typ.), 40°C 2μA ->0.6μA (typ.) Modify Pin Arrangement : Add 1pin Mark Average operating current I_{CC2} : 25°C 2mA ->1.5mA (typ.) Data retention current I_{CCDR} : 25°C 0.6μA ->0.45μA (typ.), 40°C 2μA ->0.6μA (typ.)
2.01	2020.02.20	Last page	Updated the Notice to the latest version

IMPORTANT NOTICE AND DISCLAIMER

RENESAS ELECTRONICS CORPORATION AND ITS SUBSIDIARIES (“RENESAS”) PROVIDES TECHNICAL SPECIFICATIONS AND RELIABILITY DATA (INCLUDING DATASHEETS), DESIGN RESOURCES (INCLUDING REFERENCE DESIGNS), APPLICATION OR OTHER DESIGN ADVICE, WEB TOOLS, SAFETY INFORMATION, AND OTHER RESOURCES “AS IS” AND WITH ALL FAULTS, AND DISCLAIMS ALL WARRANTIES, EXPRESS OR IMPLIED, INCLUDING, WITHOUT LIMITATION, ANY IMPLIED WARRANTIES OF MERCHANTABILITY, FITNESS FOR A PARTICULAR PURPOSE, OR NON-INFRINGEMENT OF THIRD PARTY INTELLECTUAL PROPERTY RIGHTS.

These resources are intended for developers skilled in the art designing with Renesas products. You are solely responsible for (1) selecting the appropriate products for your application, (2) designing, validating, and testing your application, and (3) ensuring your application meets applicable standards, and any other safety, security, or other requirements. These resources are subject to change without notice. Renesas grants you permission to use these resources only for development of an application that uses Renesas products. Other reproduction or use of these resources is strictly prohibited. No license is granted to any other Renesas intellectual property or to any third party intellectual property. Renesas disclaims responsibility for, and you will fully indemnify Renesas and its representatives against, any claims, damages, costs, losses, or liabilities arising out of your use of these resources. Renesas' products are provided only subject to Renesas' Terms and Conditions of Sale or other applicable terms agreed to in writing. No use of any Renesas resources expands or otherwise alters any applicable warranties or warranty disclaimers for these products.

(Rev.1.0 Mar 2020)

Corporate Headquarters

TOYOSU FORESIA, 3-2-24 Toyosu,
Koto-ku, Tokyo 135-0061, Japan
www.renesas.com

Contact Information



For further information on a product, technology, the most up-to-date version of a document, or your nearest sales office, please visit:
www.renesas.com/contact/

Trademarks

Renesas and the Renesas logo are trademarks of Renesas Electronics Corporation. All trademarks and registered trademarks are the property of their respective owners.

Looking for pricing, stock, or lifecycle information?

Click below to explore more details on WIN SOURCE:

-  [View RMLV0808BGSB-4S2#AA0 on WIN SOURCE](#)
-  [Renesas Electronics America Information](#)

Optimize Your Supply Chain with WIN SOURCE Solutions

-  Global Sourcing Solution
-  Obsolete Management
-  Cost Control Management
-  Shortage Management
-  Alternative Solution
-  Excess Inventory Management