



## FEATURES:

- **Organized as 1M x16 or 2M x8**
- **Dual Bank Architecture for Concurrent Read/Write Operation**
  - 16 Mbit Bottom Sector Protection
    - GLS36VF1601E: 12 Mbit + 4 Mbit
    - 16 Mbit Top Sector Protection
      - GLS36VF1602E: 4 Mbit + 12 Mbit
- **Single 2.7-3.6V for Read and Write Operations**
- **Superior Reliability**
  - Endurance: 100,000 cycles (typical)
  - Greater than 100 years Data Retention
- **Low Power Consumption:**
  - Active Current: 6 mA typical
  - Standby Current: 4  $\mu$ A typical
  - Auto Low Power Mode: 4  $\mu$ A typical
- **Hardware Sector Protection/WP# Input Pin**
  - Protects the 4 outermost sectors (8 KWord) in the larger bank by driving WP# low and unprotects by driving WP# high
- **Hardware Reset Pin (RST#)**
  - Resets the internal state machine to reading array data
- **Byte# Pin**
  - Selects 8-bit or 16-bit mode
- **Sector-Erase Capability**
  - Uniform 2 KWord sectors
- **Chip-Erase Capability**
- **Block-Erase Capability**
  - Uniform 32 KWord blocks
- **Erase-Suspend / Erase-Resume Capabilities**
- **Security ID Feature**
  - Greenliant: 128 bits
  - User: 128 bits
- **Fast Read Access Time**
  - 70 ns
- **Latched Address and Data**
- **Fast Erase and Program (typical):**
  - Sector-Erase Time: 18 ms
  - Block-Erase Time: 18 ms
  - Chip-Erase Time: 35 ms
  - Program Time: 7  $\mu$ s
- **Automatic Write Timing**
  - Internal V<sub>PP</sub> Generation
- **End-of-Write Detection**
  - Toggle Bit
  - Data# Polling
  - Ready/Busy# pin
- **CMOS I/O Compatibility**
- **Conforms to Common Flash Memory Interface (CFI)**
- **JEDEC Standards**
  - Flash EEPROM Pinouts and command sets
- **Packages Available**
  - 48-ball TFBGA (6mm x 8mm)
  - 48-lead TSOP (12mm x 20mm)

## PRODUCT DESCRIPTION

The GLS36VF1601E and GLS36VF1602E are 1M x16 or 2M x8 CMOS Concurrent Read/Write Flash Memory manufactured with Greenliant's proprietary, high performance CMOS SuperFlash memory technology. The split-gate cell design and thick oxide tunneling injector attain better reliability and manufacturability compared with alternate approaches. The devices write (Program or Erase) with a 2.7-3.6V power supply and conform to JEDEC standard pinouts for x8/x16 memories.

Featuring high performance Program, these devices provide a typical Program time of 7  $\mu$ sec and use the Toggle Bit, Data# Polling, or RY/BY# to detect the completion of the Program or Erase operation. To protect against inad-

vertent write, the devices have on-chip hardware and Software Data Protection schemes. Designed, manufactured, and tested for a wide spectrum of applications, these devices are offered with a guaranteed endurance of 10,000 cycles. Data retention is rated at greater than 100 years.

These devices are suited for applications that require convenient and economical updating of program, configuration, or data memory. For all system applications, the devices significantly improve performance and reliability, while lowering power consumption. Since for any given voltage range, the SuperFlash technology uses less current to program and has a shorter erase time, the total energy consumed during any Erase or Program operation

## Data Sheet

is less than alternative flash technologies. These devices also improve flexibility while lowering the cost for program, data, and configuration storage applications.

SuperFlash technology provides fixed Erase and Program times, independent of the number of Erase/Program cycles that have occurred. Therefore the system software or hardware does not have to be modified or de-rated as is necessary with alternative flash technologies, whose Erase and Program times increase with accumulated Erase/Program cycles.

To meet high-density, surface-mount requirements, these devices are offered in 48-ball TFBGA and 48-lead TSOP packages. See Figures 6 and 7 for pin assignments.

## Device Operation

Memory operation functions are initiated using standard microprocessor write sequences. A command is written by asserting WE# low while keeping CE# low. The address bus is latched on the falling edge of WE# or CE#, whichever occurs last. The data bus is latched on the rising edge of WE# or CE#, whichever occurs first.

## Auto Low Power Mode

These devices also have the **Auto Lower Power** mode which puts them in a near standby mode within 500 ns after data has been accessed with a valid Read operation. This reduces the I<sub>DD</sub> active Read current to 4 µA typically. While CE# is low, the devices exit Auto Low Power mode with any address transition or control signal transition used to initiate another Read cycle, with no access time penalty.

## Concurrent Read/Write Operation

The dual bank architecture of these devices allows the Concurrent Read/Write operation whereby the user can read from one bank while programming or erasing in the other bank. For example, reading system code in one bank while updating data in the other bank.

**TABLE 1: Concurrent Read/Write State**

Bank 1	Bank 2
Read	No Operation
Read	Write
Write	Read
Write	No Operation
No Operation	Read
No Operation	Write

**Note:** For the purposes of this table, write means to perform Block- or Sector-Erase or Program operations as applicable to the appropriate bank.

## Read Operation

The Read operation is controlled by CE# and OE#; both have to be low for the system to obtain data from the outputs. CE# is used for device selection. When CE# is high, the chip is deselected and only standby power is consumed. OE# is the output control and is used to gate data from the output pins. The data bus is in a high impedance state when either CE# or OE# is high. Refer to the Read cycle timing diagram for further details (Figure 8).

## Program Operation

These devices are programmed on a word-by-word or byte-by-byte basis depending on the state of the BYTE# pin. Before programming, one must ensure that the sector which is being programmed is fully erased.

The Program operation is accomplished in three steps:

1. Software Data Protection is initiated using the three-byte load sequence.
2. Address and data are loaded.

During the Program operation, the addresses are latched on the falling edge of either CE# or WE#, whichever occurs last. The data is latched on the rising edge of either CE# or WE#, whichever occurs first.

3. The internal Program operation is initiated after the rising edge of the fourth WE# or CE#, whichever occurs first. The Program operation, once initiated, will be completed typically within 7  $\mu$ s.

See Figures 9 and 10 for WE# and CE# controlled Program operation timing diagrams and Figure 24 for flowcharts. During the Program operation, the only valid reads are Data# Polling and Toggle Bit. During the internal Program operation, the host is free to perform additional tasks. Any commands issued during an internal Program operation are ignored.

## Sector-Erase/Block-Erase Operation

These devices offer both Sector-Erase and Block-Erase operations. These operations allow the system to erase the devices on a sector-by-sector (or block-by-block) basis. The sector architecture is based on a uniform sector size of 2 KWord. The Block-Erase mode is based on a uniform block size of 32 KWord. The Sector-Erase operation is initiated by executing a six-byte command sequence with a Sector-Erase command (30H) and sector address (SA) in the last bus cycle. The Block-Erase operation is initiated by executing a six-byte command sequence with Block-Erase command (50H) and block address (BA) in the last bus cycle. The sector or block address is latched on the falling edge of the sixth WE# pulse, while the command (30H or 50H) is latched on the rising edge of the sixth WE# pulse. The internal Erase operation begins after the sixth WE# pulse. Any commands issued during the Sector- or Block-Erase operation are ignored except Erase-Suspend and Erase-Resume. See Figures 14 and 15 for timing waveforms.

## Chip-Erase Operation

The devices provide a Chip-Erase operation, which allows the user to erase all sectors/blocks to the "1" state. This is useful when a device must be quickly erased.

The Chip-Erase operation is initiated by executing a six-byte command sequence with Chip-Erase command (10H) at address 555H in the last byte sequence. The Erase operation begins with the rising edge of the sixth WE# or CE#, whichever occurs first. During the Erase operation, the only valid Read is Toggle Bit or Data# Polling. Any commands issued during the Chip-Erase operation are ignored. See Table 6 for the command sequence, Figure 13 for timing diagram, and Figure 28 for the flowchart. When WP# is low, any attempt to Chip-Erase will be ignored.

## Data Sheet

**Erase-Suspend/Eraseresume Operations**

The Erase-Suspend operation temporarily suspends a Sector- or Block-Erase operation thus allowing data to be read from any memory location, or program data into any sector/block that is not suspended for an Erase operation. The operation is executed by issuing a one-byte command sequence with Erase-Suspend command (B0H). The device automatically enters read mode no more than 10  $\mu$ s after the Erase-Suspend command had been issued. ( $T_{ES}$  maximum latency equals 10  $\mu$ s.) Valid data can be read from any sector or block that is not suspended from an Erase operation. Reading at address location within erase-suspended sectors/blocks will output DQ<sub>2</sub> toggling and DQ<sub>6</sub> at "1". While in Erase-Suspend mode, a Program operation is allowed except for the sector or block selected for Erase-Suspend. To resume Sector-Erase or Block-Erase operation which has been suspended, the system must issue an Erase-Resume command. The operation is executed by issuing a one-byte command sequence with Erase Resume command (30H) at any address in the one-byte sequence.

**Write Operation Status Detection**

These devices provide one hardware and two software means to detect the completion of a Write (Program or Erase) cycle in order to optimize the system Write cycle time. The hardware detection uses the Ready/Busy# (RY/BY#) output pin. The software detection includes two status bits: Data# Polling (DQ<sub>7</sub>) and Toggle Bit (DQ<sub>6</sub>). The End-of-Write detection mode is enabled after the rising edge of WE#, which initiates the internal Program or Erase operation.

The actual completion of the nonvolatile write is asynchronous with the system; therefore, either a Ready/Busy# (RY/BY#), a Data# Polling (DQ<sub>7</sub>), or Toggle Bit (DQ<sub>6</sub>) Read may be simultaneous with the completion of the Write cycle. If this occurs, the system may get an erroneous result, i.e., valid data may appear to conflict with either DQ<sub>7</sub> or DQ<sub>6</sub>. In order to prevent spurious rejection if an erroneous result occurs, the software routine should include a loop to read the accessed location an additional two (2) times. If both Reads are valid, then the Write cycle has completed, otherwise the rejection is valid.

**Ready/Busy# (RY/BY#)**

The devices include a Ready/Busy# (RY/BY#) output signal. RY/BY# is an open drain output pin that indicates whether an Erase or Program operation is in progress. Since RY/BY# is an open drain output, it allows several devices to be tied in parallel to V<sub>DD</sub> via an external pull-up resistor. After the rising edge of the final WE# pulse in the command sequence, the RY/BY# status is valid.

When RY/BY# is actively pulled low, it indicates that an Erase or Program operation is in progress. When RY/BY# is high (Ready), the devices may be read or left in standby mode.

**Byte/Word (BYTE#)**

The device includes a BYTE# pin to control whether the device data I/O pins operate x8 or x16. If the BYTE# pin is at logic "1" (V<sub>IH</sub>) the device is in x16 data configuration: all data I/O pins DQ<sub>0</sub>-DQ<sub>15</sub> are active and controlled by CE# and OE#.

If the BYTE# pin is at logic "0", the device is in x8 data configuration: only data I/O pins DQ<sub>0</sub>-DQ<sub>7</sub> are active and controlled by CE# and OE#. The remaining data pins DQ<sub>8</sub>-DQ<sub>14</sub> are at Hi-Z, while pin DQ<sub>15</sub> is used as the address input A<sub>-1</sub> for the Least Significant Bit of the address bus.

**Data# Polling (DQ<sub>7</sub>)**

When the devices are in an internal Program operation, any attempt to read DQ<sub>7</sub> will produce the complement of the true data. Once the Program operation is completed, DQ<sub>7</sub> will produce true data. During internal Erase operation, any attempt to read DQ<sub>7</sub> will produce a '0'. Once the internal Erase operation is completed, DQ<sub>7</sub> will produce a '1'. The Data# Polling is valid after the rising edge of fourth WE# (or CE#) pulse for Program operation. For Sector-, Block-, or Chip-Erase, the Data# Polling is valid after the rising edge of sixth WE# (or CE#) pulse. See Figure 11 for Data# Polling (DQ<sub>7</sub>) timing diagram and Figure 25 for a flowchart.

## Toggle Bits (DQ<sub>6</sub> and DQ<sub>2</sub>)

During the internal Program or Erase operation, any consecutive attempts to read DQ<sub>6</sub> will produce alternating “1”s and “0”s, i.e., toggling between 1 and 0. When the internal Program or Erase operation is completed, the DQ<sub>6</sub> bit will stop toggling. The device is then ready for the next operation. The toggle bit is valid after the rising edge of the fourth WE# (or CE#) pulse for Program operations. For Sector-, Block-, or Chip-Erase, the toggle bit (DQ<sub>6</sub>) is valid after the rising edge of sixth WE# (or CE#) pulse. DQ<sub>6</sub> will be set to “1” if a Read operation is attempted on an Erase-suspended Sector/Block. If Program operation is initiated in a sector/block not selected in Erase-Suspend mode, DQ<sub>6</sub> will toggle.

An additional Toggle Bit is available on DQ<sub>2</sub>, which can be used in conjunction with DQ<sub>6</sub> to check whether a particular sector is being actively erased or erase-suspended. Table 2 shows detailed status bit information. The Toggle Bit (DQ<sub>2</sub>) is valid after the rising edge of the last WE# (or CE#) pulse of a Write operation. See Figure 12 for Toggle Bit timing diagram and Figure 25 for a flowchart.

**TABLE 2: Write Operation Status**

Status		DQ <sub>7</sub>	DQ <sub>6</sub>	DQ <sub>2</sub>	RY/BY#
Normal Operation	Standard Program	DQ7#	Toggle	No Toggle	0
	Standard Erase	0	Toggle	Toggle	0
Erase-Suspend Mode	Read From Erase Suspended Sector/Block	1	1	Toggle	1
	Read From Non-Erase Suspended Sector/Block	Data	Data	Data	1
	Program	DQ7#	Toggle	N/A	0

T2.1 1274

**Note:** DQ<sub>7</sub>, DQ<sub>6</sub>, and DQ<sub>2</sub> require a valid address when reading status information. The address must be in the bank where the operation is in progress in order to read the operation status. If the address is pointing to a different bank (not busy), the device will output array data.

## Data Protection

The devices provide both hardware and software features to protect nonvolatile data from inadvertent writes.

### Hardware Data Protection

**Noise/Glitch Protection:** A WE# or CE# pulse of less than 5 ns will not initiate a Write cycle.

**V<sub>DD</sub> Power Up/Down Detection:** The Write operation is inhibited when V<sub>DD</sub> is less than 1.5V.

**Write Inhibit Mode:** Forcing OE# low, CE# high, or WE# high will inhibit the Write operation. This prevents inadvertent writes during power-up or power-down.

### Hardware Block Protection

The devices provide hardware block protection which protects the outermost 8 KWord in the larger bank. The block is protected when WP# is held low. See Figures 2, 3, 4, and 5 for Block-Protection location.

A user can disable block protection by driving WP# high. This allows data to be erased or programmed into the protected sectors. WP# must be held high prior to issuing the Write command and remain stable until after the entire Write operation has completed. If WP# is left floating, it is internally held high via a pull-up resistor, and the Boot Block is unprotected, enabling Program and Erase operations on that block.

### Hardware Reset (RST#)

The RST# pin provides a hardware method of resetting the devices to read array data. When the RST# pin is held low for at least T<sub>RP</sub>, any in-progress operation will terminate and return to Read mode (see Figure 21). When no internal Program/Erase operation is in progress, a minimum period of T<sub>RHR</sub> is required after RST# is driven high before a valid Read can take place (see Figure 20).

The Erase operation that has been interrupted needs to be reinitiated after the device resumes normal operation mode to ensure data integrity.

## Data Sheet

**Software Data Protection (SDP)**

These devices provide the JEDEC standard Software Data Protection scheme for all data alteration operations, i.e., Program and Erase. Any Program operation requires the inclusion of the three-byte sequence. The three-byte load sequence is used to initiate the Program operation, providing optimal protection from inadvertent Write operations, e.g., during the system power-up or power-down. Any Erase operation requires the inclusion of the six-byte sequence. The devices are shipped with the Software Data Protection permanently enabled. See Table 6 for the specific software command codes. During SDP command sequence, invalid commands will abort the device to Read mode within  $T_{RC}$ . The contents of  $DQ_{15}$ - $DQ_8$  can be  $V_{IL}$  or  $V_{IH}$ , but no other value during any SDP command sequence.

**Common Flash Memory Interface (CFI)**

These devices also contain the CFI information to describe the characteristics of the devices. In order to enter the CFI Query mode, the system must write the three-byte sequence, same as the Software ID Entry command with 98H (CFI Query command) to address 555H in the last byte sequence. See Figure 17 for CFI Entry and Read timing diagram. Once the device enters the CFI Query mode, the system can read CFI data at the addresses given in Tables 7 through 9. The system must write the CFI Exit command to return to Read mode from the CFI Query mode.

**Security ID**

The GLS36VF160xE devices offer a 256-bit Security ID space. The Secure ID space is divided into two 128-bit segments—one factory programmed segment and one user programmed segment. The first segment is programmed and locked at Greenliant with a unique, 128-bit number. The user segment is left un-programmed for the customer to program as desired. To program the user segment of the Security ID, the user must use the Security ID Program command. End-of-Write status is checked by reading the toggle bits. Data# Polling is not used for Security ID End-of-Write detection. Once programming is complete, the Sec ID should be locked using the User Sec ID Program Lock-Out. This disables any future corruption of this space. Note that regardless of whether or not the Sec ID is locked, neither Sec ID segment can be erased. The Secure ID space can be queried by executing a three-byte command sequence with Query Sec ID command (88H) at address 555H in the last byte sequence. See Figure 19 for timing diagram. To exit this mode, the Exit Sec ID command should be executed. Refer to Table 6 for more details.

**Product Identification**

The Product Identification mode identifies the devices and manufacturer. For details, see Table 3 for software operation, Figure 16 for the Software ID Entry and Read timing diagram and Figure 26 for the Software ID Entry command sequence flowchart. The addresses A<sub>19</sub> and A<sub>18</sub> indicate a bank address. When the addressed bank is switched to Product Identification mode, it is possible to read another address from the same bank without issuing a new Software ID Entry command.

**TABLE 3: Product Identification**

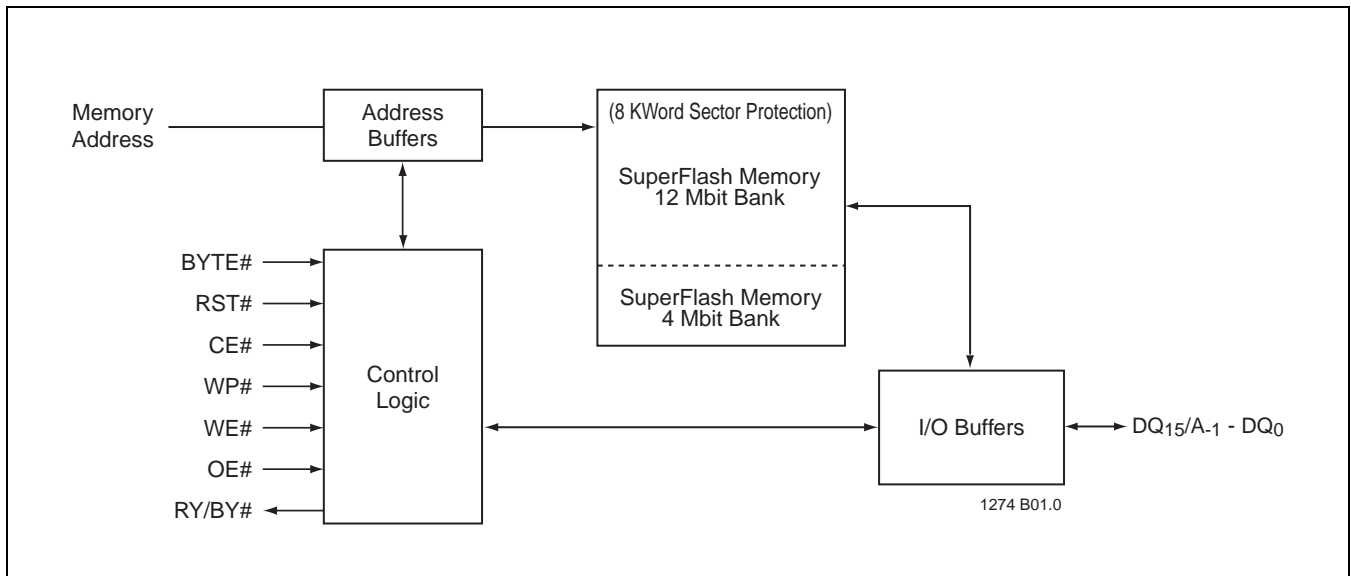
	Address	Data
Manufacturer's ID	BK0000H	00BFH
Device ID		
GLS36VF1601E	BK0001H	734BH
GLS36VF1602E	BK0001H	734AH

T3.0 1274

**Note:** BK = Bank Address (A<sub>19</sub>-A<sub>18</sub>)

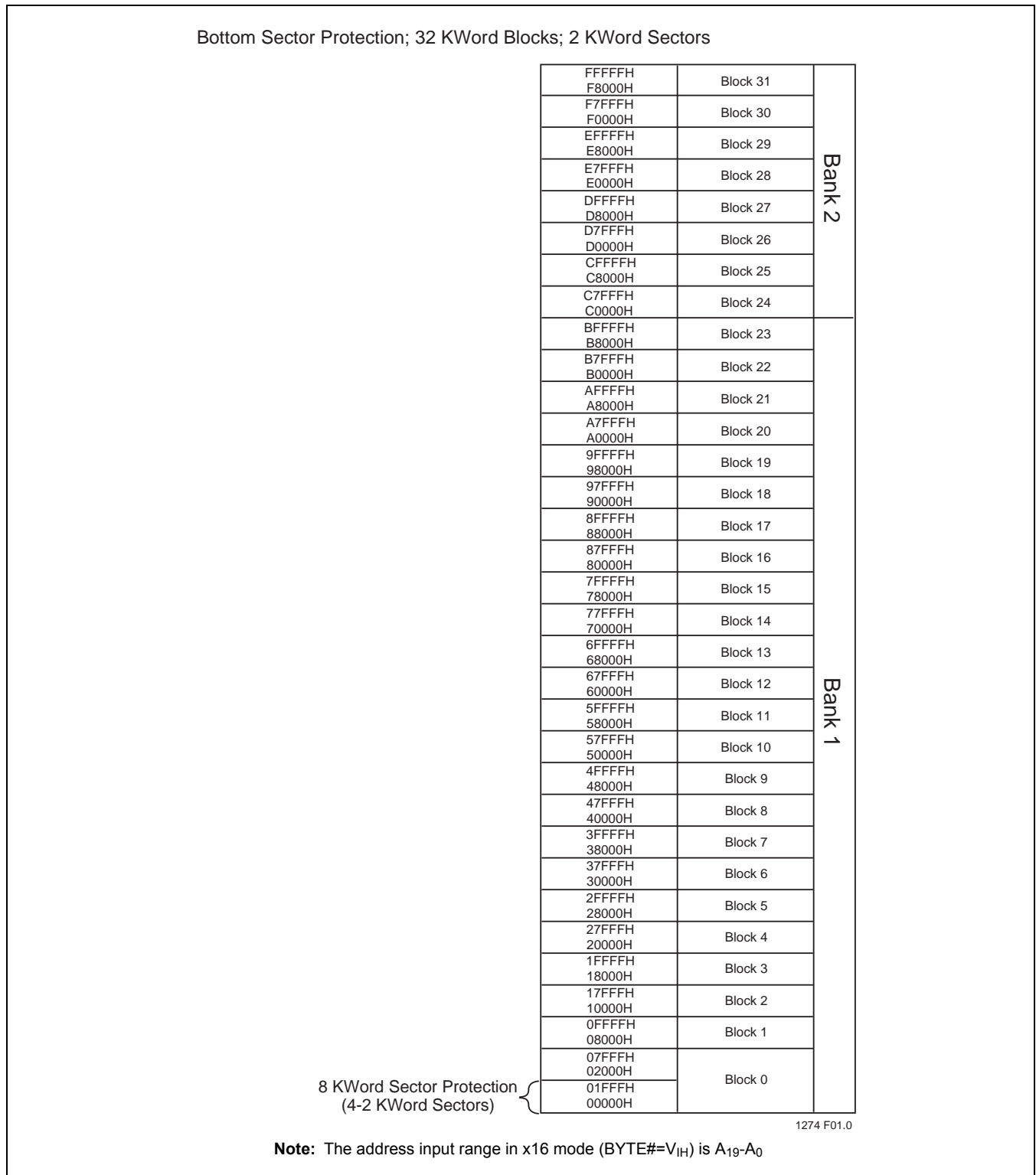
**Product Identification Mode Exit/CFI Mode Exit**

In order to return to the standard Read mode, the Software Product Identification mode must be exited. Exit is accomplished by issuing the Software ID Exit command sequence, which returns the device to the Read mode. This command may also be used to reset the device to the Read mode after any inadvertent transient condition that apparently causes the device to behave abnormally, e.g., not read correctly. Please note that the Software ID Exit/CFI Exit command is ignored during an internal Program or Erase operation. See Table 6 for the software command code, Figure 18 for timing waveform and Figure 27 for a flowchart.

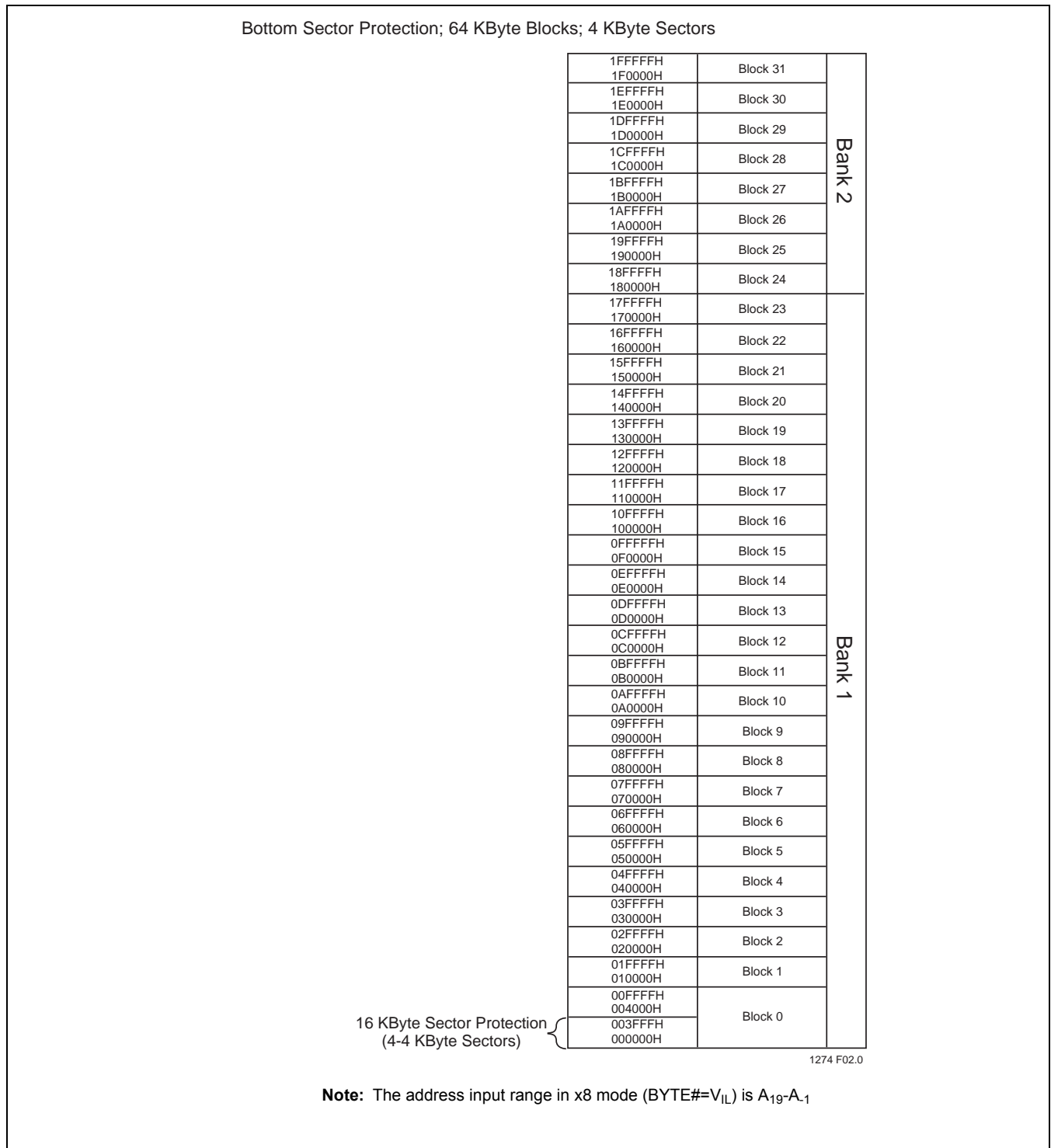


**FIGURE 1: Functional Block Diagram**

Data Sheet

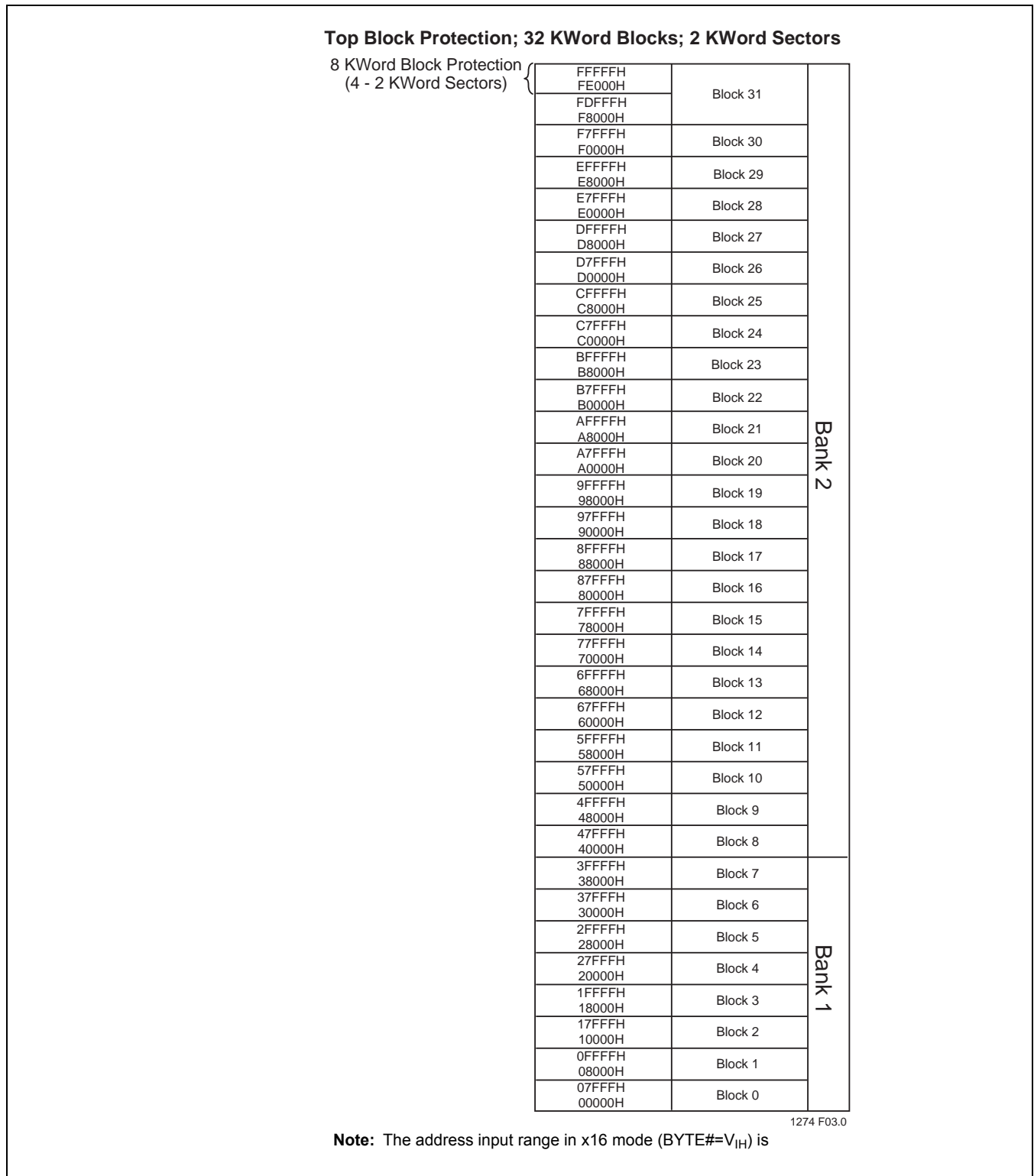


**FIGURE 2: GLS36VF1601E, 1M x16 Concurrent SuperFlash Dual-Bank Memory Organization**

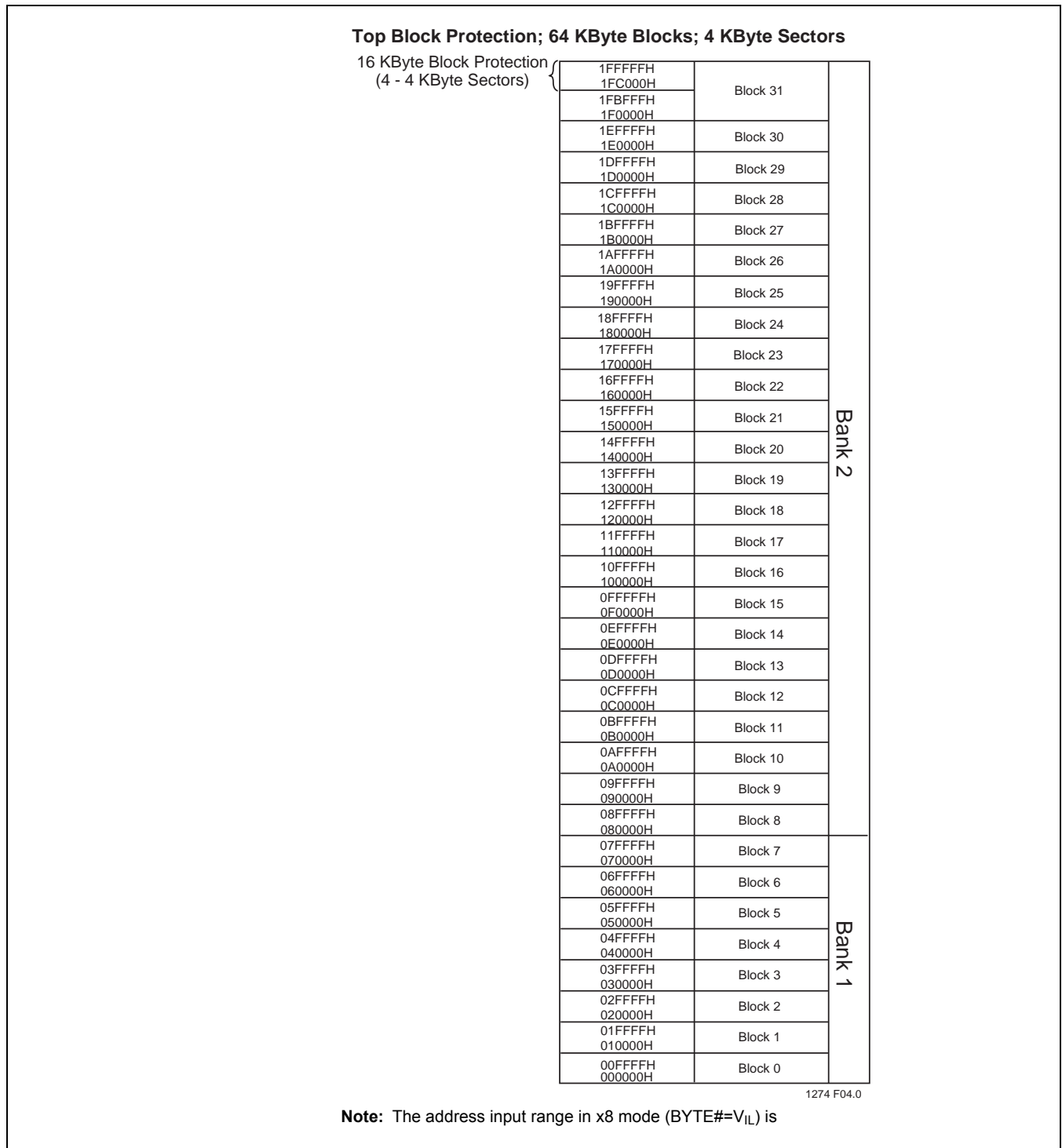


**FIGURE 3: GLS36VF1601E, 2M x8 Concurrent SuperFlash Dual-Bank Memory Organization**

Data Sheet

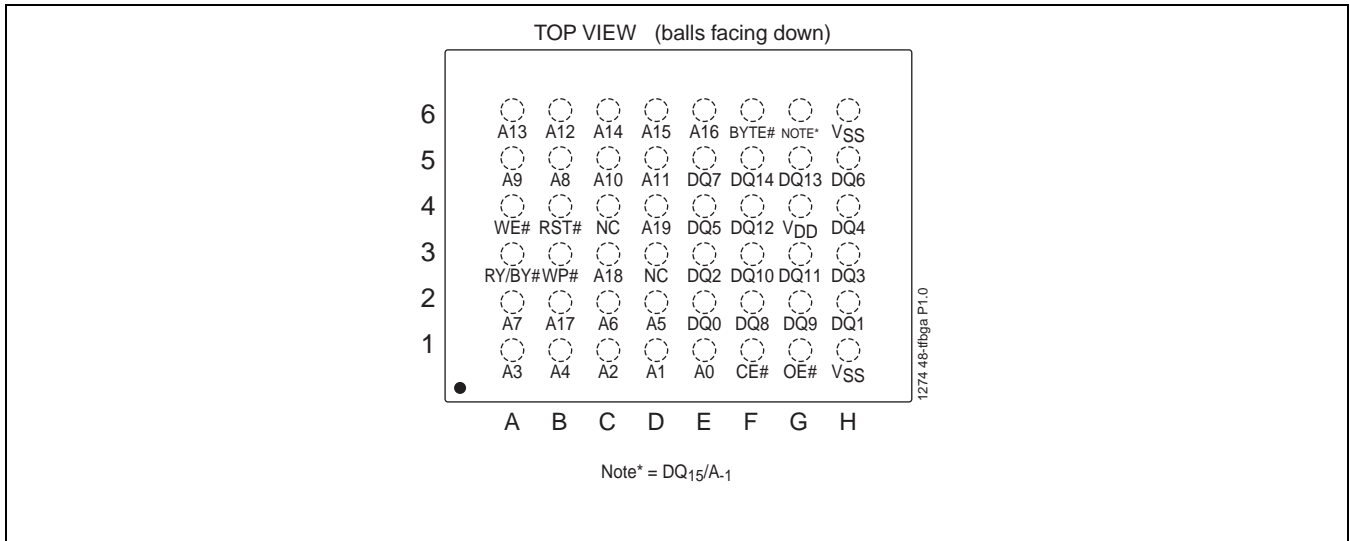


**FIGURE 4: GLS36VF1602E, 1M x16 Concurrent SuperFlash Dual-Bank Memory Organization**

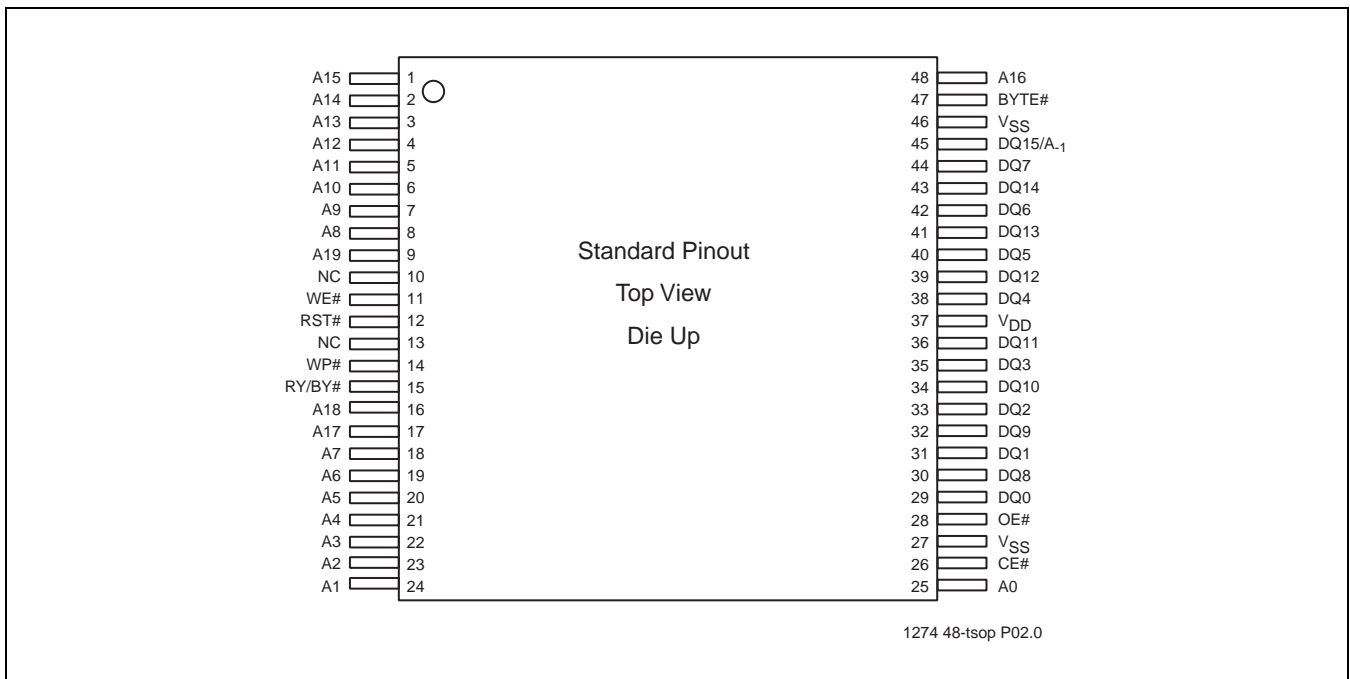


**FIGURE 5: GLS36VF1602E, 2M x8 Concurrent SuperFlash Dual-Bank Memory Organization**

Data Sheet



**FIGURE 6: Pin Assignments for 48-ball TFBGA (6mm x 8mm)**



**FIGURE 7: Pin Assignments for 48-lead TSOP (12mm x 20mm)**

**TABLE 4: Pin Description**

Symbol	Name	Functions
A <sub>19</sub> -A <sub>0</sub>	Address Inputs	To provide memory addresses. During Sector-Erase and Hardware Sector Protection, A <sub>19</sub> -A <sub>11</sub> address lines will select the sector. During Block-Erase A <sub>19</sub> -A <sub>15</sub> address lines will select the block.
DQ <sub>14</sub> -DQ <sub>0</sub>	Data Input/Output	To output data during Read cycles and receive input data during Write cycles. Data is internally latched during a Write cycle. The outputs are in tri-state when OE# or CE# is high.
DQ <sub>15</sub> /A <sub>-1</sub>	Data Input/Output and LBS Address	DQ <sub>15</sub> is used as data I/O pin when in x16 mode (BYTE# = "1") A <sub>-1</sub> is used as the LSB address pin when in x8 mode (BYTE# = "0")
CE#	Chip Enable	To activate the device when CE# is low.
OE#	Output Enable	To gate the data output buffers
WE#	Write Enable	To control the Write operations
RST#	Hardware Reset	To reset and return the device to Read mode
RY/BY#	Ready/Busy#	To output the status of a Program or Erase operation RY/BY# is an open drain output, so a 10KΩ - 100KΩ pull-up resistor is required to allow RY/BY# to transition high indicating the device is ready to read.
WP#	Write Protect	To protect and unprotect top or bottom 8 KWord (4 outermost sectors) from Erase or Program operation.
BYTE#	Word/Byte Configuration	To select 8-bit or 16-bit mode.
V <sub>DD</sub>	Power Supply	To provide 2.7-3.6V power supply voltage
V <sub>SS</sub>	Ground	
NC	No Connection	Unconnected pins

T4.0 1274

**TABLE 5: Operation Modes Selection**

Mode <sup>1</sup>	CE#	OE#	WE#	DQ <sub>7</sub> -DQ <sub>0</sub>	DQ <sub>15</sub> -DQ <sub>8</sub>		Address
					BYTE# = V <sub>IH</sub>	BYTE# = V <sub>IL</sub>	
Read	V <sub>IL</sub>	V <sub>IL</sub>	V <sub>IH</sub>	D <sub>OUT</sub>	D <sub>OUT</sub>	DQ <sub>14</sub> -DQ <sub>8</sub> = High Z	A <sub>IN</sub>
Program	V <sub>IL</sub>	V <sub>IH</sub>	V <sub>IL</sub>	D <sub>IN</sub>	D <sub>IN</sub>	DQ <sub>15</sub> = A <sub>-1</sub>	A <sub>IN</sub>
Erase	V <sub>IL</sub>	V <sub>IH</sub>	V <sub>IL</sub>	X <sup>2</sup>	X	High Z	Sector or Block address, 555H for Chip-Erase
Standby	V <sub>IHC</sub>	X	X	High Z	High Z	High Z	X
Write Inhibit	X	V <sub>IL</sub>	X	High Z / D <sub>OUT</sub>	High Z / D <sub>OUT</sub>	High Z	X
	X	X	V <sub>IH</sub>	High Z / D <sub>OUT</sub>	High Z / D <sub>OUT</sub>	High Z	X
Product Identification							
Software Mode	V <sub>IL</sub>	V <sub>IL</sub>	V <sub>IH</sub>	Manufacturer's ID (BFH)	Manufacturer's ID (00H)	High Z	See Table 6
				Device ID <sup>3</sup>	Device ID <sup>3</sup>	High Z	

T5.2 1274

1. RST# = V<sub>IH</sub> for all described operation modes
2. X can be V<sub>IL</sub> or V<sub>IH</sub>, but no other value.
3. Device ID =  
GLS36VF1601E = 734BH,  
GLS36VF1602E = 734AH

Data Sheet

**TABLE 6: Software Command Sequence**

Command Sequence	1st Bus Write Cycle		2nd Bus Write Cycle		3rd Bus Write Cycle		4th Bus Write Cycle		5th Bus Write Cycle		6th Bus Write Cycle	
	Addr <sup>1</sup>	Data <sup>2</sup>	Addr <sup>1</sup>	Data <sup>2</sup>	Addr <sup>1</sup>	Data <sup>2</sup>	Addr <sup>1</sup>	Data <sup>2</sup>	Addr <sup>1</sup>	Data <sup>2</sup>	Addr <sup>1</sup>	Data <sup>2</sup>
Program	555H	AAH	2AAH	55H	555H	A0H	WA <sup>3</sup>	Data				
Sector-Erase	555H	AAH	2AAH	55H	555H	80H	555H	AAH	2AAH	55H	SA <sub>X</sub> <sup>4</sup>	30H
Block-Erase	555H	AAH	2AAH	55H	555H	80H	555H	AAH	2AAH	55H	BA <sub>X</sub> <sup>4</sup>	50H
Chip-Erase	555H	AAH	2AAH	55H	555H	80H	555H	AAH	2AAH	55H	555H	10H
Erase-Suspend	XXXXH	B0H										
Erase-Resume	XXXXH	30H										
Query Sec ID <sup>5</sup>	555H	AAH	2AAH	55H	555H	88H						
User Security ID Program	555H	AAH	2AAH	55H	555H	A5H	SIWA <sup>6</sup>	Data				
User Security ID Program Lock-out <sup>7</sup>	555H	AAH	2AAH	55H	555H	85H	XXH	0000H				
Software ID Entry <sup>8</sup>	555H	AAH	2AAH	55H	BK <sub>X</sub> <sup>9</sup> 555H	90H						
CFI Query Entry	555H	AAH	2AAH	55H	BK <sub>X</sub> <sup>9</sup> 555H	98H						
Software ID Exit/ CFI Exit/ Sec ID Exit <sup>10,11</sup>	555H	AAH	2AAH	55H	555H	F0H						
Software ID Exit/ CFI Exit/ Sec ID Exit <sup>10,11</sup>	XXH	F0H										

T6.1 1274

- Address format A<sub>10</sub>-A<sub>0</sub> (Hex), Addresses A<sub>19</sub>-A<sub>11</sub> can be V<sub>IL</sub> or V<sub>IH</sub>, but no other value, for the command sequence when in x16 mode.  
When in x8 mode, Addresses A<sub>19</sub>-A<sub>12</sub>, Address A<sub>1</sub> and DQ<sub>14</sub>-DQ<sub>8</sub> can be V<sub>IL</sub> or V<sub>IH</sub>, but no other value, for the command sequence.
- DQ<sub>15</sub>-DQ<sub>8</sub> can be V<sub>IL</sub> or V<sub>IH</sub>, but no other value, for the command sequence
- WA = Program word/byte address
- SA<sub>X</sub> for Sector-Erase; uses A<sub>19</sub>-A<sub>11</sub> address lines  
BA<sub>X</sub> for Block-Erase; uses A<sub>19</sub>-A<sub>15</sub> address lines
- For GLS36VF1601E,  
Greenliant ID is read with A<sub>3</sub> = 0 (Address range = 00000H to 00007H),  
User ID is read with A<sub>3</sub> = 1 (Address range = 00010H to 00017H).  
Lock Status is read with A<sub>7</sub>-A<sub>0</sub> = 000FFH. Unlocked: DQ<sub>3</sub> = 1 / Locked: DQ<sub>3</sub> = 0.  
For GLS36VF1602E,  
Greenliant ID is read with A<sub>3</sub> = 0 (Address range = C0000H to C0007H),  
User ID is read with A<sub>3</sub> = 1 (Address range = C0010H to C0017H).  
Lock Status is read with A<sub>7</sub>-A<sub>0</sub> = C00FFH. Unlocked: DQ<sub>3</sub> = 1 / Locked: DQ<sub>3</sub> = 0.
- SIWA = User Security ID Program word/byte address  
For GLS36VF1601E, valid Word-Addresses for User Sec ID are from 00010H-00017H.  
For GLS36VF1602E, valid Word-Addresses for User Sec ID are from C0010H-C0017H.  
All 4 cycles of User Security ID Program and Program Lock-out must be completed before going back to Read-Array mode.
- The User Security ID Program Lock-out command must be executed in x16 mode (BYTE#=V<sub>IH</sub>).
- The device does not remain in Software Product Identification mode if powered down.
- A<sub>19</sub> and A<sub>18</sub> = BK<sub>X</sub> (Bank Address): address of the bank that is switched to Software ID/CFI Mode  
With A<sub>17</sub>-A<sub>1</sub> = 0; Greenliant Manufacturer's ID = 00BFH, is read with A<sub>0</sub> = 0  
GLS36VF1601E Device ID = 734BH, is read with A<sub>0</sub> = 1  
GLS36VF1602E Device ID = 734AH, is read with A<sub>0</sub> = 1
- Both Software ID Exit operations are equivalent
- If users never lock after programming, User Sec ID can be programmed over the previously unprogrammed bits (data=1) using the User Sec ID mode again (the programmed "0" bits cannot be reversed to "1").  
For GLS36VF1601E, valid Word-Addresses for User Sec ID are from 00010H-00017H.  
For GLS36VF1602E, valid Word-Addresses for User Sec ID are from C0010H-C0017H.

**TABLE 7: CFI Query Identification String<sup>1</sup>**

Address x16 Mode	Address x8 Mode	Data <sup>2</sup>	Description
10H 11H 12H	20H 22H 24H	0051H 0052H 0059H	Query Unique ASCII string "QRY"
13H 14H	26H 28H	0001H 0007H	Primary OEM command set
15H 16H	2AH 2CH	0000H 0000H	Address for Primary Extended Table
17H 18H	2EH 30H	0000H 0000H	Alternate OEM command set (00H = none exists)
19H 1AH	32H 34H	0000H 0000H	Address for Alternate OEM extended Table (00H = none exists)

T7.0 1274

1. Refer to CFI publication 100 for more details.
2. In x8 mode, only the lower byte of data is output.

**TABLE 8: System Interface Information**

Address x16 Mode	Address x8 Mode	Data <sup>1</sup>	Description
1BH	36H	0027H	V <sub>DD</sub> Min (Program/Erase) DQ <sub>7</sub> -DQ <sub>4</sub> : Volts, DQ <sub>3</sub> -DQ <sub>0</sub> : 100 millivolts
1CH	38H	0036H	V <sub>DD</sub> Max (Program/Erase) DQ <sub>7</sub> -DQ <sub>4</sub> : Volts, DQ <sub>3</sub> -DQ <sub>0</sub> : 100 millivolts
1DH	3AH	0000H	V <sub>PP</sub> min (00H = no V <sub>PP</sub> pin)
1EH	3CH	0000H	V <sub>PP</sub> max (00H = no V <sub>PP</sub> pin)
1FH	3EH	0004H	Typical time out for Program 2 <sup>N</sup> μs (2 <sup>4</sup> = 16 μs)
20H	40H	0000H	Typical time out for min size buffer program 2 <sup>N</sup> μs (00H = not supported)
21H	42H	0004H	Typical time out for individual Sector/Block-Erase 2 <sup>N</sup> ms (2 <sup>4</sup> = 16 ms)
22H	44H	0006H	Typical time out for Chip-Erase 2 <sup>N</sup> ms (2 <sup>6</sup> = 64 ms)
23H	46H	0001H	Maximum time out for Program 2 <sup>N</sup> times typical (2 <sup>1</sup> x 2 <sup>4</sup> = 32 μs)
24H	48H	0000H	Maximum time out for buffer program 2 <sup>N</sup> times typical
25H	4AH	0001H	Maximum time out for individual Sector-/Block-Erase 2 <sup>N</sup> times typical (2 <sup>1</sup> x 2 <sup>4</sup> = 32 ms)
26H	4CH	0001H	Maximum time out for Chip-Erase 2 <sup>N</sup> times typical (2 <sup>1</sup> x 2 <sup>6</sup> = 128 ms)

T8.0 1274

1. In x8 mode, only the lower byte of data is output.

## Data Sheet

**TABLE 9: Device Geometry Information**

Address x16 Mode	Address x8 Mode	Data <sup>1</sup>	Description
27H	4EH	0015H	Device size = 2 <sup>N</sup> Bytes (15H = 21; 2 <sup>21</sup> = 2 MByte)
28H 29H	50H 52H	0002H 0000H	Flash Device Interface description; 0002H = x8/x16 asynchronous interface
2AH 2BH	54H 56H	0000H 0000H	Maximum number of bytes in multi-byte write = 2 <sup>N</sup> (00H = not supported)
2CH	58H	0002H	Number of Erase Sector/Block sizes supported by device
2DH 2EH 2FH 30H	5AH 5CH 5EH 60H	00FFH 0001H 0010H 0000H	Sector Information (y + 1 = Number of sectors; z x 256B = sector size) y = 511 + 1 = 512 sectors (01FFH = 512) z = 16 x 256 Bytes = 4 KByte/sector (0010H = 16)
31H 32H 33H 34H	62H 64H 66H 68H	001FH 0000H 0000H 0001H	Block Information (y + 1 = Number of blocks; z x 256B = block size) y = 31 + 1 = 32 blocks (001FH = 31) z = 256 x 256 Bytes = 64 KByte/block (0100H = 256)

T9.1 1274

1. In x8 mode, only the lower byte of data is output.

# 16 Mbit Concurrent SuperFlash

GLS36VF1601E / GLS36VF1602E



Data Sheet

**Absolute Maximum Stress Ratings** (Applied conditions greater than those listed under “Absolute Maximum Stress Ratings” may cause permanent damage to the device. This is a stress rating only and functional operation of the device at these conditions or conditions greater than those defined in the operational sections of this data sheet is not implied. Exposure to absolute maximum stress rating conditions may affect device reliability.)

Temperature Under Bias	-55°C to +125°C
Storage Temperature	-65°C to +150°C
D. C. Voltage on Any Pin to Ground Potential	-0.5V to $V_{DD}+0.5V$
Transient Voltage (<20 ns) on Any Pin to Ground Potential	-2.0V to $V_{DD}+2.0V$
Package Power Dissipation Capability ( $T_A = 25^\circ C$ )	1.0W
Surface Mount Solder Reflow Temperature	260°C for 10 seconds
Output Short Circuit Current	50 mA

## Operating Range:

Range	Ambient Temp	$V_{DD}$
Commercial	0°C to +70°C	2.7-3.6V
Industrial	-40°C to +85°C	2.7-3.6V

## AC Conditions of Test

Input Rise/Fall Time	5 ns
Output Load	$C_L = 30 \text{ pF}$
See Figures 22 and 23	

Data Sheet

**TABLE 10: DC Operating Characteristics  $V_{DD} = 2.7-3.6V$**

Symbol	Parameter	Freq	Limits			Test Conditions
			Min	Max	Units	
$I_{DD}^1$	Active $V_{DD}$ Current Read	5 MHz		15	mA	$CE\#=V_{IL}, WE\#=OE\#=V_{IH}$
		1 MHz		4	mA	
	Program and Erase Concurrent Read/Write			30	mA	$CE\#=WE\#=V_{IL}, OE\#=V_{IH}$
		5 MHz		45	mA	$CE\#=V_{IL}, OE\#=V_{IH}$
		1 MHz		35	mA	
$I_{SB}$	Standby $V_{DD}$ Current			20	$\mu A$	$CE\#, RST\#=V_{DD}\pm 0.3V$
$I_{ALP}$	Auto Low Power $V_{DD}$ Current			20	$\mu A$	$CE\#=0.1V, V_{DD}=V_{DD} \text{ Max}$ $WE\#=V_{DD}-0.1V$ Address inputs= $0.1V$ or $V_{DD}-0.1V$
$I_{RT}$	Reset $V_{DD}$ Current			20	$\mu A$	$RST\#=GND$
$I_{LI}$	Input Leakage Current			1	$\mu A$	$V_{IN} = GND$ to $V_{DD}, V_{DD}=V_{DD} \text{ Max}$
$I_{LIW}$	Input Leakage Current on $WP\#$ pin and $RST\#$ pin			10	$\mu A$	$WP\#=GND$ to $V_{DD}, V_{DD}=V_{DD} \text{ Max}$ $RST\#=GND$ to $V_{DD}, V_{DD}=V_{DD} \text{ Max}$
$I_{LO}$	Output Leakage Current			1	$\mu A$	$V_{OUT} = GND$ to $V_{DD}, V_{DD}=V_{DD} \text{ Max}$
$V_{IL}$	Input Low Voltage			0.8	V	$V_{DD}=V_{DD} \text{ Min}$
$V_{ILC}$	Input Low Voltage (CMOS)			0.3	V	$V_{DD}=V_{DD} \text{ Max}$
$V_{IH}$	Input High Voltage	$0.7 V_{DD}$	$V_{DD}+0.3$		V	$V_{DD}=V_{DD} \text{ Max}$
$V_{IHC}$	Input High Voltage (CMOS)	$V_{DD}-0.3$	$V_{DD}+0.3$		V	$V_{DD}=V_{DD} \text{ Max}$
$V_{OL}$	Output Low Voltage			0.2	V	$I_{OL}=100 \mu A, V_{DD}=V_{DD} \text{ Min}$
$V_{OH}$	Output High Voltage	$V_{DD}-0.2$			V	$I_{OH}=-100 \mu A, V_{DD}=V_{DD} \text{ Min}$

T10.1 1274

1. Address input =  $V_{ILT}/V_{IHT}, V_{DD}=V_{DD} \text{ Max}$  (See Figure 22)

**TABLE 11: Recommended System Power-up Timings**

Symbol	Parameter	Minimum	Units
$T_{PU-READ}^1$	Power-up to Read Operation	100	$\mu s$
$T_{PU-WRITE}^1$	Power-up to Write Operation	100	$\mu s$

T11.0 1274

1. This parameter is measured only for initial qualification and after a design or process change that could affect this parameter.

**TABLE 12: Capacitance ( $T_A = 25^\circ C, f=1 \text{ Mhz, other pins open}$ )**

Parameter	Description	Test Condition	Maximum
$C_{I/O}^1$	I/O Pin Capacitance	$V_{I/O} = 0V$	10 pF
$C_{IN}^1$	Input Capacitance	$V_{IN} = 0V$	10 pF

T12.0 1274

1. This parameter is measured only for initial qualification and after a design or process change that could affect this parameter.

**TABLE 13: Reliability Characteristics**

Symbol	Parameter	Minimum Specification	Units	Test Method
$N_{END}^1$	Endurance	10,000	Cycles	JEDEC Standard A117
$T_{DR}^1$	Data Retention	100	Years	JEDEC Standard A103
$I_{LTH}^1$	Latch Up	$100 + I_{DD}$	mA	JEDEC Standard 78

T13.0 1274

1. This parameter is measured only for initial qualification and after a design or process change that could affect this parameter.

**AC CHARACTERISTICS**

**TABLE 14: Read Cycle Timing Parameters  $V_{DD} = 2.7-3.6V$**

Symbol	Parameter	Min	Max	Units
$T_{RC}$	Read Cycle Time	70		ns
$T_{CE}$	Chip Enable Access Time		70	ns
$T_{AA}$	Address Access Time		70	ns
$T_{OE}$	Output Enable Access Time		30	ns
$T_{CLZ}^1$	CE# Low to Active Output	0		ns
$T_{OLZ}^1$	OE# Low to Active Output	0		ns
$T_{CHZ}^1$	CE# High to High-Z Output		16	ns
$T_{OHZ}^1$	OE# High to High-Z Output		16	ns
$T_{OH}^1$	Output Hold from Address Change	0		ns
$T_{RP}^1$	RST# Pulse Width	500		ns
$T_{RHR}^1$	RST# High before Read	50		ns
$T_{RY}^{1,2}$	RST# Pin Low to Read Mode		20	$\mu s$

T14.1 1274

1. This parameter is measured only for initial qualification and after a design or process change that could affect this parameter.
2. This parameter applies to Sector-Erase, Block-Erase, and Program operations.  
This parameter does not apply to Chip-Erase operations.

**TABLE 15: Program/Erase Cycle Timing Parameters**

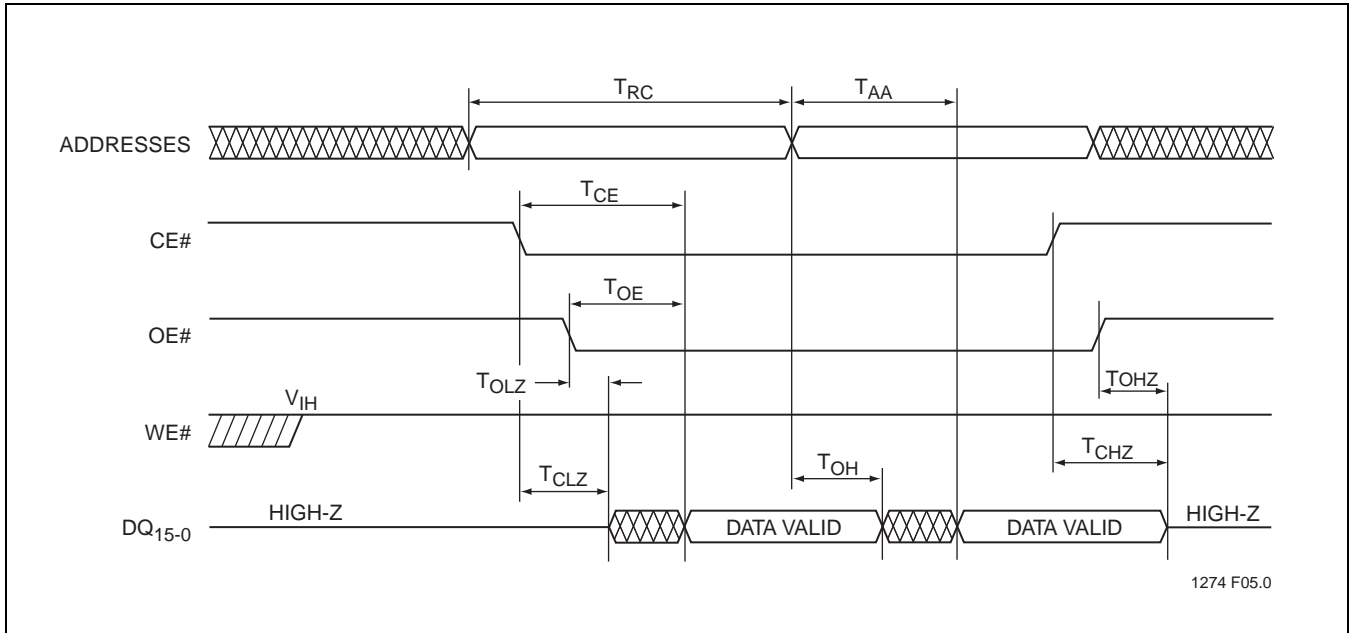
Symbol	Parameter	Min	Max	Units
$T_{BP}$	Program Time		10	$\mu s$
$T_{AS}$	Address Setup Time	0		ns
$T_{AH}$	Address Hold Time	40		ns
$T_{CS}$	WE# and CE# Setup Time	0		ns
$T_{CH}$	WE# and CE# Hold Time	0		ns
$T_{OES}$	OE# High Setup Time	0		ns
$T_{OEH}$	OE# High Hold Time	10		ns
$T_{CP}$	CE# Pulse Width	40		ns
$T_{WP}$	WE# Pulse Width	40		ns
$T_{WPH}^1$	WE# Pulse Width High	30		ns
$T_{CPH}^1$	CE# Pulse Width High	30		ns
$T_{DS}$	Data Setup Time	30		ns
$T_{DH}^1$	Data Hold Time	0		ns
$T_{IDA}^1$	Software ID Access and Exit Time		150	ns
$T_{SE}$	Sector-Erase		25	ms
$T_{BE}$	Block-Erase		25	ms
$T_{SCE}$	Chip-Erase		50	ms
$T_{ES}$	Erase-Suspend Latency		10	$\mu s$
$T_{BY}^{1,2}$	RY/BY# Delay Time		90	ns
$T_{BR}^1$	Bus Recovery Time		0	$\mu s$

T15.1 1274

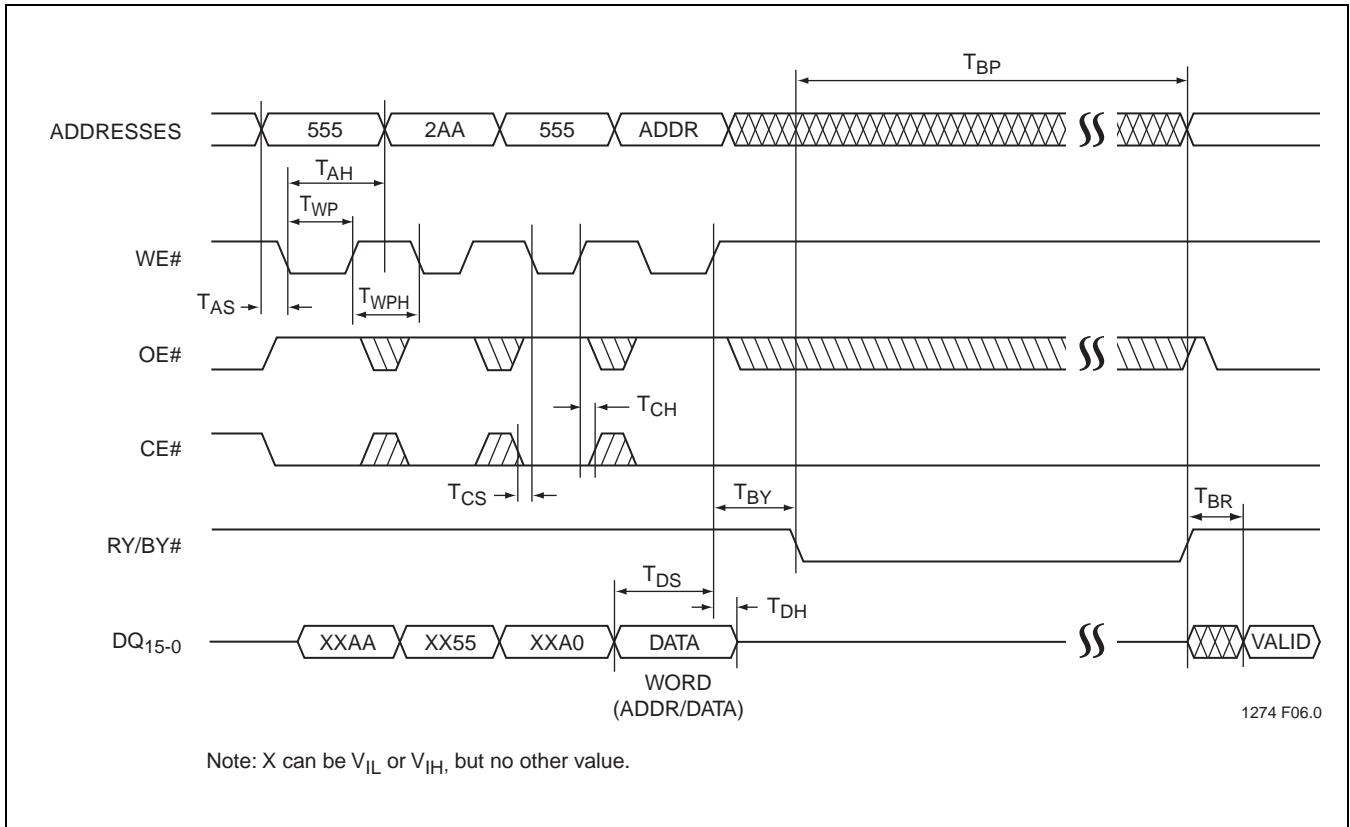
1. This parameter is measured only for initial qualification and after a design or process change that could affect this parameter.

## Data Sheet

- This parameter applies to Sector-Erase, Block-Erase, and Program operations.  
This parameter does not apply to Chip-Erase operations.

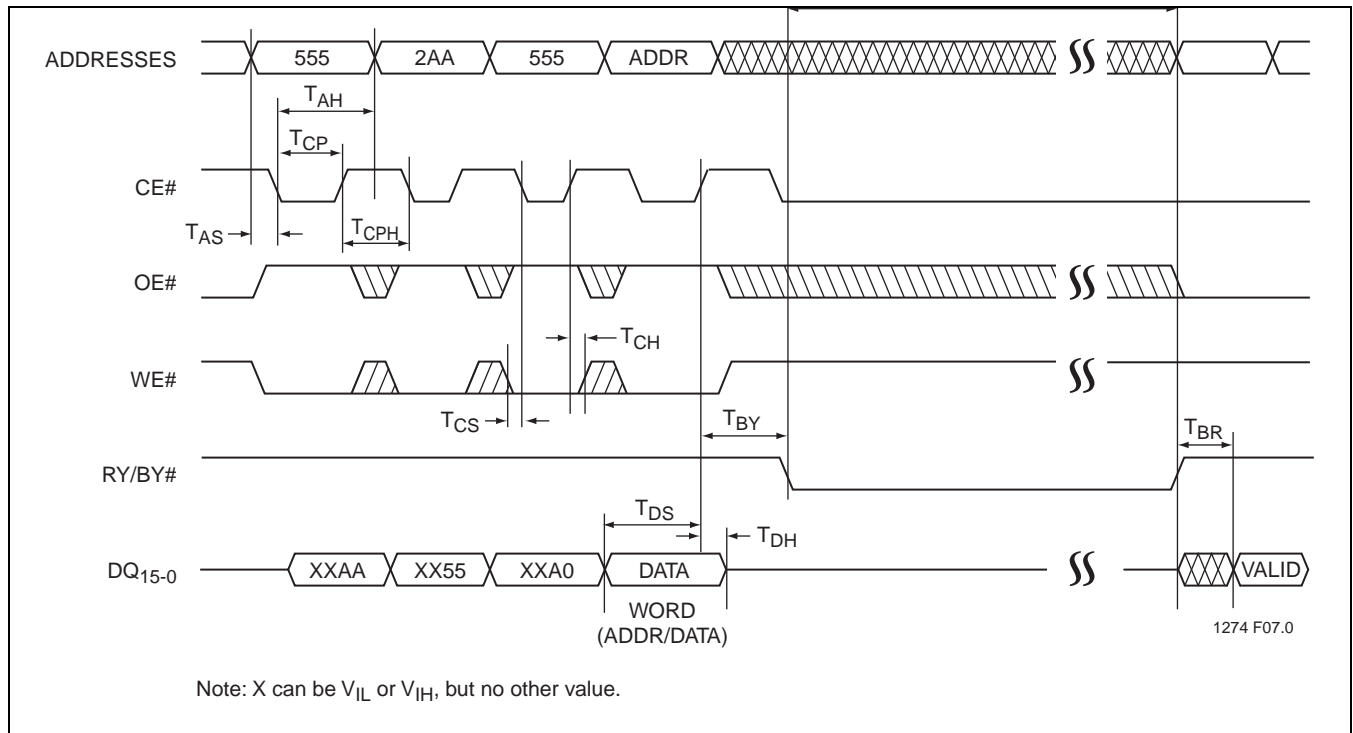
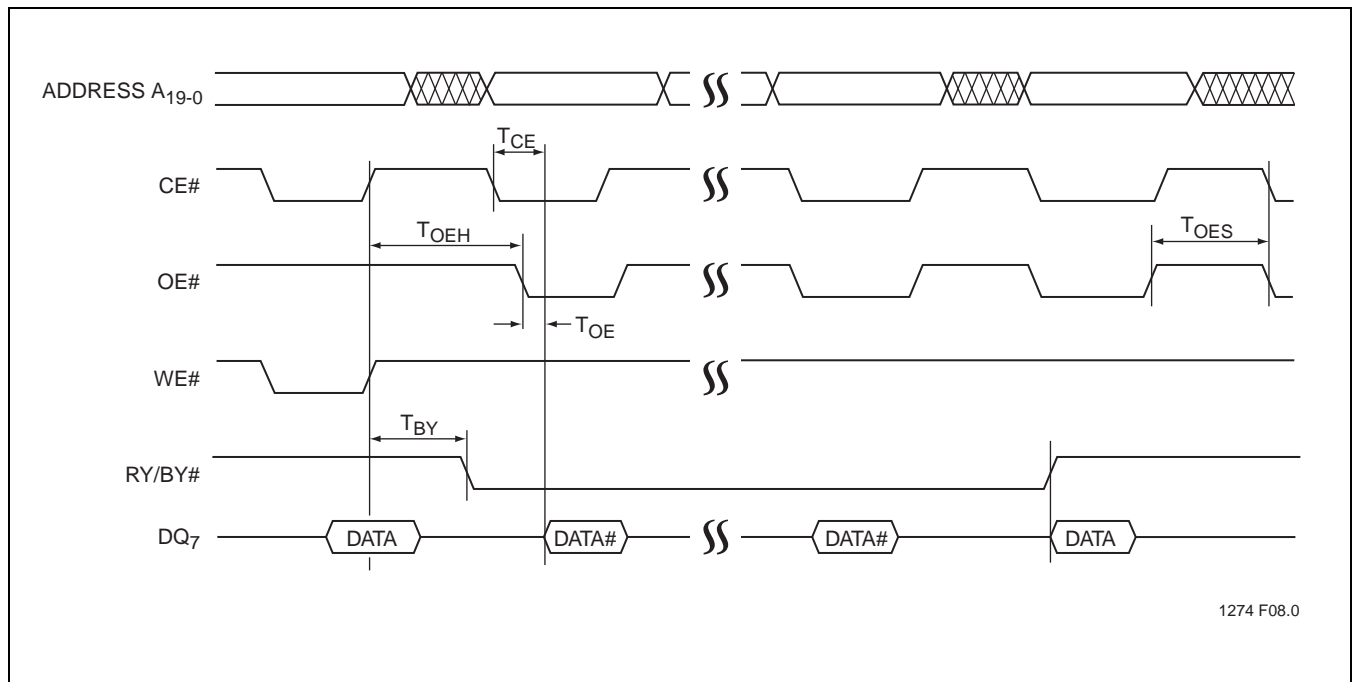


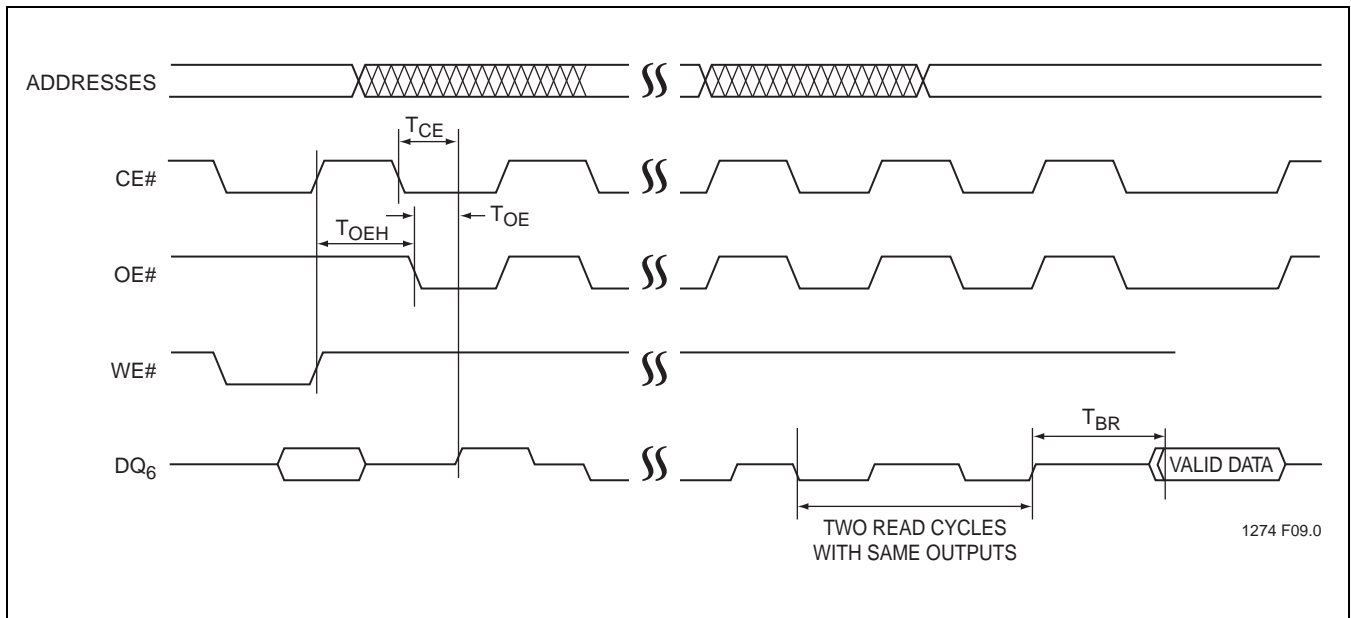
**FIGURE 8: Read Cycle Timing Diagram**



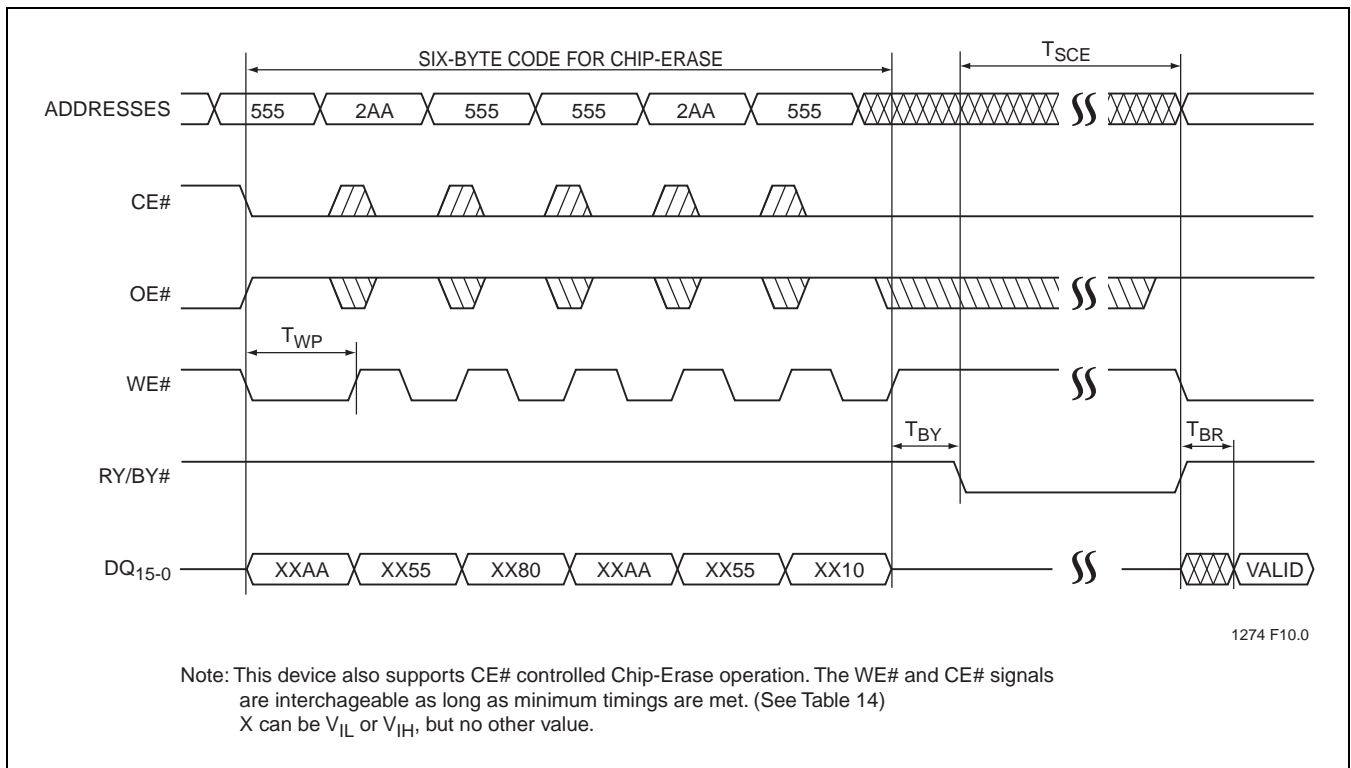
**FIGURE 9: WE# Controlled Program Cycle Timing Diagram**

## Data Sheet


**FIGURE 10: CE# Controlled Program Cycle Timing Diagram**

**FIGURE 11: Data# Polling Timing Diagram**

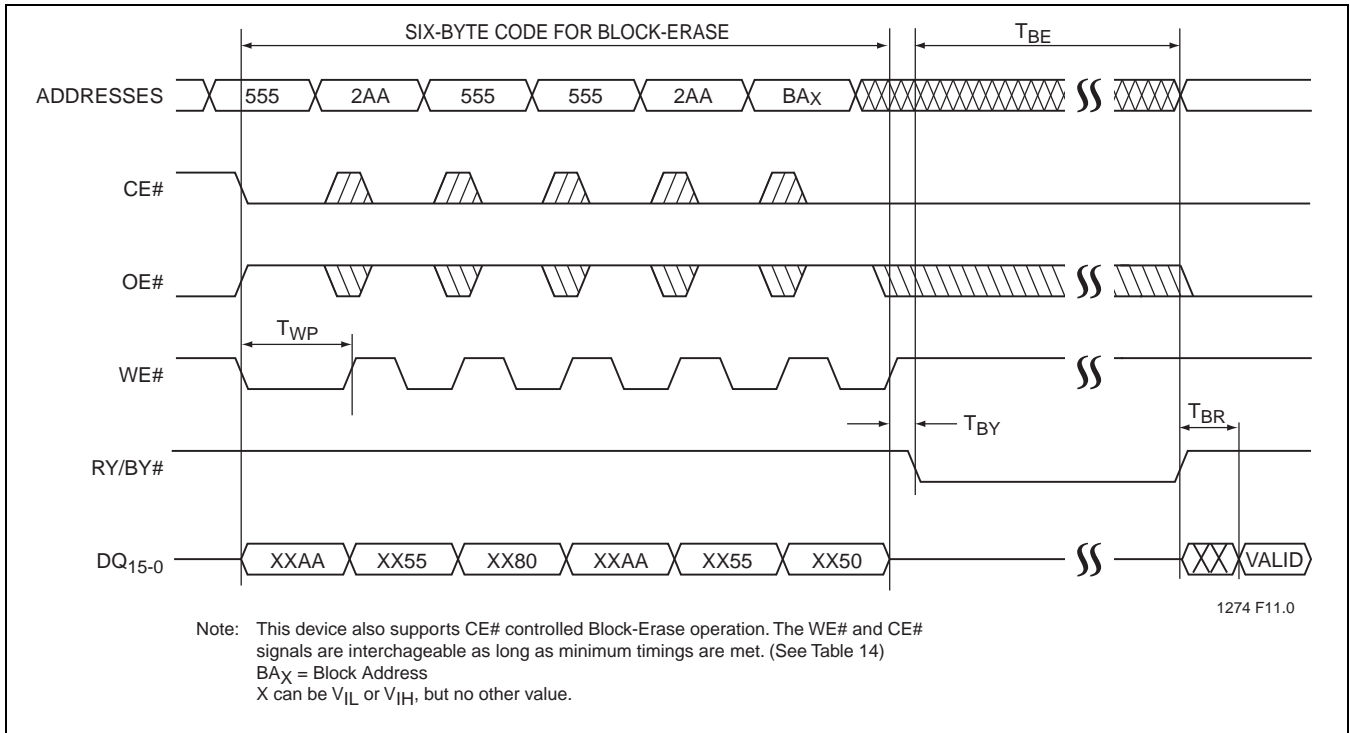
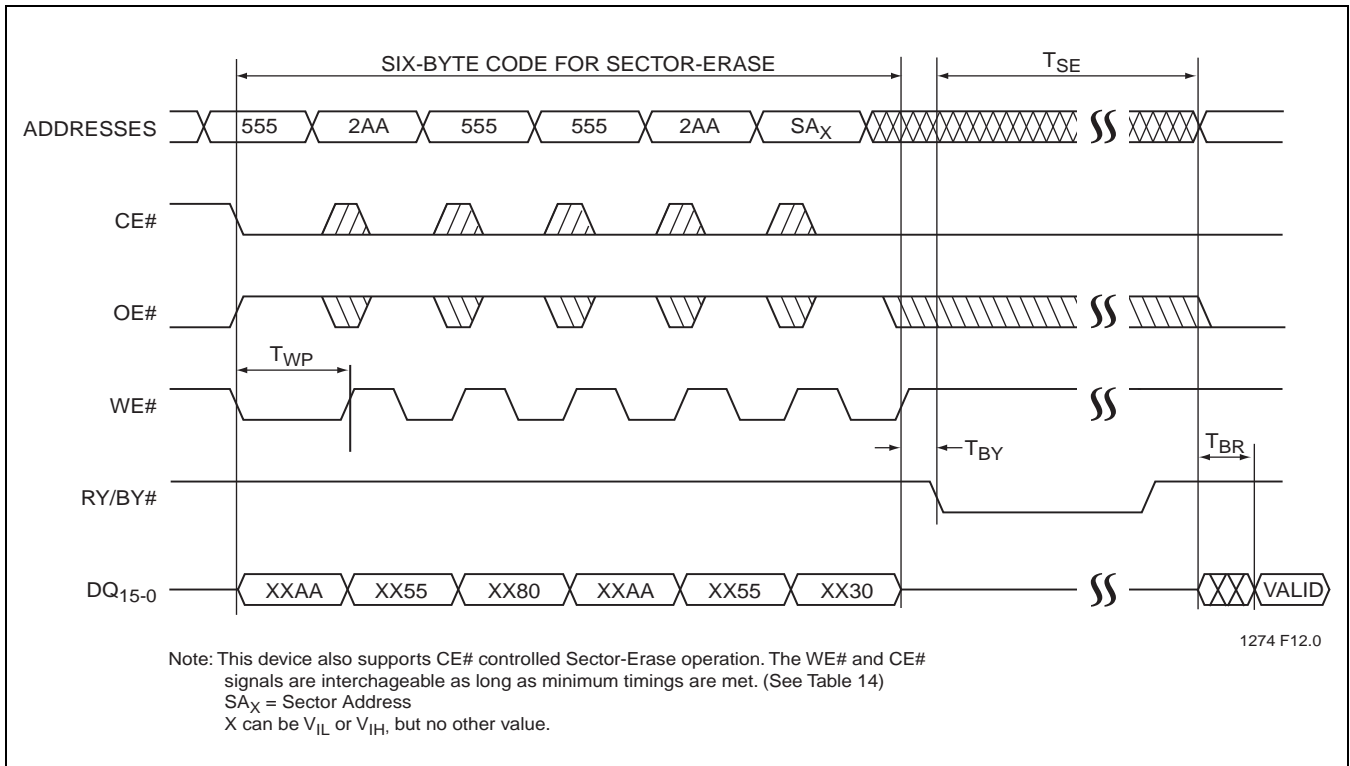


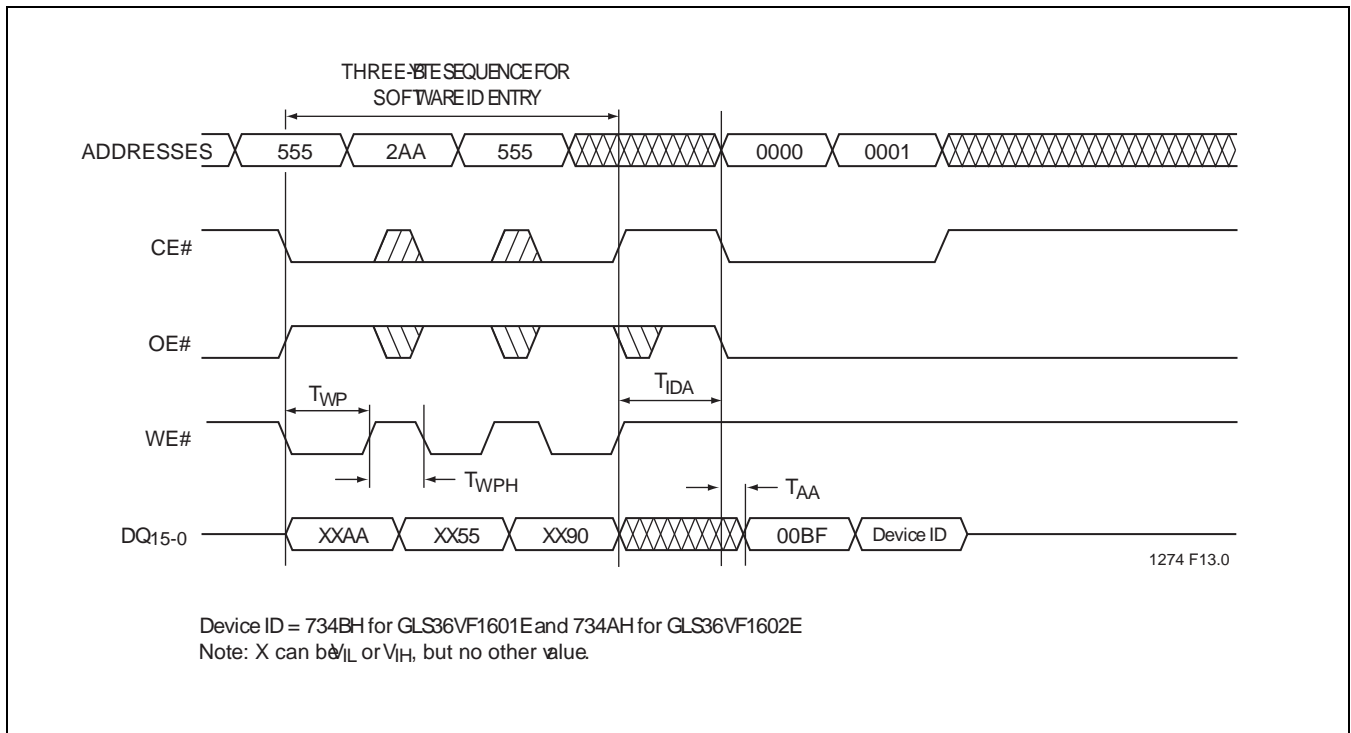
**FIGURE 12: Toggle Bit Timing Diagram**



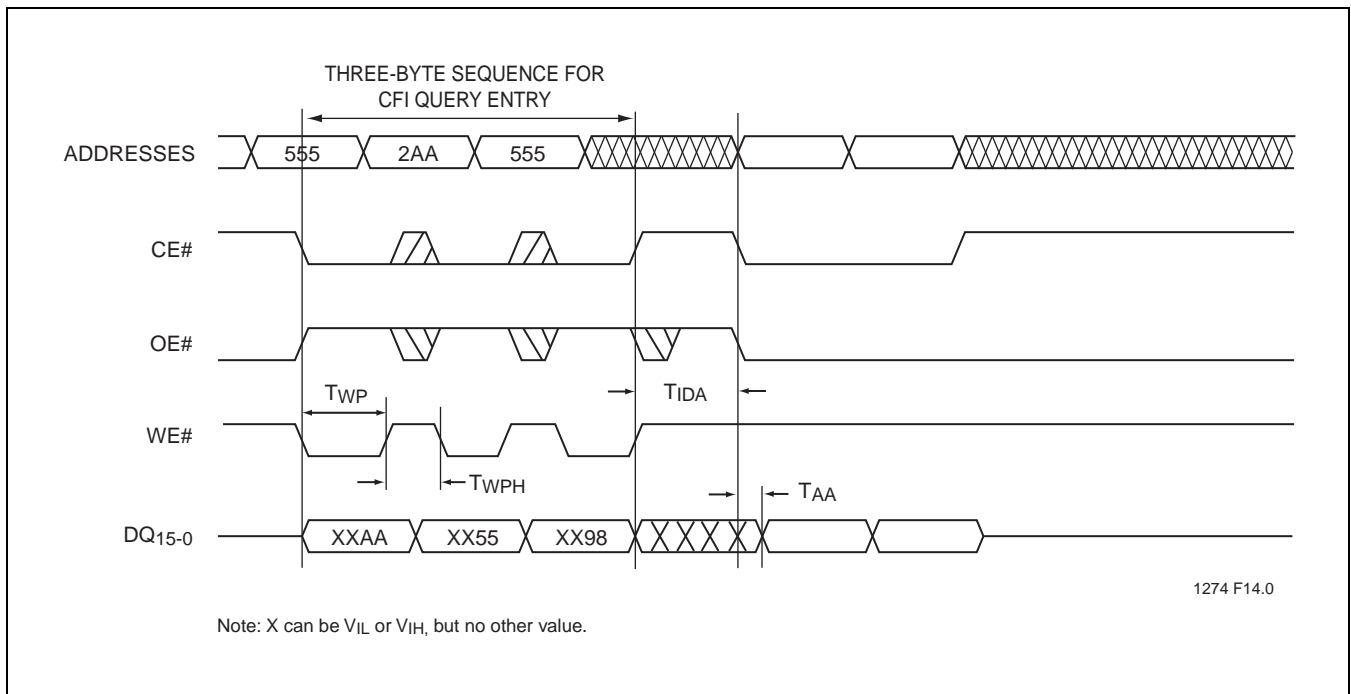
**FIGURE 13: WE# Controlled Chip-Erase Timing Diagram**

## Data Sheet


**FIGURE 14: WE# Controlled Block-Erase Timing Diagram**

**FIGURE 15: WE# Controlled Sector-Erase Timing Diagram**

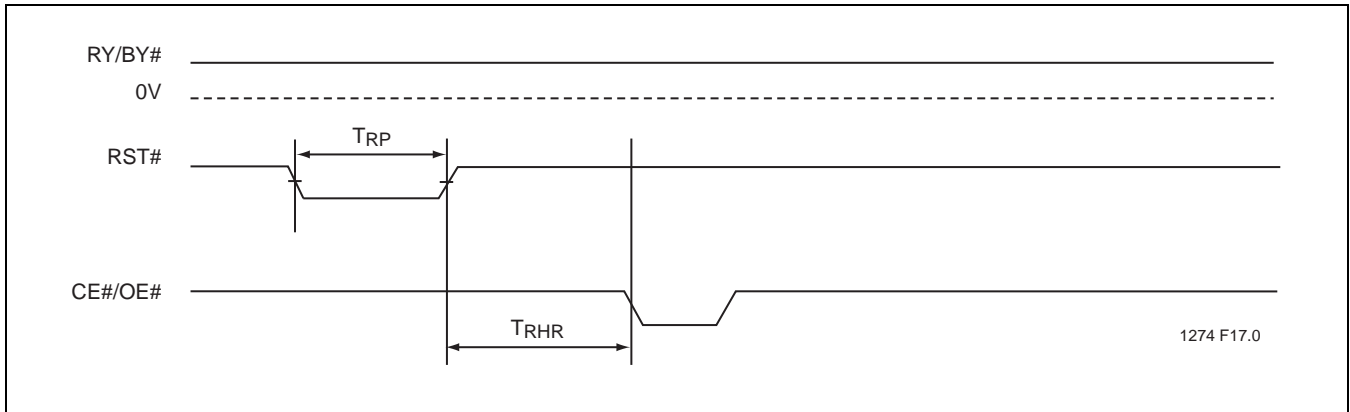


**FIGURE 16: Software ID Entry and Read**

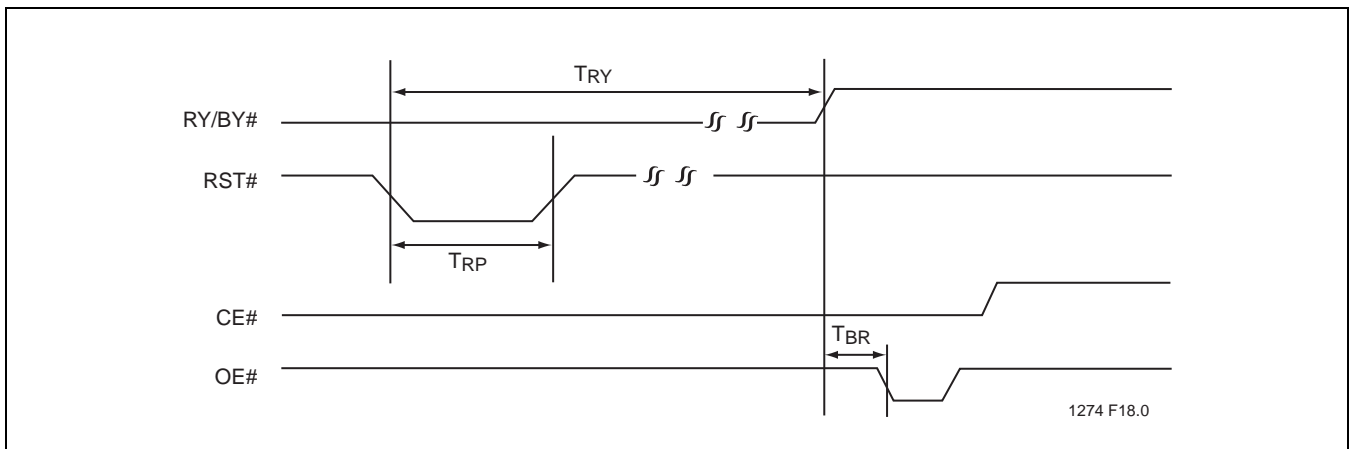


**FIGURE 17: CFI Entry and Read**



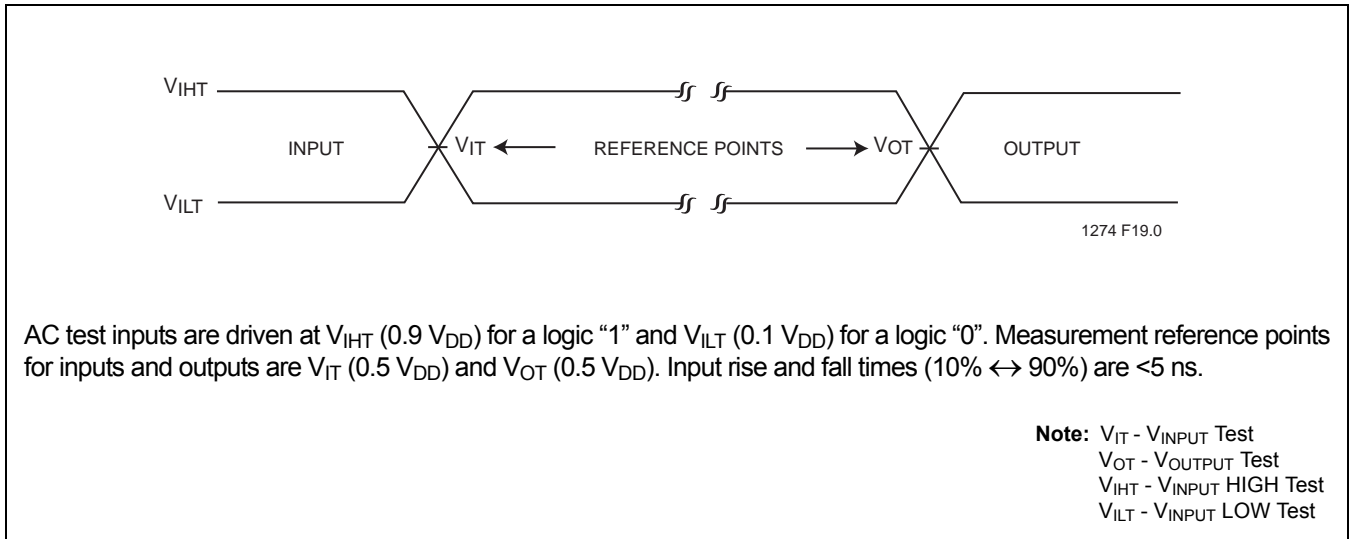


**FIGURE 20: RST# Timing Diagram (When no internal operation is in progress)**

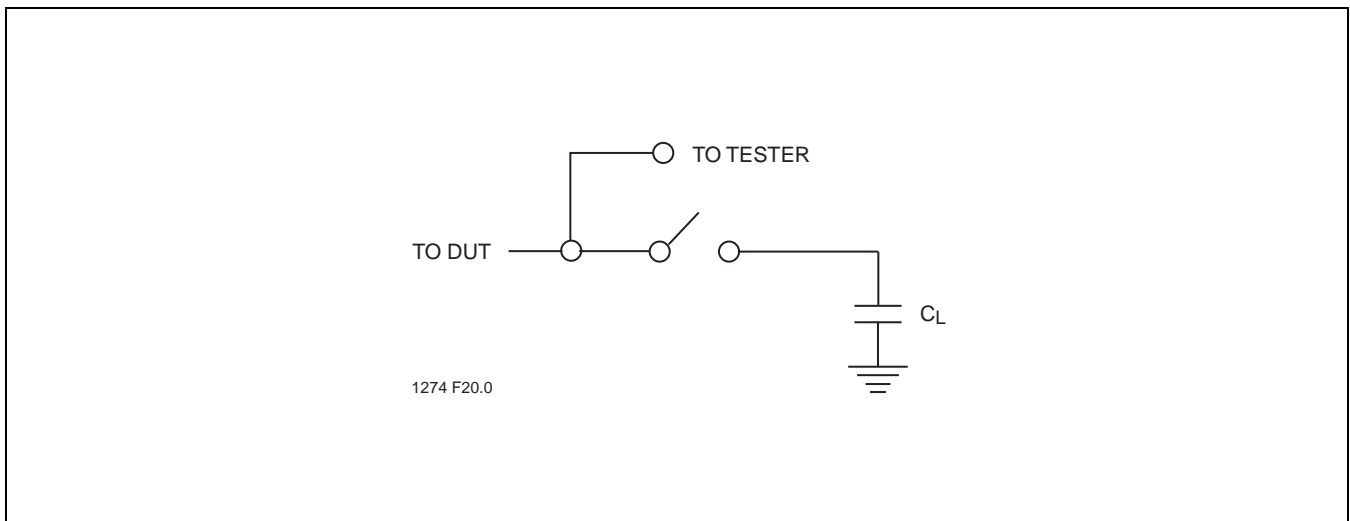


**FIGURE 21: RST# Timing Diagram (During Sector- or Block-Erase operation)**

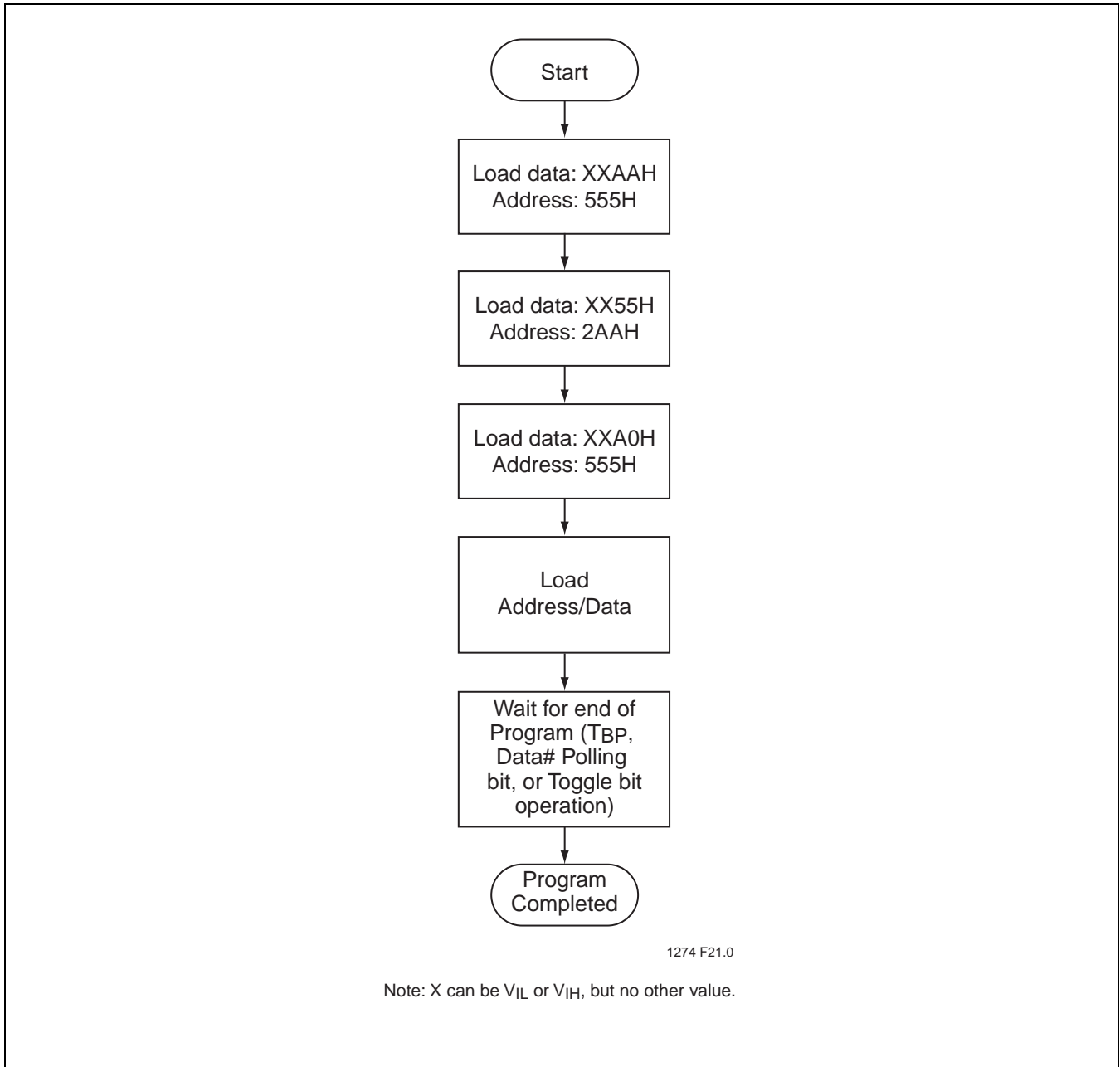
Data Sheet



**FIGURE 22: AC Input/Output Reference Waveforms**

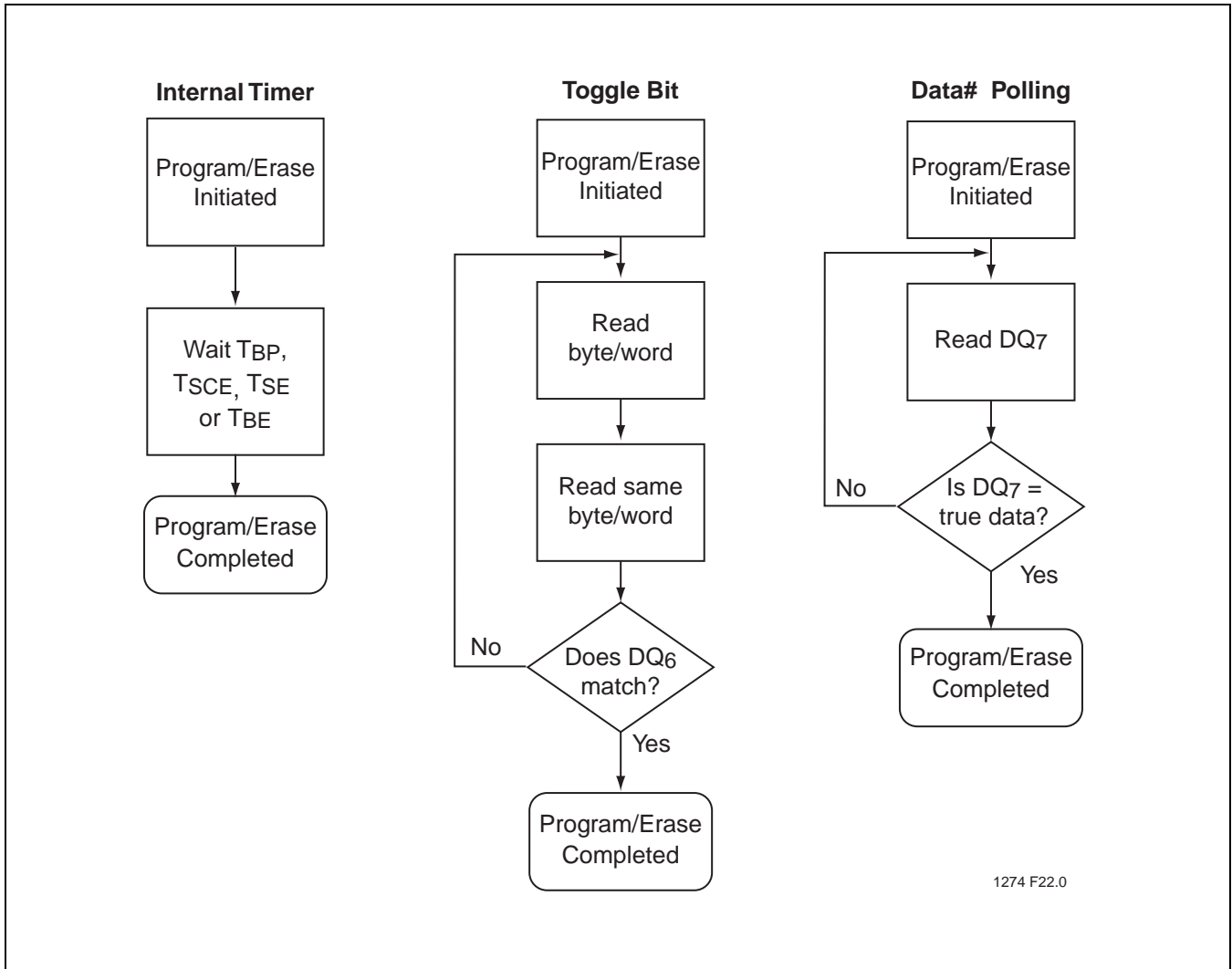


**FIGURE 23: A Test Load Example**

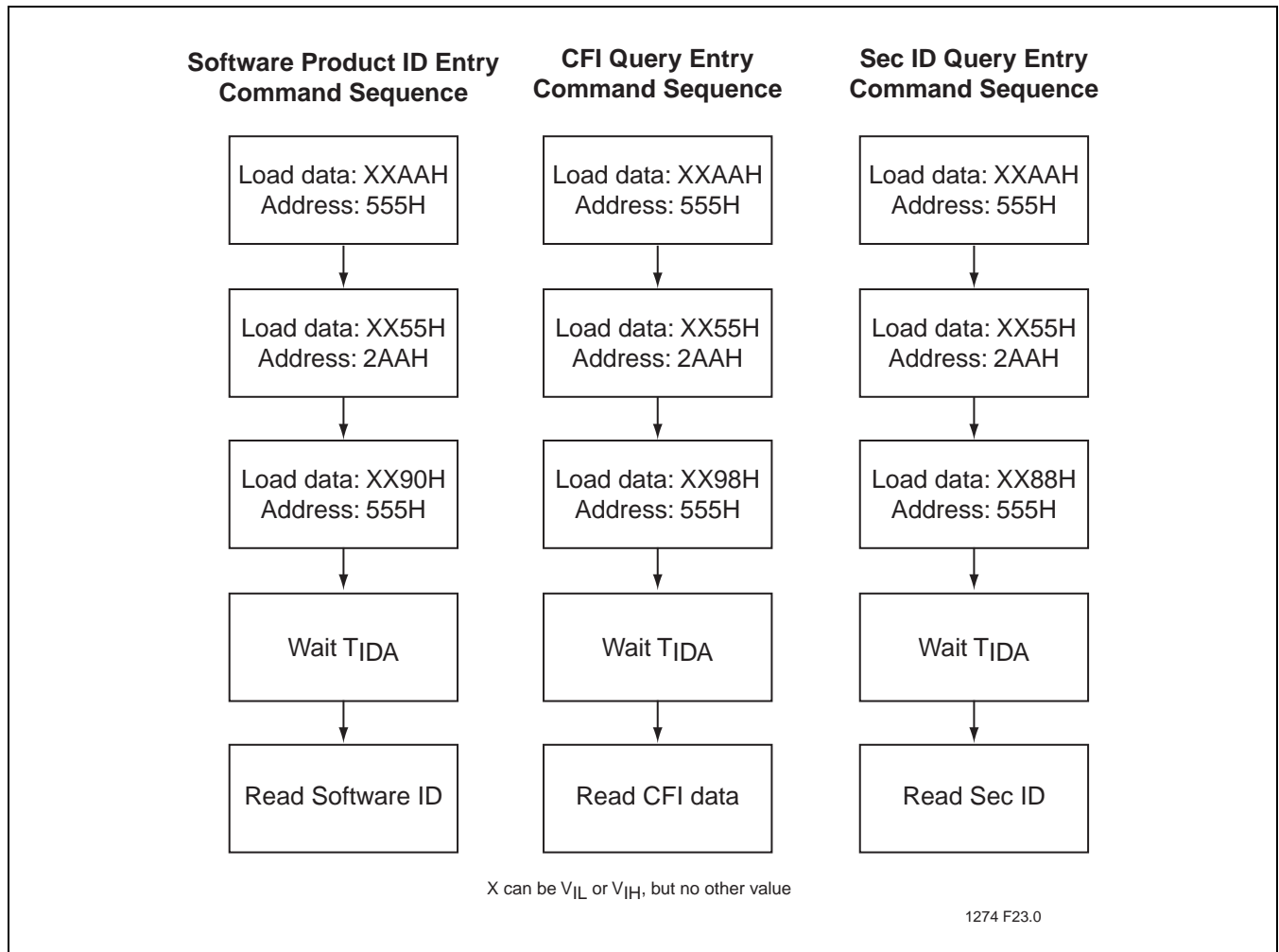


**FIGURE 24: Program Algorithm**

Data Sheet

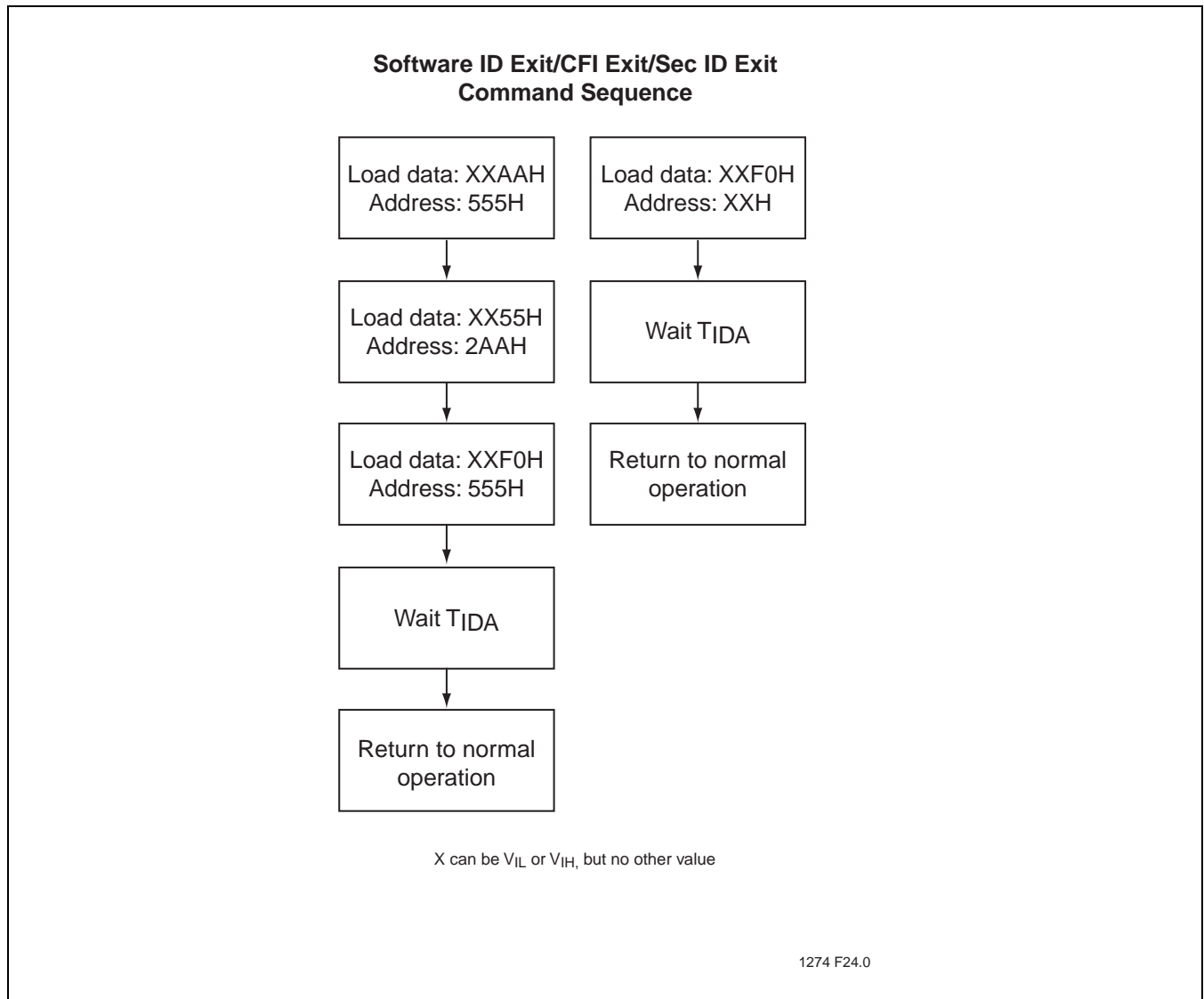


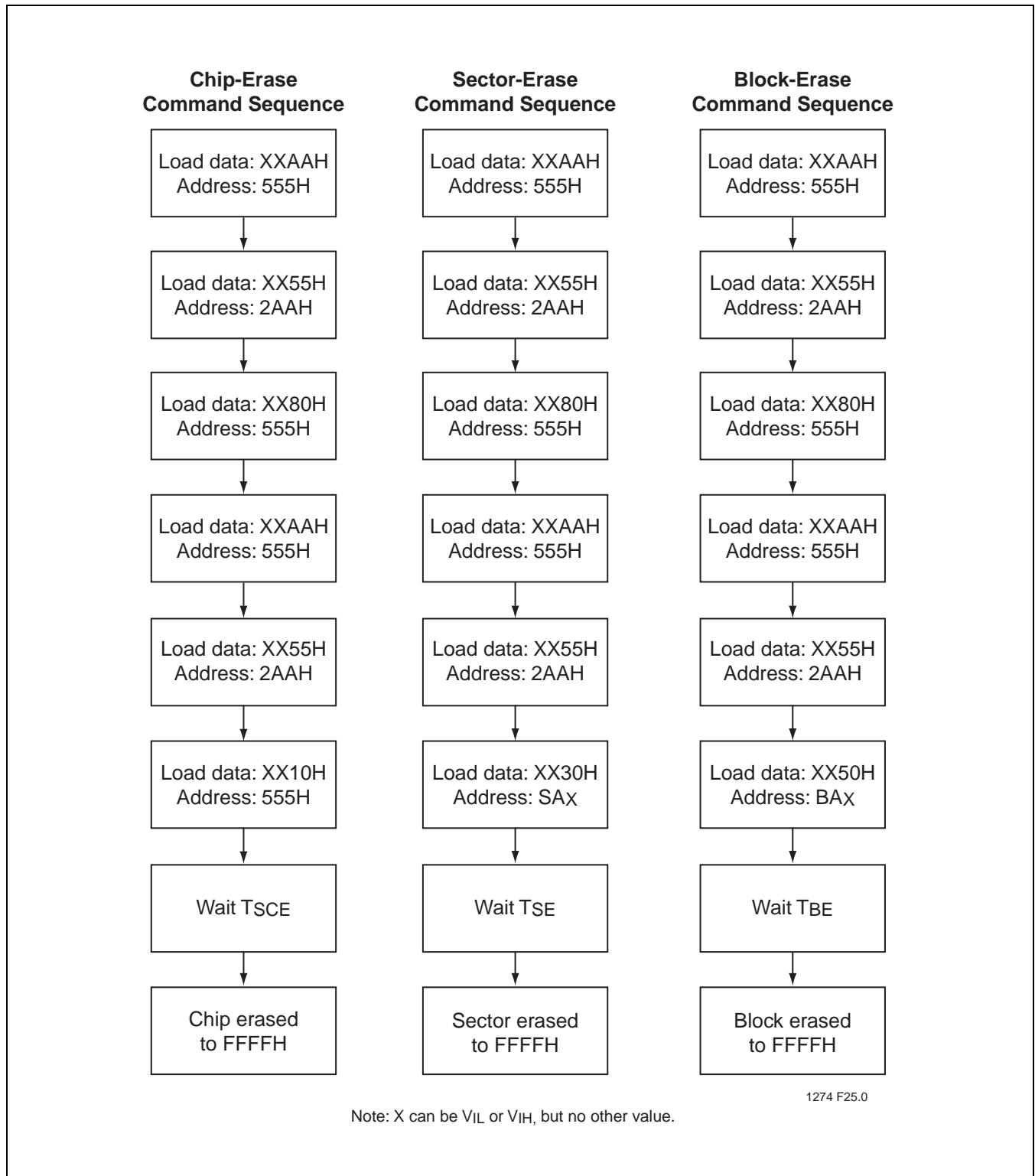
**FIGURE 25: Wait Options**



**FIGURE 26: Software Product ID/CFI/Sec ID Entry Command Flowcharts**

## Data Sheet

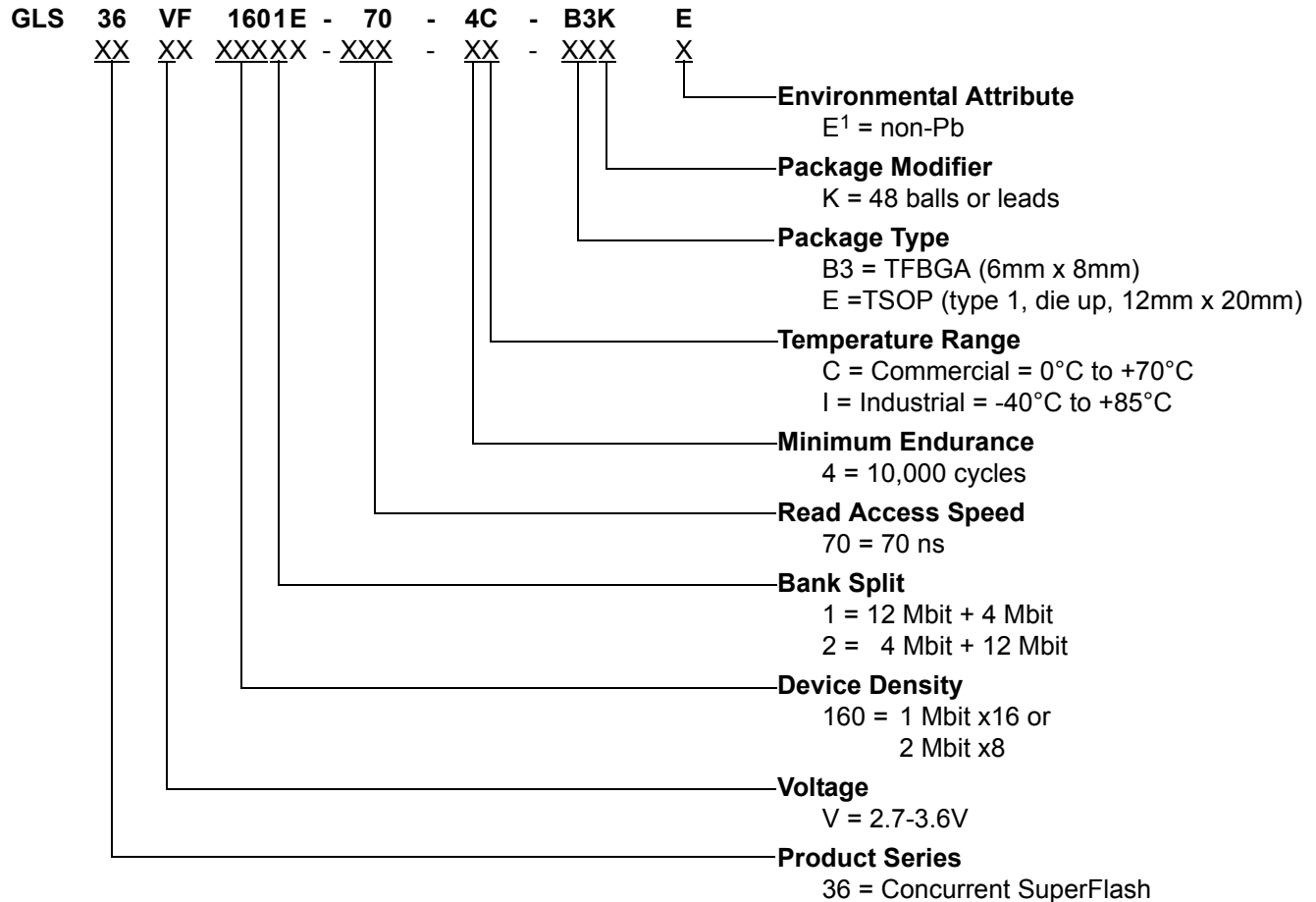

**FIGURE 27: Software Product ID/CFI/Sec ID Exit Command Flowcharts**



**FIGURE 28: Erase Command Sequence**

Data Sheet

## PRODUCT ORDERING INFORMATION



1. Environmental suffix "E" denotes non-Pb solder. Greenliant non-Pb solder devices are "RoHS Compliant".

### Valid combinations for GLS36VF1601E

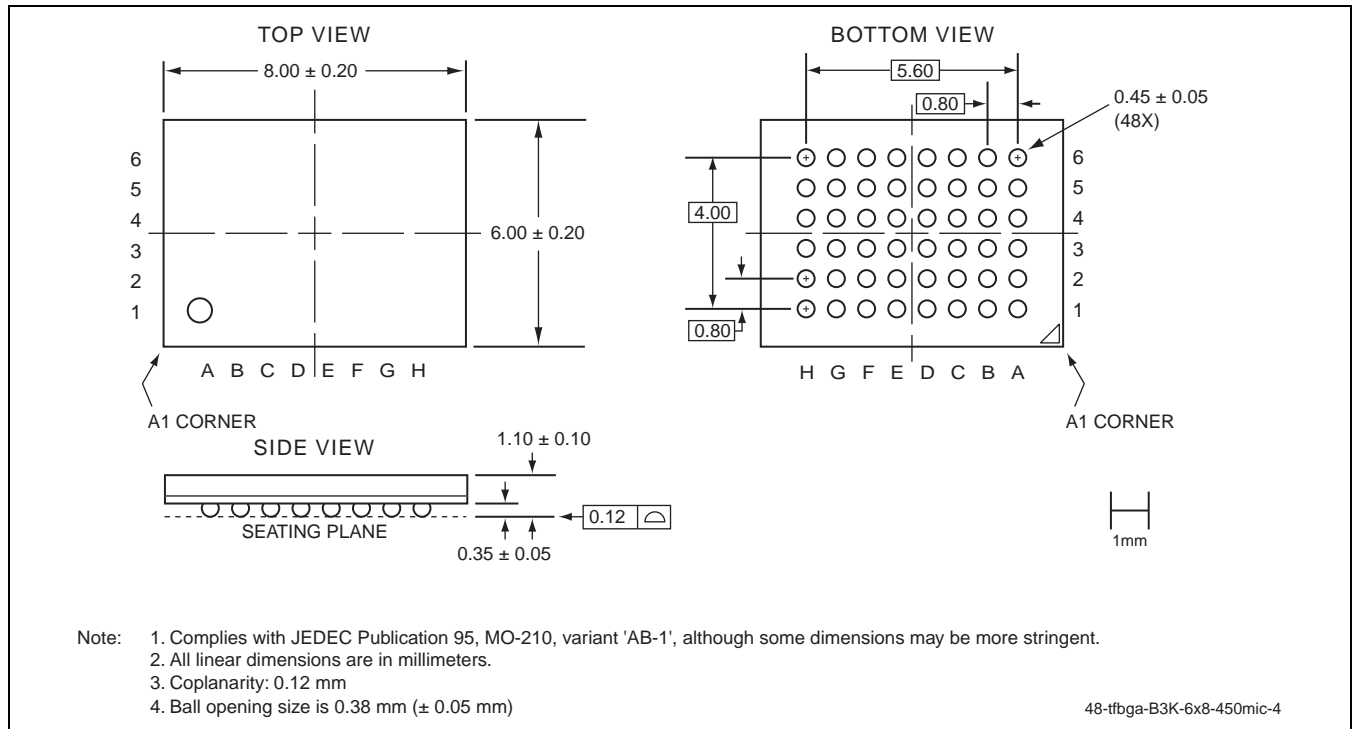
GLS36VF1601E-70-4C-B3KE    GLS36VF1601E-70-4C-EKE  
 GLS36VF1601E-70-4I-B3KE    GLS36VF1601E-70-4I-EKE

### Valid combinations for GLS36VF1602E

GLS36VF1602E-70-4C-B3KE    GLS36VF1602E-70-4C-EKE  
 GLS36VF1602E-70-4I-B3KE    GLS36VF1602E-70-4I-EKE

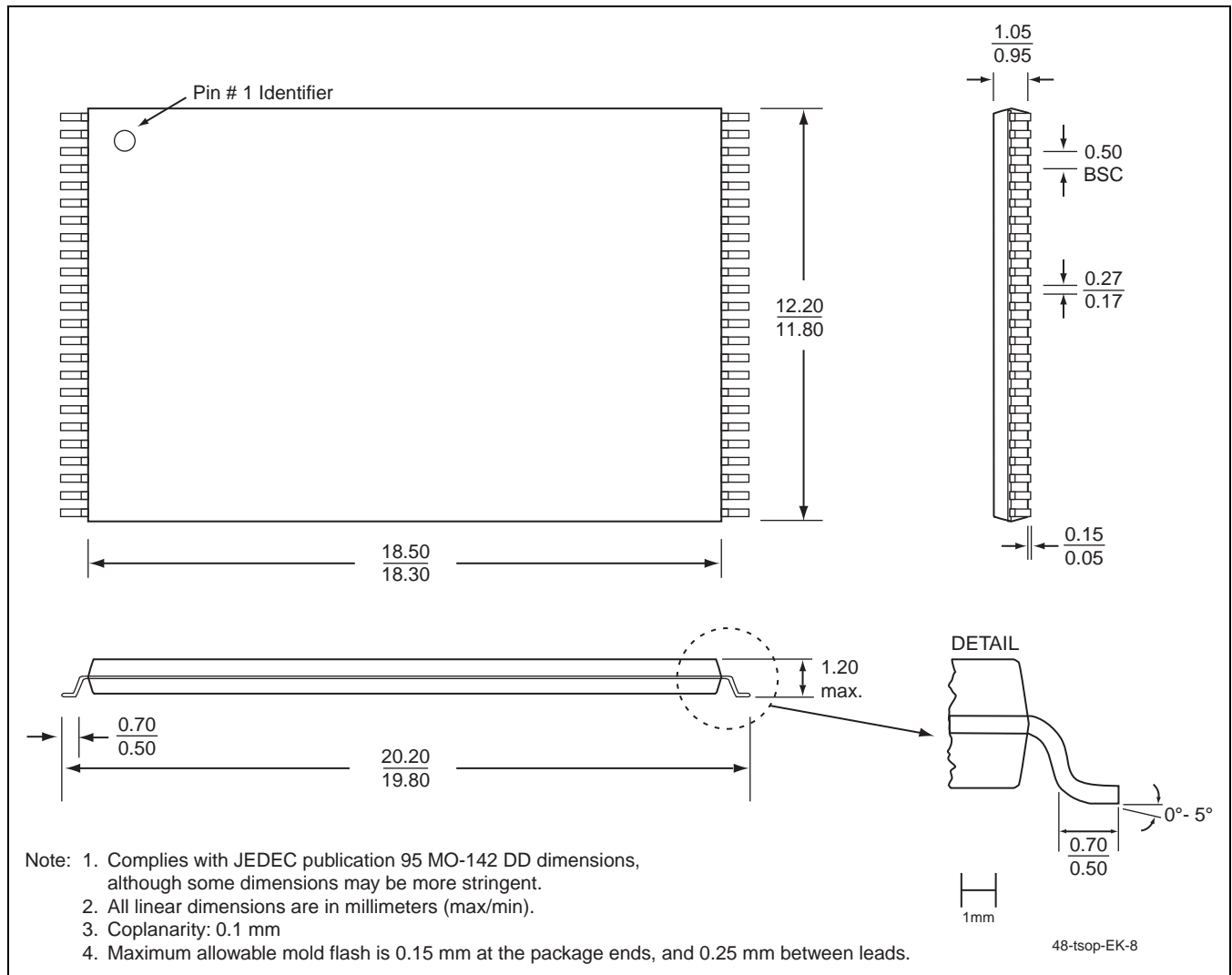
**Note:** Valid combinations are those products in mass production or will be in mass production. Consult your Greenliant sales representative to confirm availability of valid combinations and to determine availability of new combinations.

**PACKAGING DIAGRAMS**



**FIGURE 29: 48-ball Thin-profile, Fine-pitch Ball Grid Array (TFBGA) 6mm x 8mm  
 Greenliant Package Code: B3K**

## Data Sheet



**FIGURE 30: 48-lead Thin Small Outline Package (TSOP) 12mm x 20mm**  
**Greenliant Package Code: EK**

+

**TABLE 16: Revision History**

<b>Number</b>	<b>Description</b>	<b>Date</b>
00	<ul style="list-style-type: none"> <li>Initial release of data sheet</li> </ul>	Oct 2004
01	<ul style="list-style-type: none"> <li>Updates to data sheet Tables 1, 4, 5, 8, 9, and 13. Added RoHS compliance information on page 1 and in the “Product Ordering Information” on page 34</li> <li>Updated sector information in Table 9, “Device Geometry Information” on page 16</li> <li>Updated Active Current values and test conditions in Table 10 on page 18</li> <li>Updated OE timings in Table 14 on page 19</li> <li>Added a Reset footnote to Table 5 on page 13</li> <li>Updated the footnote for Table 2 on page 5</li> <li>Corrected the Address Format in footnote 1 in Table 6 on page 14</li> <li>Clarified the solder temperature profile under “Absolute Maximum Stress Ratings” on page 17</li> </ul>	Mar 2005
02	<ul style="list-style-type: none"> <li>Updated “Erase-Suspend/Erase-Resume Operations” on page 4</li> <li>Updated T<sub>ES</sub> parameter from 20 μs to 10 μs in Table 15 on page 19</li> </ul>	Jul 2005
03	<ul style="list-style-type: none"> <li>Made changes to support Pb-free packages only</li> </ul>	Nov 2005
04	<ul style="list-style-type: none"> <li>Edited T<sub>by</sub> TY/BY# Delay Time in Table 15 on page 19 from 90ns Min to 90ns Max</li> </ul>	Nov 2009
05	<ul style="list-style-type: none"> <li>Transferred from SST to Greenliant</li> </ul>	May 2010

© 2010 Greenliant Systems, Ltd. All rights reserved. Greenliant, the Greenliant logo and NANDrive are trademarks of Greenliant Systems, Ltd. All trademarks and registered trademarks are the property of their respective owners. These specifications are subject to change without notice. CSF is a trademark and SuperFlash is a registered trademark of Silicon Storage Technology, Inc., a wholly owned subsidiary of Microchip Technology Inc.

# Mouser Electronics

Authorized Distributor

Click to View Pricing, Inventory, Delivery & Lifecycle Information:

## Greenliant:

[SST36VF1601G-70-4I-L1PE](#) [SST36VF1601E-70-4C-EKE](#) [SST36VF1601G-70-4I-EKE](#) [SST36VF1602E-70-4C-B3KE](#)  
[SST36VF1601E-70-4C-B3KE-T](#) [SST36VF1601E-70-4C-B3KE](#) [SST36VF1602E-70-4I-EKE](#) [SST36VF1601E-70-4I-](#)  
[EKE](#) [SST36VF1602E-70-4C-EKE](#) [SST36VF1602E-70-4I-B3KE](#) [SST36VF1601E-70-4I-B3KE](#) [SST36VF1601G-70-4I-](#)  
[B3KE](#)

## Looking for pricing, stock, or lifecycle information?

Click below to explore more details on WIN SOURCE:

 [View SST36VF1601G-70-4I-EKE on WIN SOURCE](#)

 [Greenliant Information](#)

## Optimize Your Supply Chain with WIN SOURCE Solutions

-  Global Sourcing Solution
-  Obsolete Management
-  Cost Control Management
-  Shortage Management
-  Alternative Solution
-  Excess Inventory Management