



# THE DATASHEET OF PA04A



## *Power Operational Amplifier*

**RoHS**  
COMPLIANT

### FEATURES

- High Internal Dissipation — 200 Watts
- High Voltage, High Current — 200V, 20A
- High Slew Rate — 50V/ $\mu$ s
- 4 Wire Current Limit Sensing
- Low Distortion
- External Sleep Mode Control
- Optional Boost Voltage Inputs
- Evaluation Kit — See EK45



### APPLICATIONS

- Sonar Transducer Driver
- Linear and Rotary Motor Drives
- Yoke/Magnetic Field Excitation
- Programmable Power Supplies to  $\pm 95$ V
- Audio up to 400W

### DESCRIPTION

The PA04 is a high voltage MOSFET power operational amplifier that extends the performance limits of power amplifiers in slew rate and power bandwidth, while maintaining high current and power dissipation ratings.

The PA04 is a highly flexible amplifier. The sleep mode feature allows ultra-low quiescent current for standby operation or load protection by disabling the entire amplifier. Boost voltage inputs allow the small signal portion of the amplifier to operate at a higher voltage than the high current output stage. The amplifier is then biased to achieve close linear swings to the supply rails at high currents for extra efficient operation. External compensation tailors performance to user needs. A four wire sense technique allows precision current limiting without the need to consider internal or external m $\Omega$  parasitic resistance in the output line. The JEDEC MO-127 12-pin Power Dip™ package (see Package Outlines) is hermetically sealed and isolated from the internal circuits. The use of compressible thermal washers will void product warranty.

Figure 1: Equivalent Schematic

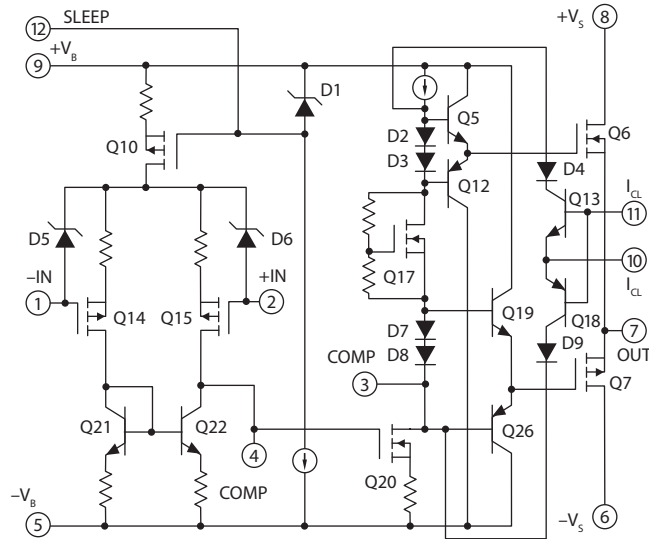

TYPICAL CONNECTION

Figure 2: Typical Connection

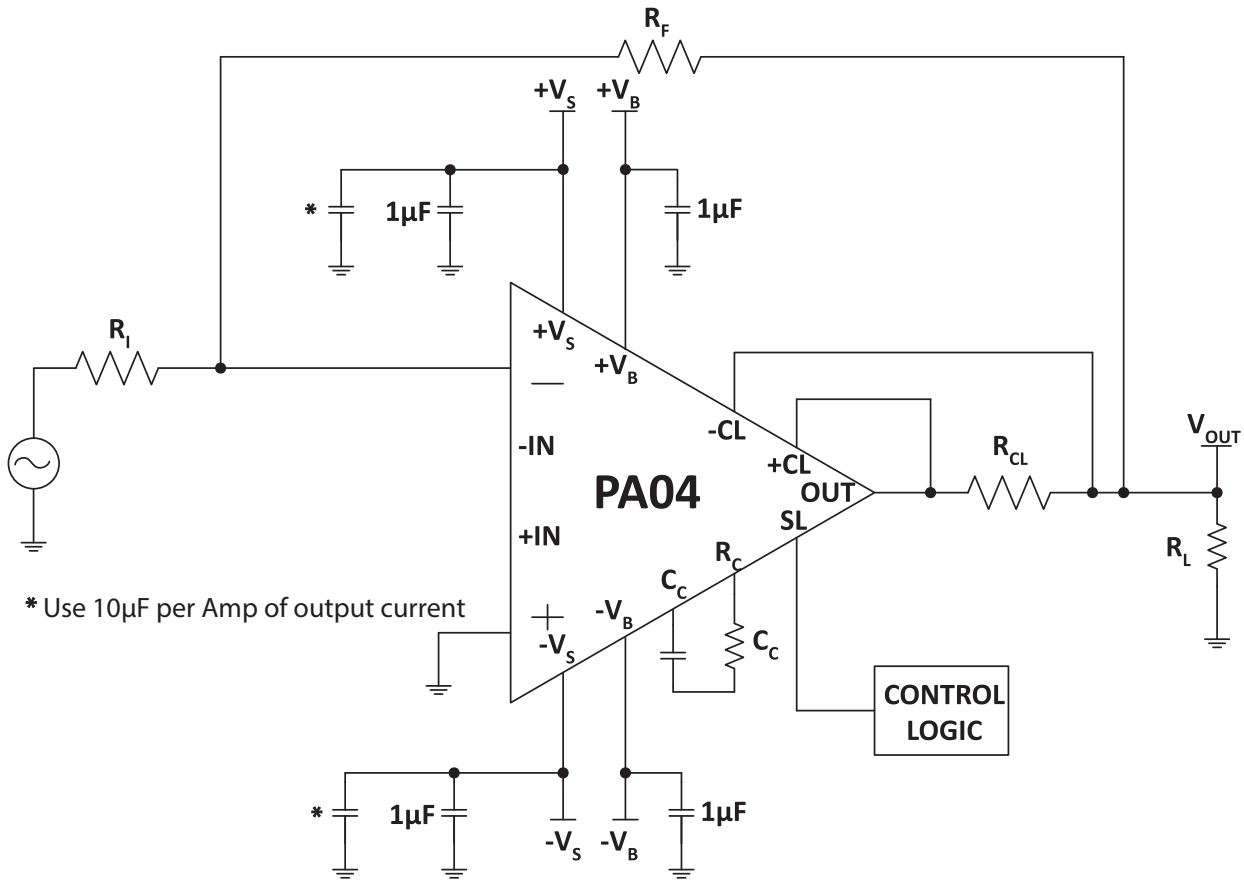

**PINOUT AND DESCRIPTION TABLE**

**Figure 3: External Connections**

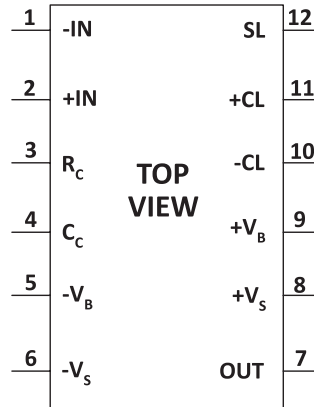

Pin Number	Name	Description
1	-IN	The inverting input.
2	+IN	The non-inverting input.
3	$R_C$	Compensation resistor connection. Select value based on Phase Compensation. See applicable section.
4	$C_C$	Compensation capacitor connection. Select value based on Phase Compensation. See applicable section.
5	$-V_B$	The negative boost supply rail. Short to $-V_S$ if unused. See applicable section.
6	$-V_S$	The negative supply rail.
7	OUT	The output. Connect this pin to load and to the feedback resistors through $R_{CL}$ .
8	$+V_S$	The positive supply rail.
9	$+V_B$	The positive boost supply rail. Short to $+V_S$ if unused. See applicable section.
10	-CL	Connect to the load side of the current limit resistor. Current limit will activate as the voltage across $R_{CL}$ increases.
11	+CL	Connect to the OUT side of the current limit resistor. Current limit will activate as the voltage across $R_{CL}$ increases.
12	SL	The sleep mode activation pin. See applicable section.

## SPECIFICATIONS

Unless otherwise noted:  $T_C = 25^\circ\text{C}$ ,  $C_C = 470\text{pF}$ ,  $R_C = 120\ \Omega$ . DC input specifications are  $\pm$  value given. Power supply voltage is typical rating.  $\pm V_B = \pm V_S$ .

### ABSOLUTE MAXIMUM RATINGS

Parameter	Symbol	Min	Max	Units
Supply Voltage, total	$+V_S$ to $-V_S$		200	V
Boost Voltage	$\pm V_B$		$\pm V_S \pm 20V$	V
Output Current, within SOA	$I_{OUT}$		20	A
Power Dissipation, internal	$P_D$		200	W
Input Voltage, differential	$V_{IN (Diff)}$	-20	20	V
Input Voltage, common mode	$V_{CM}$	$-V_S$	$V_S$	V
Temperature, pin solder, 10s			350	$^\circ\text{C}$
Temperature, junction <sup>1</sup>	$T_J$		150	$^\circ\text{C}$
Temperature, storage		-65	+150	$^\circ\text{C}$
Operating Temperature Range, case	$T_C$	-55	+125	$^\circ\text{C}$

1. Long term operation at the maximum junction temperature will result in reduced product life. Derate internal power dissipation to achieve high MTTF. For guidance, refer to the heatsink data sheet.

### CAUTION

The PA04 is constructed from MOSFET transistors. ESD handling procedures must be observed. The internal substrate contains beryllia (BeO). Do not break the seal. If accidentally broken, do not crush, machine, or subject to temperatures in excess of  $850^\circ\text{C}$  to avoid generating toxic fumes.

**INPUT**

Parameter	Test Conditions	PA04			PA04A			Units
		Min	Typ	Max	Min	Typ	Max	
Offset Voltage, initial			5	10		2	5	mV
Offset Voltage vs. temperature	Full temp range		30	50		10	30	$\mu\text{V}/^\circ\text{C}$
Offset Voltage vs. supply			15			*		$\mu\text{V}/\text{V}$
Offset Voltage vs. power	Full temp range		30			10		$\mu\text{V}/\text{W}$
Bias Current, initial			10	50		5	20	$\mu\text{A}$
Bias Current vs. supply			0.01			*		$\mu\text{A}/\text{V}$
Offset Current, initial			10	50		5	20	$\mu\text{A}$
Input Impedance, DC			$10^{11}$			*		$\Omega$
Input Capacitance			13			*		pF
Common Mode Voltage Range	Full temp range	$\pm V_B - 8$			*			V
Common Mode Rejection, DC	Full temp range, $V_{\text{CM}} = \pm 20\text{V}$	86	98		*	*		dB
Input Noise	100 kHz BW, $R_I = 1\text{ k}\Omega$		10			*		$\mu\text{V}_{\text{rms}}$

**GAIN**

Parameter	Test Conditions	PA04			PA04A			Units
		Min	Typ	Max	Min	Typ	Max	
Open Loop, @ 15 Hz	Full temp range, $C_C = 100\text{pF}$	94	102		*	*		dB
Gain Bandwidth Product	$I_{\text{OUT}} = 10\text{A}$		2			*		MHz
Power Bandwidth	$R_L = 4.5\ \Omega$ , $V_{\text{OUT}} = 180\text{V p-p}$ , $C_C = 100\text{pF}$ , $R_C = 120\ \Omega$		90			*		kHz
Phase Margin	Full temp range		60			*		$^\circ$

**OUTPUT**

Parameter	Test Conditions	PA04			PA04A			Units
		Min	Typ	Max	Min	Typ	Max	
Voltage Swing	$I_{OUT} = 15A$	$\pm V_S - 8.8$	$\pm V_S - 7.5$		*	*		V
Voltage Swing	$V_B = V_S + 5V, I_{OUT} = 20A$	$\pm V_S - 6.8$	$\pm V_S - 5.5$		*	*		V
Current, peak		20			*			A
Settling Time to 0.1%	$A_V = 1, 10V \text{ step}, R_L = 4 \Omega$		2.5			*		$\mu s$
Slew Rate	$A_V = 10, C_C = 100pF, R_C = 120 \Omega$	40	50		*	*		V/ $\mu s$
Capacitive Load	Full temp range, $A_V = +1$	10			*			nF
Resistance			2			*		$\Omega$

**POWER SUPPLY**

Parameter	Test Conditions	PA04			PA04A			Units
		Min	Typ	Max	Min	Typ	Max	
Voltage	Full temp range	$\pm 15$	$\pm 75$	$\pm 100$	*	*	*	V
Current, quiescent, boost supply			30	40		*	*	mA
Current, quiescent, total			70	90		*	*	mA
Current, quiescent, total, sleep mode	Full temp range		3	5		*	*	mA

**THERMAL**

Parameter	Test Conditions	PA04			PA04A			Units
		Min	Typ	Max	Min	Typ	Max	
Resistance, AC, junction to case <sup>1</sup>	Full temp range, $F > 60 \text{ Hz}$		0.3	0.4		*	*	$^{\circ}C/W$
Resistance, DC, junction to case	Full temp range, $F < 60 \text{ Hz}$		0.5	0.6		*	*	$^{\circ}C/W$
Resistance <sup>2</sup> , junction to air	Full temp range		12			*		$^{\circ}C/W$
Temperature Range, case	Meets full range specification	-25		85	*		*	$^{\circ}C$

1. Rating applies if the output current alternates between both output transistors at a rate faster than 60 Hz.
2. The PA04 must be used with a heatsink or the quiescent power may drive the unit to junction temperatures higher than 150°C.

**Note:** \*The specification of PA04A is identical to the specification for PA04 in applicable column to the left.

TYPICAL PERFORMANCE GRAPHS

Figure 4: Power Derating

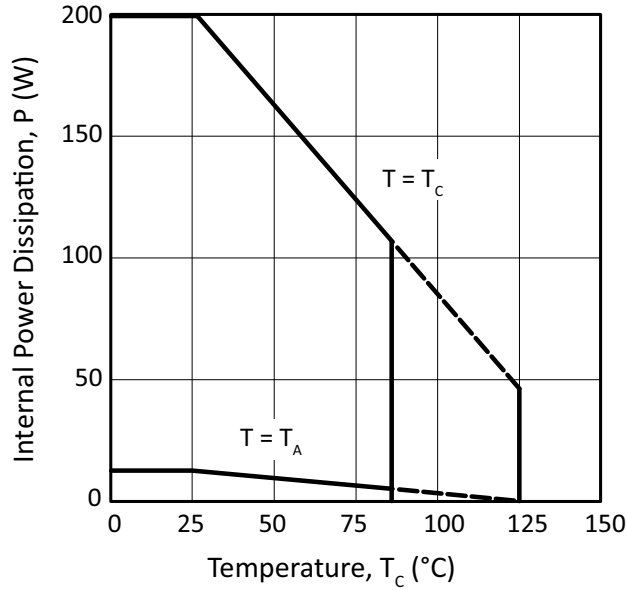

Figure 5: Power Supply Rejection

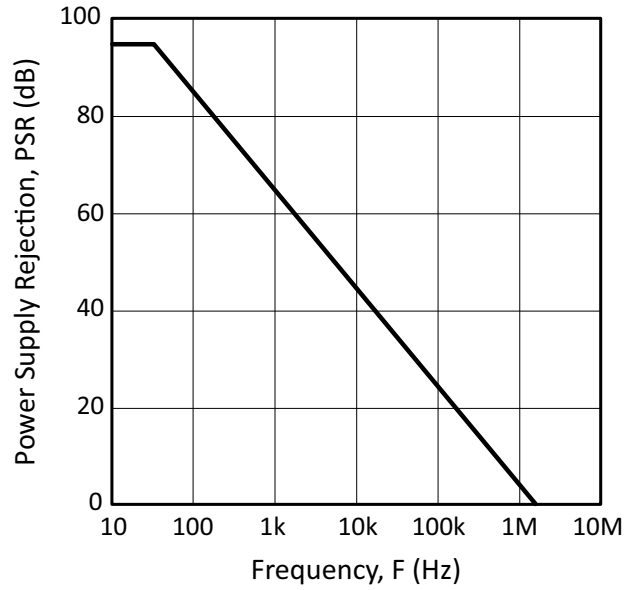

Figure 6: Small Signal Gain

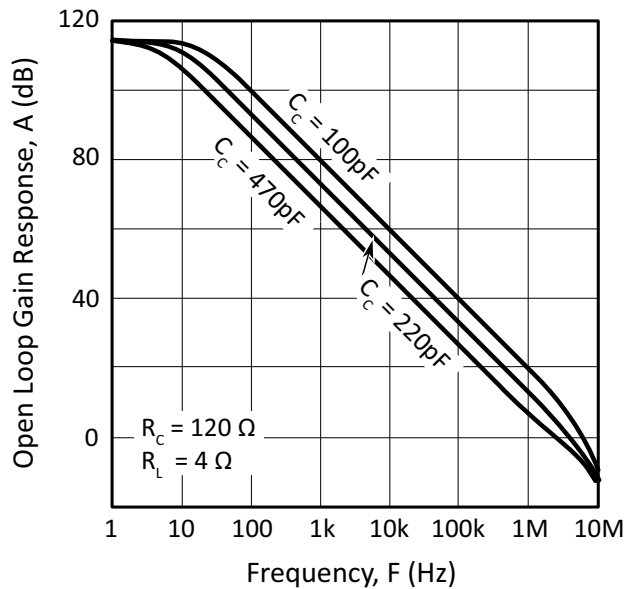

Figure 7: Small Signal Phase

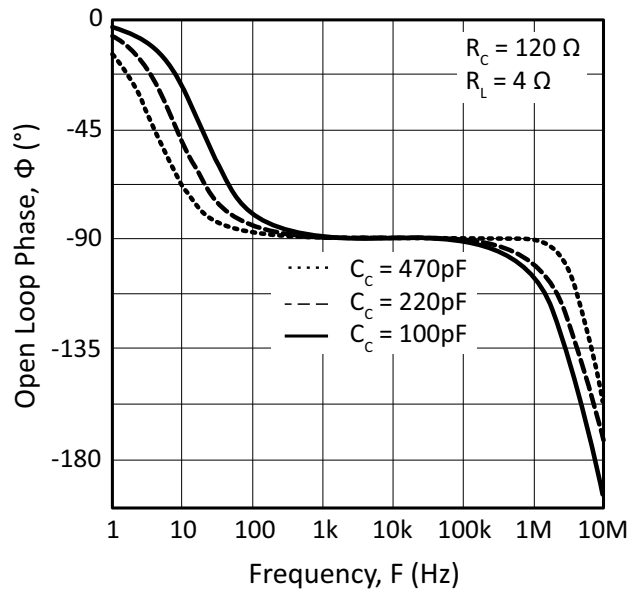

Figure 8: Slew Rate

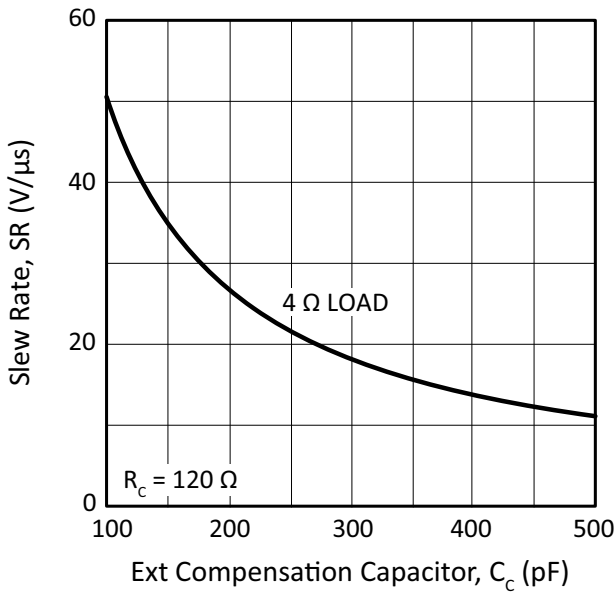

Figure 9: Output Voltage Swing

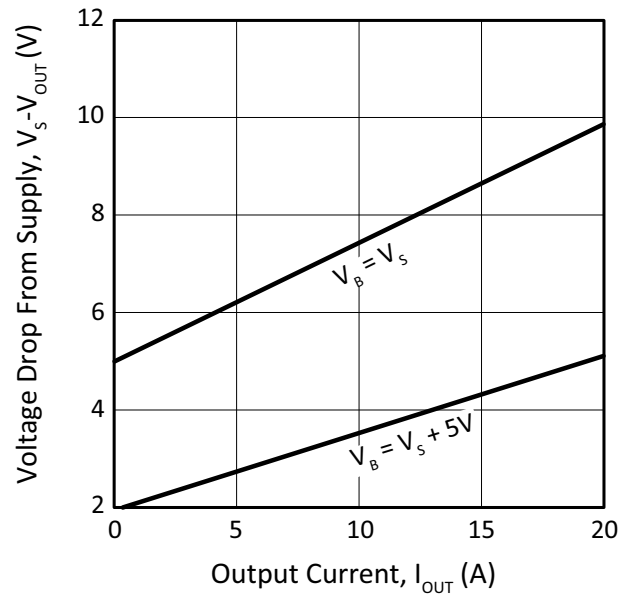

Figure 10: Common Mode Rejection

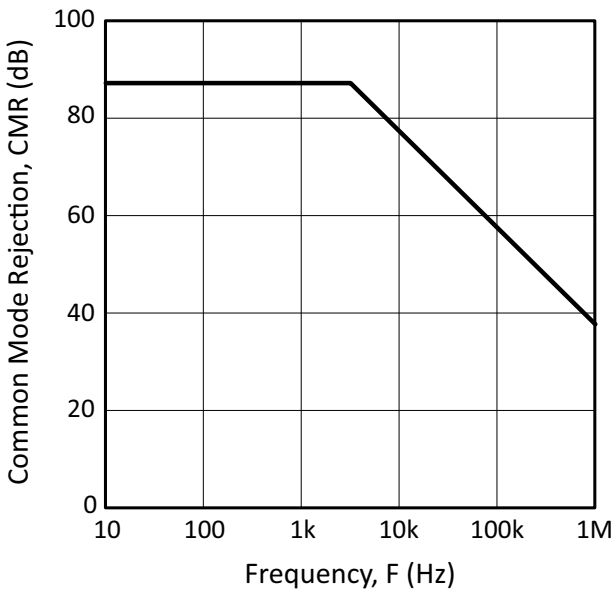

Figure 11: Pulse Response

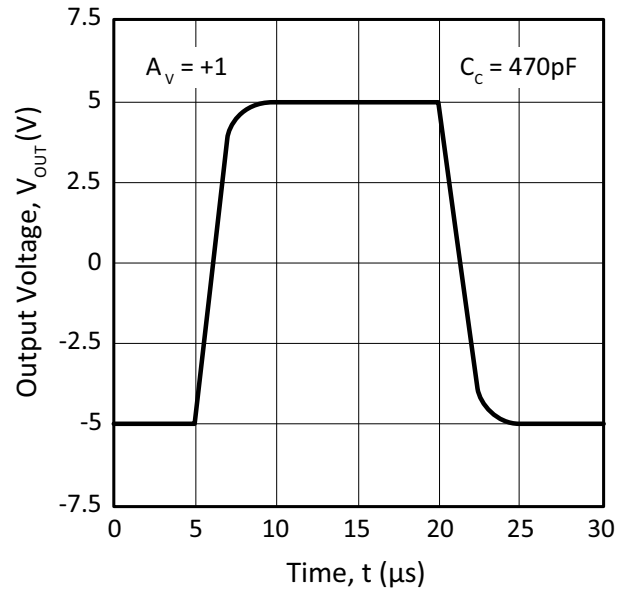

Figure 12: Current Limit

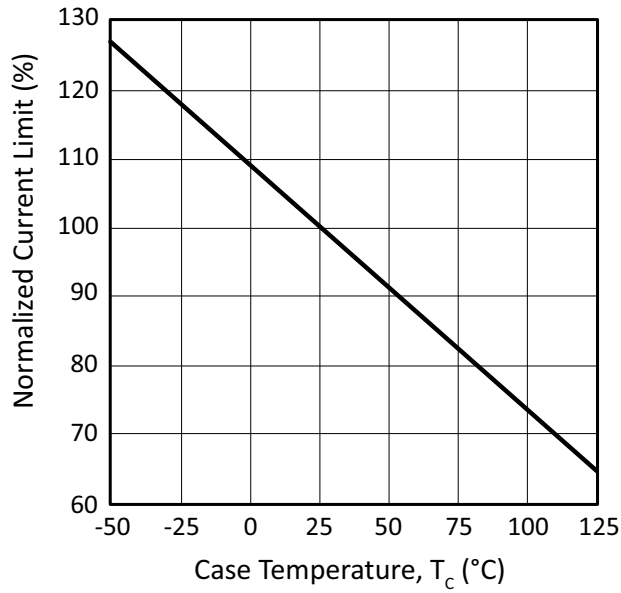

Figure 13: Harmonic Distortion

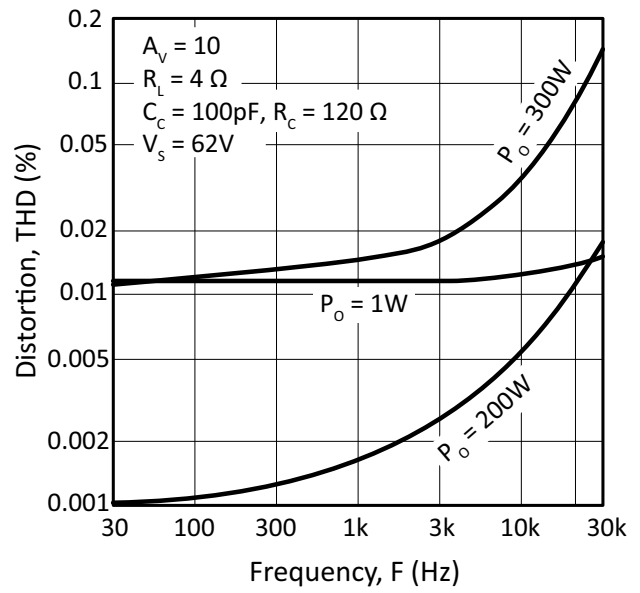

Figure 14: Quiescent Current

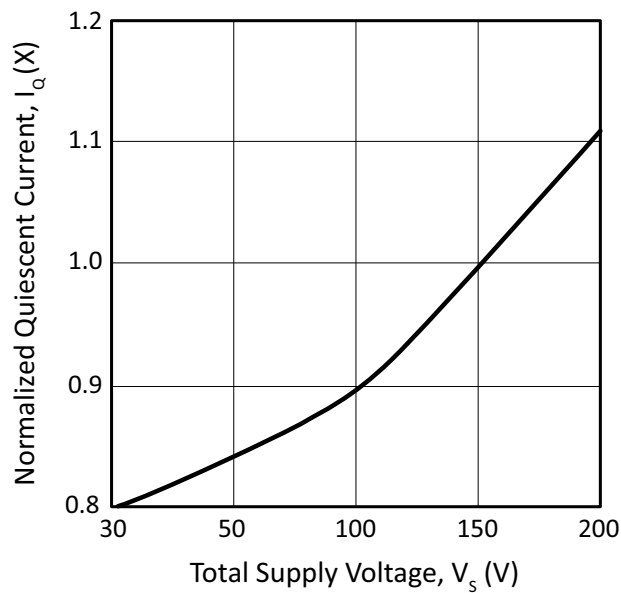
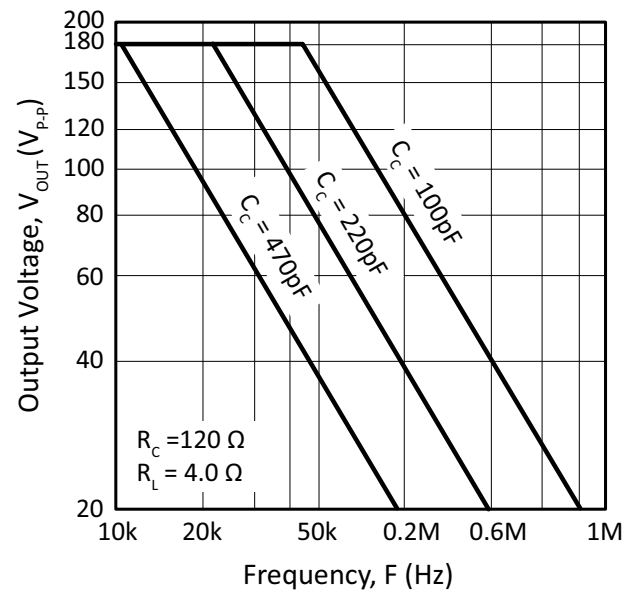

Figure 15: Power Response



**SAFE OPERATING AREA (SOA)**

The MOSFET output stage of this power operational amplifier has two distinct limitations:

1. The current handling capability of the MOSFET geometry and the wire bonds.
2. The junction temperature of the output MOSFETs.

**Note:** The output stage is protected against transient flyback. However, for protection against sustained, high energy flyback, external fast-recovery diodes should be used.

Figure 16: SOA

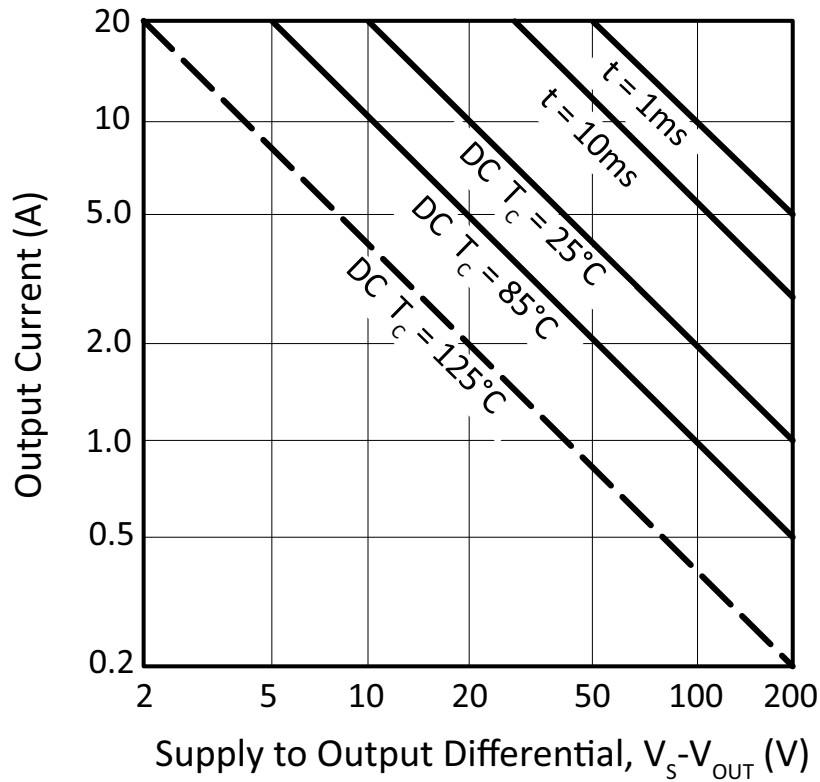

## GENERAL

Please read Application Note 1 “General Operating Considerations” which covers stability, supplies, heat sinking, mounting, current limit, SOA interpretation, and specification interpretation. Visit [www.apexanalog.com](http://www.apexanalog.com) for Apex Microtechnology’s complete Application Notes library, Technical Seminar Workbook, and Evaluation Kits.

## TYPICAL APPLICATION

**Figure 17: Typical Application (Sonar Transducer Driver)**

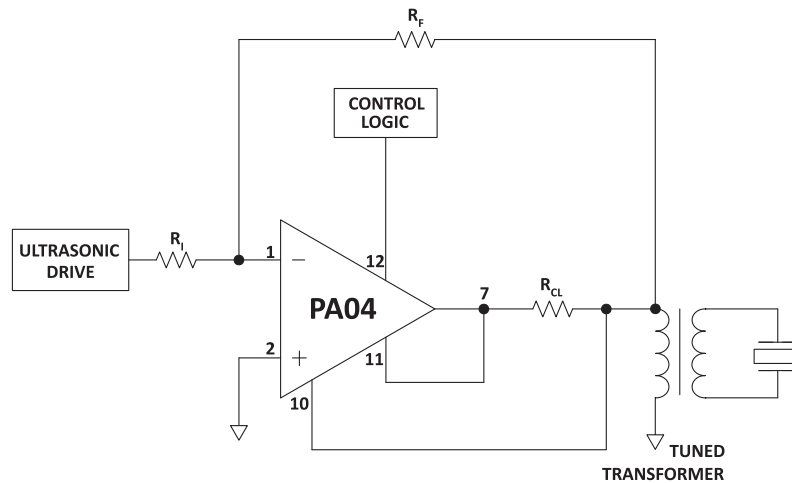

The high power bandwidth and high voltage output of the PA04 allows driving sonar transducers via a resonant circuit including the transducer and a matching transformer. The load circuit appears resistive to the PA04. Control logic turns off the amplifier in sleep mode.

## PHASE COMPENSATION

Gain	$C_C^*$	$R_C$
$\geq 1$	470pF	120 $\Omega$
$\geq 3$	220pF	120 $\Omega$
$\geq 10$	100pF	120 $\Omega$

$C_C$  Rated For Full Supply Voltage

\*See “BOOST OPERATION” paragraph.

**CURRENT LIMIT**

The two current limit sense lines are to be connected directly across the current limit sense resistor. For the current limit to work correctly pin 11 must be connected to the amplifier output side and pin 10 connected to the load side of the current limit resistor,  $R_{CL}$ , as shown in Figure 18. This connection will bypass any parasitic resistances,  $R_p$ , formed by sockets and solder joints as well as internal amplifier losses. The current limiting resistor may not be placed anywhere in the output circuit except where shown in Figure 18. The value of the current limit resistor can be calculated as follows:

$$R_{CL}(\Omega) = \frac{0.76V}{I_{CL}(A)}$$

**Figure 18: Current Limit**

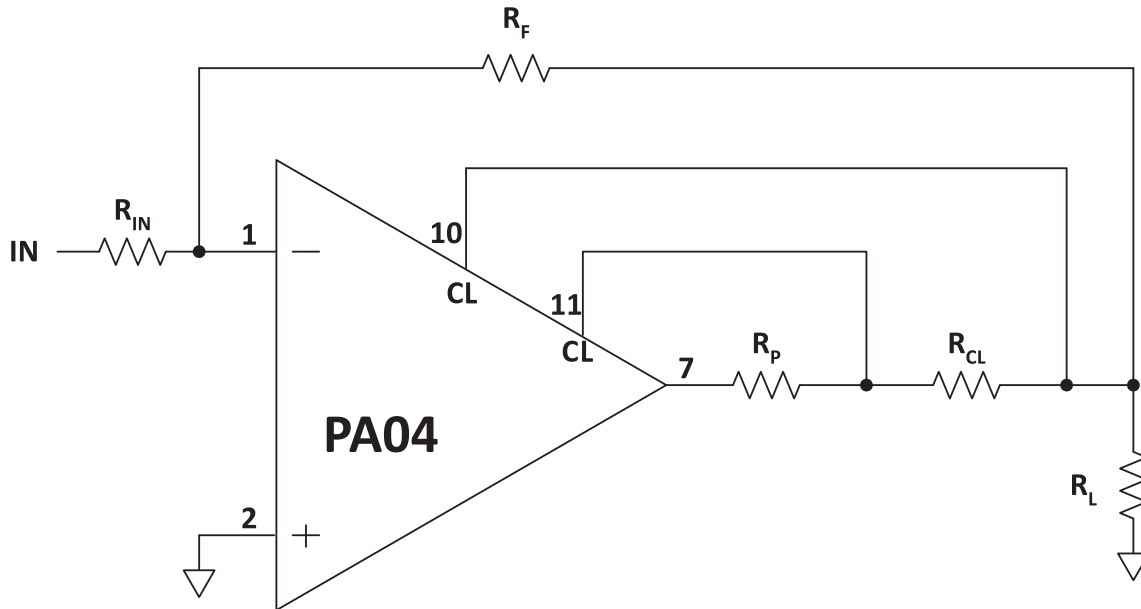

## SLEEP MODE OPERATION

To activate sleep mode, connect pin 12 (sleep) to pin 9 (+V<sub>B</sub>). This disables the amplifier's internal reference and the amplifier shuts down except for a trickle current of 3 mA which flows into pin 12. Pin 12 should be left open if the sleep mode is not required.

Several possible circuits can be built to take advantage of this mode. In Figure 19a a small signal relay is driven by a logic gate. This removes the requirement to deal with the common mode voltage that exists on the shutoff circuitry since the sleep mode is referenced to the +V<sub>B</sub> voltage.

In Figure 19b, circuitry is used to level translate the sleep mode input signal. The differential input activates sleep mode with a differential logic level signal and allows common mode voltages to ±V<sub>B</sub>.

Figure 19: Sleep Mode Current

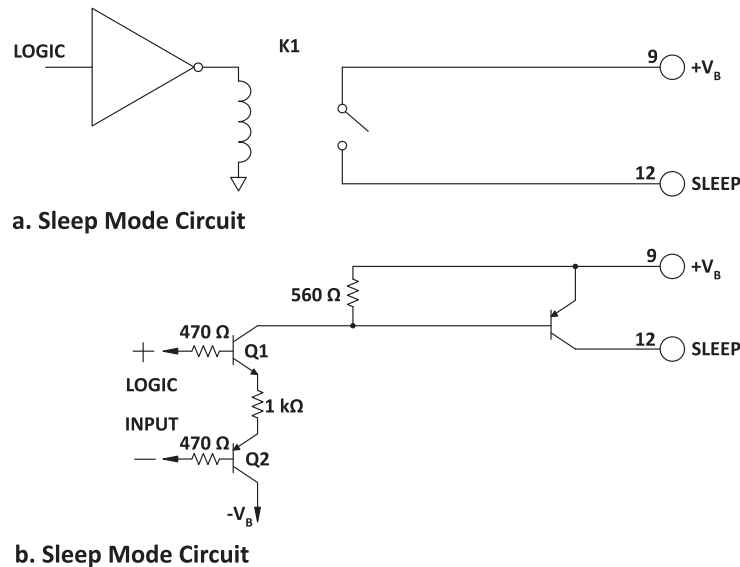

## BOOST OPERATION

With the V<sub>B</sub> feature the small signal stages of the amplifier are operated at higher supply voltages than the amplifier's high current output stage. +V<sub>B</sub> (pin 9) and -V<sub>B</sub> (pin 5) are connected to the small signal circuitry of the amplifier. +V<sub>S</sub> (pin 8) and -V<sub>S</sub> (pin 6) are connected to the high current output stage. An additional 5V on the V<sub>B</sub> pins is sufficient to allow the small signal stages to drive the output transistors into saturation and improve the output voltage swing for extra efficient operation when required. When close swings to the supply rails is not required the +V<sub>B</sub> and +V<sub>S</sub> pins must be strapped together as well as the -V<sub>B</sub> and -V<sub>S</sub> pins. The V<sub>B</sub> pins must not be at a voltage lower than the V<sub>S</sub> pins.

## COMPENSATION

The external compensation components C<sub>C</sub> and R<sub>C</sub> are connected to pins 3 and 4. Unity gain stability can be achieved at any compensation capacitance greater than 330 pF with at least 60 degrees of phase margin. At higher gains more phase shift can be tolerated in most designs and the compensation capacitance can accordingly be reduced, resulting in higher bandwidth and slew rate. Use the typical operating curves as a guide to select C<sub>C</sub> and R<sub>C</sub> for the application.

**PACKAGE DESIGN**

**PACKAGE STYLE CR**

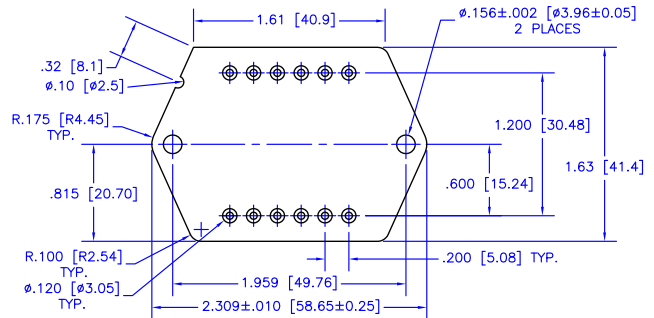
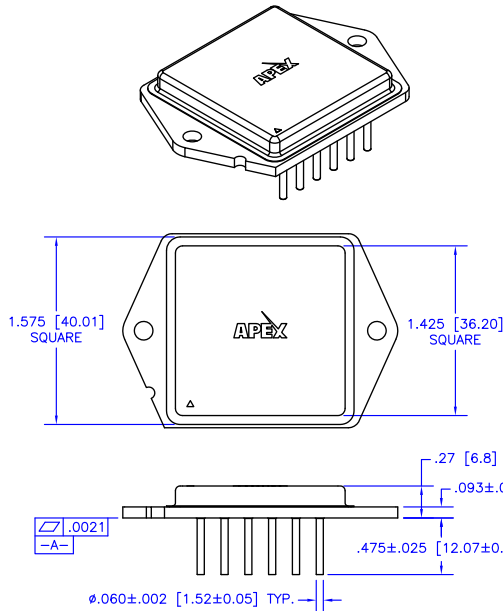

**NOTES:**

1. Dimensions are in inches & [mm].
2. Triangle on lid and notch in header denote pin 1.
3. Header material: Nickel-plated CRS
4. Lid material: Solid nickel
5. Pin material: Solderable nickel-plated Alloy 52
6. Welded hermetic package seal
7. Isolation: 1000 VDC any pin to case
8. Package weight: 1.87 oz [53 g]

**NEED TECHNICAL HELP? CONTACT APEX SUPPORT!**

For all Apex Microtechnology product questions and inquiries, call toll free 800-546-2739 in North America. For inquiries via email, please contact [apex.support@apexanalog.com](mailto:apex.support@apexanalog.com). International customers can also request support by contacting their local Apex Microtechnology Sales Representative. To find the one nearest to you, go to [www.apexanalog.com](http://www.apexanalog.com)

**IMPORTANT NOTICE**

Apex Microtechnology, Inc. has made every effort to insure the accuracy of the content contained in this document. However, the information is subject to change without notice and is provided "AS IS" without warranty of any kind (expressed or implied). Apex Microtechnology reserves the right to make changes without further notice to any specifications or products mentioned herein to improve reliability. This document is the property of Apex Microtechnology and by furnishing this information, Apex Microtechnology grants no license, expressed or implied under any patents, mask work rights, copyrights, trademarks, trade secrets or other intellectual property rights. Apex Microtechnology owns the copyrights associated with the information contained herein and gives consent for copies to be made of the information only for use within your organization with respect to Apex Microtechnology integrated circuits or other products of Apex Microtechnology. This consent does not extend to other copying such as copying for general distribution, advertising or promotional purposes, or for creating any work for resale.

APEX MICROTECHNOLOGY PRODUCTS ARE NOT DESIGNED, AUTHORIZED OR WARRANTED TO BE SUITABLE FOR USE IN PRODUCTS USED FOR LIFE SUPPORT, AUTOMOTIVE SAFETY, SECURITY DEVICES, OR OTHER CRITICAL APPLICATIONS. PRODUCTS IN SUCH APPLICATIONS ARE UNDERSTOOD TO BE FULLY AT THE CUSTOMER OR THE CUSTOMER'S RISK.

Apex Microtechnology, Apex and Apex Precision Power are trademarks of Apex Microtechnology, Inc. All other corporate names noted herein may be trademarks of their respective holders.

# Mouser Electronics

Authorized Distributor



Click to View Pricing, Inventory, Delivery & Lifecycle Information:

[Apex Microtechnology:](#)

[PA04](#) [PA04A](#)

## Looking for pricing, stock, or lifecycle information?

Click below to explore more details on WIN SOURCE:

-  [View PA04A on WIN SOURCE](#)
-  [Apex Microtechnology Information](#)

## Optimize Your Supply Chain with WIN SOURCE Solutions

-  Global Sourcing Solution
-  Obsolete Management
-  Cost Control Management
-  Shortage Management
-  Alternative Solution
-  Excess Inventory Management