

Features

- 3 Terminal LPF Broadband Shunt Structure
- 50 MHz - 12 GHz Broadband Frequency
- >100 W Peak Power Handling
- < 0.1 dB Shunt Insertion Loss
- > 25 dB Shunt Isolation
- < 20°C/W Thermal Resistance
- Lead-Free 1.5 x 1.2 mm 6-lead TDFN Package
- RoHS* Compliant and 260°C Reflow Compatible

Description

The MADP-011029 is a lead-free 1.5 x 1.2 mm TDFN surface mount plastic package that provides both low and high signal frequency operation from 50 MHz to 12 GHz. The higher breakdown voltage and lower thermal resistance of the PIN diode provides peak power handling in excess of 100 W.

This device is ideally suitable for usage in higher incident power switches, phase shifters, attenuators, and limiter microwave circuits over a broad frequency where higher performance surface mount diode assemblies are required.

Ordering Information^{1,2}

| Part Number | Package |
|--------------------|-----------------|
| MADP-011029-14150T | 3000 piece reel |
| MADP-011029-000SMB | Sample board |

1. Reference Application Note [M513](#) for reel size information.
2. All RF Sample boards include 5 loose parts.

Functional Schematic

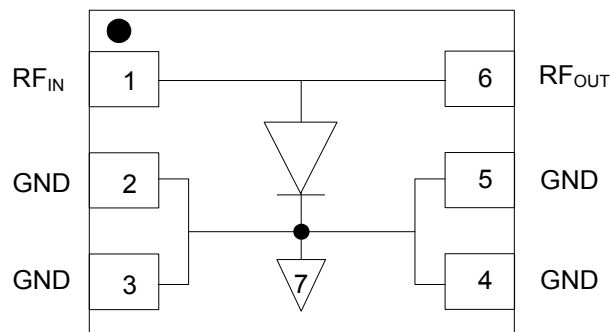

Pin Configuration³

| Pin No. | Pin Name | Description |
|---------|---------------------|-------------|
| 1 | RF _{IN} | RF Input |
| 2 | GND | Ground |
| 3 | GND | Ground |
| 4 | GND | Ground |
| 5 | GND | Ground |
| 6 | RF _{OUT} | RF Output |
| 7 | Paddle ⁴ | Ground |

3. MACOM recommends connecting unused package pins to ground.
4. The exposed pad centered on the package bottom must be connected to RF, DC, and thermal ground.

* Restrictions on Hazardous Substances, European Union Directive 2011/65/EU.

High Power PIN Diode
50 MHz - 12 GHz

Rev. V3

Electrical Specifications: T_A = +25°C

| Parameter | Test Conditions | Units | Min. | Typ. | Max. |
|--|--|-------|------|------|-------|
| Forward Voltage | + 50 mA DC | V | 0.7 | 0.9 | 1.1 |
| Reverse Leakage Current | -200 V DC | nA | — | - 20 | -1000 |
| Total Capacitance ⁵ | -50 V @ 1 GHz | pF | — | 0.31 | 0.40 |
| Series Resistance ⁶ | +10 mA @ 1 GHz | Ω | — | 1.5 | 1.9 |
| Parallel Resistance ⁶ | -Vdc = -40 V, @ 100 MHz | KΩ | — | 1000 | — |
| Minority Carrier Lifetime | +If = 10 mA / -I _r = -6 mA (50% Control Voltage, 90% Output Voltage) | μs | — | 1.0 | 2.0 |
| CW Thermal Resistance (Infinite Heat Sink at Thermal Ground Plane) | I High = 4 A, I low = 10 mA @ 10 kHz | °C/W | — | 20 | — |
| Power Dissipation ^{7,8} (Infinite Heat Sink at Thermal Ground Plane) | +If = 50 mA @ 1 GHz | W | — | 7.5 | — |
| Insertion Loss | F = 1 GHz, -Vdc = -10 V | dB | — | 0.1 | — |
| Isolation | F = 1 GHz, +I bias = +10 mA | dB | 23 | 25 | — |

5. C_t (Total Capacitance) = C_J (Junction Capacitance) + C_p (Parasitic Package Capacitance).

6. R_s and R_p are measured on an HP4291A Impedance Analyzer.

7. De-rate power dissipation linearly by -50 mW/°C to 0 W @ +175°C: P_d (T) = P_d (+25°C) - ΔP = P_d (+25°C) - (50 mW/°C) (ΔT).

8. PD = ΔT_j / Θ or PD=(IF + IRF)² (R_s), where IF is the forward bias DC current and IRF is the forward bias RMS RF current.

Absolute Maximum Ratings^{9,10}

| Parameter | Absolute Maximum |
|---------------------------------|------------------|
| DC Forward Voltage @ +250 mA | 1.2 V |
| DC Forward Current | 250 mA |
| DC Reverse Voltage | -400 V |
| Junction Temperature | +175°C |
| Operating Temperature | -65°C to +125°C |
| Storage Temperature | -65°C to +150°C |

9. Exceeding any one or combination of these limits may cause permanent damage to this device.

10. MACOM does not recommend sustained operation near these survivability limits.

Handling Procedures

Please observe the following precautions to avoid damage:

Static Sensitivity

These devices are sensitive to electrostatic discharge (ESD) and can be damaged by static electricity. Proper ESD control techniques should be used when handling these Class 1B devices.

PCB Layout

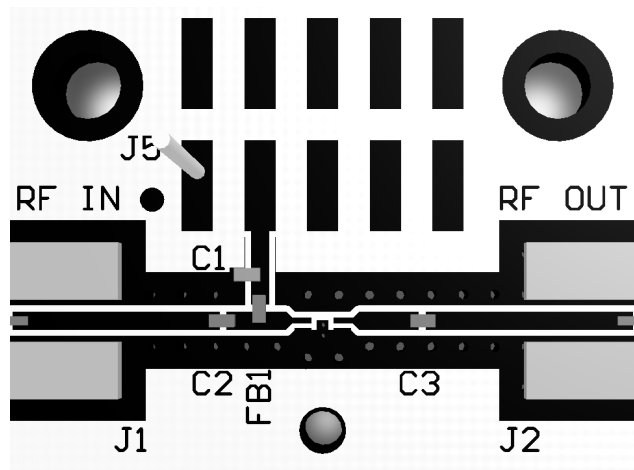

PCB Schematic

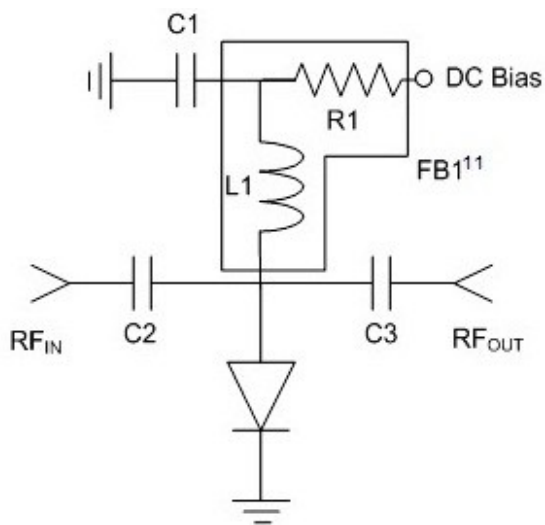

11. R1 is not needed when using the recommended ferrite FB1.

500 - 5000 MHz Parts List¹²

| Part | Value | Case Style |
|--------|----------------------|------------|
| C1 | 62 pF | 0402 |
| C2, C3 | 100 pF | 0402 |
| FB1 | 470 Ω @ 1 GHz | 0402 |
| R1 | 150 Ω | 0402 |
| L1 | 82 nH | 0402 |

12. Max DC voltage with recommended components not to exceed 100 V.

Assembly Recommendations

Devices may be soldered using standard Pb60/Sn40, or RoHS compliant solders. Leads are plated NiPdAuAg to ensure an optimum solderable connection.

For recommended Sn/Pb and RoHS soldering profile See Application Note [M538](#) on the MACOM website.

Cleanliness and Storage

These devices should be handled and stored in a clean environment. Ends of the device are NiPdAuAg plated for greater solderability. Exposure to high humidity (>80%) for extended periods may cause the surface to oxidize. Caution should be taken when storing devices for long periods.

General Handling

Device can be handled with tweezers or vacuum pickups and are suitable for use with automatic pick-and-place equipment.

Typical 1 GHz Parametric Curves

Series Resistance vs. Forward Current

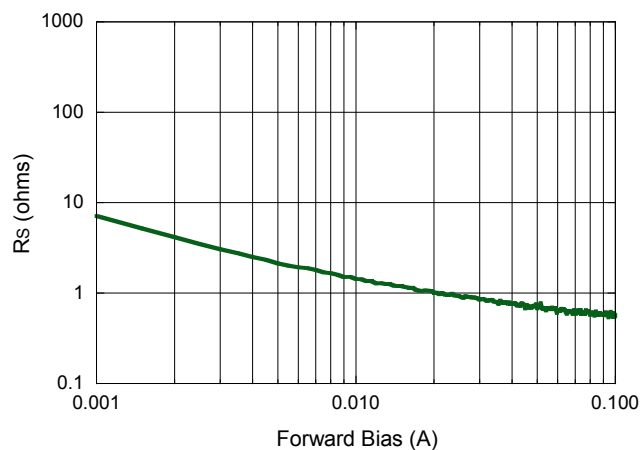

Capacitance vs. Reverse Voltage

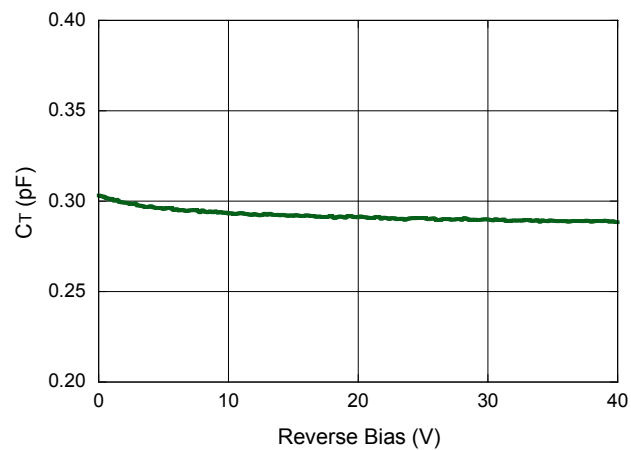

Parallel Resistance vs. Reverse Voltage

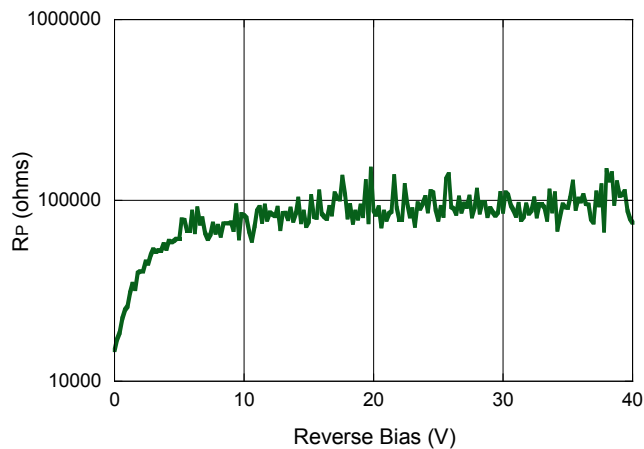

Typical RF Small Signal Performance Curves

Insertion Loss

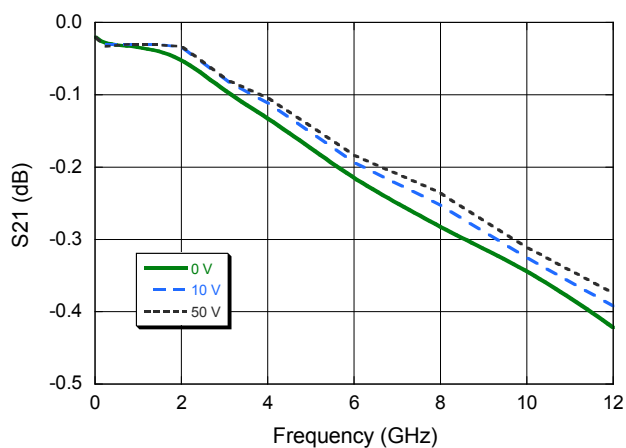

Return Loss

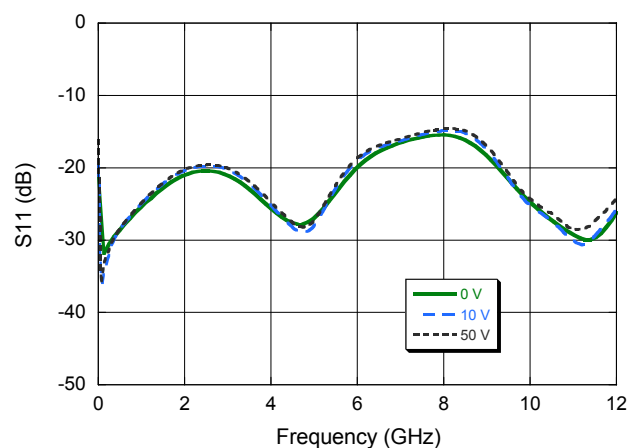

Isolation

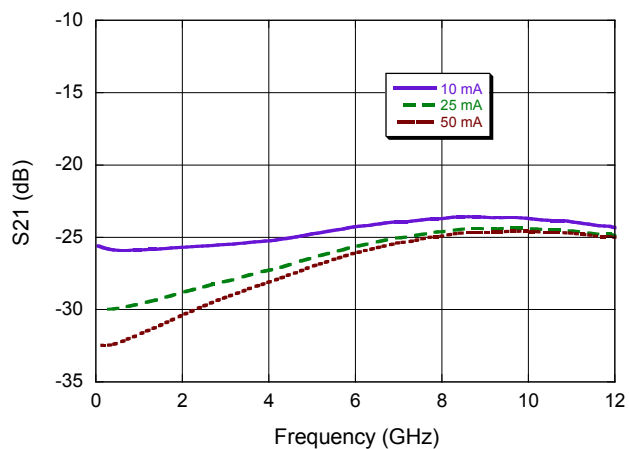

Lead-Free 1.5 x 1.2 mm 6-Lead TDFN[†]

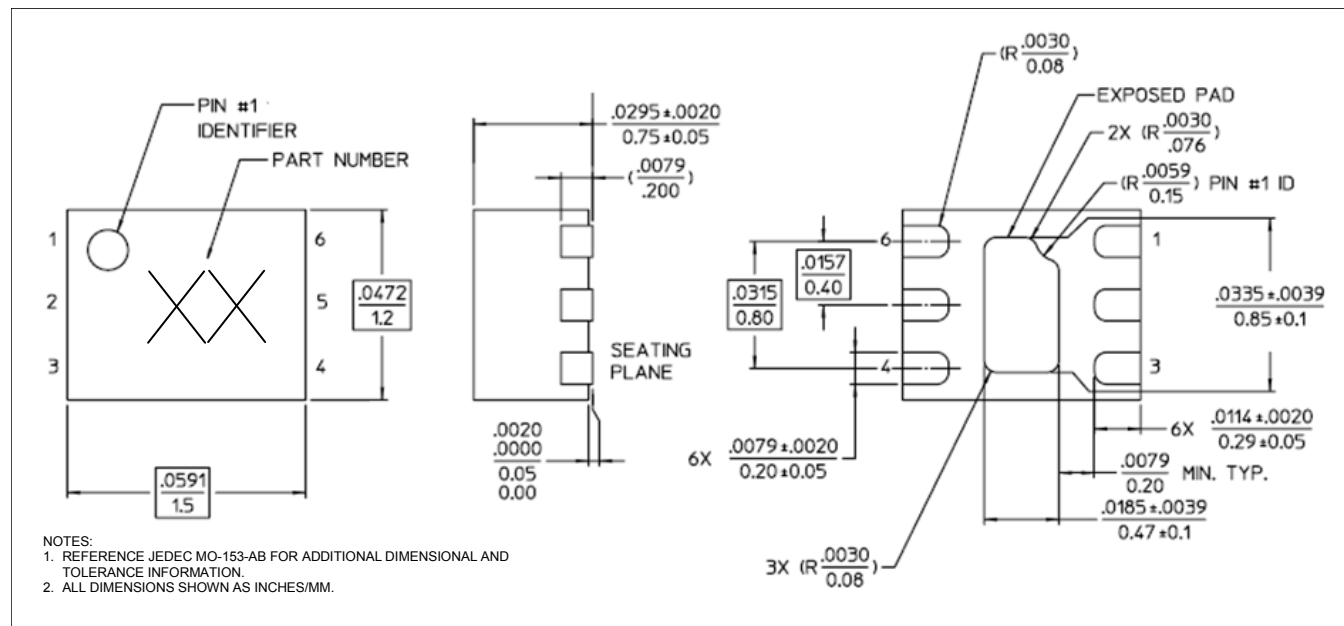

[†] Reference Application Note [S2083](#) for lead-free solder reflow recommendations.
 Meets JEDEC moisture sensitivity level 1 requirements.
 Plating is NiPdAuAg.

Applications Section

Schematic of High Power SP2T Shunt Switch using MADP-011029-14150T PIN Diodes
F = Octave Bandwidth from 1 to 12 GHz
 $P_{inc} = +40$ dBm CW
 $P_{inc} = +50$ dBm, 10 μ s PW, 1% Duty

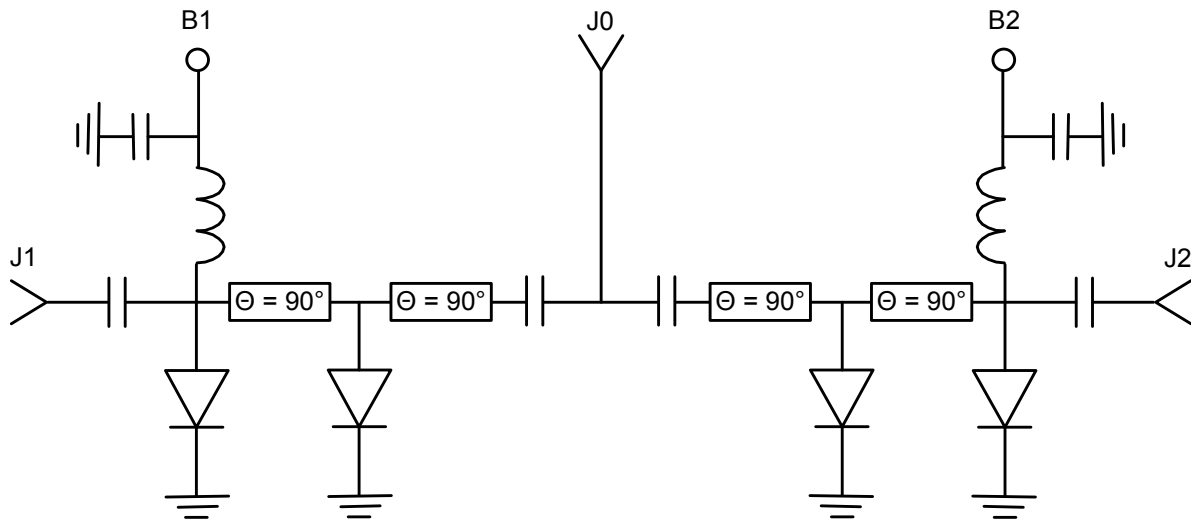

$$L = 11.807 / (\epsilon_{eff}^{1/2} * F * 4) \text{ inches, } \theta = \beta * L = (2 \pi / \lambda) * L = 90^\circ$$

Frequency is in GHz, ϵ_{eff} is Effective Dielectric Constant of Transmission Line Medium

| RF State | B1 Bias | B2 Bias |
|----------------------------------|---------------|---------------|
| J0-J1 Low Loss & J0-J2 Isolation | -50 V @ 0 mA | +1 V @ +20 mA |
| J0-J2 Low Loss & J0-J1 Isolation | +1 V @ +20 mA | -50 V @ 0 mA |

Applications Section

Schematic of 3 Stage Limiter using MADP-011029-14150T
 $F = 1000 - 8000 \text{ MHz}$
 $P_{inc} = +47 \text{ dBm CW}$
 $P_{inc} = +50 \text{ dBm, } 10 \mu\text{s P.W., } 1\% \text{ Duty}$

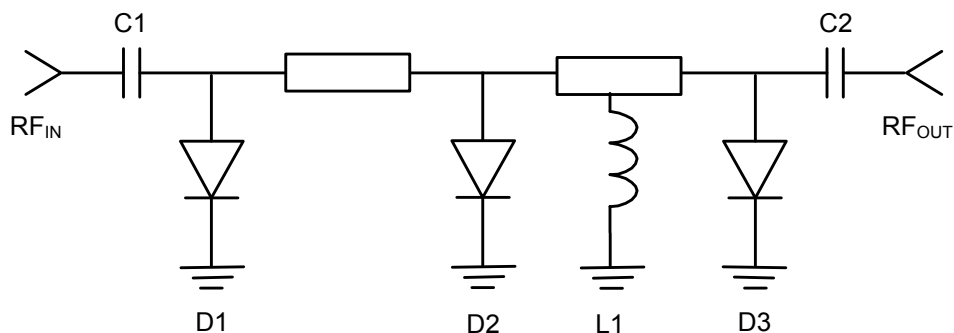

| Part | PN | Case Style | Description | Quantity |
|------|--------------------|------------|----------------------|----------|
| D1 | MADP-011029-14150T | ODS-1415 | Input PIN Diode | 1 |
| D2 | MADL-011023-14150T | ODS-1415 | 2nd Stage PIN Diode | 1 |
| D3 | MADL-011023-14150T | ODS-1415 | 3rd Stage PIN Diode | 1 |
| L1 | 33 nH | 0402 | RF Choke / DC Return | 1 |
| C1 | 27 pF | 0402 | DC Block | 1 |
| C2 | 27 pF | 0402 | DC Block | 1 |

Microwave Model of MADP-011029-14150T

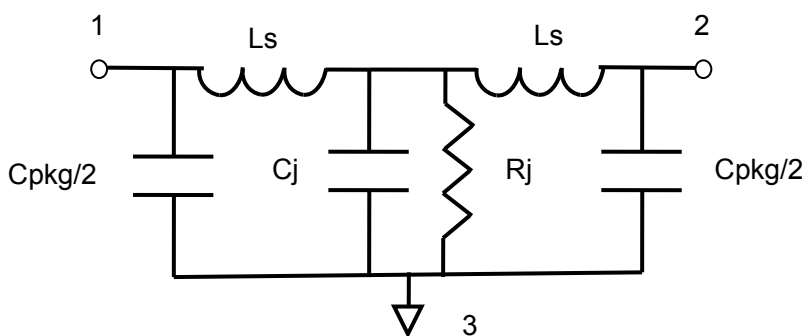
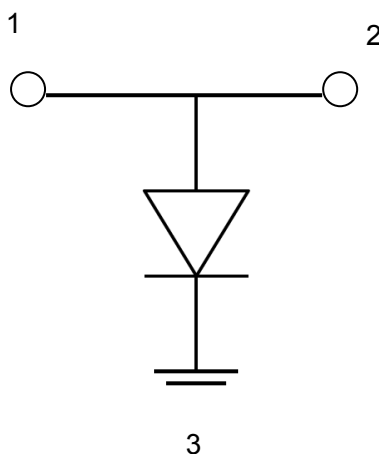

$R_j = R_s$ (Forward Bias Current)
 $R_j = R_p$ (Reverse Bias Voltage)

| Parameter | Value |
|----------------------|---------------|
| C_{package} | 8.0E-14 F |
| L bond = L_s | 4.0E-10 H |
| R_s | 0.9 Ω |
| R_p | 5E+5 Ω |

Looking for pricing, stock, or lifecycle information?

Click below to explore more details on WIN SOURCE:

 [View MADP-011029-14150T on WIN SOURCE](#)

 [Macroblock Information](#)

Optimize Your Supply Chain with WIN SOURCE Solutions

-  Global Sourcing Solution
-  Obsolete Management
-  Cost Control Management
-  Shortage Management
-  Alternative Solution
-  Excess Inventory Management