



THE DATASHEET OF HMC658



WIDEBAND FIXED ATTENUATOR FAMILY, DC - 50 GHz HMC650 / 651 / 652 / 653 / 654 / 655 / 656 / 657 / 658

Typical Applications

The HMC650 through HMC658 are ideal for:

- Fiber Optics
- Microwave Radio
- Military & Space Hybrids
- Test & Measurement
- Scientific Instruments
- RF / Microwave Circuit Prototyping

Features

Wide Bandwidth: DC - 50 GHz

9 Attenuator Products:

0, 2, 3, 4, 6, 10, 15, & 20 dB Fixed Levels

Power Handling: +25 dBm

HMC651 & HMC658

Die Size: 0.57 x 0.45 x 0.1 mm

HMC650, HMC652, HMC653, HMC654

HMC655, HMC656 & HMC657

Die Size: 0.42 x 0.45 x 0.1 mm

Included in the HMC-DK006 Designer's Kit

Functional Diagrams

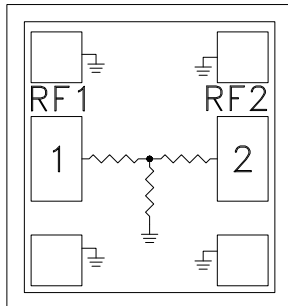

HMC650, HMC652, HMC653, HMC654,
HMC655, HMC656 & HMC657

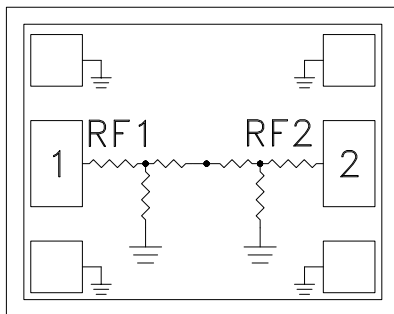

HMC651, HMC658

General Description

The HMC650 / 651 / 652 / 653 / 654 / 655 / 656 / 657 / 658 are a line of wideband fixed value 50 Ohm matched attenuator chips which offer relative attenuation levels of 0, 2, 3, 4, 6, 10, 15 and 20 dB. These passive through-lines and attenuators are ideal for microstrip, hybrid, and multi-chip module applications where extremely flat attenuation, and excellent VSWR vs. frequency are required.

These wideband attenuators feature low inductance on-chip vias, and require no additional ground connections. The HMC650 through HMC658 are backside metallized with gold, and are suitable for eutectic or epoxy die attach. Each of the 9 products can be purchased individually by their respective part number or in a set of 10 each in the HMC-DK006 Fixed Attenuator Chip Designer's Kit.

WIDEBAND FIXED ATTENUATOR FAMILY, DC - 50 GHz HMC650 / 651 / 652 / 653 / 654 / 655 / 656 / 657 / 658

Electrical Specifications, $T_A = +25^\circ\text{C}$, 50 Ohm system ^[1]

Part Number	Attenuator Value	Return Loss	Attenuation Tolerance	Return Loss	Attenuation Tolerance	Units
		DC - 25		25 - 50		
HMC650	Thru Line (short)	20.3	±0.2	12.4	±0.8	dB
HMC651	Thru Line (long)	19.0	±0.3	12.3	±0.9	dB
HMC652	2 dB	22.0	±0.2	15.3	±0.6	dB
HMC653	3 dB	23.0	±0.2	22.1	±0.5	dB
HMC654	4 dB	20.5	±0.2	22.4	±0.5	dB
HMC655	6 dB	16.5	±0.2	17.0	±0.6	dB
HMC656	10 dB	16.9	±0.1	18.8	±0.7	dB
HMC657	15 dB	20.0	±0.4	19.7	±1.3	dB
HMC658	20 dB	17.5	±0.5	16.2	±1.6	dB

RF Data with Wire Bonds ^[1]

Attenuation vs. Temperature
HMC652, HMC653, HMC654, HMC655

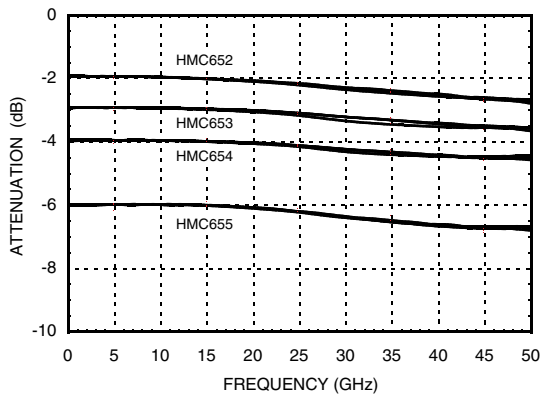

Attenuation vs. Temperature
HMC656, HMC657, HMC658

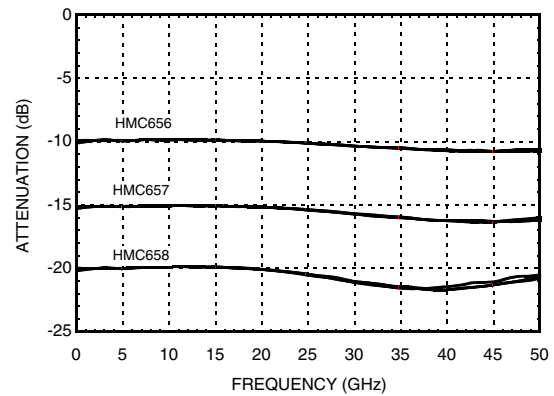

Return Loss
HMC652, HMC653, HMC654, HMC655

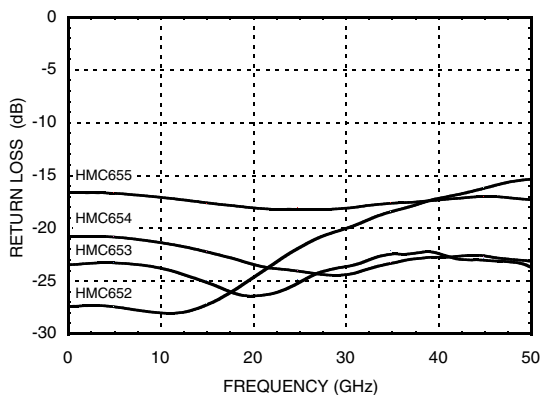

Return Loss
HMC656, HMC657, HMC658

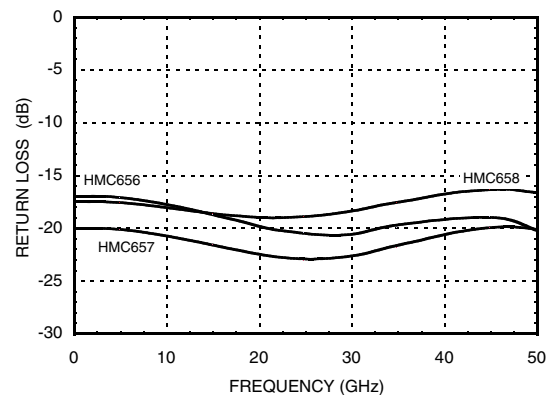

[1] Data taken with die mounted to plate and RF probed through two 1 mil diameter wire bonds.

v02.0218

**WIDEBAND FIXED ATTENUATOR FAMILY, DC - 50 GHz
HMC650 / 651 / 652 / 653 / 654 / 655 / 656 / 657 / 658**

RF Data with Ribbon Bonds [2]

**Attenuation vs. Temperature
HMC652, HMC653, HMC654, HMC655**

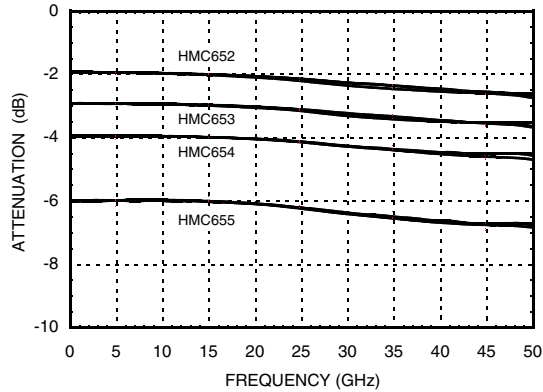

**Attenuation vs. Temperature
HMC656, HMC657, HMC658**

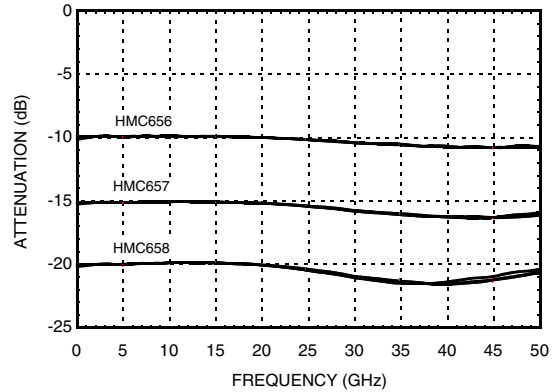

**Return Loss
HMC652, HMC653, HMC654, HMC655**

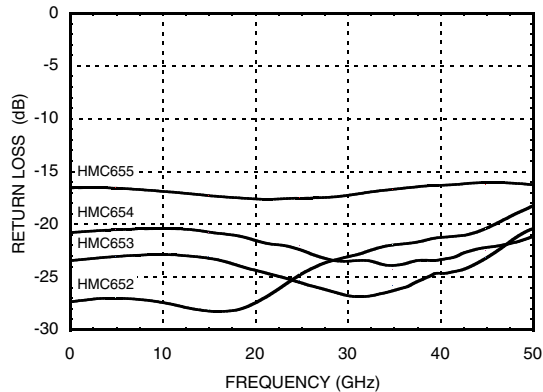

**Return Loss
HMC656, HMC657, HMC658**

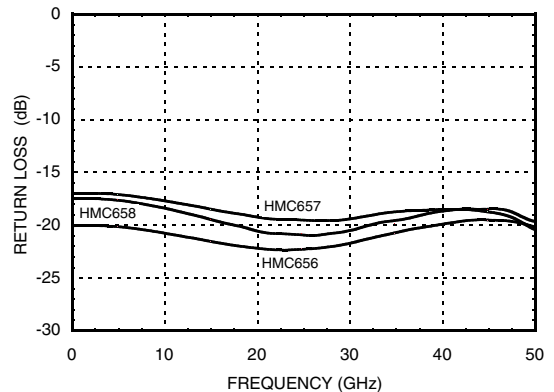

[2] Data taken with die mounted to plate and RF probed through two 3 x 0.5 mil ribbon bonds.

WIDEBAND FIXED ATTENUATOR FAMILY, DC - 50 GHz HMC650 / 651 / 652 / 653 / 654 / 655 / 656 / 657 / 658

RF Data Die Only [3]

Attenuation vs. Temperature
HMC652, HMC653, HMC654, HMC655

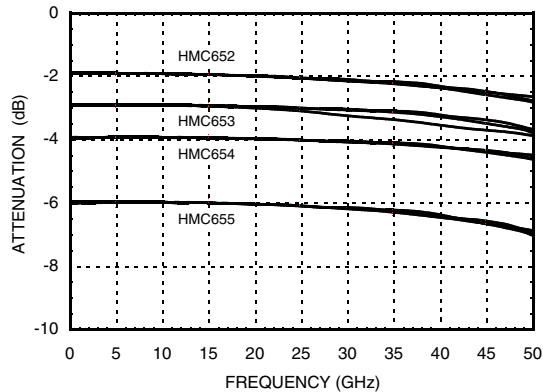

Attenuation vs. Temperature
HMC656, HMC657, HMC658

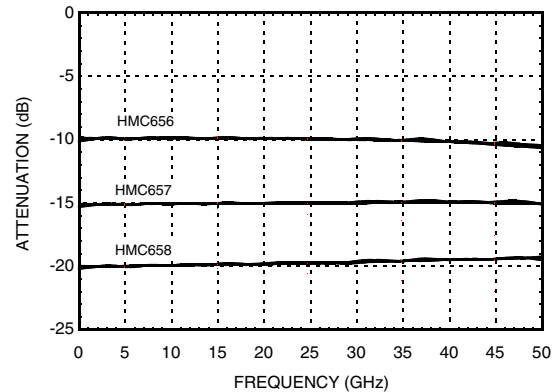

Return Loss
HMC652, HMC653, HMC654, HMC655

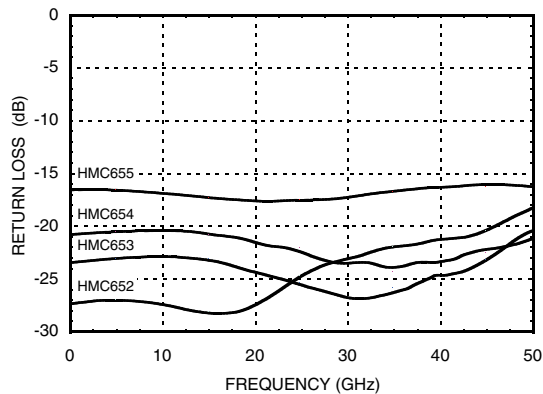

Return Loss
HMC656, HMC657, HMC658

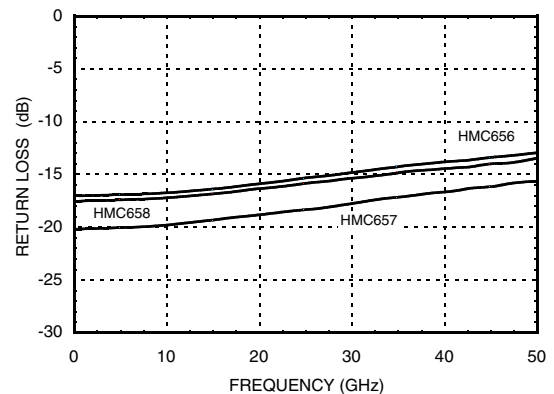

Absolute Maximum Ratings

Part Number	HMC650	HMC651	HMC652	HMC653	HMC654	HMC655	HMC656	HMC657	HMC658	Units
RF Input Power (CW)	N/A	N/A	27	26	25	26	25	25	25	dBm
DC Voltage Terminated	N/A	N/A	5.6	5.2	4.9	5.2	4.9	4.4	4.8	V
DC Voltage Open	N/A	N/A	5.6	5.1	4.6	6.0	5.3	4.6	4.9	V
Storage Temperature	-65 to +150									°C
Operating Temperature	-55 to +85									°C



ELECTROSTATIC SENSITIVE DEVICE
OBSERVE HANDLING PRECAUTIONS

[3] Data taken with die mounted to a plate and RF probed directly on die.

v02.0218

WIDEBAND FIXED ATTENUATOR FAMILY, DC - 50 GHz
HMC650 / 651 / 652 / 653 / 654 / 655 / 656 / 657 / 658

Outline Drawing

HMC650, HMC652, HMC653, HMC654, HMC655, HMC656 HMC657

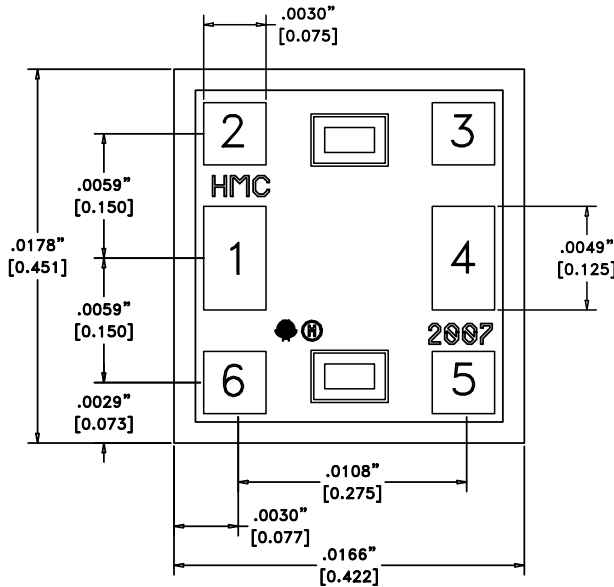

PAD	DESCRIPTION	PAD SIZE
1	RF1	.0030[.075] X .0049[.125]
2, 3	GND	.0030[.075] X .0030[.075]
4	RF2	.0030[.075] X .0049[.125]
5, 6	GND	.0030[.075] X .0030[.075]

NOTES:

1. ALL DIMENSIONS ARE IN INCHES (MILLIMETERS).
2. TYPICAL BOND PAD SPACING IS .006" CENTER TO CENTER EXCEPT AS NOTED.
3. BACKSIDE METALIZATION: GOLD
4. BACKSIDE METAL IS GROUND
5. BOND PAD METALIZATION: GOLD
6. DO NOT BOND ON TOP OF GROUND VIAS
7. OVERALL DIE SIZE ± 0.002 "

Die Packaging Information ^[1]

Standard	Alternate
GP-5 (Gel Pack)	[2]

[1] Refer to the "Packaging Information" section for die packaging dimensions.

[2] For alternate packaging information contact Analog Devices Inc..

Outline Drawing

HMC651 & HMC658

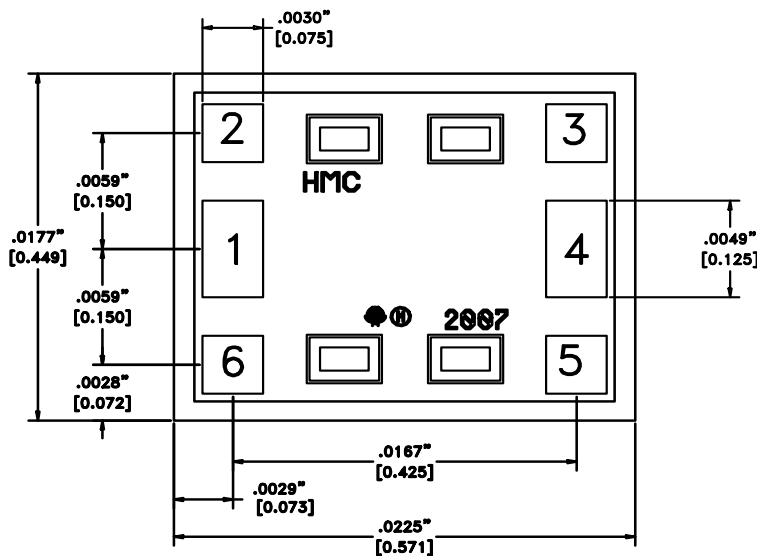

v02.0218

WIDEBAND FIXED ATTENUATOR FAMILY, DC - 50 GHz
HMC650 / 651 / 652 / 653 / 654 / 655 / 656 / 657 / 658

Pad Descriptions

Pad Number	Function	Description	Interface Schematic
1, 2	RF1, RF2	This pad is DC coupled and matched to 50 Ohms. Use DC Blocking capacitors if the input / output signals have non-zero DC potential	
	GND	Die bottom must be connected to RF ground.	

Assembly Diagram

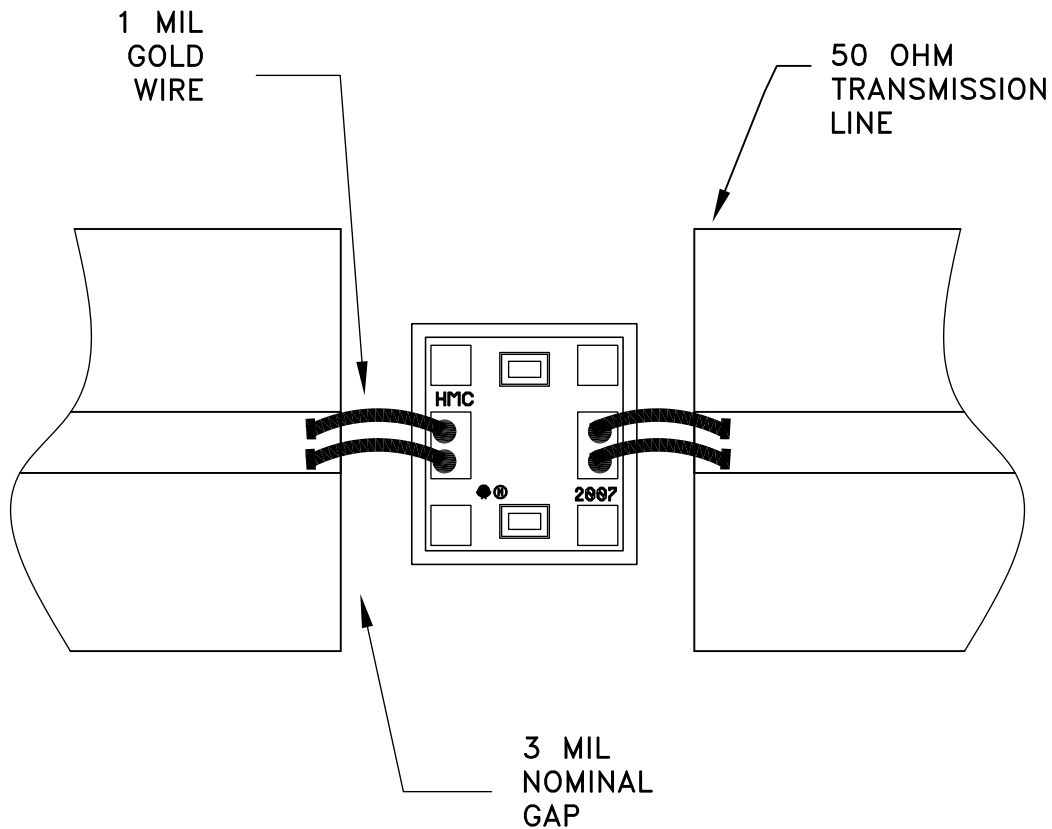

WIDEBAND FIXED ATTENUATOR FAMILY, DC - 50 GHz HMC650 / 651 / 652 / 653 / 654 / 655 / 656 / 657 / 658

Mounting & Bonding Techniques for Millimeterwave GaAs MMICs

The die should be attached directly to the ground plane eutectically or with conductive epoxy (see HMC general Handling, Mounting, Bonding Note).

50 Ohm Microstrip transmission lines on 0.127mm (5 mil) thick alumina thin film substrates are recommended for bringing RF to and from the chip (Figure 1). If 0.254mm (10 mil) thick alumina thin film substrates must be used, the die should be raised 0.150mm (6 mils) so that the surface of the die is coplanar with the surface of the substrate. One way to accomplish this is to attach the 0.102mm (4 mil) thick die to a 0.150mm (6 mil) thick molybdenum heat spreader (moly-tab) which is then attached to the ground plane (Figure 2).

Microstrip substrates should be brought as close to the die as possible in order to minimize bond wire length. Typical die-to-substrate spacing is 0.076mm to 0.152 mm (3 to 6 mils).

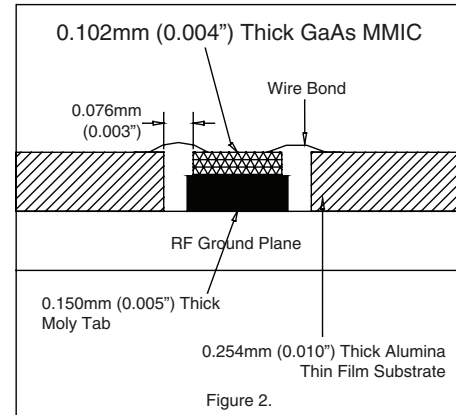
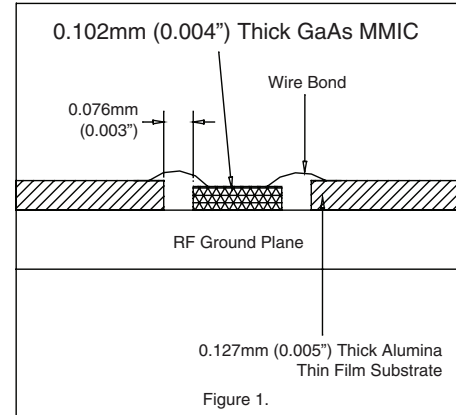

Handling Precautions

Follow these precautions to avoid permanent damage.

Storage: All bare die are placed in either Waffle or Gel based ESD protective containers, and then sealed in an ESD protective bag for shipment. Once the sealed ESD protective bag has been opened, all die should be stored in a dry nitrogen environment.

Cleanliness: Handle the chips in a clean environment. DO NOT attempt to clean the chip using liquid cleaning systems.

Static Sensitivity: Follow ESD precautions to protect against ESD strikes.

Transients: Suppress instrument and bias supply transients while bias is applied. Use shielded signal and bias cables to minimize inductive pick-up.

General Handling: Handle the chip along the edges with a vacuum collet or with a sharp pair of bent tweezers. The surface of the chip has fragile air bridges and should not be touched with vacuum collet, tweezers, or fingers.

Mounting

The chip is back-metallized and can be die mounted with AuSn eutectic preforms or with electrically conductive epoxy. The mounting surface should be clean and flat.

Eutectic Die Attach: A 80/20 gold tin preform is recommended with a work surface temperature of 255 °C and a tool temperature of 265 °C. When hot 90/10 nitrogen/hydrogen gas is applied, tool tip temperature should be 290 °C. DO NOT expose the chip to a temperature greater than 320 °C for more than 20 seconds. No more than 3 seconds of scrubbing should be required for attachment.

Epoxy Die Attach: Apply a minimum amount of epoxy to the mounting surface so that a thin epoxy fillet is observed around the perimeter of the chip once it is placed into position. Cure epoxy per the manufacturer's schedule.

Wire Bonding



Ball or wedge bond with 0.025mm (1 mil) diameter pure gold wire. Thermosonic wirebonding with a nominal stage temperature of 150 °C and a ball bonding force of 40 to 50 grams or wedge bonding force of 18 to 22 grams is recommended. Use the minimum level of ultrasonic energy to achieve reliable wirebonds. Wirebonds should be started on the chip and terminated on the package or substrate. All bonds should be as short as possible <0.31mm (12 mils).

v02.0218

**WIDEBAND FIXED ATTENUATOR FAMILY, DC - 50 GHz
HMC650 / 651 / 652 / 653 / 654 / 655 / 656 / 657 / 658****Notes:**

Looking for pricing, stock, or lifecycle information?

Click below to explore more details on WIN SOURCE:

-  [View HMC658 on WIN SOURCE](#)
-  [Analog Devices Inc. Information](#)

Optimize Your Supply Chain with WIN SOURCE Solutions

-  Global Sourcing Solution
-  Obsolete Management
-  Cost Control Management
-  Shortage Management
-  Alternative Solution
-  Excess Inventory Management