



**THE DATASHEET OF  
5M240ZM68C4N**





## MAX V Device Handbook

---



101 Innovation Drive  
San Jose, CA 95134  
[www.altera.com](http://www.altera.com)



Subscribe

© 2017 Altera Corporation. All rights reserved. ALTERA, ARRIA, CYCLONE, HARDCOPY, MAX, MEGACORE, NIOS, QUARTUS and STRATIX are Reg. U.S. Pat. & Tm. Off. and/or trademarks of Altera Corporation in the U.S. and other countries. All other trademarks and service marks are the property of their respective holders as described at [www.altera.com/common/legal.html](http://www.altera.com/common/legal.html). Altera warrants performance of its semiconductor products to current specifications in accordance with Altera's standard warranty, but reserves the right to make changes to any products and services at any time without notice. Altera assumes no responsibility or liability arising out of the application or use of any information, product, or service described herein except as expressly agreed to in writing by Altera. Altera customers are advised to obtain the latest version of device specifications before relying on any published information and before placing orders for products or services.



## Section I. MAX V Device Core

### Chapter 1. MAX V Device Family Overview

Feature Summary	1-1
Integrated Software Platform	1-3
Device Pin-Outs	1-3
Ordering Information	1-4
Document Revision History	1-4

### Chapter 2. MAX V Architecture

Functional Description	2-1
Logic Array Blocks	2-4
LAB Interconnects	2-6
LAB Control Signals	2-6
Logic Elements	2-8
LUT Chain and Register Chain	2-9
addsub Signal	2-9
LE Operating Modes	2-9
Normal Mode	2-10
Dynamic Arithmetic Mode	2-10
Carry-Select Chain	2-11
Clear and Preset Logic Control	2-13
LE RAM	2-13
MultiTrack Interconnect	2-14
Global Signals	2-19
User Flash Memory Block	2-21
UFM Storage	2-22
Internal Oscillator	2-22
Program, Erase, and Busy Signals	2-23
Auto-Increment Addressing	2-23
Serial Interface	2-23
UFM Block to Logic Array Interface	2-24
Core Voltage	2-25
I/O Structure	2-26
Fast I/O Connection	2-27
I/O Blocks	2-28
I/O Standards and Banks	2-29
PCI Compliance	2-32
LVDS and RSDS Channels	2-32
Schmitt Trigger	2-32
Output Enable Signals	2-33
Programmable Drive Strength	2-33
Slew-Rate Control	2-34
Open-Drain Output	2-34
Programmable Ground Pins	2-34
Bus-Hold	2-34
Programmable Pull-Up Resistor	2-35
Programmable Input Delay	2-35

MultiVolt I/O Interface .....	2–35
Document Revision History .....	2–36

### Chapter 3. DC and Switching Characteristics for MAX V Devices

Operating Conditions .....	3–1
Absolute Maximum Ratings .....	3–1
Recommended Operating Conditions .....	3–2
Programming/Erase Specifications .....	3–3
DC Electrical Characteristics .....	3–3
Output Drive Characteristics .....	3–5
I/O Standard Specifications .....	3–5
Bus Hold Specifications .....	3–8
Power-Up Timing .....	3–9
Power Consumption .....	3–10
Timing Model and Specifications .....	3–10
Preliminary and Final Timing .....	3–11
Performance .....	3–11
Internal Timing Parameters .....	3–12
External Timing Parameters .....	3–19
External Timing I/O Delay Adders .....	3–23
Maximum Input and Output Clock Rates .....	3–26
LVDS and RSDS Output Timing Specifications .....	3–27
JTAG Timing Specifications .....	3–29
Document Revision History .....	3–30

## Section II. System Integration in MAX V Devices

### Chapter 4. Hot Socketing and Power-On Reset in MAX V Devices

MAX V Hot-Socketing Specifications .....	4–1
Devices Can Be Driven Before Power Up .....	4–2
I/O Pins Remain Tri-States During Power Up .....	4–2
Signal Pins Do Not Drive the V <sub>CCIO</sub> or V <sub>CCINT</sub> Power Supplies .....	4–2
AC and DC Specifications .....	4–2
Hot-Socketing Feature Implementation in MAX V Devices .....	4–3
Power-On Reset Circuitry .....	4–5
Power-Up Characteristics .....	4–5
Document Revision History .....	4–6

### Chapter 5. Using MAX V Devices in Multi-Voltage Systems

I/O Standards .....	5–1
MultiVolt I/O Operation .....	5–3
5.0-V Device Compatibility .....	5–3
Recommended Operating Conditions for 5.0-V Compatibility .....	5–7
Power-Up Sequencing .....	5–8
Document Revision History .....	5–8

### Chapter 6. JTAG and In-System Programmability in MAX V Devices

IEEE Std. 1149.1 Boundary-Scan Support .....	6–1
JTAG Block .....	6–4
Parallel Flash Loader .....	6–4
In-System Programmability .....	6–5
IEEE 1532 Support .....	6–6
Jam Standard Test and Programming Language .....	6–6

Programming Sequence .....	6-6
User Flash Memory Programming .....	6-7
In-System Programming Clamp .....	6-7
Real-Time ISP .....	6-8
Design Security .....	6-8
Programming with External Hardware .....	6-8
Document Revision History .....	6-9

## Chapter 7. User Flash Memory in MAX V Devices

UFM Array Description .....	7-1
Memory Organization Map .....	7-2
Using and Accessing UFM Storage .....	7-2
UFM Functional Description .....	7-3
UFM Address Register .....	7-5
UFM Data Register .....	7-6
UFM Program/Erase Control Block .....	7-6
Oscillator .....	7-7
Instantiating the Oscillator without the UFM .....	7-7
UFM Operating Modes .....	7-8
Read/Stream Read .....	7-9
Program .....	7-10
Erase .....	7-11
Programming and Reading the UFM with JTAG .....	7-12
Jam Files .....	7-12
Jam Players .....	7-12
Software Support for UFM Block .....	7-13
Inter-Integrated Circuit .....	7-13
I <sup>2</sup> C Protocol .....	7-13
Device Addressing .....	7-15
Byte Write Operation .....	7-16
Page Write Operation .....	7-17
Acknowledge Polling .....	7-17
Write Protection .....	7-17
Erase Operation .....	7-17
Read Operation .....	7-20
ALTUFM_I2C Interface Timing Specification .....	7-22
Instantiating the I <sup>2</sup> C Interface Using the Quartus II ALTUFM_I2C Megafunction .....	7-23
Serial Peripheral Interface .....	7-23
Opcodes .....	7-25
ALTUFM SPI Timing Specification .....	7-35
Instantiating SPI Using Quartus II ALTUFM_SPI Megafunction .....	7-35
Parallel Interface .....	7-36
ALTUFM Parallel Interface Timing Specification .....	7-37
Instantiating Parallel Interface Using Quartus II ALTUFM_PARALLEL Megafunction .....	7-37
None (Altera Serial Interface) .....	7-38
Instantiating None Using Quartus II ALTUFM_NONE Megafunction .....	7-38
Creating Memory Content File .....	7-39
Memory Initialization for the ALTUFM_PARALLEL Megafunction .....	7-39
Memory Initialization for the ALTUFM_SPI Megafunction .....	7-39
Memory Initialization for the ALTUFM_I2C Megafunction .....	7-40
Simulation Parameters .....	7-43
Document Revision History .....	7-43

## Chapter 8. JTAG Boundary-Scan Testing in MAX V Devices

IEEE Std. 1149.1 BST Architecture .....	8-2
IEEE Std. 1149.1 Boundary-Scan Register .....	8-3
Boundary-Scan Cells of a MAX V Device I/O Pin .....	8-4
JTAG Pins and Power Pins .....	8-5
IEEE Std. 1149.1 BST Operation Control .....	8-6
SAMPLE/PRELOAD Instruction Mode .....	8-8
EXTEST Instruction Mode .....	8-10
BYPASS Instruction Mode .....	8-12
IDCODE Instruction Mode .....	8-12
USERCODE Instruction Mode .....	8-13
CLAMP Instruction Mode .....	8-13
HIGHZ Instruction Mode .....	8-13
I/O Voltage Support in the JTAG Chain .....	8-13
Boundary-Scan Test for Programmed Devices .....	8-14
Disabling IEEE Std. 1149.1 BST Circuitry .....	8-15
Guidelines for IEEE Std. 1149.1 Boundary-Scan Testing .....	8-15
Boundary-Scan Description Language Support .....	8-15
Document Revision History .....	8-16

## Additional Information

Document Revision History .....	Info-1
How to Contact Altera .....	Info-1
Typographic Conventions .....	Info-1

This section provides a complete overview of all features relating to the MAX<sup>®</sup> V device family.

This section includes the following chapters:

- [Chapter 1, MAX V Device Family Overview](#)
- [Chapter 2, MAX V Architecture](#)
- [Chapter 3, DC and Switching Characteristics for MAX V Devices](#)



The MAX<sup>®</sup> V family of low cost and low power CPLDs offer more density and I/Os per footprint versus other CPLDs. Ranging in density from 40 to 2,210 logic elements (LEs) (32 to 1,700 equivalent macrocells) and up to 271 I/Os, MAX V devices provide programmable solutions for applications such as I/O expansion, bus and protocol bridging, power monitoring and control, FPGA configuration, and analog IC interface.

MAX V devices feature on-chip flash storage, internal oscillator, and memory functionality. With up to 50% lower total power versus other CPLDs and requiring as few as one power supply, MAX V CPLDs can help you meet your low power design requirement.

This chapter contains the following sections:

- [“Feature Summary” on page 1-1](#)
- [“Integrated Software Platform” on page 1-3](#)
- [“Device Pin-Outs” on page 1-3](#)
- [“Ordering Information” on page 1-4](#)

## Feature Summary

The following list summarizes the MAX V device family features:

- Low-cost, low-power, and non-volatile CPLD architecture
- Instant-on (0.5 ms or less) configuration time
- Standby current as low as 25  $\mu$ A and fast power-down/reset operation
- Fast propagation delay and clock-to-output times
- Internal oscillator
- Emulated RSDS output support with a data rate of up to 200 Mbps
- Emulated LVDS output support with a data rate of up to 304 Mbps
- Four global clocks with two clocks available per logic array block (LAB)
- User flash memory block up to 8 Kbits for non-volatile storage with up to 1000 read/write cycles
- Single 1.8-V external supply for device core
- MultiVolt I/O interface supporting 3.3-V, 2.5-V, 1.8-V, 1.5-V, and 1.2-V logic levels
- Bus-friendly architecture including programmable slew rate, drive strength, bus-hold, and programmable pull-up resistors
- Schmitt triggers enabling noise tolerant inputs (programmable per pin)

- I/Os are fully compliant with the PCI-SIG<sup>®</sup> PCI Local Bus Specification, revision 2.2 for 3.3-V operation
- Hot-socket compliant
- Built-in JTAG BST circuitry compliant with IEEE Std. 1149.1-1990

Table 1–1 lists the MAX V family features.

**Table 1–1. MAX V Family Features**

Feature	5M40Z	5M80Z	5M160Z	5M240Z	5M570Z	5M1270Z	5M2210Z
LEs	40	80	160	240	570	1,270	2,210
Typical Equivalent Macrocells	32	64	128	192	440	980	1,700
User Flash Memory Size (bits)	8,192	8,192	8,192	8,192	8,192	8,192	8,192
Global Clocks	4	4	4	4	4	4	4
Internal Oscillator	1	1	1	1	1	1	1
Maximum User I/O pins	54	79	79	114	159	271	271
$t_{PD1}$ (ns) (1)	7.5	7.5	7.5	7.5	9.0	6.2	7.0
$f_{CNT}$ (MHz) (2)	152	152	152	152	152	304	304
$t_{SU}$ (ns)	2.3	2.3	2.3	2.3	2.2	1.2	1.2
$t_{CO}$ (ns)	6.5	6.5	6.5	6.5	6.7	4.6	4.6

**Notes to Table 1–1:**

- (1)  $t_{PD1}$  represents a pin-to-pin delay for the worst case I/O placement with a full diagonal path across the device and combinational logic implemented in a single LUT and LAB that is adjacent to the output pin.
- (2) The maximum global clock frequency,  $f_{CNT}$ , is limited by the I/O standard on the clock input pin. The 16-bit counter critical delay will run faster than this number.

MAX V devices accept 1.8 V on their VCCINT pins. The 1.8-V VCCINT external supply powers the device core directly. MAX V devices operate internally at 1.8 V. The supported MultiVolt I/O interface voltage levels (VCCIO) are 1.2 V, 1.5 V, 1.8 V, 2.5 V, and 3.3 V.

MAX V devices are available in two speed grades: –4 and –5, with –4 being the fastest. For commercial applications, speed grades –C4 and –C5 are available. For industrial and automotive applications, speed grade –I5 and –A5 are available, respectively. These speed grades represent the overall relative performance, not any specific timing parameter.



For propagation delay timing numbers within each speed grade and density, refer to the *DC and Switching Characteristics for MAX V Devices* chapter.

MAX V devices are available in space-saving FineLine BGA (FBGA), Micro FineLine BGA (MBGA), plastic enhanced quad flat pack (EQFP), and thin quad flat pack (TQFP) packages (refer to Table 1–2 and Table 1–3). MAX V devices support vertical migration within the same package (for example, you can migrate between the 5M570Z, 5M1270Z, and 5M2210Z devices in the 256-pin FineLine BGA package). Vertical migration means that you can migrate to devices whose dedicated pins and JTAG pins are the same and power pins are subsets or supersets for a given package across device densities. The largest density in any package has the highest number of power pins; you must lay out for the largest planned density in a package to provide

the necessary power pins for migration. For I/O pin migration across densities, cross reference the available I/O pins using the device pin-outs for all planned densities of a given package type to identify which I/O pins can be migrated. The Quartus® II software can automatically cross-reference and place all pins for you when given a device migration list.

**Table 1–2. MAX V Packages and User I/O Pins (Note 1)**

Device	64-Pin MBGA	64-Pin EQFP	68-Pin MBGA	100-Pin TQFP	100-Pin MBGA	144-Pin TQFP	256-Pin FBGA	324-Pin FBGA
5M40Z	▲ 30	▲ 54	—	—	—	—	—	—
5M80Z	▼ 30	▲ 54	▲ 52	▲ 79	—	—	—	—
5M160Z	—	▼ 54	▲ 52	▲ 79	▲ 79	—	—	—
5M240Z	—	—	▼ 52	▲ 79	▲ 79	▲ 114	—	—
5M570Z	—	—	—	▼ 74	▼ 74	▲ 114	▲ 159	—
5M1270Z	—	—	—	—	—	▼ 114	▲ 211	▲ 271
5M2210Z	—	—	—	—	—	—	▼ 203	▼ 271

**Note to Table 1–2:**

(1) Device packages under the same arrow sign have vertical migration capability.

**Table 1–3. MAX V Package Sizes**

Package	64-Pin MBGA	64-Pin EQFP	68-Pin MBGA	100-Pin TQFP	100-Pin MBGA	144-Pin TQFP	256-Pin FBGA	324-Pin FBGA
Pitch (mm)	0.5	0.4	0.5	0.5	0.5	0.5	1	1
Area (mm <sup>2</sup> )	20.25	81	25	256	36	484	289	361
Length × width (mm × mm)	4.5 × 4.5	9 × 9	5 × 5	16 × 16	6 × 6	22 × 22	17 × 17	19 × 19

## Integrated Software Platform

The Quartus II software provides an integrated environment for HDL and schematic design entry, compilation and logic synthesis, full simulation and advanced timing analysis, and programming of MAX V devices.

 For more information about the Quartus II software features, refer to the *Quartus II Handbook*.

You can debug your MAX V designs using In-System Sources and Probes Editor in the Quartus II software. This feature allows you to easily control any internal signal and provides you with a completely dynamic debugging environment.

 For more information about the In-System Sources and Probes Editor, refer to the *Design Debugging Using In-System Sources and Probes* chapter of the *Quartus II Handbook*.

## Device Pin-Outs

 For more information, refer to the *MAX V Device Pin-Out Files* page.

## Ordering Information

Figure 1-1 shows the ordering codes for MAX V devices.

**Figure 1-1. MAX V Device Packaging Ordering Information**

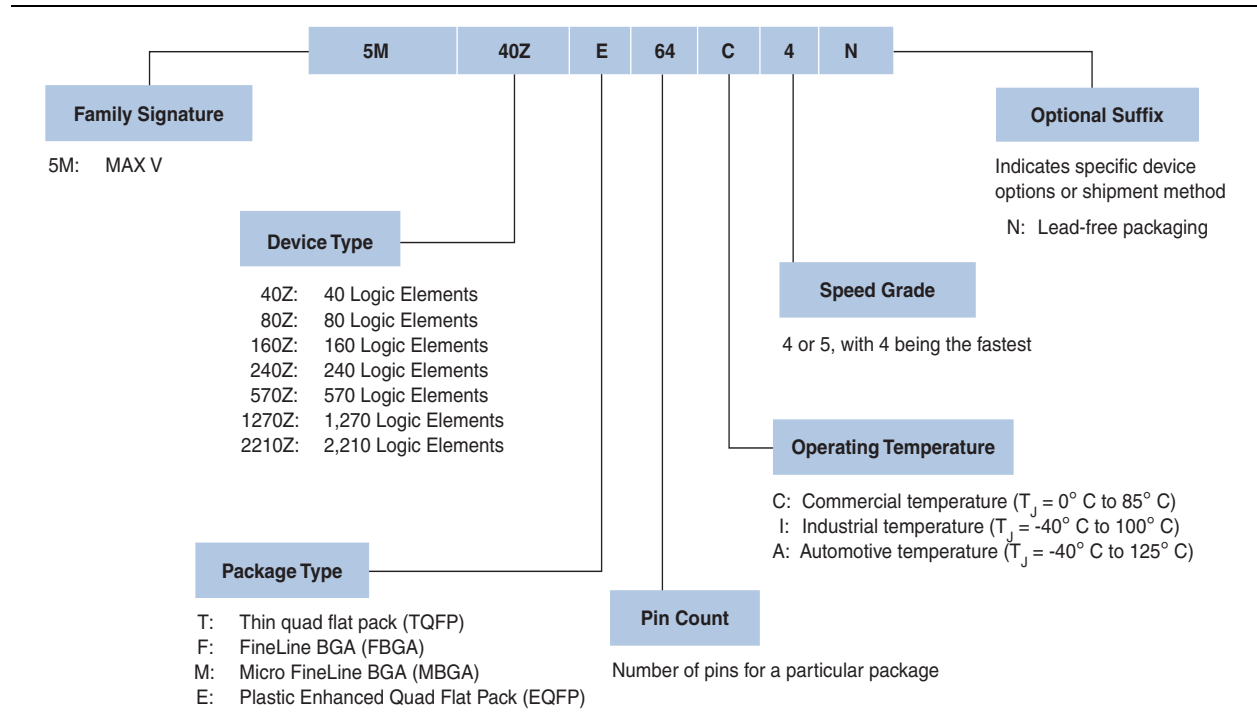

## Document Revision History

Table 1-4 lists the revision history for this chapter.

**Table 1-4. Document Revision History**

Date	Version	Changes
May 2011	1.2	<ul style="list-style-type: none"> <li>Updated Figure 1-1.</li> <li>Updated Table 1-3.</li> </ul>
January 2011	1.1	Updated “Feature Summary” section.
December 2010	1.0	Initial release.

This chapter describes the architecture of the MAX<sup>®</sup> V device and contains the following sections:

- “Functional Description” on page 2–1
- “Logic Array Blocks” on page 2–4
- “Logic Elements” on page 2–8
- “MultiTrack Interconnect” on page 2–14
- “Global Signals” on page 2–19
- “User Flash Memory Block” on page 2–21
- “Internal Oscillator” on page 2–22
- “Core Voltage” on page 2–25
- “I/O Structure” on page 2–26

## Functional Description

MAX V devices contain a two-dimensional row- and column-based architecture to implement custom logic. Row and column interconnects provide signal interconnects between the logic array blocks (LABs).

Each LAB in the logic array contains 10 logic elements (LEs). An LE is a small unit of logic that provides efficient implementation of user logic functions. LABs are grouped into rows and columns across the device. The MultiTrack interconnect provides fast granular timing delays between LABs. The fast routing between LEs provides minimum timing delay for added levels of logic versus globally routed interconnect structures.

The I/O elements (IOEs) located after the LAB rows and columns around the periphery of the MAX V device feeds the I/O pins. Each IOE contains a bidirectional I/O buffer with several advanced features. I/O pins support Schmitt trigger inputs and various single-ended standards, such as 33-MHz, 32-bit PCI<sup>™</sup>, and LVTTTL.

MAX V devices provide a global clock network. The global clock network consists of four global clock lines that drive throughout the entire device, providing clocks for all resources within the device. You can also use the global clock lines for control signals such as clear, preset, or output enable.

Figure 2-1 shows a functional block diagram of the MAX V device.

Figure 2-1. Device Block Diagram

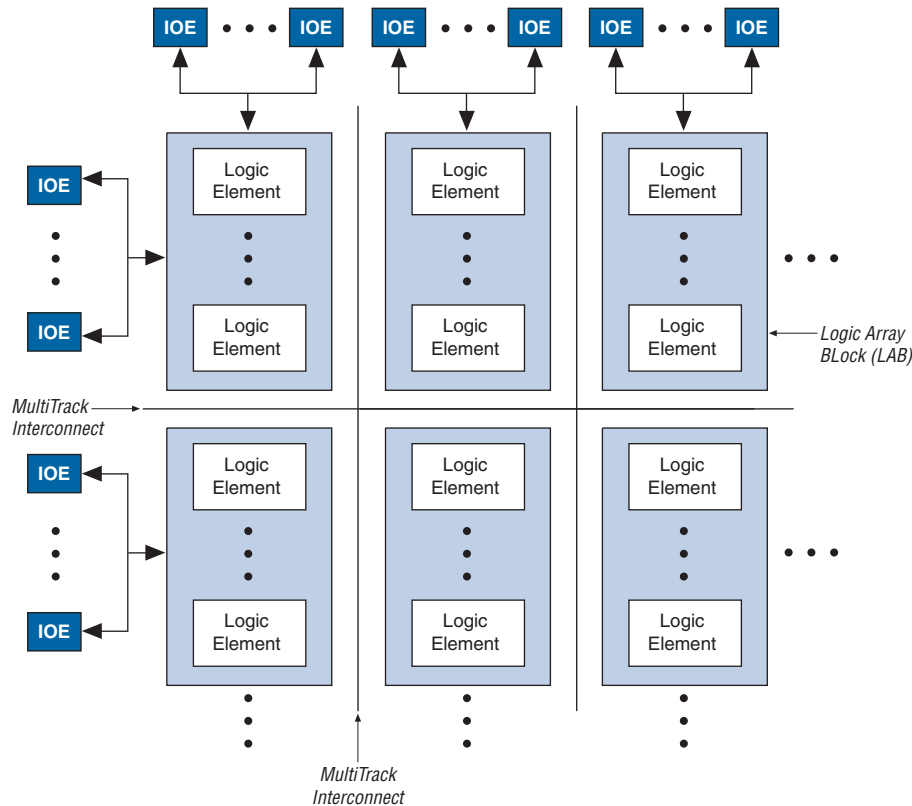

Each MAX V device contains a flash memory block within its floorplan. This block is located on the left side of the 5M40Z, 5M80Z, 5M160Z, and 5M240Z devices. On the 5M240Z (T144 package), 5M570Z, 5M1270Z, and 5M2210Z devices, the flash memory block is located on the bottom-left area of the device. The majority of this flash memory storage is partitioned as the dedicated configuration flash memory (CFM) block. The CFM block provides the non-volatile storage for all of the SRAM configuration information. The CFM automatically downloads and configures the logic and I/O at power-up, providing instant-on operation.

 For more information about configuration upon power-up, refer to the *Hot Socketing and Power-On Reset for MAX V Devices* chapter.

A portion of the flash memory within the MAX V device is partitioned into a small block for user data. This user flash memory (UFM) block provides 8,192 bits of general-purpose user storage. The UFM provides programmable port connections to the logic array for reading and writing. There are three LAB rows adjacent to this block, with column numbers varying by device.

Table 2–1 lists the number of LAB rows and columns in each device, as well as the number of LAB rows and columns adjacent to the flash memory area. The long LAB rows are full LAB rows that extend from one side of row I/O blocks to the other. The short LAB rows are adjacent to the UFM block; their length is shown as width in LAB columns.

**Table 2–1. Device Resources for MAX V Devices**

Device	UFM Blocks	LAB Columns	LAB Rows		Total LABs
			Long LAB Rows	Short LAB Rows (Width) (1)	
5M40Z	1	6	4	—	24
5M80Z	1	6	4	—	24
5M160Z	1	6	4	—	24
5M240Z (2)	1	6	4	—	24
5M240Z (3)	1	12	4	3 (3)	57
5M570Z	1	12	4	3 (3)	57
5M1270Z (4)	1	16	7	3 (5)	127
5M1270Z (5)	1	20	10	3 (7)	221
5M2210Z	1	20	10	3 (7)	221

**Notes to Table 2–1:**

- (1) The width is the number of LAB columns in length.
- (2) Not applicable to T144 package of the 5M240Z device.
- (3) Only applicable to T144 package of the 5M240Z device.
- (4) Not applicable to F324 package of the 5M1270Z device.
- (5) Only applicable to F324 package of the 5M1270Z device.

Figure 2-2 shows a floorplan of a MAX V device.

**Figure 2-2. Device Floorplan for MAX V Devices (Note 1)**

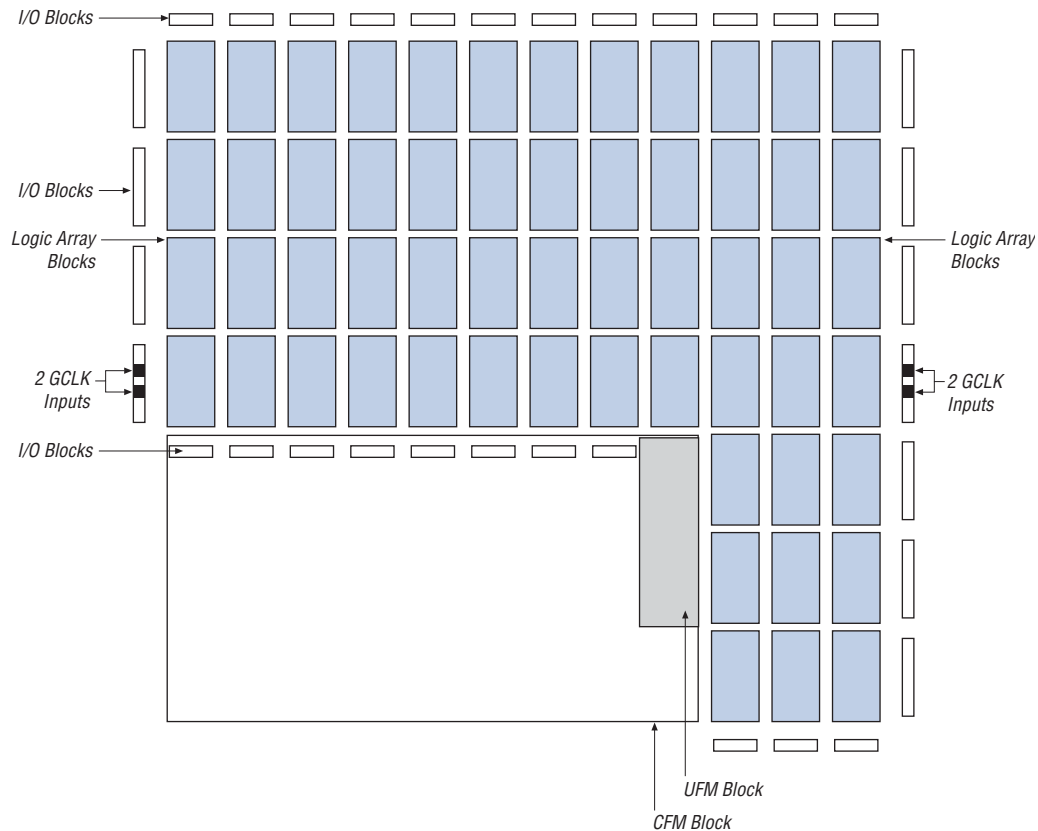

**Note to Figure 2-2:**

- (1) The device shown is a 5M570Z device. 5M1270Z and 5M2210Z devices have a similar floorplan with more LABs. For 5M40Z, 5M80Z, 5M160Z, and 5M240Z devices, the CFM and UFM blocks are located on the left side of the device.

## Logic Array Blocks

Each LAB consists of 10 LEs, LE carry chains, LAB control signals, a local interconnect, a look-up table (LUT) chain, and register chain connection lines. There are 26 possible unique inputs into an LAB, with an additional 10 local feedback input lines fed by LE outputs in the same LAB. The local interconnect transfers signals between LEs in the same LAB. LUT chain connections transfer the LUT output from one LE to the

adjacent LE for fast sequential LUT connections within the same LAB. Register chain connections transfer the output of one LE's register to the adjacent LE's register within an LAB. The Quartus® II software places associated logic within an LAB or adjacent LABs, allowing the use of local, LUT chain, and register chain connections for performance and area efficiency. Figure 2-3 shows the MAX V LAB.

**Figure 2-3. LAB Structure for MAX V Devices**

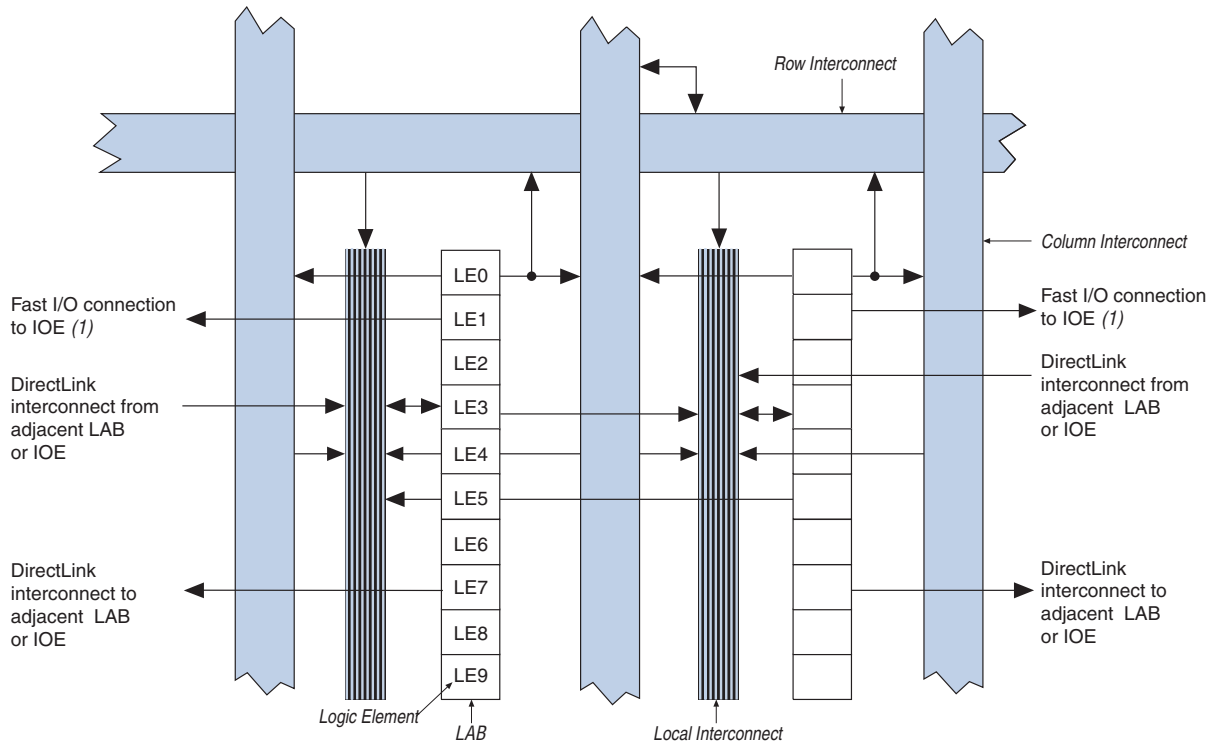

**Note to Figure 2-3:**

(1) Only from LABs adjacent to IOEs.

## LAB Interconnects

Column and row interconnects and LE outputs within the same LAB drive the LAB local interconnect. Adjacent LABs, from the left and right, can also drive an LAB's local interconnect through the DirectLink connection. The DirectLink connection feature minimizes the use of row and column interconnects, providing higher performance and flexibility. Each LE can drive 30 other LEs through fast local and DirectLink interconnects. Figure 2-4 shows the DirectLink connection.

**Figure 2-4. DirectLink Connection**

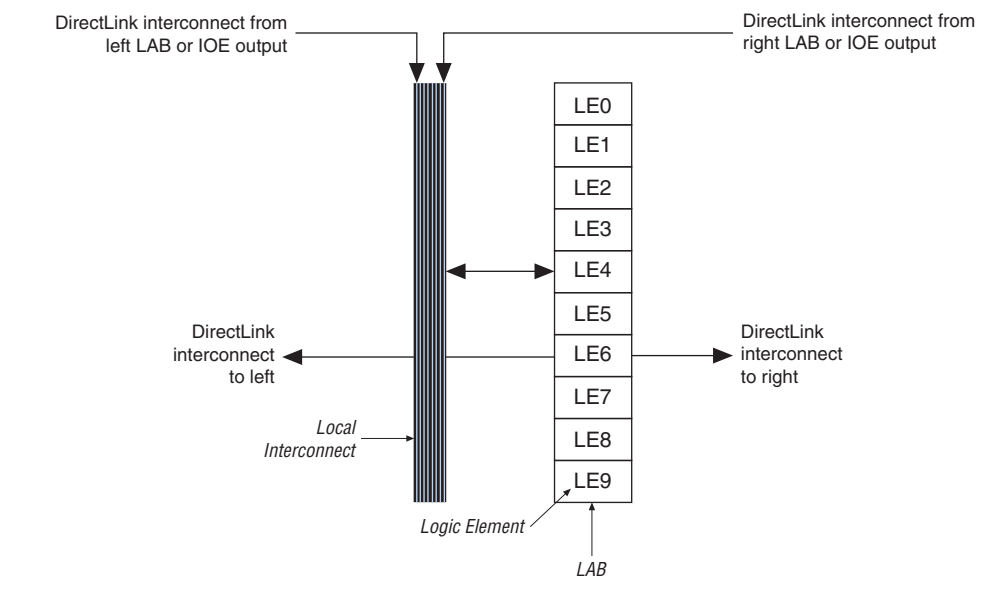

## LAB Control Signals

Each LAB contains dedicated logic for driving control signals to its LEs. The control signals include two clocks, two clock enables, two asynchronous clears, a synchronous clear, an asynchronous preset/load, a synchronous load, and add/subtract control signals, providing a maximum of 10 control signals at a time. Synchronous load and clear signals are generally used when implementing counters but they can also be used with other functions.

Each LAB can use two clocks and two clock enable signals. Each LAB's clock and clock enable signals are linked. For example, any LE in a particular LAB using the `labclk1` signal also uses `labckena1`. If the LAB uses both the rising and falling edges of a clock, it also uses both LAB-wide clock signals. Deasserting the clock enable signal turns off the LAB-wide clock.

Each LAB can use two asynchronous clear signals and an asynchronous load/preset signal. By default, the Quartus II software uses a NOT gate push-back technique to achieve preset. If you disable the NOT gate push-back option or assign a given register to power-up high using the Quartus II software, the preset is then achieved using the asynchronous load signal with asynchronous load data input tied high.

With the LAB-wide addsub control signal, a single LE can implement a one-bit adder and subtractor. This signal saves LE resources and improves performance for logic functions such as correlators and signed multipliers that alternate between addition and subtraction depending on data.

The LAB column clocks [3..0], driven by the global clock network, and LAB local interconnect generate the LAB-wide control signals. The MultiTrack interconnect structure drives the LAB local interconnect for non-global control signal generation. The MultiTrack interconnect's inherent low skew allows clock and control signal distribution in addition to data signals. Figure 2-5 shows the LAB control signal generation circuit.

Figure 2-5. LAB-Wide Control Signals

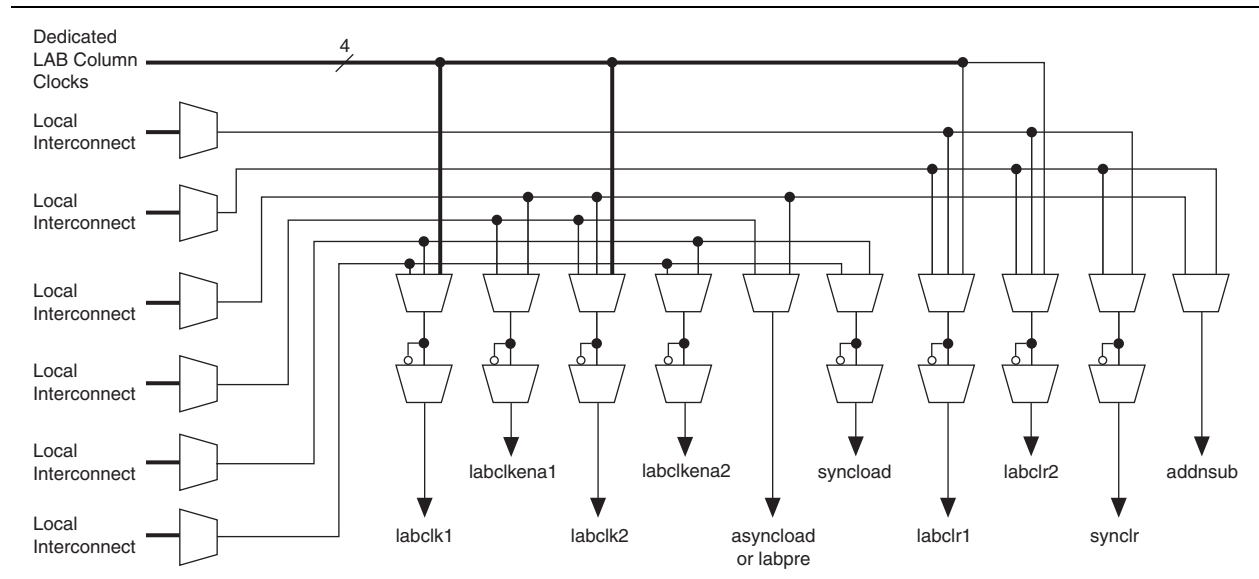

## Logic Elements

The smallest unit of logic in the MAX V architecture, the LE, is compact and provides advanced features with efficient logic utilization. Each LE contains a four-input LUT, which is a function generator that can implement any function of four variables. In addition, each LE contains a programmable register and carry chain with carry-select capability. A single LE also supports dynamic single-bit addition or subtraction mode that is selected by an LAB-wide control signal. Each LE drives all types of interconnects: local, row, column, LUT chain, register chain, and DirectLink interconnects as shown in Figure 2-6.

**Figure 2-6. LE for MAX V Devices**

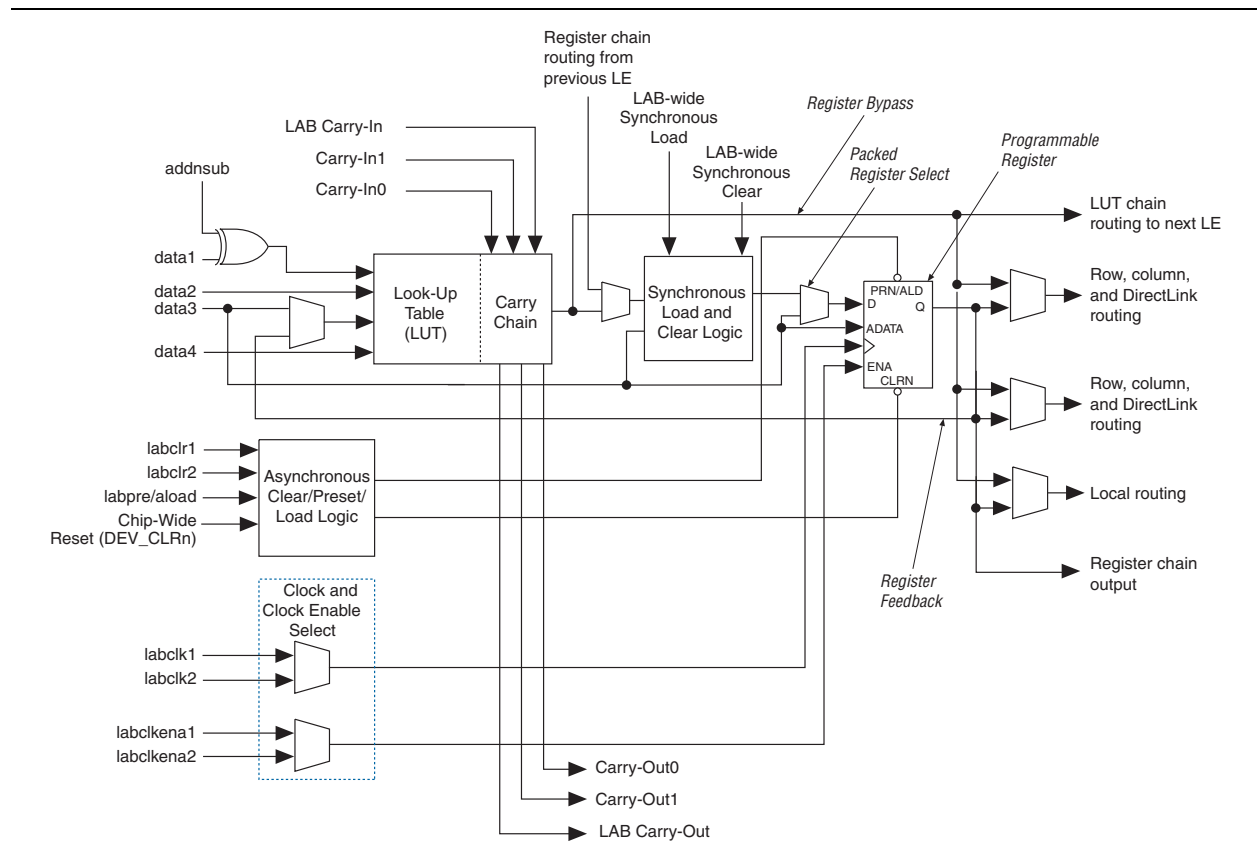

You can configure each LE's programmable register for D, T, JK, or SR operation. Each register has data, true asynchronous load data, clock, clock enable, clear, and asynchronous load/preset inputs. Global signals, general purpose I/O (GPIO) pins, or any LE can drive the register's clock and clear control signals. Either GPIO pins or LEs can drive the clock enable, preset, asynchronous load, and asynchronous data. The asynchronous load data input comes from the data3 input of the LE. For combinational functions, the LUT output bypasses the register and drives directly to the LE outputs.

Each LE has three outputs that drive the local, row, and column routing resources. The LUT or register output can drive these three outputs independently. Two LE outputs drive either a column or row and DirectLink routing connections while one output drives the local interconnect resources. This configuration allows the LUT to drive one output while the register drives another output. This register packing feature

improves device utilization because the device can use the register and the LUT for unrelated functions. Another special packing mode allows the register output to feed back into the LUT of the same LE so that the register is packed with its own fan-out LUT. This mode provides another mechanism for improved fitting. The LE can also drive out registered and unregistered versions of the LUT output.

## LUT Chain and Register Chain

In addition to the three general routing outputs, the LEs within a LAB have LUT chain and register chain outputs. LUT chain connections allow LUTs within the same LAB to cascade together for wide input functions. Register chain outputs allow registers within the same LAB to cascade together. The register chain output allows a LAB to use LUTs for a single combinational function and the registers for an unrelated shift register implementation. These resources speed up connections between LABs while saving local interconnect resources. For more information about LUT chain and register chain connections, refer to [“MultiTrack Interconnect” on page 2-14](#).

## addnsub Signal

The LE's dynamic adder/subtractor feature saves logic resources by using one set of LEs to implement both an adder and a subtractor. This feature is controlled by the LAB-wide control signal `addnsub`. The `addnsub` signal sets the LAB to perform either  $A + B$  or  $A - B$ . The LUT computes addition; subtraction is computed by adding the two's complement of the intended subtractor. The LAB-wide signal converts to two's complement by inverting the B bits within the LAB and setting carry-in to 1, which adds one to the LSB. The LSB of an adder/subtractor must be placed in the first LE of the LAB, where the LAB-wide `addnsub` signal automatically sets the carry-in to 1. The Quartus II Compiler automatically places and uses the adder/subtractor feature when using adder/subtractor parameterized functions.

## LE Operating Modes

The MAX V LE can operate in one of the following modes:

- “Normal Mode”
- “Dynamic Arithmetic Mode”

Each mode uses LE resources differently. In each mode, eight available inputs to the LE, the four data inputs from the LAB local interconnect, `carry-in0` and `carry-in1` from the previous LE, the LAB carry-in from the previous carry-chain LAB, and the register chain connection are directed to different destinations to implement the desired logic function. LAB-wide signals provide clock, asynchronous clear, asynchronous preset/load, synchronous clear, synchronous load, and clock enable control for the register. These LAB-wide signals are available in all LE modes. The `addnsub` control signal is allowed in arithmetic mode.

The Quartus II software, along with parameterized functions such as the library of parameterized modules (LPM) functions, automatically chooses the appropriate mode for common functions such as counters, adders, subtractors, and arithmetic functions.



The other two LUTs use the data1 and data2 signals to generate two possible carry-out signals: one for a carry of 1 and the other for a carry of 0. The carry-in0 signal acts as the carry-select for the carry-out0 output and carry-in1 acts as the carry-select for the carry-out1 output. LEs in arithmetic mode can drive out registered and unregistered versions of the LUT output.

The dynamic arithmetic mode also offers clock enable, counter enable, synchronous up/down control, synchronous clear, synchronous load, and dynamic adder/subtractor options. The LAB local interconnect data inputs generate the counter enable and synchronous up/down control signals. The synchronous clear and synchronous load options are LAB-wide signals that affect all registers in the LAB. The Quartus II software automatically places any registers that are not used by the counter into other LABs. The addsub LAB-wide signal controls whether the LE acts as an adder or subtractor.

**Figure 2-8. LE in Dynamic Arithmetic Mode**

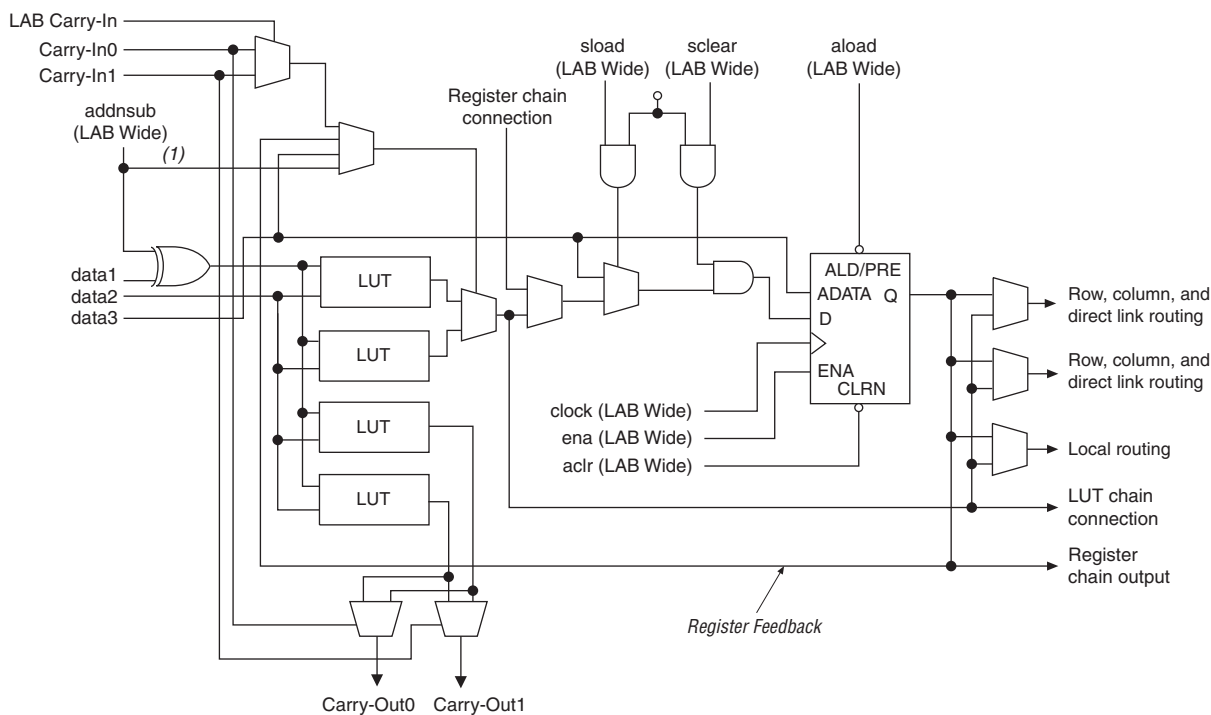

**Note to Figure 2-8:**

(1) The addsub signal is tied to the carry input for the first LE of a carry chain only.

### Carry-Select Chain

The carry-select chain provides a very fast carry-select function between LEs in dynamic arithmetic mode. The carry-select chain uses the redundant carry calculation to increase the speed of carry functions. The LE is configured to calculate outputs for a possible carry-in of 0 and carry-in of 1 in parallel. The carry-in0 and carry-in1 signals from a lower-order bit feed forward into the higher-order bit via the parallel carry chain and feed into both the LUT and the next portion of the carry chain. Carry-select chains can begin in any LE within an LAB.

The speed advantage of the carry-select chain is in the parallel pre-computation of carry chains. Because the LAB carry-in selects the precomputed carry chain, not every LE is in the critical path. Only the propagation delays between LAB carry-in generation (LE5 and LE10) are now part of the critical path. This feature allows the MAX V architecture to implement high-speed counters, adders, multipliers, parity functions, and comparators of arbitrary width.

Figure 2-9 shows the carry-select circuitry in an LAB for a 10-bit full adder. One portion of the LUT generates the sum of two bits using the input signals and the appropriate carry-in bit; the sum is routed to the output of the LE. The register can be bypassed for simple adders or used for accumulator functions. Another portion of the LUT generates carry-out bits. An LAB-wide carry-in bit selects which chain is used for the addition of given inputs. The carry-in signal for each chain, carry-in0 or carry-in1, selects the carry-out to carry forward to the carry-in signal of the next-higher-order bit. The final carry-out signal is routed to an LE, where it is fed to local, row, or column interconnects.

**Figure 2-9. Carry-Select Chain**

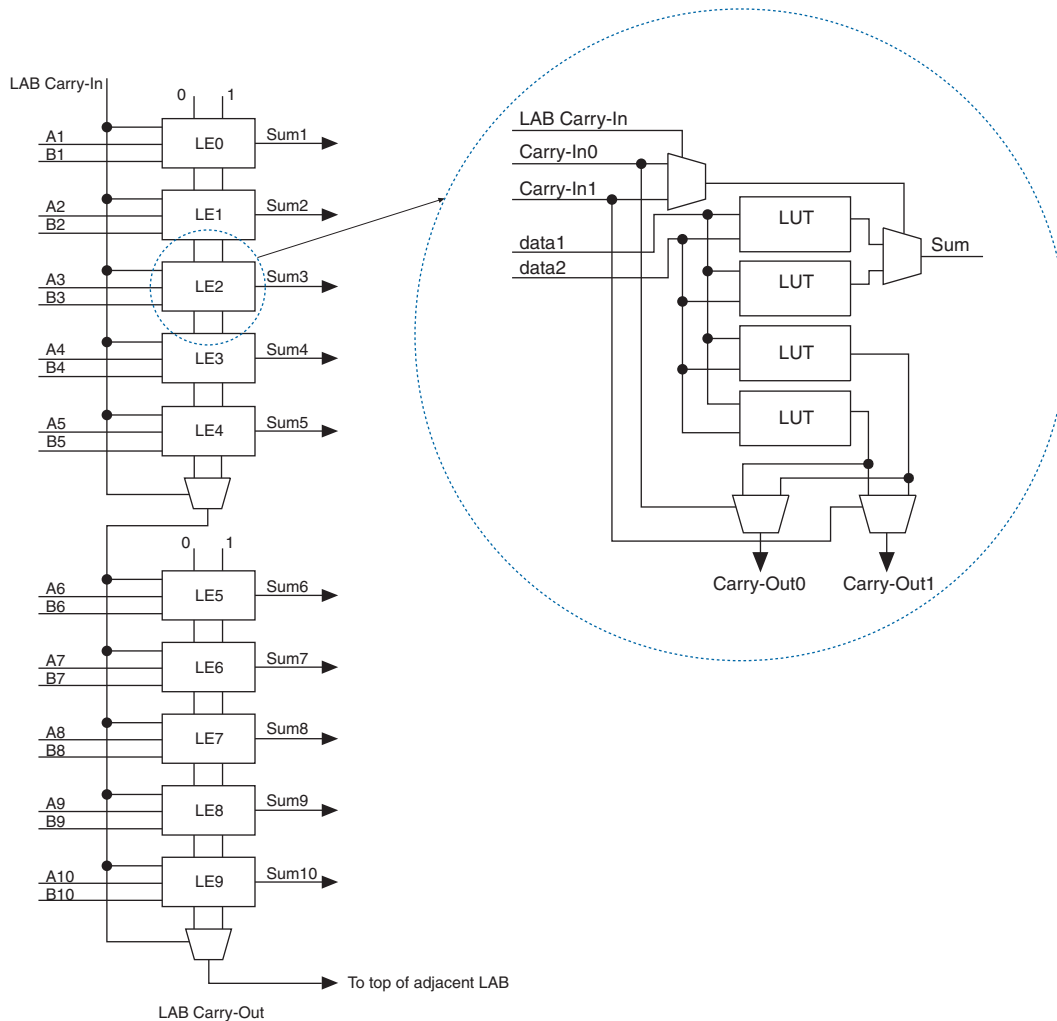

The Quartus II software automatically creates carry chain logic during design processing, or you can create it manually during design entry. Parameterized functions such as LPM functions automatically take advantage of carry chains for the appropriate functions. The Quartus II software creates carry chains longer than 10 LEs by linking adjacent LABs within the same row together automatically. A carry chain can extend horizontally up to one full LAB row, but does not extend between LAB rows.

### Clear and Preset Logic Control

LAB-wide signals control the logic for the register's clear and preset signals. The LE directly supports an asynchronous clear and preset function. The register preset is achieved through the asynchronous load of a logic high. MAX V devices support simultaneous preset/asynchronous load and clear signals. An asynchronous clear signal takes precedence if both signals are asserted simultaneously. Each LAB supports up to two clears and one preset signal.

In addition to the clear and preset ports, MAX V devices provide a chip-wide reset pin (`DEV_CLRn`) that resets all registers in the device. An option set before compilation in the Quartus II software controls this pin. This chip-wide reset overrides all other control signals and uses its own dedicated routing resources without using any of the four global resources. Driving this signal low before or during power-up prevents user mode from releasing clears within the design. This allows you to control when clear is released on a device that has just been powered-up. If not set for its chip-wide reset function, the `DEV_CLRn` pin is a regular I/O pin.

By default, all registers in MAX V devices are set to power-up low. However, this power-up state can be set to high on individual registers during design entry using the Quartus II software.

## LE RAM

The Quartus II memory compiler can configure the unused LEs as LE RAM.

MAX V devices support the following memory types:

- FIFO synchronous R/W
- FIFO asynchronous R/W
- 1 port SRAM
- 2 port SRAM
- 3 port SRAM
- shift registers



For more information about memory, refer to the *Internal Memory (RAM and ROM) User Guide*.

## MultiTrack Interconnect

In the MAX V architecture, connections between LEs, the UFM, and device I/O pins are provided by the MultiTrack interconnect structure. The MultiTrack interconnect consists of continuous, performance-optimized routing lines used for inter- and intra-design block connectivity. The Quartus II Compiler automatically places critical design paths on faster interconnects to improve design performance.

The MultiTrack interconnect consists of row and column interconnects that span fixed distances. A routing structure with fixed length resources for all devices allows predictable and short delays between logic levels instead of large delays associated with global or long routing lines. Dedicated row interconnects route signals to and from LABs within the same row. These row resources include:

- DirectLink interconnects between LABs
- R4 interconnects traversing four LABs to the right or left

The DirectLink interconnect allows an LAB to drive into the local interconnect of its left and right neighbors. The DirectLink interconnect provides fast communication between adjacent LABs and blocks without using row interconnect resources.

The R4 interconnects span four LABs and are used for fast row connections in a four-LAB region. Every LAB has its own set of R4 interconnects to drive either left or right. [Figure 2-10](#) shows R4 interconnect connections from an LAB. R4 interconnects can drive and be driven by row IOEs. For LAB interfacing, a primary LAB or horizontal LAB neighbor can drive a given R4 interconnect. For R4 interconnects that drive to the right, the primary LAB and right neighbor can drive on to the interconnect. For R4 interconnects that drive to the left, the primary LAB and its left neighbor can drive on to the interconnect. R4 interconnects can drive other R4 interconnects to extend the range of LABs they can drive. R4 interconnects can also drive C4 interconnects for connections from one row to another.

**Figure 2-10. R4 Interconnect Connections**

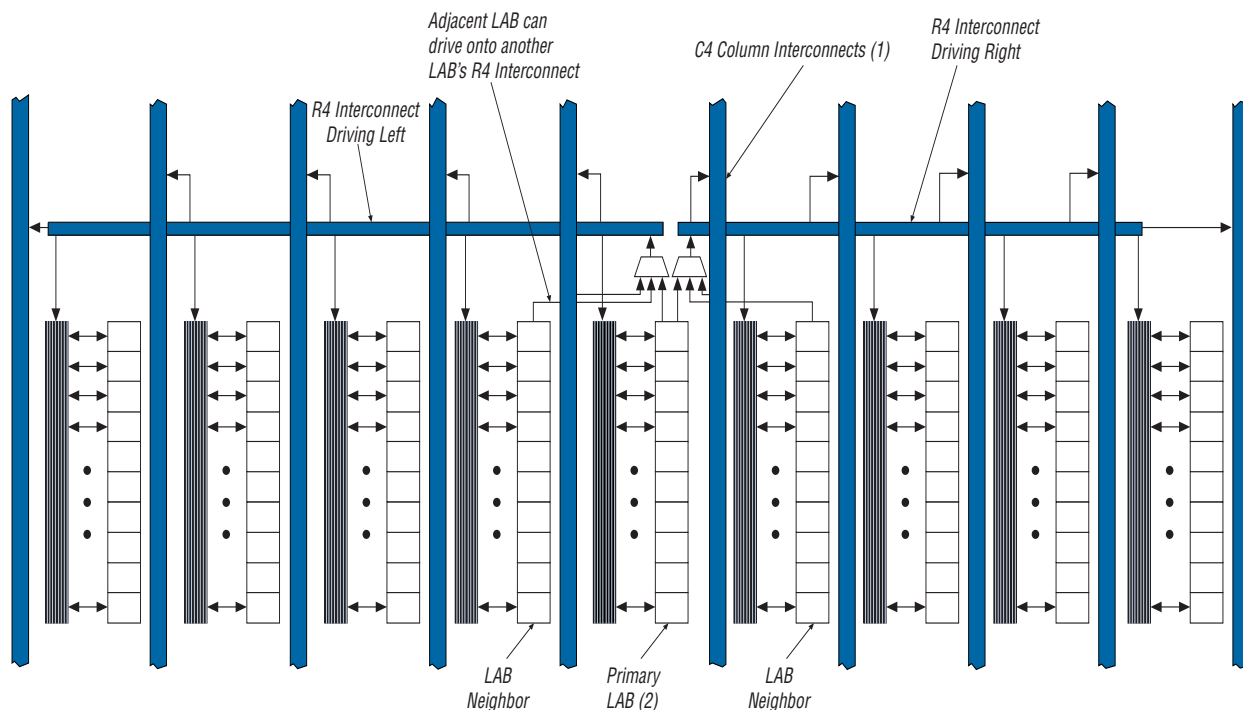

**Notes to Figure 2-10:**

- (1) C4 interconnects can drive R4 interconnects.
- (2) This pattern is repeated for every LAB in the LAB row.

The column interconnect operates similarly to the row interconnect. Each column of LABs is served by a dedicated column interconnect, which vertically routes signals to and from LABs and row and column IOEs. These column resources include:

- LUT chain interconnects within an LAB
- Register chain interconnects within an LAB
- C4 interconnects traversing a distance of four LABs in an up and down direction

MAX V devices include an enhanced interconnect structure within LABs for routing LE output to LE input connections faster using LUT chain connections and register chain connections. The LUT chain connection allows the combinational output of an LE to directly drive the fast input of the LE right below it, bypassing the local interconnect. These resources can be used as a high-speed connection for wide fan-in functions from LE 1 to LE 10 in the same LAB. The register chain connection allows the register output of one LE to connect directly to the register input of the next LE in the LAB for fast shift registers. The Quartus II Compiler automatically takes advantage of these resources to improve utilization and performance. Figure 2-11 shows the LUT chain and register chain interconnects.

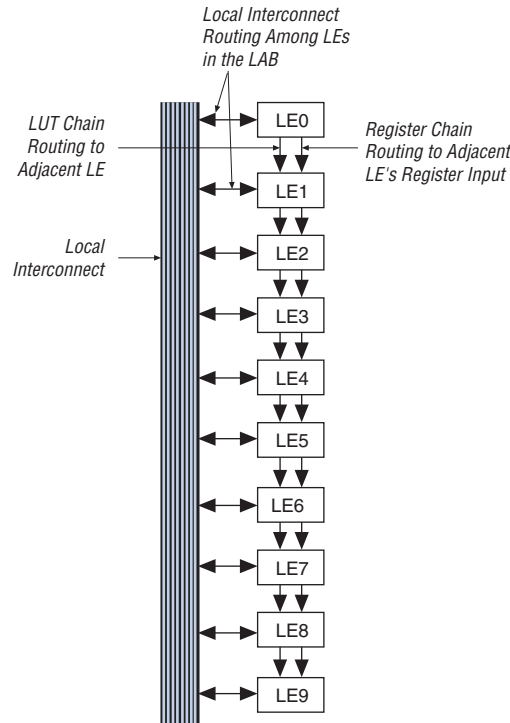
**Figure 2-11. LUT Chain and Register Chain Interconnects**

The C4 interconnects span four LABs up or down from a source LAB. Every LAB has its own set of C4 interconnects to drive either up or down. [Figure 2-12](#) shows the C4 interconnect connections from an LAB in a column. The C4 interconnects can drive and be driven by column and row IOEs. For LAB interconnection, a primary LAB or its vertical LAB neighbor can drive a given C4 interconnect. C4 interconnects can drive each other to extend their range as well as drive row interconnects for column-to-column connections.

Figure 2-12. C4 Interconnect Connections (Note 1)

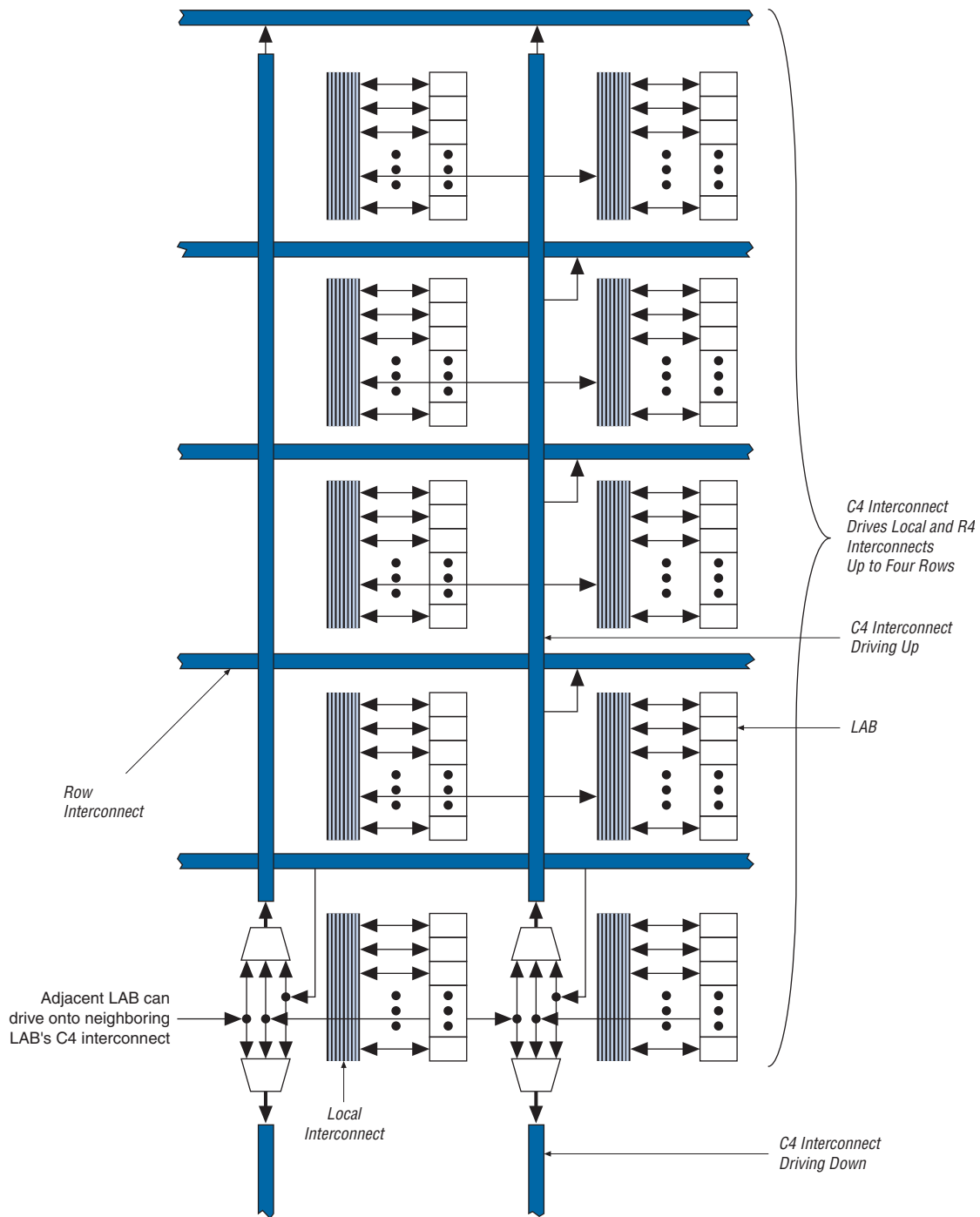

**Note to Figure 2-12:**

- (1) Each C4 interconnect can drive either up or down four rows.

The UFM block communicates with the logic array similar to LAB-to-LAB interfaces. The UFM block connects to row and column interconnects and has local interconnect regions driven by row and column interconnects. This block also has DirectLink interconnects for fast connections to and from a neighboring LAB. For more information about the UFM interface to the logic array, refer to “User Flash Memory Block” on page 2-21.

Table 2-2 lists the MAX V device routing scheme.

**Table 2-2. Routing Scheme for MAX V Devices**

Source	Destination										
	LUT Chain	Register Chain	Local (1)	DirectLink (1)	R4 (1)	C4 (1)	LE	UFM Block	Column IOE	Row IOE	Fast I/O (1)
LUT Chain	—	—	—	—	—	—	✓	—	—	—	—
Register Chain	—	—	—	—	—	—	✓	—	—	—	—
Local Interconnect	—	—	—	—	—	—	✓	✓	✓	✓	—
DirectLink Interconnect	—	—	✓	—	—	—	—	—	—	—	—
R4 Interconnect	—	—	✓	—	✓	✓	—	—	—	—	—
C4 Interconnect	—	—	✓	—	✓	✓	—	—	—	—	—
LE	✓	✓	✓	✓	✓	✓	—	—	✓	✓	✓
UFM Block	—	—	✓	✓	✓	✓	—	—	—	—	—
Column IOE	—	—	—	—	—	✓	—	—	—	—	—
Row IOE	—	—	—	✓	✓	✓	—	—	—	—	—

**Note to Table 2-2:**

(1) These categories are interconnects.

## Global Signals

Each MAX V device has four dual-purpose dedicated clock pins (GCLK [3 . . 0], two pins on the left side and two pins on the right side) that drive the global clock network for clocking, as shown in [Figure 2-13](#). These four pins can also be used as GPIOs if they are not used to drive the global clock network.

The four global clock lines in the global clock network drive throughout the entire device. The global clock network can provide clocks for all resources within the device including LEs, LAB local interconnect, IOEs, and the UFM block. The global clock lines can also be used for global control signals, such as clock enables, synchronous or asynchronous clears, presets, output enables, or protocol control signals such as TRDY and IRDY for the PCI I/O standard. Internal logic can drive the global clock network for internally-generated global clocks and control signals. [Figure 2-13](#) shows the various sources that drive the global clock network.

**Figure 2-13. Global Clock Generation**

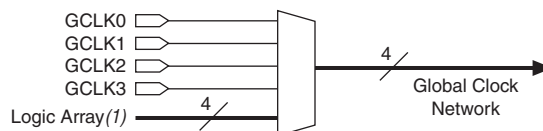

**Note to [Figure 2-13](#):**

(1) Any I/O pin can use a MultiTrack interconnect to route as a logic array-generated global clock signal.

The global clock network drives to individual LAB column signals, LAB column clocks [3 . . 0], that span an entire LAB column from the top to the bottom of the device. Unused global clocks or control signals in an LAB column are turned off at the LAB column clock buffers shown in [Figure 2-14](#). The LAB column clocks [3 . . 0] are multiplexed down to two LAB clock signals and one LAB clear signal. Other control signal types route from the global clock network into the LAB local interconnect. For more information, refer to [“LAB Control Signals”](#) on page 2-6.

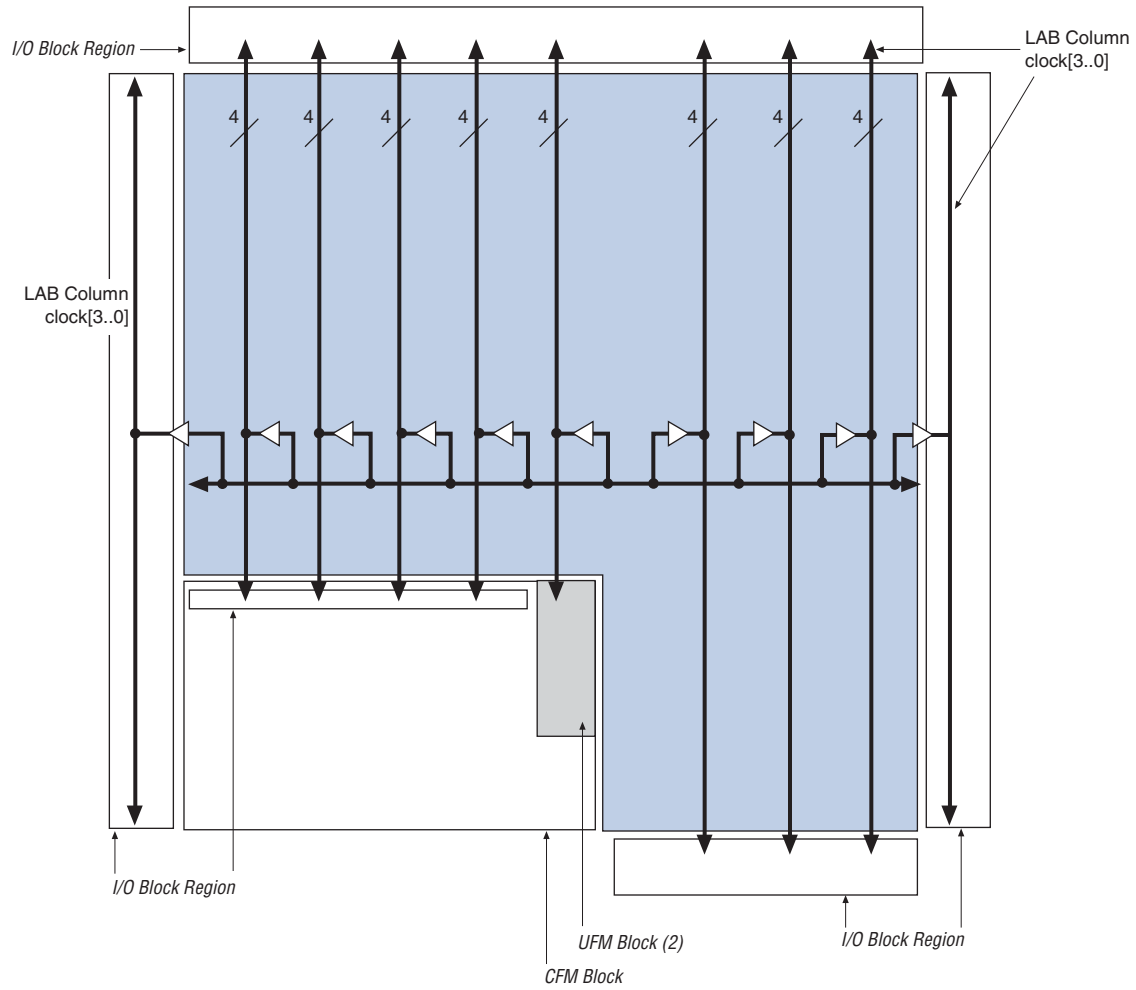
**Figure 2-14. Global Clock Network (Note 1)****Notes to Figure 2-14:**

- (1) LAB column clocks in I/O block regions provide high fan-out output enable signals.
- (2) LAB column clocks drive to the UFM block.

## User Flash Memory Block

MAX V devices feature a single UFM block, which can be used like a serial EEPROM for storing non-volatile information up to 8,192 bits. The UFM block connects to the logic array through the MultiTrack interconnect, allowing any LE to interface to the UFM block. Figure 2-15 shows the UFM block and interface signals. The logic array is used to create customer interface or protocol logic to interface the UFM block data outside of the device. The UFM block offers the following features:

- Non-volatile storage up to 16-bit wide and 8,192 total bits
- Two sectors for partitioned sector erase
- Built-in internal oscillator that optionally drives logic array
- Program, erase, and busy signals
- Auto-increment addressing
- Serial interface to logic array with programmable interface

**Figure 2-15. UFM Block and Interface Signals**

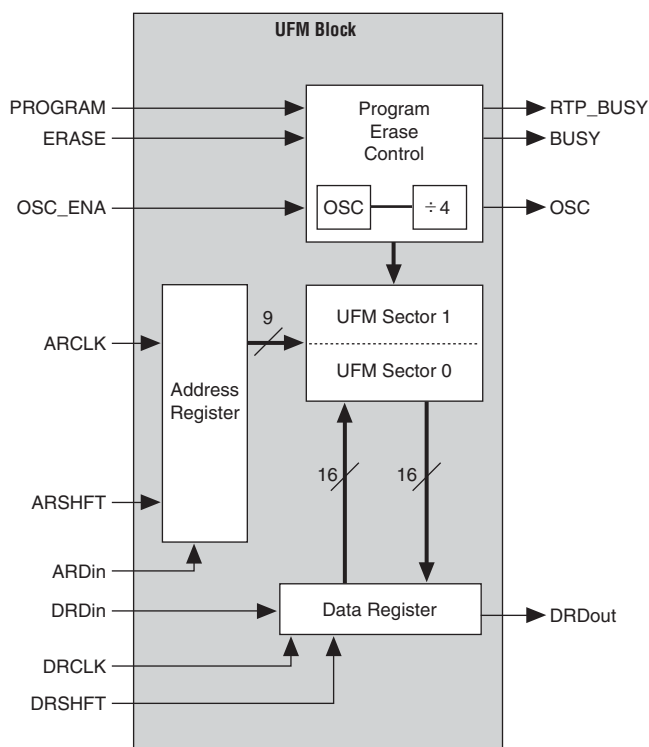

## UFM Storage

Each device stores up to 8,192 bits of data in the UFM block. Table 2-3 lists the data size, sector, and address sizes for the UFM block.

**Table 2-3. UFM Array Size**

Device	Total Bits	Sectors	Address Bits	Data Width
5M40Z	8,192	2 (4,096 bits per sector)	9	16
5M80Z	8,192	2 (4,096 bits per sector)	9	16
5M160Z	8,192	2 (4,096 bits per sector)	9	16
5M240Z	8,192	2 (4,096 bits per sector)	9	16
5M570Z	8,192	2 (4,096 bits per sector)	9	16
5M1270Z	8,192	2 (4,096 bits per sector)	9	16
5M2210Z	8,192	2 (4,096 bits per sector)	9	16

There are 512 locations with 9-bit addressing ranging from 000h to 1FFh. The sector 0 address space is 000h to 0FFh and the sector 1 address space is from 100h to 1FFh. The data width is up to 16 bits of data. The Quartus II software automatically creates logic to accommodate smaller read or program data widths. Erasure of the UFM involves individual sector erasing (that is, one erase of sector 0 and one erase of sector 1 is required to erase the entire UFM block). Because sector erase is required before a program or write operation, having two sectors enables a sector size of data to be left untouched while the other sector is erased and programmed with new data.

## Internal Oscillator

As shown in Figure 2-15, the dedicated circuitry within the UFM block contains an oscillator. The dedicated circuitry uses this oscillator internally for its read and program operations. This oscillator's divide by 4 output can drive out of the UFM block as a logic interface clock source or for general-purpose logic clocking. The typical OSC output signal frequency ranges from 3.9 to 5.3 MHz, and its exact frequency of operation is not programmable.

The UFM internal oscillator can be instantiated using the MegaWizard™ Plug-In Manager. You can also use the MAX II/MAX V Oscillator megafunction to instantiate the UFM oscillator without using the UFM memory block.

## Program, Erase, and Busy Signals

The UFM block's dedicated circuitry automatically generates the necessary internal program and erase algorithm after the PROGRAM or ERASE input signals have been asserted. The PROGRAM or ERASE signal must be asserted until the busy signal deasserts, indicating the UFM internal program or erase operation has completed. The UFM block also supports JTAG as the interface for programming and reading.

 For more information about programming and erasing the UFM block, refer to the *User Flash Memory in MAX V Devices* chapter.

## Auto-Increment Addressing

The UFM block supports standard read or stream read operations. The stream read is supported with an auto-increment address feature. Deasserting the ARSHIFT signal while clocking the ARCLK signal increments the address register value to read consecutive locations from the UFM array.

## Serial Interface

The UFM block supports a serial interface with serial address and data signals. The internal shift registers within the UFM block for address and data are 9 bits and 16 bits wide, respectively. The Quartus II software automatically generates interface logic in LEs for a parallel address and data interface to the UFM block. Other standard protocol interfaces such as SPI are also automatically generated in LE logic by the Quartus II software.

 For more information about the UFM interface signals and the Quartus II LE-based alternate interfaces, refer to the *User Flash Memory in MAX V Devices* chapter.

## UFM Block to Logic Array Interface

The UFM block is a small partition of the flash memory that contains the CFM block, as shown in [Figure 2-1](#) and [Figure 2-2](#). The UFM block for the 5M40Z, 5M80Z, 5M160Z, and 5M240Z devices is located on the left side of the device adjacent to the left most LAB column. The UFM blocks for the 5M570Z, 5M1270Z, and 5M2210Z devices are located at the bottom left of the device. The UFM input and output signals interface to all types of interconnects (R4 interconnect, C4 interconnect, and DirectLink interconnect to/from adjacent LAB rows). The UFM signals can also be driven from global clocks,  $GCLK[3..0]$ . The interface regions for the 5M40Z, 5M80Z, 5M160Z, and 5M240Z devices are shown in [Figure 2-16](#). The interface regions for 5M570Z, 5M1270Z, and 5M2210Z devices are shown in [Figure 2-17](#).

**Figure 2-16. 5M40Z, 5M80Z, 5M160Z, and 5M240Z UFM Block LAB Row Interface** *(Note 1), (2)*

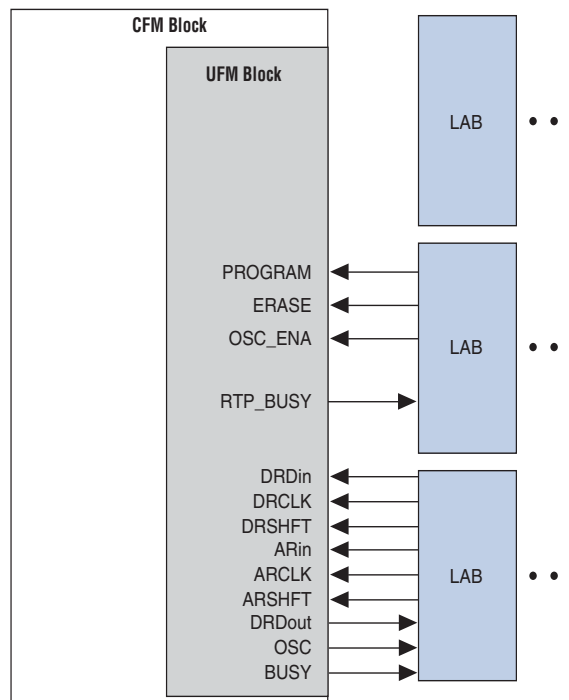

**Notes to Figure 2-16:**

- (1) The UFM block inputs and outputs can drive to and from all types of interconnects, not only DirectLink interconnects from adjacent row LABs.
- (2) Not applicable to the T144 package of the 5M240Z device.

**Figure 2-17. 5M240Z, 5M570Z, 5M1270Z, and 5M2210Z UFM Block LAB Row Interface (Note 1)**

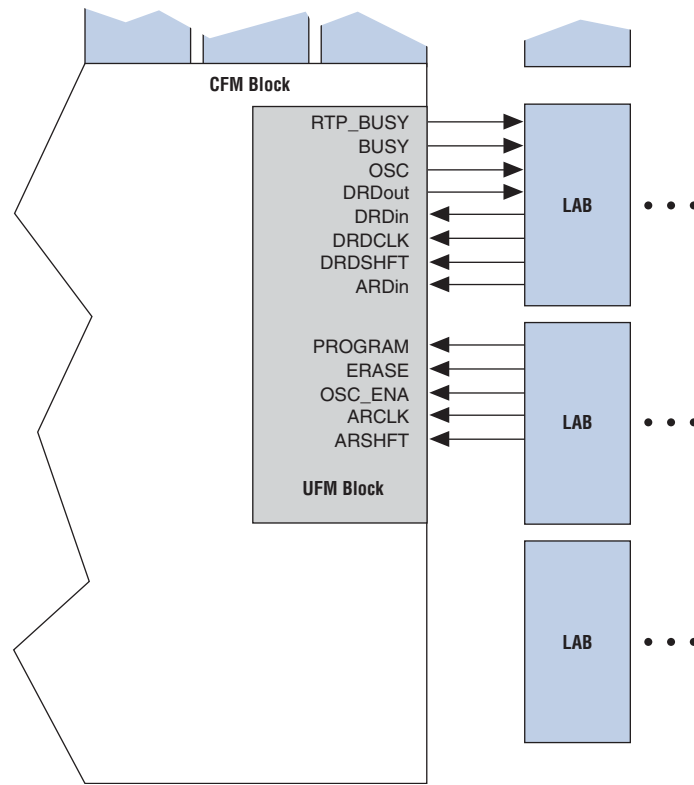

**Note to Figure 2-17:**

(1) Only applicable to the T144 package of the 5M240Z device.

## Core Voltage

The MAX V architecture supports a 1.8-V core voltage on the  $V_{CCINT}$  supply. You must use a 1.8-V  $V_{CC}$  external supply to power the  $V_{CCINT}$  pins.

**Figure 2-18. Core Voltage Feature in MAX V Devices**

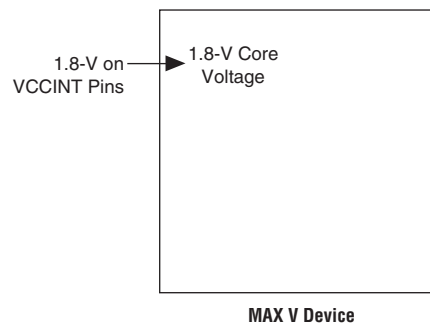

## I/O Structure

IOEs support many features, including:

- LVTTTL, LVCMOS, LVDS, and RSDS I/O standards
- 3.3-V, 32-bit, 33-MHz PCI compliance
- JTAG boundary-scan test (BST) support
- Programmable drive strength control
- Weak pull-up resistors during power-up and in system programming
- Slew-rate control
- Tri-state buffers with individual output enable control
- Bus-hold circuitry
- Programmable pull-up resistors in user mode
- Unique output enable per pin
- Open-drain outputs
- Schmitt trigger inputs
- Fast I/O connection
- Programmable input delay

MAX V device IOEs contain a bidirectional I/O buffer. [Figure 2-19](#) shows the MAX V IOE structure. Registers from adjacent LABs can drive to or be driven from the IOE's bidirectional I/O buffers. The Quartus II software automatically attempts to place registers in the adjacent LAB with fast I/O connection to achieve the fastest possible clock-to-output and registered output enable timing. When the fast input registers option is enabled, the Quartus II software automatically routes the register to guarantee zero hold time. You can set timing assignments in the Quartus II software to achieve desired I/O timing.

## Fast I/O Connection

A dedicated fast I/O connection from the adjacent LAB to the IOEs within an I/O block provides faster output delays for clock-to-output and  $t_{PD}$  propagation delays. This connection exists for data output signals, not output enable signals or input signals. Figure 2-20, Figure 2-21, and Figure 2-22 illustrate the fast I/O connection.

Figure 2-19. IOE Structure for MAX V Devices

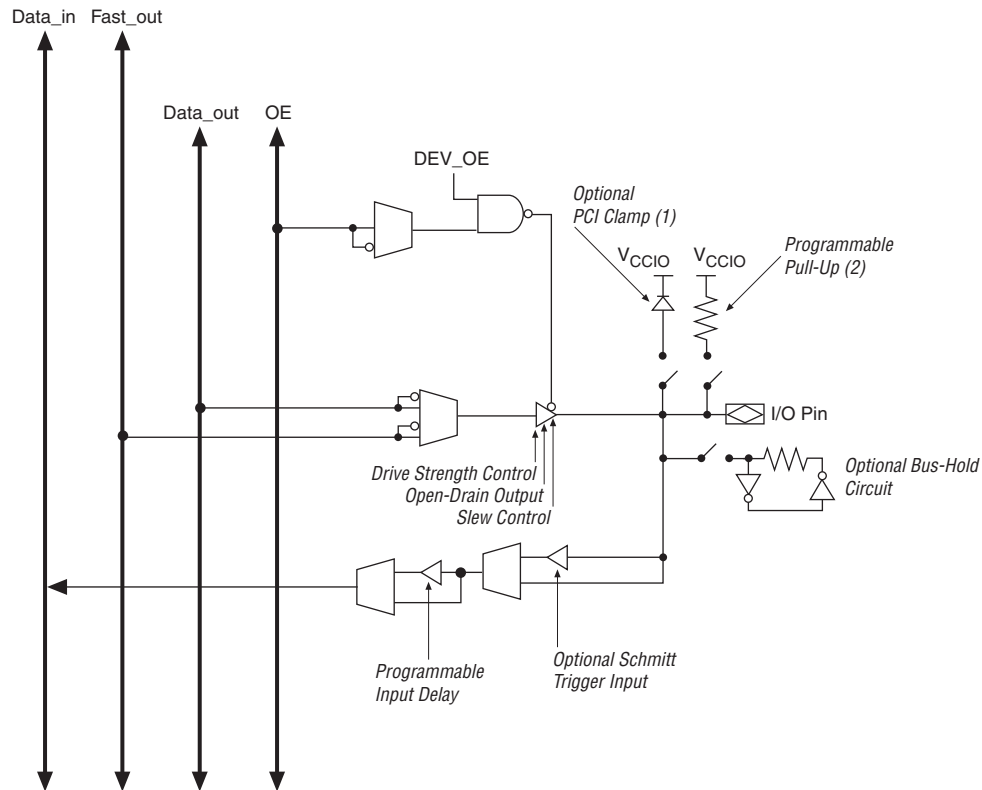

**Notes to Figure 2-19:**

- (1) Available only in I/O bank 3 of 5M1270Z and 5M2210Z devices.
- (2) The programmable pull-up resistor is active during power-up, in-system programming (ISP), and if the device is unprogrammed.

## I/O Blocks

The IOEs are located in I/O blocks around the periphery of the MAX V device. There are up to seven IOEs per row I/O block and up to four IOEs per column I/O block. Each column or row I/O block interfaces with its adjacent LAB and MultiTrack interconnect to distribute signals throughout the device. The row I/O blocks drive row, column, or DirectLink interconnects. The column I/O blocks drive column interconnects.

 5M40Z, 5M80Z, 5M160Z, and 5M240Z devices have a maximum of five IOEs per row I/O block.

Figure 2-20 shows how a row I/O block connects to the logic array.

**Figure 2-20. Row I/O Block Connection to the Interconnect (Note 1)**

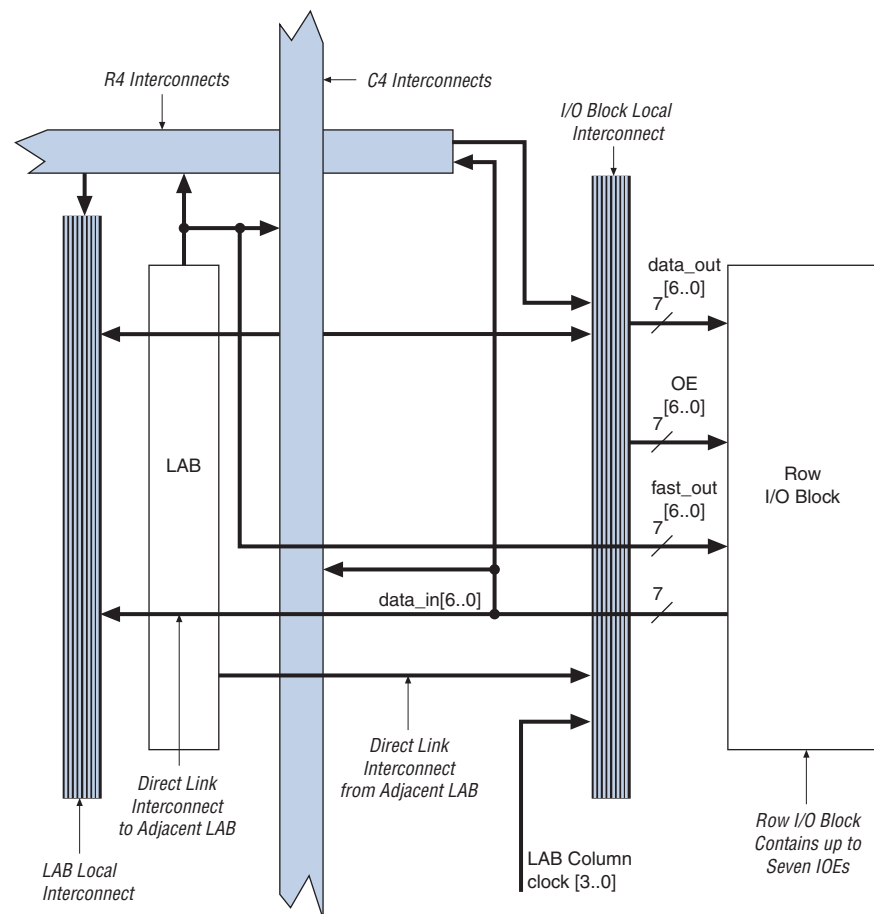

**Note to Figure 2-20:**

- (1) Each of the seven IOEs in the row I/O block can have one `data_out` or `fast_out` output, one `OE` output, and one `data_in` input.

Figure 2-21 shows how a column I/O block connects to the logic array.

**Figure 2-21. Column I/O Block Connection to the Interconnect (Note 1)**

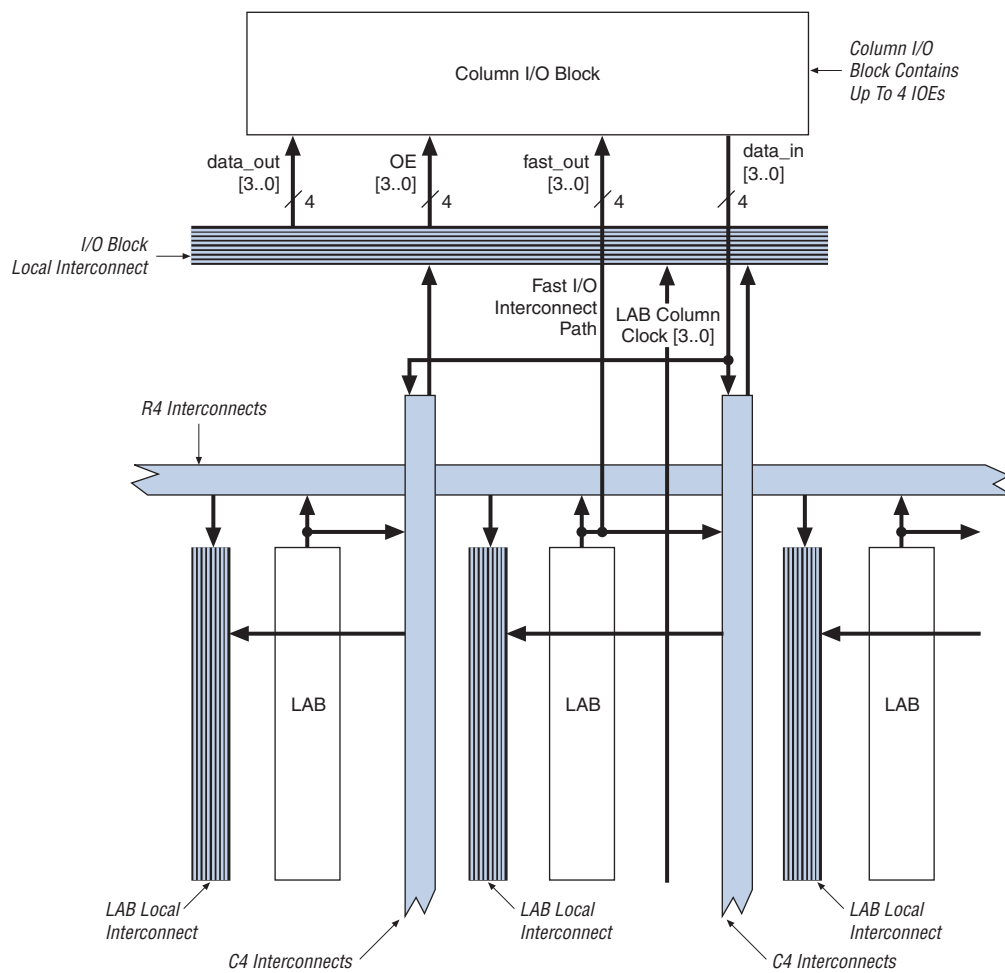

**Note to Figure 2-21:**

- (1) Each of the four IOEs in the column I/O block can have one `data_out` or `fast_out` output, one `OE` output, and one `data_in` input.

## I/O Standards and Banks

Table 2-4 lists the I/O standards supported by MAX V devices.

**Table 2-4. MAX V I/O Standards (Part 1 of 2)**

I/O Standard	Type	Output Supply Voltage ( $V_{CCIO}$ ) (V)
3.3-V LVTTTL/LVCMOS	Single-ended	3.3
2.5-V LVTTTL/LVCMOS	Single-ended	2.5
1.8-V LVTTTL/LVCMOS	Single-ended	1.8
1.5-V LVCMOS	Single-ended	1.5
1.2-V LVCMOS	Single-ended	1.2

**Table 2-4. MAX V I/O Standards (Part 2 of 2)**

I/O Standard	Type	Output Supply Voltage ( $V_{CCIO}$ ) (V)
3.3-V PCI (1)	Single-ended	3.3
LVDS (2)	Differential	2.5
RSDS (3)	Differential	2.5

**Notes to Table 2-4:**

- (1) The 3.3-V PCI compliant I/O is supported in Bank 3 of the 5M1270Z and 5M2210Z devices.
- (2) MAX V devices only support emulated LVDS output using a three resistor network (LVDS\_E\_3R).
- (3) MAX V devices only support emulated RSDS output using a three resistor network (RSDS\_E\_3R).

The 5M40Z, 5M80Z, 5M160Z, 5M240Z, and 5M570Z devices support two I/O banks, as shown in Figure 2-22. Each of these banks support all the LVTTTL, LVCMOS, LVDS, and RSDS standards shown in Table 2-4. PCI compliant I/O is not supported in these devices and banks.

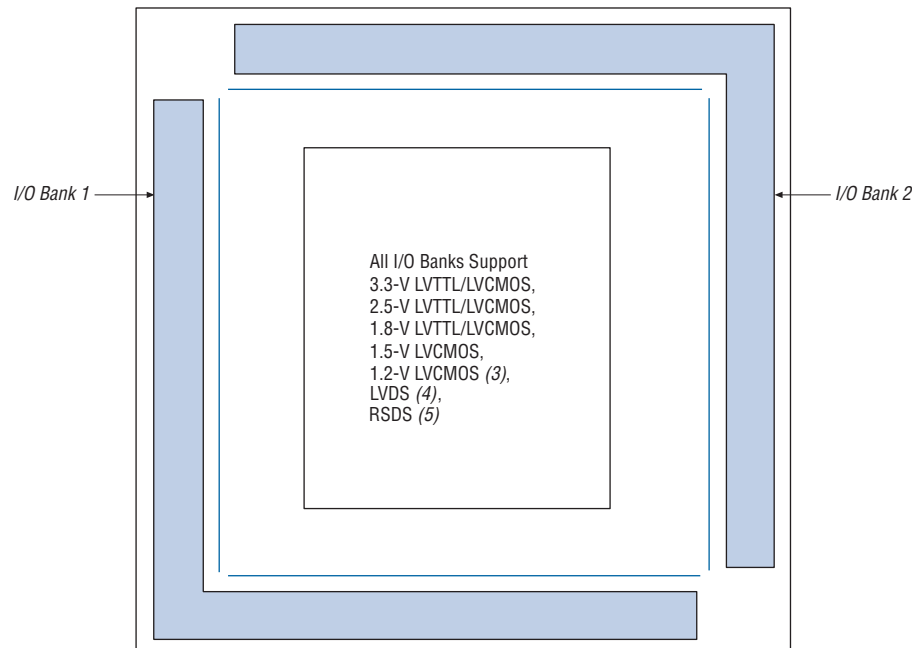
**Figure 2-22. I/O Banks for 5M40Z, 5M80Z, 5M160Z, 5M240Z, and 5M570Z Devices (Note 1), (2)****Notes to Figure 2-22:**

- (1) Figure 2-22 is a top view of the silicon die.
- (2) Figure 2-22 is a graphical representation only. Refer to the pin list and the Quartus II software for exact pin locations.
- (3) This I/O standard is not supported in Bank 1.
- (4) Emulated LVDS output using a three resistor network (LVDS\_E\_3R).
- (5) Emulated RSDS output using a three resistor network (RSDS\_E\_3R).

The 5M1270Z and 5M2210Z devices support four I/O banks, as shown in Figure 2–23. Each of these banks support all of the LVTTTL, LVCMOS, LVDS, and RSDS standards shown in Table 2–4. PCI compliant I/O is supported in Bank 3. Bank 3 supports the PCI clamping diode on inputs and PCI drive compliance on outputs. You must use Bank 3 for designs requiring PCI compliant I/O pins. The Quartus II software automatically places I/O pins in this bank if assigned with the PCI I/O standard.

**Figure 2–23. I/O Banks for 5M1270Z and 5M2210Z Devices (Note 1), (2)**

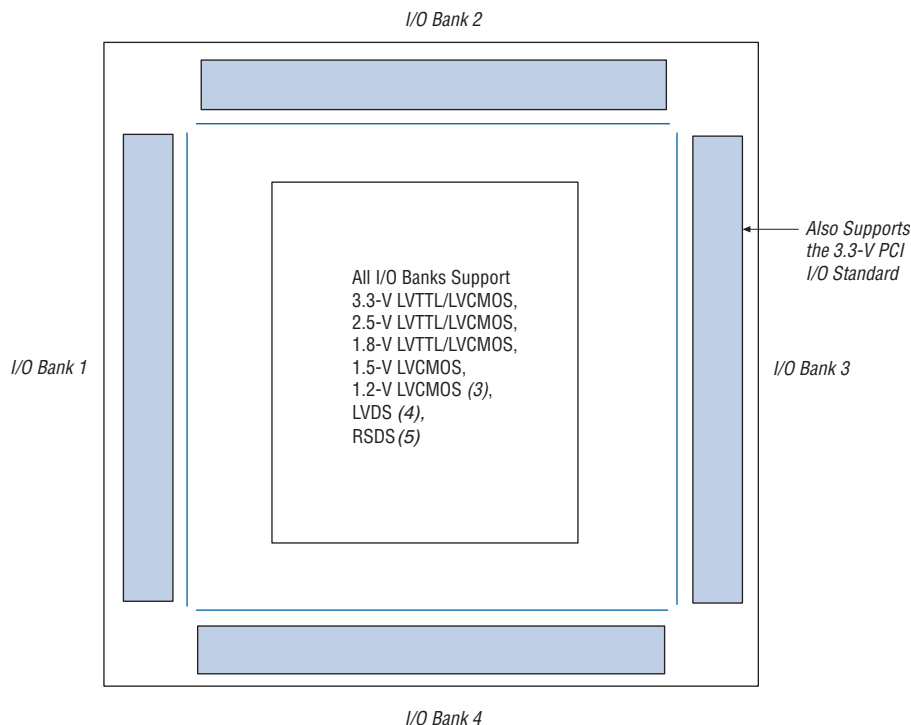

**Notes to Figure 2–23:**

- (1) Figure 2–23 is a top view of the silicon die.
- (2) Figure 2–23 is a graphical representation only. Refer to the pin list and the Quartus II software for exact pin locations.
- (3) This I/O standard is not supported in Bank 1.
- (4) Emulated LVDS output using a three resistor network (LVDS\_E\_3R).
- (5) Emulated RSDS output using a three resistor network (RSDS\_E\_3R).

Each I/O bank has dedicated  $V_{CCIO}$  pins that determine the voltage standard support in that bank. A single device can support 1.2-V, 1.5-V, 1.8-V, 2.5-V, and 3.3-V interfaces; each individual bank can support a different standard. Each I/O bank can support multiple standards with the same  $V_{CCIO}$  for input and output pins. For example, when  $V_{CCIO}$  is 3.3 V, Bank 3 can support LVTTTL, LVCMOS, and 3.3-V PCI.  $V_{CCIO}$  powers both the input and output buffers in MAX V devices.

The JTAG pins for MAX V devices are dedicated pins that cannot be used as regular I/O pins. The pins TMS, TDI, TDO, and TCK support all the I/O standards shown in Table 2–4 on page 2–29 except for PCI and 1.2-V LVCMOS. These pins reside in Bank 1 for all MAX V devices and their I/O standard support is controlled by the  $V_{CCIO}$  setting for Bank 1.

## PCI Compliance

The MAX V 5M1270Z and 5M2210Z devices are compliant with PCI applications as well as all 3.3-V electrical specifications in the *PCI Local Bus Specification Revision 2.2*. These devices are also large enough to support PCI intellectual property (IP) cores. Table 2-5 shows the MAX V device speed grades that meet the PCI timing specifications.

**Table 2-5. 3.3-V PCI Electrical Specifications and PCI Timing Support for MAX V Devices**

Device	33-MHz PCI
5M1270Z	All Speed Grades
5M2210Z	All Speed Grades

## LVDS and RSDS Channels

The MAX V device supports emulated LVDS and RSDS outputs on both row and column I/O banks. You can configure the rows and columns as emulated LVDS or RSDS output buffers that use two single-ended output buffers with three external resistor networks.

**Table 2-6. LVDS and RSDS Channels supported in MAX V Devices (Note 1)**

Device	64 MBGA	64 EQFP	68 MBGA	100 TQFP	100 MBGA	144 TQFP	256 FBGA	324 FBGA
5M40Z	10 eTx	20 eTx	—	—	—	—	—	—
5M80Z	10 eTx	20 eTx	20 eTx	33 eTx	—	—	—	—
5M160Z	—	20 eTx	20 eTx	33 eTx	33 eTx	—	—	—
5M240Z	—	—	20 eTx	33 eTx	33 eTx	49 eTx	—	—
5M570Z	—	—	—	28 eTx	28 eTx	49 eTx	75 eTx	—
5M1270Z	—	—	—	—	—	42 eTx	90 eTx	115 eTx
5M2210Z	—	—	—	—	—	—	83 eTx	115 eTx

**Note to Table 2-6:**

(1) eTx = emulated LVDS output buffers (LVDS\_E\_3R) or emulated RSDS output buffers (RSDS\_E\_3R).

## Schmitt Trigger

The input buffer for each MAX V device I/O pin has an optional Schmitt trigger setting for the 3.3-V and 2.5-V standards. The Schmitt trigger allows input buffers to respond to slow input edge rates with a fast output edge rate. Most importantly, Schmitt triggers provide hysteresis on the input buffer, preventing slow-rising noisy input signals from ringing or oscillating on the input signal driven into the logic array. This provides system noise tolerance on MAX V inputs, but adds a small, nominal input delay.

The JTAG input pins (TMS, TCK, and TDI) have Schmitt trigger buffers that are always enabled.



The TCK input is susceptible to high pulse glitches when the input signal fall time is greater than 200 ns for all I/O standards.

## Output Enable Signals

Each MAX V IOE output buffer supports output enable signals for tri-state control. The output enable signal can originate from the GCLK[3..0] global signals or from the MultiTrack interconnect. The MultiTrack interconnect routes output enable signals and allows for a unique output enable for each output or bidirectional pin.

MAX V devices also provide a chip-wide output enable pin (DEV\_OE) to control the output enable for every output pin in the design. An option set before compilation in the Quartus II software controls this pin. This chip-wide output enable uses its own routing resources and does not use any of the four global resources. If this option is turned on, all outputs on the chip operate normally when DEV\_OE is asserted. When the pin is deasserted, all outputs are tri-stated. If this option is turned off, the DEV\_OE pin is disabled when the device operates in user mode and is available as a user I/O pin.

## Programmable Drive Strength

The output buffer for each MAX V device I/O pin has two levels of programmable drive strength control for each of the LVTTTL and LVCMOS I/O standards. Programmable drive strength provides system noise reduction control for high performance I/O designs. Although a separate slew-rate control feature exists, using the lower drive strength setting provides signal slew-rate control to reduce system noise and signal overshoot without the large delay adder associated with the slew-rate control feature. Table 2-7 lists the possible settings for the I/O standards with drive strength control. The Quartus II software uses the maximum current strength as the default setting. The PCI I/O standard is always set at 20 mA with no alternate setting.

**Table 2-7. Programmable Drive Strength (Note 1)**

I/O Standard	IOH/IOL Current Strength Setting (mA)
3.3-V LVTTTL	16
	8
3.3-V LVCMOS	8
	4
2.5-V LVTTTL/LVCMOS	14
	7
1.8-V LVTTTL/LVCMOS	6
	3
1.5-V LVCMOS	4
	2
1.2-V LVCMOS	3

**Note to Table 2-7:**

- (1) The IOH current strength numbers shown are for a condition of a  $V_{OUT} = V_{OH}$  minimum, where the  $V_{OH}$  minimum is specified by the I/O standard. The IOL current strength numbers shown are for a condition of a  $V_{OUT} = V_{OL}$  maximum, where the  $V_{OL}$  maximum is specified by the I/O standard. For 2.5-V LVTTTL/LVCMOS, the IOH condition is  $V_{OUT} = 1.7$  V and the IOL condition is  $V_{OUT} = 0.7$  V.



The programmable drive strength feature can be used simultaneously with the slew-rate control feature.

## Slew-Rate Control

The output buffer for each MAX V device I/O pin has a programmable output slew-rate control that can be configured for low noise or high-speed performance. A faster slew rate provides high-speed transitions for high-performance systems. However, these fast transitions may introduce noise transients into the system. A slow slew rate reduces system noise, but adds a nominal output delay to rising and falling edges. The lower the voltage standard (for example, 1.8-V LVTTTL) the larger the output delay when slow slew is enabled. Each I/O pin has an individual slew-rate control, allowing you to specify the slew rate on a pin-by-pin basis. The slew-rate control affects both the rising and falling edges. If no slew-rate control is specified, the Quartus II software defaults to a fast slew rate.



The slew-rate control feature can be used simultaneously with the programmable drive strength feature.

## Open-Drain Output

MAX V devices provide an optional open-drain (equivalent to open-collector) output for each I/O pin. This open-drain output enables the device to provide system-level control signals (for example, interrupt and write enable signals) that can be asserted by any of several devices. This output can also provide an additional wired-OR plane.

## Programmable Ground Pins

Each unused I/O pin on MAX V devices can be used as an additional ground pin. This programmable ground feature does not require the use of the associated LEs in the device. In the Quartus II software, unused pins can be set as programmable GND on a global default basis or they can be individually assigned. Unused pins also have the option of being set as tri-stated input pins.

## Bus-Hold



Each MAX V device I/O pin provides an optional bus-hold feature. The bus-hold circuitry can hold the signal on an I/O pin at its last-driven state. Because the bus-hold feature holds the last-driven state of the pin until the next input signal is present, an external pull-up or pull-down resistor is not necessary to hold a signal level when the bus is tri-stated.

The bus-hold circuitry also pulls un-driven pins away from the input threshold voltage where noise can cause unintended high-frequency switching. You can select this feature individually for each I/O pin. The bus-hold output will drive no higher than  $V_{CCIO}$  to prevent overdriving signals. If the bus-hold feature is enabled, the device cannot use the programmable pull-up option.

The bus-hold circuitry is only active after the device has fully initialized. The bus-hold circuit captures the value on the pin present at the moment user mode is entered.

## Programmable Pull-Up Resistor

Each MAX V device I/O pin provides an optional programmable pull-up resistor during user mode. If you enable this feature for an I/O pin, the pull-up resistor holds the output to the  $V_{CCIO}$  level of the output pin's bank.

-  The programmable pull-up resistor feature should not be used at the same time as the bus-hold feature on a given I/O pin.
-  The programmable pull-up resistor is active during power-up, ISP, and if the device is unprogrammed.

## Programmable Input Delay

The MAX V IOE includes a programmable input delay that is activated to ensure zero hold times. A path where a pin directly drives a register, with minimal routing between the two, may require the delay to ensure zero hold time. However, a path where a pin drives a register through long routing or through combinational logic may not require the delay to achieve a zero hold time. The Quartus II software uses this delay to ensure zero hold times when needed.

## MultiVolt I/O Interface

The MAX V architecture supports the MultiVolt I/O interface feature, which allows MAX V devices in all packages to interface with systems of different supply voltages. The devices have one set of VCC pins for internal operation ( $V_{CCINT}$ ), and up to four sets for input buffers and I/O output driver buffers ( $V_{CCIO}$ ), depending on the number of I/O banks available in the devices where each set of  $V_{CCIO}$  pins powers one I/O bank. The 5M40Z, 5M80Z, 5M160Z, 5M240Z, and 5M570Z devices each have two I/O banks while the 5M1270Z and 5M2210Z devices each have four I/O banks.

Connect  $V_{CCIO}$  pins to either a 1.2-, 1.5-, 1.8-, 2.5-, or 3.3-V power supply, depending on the output requirements. The output levels are compatible with systems of the same voltage as the power supply (that is, when  $V_{CCIO}$  pins are connected to a 1.5-V power supply, the output levels are compatible with 1.5-V systems). When  $V_{CCIO}$  pins are connected to a 3.3-V power supply, the output high is 3.3 V and is compatible with 3.3-V or 5.0-V systems. Table 2-8 summarizes MAX V MultiVolt I/O support.

**Table 2-8. MultiVolt I/O Support in MAX V Devices (Part 1 of 2) (Note 1)**

VCCIO (V)	Input Signal						Output Signal					
	1.2 V	1.5 V	1.8 V	2.5 V	3.3 V	5.0 V	1.2 V	1.5 V	1.8 V	2.5 V	3.3 V	5.0 V
1.2	✓	—	—	—	—	—	✓	—	—	—	—	—
1.5	—	✓	✓	✓	✓	—	✓	✓	—	—	—	—
1.8	—	✓	✓	✓	✓	—	✓ (2)	✓ (2)	✓	—	—	—
2.5	—	—	—	✓	✓	—	✓ (3)	✓ (3)	✓ (3)	✓	—	—

**Table 2-8. MultiVolt I/O Support in MAX V Devices (Part 2 of 2) (Note 1)**

VCCIO (V)	Input Signal						Output Signal					
	1.2 V	1.5 V	1.8 V	2.5 V	3.3 V	5.0 V	1.2 V	1.5 V	1.8 V	2.5 V	3.3 V	5.0 V
3.3	—	—	—	✓ (4)	✓	✓ (5)	✓ (6)	✓ (6)	✓ (6)	✓ (6)	✓	✓ (7)

**Notes to Table 2-8:**

- (1) To drive inputs higher than  $V_{CCIO}$  but less than 4.0 V including the overshoot, disable the I/O clamp diode. However, to drive 5.0-V signals to the device, enable the I/O clamp diode to prevent  $V_I$  from rising above 4.0 V. Use an external diode if the I/O pin does not support the clamp diode.
- (2) When  $V_{CCIO} = 1.8$  V, a MAX V device can drive a 1.2-V or 1.5-V device with 1.8-V tolerant inputs.
- (3) When  $V_{CCIO} = 2.5$  V, a MAX V device can drive a 1.2-V, 1.5-V, or 1.8-V device with 2.5-V tolerant inputs.
- (4) When  $V_{CCIO} = 3.3$  V and a 2.5-V input signal feeds an input pin, the VCCIO supply current will be slightly larger than expected.
- (5) MAX V devices can be 5.0-V tolerant with the use of an external resistor and the internal I/O clamp diode on the 5M1270Z and 5M2210Z devices. Use an external clamp diode if the internal clamp diode is not available.
- (6) When  $V_{CCIO} = 3.3$  V, a MAX V device can drive a 1.2-V, 1.5-V, 1.8-V, or 2.5-V device with 3.3-V tolerant inputs.
- (7) When  $V_{CCIO} = 3.3$  V, a MAX V device can drive a device with 5.0-V TTL inputs but not 5.0-V CMOS inputs. For 5.0-V CMOS, open-drain setting with internal I/O clamp diode (available only on 5M1270Z and 5M2210Z devices) and external resistor is required. Use an external clamp diode if the internal clamp diode is not available.

## Document Revision History

Table 2-9 lists the revision history for this chapter.

**Table 2-9. Document Revision History**

Date	Version	Changes
December 2010	1.0	Initial release.

This chapter covers the electrical and switching characteristics for MAX<sup>®</sup> V devices. Electrical characteristics include operating conditions and power consumptions. This chapter also describes the timing model and specifications.

You must consider the recommended DC and switching conditions described in this chapter to maintain the highest possible performance and reliability of the MAX V devices.

This chapter contains the following sections:

- “Operating Conditions” on page 3–1
- “Power Consumption” on page 3–10
- “Timing Model and Specifications” on page 3–10

## Operating Conditions

Table 3–1 through Table 3–15 on page 3–9 list information about absolute maximum ratings, recommended operating conditions, DC electrical characteristics, and other specifications for MAX V devices.

### Absolute Maximum Ratings

Table 3–1 lists the absolute maximum ratings for the MAX V device family.

**Table 3–1. Absolute Maximum Ratings for MAX V Devices (Note 1), (2)**

Symbol	Parameter	Conditions	Minimum	Maximum	Unit
V <sub>CCINT</sub>	Internal supply voltage	With respect to ground	–0.5	2.4	V
V <sub>CCIO</sub>	I/O supply voltage	—	–0.5	4.6	V
V <sub>I</sub>	DC input voltage	—	–0.5	4.6	V
I <sub>OUT</sub>	DC output current, per pin	—	–25	25	mA
T <sub>STG</sub>	Storage temperature	No bias	–65	150	°C
T <sub>AMB</sub>	Ambient temperature	Under bias (3)	–65	135	°C
T <sub>J</sub>	Junction temperature	TQFP and BGA packages under bias	—	135	°C

**Notes to Table 3–1:**

- (1) For more information, refer to the *Operating Requirements for Altera Devices Data Sheet*.
- (2) Conditions beyond those listed in Table 3–1 may cause permanent damage to a device. Additionally, device operation at the absolute maximum ratings for extended periods of time may have adverse affects on the device.
- (3) For more information about “under bias” conditions, refer to Table 3–2.

© 2011 Altera Corporation. All rights reserved. ALTERA, ARRIA, CYCLONE, HARDCOPY, MAX, MEGACORE, NIOS, QUARTUS and STRATIX are Reg. U.S. Pat. & Tm. Off. and/or trademarks of Altera Corporation in the U.S. and other countries. All other trademarks and service marks are the property of their respective holders as described at [www.altera.com/common/legal.html](http://www.altera.com/common/legal.html). Altera warrants performance of its semiconductor products to current specifications in accordance with Altera’s standard warranty, but reserves the right to make changes to any products and services at any time without notice. Altera assumes no responsibility or liability arising out of the application or use of any information, product, or service described herein except as expressly agreed to in writing by Altera. Altera customers are advised to obtain the latest version of device specifications before relying on any published information and before placing orders for products or services.

## Recommended Operating Conditions

Table 3-2 lists recommended operating conditions for the MAX V device family.

**Table 3-2. Recommended Operating Conditions for MAX V Devices**

Symbol	Parameter	Conditions	Minimum	Maximum	Unit
$V_{CCINT}$ (1)	1.8-V supply voltage for internal logic and in-system programming (ISP)	MAX V devices	1.71	1.89	V
$V_{CCIO}$ (1)	Supply voltage for I/O buffers, 3.3-V operation	—	3.00	3.60	V
	Supply voltage for I/O buffers, 2.5-V operation	—	2.375	2.625	V
	Supply voltage for I/O buffers, 1.8-V operation	—	1.71	1.89	V
	Supply voltage for I/O buffers, 1.5-V operation	—	1.425	1.575	V
	Supply voltage for I/O buffers, 1.2-V operation	—	1.14	1.26	V
$V_I$	Input voltage	(2), (3), (4)	-0.5	4.0	V
$V_O$	Output voltage	—	0	$V_{CCIO}$	V
$T_J$	Operating junction temperature	Commercial range	0	85	°C
		Industrial range	-40	100	°C
		Extended range (5)	-40	125	°C

**Notes to Table 3-2:**

- (1) MAX V device ISP and/or user flash memory (UFM) programming using JTAG or logic array is not guaranteed outside the recommended operating conditions (for example, if brown-out occurs in the system during a potential write/program sequence to the UFM, Altera recommends that you read back the UFM contents and verify it against the intended write data).
- (2) The minimum DC input is -0.5 V. During transitions, the inputs may undershoot to -2.0 V for input currents less than 100 mA and periods shorter than 20 ns.
- (3) During transitions, the inputs may overshoot to the voltages shown below based on the input duty cycle. The DC case is equivalent to 100% duty cycle. For more information about 5.0-V tolerance, refer to the *Using MAX V Devices in Multi-Voltage Systems* chapter.
 

$V_{IN}$	Max. Duty Cycle
4.0 V	100% (DC)
4.1 V	90%
4.2 V	50%
4.3 V	30%
4.4 V	17%
4.5 V	10%
- (4) All pins, including the clock, I/O, and JTAG pins, may be driven before  $V_{CCINT}$  and  $V_{CCIO}$  are powered.
- (5) For the extended temperature range of 100 to 125°C, MAX V UFM programming (erase/write) is only supported using the JTAG interface. UFM programming using the logic array interface is not guaranteed in this range.

## Programming/Erase Specifications

Table 3–3 lists the programming/erase specifications for the MAX V device family.

**Table 3–3. Programming/Erase Specifications for MAX V Devices**

Parameter	Block	Minimum	Typical	Maximum	Unit
Erase and reprogram cycles	UFM	—	—	1000 (1)	Cycles
	Configuration flash memory (CFM)	—	—	100	Cycles

Note to Table 3–3:

(1) This value applies to the commercial grade devices. For the industrial grade devices, the value is 100 cycles.

## DC Electrical Characteristics

Table 3–4 lists DC electrical characteristics for the MAX V device family.

**Table 3–4. DC Electrical Characteristics for MAX V Devices (Note 1) (Part 1 of 2)**

Symbol	Parameter	Conditions	Minimum	Typical	Maximum	Unit
$I_I$	Input pin leakage current	$V_I = V_{CCIO}$ max to 0 V (2)	–10	—	10	$\mu$ A
$I_{OZ}$	Tri-stated I/O pin leakage current	$V_O = V_{CCIO}$ max to 0 V (2)	–10	—	10	$\mu$ A
$I_{CCSTANDBY}$	$V_{CCINT}$ supply current (standby) (3)	5M40Z, 5M80Z, 5M160Z, and 5M240Z (Commercial grade) (4), (5)	—	25	90	$\mu$ A
		5M240Z (Commercial grade) (6)	—	27	96	$\mu$ A
		5M40Z, 5M80Z, 5M160Z, and 5M240Z (Industrial grade) (5), (7)	—	25	139	$\mu$ A
		5M240Z (Industrial grade) (6)	—	27	152	$\mu$ A
		5M570Z (Commercial grade) (4)	—	27	96	$\mu$ A
		5M570Z (Industrial grade) (7)	—	27	152	$\mu$ A
		5M1270Z and 5M2210Z	—	2	—	mA
$V_{SCHMITT}$ (8)	Hysteresis for Schmitt trigger input (9)	$V_{CCIO} = 3.3$ V	—	400	—	mV
		$V_{CCIO} = 2.5$ V	—	190	—	mV
$I_{CCPOWERUP}$	$V_{CCINT}$ supply current during power-up (10)	MAX V devices	—	—	40	mA
$R_{PULLUP}$	Value of I/O pin pull-up resistor during user mode and ISP	$V_{CCIO} = 3.3$ V (11)	5	—	25	k $\Omega$
		$V_{CCIO} = 2.5$ V (11)	10	—	40	k $\Omega$
		$V_{CCIO} = 1.8$ V (11)	25	—	60	k $\Omega$
		$V_{CCIO} = 1.5$ V (11)	45	—	95	k $\Omega$
		$V_{CCIO} = 1.2$ V (11)	80	—	130	k $\Omega$

**Table 3-4. DC Electrical Characteristics for MAX V Devices (Note 1) (Part 2 of 2)**

Symbol	Parameter	Conditions	Minimum	Typical	Maximum	Unit
$I_{PULLUP}$	I/O pin pull-up resistor current when I/O is unprogrammed	—	—	—	300	$\mu$ A
$C_{IO}$	Input capacitance for user I/O pin	—	—	—	8	pF
$C_{GCLK}$	Input capacitance for dual-purpose GCLK/user I/O pin	—	—	—	8	pF

**Notes to Table 3-4:**

- (1) Typical values are for  $T_A = 25^\circ\text{C}$ ,  $V_{CCINT} = 1.8\text{ V}$  and  $V_{CCIO} = 1.2, 1.5, 1.8, 2.5, \text{ or } 3.3\text{ V}$ .
- (2) This value is specified for normal device operation. The value may vary during power-up. This applies to all  $V_{CCIO}$  settings (3.3, 2.5, 1.8, 1.5, and 1.2 V).
- (3)  $V_I = \text{ground}$ , no load, and no toggling inputs.
- (4) Commercial temperature ranges from  $0^\circ\text{C}$  to  $85^\circ\text{C}$  with the maximum current at  $85^\circ\text{C}$ .
- (5) Not applicable to the T144 package of the 5M240Z device.
- (6) Only applicable to the T144 package of the 5M240Z device.
- (7) Industrial temperature ranges from  $-40^\circ\text{C}$  to  $100^\circ\text{C}$  with the maximum current at  $100^\circ\text{C}$ .
- (8) This value applies to commercial and industrial range devices. For extended temperature range devices, the  $V_{SCHMITT}$  typical value is 300 mV for  $V_{CCIO} = 3.3\text{ V}$  and 120 mV for  $V_{CCIO} = 2.5\text{ V}$ .
- (9) The  $\overline{\text{TCK}}$  input is susceptible to high pulse glitches when the input signal fall time is greater than 200 ns for all I/O standards.
- (10) This is a peak current value with a maximum duration of  $t_{CONFIG}$  time.
- (11) Pin pull-up resistance values will lower if an external source drives the pin higher than  $V_{CCIO}$ .

## Output Drive Characteristics

Figure 3-1 shows the typical drive strength characteristics of MAX V devices.

**Figure 3-1. Output Drive Characteristics of MAX V Devices (Note 1)**

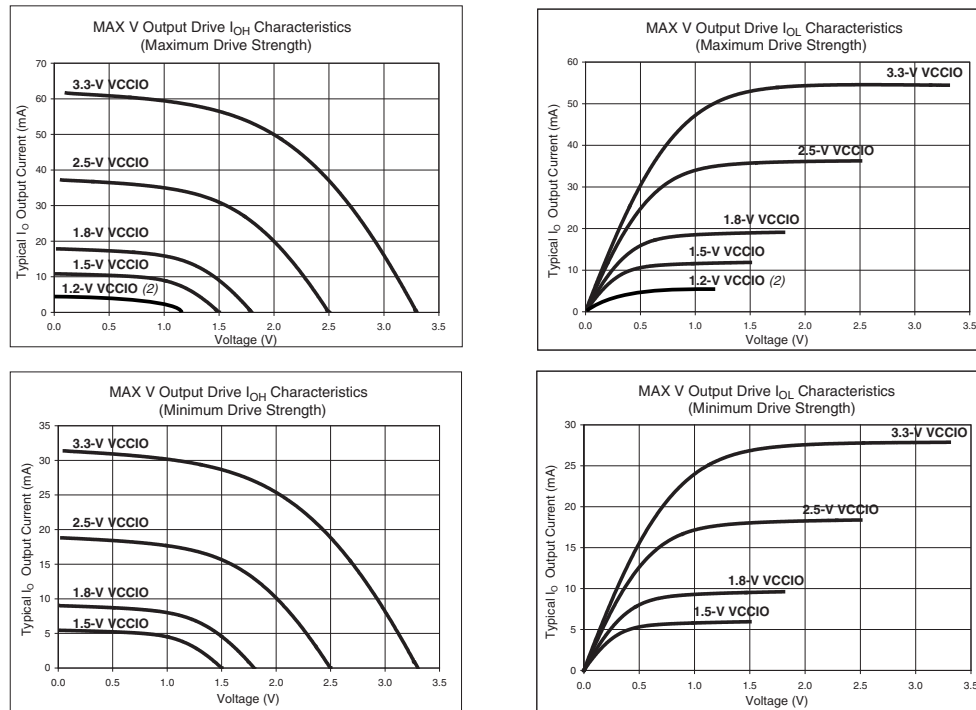

**Notes to Figure 3-1:**

- (1) The DC output current per pin is subject to the absolute maximum rating of Table 3-1 on page 3-1.
- (2) 1.2-V  $V_{CCIO}$  is only applicable to the maximum drive strength.

## I/O Standard Specifications

Table 3-5 through Table 3-13 on page 3-8 list the I/O standard specifications for the MAX V device family.

**Table 3-5. 3.3-V LVTTTL Specifications for MAX V Devices**

Symbol	Parameter	Conditions	Minimum	Maximum	Unit
$V_{CCIO}$	I/O supply voltage	—	3.0	3.6	V
$V_{IH}$	High-level input voltage	—	1.7	4.0	V
$V_{IL}$	Low-level input voltage	—	-0.5	0.8	V
$V_{OH}$	High-level output voltage	$I_{OH} = -4$ mA (1)	2.4	—	V
$V_{OL}$	Low-level output voltage	$I_{OL} = 4$ mA (1)	—	0.45	V

**Note to Table 3-5:**

- (1) This specification is supported across all the programmable drive strength settings available for this I/O standard, as shown in the *MAX V Device Architecture* chapter.

**Table 3-6. 3.3-V LVCMOS Specifications for MAX V Devices**

Symbol	Parameter	Conditions	Minimum	Maximum	Unit
$V_{CCIO}$	I/O supply voltage	—	3.0	3.6	V
$V_{IH}$	High-level input voltage	—	1.7	4.0	V
$V_{IL}$	Low-level input voltage	—	-0.5	0.8	V
$V_{OH}$	High-level output voltage	$V_{CCIO} = 3.0$ , $I_{OH} = -0.1$ mA (1)	$V_{CCIO} - 0.2$	—	V
$V_{OL}$	Low-level output voltage	$V_{CCIO} = 3.0$ , $I_{OL} = 0.1$ mA (1)	—	0.2	V

**Note to Table 3-6:**

- (1) This specification is supported across all the programmable drive strength settings available for this I/O standard, as shown in the *MAX V Device Architecture* chapter.

**Table 3-7. 2.5-V I/O Specifications for MAX V Devices**

Symbol	Parameter	Conditions	Minimum	Maximum	Unit
$V_{CCIO}$	I/O supply voltage	—	2.375	2.625	V
$V_{IH}$	High-level input voltage	—	1.7	4.0	V
$V_{IL}$	Low-level input voltage	—	-0.5	0.7	V
$V_{OH}$	High-level output voltage	$I_{OH} = -0.1$ mA (1)	2.1	—	V
		$I_{OH} = -1$ mA (1)	2.0	—	V
		$I_{OH} = -2$ mA (1)	1.7	—	V
$V_{OL}$	Low-level output voltage	$I_{OL} = 0.1$ mA (1)	—	0.2	V
		$I_{OL} = 1$ mA (1)	—	0.4	V
		$I_{OL} = 2$ mA (1)	—	0.7	V

**Note to Table 3-7:**

- (1) This specification is supported across all the programmable drive strength settings available for this I/O standard, as shown in the *MAX V Device Architecture* chapter.

**Table 3-8. 1.8-V I/O Specifications for MAX V Devices**

Symbol	Parameter	Conditions	Minimum	Maximum	Unit
$V_{CCIO}$	I/O supply voltage	—	1.71	1.89	V
$V_{IH}$	High-level input voltage	—	$0.65 \times V_{CCIO}$	2.25 (2)	V
$V_{IL}$	Low-level input voltage	—	-0.3	$0.35 \times V_{CCIO}$	V
$V_{OH}$	High-level output voltage	$I_{OH} = -2$ mA (1)	$V_{CCIO} - 0.45$	—	V
$V_{OL}$	Low-level output voltage	$I_{OL} = 2$ mA (1)	—	0.45	V

**Notes to Table 3-8:**

- (1) This specification is supported across all the programmable drive strength settings available for this I/O standard, as shown in the *MAX V Device Architecture* chapter.
- (2) This maximum  $V_{IH}$  reflects the JEDEC specification. The MAX V input buffer can tolerate a  $V_{IH}$  maximum of 4.0, as specified by the  $V_I$  parameter in Table 3-2 on page 3-2.

**Table 3–9. 1.5-V I/O Specifications for MAX V Devices**

Symbol	Parameter	Conditions	Minimum	Maximum	Unit
$V_{CCIO}$	I/O supply voltage	—	1.425	1.575	V
$V_{IH}$	High-level input voltage	—	$0.65 \times V_{CCIO}$	$V_{CCIO} + 0.3$ (2)	V
$V_{IL}$	Low-level input voltage	—	-0.3	$0.35 \times V_{CCIO}$	V
$V_{OH}$	High-level output voltage	$IOH = -2 \text{ mA}$ (1)	$0.75 \times V_{CCIO}$	—	V
$V_{OL}$	Low-level output voltage	$IOL = 2 \text{ mA}$ (1)	—	$0.25 \times V_{CCIO}$	V

**Notes to Table 3–9:**

- (1) This specification is supported across all the programmable drive strength settings available for this I/O standard, as shown in the *MAX V Device Architecture* chapter.
- (2) This maximum  $V_{IH}$  reflects the JEDEC specification. The MAX V input buffer can tolerate a  $V_{IH}$  maximum of 4.0, as specified by the  $V_I$  parameter in Table 3–2 on page 3–2.

**Table 3–10. 1.2-V I/O Specifications for MAX V Devices**

Symbol	Parameter	Conditions	Minimum	Maximum	Unit
$V_{CCIO}$	I/O supply voltage	—	1.14	1.26	V
$V_{IH}$	High-level input voltage	—	$0.8 \times V_{CCIO}$	$V_{CCIO} + 0.3$	V
$V_{IL}$	Low-level input voltage	—	-0.3	$0.25 \times V_{CCIO}$	V
$V_{OH}$	High-level output voltage	$IOH = -2 \text{ mA}$ (1)	$0.75 \times V_{CCIO}$	—	V
$V_{OL}$	Low-level output voltage	$IOL = 2 \text{ mA}$ (1)	—	$0.25 \times V_{CCIO}$	V

**Note to Table 3–10:**

- (1) This specification is supported across all the programmable drive strength settings available for this I/O standard, as shown in the *MAX V Device Architecture* chapter.

**Table 3–11. 3.3-V PCI Specifications for MAX V Devices (Note 1)**

Symbol	Parameter	Conditions	Minimum	Typical	Maximum	Unit
$V_{CCIO}$	I/O supply voltage	—	3.0	3.3	3.6	V
$V_{IH}$	High-level input voltage	—	$0.5 \times V_{CCIO}$	—	$V_{CCIO} + 0.5$	V
$V_{IL}$	Low-level input voltage	—	-0.5	—	$0.3 \times V_{CCIO}$	V
$V_{OH}$	High-level output voltage	$IOH = -500 \mu\text{A}$	$0.9 \times V_{CCIO}$	—	—	V
$V_{OL}$	Low-level output voltage	$IOL = 1.5 \text{ mA}$	—	—	$0.1 \times V_{CCIO}$	V

**Note to Table 3–11:**

- (1) 3.3-V PCI I/O standard is only supported in Bank 3 of the 5M1270Z and 5M2210Z devices.

**Table 3–12. LVDS Specifications for MAX V Devices (Note 1)**

Symbol	Parameter	Conditions	Minimum	Typical	Maximum	Unit
$V_{CCIO}$	I/O supply voltage	—	2.375	2.5	2.625	V
$V_{OD}$	Differential output voltage swing	—	247	—	600	mV
$V_{OS}$	Output offset voltage	—	1.125	1.25	1.375	V

**Note to Table 3–12:**

- (1) Supports emulated LVDS output using a three-resistor network (LVDS\_E\_3R).

**Table 3-13. RSDS Specifications for MAX V Devices (Note 1)**

Symbol	Parameter	Conditions	Minimum	Typical	Maximum	Unit
$V_{CCIO}$	I/O supply voltage	—	2.375	2.5	2.625	V
$V_{OD}$	Differential output voltage swing	—	247	—	600	mV
$V_{OS}$	Output offset voltage	—	1.125	1.25	1.375	V

Note to Table 3-13:

(1) Supports emulated RSDS output using a three-resistor network (RSDS\_E\_3R).

## Bus Hold Specifications

Table 3-14 lists the bus hold specifications for the MAX V device family.

**Table 3-14. Bus Hold Specifications for MAX V Devices**

Parameter	Conditions	$V_{CCIO}$ Level										Unit
		1.2 V		1.5 V		1.8 V		2.5 V		3.3 V		
		Min	Max	Min	Max	Min	Max	Min	Max	Min	Max	
Low sustaining current	$V_{IN} > V_{IL}$ (maximum)	10	—	20	—	30	—	50	—	70	—	$\mu$ A
High sustaining current	$V_{IN} < V_{IH}$ (minimum)	-10	—	-20	—	-30	—	-50	—	-70	—	$\mu$ A
Low overdrive current	$0 V < V_{IN} < V_{CCIO}$	—	130	—	160	—	200	—	300	—	500	$\mu$ A
High overdrive current	$0 V < V_{IN} < V_{CCIO}$	—	-130	—	-160	—	-200	—	-300	—	-500	$\mu$ A

## Power-Up Timing

Table 3-15 lists the power-up timing characteristics for the MAX V device family.

**Table 3-15. Power-Up Timing for MAX V Devices**

Symbol	Parameter	Device	Temperature Range	Min	Typ	Max	Unit
$t_{\text{CONFIG}}$	The amount of time from when minimum $V_{\text{CCINT}}$ is reached until the device enters user mode (1)	5M40Z	Commercial and industrial	—	—	200	$\mu\text{s}$
			Extended	—	—	300	$\mu\text{s}$
		5M80Z	Commercial and industrial	—	—	200	$\mu\text{s}$
			Extended	—	—	300	$\mu\text{s}$
		5M160Z	Commercial and industrial	—	—	200	$\mu\text{s}$
			Extended	—	—	300	$\mu\text{s}$
		5M240Z (2)	Commercial and industrial	—	—	200	$\mu\text{s}$
			Extended	—	—	300	$\mu\text{s}$
		5M240Z (3)	Commercial and industrial	—	—	300	$\mu\text{s}$
			Extended	—	—	400	$\mu\text{s}$
		5M570Z	Commercial and industrial	—	—	300	$\mu\text{s}$
			Extended	—	—	400	$\mu\text{s}$
		5M1270Z (4)	Commercial and industrial	—	—	300	$\mu\text{s}$
			Extended	—	—	400	$\mu\text{s}$
		5M1270Z (5)	Commercial and industrial	—	—	450	$\mu\text{s}$
			Extended	—	—	500	$\mu\text{s}$
		5M2210Z	Commercial and industrial	—	—	450	$\mu\text{s}$
			Extended	—	—	500	$\mu\text{s}$

**Notes to Table 3-15:**

- (1) For more information about power-on reset (POR) trigger voltage, refer to the *Hot Socketing and Power-On Reset in MAX V Devices* chapter.
- (2) Not applicable to the T144 package of the 5M240Z device.
- (3) Only applicable to the T144 package of the 5M240Z device.
- (4) Not applicable to the F324 package of the 5M1270Z device.
- (5) Only applicable to the F324 package of the 5M1270Z device.

## Power Consumption

You can use the Altera® PowerPlay Early Power Estimator and PowerPlay Power Analyzer to estimate the device power.

- For more information about these power analysis tools, refer to the *PowerPlay Early Power Estimator for Altera CPLDs User Guide* and the *PowerPlay Power Analysis* chapter in volume 3 of the *Quartus II Handbook*.

## Timing Model and Specifications

MAX V devices timing can be analyzed with the Altera Quartus® II software, a variety of industry-standard EDA simulators and timing analyzers, or with the timing model shown in Figure 3-2.

MAX V devices have predictable internal delays that allow you to determine the worst-case timing of any design. The software provides timing simulation, point-to-point delay prediction, and detailed timing analysis for device-wide performance evaluation.

**Figure 3-2. Timing Model for MAX V Devices**

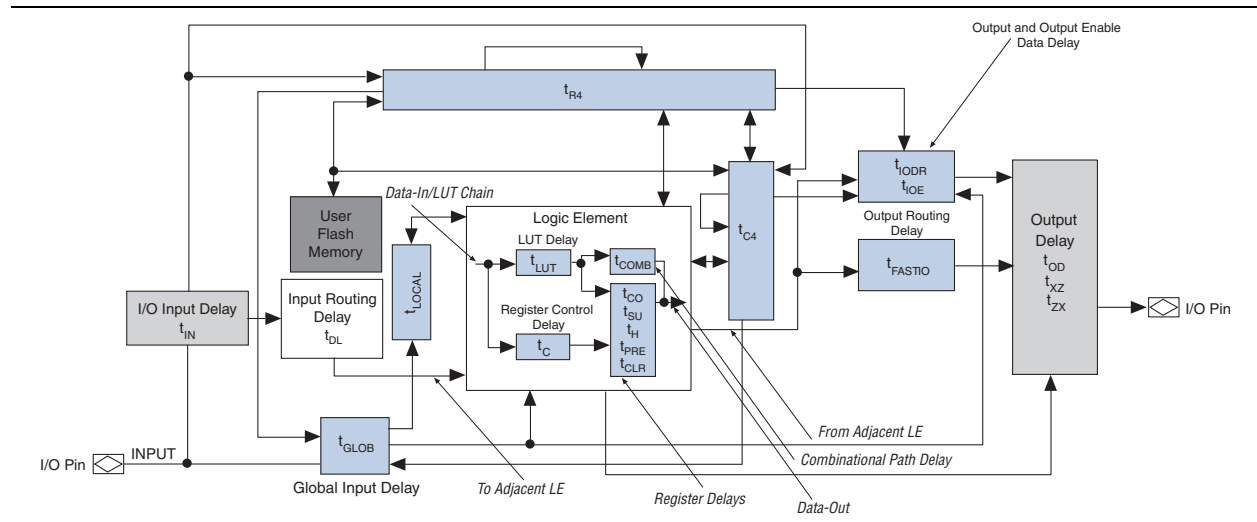

You can derive the timing characteristics of any signal path from the timing model and parameters of a particular device. You can calculate external timing parameters, which represent pin-to-pin timing delays, as the sum of the internal parameters.

- For more information, refer to *AN629: Understanding Timing in Altera CPLDs*.

## Preliminary and Final Timing

This section describes the performance, internal, external, and UFM timing specifications. All specifications are representative of the worst-case supply voltage and junction temperature conditions.

Timing models can have either preliminary or final status. The Quartus II software issues an informational message during the design compilation if the timing models are preliminary. Table 3-16 lists the status of the MAX V device timing models.

Preliminary status means the timing model is subject to change. Initially, timing numbers are created using simulation results, process data, and other known parameters. These tests are used to make the preliminary numbers as close to the actual timing parameters as possible.

Final timing numbers are based on actual device operation and testing. These numbers reflect the actual performance of the device under the worst-case voltage and junction temperature conditions.

**Table 3-16. Timing Model Status for MAX V Devices**

Device	Final
5M40Z	✓
5M80Z	✓
5M160Z	✓
5M240Z	✓
5M570Z	✓
5M1270Z	✓
5M2210Z	✓

## Performance

Table 3-17 lists the MAX V device performance for some common designs. All performance values were obtained with the Quartus II software compilation of megafunctions.

**Table 3-17. Device Performance for MAX V Devices (Part 1 of 2)**

Resource Used	Design Size and Function	Resources Used			Performance				Unit
					5M40Z/ 5M80Z/ 5M160Z/ 5M240Z/ 5M570Z		5M1270Z/ 5M2210Z		
		Mode	LEs	UFM Blocks	C4	C5, I5	C4	C5, I5	
LE	16-bit counter (1)	—	16	0	184.1	118.3	247.5	201.1	MHz
	64-bit counter (1)	—	64	0	83.2	80.5	154.8	125.8	MHz
	16-to-1 multiplexer	—	11	0	17.4	20.4	8.0	9.3	ns
	32-to-1 multiplexer	—	24	0	12.5	25.3	9.0	11.4	ns
	16-bit XOR function	—	5	0	9.0	16.1	6.6	8.2	ns
	16-bit decoder with single address line	—	5	0	9.2	16.1	6.6	8.2	ns

**Table 3-17. Device Performance for MAX V Devices (Part 2 of 2)**

Resource Used	Design Size and Function	Resources Used			Performance				Unit
					5M40Z/ 5M80Z/ 5M160Z/ 5M240Z/ 5M570Z		5M1270Z/ 5M2210Z		
		Mode	LEs	UFM Blocks	C4	C5, I5	C4	C5, I5	
UFM	512 × 16	None	3	1	10.0	10.0	10.0	10.0	MHz
	512 × 16	SPI (2)	37	1	9.7	9.7	8.0	8.0	MHz
	512 × 8	Parallel (3)	73	1	(4)	(4)	(4)	(4)	MHz
	512 × 16	I <sup>2</sup> C (3)	142	1	100 (5)	100 (5)	100 (5)	100 (5)	kHz

**Notes to Table 3-17:**

- (1) This design is a binary loadable up counter.
- (2) This design is configured for read-only operation in Extended mode. Read and write ability increases the number of logic elements (LEs) used.
- (3) This design is configured for read-only operation. Read and write ability increases the number of LEs used.
- (4) This design is asynchronous.
- (5) The I<sup>2</sup>C megafunction is verified in hardware up to 100-kHz serial clock line rate.

## Internal Timing Parameters

Internal timing parameters are specified on a speed grade basis independent of device density. Table 3-18 through Table 3-25 on page 3-19 list the MAX V device internal timing microparameters for LEs, input/output elements (IOEs), UFM blocks, and MultiTrack interconnects.

 For more information about each internal timing microparameters symbol, refer to [AN629: Understanding Timing in Altera CPLDs](#).

**Table 3-18. LE Internal Timing Microparameters for MAX V Devices (Part 1 of 2)**

Symbol	Parameter	5M40Z/ 5M80Z/ 5M160Z/ 5M240Z/ 5M570Z				5M1270Z/ 5M2210Z				Unit
		C4		C5, I5		C4		C5, I5		
		Min	Max	Min	Max	Min	Max	Min	Max	
t <sub>LUT</sub>	LE combinational look-up table (LUT) delay	—	1,215	—	2,247	—	742	—	914	ps
t <sub>COMB</sub>	Combinational path delay	—	243	—	309	—	192	—	236	ps
t <sub>CLR</sub>	LE register clear delay	401	—	545	—	309	—	381	—	ps
t <sub>PRE</sub>	LE register preset delay	401	—	545	—	309	—	381	—	ps
t <sub>SU</sub>	LE register setup time before clock	260	—	321	—	271	—	333	—	ps
t <sub>H</sub>	LE register hold time after clock	0	—	0	—	0	—	0	—	ps
t <sub>CO</sub>	LE register clock-to-output delay	—	380	—	494	—	305	—	376	ps

**Table 3-18. LE Internal Timing Microparameters for MAX V Devices (Part 2 of 2)**

Symbol	Parameter	5M40Z/ 5M80Z/ 5M160Z/ 5M240Z/ 5M570Z				5M1270Z/ 5M2210Z				Unit
		C4		C5, I5		C4		C5, I5		
		Min	Max	Min	Max	Min	Max	Min	Max	
$t_{CLKHL}$	Minimum clock high or low time	253	—	339	—	216	—	266	—	ps
$t_C$	Register control delay	—	1,356	—	1,741	—	1,114	—	1,372	ps

**Table 3-19. IOE Internal Timing Microparameters for MAX V Devices**

Symbol	Parameter	5M40Z/ 5M80Z/ 5M160Z/ 5M240Z/ 5M570Z				5M1270Z/ 5M2210Z				Unit
		C4		C5, I5		C4		C5, I5		
		Min	Max	Min	Max	Min	Max	Min	Max	
$t_{FASTIO}$	Data output delay from adjacent LE to I/O block	—	170	—	428	—	207	—	254	ps
$t_{IN}$	I/O input pad and buffer delay	—	907	—	986	—	920	—	1,132	ps
$t_{GLOB}$ (1)	I/O input pad and buffer delay used as global signal pin	—	2,261	—	3,322	—	1,974	—	2,430	ps
$t_{IOE}$	Internally generated output enable delay	—	530	—	1,410	—	374	—	460	ps
$t_{DL}$	Input routing delay	—	318	—	509	—	291	—	358	ps
$t_{OD}$ (2)	Output delay buffer and pad delay	—	1,319	—	1,543	—	1,383	—	1,702	ps
$t_{XZ}$ (3)	Output buffer disable delay	—	1,045	—	1,276	—	982	—	1,209	ps
$t_{ZX}$ (4)	Output buffer enable delay	—	1,160	—	1,353	—	1,303	—	1,604	ps

**Notes to Table 3-19:**

- (1) Delay numbers for  $t_{GLOB}$  differ for each device density and speed grade. The delay numbers for  $t_{GLOB}$ , shown in Table 3-19, are based on a 5M240Z device target.
- (2) For more information about delay adders associated with different I/O standards, drive strengths, and slew rates, refer to Table 3-34 on page 3-24 and Table 3-35 on page 3-25.
- (3) For more information about  $t_{XZ}$  delay adders associated with different I/O standards, drive strengths, and slew rates, refer to Table 3-22 on page 3-15 and Table 3-23 on page 3-15.
- (4) For more information about  $t_{ZX}$  delay adders associated with different I/O standards, drive strengths, and slew rates, refer to Table 3-20 on page 3-14 and Table 3-21 on page 3-14.

Table 3–20 through Table 3–23 list the adder delays for  $t_{ZX}$  and  $t_{XZ}$  microparameters when using an I/O standard other than 3.3-V LVTTTL with 16 mA drive strength.

**Table 3–20.  $t_{ZX}$  IOE Microparameter Adders for Fast Slew Rate for MAX V Devices**

Standard		5M40Z/ 5M80Z/ 5M160Z/ 5M240Z/ 5M570Z				5M1270Z/ 5M2210Z				Unit
		C4		C5, I5		C4		C5, I5		
		Min	Max	Min	Max	Min	Max	Min	Max	
3.3-V LVTTTL	16 mA	—	0	—	0	—	0	—	0	ps
	8 mA	—	72	—	74	—	101	—	125	ps
3.3-V LVCMOS	8 mA	—	0	—	0	—	0	—	0	ps
	4 mA	—	72	—	74	—	101	—	125	ps
2.5-V LVTTTL / LVCMOS	14 mA	—	126	—	127	—	155	—	191	ps
	7 mA	—	196	—	197	—	545	—	671	ps
1.8-V LVTTTL / LVCMOS	6 mA	—	608	—	610	—	721	—	888	ps
	3 mA	—	681	—	685	—	2012	—	2477	ps
1.5-V LVCMOS	4 mA	—	1162	—	1157	—	1590	—	1957	ps
	2 mA	—	1245	—	1244	—	3269	—	4024	ps
1.2-V LVCMOS	3 mA	—	1889	—	1856	—	2860	—	3520	ps
3.3-V PCI	20 mA	—	72	—	74	—	–18	—	–22	ps
LVDS	—	—	126	—	127	—	155	—	191	ps
RSDS	—	—	126	—	127	—	155	—	191	ps

**Table 3–21.  $t_{ZX}$  IOE Microparameter Adders for Slow Slew Rate for MAX V Devices**

Standard		5M40Z/ 5M80Z/ 5M160Z/ 5M240Z/ 5M570Z				5M1270Z/ 5M2210Z				Unit
		C4		C5, I5		C4		C5, I5		
		Min	Max	Min	Max	Min	Max	Min	Max	
3.3-V LVTTTL	16 mA	—	5,951	—	6,063	—	6,012	—	5,743	ps
	8 mA	—	6,534	—	6,662	—	8,785	—	8,516	ps
3.3-V LVCMOS	8 mA	—	5,951	—	6,063	—	6,012	—	5,743	ps
	4 mA	—	6,534	—	6,662	—	8,785	—	8,516	ps
2.5-V LVTTTL / LVCMOS	14 mA	—	9,110	—	9,237	—	10,072	—	9,803	ps
	7 mA	—	9,830	—	9,977	—	12,945	—	12,676	ps
1.8-V LVTTTL / LVCMOS	6 mA	—	21,800	—	21,787	—	21,185	—	20,916	ps
	3 mA	—	23,020	—	23,037	—	24,597	—	24,328	ps
1.5-V LVCMOS	4 mA	—	39,120	—	39,067	—	34,517	—	34,248	ps
	2 mA	—	40,670	—	40,617	—	39,717	—	39,448	ps
1.2-V LVCMOS	3 mA	—	69,505	—	70,461	—	55,800	—	55,531	ps
3.3-V PCI	20 mA	—	6,534	—	6,662	—	35	—	44	ps

**Table 3–22.  $t_{XZ}$  IOE Microparameter Adders for Fast Slew Rate for MAX V Devices**

Standard		5M40Z/ 5M80Z/ 5M160Z/ 5M240Z/ 5M570Z				5M1270Z/ 5M2210Z				Unit
		C4		C5, I5		C4		C5, I5		
		Min	Max	Min	Max	Min	Max	Min	Max	
3.3-V LVTTTL	16 mA	—	0	—	0	—	0	—	0	ps
	8 mA	—	-69	—	-69	—	-74	—	-91	ps
3.3-V LVCMOS	8 mA	—	0	—	0	—	0	—	0	ps
	4 mA	—	-69	—	-69	—	-74	—	-91	ps
2.5-V LVTTTL / LVCMOS	14 mA	—	-7	—	-10	—	-46	—	-56	ps
	7 mA	—	-66	—	-69	—	-82	—	-101	ps
1.8-V LVTTTL / LVCMOS	6 mA	—	45	—	37	—	-7	—	-8	ps
	3 mA	—	34	—	25	—	119	—	147	ps
1.5-V LVCMOS	4 mA	—	166	—	155	—	339	—	418	ps
	2 mA	—	190	—	179	—	464	—	571	ps
1.2-V LVCMOS	3 mA	—	300	—	283	—	817	—	1,006	ps
3.3-V PCI	20 mA	—	-69	—	-69	—	80	—	99	ps
LVDS	—	—	-7	—	-10	—	-46	—	-56	ps
RSDS	—	—	-7	—	-10	—	-46	—	-56	ps

**Table 3–23.  $t_{XZ}$  IOE Microparameter Adders for Slow Slew Rate for MAX V Devices**

Standard		5M40Z/ 5M80Z/ 5M160Z/ 5M240Z/ 5M570Z				5M1270Z/ 5M2210Z				Unit
		C4		C5, I5		C4		C5, I5		
		Min	Max	Min	Max	Min	Max	Min	Max	
3.3-V LVTTTL	16 mA	—	171	—	174	—	73	—	-132	ps
	8 mA	—	112	—	116	—	758	—	553	ps
3.3-V LVCMOS	8 mA	—	171	—	174	—	73	—	-132	ps
	4 mA	—	112	—	116	—	758	—	553	ps
2.5-V LVTTTL / LVCMOS	14 mA	—	213	—	213	—	32	—	-173	ps
	7 mA	—	166	—	166	—	714	—	509	ps
1.8-V LVTTTL / LVCMOS	6 mA	—	441	—	438	—	96	—	-109	ps
	3 mA	—	496	—	494	—	963	—	758	ps
1.5-V LVCMOS	4 mA	—	765	—	755	—	238	—	33	ps
	2 mA	—	903	—	897	—	1,319	—	1,114	ps
1.2-V LVCMOS	3 mA	—	1,159	—	1,130	—	400	—	195	ps
3.3-V PCI	20 mA	—	112	—	116	—	303	—	373	ps

 The default slew rate setting for MAX V devices in the Quartus II design software is “fast”.

**Table 3-24. UFM Block Internal Timing Microparameters for MAX V Devices (Part 1 of 2)**

Symbol	Parameter	5M40Z/ 5M80Z/ 5M160Z/ 5M240Z/ 5M570Z				5M1270Z/ 5M2210Z				Unit
		C4		C5, I5		C4		C5, I5		
		Min	Max	Min	Max	Min	Max	Min	Max	
$t_{\text{ACLK}}$	Address register clock period	100	—	100	—	100	—	100	—	ns
$t_{\text{ASU}}$	Address register shift signal setup to address register clock	20	—	20	—	20	—	20	—	ns
$t_{\text{AH}}$	Address register shift signal hold to address register clock	20	—	20	—	20	—	20	—	ns
$t_{\text{ADS}}$	Address register data in setup to address register clock	20	—	20	—	20	—	20	—	ns
$t_{\text{ADH}}$	Address register data in hold from address register clock	20	—	20	—	20	—	20	—	ns
$t_{\text{DCLK}}$	Data register clock period	100	—	100	—	100	—	100	—	ns
$t_{\text{DSS}}$	Data register shift signal setup to data register clock	60	—	60	—	60	—	60	—	ns
$t_{\text{DSH}}$	Data register shift signal hold from data register clock	20	—	20	—	20	—	20	—	ns
$t_{\text{DDS}}$	Data register data in setup to data register clock	20	—	20	—	20	—	20	—	ns
$t_{\text{DDH}}$	Data register data in hold from data register clock	20	—	20	—	20	—	20	—	ns
$t_{\text{DP}}$	Program signal to data clock hold time	0	—	0	—	0	—	0	—	ns
$t_{\text{PB}}$	Maximum delay between program rising edge to UFM <i>busy</i> signal rising edge	—	960	—	960	—	960	—	960	ns
$t_{\text{BP}}$	Minimum delay allowed from UFM <i>busy</i> signal going low to program signal going low	20	—	20	—	20	—	20	—	ns
$t_{\text{PPMX}}$	Maximum length of <i>busy</i> pulse during a program	—	100	—	100	—	100	—	100	$\mu\text{s}$

**Table 3-24. UFM Block Internal Timing Microparameters for MAX V Devices (Part 2 of 2)**

Symbol	Parameter	5M40Z/ 5M80Z/ 5M160Z/ 5M240Z/ 5M570Z				5M1270Z/ 5M2210Z				Unit
		C4		C5, I5		C4		C5, I5		
		Min	Max	Min	Max	Min	Max	Min	Max	
$t_{AE}$	Minimum erase signal to address clock hold time	0	—	0	—	0	—	0	—	ns
$t_{EB}$	Maximum delay between the erase rising edge to the UFM busy signal rising edge	—	960	—	960	—	960	—	960	ns
$t_{BE}$	Minimum delay allowed from the UFM busy signal going low to erase signal going low	20	—	20	—	20	—	20	—	ns
$t_{EPMX}$	Maximum length of busy pulse during an erase	—	500	—	500	—	500	—	500	ms
$t_{DCO}$	Delay from data register clock to data register output	—	5	—	5	—	5	—	5	ns
$t_{OE}$	Delay from OSC_ENA signal reaching UFM to rising clock of osc leaving the UFM	180	—	180	—	180	—	180	—	ns
$t_{RA}$	Maximum read access time	—	65	—	65	—	65	—	65	ns
$t_{OSCS}$	Maximum delay between the OSC_ENA rising edge to the erase/program signal rising edge	250	—	250	—	250	—	250	—	ns
$t_{OSCH}$	Minimum delay allowed from the erase/program signal going low to OSC_ENA signal going low	250	—	250	—	250	—	250	—	ns

Figure 3-3 through Figure 3-5 show the read, program, and erase waveforms for UFM block timing parameters listed in Table 3-24.

**Figure 3-3. UFM Read Waveform**

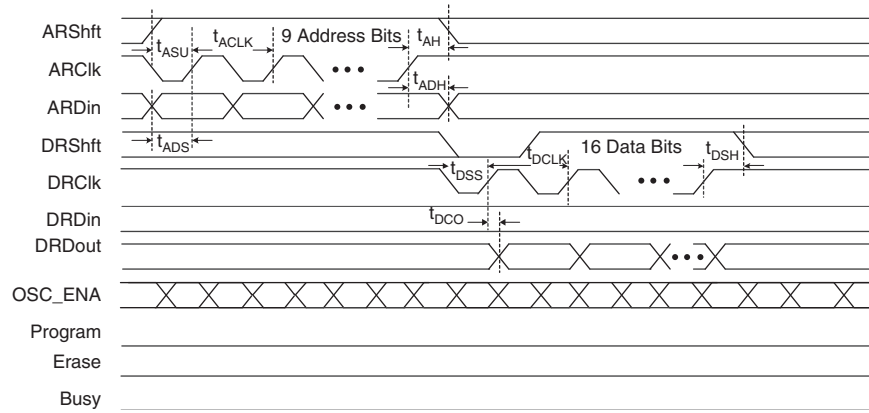

**Figure 3-4. UFM Program Waveform**

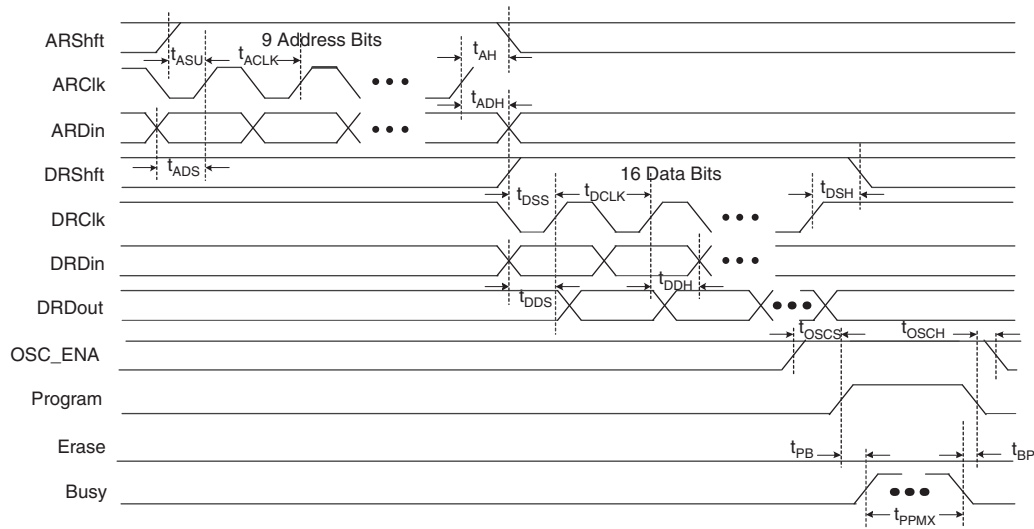

Figure 3-5. UFM Erase Waveform

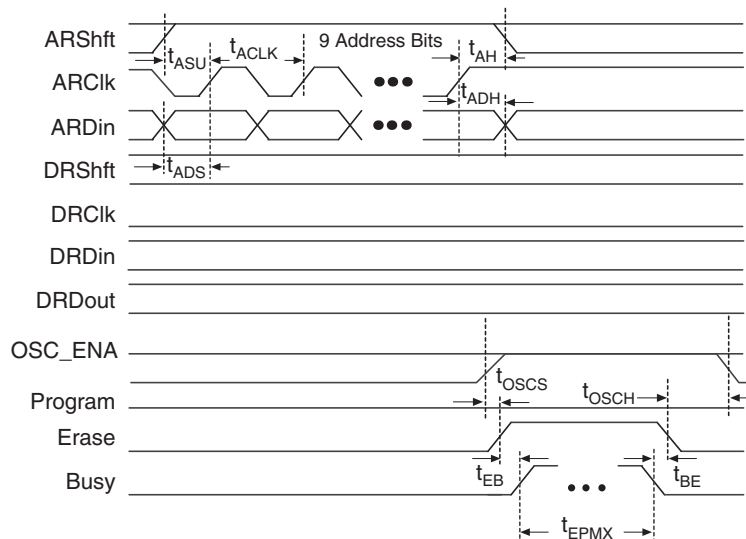

Table 3-25. Routing Delay Internal Timing Microparameters for MAX V Devices

Routing	5M40Z/ 5M80Z/ 5M160Z/ 5M240Z/ 5M570Z				5M1270Z/ 5M2210Z				Unit
	C4		C5, I5		C4		C5, I5		
	Min	Max	Min	Max	Min	Max	Min	Max	
$t_{C4}$	—	860	—	1,973	—	561	—	690	ps
$t_{R4}$	—	655	—	1,479	—	445	—	548	ps
$t_{LOCAL}$	—	1,143	—	2,947	—	731	—	899	ps

## External Timing Parameters

External timing parameters are specified by device density and speed grade. All external I/O timing parameters shown are for the 3.3-V LVTTTL I/O standard with the maximum drive strength and fast slew rate. For external I/O timing using standards other than LVTTTL or for different drive strengths, use the I/O standard input and output delay adders in [Table 3-32 on page 3-23](#) through [Table 3-36 on page 3-25](#).

 For more information about each external timing parameters symbol, refer to [AN629: Understanding Timing in Altera CPLDs](#).

Table 3–26 lists the external I/O timing parameters for the 5M40Z, 5M80Z, 5M160Z, and 5M240Z devices.

**Table 3–26. Global Clock External I/O Timing Parameters for the 5M40Z, 5M80Z, 5M160Z, and 5M240Z Devices**  
(Note 1), (2)

Symbol	Parameter	Condition	C4		C5, I5		Unit
			Min	Max	Min	Max	
$t_{PD1}$	Worst case pin-to-pin delay through one LUT	10 pF	—	7.9	—	14.0	ns
$t_{PD2}$	Best case pin-to-pin delay through one LUT	10 pF	—	5.8	—	8.5	ns
$t_{SU}$	Global clock setup time	—	2.4	—	4.6	—	ns
$t_H$	Global clock hold time	—	0	—	0	—	ns
$t_{CO}$	Global clock to output delay	10 pF	2.0	6.6	2.0	8.6	ns
$t_{CH}$	Global clock high time	—	253	—	339	—	ps
$t_{CL}$	Global clock low time	—	253	—	339	—	ps
$t_{CNT}$	Minimum global clock period for 16-bit counter	—	5.4	—	8.4	—	ns
$f_{CNT}$	Maximum global clock frequency for 16-bit counter	—	—	184.1	—	118.3	MHz

**Notes to Table 3–26:**

- (1) The maximum frequency is limited by the I/O standard on the clock input pin. The 16-bit counter critical delay performs faster than this global clock input pin maximum frequency.
- (2) Not applicable to the T144 package of the 5M240Z device.

Table 3–27 lists the external I/O timing parameters for the T144 package of the 5M240Z device.

**Table 3–27. Global Clock External I/O Timing Parameters for the 5M240Z Device** (Note 1), (2)

Symbol	Parameter	Condition	C4		C5, I5		Unit
			Min	Max	Min	Max	
$t_{PD1}$	Worst case pin-to-pin delay through one LUT	10 pF	—	9.5	—	17.7	ns
$t_{PD2}$	Best case pin-to-pin delay through one LUT	10 pF	—	5.7	—	8.5	ns
$t_{SU}$	Global clock setup time	—	2.2	—	4.4	—	ns
$t_H$	Global clock hold time	—	0	—	0	—	ns
$t_{CO}$	Global clock to output delay	10 pF	2.0	6.7	2.0	8.7	ns
$t_{CH}$	Global clock high time	—	253	—	339	—	ps
$t_{CL}$	Global clock low time	—	253	—	339	—	ps
$t_{CNT}$	Minimum global clock period for 16-bit counter	—	5.4	—	8.4	—	ns
$f_{CNT}$	Maximum global clock frequency for 16-bit counter	—	—	184.1	—	118.3	MHz

**Notes to Table 3–27:**

- (1) The maximum frequency is limited by the I/O standard on the clock input pin. The 16-bit counter critical delay performs faster than this global clock input pin maximum frequency.
- (2) Only applicable to the T144 package of the 5M240Z device.

Table 3–28 lists the external I/O timing parameters for the 5M570Z device.

**Table 3–28. Global Clock External I/O Timing Parameters for the 5M570Z Device (Note 1)**

Symbol	Parameter	Condition	C4		C5, I5		Unit
			Min	Max	Min	Max	
$t_{PD1}$	Worst case pin-to-pin delay through one LUT	10 pF	—	9.5	—	17.7	ns
$t_{PD2}$	Best case pin-to-pin delay through one LUT	10 pF	—	5.7	—	8.5	ns
$t_{SU}$	Global clock setup time	—	2.2	—	4.4	—	ns
$t_H$	Global clock hold time	—	0	—	0	—	ns
$t_{CO}$	Global clock to output delay	10 pF	2.0	6.7	2.0	8.7	ns
$t_{CH}$	Global clock high time	—	253	—	339	—	ps
$t_{CL}$	Global clock low time	—	253	—	339	—	ps
$t_{CNT}$	Minimum global clock period for 16-bit counter	—	5.4	—	8.4	—	ns
$f_{CNT}$	Maximum global clock frequency for 16-bit counter	—	—	184.1	—	118.3	MHz

**Note to Table 3–28:**

- (1) The maximum frequency is limited by the I/O standard on the clock input pin. The 16-bit counter critical delay performs faster than this global clock input pin maximum frequency.

Table 3–29 lists the external I/O timing parameters for the 5M1270Z device.

**Table 3–29. Global Clock External I/O Timing Parameters for the 5M1270Z Device (Note 1), (2)**

Symbol	Parameter	Condition	C4		C5, I5		Unit
			Min	Max	Min	Max	
$t_{PD1}$	Worst case pin-to-pin delay through one LUT	10 pF	—	8.1	—	10.0	ns
$t_{PD2}$	Best case pin-to-pin delay through one LUT	10 pF	—	4.8	—	5.9	ns
$t_{SU}$	Global clock setup time	—	1.5	—	1.9	—	ns
$t_H$	Global clock hold time	—	0	—	0	—	ns
$t_{CO}$	Global clock to output delay	10 pF	2.0	5.9	2.0	7.3	ns
$t_{CH}$	Global clock high time	—	216	—	266	—	ps
$t_{CL}$	Global clock low time	—	216	—	266	—	ps
$t_{CNT}$	Minimum global clock period for 16-bit counter	—	4.0	—	5.0	—	ns
$f_{CNT}$	Maximum global clock frequency for 16-bit counter	—	—	247.5	—	201.1	MHz

**Notes to Table 3–29:**

- (1) The maximum frequency is limited by the I/O standard on the clock input pin. The 16-bit counter critical delay performs faster than this global clock input pin maximum frequency.  
 (2) Not applicable to the F324 package of the 5M1270Z device.

Table 3-30 lists the external I/O timing parameters for the F324 package of the 5M1270Z device.

**Table 3-30. Global Clock External I/O Timing Parameters for the 5M1270Z Device (Note 1), (2)**

Symbol	Parameter	Condition	C4		C5, I5		Unit
			Min	Max	Min	Max	
$t_{PD1}$	Worst case pin-to-pin delay through one LUT	10 pF	—	9.1	—	11.2	ns
$t_{PD2}$	Best case pin-to-pin delay through one LUT	10 pF	—	4.8	—	5.9	ns
$t_{SU}$	Global clock setup time	—	1.5	—	1.9	—	ns
$t_H$	Global clock hold time	—	0	—	0	—	ns
$t_{CO}$	Global clock to output delay	10 pF	2.0	6.0	2.0	7.4	ns
$t_{CH}$	Global clock high time	—	216	—	266	—	ps
$t_{CL}$	Global clock low time	—	216	—	266	—	ps
$t_{CNT}$	Minimum global clock period for 16-bit counter	—	4.0	—	5.0	—	ns
$f_{CNT}$	Maximum global clock frequency for 16-bit counter	—	—	247.5	—	201.1	MHz

**Notes to Table 3-30:**

- (1) The maximum frequency is limited by the I/O standard on the clock input pin. The 16-bit counter critical delay performs faster than this global clock input pin maximum frequency.
- (2) Only applicable to the F324 package of the 5M1270Z device.

Table 3-31 lists the external I/O timing parameters for the 5M2210Z device.

**Table 3-31. Global Clock External I/O Timing Parameters for the 5M2210Z Device (Note 1)**

Symbol	Parameter	Condition	C4		C5, I5		Unit
			Min	Max	Min	Max	
$t_{PD1}$	Worst case pin-to-pin delay through one LUT	10 pF	—	9.1	—	11.2	ns
$t_{PD2}$	Best case pin-to-pin delay through one LUT	10 pF	—	4.8	—	5.9	ns
$t_{SU}$	Global clock setup time	—	1.5	—	1.9	—	ns
$t_H$	Global clock hold time	—	0	—	0	—	ns
$t_{CO}$	Global clock to output delay	10 pF	2.0	6.0	2.0	7.4	ns
$t_{CH}$	Global clock high time	—	216	—	266	—	ps
$t_{CL}$	Global clock low time	—	216	—	266	—	ps
$t_{CNT}$	Minimum global clock period for 16-bit counter	—	4.0	—	5.0	—	ns
$f_{CNT}$	Maximum global clock frequency for 16-bit counter	—	—	247.5	—	201.1	MHz

**Note to Table 3-31:**

- (1) The maximum frequency is limited by the I/O standard on the clock input pin. The 16-bit counter critical delay performs faster than this global clock input pin maximum frequency.

## External Timing I/O Delay Adders

The I/O delay timing parameters for the I/O standard input and output adders and the input delays are specified by speed grade, independent of device density.

Table 3-32 through Table 3-36 on page 3-25 list the adder delays associated with I/O pins for all packages. If you select an I/O standard other than 3.3-V LVTTTL, add the input delay adder to the external  $t_{SU}$  timing parameters listed in Table 3-26 on page 3-20 through Table 3-31. If you select an I/O standard other than 3.3-V LVTTTL with 16 mA drive strength and fast slew rate, add the output delay adder to the external  $t_{CO}$  and  $t_{PD}$  listed in Table 3-26 on page 3-20 through Table 3-31.

**Table 3-32. External Timing Input Delay Adders for MAX V Devices**

I/O Standard		5M40Z/ 5M80Z/ 5M160Z/ 5M240Z/ 5M570Z				5M1270Z/ 5M2210Z				Unit
		C4		C5, I5		C4		C5, I5		
		Min	Max	Min	Max	Min	Max	Min	Max	
3.3-V LVTTTL	Without Schmitt Trigger	—	0	—	0	—	0	—	0	ps
	With Schmitt Trigger	—	387	—	442	—	480	—	591	ps
3.3-V LVCMOS	Without Schmitt Trigger	—	0	—	0	—	0	—	0	ps
	With Schmitt Trigger	—	387	—	442	—	480	—	591	ps
2.5-V LVTTTL / LVCMOS	Without Schmitt Trigger	—	42	—	42	—	246	—	303	ps
	With Schmitt Trigger	—	429	—	483	—	787	—	968	ps
1.8-V LVTTTL / LVCMOS	Without Schmitt Trigger	—	378	—	368	—	695	—	855	ps
1.5-V LVCMOS	Without Schmitt Trigger	—	681	—	658	—	1,334	—	1,642	ps
1.2-V LVCMOS	Without Schmitt Trigger	—	1,055	—	1,010	—	2,324	—	2,860	ps
3.3-V PCI	Without Schmitt Trigger	—	0	—	0	—	0	—	0	ps

**Table 3-33. External Timing Input Delay  $t_{GLOB}$  Adders for GCLK Pins for MAX V Devices (Part 1 of 2)**

I/O Standard		5M40Z/ 5M80Z/ 5M160Z/ 5M240Z/ 5M570Z				5M1270Z/ 5M2210Z				Unit
		C4		C5, I5		C4		C5, I5		
		Min	Max	Min	Max	Min	Max	Min	Max	
3.3-V LVTTTL	Without Schmitt Trigger	—	0	—	0	—	0	—	0	ps
	With Schmitt Trigger	—	387	—	442	—	400	—	493	ps

**Table 3-33. External Timing Input Delay  $t_{GLOB}$  Adders for GCLK Pins for MAX V Devices (Part 2 of 2)**

I/O Standard		5M40Z/ 5M80Z/ 5M160Z/ 5M240Z/ 5M570Z				5M1270Z/ 5M2210Z				Unit
		C4		C5, I5		C4		C5, I5		
		Min	Max	Min	Max	Min	Max	Min	Max	
3.3-V LVCMOS	Without Schmitt Trigger	—	0	—	0	—	0	—	0	ps
	With Schmitt Trigger	—	387	—	442	—	400	—	493	ps
2.5-V LVTTTL / LVCMOS	Without Schmitt Trigger	—	242	—	242	—	287	—	353	ps
	With Schmitt Trigger	—	429	—	483	—	550	—	677	ps
1.8-V LVTTTL / LVCMOS	Without Schmitt Trigger	—	378	—	368	—	459	—	565	ps
1.5-V LVCMOS	Without Schmitt Trigger	—	681	—	658	—	1,111	—	1,368	ps
1.2-V LVCMOS	Without Schmitt Trigger	—	1,055	—	1,010	—	2,067	—	2,544	ps
3.3-V PCI	Without Schmitt Trigger	—	0	—	0	—	7	—	9	ps

**Table 3-34. External Timing Output Delay and  $t_{OD}$  Adders for Fast Slew Rate for MAX V Devices**

I/O Standard		5M40Z/ 5M80Z/ 5M160Z/ 5M240Z/ 5M570Z				5M1270Z/ 5M2210Z				Unit
		C4		C5, I5		C4		C5, I5		
		Min	Max	Min	Max	Min	Max	Min	Max	
3.3-V LVTTTL	16 mA	—	0	—	0	—	0	—	0	ps
	8 mA	—	39	—	58	—	84	—	104	ps
3.3-V LVCMOS	8 mA	—	0	—	0	—	0	—	0	ps
	4 mA	—	39	—	58	—	84	—	104	ps
2.5-V LVTTTL / LVCMOS	14 mA	—	122	—	129	—	158	—	195	ps
	7 mA	—	196	—	188	—	251	—	309	ps
1.8-V LVTTTL / LVCMOS	6 mA	—	624	—	624	—	738	—	909	ps
	3 mA	—	686	—	694	—	850	—	1,046	ps
1.5-V LVCMOS	4 mA	—	1,188	—	1,184	—	1,376	—	1,694	ps
	2 mA	—	1,279	—	1,280	—	1,517	—	1,867	ps
1.2-V LVCMOS	3 mA	—	1,911	—	1,883	—	2,206	—	2,715	ps
3.3-V PCI	20 mA	—	39	—	58	—	4	—	5	ps
LVDS	—	—	122	—	129	—	158	—	195	ps
RSDS	—	—	122	—	129	—	158	—	195	ps

**Table 3–35. External Timing Output Delay and  $t_{0D}$  Adders for Slow Slew Rate for MAX V Devices**

I/O Standard		5M40Z/ 5M80Z/ 5M160Z/ 5M240Z/ 5M570Z				5M1270Z/ 5M2210Z				Unit
		C4		C5, I5		C4		C5, I5		
		Min	Max	Min	Max	Min	Max	Min	Max	
3.3-V LVTTTL	16 mA	—	5,913	—	6,043	—	6,612	—	6,293	ps
	8 mA	—	6,488	—	6,645	—	7,313	—	6,994	ps
3.3-V LVCMOS	8 mA	—	5,913	—	6,043	—	6,612	—	6,293	ps
	4 mA	—	6,488	—	6,645	—	7,313	—	6,994	ps
2.5-V LVTTTL / LVCMOS	14 mA	—	9,088	—	9,222	—	10,021	—	9,702	ps
	7 mA	—	9,808	—	9,962	—	10,881	—	10,562	ps
1.8-V LVTTTL / LVCMOS	6 mA	—	21,758	—	21,782	—	21,134	—	20,815	ps
	3 mA	—	23,028	—	23,032	—	22,399	—	22,080	ps
1.5-V LVCMOS	4 mA	—	39,068	—	39,032	—	34,499	—	34,180	ps
	2 mA	—	40,578	—	40,542	—	36,281	—	35,962	ps
1.2-V LVCMOS	3 mA	—	69,332	—	70,257	—	55,796	—	55,477	ps
3.3-V PCI	20 mA	—	6,488	—	6,645	—	339	—	418	ps

**Table 3–36. IOE Programmable Delays for MAX V Devices**

Parameter	5M40Z/ 5M80Z/ 5M160Z/ 5M240Z/ 5M570Z				5M1270Z/ 5M2210Z				Unit
	C4		C5, I5		C4		C5, I5		
	Min	Max	Min	Max	Min	Max	Min	Max	
Input Delay from Pin to Internal Cells = 1	—	1,858	—	2,214	—	1,592	—	1,960	ps
Input Delay from Pin to Internal Cells = 0	—	569	—	616	—	115	—	142	ps

## Maximum Input and Output Clock Rates

Table 3-37 and Table 3-38 list the maximum input and output clock rates for standard I/O pins in MAX V devices.

**Table 3-37. Maximum Input Clock Rate for I/Os for MAX V Devices**

I/O Standard		5M40Z/ 5M80Z/ 5M160Z/ 5M240Z/ 5M570Z/5M1270Z/ 5M2210Z	Unit
		C4, C5, I5	
3.3-V LVTTTL	Without Schmitt Trigger	304	MHz
	With Schmitt Trigger	304	MHz
3.3-V LVCMOS	Without Schmitt Trigger	304	MHz
	With Schmitt Trigger	304	MHz
2.5-V LVTTTL	Without Schmitt Trigger	304	MHz
	With Schmitt Trigger	304	MHz
2.5-V LVCMOS	Without Schmitt Trigger	304	MHz
	With Schmitt Trigger	304	MHz
1.8-V LVTTTL	Without Schmitt Trigger	200	MHz
1.8-V LVCMOS	Without Schmitt Trigger	200	MHz
1.5-V LVCMOS	Without Schmitt Trigger	150	MHz
1.2-V LVCMOS	Without Schmitt Trigger	120	MHz
3.3-V PCI	Without Schmitt Trigger	304	MHz

**Table 3-38. Maximum Output Clock Rate for I/Os for MAX V Devices**

I/O Standard		5M40Z/ 5M80Z/ 5M160Z/ 5M240Z/ 5M570Z/5M1270Z/ 5M2210Z	Unit
		C4, C5, I5	
3.3-V LVTTTL		304	MHz
3.3-V LVCMOS		304	MHz
2.5-V LVTTTL		304	MHz
2.5-V LVCMOS		304	MHz
1.8-V LVTTTL		200	MHz
1.8-V LVCMOS		200	MHz
1.5-V LVCMOS		150	MHz
1.2-V LVCMOS		120	MHz
3.3-V PCI		304	MHz
LVDS		304	MHz
RSDS		200	MHz

## LVDS and RSDS Output Timing Specifications

Table 3-39 lists the emulated LVDS output timing specifications for MAX V devices.

**Table 3-39. Emulated LVDS Output Timing Specifications for MAX V Devices**

Parameter	Mode	5M40Z/ 5M80Z/ 5M160Z/ 5M240Z/ 5M570Z/5M1270Z/ 5M2210Z		Unit
		C4, C5, I5		
		Min	Max	
Data rate (1), (2)	×10	—	304	Mbps
	×9	—	304	Mbps
	×8	—	304	Mbps
	×7	—	304	Mbps
	×6	—	304	Mbps
	×5	—	304	Mbps
	×4	—	304	Mbps
	×3	—	304	Mbps
	×2	—	304	Mbps
×1	—	304	Mbps	
t <sub>DUTY</sub>	—	45	55	%
Total jitter (3)	—	—	0.2	UI
t <sub>RISE</sub>	—	—	450	ps
t <sub>FALL</sub>	—	—	450	ps

**Notes to Table 3-39:**

- (1) The performance of the LVDS\_E\_3R transmitter system is limited by the lower of the two—the maximum data rate supported by LVDS\_E\_3R I/O buffer or 2x (F<sub>MAX</sub> of the ALTLVDS\_TX instance). The actual performance of your LVDS\_E\_3R transmitter system must be attained through the Quartus II timing analysis of the complete design.
- (2) For the input clock pin to achieve 304 Mbps, use I/O standard with V<sub>CCIO</sub> of 2.5 V and above.
- (3) This specification is based on external clean clock source.

Table 3-40 lists the emulated RSDS output timing specifications for MAX V devices.

**Table 3-40. Emulated RSDS Output Timing Specifications for MAX V Devices**

Parameter	Mode	5M40Z/ 5M80Z/ 5M160Z/ 5M240Z/ 5M570Z/5M1270Z/ 5M2210Z		Unit
		C4, C5, I5		
		Min	Max	
Data rate (1)	×10	—	200	Mbps
	×9	—	200	Mbps
	×8	—	200	Mbps
	×7	—	200	Mbps
	×6	—	200	Mbps
	×5	—	200	Mbps
	×4	—	200	Mbps
	×3	—	200	Mbps
	×2	—	200	Mbps
	×1	—	200	Mbps
$t_{DUTY}$	—	45	55	%
Total jitter (2)	—	—	0.2	UI
$t_{RISE}$	—	—	450	ps
$t_{FALL}$	—	—	450	ps

**Notes to Table 3-40:**

- (1) For the input clock pin to achieve 200 Mbps, use I/O standard with  $V_{CCIO}$  of 1.8 V and above.
- (2) This specification is based on external clean clock source.

## JTAG Timing Specifications

Figure 3-6 shows the timing waveform for the JTAG signals for the MAX V device family.

Figure 3-6. JTAG Timing Waveform for MAX V Devices

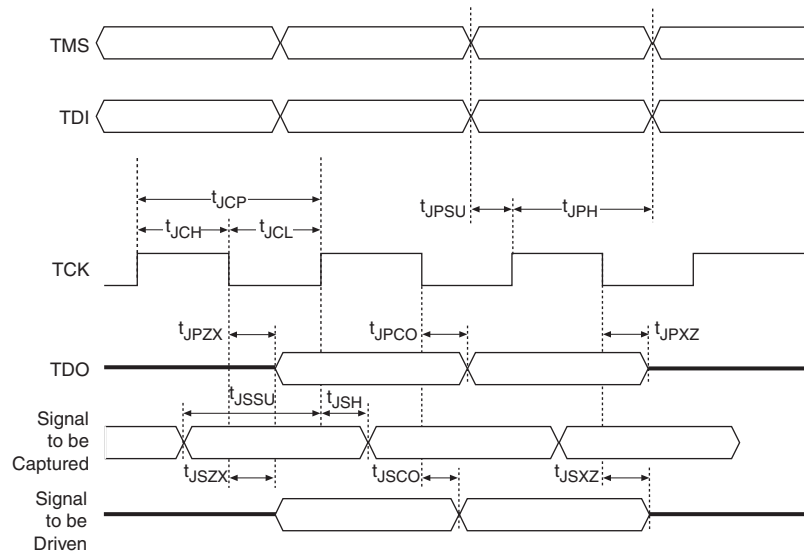

Table 3-41 lists the JTAG timing parameters and values for the MAX V device family.

Table 3-41. JTAG Timing Parameters for MAX V Devices (Part 1 of 2)

Symbol	Parameter	Min	Max	Unit
$t_{JCP}$ (1)	TCK clock period for $V_{CCI01} = 3.3$ V	55.5	—	ns
	TCK clock period for $V_{CCI01} = 2.5$ V	62.5	—	ns
	TCK clock period for $V_{CCI01} = 1.8$ V	100	—	ns
	TCK clock period for $V_{CCI01} = 1.5$ V	143	—	ns
$t_{JCH}$	TCK clock high time	20	—	ns
$t_{JCL}$	TCK clock low time	20	—	ns
$t_{JPSU}$	JTAG port setup time (2)	8	—	ns
$t_{JPH}$	JTAG port hold time	10	—	ns
$t_{JPCO}$	JTAG port clock to output (2)	—	15	ns
$t_{JPZX}$	JTAG port high impedance to valid output (2)	—	15	ns
$t_{JPXZ}$	JTAG port valid output to high impedance (2)	—	15	ns
$t_{JSSU}$	Capture register setup time	8	—	ns
$t_{JSH}$	Capture register hold time	10	—	ns
$t_{JSCO}$	Update register clock to output	—	25	ns
$t_{JSZX}$	Update register high impedance to valid output	—	25	ns

**Table 3-41. JTAG Timing Parameters for MAX V Devices (Part 2 of 2)**

Symbol	Parameter	Min	Max	Unit
$t_{JSXZ}$	Update register valid output to high impedance	—	25	ns

**Notes to Table 3-41:**

- (1) Minimum clock period specified for 10 pF load on the TDO pin. Larger loads on TDO degrades the maximum TCK frequency.
- (2) This specification is shown for 3.3-V LVTTTL/LVCMOS and 2.5-V LVTTTL/LVCMOS operation of the JTAG pins. For 1.8-V LVTTTL/LVCMOS and 1.5-V LVCMOS operation, the  $t_{JPSU}$  minimum is 6 ns and  $t_{JPCO}$ ,  $t_{JPZX}$ , and  $t_{JPXZ}$  are maximum values at 35 ns.

## Document Revision History

Table 3-42 lists the revision history for this chapter.

**Table 3-42. Document Revision History**

Date	Version	Changes
May 2011	1.2	Updated Table 3-2, Table 3-15, Table 3-16, and Table 3-33.
January 2011	1.1	Updated Table 3-37, Table 3-38, Table 3-39, and Table 3-40.
December 2010	1.0	Initial release.

This section provides information about system integration in MAX<sup>®</sup> V devices.

This section includes the following chapters:

- [Chapter 4, Hot Socketing and Power-On Reset in MAX V Devices](#)
- [Chapter 5, Using MAX V Devices in Multi-Voltage Systems](#)
- [Chapter 6, JTAG and In-System Programmability in MAX V Devices](#)
- [Chapter 7, User Flash Memory in MAX V Devices](#)
- [Chapter 8, JTAG Boundary-Scan Testing in MAX V Devices](#)



This chapter provides information about hot-socketing specifications, power-on reset (POR) requirements, and their implementation in MAX<sup>®</sup> V devices.

MAX V devices offer hot socketing, also known as hot plug-in or hot swap, and power sequencing support. You can insert or remove a MAX V device in a system during system operation without causing undesirable effects to the running system bus. The hot-socketing feature removes some of the difficulty when using MAX V devices on PCBs that contain a mixture of 3.3-, 2.5-, 1.8-, and 1.5-V devices.

The MAX V hot-socketing feature provides the following:

- Board or device insertion and removal
- Support for any power-up sequence
- Non-intrusive I/O buffers to system buses during hot insertion

This chapter contains the following sections:

- “MAX V Hot-Socketing Specifications” on page 4-1
- “Hot-Socketing Feature Implementation in MAX V Devices” on page 4-3
- “Power-On Reset Circuitry” on page 4-5

### MAX V Hot-Socketing Specifications

MAX V devices offer the hot-socketing feature without the need for external components or special design requirements. The advantages of hot-socketing support in MAX V devices includes the following:

- The device can be driven before and during power up or power down without damaging the device.
- I/O pins remain tri-stated during power up. The device does not drive out before or during power up, thereby affecting other operating buses.
- Signal pins do not drive the  $V_{CCIO}$  or  $V_{CCINT}$  power supplies. External input signals to the device I/O pins do not power the device  $V_{CCIO}$  or  $V_{CCINT}$  power supplies using internal paths. This is true if the  $V_{CCINT}$  and  $V_{CCIO}$  power supplies are held at GND.



Altera uses GND as a reference for the hot-socketing and I/O buffers circuitry designs. To ensure device reliability and compliance to the hot-socketing specifications, you must connect GND between boards before connecting the  $V_{CCINT}$  and  $V_{CCIO}$  power supplies.

## Devices Can Be Driven Before Power Up

You can drive signals into the I/O pins and GCLK[3..0] pins of MAX V devices before or during power up or power down without damaging the device. To simplify the system-level design, MAX V devices support any power-up or power-down sequence ( $V_{CCIO1}$ ,  $V_{CCIO2}$ ,  $V_{CCIO3}$ ,  $V_{CCIO4}$ , and  $V_{CCINT}$ ).

## I/O Pins Remain Tri-Stated During Power Up

A device that does not support hot socketing may interrupt system operation or cause contention by driving out before or during power up. In a hot-socketing situation, the MAX V device's output buffers are turned off during system power up. MAX V devices do not drive out until the device attains proper operating conditions and is fully configured. For more information about turn-on voltages, refer to [“Power-On Reset Circuitry” on page 4-5](#).

## Signal Pins Do Not Drive the $V_{CCIO}$ or $V_{CCINT}$ Power Supplies

MAX V devices do not have a current path from the I/O pins or GCLK[3..0] pins to the  $V_{CCIO}$  or  $V_{CCINT}$  power supplies before or during power up. A MAX V device may be inserted into (or removed from) a system board that is powered up without damaging or interfering with system-board operation. When hot socketing, MAX V devices may have a minimal effect on the signal integrity of the backplane.

## AC and DC Specifications

You can power up or power down the  $V_{CCIO}$  and  $V_{CCINT}$  power supplies in any sequence. During hot socketing, the I/O pin capacitance is less than 8 pF. MAX V devices meet the following hot-socketing specifications:

- DC specification:  $|I_{IOPIN}| < 300 \mu\text{A}$ .
- AC specification:  $|I_{IOPIN}| < 8 \text{ mA}$  for 10 ns or less.



MAX V devices are immune to latch-up when hot socketing. If the TCK JTAG input pin is driven high during hot socketing, the current on that pin might exceed the specifications listed above.

$I_{IOPIN}$  is the current for any user I/O pin on the device. The AC specification applies when the device is being powered up or powered down. This specification takes into account the pin capacitance but not the board trace and external loading capacitance. You must consider additional capacitance for trace, connector, and loading separately. The peak current duration due to power-up transients is 10 ns or less.

The DC specification applies when all  $V_{CC}$  supplies to the device are stable in the powered-up or powered-down conditions.

## Hot-Socketing Feature Implementation in MAX V Devices

The hot-socketing feature tri-states the output buffer during the power-up event (either the  $V_{CCINT}$  or  $V_{CCIO}$  power supplies) or power-down event. The hot-socketing circuitry generates an internal `HOTSCKT` signal when either  $V_{CCINT}$  or  $V_{CCIO}$  is below the threshold voltage during power up or power down. The `HOTSCKT` signal cuts off the output buffer to ensure that no DC current leaks through the pin (except for weak pull-up leaking). When  $V_{CC}$  ramps up very slowly during power up,  $V_{CC}$  may still be relatively low even after the POR signal is released and device configuration is complete.

 Ensure that  $V_{CCINT}$  is within the recommended operating range even though SRAM download has completed.

Figure 4–1 shows the circuitry for each I/O and clock pin.

Figure 4–1. Hot-Socketing Circuitry for MAX V Devices

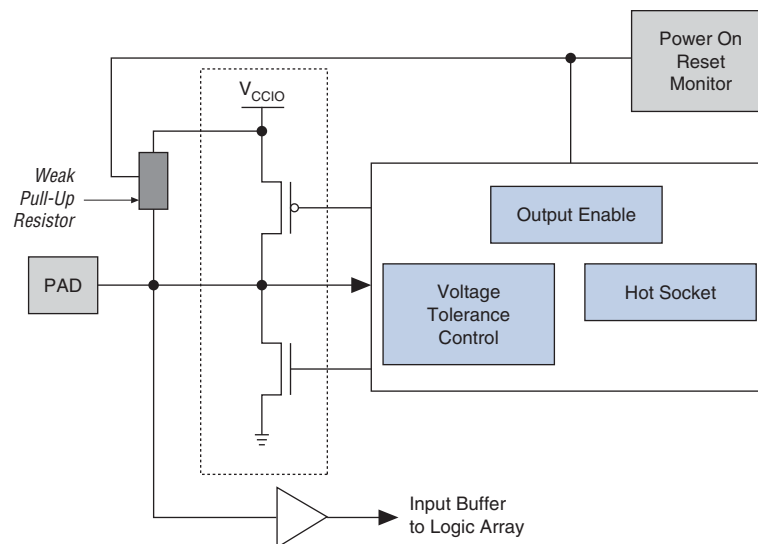

The POR circuit monitors the  $V_{CCINT}$  and  $V_{CCIO}$  voltage levels and keeps the I/O pins tri-stated until the device has completed its flash memory configuration of the SRAM logic. The weak pull-up resistor (R) from the I/O pin to  $V_{CCIO}$  is enabled during download to keep the I/O pins from floating. The 3.3-V tolerance control circuit permits the I/O pins to be driven by 3.3 V before  $V_{CCIO}$  and/or  $V_{CCINT}$  are powered, and it prevents the I/O pins from driving out when the device is not fully powered or operational. The hot-socketing circuitry prevents the I/O pins from internally powering  $V_{CCIO}$  and  $V_{CCINT}$  when driven by external signals before the device is powered.

 For more information about the 5.0-V tolerance, refer to the *Using MAX V Devices in Multi-Voltage Systems* chapter.

Figure 4-2 shows a transistor-level cross section of the MAX V device I/O buffers. This design ensures that the output buffers do not drive when  $V_{CCIO}$  is powered before  $V_{CCINT}$  or if the I/O pad voltage is higher than  $V_{CCIO}$ . This also applies for sudden voltage spikes during hot insertion. The  $V_{PAD}$  leakage current charges the 3.3-V tolerant circuit capacitance.

Figure 4-2. Transistor-Level I/O Buffers for MAX V Devices

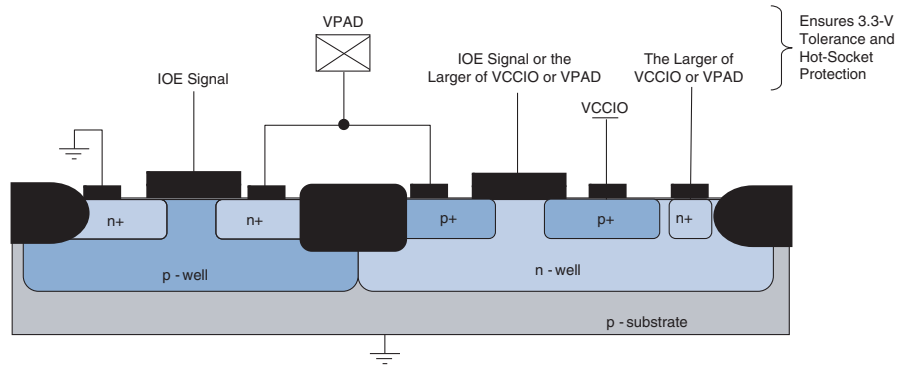

The CMOS output drivers in the I/O pins intrinsically provide electrostatic discharge (ESD) protection. There are two cases to consider for ESD voltage strikes—positive voltage zap and negative voltage zap.

A positive ESD voltage zap occurs when a positive voltage is present on an I/O pin due to an ESD charge event. This can cause the N+ (Drain)/ P-Substrate junction of the N-channel drain to break down and the N+ (Drain)/P-Substrate/N+ (Source) intrinsic bipolar transistor turn on to discharge ESD current from I/O pin to GND. The dashed line in Figure 4-3 shows the ESD current discharge path during a positive ESD zap.

Figure 4-3. ESD Protection During Positive Voltage Zap

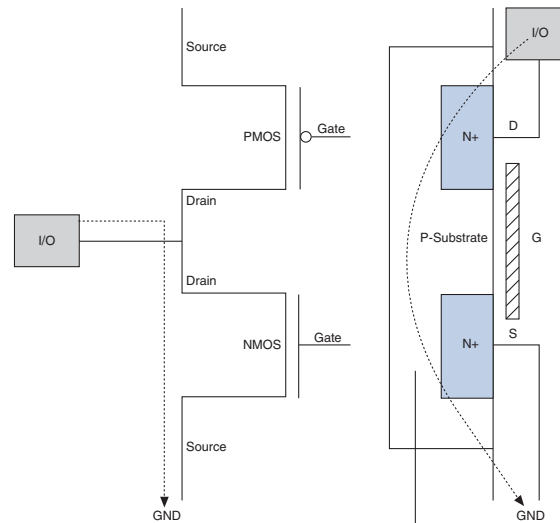

When the I/O pin receives a negative ESD zap at the pin that is less than  $-0.7\text{ V}$  ( $0.7\text{ V}$  is the voltage drop across a diode), the intrinsic P-Substrate/N+ drain diode is forward biased. Therefore, the discharge ESD current path is from GND to the I/O pin, as shown in Figure 4-4.

Figure 4-4. ESD Protection During Negative Voltage Zap

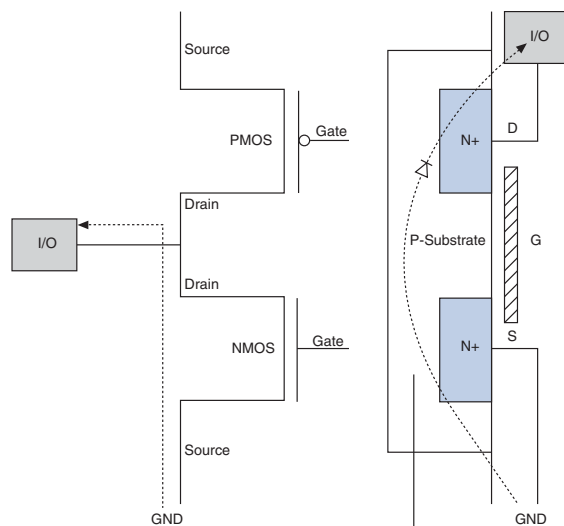

## Power-On Reset Circuitry

MAX V devices have POR circuits to monitor the  $V_{CCINT}$  and  $V_{CCIO}$  voltage levels during power up. The POR circuit monitors these voltages, triggering download from the non-volatile configuration flash memory block to the SRAM logic, maintaining the tri-state of the I/O pins (with weak pull-up resistors enabled) before and during this process. When the MAX V device enters user mode, the POR circuit releases the I/O pins to user functionality. The POR circuit of the MAX V device does not monitor the  $V_{CCINT}$  voltage level after the device enters into user mode.

## Power-Up Characteristics

When power is applied to a MAX V device, the POR circuit monitors  $V_{CCINT}$  and begins SRAM download at  $1.55\text{ V}$  for MAX V devices. From this voltage reference, the SRAM download and entry into user mode takes 200 to  $450\text{ }\mu\text{s}$  maximum, depending on your device density. This period of time is specified as  $t_{CONFIG}$  in the power-up timing section of the *DC and Switching Characteristics for MAX V Devices* chapter.

Entry into user mode is gated by whether all the  $V_{CCIO}$  banks are powered with sufficient operating voltage. If  $V_{CCINT}$  and  $V_{CCIO}$  are powered simultaneously, the device enters user mode within the  $t_{CONFIG}$  specifications. If  $V_{CCIO}$  is powered more than  $t_{CONFIG}$  after  $V_{CCINT}$ , the device does not enter user mode until  $2\text{ }\mu\text{s}$  after all  $V_{CCIO}$  banks are powered.

For MAX V devices, the POR circuitry does not monitor the  $V_{CCINT}$  and  $V_{CCIO}$  voltage levels after the device enters user mode. If there is a  $V_{CCINT}$  voltage sag below 1.4 V during user mode, the functionality of the device is not guaranteed and you must power down  $V_{CCINT}$  to 250 mV for a minimum of 10  $\mu$ s before powering  $V_{CCINT}$  and  $V_{CCIO}$  up again. After  $V_{CCINT}$  rises from 250 mV back to approximately 1.55 V, the SRAM download restarts and the device begins to operate after the  $t_{CONFIG}$  time has passed.

Figure 4-5 shows the voltages for POR of MAX V devices during power up into user mode and from user mode to power down or brown out.

 All  $V_{CCINT}$  and  $V_{CCIO}$  power supplies of all banks must be powered on before entering user mode.

**Figure 4-5. Power-Up Characteristics for MAX V Devices (Note 1), (2)**

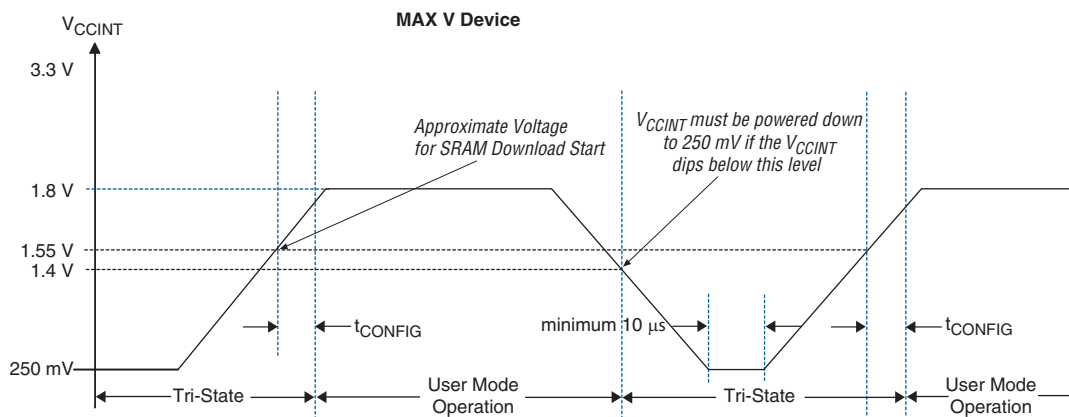

**Notes to Figure 4-5:**

- (1) Time scale is relative.
- (2) For this figure, all the  $V_{CCIO}$  banks are powered up simultaneously with the  $V_{CCINT}$  profile shown. If this is not the case,  $t_{CONFIG}$  stretches out until all  $V_{CCIO}$  banks are powered.

 After SRAM configuration, all registers in the device are cleared and released into user function before the I/O tri-states are released. To release clears after the tri-states are released, use the DEV\_CLRn pin option. To hold the tri-states beyond the power-up configuration time, use the DEV\_OE pin option.

## Document Revision History

Table 4-1 lists the revision history for this chapter.

**Table 4-1. Document Revision History**

Date	Version	Changes
December 2010	1.0	Initial release.

This chapter describes how to implement Altera® devices in multi-voltage systems without damaging the device or the system.

Technological advancements in deep submicron processes have lowered the supply voltage levels of semiconductor devices, creating a design environment where devices on a system board may potentially use many different supply voltages such as 5.0, 3.3, 2.5, 1.8, 1.5, and 1.2 V, which can ultimately lead to voltage conflicts.

To accommodate interfacing with a variety of devices on system boards, MAX® V devices have MultiVolt I/O interfaces that allow devices in a mixed-voltage design environment to communicate directly with MAX V devices. The MultiVolt interface separates the power supply voltage ( $V_{CCINT}$ ) from the output voltage ( $V_{CCIO}$ ), allowing MAX V devices to interface with other devices using a different voltage level on the same PCB. The 1.8-V input directly powers the core of the MAX V devices.

 For more information about hot socketing and power-on reset (POR), refer to the *Hot Socketing and Power-On Reset in MAX V Devices* chapter.

This chapter contains the following sections:

- “I/O Standards” on page 5–1
- “MultiVolt I/O Operation” on page 5–3
- “5.0-V Device Compatibility” on page 5–3
- “Recommended Operating Conditions for 5.0-V Compatibility” on page 5–7
- “Power-Up Sequencing” on page 5–8

## I/O Standards

The I/O buffer of MAX V devices is programmable and supports a wide range of I/O voltage standards. You can program each I/O bank in a MAX V device to comply with a different I/O standard. You can configure all I/O banks with the following standards:

- 3.3-V LVTTTL/LVCMOS
- 2.5-V LVTTTL/LVCMOS
- 1.8-V LVTTTL/LVCMOS
- 1.5-V LVCMOS
- 1.2-V LVCMOS (Not supported in Bank 1)
- Emulated LVDS output (LVDS\_E\_3R)
- Emulated RSDS output (RSDS\_E\_3R)

The Schmitt trigger input option is supported by the 3.3-V and 2.5-V I/O standards. The I/O Bank 3 also includes the 3.3-V PCI I/O standard interface capability on the 5M1270Z and 5M2210Z devices. Figure 5-1 shows the I/O standards supported by MAX V devices.

**Figure 5-1. I/O Standards Supported by MAX V Devices (Note 1), (2), (3), (4), (5)**

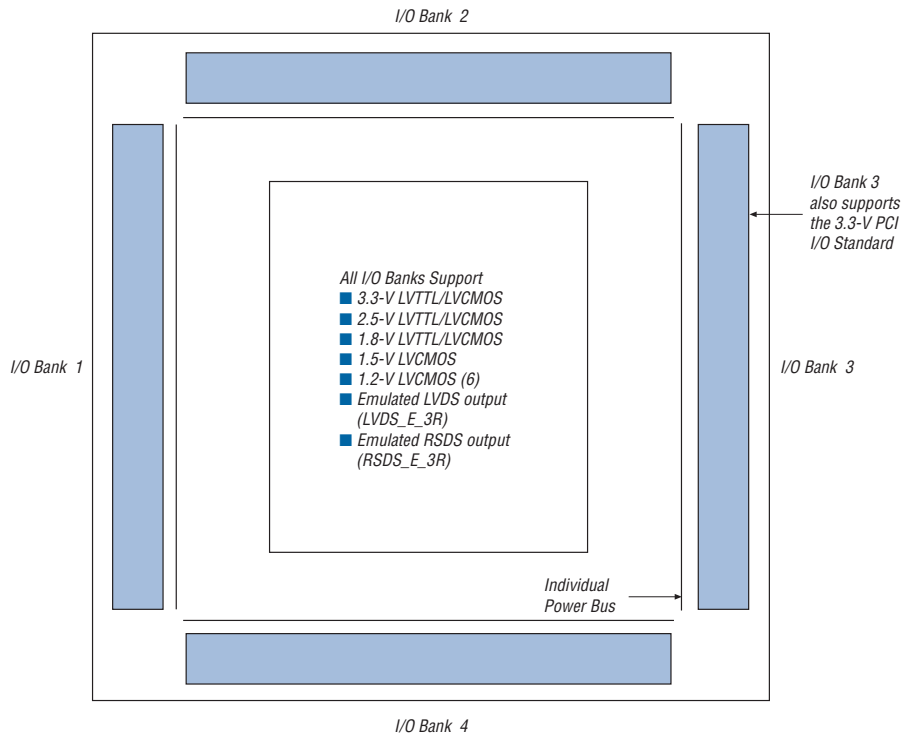

**Notes to Figure 5-1:**

- (1) Figure 5-1 is a top view of the silicon die.
- (2) Figure 5-1 is a graphical representation only. For the exact pin locations, refer to the pin list and the Quartus® II software.
- (3) 5M40Z, 5M80Z, 5M160Z, 5M240Z, and 5M570Z devices only have two I/O banks.
- (4) The 3.3-V PCI I/O standard is only supported in 5M1270Z and 5M2210Z devices.
- (5) The Schmitt trigger input option for 3.3-V and 2.5-V I/O standards is supported for all I/O pins.
- (6) This I/O standard is not supported in Bank 1.

## MultiVolt I/O Operation

MAX V devices allow the device core and I/O blocks to be powered-up with separate supply voltages. The  $V_{CCINT}$  pins supply power to the device core and the  $V_{CCIO}$  pins supply power to the device I/O buffers. The  $V_{CCINT}$  pins are powered-up with 1.8 V for MAX V devices. All the  $V_{CCIO}$  pins for a given I/O bank that have MultiVolt capability must be supplied from the same voltage level (for example, 5.0, 3.3, 2.5, 1.8, 1.5, or 1.2 V). Figure 5-2 shows how to implement a multiple-voltage system for MAX V devices.

**Figure 5-2. Implementing a Multi-Voltage System with a MAX V Device (Note 1), (2)**

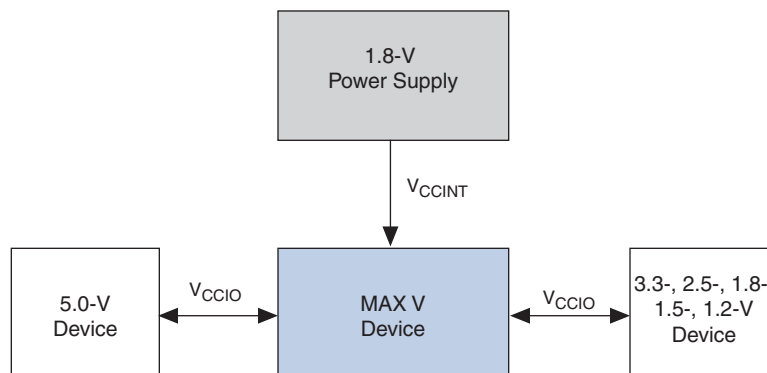

**Notes to Figure 5-2:**

- (1) MAX V devices can drive a 5.0-V transistor-to-transistor logic (TTL) input when  $V_{CCIO} = 3.3$  V. To drive a 5.0-V CMOS, you must have an open-drain setting with an internal I/O clamp diode and external resistor.
- (2) MAX V devices can be 5.0-V tolerant with the use of an external resistor and the internal I/O clamp diode on 5M1270Z and 5M2210Z devices.

## 5.0-V Device Compatibility

A MAX V device can drive a 5.0-V TTL device by connecting the  $V_{CCIO}$  pins of the MAX V device to 3.3 V. This is possible because the output high voltage ( $V_{OH}$ ) of a 3.3-V interface meets the minimum high-level voltage of 2.4 V of a 5.0-V TTL device.

A MAX V device may not correctly interoperate with a 5.0-V CMOS device if the output of the MAX V device is connected directly to the input of the 5.0-V CMOS device. If the MAX V device's  $V_{OUT}$  is greater than  $V_{CCIO}$ , the PMOS pull-up transistor still conducts if the pin is driving high, preventing an external pull-up resistor from pulling the signal to 5.0 V. To make MAX V device outputs compatible with 5.0-V CMOS devices, configure the output pins as open-drain pins with the I/O clamp diode enabled and use an external pull-up resistor.

Figure 5-3 shows MAX V device compatibility with 5.0-V CMOS devices.

**Figure 5-3. MAX V Device Compatibility with 5.0-V CMOS Devices**

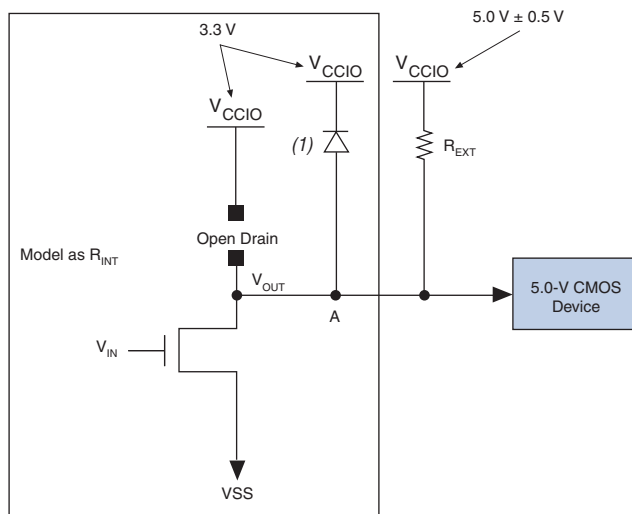

**Note to Figure 5-3:**

(1) This diode is only active after power-up. MAX V devices require an external diode if driven by 5.0 V before power-up.

The open-drain pin never drives high, only low or tri-state. When the open-drain pin is active, it drives low. When the open-drain pin is inactive, the pin is tri-stated and the trace pulls up to 5.0 V by the external resistor. The purpose of enabling the I/O clamp diode is to protect the MAX V device's I/O pins. The 3.3-V  $V_{CCIO}$  supplied to the I/O clamp diodes causes the voltage at point A to clamp at 4.0 V, which meets the MAX V device's reliability limits when the trace voltage exceeds 4.0 V. The device operates successfully because a 5.0-V input is within its input specification.



The I/O clamp diode is only supported in the 5M1270Z and 5M2210Z devices' I/O Bank 3. You must have an external protection diode for the other I/O banks in the 5M1270Z and 5M2210Z devices and all the I/O pins in the 5M40Z, 5M80Z, 5M160Z, 5M240Z, and 5M570Z devices.

The pull-up resistor value must be small enough for a sufficient signal rise time, but large enough so that it does not violate the  $I_{OL}$  (output low) specification of the MAX V devices.

The maximum MAX V device  $I_{OL}$  depends on the programmable drive strength of the I/O output. Table 5-1 lists the programmable drive strength settings that are available for the 3.3-V LVTTTL/LVCMOS I/O standard for MAX V devices. The Quartus II software uses the maximum current strength as the default setting. The PCI I/O standard is always set to 20 mA with no alternate setting.

**Table 5-1. 3.3-V LVTTTL/LVCMOS Programmable Drive Strength (Part 1 of 2)**

I/O Standard	$I_{OH}/I_{OL}$ Current Strength Setting (mA)
3.3-V LVTTTL	16
	8

**Table 5-1. 3.3-V LVTTTL/LVCMOS Programmable Drive Strength (Part 2 of 2)**

I/O Standard	I <sub>OH</sub> /I <sub>OL</sub> Current Strength Setting (mA)
3.3-V LVCMOS	8
	4

To compute the required value of R<sub>EXT</sub>, first calculate the model of the open-drain transistors on the MAX V device. You can model this output resistor (R<sub>EXT</sub>) by dividing V<sub>OL</sub> by I<sub>OL</sub> (R<sub>EXT</sub> = V<sub>OL</sub>/I<sub>OL</sub>). Table 5-2 lists the maximum V<sub>OL</sub> for the 3.3-V LVTTTL/LVCMOS I/O standard for MAX V devices.

 For more information about I/O standard specifications, refer to the *DC and Switching Characteristics for MAX V Devices* chapter.

**Table 5-2. 3.3-V LVTTTL/LVCMOS Maximum V<sub>OL</sub>**

I/O Standard	Voltage (V)
3.3-V LVTTTL	0.45
3.3-V LVCMOS	0.20

Select R<sub>EXT</sub> so that the MAX V device's I<sub>OL</sub> specification is not violated. You can compute the required pull-up resistor value of R<sub>EXT</sub> by using the equation: R<sub>EXT</sub> = (V<sub>CC</sub>/I<sub>OL</sub>) - R<sub>INT</sub>. For example, if an I/O pin is configured as a 3.3-V LVTTTL with a 16 mA drive strength, given that the maximum power supply (V<sub>CC</sub>) is 5.5 V, you can calculate the value of R<sub>EXT</sub> as follows:

**Equation 5-1.**

$$R_{EXT} = \frac{(5.5 \text{ V} - 0.45 \text{ V})}{16 \text{ mA}} = 315.6 \Omega$$

This resistor value computation assumes worst-case conditions. You can adjust the R<sub>EXT</sub> value according to the device configuration drive strength. Additionally, if your system does not see a wide variation in voltage-supply levels, you can adjust these calculations accordingly.

Because MAX V devices are 3.3-V, 32-bit, 66-MHz PCI compliant, the input circuitry accepts a maximum high-level input voltage (V<sub>IH</sub>) of 4.0 V. To drive a MAX V device with a 5.0-V device, you must connect a resistor (R<sub>2</sub>) between the MAX V device and the 5.0-V device.

Figure 5-4 shows how to drive a MAX V PCI-compliant device with a 5.0-V device.

**Figure 5-4. Driving a MAX V PCI-Compliant Device with a 5.0-V Device**

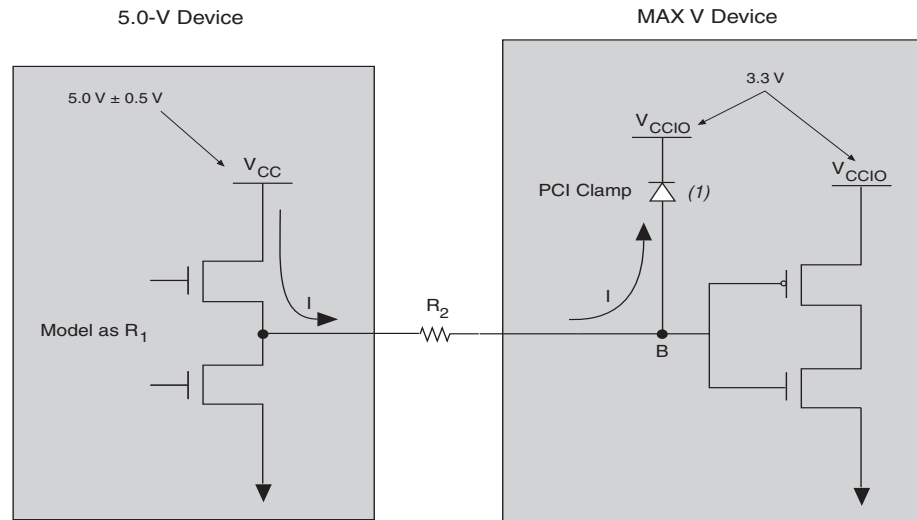

**Note to Figure 5-4:**

(1) This diode is only active after power-up. MAX V devices require an external diode if driven by 5.0 V before power-up.

If  $V_{CCIO}$  for the MAX V devices is 3.3 V and you enabled the I/O clamp diode, the voltage at point B in Figure 5-4 is 4.0 V, which meets the MAX V devices reliability limits when the trace voltage exceeds 4.0 V. To limit large current draw from the 5.0-V device,  $R_2$  must be small enough for a fast signal rise time and large enough so that it does not violate the high-level output current ( $I_{OH}$ ) specifications of the devices driving the trace.

To compute the required value of  $R_2$ , first calculate the model of the pull-up transistors on the 5.0-V device. You can model this output resistor ( $R_1$ ) by dividing the 5.0-V device supply voltage ( $V_{CC}$ ) by  $I_{OH}$ :  $R_1 = V_{CC}/I_{OH}$ .

Figure 5-5 shows an example of typical output drive characteristics of a 5.0 V device.

**Figure 5-5. Output Drive Characteristics of a 5.0-V Device**

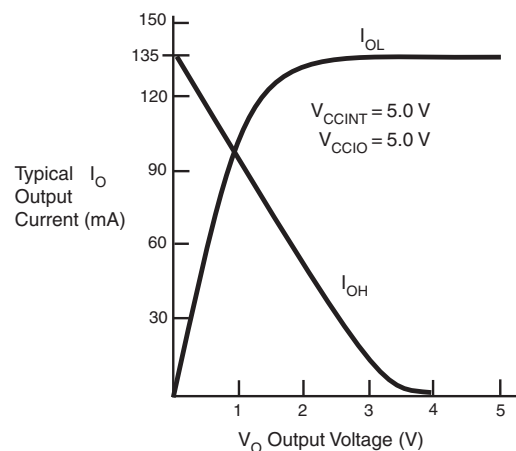

As shown in Figure 5-5,  $R_1 = 5.0 \text{ V} / 135 \text{ mA}$ .

The values usually shown in the data sheets reflect typical operating conditions. Subtract 20% from the data sheet value for guard band. When you subtract the 20% from the previous example, the  $R_1$  value is 30.

Select  $R_2$  so that the MAX V device's  $I_{OH}$  specification is not violated. For example, if the above device has a maximum  $I_{OH}$  of 8 mA, given the I/O clamp diode,  $V_{IN} = V_{CCIO} + 0.7 \text{ V} = 3.7 \text{ V}$ . Given that the maximum supply load of a 5.0-V device ( $V_{CC}$ ) is 5.5 V, calculate value of  $R_2$  as follows:

**Equation 5-2.**

$$R_2 = \frac{(5.5 \text{ V} - 3.7 \text{ V}) - (8 \text{ mA} \times 30 \Omega)}{8 \text{ mA}} = 194 \Omega$$

This analysis assumes worst-case conditions. If your system does not see a wide variation in voltage-supply levels, you can adjust these calculations accordingly.

Because 5.0-V device tolerance in MAX V devices requires the use of the I/O clamp, and this clamp is activated only after power-up, 5.0-V signals may not be driven into the device until it is configured. The I/O clamp diode is only supported in the 5M1270Z and 5M2210Z devices' I/O Bank 3. You must have an external protection diode for the other I/O banks for the 5M1270Z and 5M2210Z devices and all the I/O pins in the 5M40Z, 5M80Z, 5M160Z, 5M240Z, and 5M570Z devices.

## Recommended Operating Conditions for 5.0-V Compatibility

As mentioned earlier, a 5.0-V tolerance can be supported with the I/O clamp diode enabled with external series/pull-up resistance. To guarantee long term reliability of the device's I/O buffer, there are restrictions on the signal duty cycle that drive the MAX V I/O, which is based on the maximum clamp current. Table 5-3 lists the maximum signal duty cycle for the 3.3-V  $V_{CCIO}$  given a PCI clamp current-handling capability.

**Table 5-3. Maximum Signal Duty Cycle**

$V_{IN}$ (V) (1)	$I_{CH}$ (mA) (2)	Max Duty Cycle (%)
4.0	5.00	100
4.1	11.67	90
4.2	18.33	50
4.3	25.00	30
4.4	31.67	17
4.5	38.33	10
4.6	45.00	5

**Notes to Table 5-3:**

- (1)  $V_{IN}$  is the voltage at the package pin.
- (2) The  $I_{CH}$  is calculated with a 3.3-V  $V_{CCIO}$ . A higher  $V_{CCIO}$  value will have a lower  $I_{CH}$  value with the same  $V_{IN}$ .

 For signals with a duty cycle greater than 30% on MAX V input pins, Altera recommends using a  $V_{CCIO}$  voltage of 3.0 V to guarantee long-term I/O reliability. For signals with a duty cycle less than 30%, the  $V_{CCIO}$  voltage can be 3.3 V.

## Power-Up Sequencing

MAX V devices are designed to operate in multi-voltage environments where it may be difficult to control power sequencing. Therefore, MAX V devices are designed to tolerate any possible power-up sequence. Either  $V_{CCINT}$  or  $V_{CCIO}$  can initially supply power to the device and 3.3-, 2.5-, 1.8-, 1.5-, or 1.2-V input signals can drive the devices without special precautions before  $V_{CCINT}$  or  $V_{CCIO}$  is applied. MAX V devices can operate with a  $V_{CCIO}$  voltage level that is higher than the  $V_{CCINT}$  level.

When  $V_{CCIO}$  and  $V_{CCINT}$  are supplied from different power sources to a MAX V device, a delay between  $V_{CCIO}$  and  $V_{CCINT}$  may occur. Normal operation does not occur until both power supplies are in their recommended operating range. When  $V_{CCINT}$  is powered-up, the IEEE Std. 1149.1 JTAG circuitry is active. If TMS and TCK are connected to  $V_{CCIO}$  and  $V_{CCIO}$  is not powered-up, the JTAG signals are left floating. Thus, any transition on TCK can cause the state machine to transition to an unknown JTAG state, leading to incorrect operation when  $V_{CCIO}$  is finally powered-up. To disable the JTAG state during the power-up sequence, pull TCK low to ensure that an inadvertent rising edge does not occur on TCK.

## Document Revision History

Table 5-4 lists the revision history for this chapter.

**Table 5-4. Document Revision History**

Date	Version	Changes
June 2017	2017.06.16	Added note to state that 1.2-V LVCMOS is not supported in Bank 1.
December 2010	1.0	Initial release.

This chapter describes the IEEE Standard 1149.1 JTAG BST circuitry that is supported in MAX<sup>®</sup> V devices and how you can enable concurrent in-system programming of multiple devices in a minimum time with the IEEE Standard 1532 in-system programmability (ISP). This chapter also describes the programming sequence, types of programming with the Quartus<sup>®</sup> II software or external hardware, and design security.

This chapter includes the following sections:

- “IEEE Std. 1149.1 Boundary-Scan Support” on page 6–1
- “In-System Programmability” on page 6–5

### IEEE Std. 1149.1 Boundary-Scan Support

All MAX V devices provide JTAG BST circuitry that complies with the IEEE Std. 1149.1-2001 specification. You can only perform JTAG boundary-scan testing after you have fully powered the  $V_{CCINT}$  and all  $V_{CCIO}$  banks and a certain amount of configuration time ( $t_{CONFIG}$ ) have passed. For in-system programming, MAX V devices can use the JTAG port with either the Quartus II software or hardware with Programmer Object File (.pof), Jam<sup>™</sup> Standard Test and Programming Language (STAPL) Format File (.jam), or Jam Byte Code Files (.jbc).

JTAG pins support 1.5-V, 1.8-V, 2.5-V, and 3.3-V I/O standards. The  $V_{CCIO}$  of the bank where it is located determines the supported voltage level and standard. The dedicated JTAG pins reside in Bank 1 of all MAX V devices.

Table 6–1 lists the JTAG instructions supported in MAX V devices.

**Table 6–1. JTAG Instructions for MAX V Devices (Part 1 of 2)**

JTAG Instruction	Instruction Code	Description
SAMPLE/PRELOAD	00 0000 0101	Allows you to capture and examine a snapshot of signals at the device pins if the device is operating in normal mode. Permits an initial data pattern to be an output at the device pins.
EXTEST (1)	00 0000 1111	Allows you to test the external circuitry and board-level interconnects by forcing a test pattern at the output pins and capturing test results at the input pins.
BYPASS	11 1111 1111	Places the 1-bit bypass register between the TDI and TDO pins, which allows the boundary-scan test (BST) data to pass synchronously through target devices to adjacent devices during normal device operation.
USERCODE	00 0000 0111	Selects the 32-bit USERCODE register and places it between the TDI and TDO pins, allowing you to shift the USERCODE register out of the TDO pin serially. If you do not specify the USERCODE in the Quartus II software, the 32-bit USERCODE register defaults to all 1's.

© 2011 Altera Corporation. All rights reserved. ALTERA, ARRIA, CYCLONE, HARDCOPY, MAX, MEGACORE, NIOS, QUARTUS and STRATIX are Reg. U.S. Pat. & Tm. Off. and/or trademarks of Altera Corporation in the U.S. and other countries. All other trademarks and service marks are the property of their respective holders as described at [www.altera.com/common/legal.html](http://www.altera.com/common/legal.html). Altera warrants performance of its semiconductor products to current specifications in accordance with Altera's standard warranty, but reserves the right to make changes to any products and services at any time without notice. Altera assumes no responsibility or liability arising out of the application or use of any information, product, or service described herein except as expressly agreed to in writing by Altera. Altera customers are advised to obtain the latest version of device specifications before relying on any published information and before placing orders for products or services.

**Table 6-1. JTAG Instructions for MAX V Devices (Part 2 of 2)**

JTAG Instruction	Instruction Code	Description
IDCODE	00 0000 0110	Selects the IDCODE register and places it between the TDI and TDO pins, allowing you to shift the IDCODE register out of the TDO pin serially.
HIGHZ (1)	00 0000 1011	Places the 1-bit bypass register between the TDI and TDO pins, which allows the BST data to pass synchronously through target devices to adjacent devices if the device is operating in normal mode and tri-stating all the I/O pins.
CLAMP (1)	00 0000 1010	Places the 1-bit bypass register between the TDI and TDO pins, which allows the BST data to pass synchronously through target devices to adjacent devices during normal device operation and holding I/O pins to a state defined by the data in the boundary-scan register.
USER0	00 0000 1100	Allows you to define the scan chain between the TDI and TDO pins in the MAX V logic array. Use this instruction for custom logic and JTAG interfaces.
USER1	00 0000 1110	Allows you to define the scan chain between the TDI and TDO pins in the MAX V logic array. Use this instruction for custom logic and JTAG interfaces.
IEEE 1532 instructions	For the instruction codes of the IEEE 1532 instructions, refer to the <a href="#">IEEE 1532 BSDL Files</a> page of the Altera website.	IEEE 1532 in-system concurrent (ISC) instructions used if programming a MAX V device through the JTAG port.

**Note to Table 6-1:**

(1) HIGHZ, CLAMP, and EXTEST instructions do not disable weak pull-up resistors or bus hold features.



You must not issue unsupported JTAG instructions to the MAX V device because this may put the device into an unknown state, requiring a power cycle to recover device operation.

The MAX V device instruction register length is 10 bits and the USERCODE register length is 32 bits. Table 6-2 and Table 6-3 list the boundary-scan register length and device IDCODE information for MAX V devices.

**Table 6-2. Boundary-Scan Register Length for MAX V Devices**

Device	Boundary-Scan Register Length
5M40Z	240
5M80Z	240
5M160Z	240
5M240Z (1)	240
5M240Z (2)	480
5M570Z	480
5M1270Z (3)	636
5M1270Z (4)	816
5M2210Z	816

**Notes to Table 6-2:**

- (1) Not applicable to T144 package of the 5M240Z device.
- (2) Only applicable to T144 package of the 5M240Z device.
- (3) Not applicable to F324 package of the 5M1270Z device.
- (4) Only applicable to F324 package of the 5M1270Z device.

**Table 6-3. 32-Bit IDCODE for MAX V Devices**

Device	Binary IDCODE (32 Bits) (1)				HEX IDCODE
	Version (4 Bits)	Part Number	Manufacturer Identity (11 Bits)	LSB (1 Bit) (2)	
5M40Z	0000	0010 0000 1010 0101	000 0110 1110	1	0x020A50DD
5M80Z	0000	0010 0000 1010 0101	000 0110 1110	1	0x020A50DD
5M160Z	0000	0010 0000 1010 0101	000 0110 1110	1	0x020A50DD
5M240Z (3)	0000	0010 0000 1010 0101	000 0110 1110	1	0x020A50DD
5M240Z (4)	0000	0010 0000 1010 0110	000 0110 1110	1	0x020A60DD
5M570Z	0000	0010 0000 1010 0110	000 0110 1110	1	0x020A60DD
5M1270Z (5)	0000	0010 0000 1010 0011	000 0110 1110	1	0x020A30DD
5M1270Z (6)	0000	0010 0000 1010 0100	000 0110 1110	1	0x020A40DD
5M2210Z	0000	0010 0000 1010 0100	000 0110 1110	1	0x020A40DD

**Notes to Table 6-2:**

- (1) The MSB is on the left.
- (2) The LSB for IDCODE is always 1.
- (3) Not applicable to T144 package of the 5M240Z device.
- (4) Only applicable to T144 package of the 5M240Z device.
- (5) Not applicable to F324 package of the 5M1270Z device.
- (6) Only applicable to F324 package of the 5M1270Z device.

 For JTAG direct current (DC) characteristics, refer to the *DC and Switching Characteristics for MAX V Devices* chapter.

 For more information about JTAG BST, refer to the *JTAG Boundary-Scan Testing for MAX V Devices* chapter.

## JTAG Block

If you issue either the USER0 or USER1 instruction to the JTAG test access port (TAP) controller, the MAX V JTAG block feature allows you to access the JTAG TAP controller and state signals. The USER0 and USER1 instructions bring the JTAG boundary-scan chain (TDI) through the user logic instead of the boundary-scan cells (BSCs) of MAX V devices. Each USER instruction allows for one unique user-defined JTAG chain into the logic array.

### Parallel Flash Loader

MAX V devices have the ability to interface JTAG to non-JTAG devices and are suitable to use with the general flash memory devices that require programming during the in-circuit test. You can use the flash memory devices for FPGA configuration or be part of the system memory. In many cases, you can use the MAX V device as a bridge device that controls configuration between FPGA and flash devices. Unlike ISP-capable CPLDs, bulk flash devices do not have JTAG TAP pins or connections. For small flash devices, it is common to use the serial JTAG scan chain of a connected device to program the non-JTAG flash device but this is slow, inefficient, and impractical for large parallel flash devices. Using the MAX V JTAG block as a parallel flash loader (PFL) with the Quartus II software to program and verify flash contents provides a fast and cost-effective means of in-circuit programming during testing.

 For more information about PFL, refer to the *Parallel Flash Loader Megafunction User Guide*.

Figure 6-1 shows how you can use the MAX V JTAG block as a PFL.

Figure 6-1. PFL for MAX V Devices

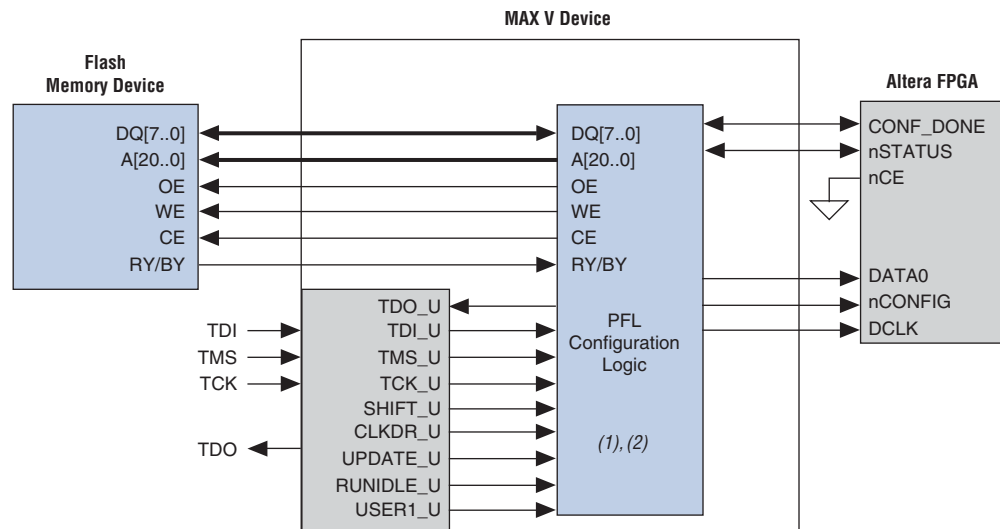

**Notes to Figure 6-1:**

- (1) This block is implemented in logic elements (LEs).
- (2) This function is supported in the Quartus II software.

## In-System Programmability

You can program MAX V devices in-system through the industry standard 4-pin IEEE Std. 1149.1 interface. ISP offers quick and efficient iterations during design development and debugging cycles. The flash-based SRAM configuration elements configure the logic, circuitry, and interconnects in the MAX V architecture. Each time the device is powered up, the configuration data is loaded into the SRAM elements. The process of loading the SRAM data is called configuration. The on-chip configuration flash memory (CFM) block stores the configuration data of the SRAM element. The CFM block stores the configuration pattern of your design in a reprogrammable flash array. During ISP, the MAX V JTAG and ISP circuitry programs the design pattern into the non-volatile flash array of the CFM block.

The MAX V JTAG and ISP controller internally generate the high programming voltages required to program the CFM cells, allowing in-system programming with any of the recommended operating external voltage supplies. You can configure the ISP anytime after you have fully powered  $V_{CCINT}$  and all  $V_{CCIO}$  banks, and the device has completed the configuration power-up time. By default, during in-system programming, the I/O pins are tri-stated and weakly pulled-up to  $V_{CCIO}$  banks to eliminate board conflicts. The in-system programming clamp and real-time ISP feature allow user control of the I/O state or behavior during ISP.

For more information, refer to [“In-System Programming Clamp”](#) on page 6-7 and [“Real-Time ISP”](#) on page 6-8.

These devices also offer an `ISP_DONE` bit that provides safe operation if in-system programming is interrupted. This `ISP_DONE` bit, which is the last bit programmed, prevents all I/O pins from driving until the bit is programmed.

## IEEE 1532 Support

The JTAG circuitry and ISP instruction set in MAX V devices are compliant to the IEEE-1532-2002 programming specification. This provides industry-standard hardware and software for in-system programming among multiple vendor programmable logic devices (PLDs) in a JTAG chain.

-  For more information about MAX V 1532 Boundary-Scan Description Language (.bsd) files, refer to the [IEEE 1532 BSDL Files](#) page of the Altera website.

## Jam Standard Test and Programming Language

You can use the Jam STAPL to program MAX V devices with in-circuit testers, PCs, or embedded processors. The Jam byte code is also supported for MAX V devices. These software programming protocols provide a compact embedded solution for programming MAX V devices.

-  For more information, refer to *AN 425: Using Command-Line Jam STAPL Solution for Device Programming*.

## Programming Sequence

During in-system programming, 1532 instructions, addresses, and data are shifted into the MAX V device through the TDI input pin. Data is shifted out through the TDO output pin and compared with the expected data.

To program a pattern into the device, follow these steps:

1. *Enter ISP*—The enter ISP stage ensures that the I/O pins transition smoothly from user mode to ISP mode.
2. *Check ID*—The silicon ID is checked before any Program or Verify process. The time required to read this silicon ID is relatively small compared to the overall programming time.
3. *Sector Erase*—Erasing the device in-system involves shifting in the instruction to erase the device and applying an erase pulse or pulses. The erase pulse is automatically generated internally by waiting in the run, test, or idle state for the specified erase pulse time of 500 ms for the CFM block and 500 ms for each sector of the user flash memory (UFM) block.
4. *Program*—Programming the device in-system involves shifting in the address, data, and program instruction and generating the program pulse to program the flash cells. The program pulse is automatically generated internally by waiting in the run/test/idle state for the specified program pulse time of 75  $\mu$ s. This process is repeated for each address in the CFM and UFM blocks.
5. *Verify*—Verifying a MAX V device in-system involves shifting in addresses, applying the verify instruction to generate the read pulse, and shifting out the data for comparison. This process is repeated for each CFM and UFM address.
6. *Exit ISP*—An exit ISP stage ensures that the I/O pins transition smoothly from ISP mode to user mode.

A stand-alone verification of a programmed pattern involves only steps 1, 2, 5, and 6. These steps are automatically executed by third-party programmers, the Quartus II software, or the Jam STAPL and Jam Byte-Code Players.

Table 6-4 lists the programming times for MAX V devices with in-circuit testers to execute the algorithm vectors in hardware. Because of data processing and data transfer limitations, software-based programming tools used with download cables are slightly slower.

**Table 6-4. Family Programming Times for MAX V Devices**

Description	5M40Z/ 5M80Z/ 5M160Z/ 5M240Z (1)	5M240Z (2)	5M570Z	5M1270Z (3)	5M1270Z (4)	5M2210Z	Unit
Erase + Program (1 MHz)	1.72	2.16	2.16	2.90	3.92	3.92	sec
Erase + Program (10 MHz)	1.65	1.99	1.99	2.58	3.40	3.40	sec
Verify (1 MHz)	0.09	0.17	0.17	0.30	0.49	0.49	sec
Verify (10 MHz)	0.01	0.02	0.02	0.03	0.05	0.05	sec
Complete Program Cycle (1 MHz)	1.81	2.33	2.33	3.20	4.41	4.41	sec
Complete Program Cycle (10 MHz)	1.66	2.01	2.01	2.61	3.45	3.45	sec

**Notes to Table 6-4:**

- (1) Not applicable to T144 package of the 5M240Z device.
- (2) Only applicable to T144 package of the 5M240Z device.
- (3) Not applicable to F324 package of the 5M1270Z device.
- (4) Only applicable to F324 package of the 5M1270Z device.

## User Flash Memory Programming

The Quartus II software (with the use of .pof, .jam, or .jbc files) supports programming of the UFM block independent of the logic array design pattern stored in the CFM block. This allows updating or reading UFM contents through ISP without altering the current logic array design, or vice versa. By default, these programming files and methods program the entire flash memory contents, which includes the CFM block and UFM contents. The stand-alone embedded Jam STAPL Player and Jam Byte-Code Player provide action commands for programming or reading the entire flash memory (UFM and CFM together) or each independently.



For more information, refer to *AN 425: Using the Command-Line Jam STAPL Solution for Device Programming*.

## In-System Programming Clamp

By default, the IEEE 1532 instruction used for entering ISP automatically tri-states all I/O pins with weak pull-up resistors for the duration of the ISP sequence. However, some systems may require certain pins on MAX V devices to maintain a specific DC logic level during an in-field update. For these systems, you can use the optional in-system programming clamp instruction in the MAX V circuitry to control I/O

behavior during the ISP sequence. The in-system programming clamp instruction allows the device to sample and sustain the value on an output pin (an input pin remains tri-stated if sampled) or to set a logic high, logic low, or tri-state value explicitly on any pin. Setting these options is controlled on an individual pin basis with the Quartus II software.

 For more information, refer to [AN 630: Real-Time ISP and ISP Clamp for Altera CPLDs](#).

## Real-Time ISP

For systems that require more than the DC logic level control of I/O pins, the real-time ISP feature allows you to update the CFM block with a new design image, while the current design continues to operate in the SRAM logic array and I/O pins. A new programming file is updated into the MAX V device without halting the original operation of your design, saving down-time costs for remote or field upgrades. The updated CFM block configures the new design into the SRAM after the next power cycle. You can execute an immediate SRAM configuration without a power cycle with a specific sequence of ISP commands. The SRAM configuration without a power cycle takes a specific amount of time ( $t_{\text{CONFIG}}$ ). During this time, the I/O pins are tri-stated and weakly pulled-up to  $V_{\text{CCIO}}$ .

## Design Security

All MAX V devices contain a programmable security bit that controls access to the data programmed into the CFM block. If this bit is programmed, you cannot copy or retrieve the design programming information stored in the CFM block. This feature provides a high-level design security because programmed data within flash memory cells is invisible. You can only reset the security bit that controls this function and other programmed data if the device is erased. The SRAM is also invisible and cannot be accessed regardless of the security bit setting. The security bit does not protect the UFM block data, and the UFM is accessible through JTAG or logic array connections.

## Programming with External Hardware

You can program MAX V devices by downloading the information through in-circuit testers, embedded processors, the Altera® ByteBlaster™ II, EthernetBlaster II, EthernetBlaster, and USB-Blaster™ cables. You need to power up these cable's  $V_{\text{CC(TRGT)}}$  with  $V_{\text{CCIO}}$  of Bank 1.

 For more information about the respective cables, refer to the [Cable & Adapter Drivers Information](#) page.

BP Microsystems, System General, and other programming hardware manufacturers provide programming support for Altera devices. For device support information, refer to their websites.

## Document Revision History

Table 6-5 lists the revision history for this chapter.

**Table 6-5. Document Revision History**

Date	Version	Changes
May 2011	1.1	Updated "Programming with External Hardware" section.
December 2010	1.0	Initial release.



This chapter provides guidelines for user flash memory (UFM) applications by describing the features and functionality of the MAX<sup>®</sup> V UFM block and the Quartus<sup>®</sup> II ALTUFM megafunction.

Altera<sup>®</sup> MAX V devices feature a UFM block that can be used for storing non-volatile information up to 8 Kbits, similar to a serial EEPROM. The UFM provides an ideal storage solution that supports all protocols (serial peripheral interface (SPI), parallel, and other protocols) for interfacing through bridging logic designed into the MAX V logic array.

This chapter contains the following sections:

- “UFM Array Description” on page 7-1
- “UFM Functional Description” on page 7-3
- “UFM Operating Modes” on page 7-8
- “Programming and Reading the UFM with JTAG” on page 7-12
- “Software Support for UFM Block” on page 7-13
- “Creating Memory Content File” on page 7-39
- “Simulation Parameters” on page 7-43

## UFM Array Description

Each UFM array is organized as two separate sectors with 4,096 bits per sector. Each sector can be erased independently. Table 7-1 lists the dimensions of the UFM array.

**Table 7-1. UFM Array Size**

Device	Total Bits	Sectors	Address Bits	Data Width
5M40Z	8,192	2 (4,096 bits per sector)	9	16
5M80Z	8,192	2 (4,096 bits per sector)	9	16
5M160Z	8,192	2 (4,096 bits per sector)	9	16
5M240Z	8,192	2 (4,096 bits per sector)	9	16
5M570Z	8,192	2 (4,096 bits per sector)	9	16
5M1270Z	8,192	2 (4,096 bits per sector)	9	16
5M2210Z	8,192	2 (4,096 bits per sector)	9	16

© 2014 Altera Corporation. All rights reserved. ALTERA, ARRIA, CYCLONE, HARDCOPY, MAX, MEGACORE, NIOS, QUARTUS and STRATIX are Reg. U.S. Pat. & Tm. Off. and/or trademarks of Altera Corporation in the U.S. and other countries. All other trademarks and service marks are the property of their respective holders as described at [www.altera.com/common/legal.html](http://www.altera.com/common/legal.html). Altera warrants performance of its semiconductor products to current specifications in accordance with Altera’s standard warranty, but reserves the right to make changes to any products and services at any time without notice. Altera assumes no responsibility or liability arising out of the application or use of any information, product, or service described herein except as expressly agreed to in writing by Altera. Altera customers are advised to obtain the latest version of device specifications before relying on any published information and before placing orders for products or services.

## Memory Organization Map

Table 7-2 lists the memory organization for the MAX V UFM block. There are 512 locations with 9 bits addressing a range of 000h to 1FFh. Each location stores 16-bit wide data. The MSB of the address register indicates the sector in operation.

**Table 7-2. Memory Organization**

Sector	Address Range	
1	100h	1FFh
0	000h	0FFh

## Using and Accessing UFM Storage

You can use the UFM to store data of different memory sizes and data widths. Even though the UFM storage width is 16 bits, you can implement different data widths or a serial interface with the ALTUFM megafunction. Table 7-3 lists the different data widths available for the three types of interfaces supported in the Quartus II software, as well as no interface.

**Table 7-3. Data Widths for Logic Array Interfaces**

Logic Array Interfaces	Data Widths (Bits)	Interface Types
I <sup>2</sup> C	8	Serial
SPI	8 or 16	Serial
Parallel	Options of 3 to 16	Parallel
None	16	Serial

For more details about the logic array interface options in the ALTUFM megafunction, refer to “[Software Support for UFM Block](#)” on page 7-13.



The UFM block is accessible through the logic array interface and the JTAG interface. However, the UFM logic array interface does not have access to the configuration flash memory (CFM) block.

## UFM Functional Description

Figure 7-1 is the block diagram of the MAX V UFM block and the interface signals.

Figure 7-1. UFM Block and Interface Signals

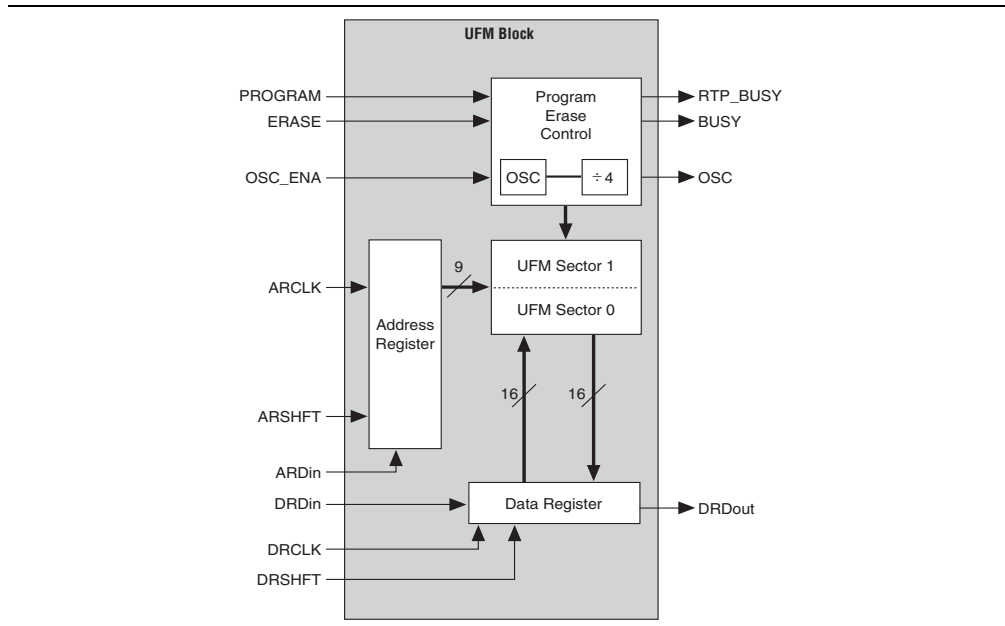



Table 7-4 lists the MAX V UFM block input and output interface signals.

Table 7-4. UFM Interface Signals (Part 1 of 2)

Port Name	Port Type	Description
DRDin	Input	Serial input to the data register. It is used to enter a data word when writing to the UFM. The data register is 16 bits wide and data is shifted serially from the LSB to the MSB with each DRCLK. This port is required for writing, but unused if the UFM is in read-only mode.
DRCLK	Input	Clock input that controls the data register. It is required and takes control when data is shifted from DRDin to DRDout or loaded in parallel from the flash memory. The maximum frequency for DRCLK is 10 MHz.
DRSHFT	Input	Signal that determines whether to shift the data register or load it on a DRCLK edge. A high value shifts the data from DRDin into the LSB of the data register and from the MSB of the data register out to DRDout. A low value loads the value of the current address in the flash memory to the data register.
ARDin	Input	Serial input to the address register. It is used to enter the address of a memory location to read, program, or erase. The address register is 9 bits wide for the UFM size of 8,192 bits.
ARCLK	Input	Clock input that controls the address register. It is required when shifting the address data from ARDin into the address register or during the increment stage. The maximum frequency for ARCLK is 10 MHz.
ARSHFT	Input	Signal that determines whether to shift the address register or increment it on an ARCLK edge. A high value shifts the data from ARDin serially into the address register. A low value increments the current address by 1. The address register rolls over to 0 when the address space is at the maximum.

**Table 7-4. UFM Interface Signals (Part 2 of 2)**

Port Name	Port Type	Description
PROGRAM	Input	Signal that initiates a program sequence. On the rising edge, the data in the data register is written to the address pointed to by the address register. The <code>BUSY</code> signal asserts until the program sequence is completed.
ERASE	Input	Signal that initiates an erase sequence. On a rising edge, the memory sector indicated by the MSB of the address register is erased. The <code>BUSY</code> signal asserts until the erase sequence is completed.
OSC_ENA	Input	This signal turns on the internal oscillator in the UFM block. It is required when the <code>OSC</code> output is used, but optional otherwise. If <code>OSC_ENA</code> is driven high, the internal oscillator is enabled and the <code>OSC</code> output will toggle. If <code>OSC_ENA</code> is driven low, the internal oscillator is disabled and the <code>OSC</code> output drives constant high.
DRDout	Output	Serial output of the data register. Each time the <code>DRCLK</code> signal is applied, a new value is available. The <code>DRDout</code> data depends on the <code>DRSHFT</code> signal. When the <code>DRSHFT</code> signal is high, <code>DRDout</code> contains the new value that is shifted into the MSB of the data register. If <code>DRSHFT</code> is low, <code>DRDout</code> contains the MSB of the memory location read into the data register.
BUSY	Output	Signal that indicates when the memory is <code>BUSY</code> performing a <code>PROGRAM</code> or <code>ERASE</code> instruction. When it is high, the address and data register should not be clocked. The new <code>PROGRAM</code> or <code>ERASE</code> instruction is not executed until the <code>BUSY</code> signal is deasserted.
OSC	Output	Output of the internal oscillator. It can be used to generate a clock to control user logic with the UFM. It requires an <code>OSC_ENA</code> input to produce an output.
RTP_BUSY	Output	This output signal is optional and only needed if the real-time ISP feature is used. The signal is asserted high during real-time ISP and stays in the <code>RUN_STATE</code> for 500 ms before initiating real-time ISP to allow for the final read/erase/write operation. No read, write, erase, or address and data shift operations are allowed to be issued after the <code>RTP_BUSY</code> signal goes high. The data and address registers do not retain the contents of the last read or write operation for the UFM block during real-time ISP.

 For more information about the interaction between the UFM block and the logic array of MAX V devices, refer to the [MAX V Device Architecture](#) chapter.

## UFM Address Register

The MAX V UFM block is organized as a  $512 \times 16$  memory. Because the UFM block is organized into two sectors, the MSB of the address indicates the sector that is used; 0 is for sector 0 (UFM0) while 1 is for sector 1 (UFM1). An ERASE instruction erases the content of the specific sector that is indicated by the MSB of the address register.

Figure 7-2 shows the selection of the UFM sector using the MSB of the address register.

For more information about the erase mode, refer to “Erase” on page 7-11.

**Figure 7-2. Selection of the UFM Sector Using the MSB of the Address Register**

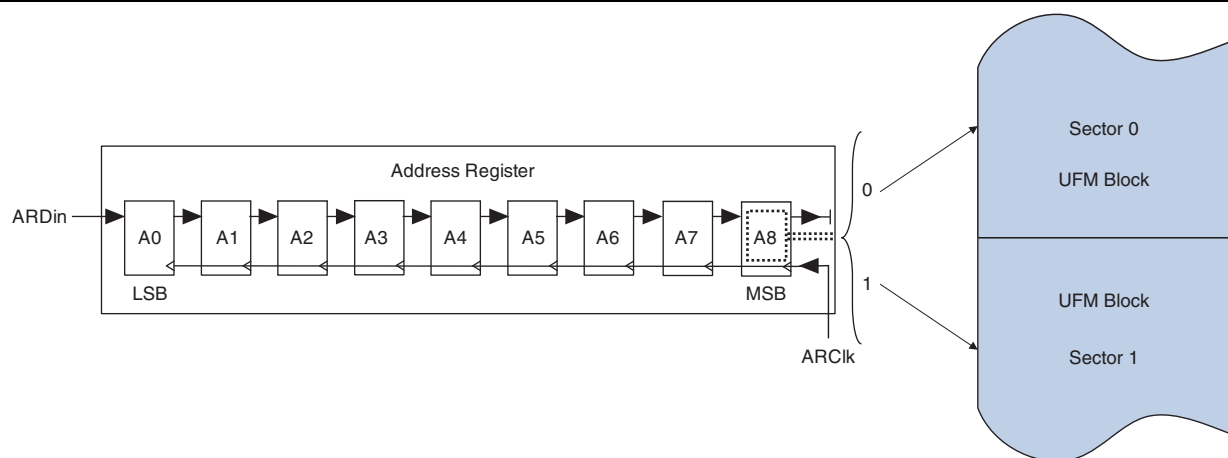

Three control signals exist for the address register: ARSHFT, ARCLK, and ARDin. ARSHFT is used as both a shift-enable control signal and an auto-increment signal. If the ARSHFT signal is high, a rising edge on ARCLK loads address data serially from the ARDin port and moves data serially through the register. A clock edge with the ARSHFT signal low increments the address register by 1. This implements an auto-increment of the address to allow data streaming. When a program, read, or erase sequence is executing, the address that is in the address register becomes the active UFM location.

## UFM Data Register

The UFM data register is 16 bits wide with four control signals: *DRSHFT*, *DRCLK*, *DRDin*, and *DRDout*. *DRSHFT* distinguishes between clock edges that move data serially from *DRDin* to *DRDout* and clock edges that latch parallel data from the UFM sectors. If the *DRSHFT* signal is high, a clock edge moves data serially through the registers from *DRDin* to *DRDout*. If the *DRSHFT* signal is low, a clock edge captures data from the UFM sector pointed by the address register in parallel. The MSB is the first bit that is seen at *DRDout*. The data register *DRSHFT* signal is also used to enable the UFM for reading data. When the *DRSHFT* signal is low, the UFM latches data into the data register. [Figure 7-3](#) shows the UFM data register.

**Figure 7-3. UFM Data Register**

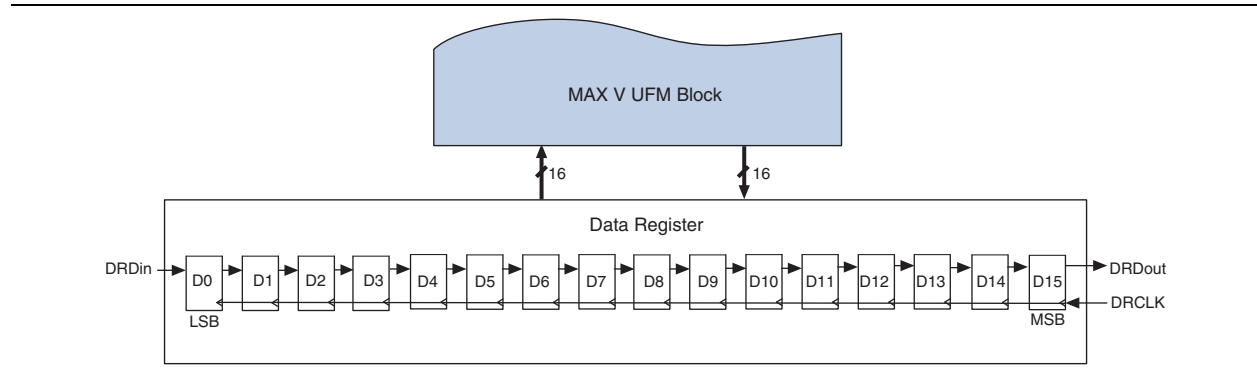

## UFM Program/Erase Control Block

The UFM program/erase control block is used to generate all the control signals necessary to program and erase the UFM block independently. This block reduces the number of logic elements (LEs) necessary to implement a UFM controller in the logic array. It also guarantees correct timing of the control signals to the UFM. A rising edge on either *PROGRAM* or *ERASE* signal causes this control signal block to activate and begin sequencing through the program or erase cycle. At this point, for a program instruction, the data currently in the data register is written to the address pointed to by the address register.

Only sector erase is supported by the UFM. When an *ERASE* command is executed, this control block erases the sector whose address is stored in the address register. When the **PROGRAM** or **ERASE** command first activates the program/erase control block, the *BUSY* signal will be driven high to indicate an operation in progress in the UFM. After the program or erase algorithm is completed, the *BUSY* signal is forced low.

## Oscillator

OSC\_ENA, one of the input signals in the UFM block, is used to enable the oscillator signal to output through the OSC output port. You can use this OSC output port to connect with the interface logic in the logic array. It can be routed through the logic array and fed back as an input clock for the address register (ARCLK) and the data register (DRCLK). The output frequency of the OSC port is one-fourth that of the oscillator frequency. As a result, the frequency range of the OSC port is 3.9 to 5.3 MHz. The maximum clock frequency accepted by ARCLK and DRCLK is 10 MHz and the duty cycle accepted by the DRCLK and ARCLK input ports is approximately 45% to 50%.

When the OSC\_ENA input signal is asserted, the oscillator is enabled and the output is routed to the logic array through the OSC output. When the OSC\_ENA signal is set low, the OSC output drives constant high. The routing delay from the OSC port of the UFM block to OSC output pin depends on placement. You can analyze this delay using the TimeQuest timing analyzer.

The undivided internal oscillator, which is not accessible, operates in a frequency range from 15.6 to 21.2 MHz. The internal oscillator is enabled during power-up, in-system programming, and real-time ISP. At all other times, the oscillator is not running unless the UFM is instantiated in the design and the OSC\_ENA port is asserted. To see how specific operating modes of the ALTUFM megafunction handle OSC\_ENA and the oscillator, refer to “[Software Support for UFM Block](#)” on page 7–13. For user-generated logic interfacing to the UFM, the oscillator must be enabled during program or erase operations, but not during read operations. The OSC\_ENA signal can be tied low if you are not issuing any **PROGRAM** or **ERASE** commands.

 During real-time ISP operation, the internal oscillator automatically enables and outputs through the OSC output port (if this port is instantiated) even though the OSC\_ENA signal is tied low. You can use the RTP\_BUSY signal to detect the beginning and ending of the real-time ISP operation for gated control of this self-enabled OSC output condition.

 The internal oscillator is not enabled all the time. The internal oscillator for the program or erase operation is only activated when the flash memory block is being programmed or erased. During a read operation, the internal oscillator is activated whenever the flash memory block is reading data.

### Instantiating the Oscillator without the UFM

You can use the MAX II/MAX V Oscillator megafunction selection in the MegaWizard™ Plug-In Manager to instantiate the UFM oscillator if you intend to use this signal without using the UFM memory block. [Figure 7–4](#) shows the ALTUFM\_OSC megafunction instantiation in the Quartus II software.

**Figure 7–4. The Quartus II ALTUFM\_OSC Megafunction**

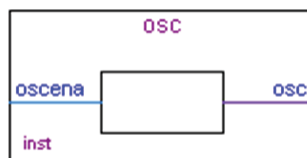

This megafunction is in the I/O folder on page 2a of the MegaWizard Plug-In Manager. On page 3 of the MAX II/MAX V Oscillator megafunction, you have an option to choose to simulate the OSC output port at its maximum or minimum frequency during the design simulation. The frequency chosen is only used as a timing parameter simulation and does not affect the real MAX V device OSC output frequency.

## UFM Operating Modes

There are three different modes for the UFM block:

- Read/Stream Read
- Program (Write)
- Erase

During program mode, address and data can be loaded concurrently. You can manipulate the UFM interface controls as necessary to implement the specific protocol provided the UFM timing specifications are met. [Figure 7-5](#) through [Figure 7-8](#) show the control waveforms for accessing UFM in three different modes. For program mode ([Figure 7-7](#)) and erase mode ([Figure 7-8](#)), the PROGRAM and ERASE signals can be asserted anytime after the address register and data register have been loaded. Do not assert the READ, PROGRAM, and ERASE signals or shift data and address into the UFM after entering the real-time ISP mode. You can use the RTP\_BUSY signal to detect the beginning and end of real-time ISP operation and generate control logic to stop all UFM port operations. This user-generated control logic is only necessary for the ALTUFM\_NONE megafunction, which provides no auto-generated logic. The other interfaces for the ALTUFM megafunction (ALTUFM\_PARALLEL, ALTUFM\_SPI, ALTUFM\_I2C) contain control logic to automatically monitor the RTP\_BUSY signal and will cease operations to the UFM when a real-time ISP operation is in progress.



You can program the UFM or CFM block independently without overwriting the other block, which is not programmed. The Quartus II programmer provides the options to program the UFM and CFM blocks individually or together (the entire MAX V Device).



For guidelines about using ISP and real-time ISP while using the UFM block within your design, refer to [AN 100: In-System Programmability Guidelines](#).



For a complete description of the device architecture, and for the specific values of the timing parameters listed in this chapter, refer to the [MAX V Device Architecture](#) chapter.

## Read/Stream Read

The three control signals, PROGRAM, ERASE, and BUSY are not required during a read or stream read operation. To perform a read operation, the address register must be loaded with the reference address where the data is or is going to be located in the UFM. The address register can be stopped from incrementing or shifting addresses from ARDin by stopping the ARCLK clock pulse. DRSHFT must be asserted low at the next rising edge of DRCLK to load the data from the UFM to the data register. To shift the bits from the register, 16 clock pulses must be provided to read 16-bit wide data. You can use DRCLK to control the read time or disable the data register by discontinuing the DRCLK clock pulse. Figure 7-5 shows the UFM control waveforms during read mode.

The UFM block can also perform a stream read operation, using the address increment feature to read continuously from the UFM. Stream read mode is started by loading the base address into the address register. DRSHFT must then be asserted low at the first rising edge of DRCLK to load data into the data register from the address pointed to by the address register. DRSHFT will then assert high to shift out the 16-bit wide data with the MSB out first. Figure 7-6 shows the UFM control waveforms during stream read mode.

**Figure 7-5. UFM Read Waveforms**

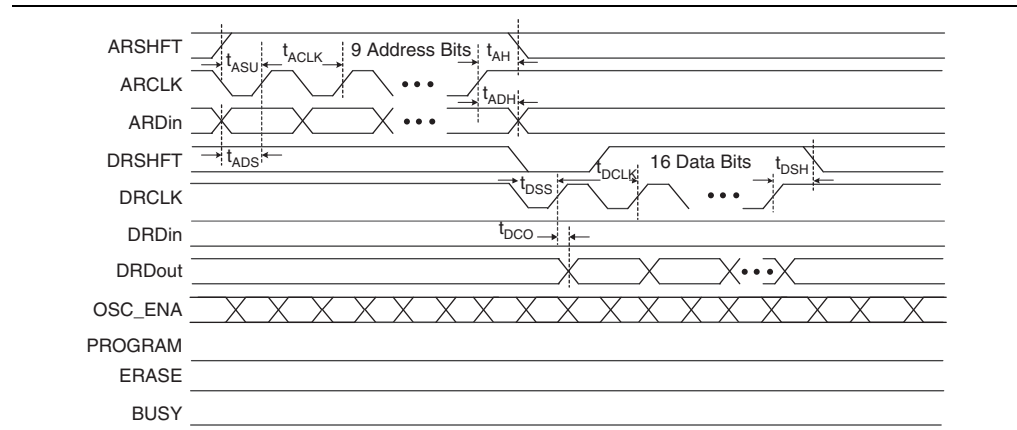

**Figure 7-6. UFM Stream Read Waveforms**

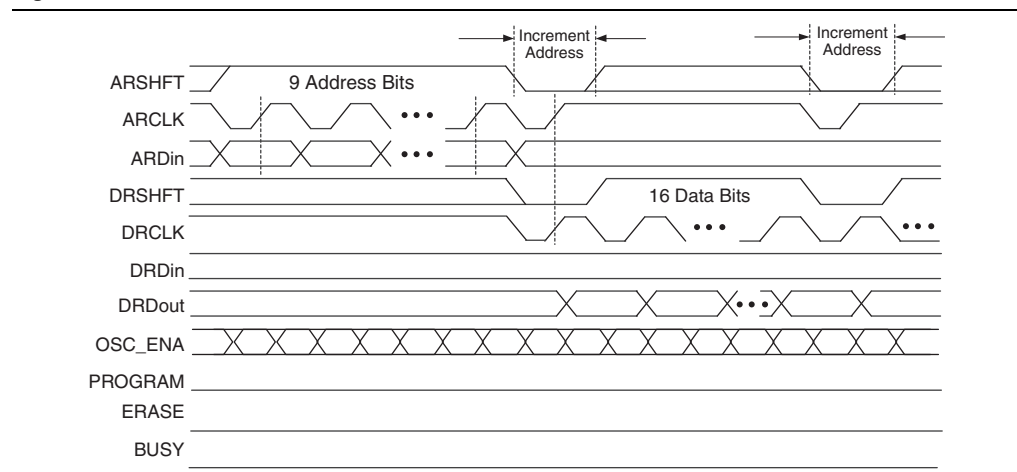

## Program

To program or write to the UFM, you must first perform a sequence to load the reference address into the address register. `DRSHFT` must then be asserted high to load the data serially into the data register starting with the MSB. Loading an address into the address register and loading data into the data register can be done concurrently. After the 16 bits of data have been successfully shifted into the data register, the `PROGRAM` signal must be asserted high to start writing to the UFM. On the rising edge, the data currently in the data register is written to the location currently in the address register. The `BUSY` signal is asserted until the program sequence is completed. The data and address register should not be modified until the `BUSY` signal is de-asserted, or the flash content will be corrupted. The `PROGRAM` signal is ignored if the `BUSY` signal is asserted. When the `PROGRAM` signal is applied at exactly the same time as the `ERASE` signal, the behavior is undefined and the flash content is corrupted. Figure 7-7 shows the UFM waveforms during program mode.

**Figure 7-7. UFM Program Waveforms**

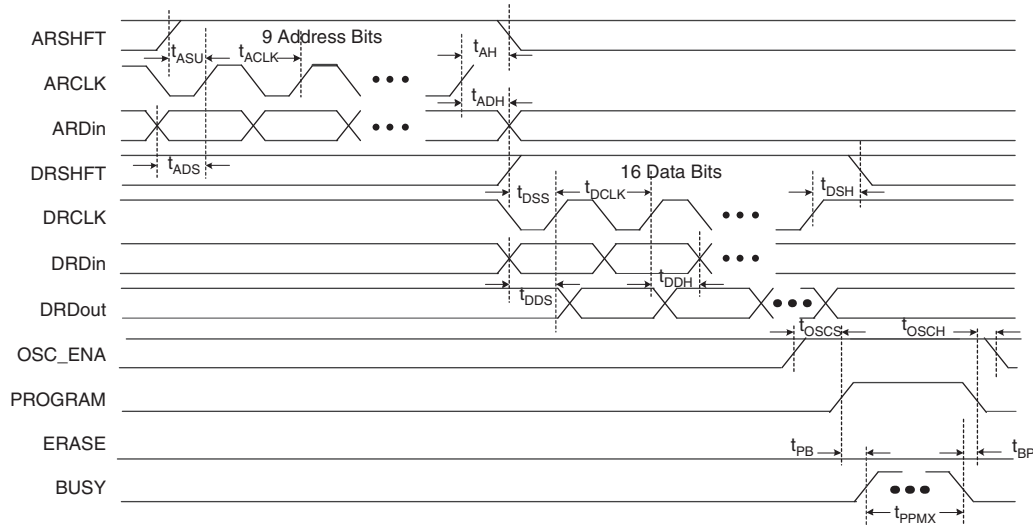

## Erase

The ERASE signal initiates an erase sequence to erase one sector of the UFM. The data register is not needed to perform an erase sequence. To indicate the sector of the UFM to be erased, the MSB of the address register should be loaded with 0 to erase UFM sector 0, or 1 to erase UFM sector 1 (Figure 7-2 on page 7-5). On a rising edge of the ERASE signal, the memory sector indicated by the MSB of the address register will be erased. The BUSY signal is asserted until the erase sequence is completed. The address register should not be modified until the BUSY signal is de-asserted to prevent the flash content from being corrupted. This ERASE signal is ignored when the BUSY signal is asserted. Figure 7-8 illustrates the UFM waveforms during erase mode.



When the UFM sector is erased, it has 16-bit locations all filled with FFFF. Each UFM storage bit can be programmed only once between erase sequences. You can write to any word up to two times providing the second programming attempt at that location only adds 0s. 1s are mask bits for your input word that cannot overwrite 0s in the flash array. New 1s in the location can only be achieved by an erase. Therefore, it is possible for you to perform byte writes because the UFM array is 16 bits for each location.

**Figure 7-8. UFM Erase Waveforms**

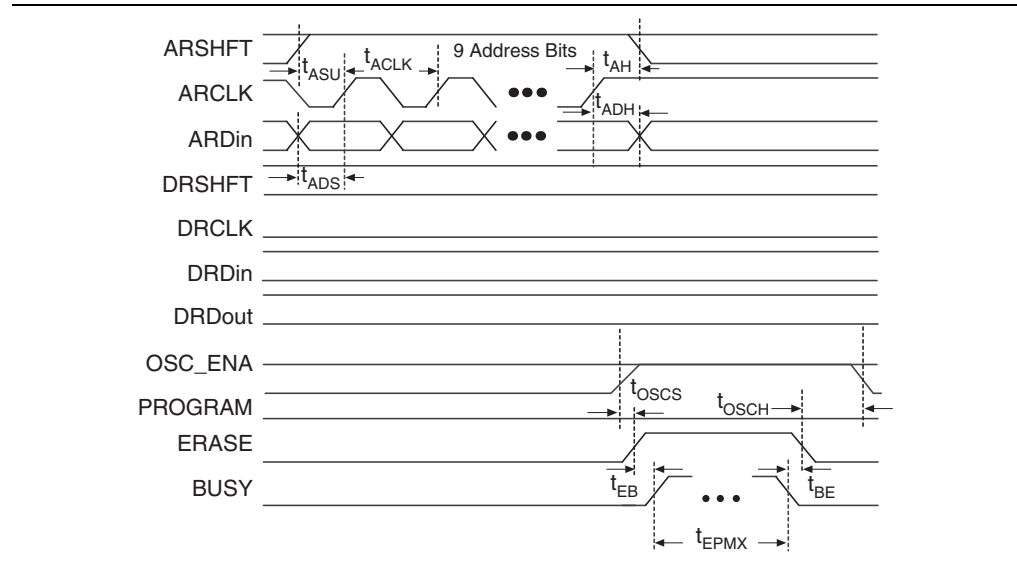

## Programming and Reading the UFM with JTAG

In MAX V devices, you can write data to or read data from the UFM using the IEEE Std. 1149.1 JTAG interface. You can use a PC or UNIX workstation, the Quartus II Programmer, or the ByteBlasterMV™ or ByteBlaster™ II parallel port download cable to download Programmer Object File (.pof), Jam™ Standard Test and Programming Language (STAPL) Files (.jam), or Jam Byte-Code Files (.jbc) from the Quartus II software targeting the MAX V device UFM block.



The .pof, .jam, and .jbc files can be generated using the Quartus II software.

### Jam Files

Both .jam STAPL and .jbc files support programming for the UFM block.

### Jam Players

Jam Players read the descriptive information in Jam files and translate them into data that programs the target device. Jam Players do not program a particular device architecture or vendor; they only read and understand the syntax defined by the Jam file specification. In-field changes are confined to the Jam file, not the Jam Player. As a result, you do not need to modify the Jam Player source code for each in-field upgrade.

There are two types of Jam Players to accommodate the two types of Jam files: an ASCII Jam STAPL Player and a Jam STAPL Byte-Code Player. Both ASCII Jam STAPL Player and Jam STAPL Byte-Code Player are coded in the C programming language for 16-bit and 32-bit processors.



For information about UFM operation during ISP, refer to *AN 100: In-System Programmability Guidelines*.

## Software Support for UFM Block

The Altera Quartus II software includes sophisticated tools that fully utilize the advantages of the UFM block in MAX V devices, while maintaining simple, easy-to-use procedures that accelerate the design process. The following section describes how the ALTUFM megafunction supports a simple design methodology for instantiating standard interface protocols for the UFM block, such as:

- I<sup>2</sup>C
- SPI
- Parallel
- None (Altera Serial Interface)

This section includes the megafunction symbol, the input and output ports, and a description of the MegaWizard Plug-In Manager options. Refer to Quartus II Help for the ALTUFM megafunction Altera Hardware Description Language (AHDL) functional prototypes (applicable to Verilog HDL), VHDL component declarations, and parameter descriptions. You can access this megafunction from the Memory Compiler directory on page 2a of the MegaWizard Plug-In Manager.

The ALTUFM MegaWizard Plug-In Manager has separate pages that apply to the MAX V UFM block. During compilation, the Quartus II Compiler verifies the ALTUFM parameters selected against the available logic array interface options, and any specific assignments.

### Inter-Integrated Circuit

Inter-Integrated Circuit (I<sup>2</sup>C) is a bidirectional two-wire interface protocol, requiring only two bus lines: a serial data/address line (SDA), and a serial clock line (SCL). Each device connected to the I<sup>2</sup>C bus is software addressable by a unique address. The I<sup>2</sup>C bus is a multi-master bus where more than one integrated circuit (IC) capable of initiating a data transfer can be connected to it, which allows masters to function as transmitters or receivers.

The ALTUFM\_I2C megafunction features a serial, 8-bit bidirectional data transfer up to 100 Kbits per second. With the ALTUFM\_I2C megafunction, the MAX V UFM and logic can be configured as a slave device for the I<sup>2</sup>C bus. The ALTUFM megafunction's I<sup>2</sup>C interface is designed to function similar to I<sup>2</sup>C serial EEPROMs.

The Quartus II software supports four different memory sizes:

- (128 × 8) 1 Kbits
- (256 × 8) 2 Kbits
- (512 × 8) 4 Kbits
- (1,024 × 8) 8 Kbits

#### I<sup>2</sup>C Protocol

The following defines the characteristics of the I<sup>2</sup>C bus protocol:

- Only two bus lines are required: SDA and SCL. Both SDA and SCL are bidirectional lines that remain high when the bus is free.

- Data transfer can be initiated only when the bus is free.
- The data on the SDA line must be stable during the high period of the clock. The high or low state of the data line can only change when the clock signal on the SCL line is low.
- Any transition on the SDA line while the SCL is high indicates a start or stop condition.

Table 7-5 lists the ALTUFM\_I2C megafunction input and output interface signals.

**Table 7-5. ALTUFM\_I2C Interface Signals**

Pin	Description	Function
SDA	Serial Data/Address Line	The bidirectional SDA port is used to transmit and receive serial data from the UFM. The output stage of the SDA port is configured as an open drain pin to perform the wired-AND function.
SCL	Serial Clock Line	The bidirectional SCL port is used to synchronize the serial data transfer to and from the UFM. The output stage of the SCL port is configured as an open drain pin to perform a wired-AND function.
WP	Write Protect	Optional active high signal that disables the erase and write function for read/write mode. The ALTUFM_I2C megafunction gives you an option to protect the entire UFM memory or only the upper half of memory.
A <sub>2</sub> , A <sub>1</sub> , A <sub>0</sub>	Slave Address Input	These inputs set the UFM slave address. The A <sub>6</sub> , A <sub>5</sub> , A <sub>4</sub> , A <sub>3</sub> slave address bits are programmable, set internally to 1010 by default.

#### START and STOP Condition

The master always generates start (S) and stop (P) conditions. After the start condition, the bus is considered busy. Only a stop (P) condition frees the bus. The bus stays busy if the repeated start (Sr) condition is executed instead of a stop condition. In this occurrence, the start (S) and repeated start (Sr) conditions are functionally identical.

A high-to-low transition on the SDA line while the SCL is high indicates a start condition. A low-to-high transition on the SDA line while the SCL is high indicates a stop condition. Figure 7-9 shows the start and stop conditions.

**Figure 7-9. Start and Stop Conditions**

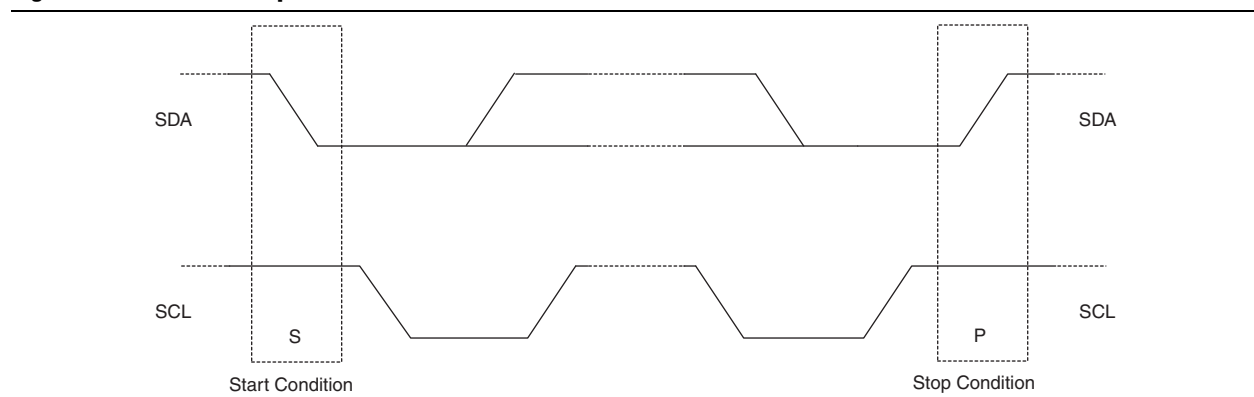

### Acknowledge

Acknowledged data transfer is a requirement of I<sup>2</sup>C. The master must generate a clock pulse to signify the acknowledge bit. The transmitter releases the SDA line (high) during the acknowledge clock pulse.

The receiver (slave) must pull the SDA line low during the acknowledge clock pulse so that SDA remains a stable low during the clock high period, indicating positive acknowledgement from the receiver. If the receiver pulls the SDA line high during the acknowledge clock pulse, the receiver sends a not-acknowledge condition indicating that it is unable to process the last byte of data. If the receiver is busy (for example, executing an internally-timed erase or write operation), it will not acknowledge any new data transfer. Figure 7-10 shows the acknowledge condition on the I<sup>2</sup>C bus.

Figure 7-10. Acknowledge on the I<sup>2</sup>C Bus

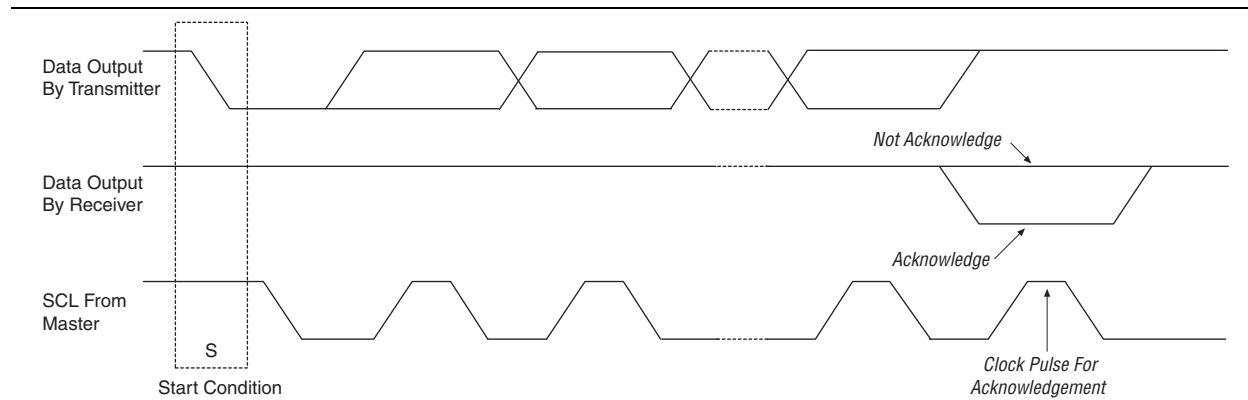

### Device Addressing

After the start condition, the master sends the address of the particular slave device it is requesting. The four most significant bits (MSBs) of the 8-bit slave address are usually fixed while the next three significant bits ( $A_2$ ,  $A_1$ ,  $A_0$ ) are device address bits that define which device the master is accessing. The last bit of the slave address specifies whether a read or write operation is to be performed. When this bit is set to 1, a read operation is selected. When this bit is set to 0, a write operation is selected.

The four MSBs of the slave address ( $A_6$ ,  $A_5$ ,  $A_4$ ,  $A_3$ ) are programmable and can be defined on page 3 of the ALTUFM MegaWizard Plug-In Manager. The default value for these four MSBs is 1010. The next three significant bits are defined using the three  $A_2$ ,  $A_1$ ,  $A_0$  input ports of the ALTUFM\_I2C megafunction. You can connect these ports to input pins in the design file and connect them to switches on the board. The other option is to connect them to  $V_{CC}$  and GND primitives in the design file, which conserves pins. Figure 7-11 shows the slave address bits.

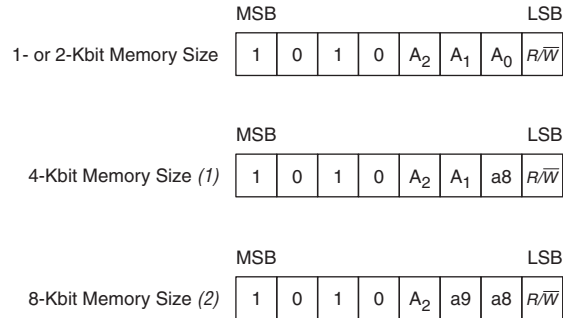
**Figure 7-11. Slave Address Bits****Notes to Figure 7-11:**

- (1) For the 4-Kbit memory size, the  $A_0$  location in the slave address becomes the MSB (a8) of the memory byte address.
- (2) For the 8-Kbit memory size, the  $A_0$  location in the slave address becomes a8 of the memory byte address, while the  $A_1$  location in the slave address becomes the MSB (a9) of the memory byte address.

After the master sends a start condition and the slave address byte, the ALTUFM\_I2C logic monitors the bus and responds with an acknowledge (on the SDA line) when its address matches the transmitted slave address. The ALTUFM\_I2C megafunction then performs a read or write operation to or from the UFM, depending on the state of the bit.

**Byte Write Operation**

The master initiates a transfer by generating a start condition, then sending the correct slave address (with the R/W bit set to 0) to the slave. If the slave address matches, the ALTUFM\_I2C slave acknowledges on the ninth clock pulse. The master then transfers an 8-bit byte address to the UFM, which acknowledges the reception of the address. The master transfers the 8-bit data to be written to the UFM. After the ALTUFM\_I2C logic acknowledges the reception of the 8-bit data, the master generates a stop condition. The internal write from the MAX V logic array to the UFM begins only after the master generates a stop condition. While the UFM internal write cycle is in progress, the ALTUFM\_I2C ignores any attempt made by the master to initiate a new transfer. Figure 7-12 shows the byte write sequence.

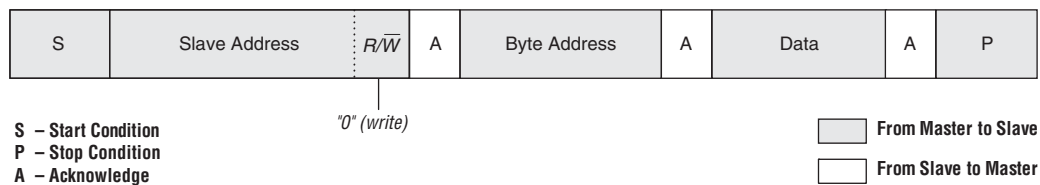
**Figure 7-12. Byte Write Sequence**

## Page Write Operation

Page write operation has a similar sequence as the byte write operation, except that several bytes of data are transmitted in sequence before the master issues a stop condition. The internal write from the MAX V logic array to the UFM begins only after the master generates a stop condition. While the UFM internal write cycle is in progress, the ALTUFM\_I2C logic ignores any attempt made by the master to initiate a new transfer. The ALTUFM\_I2C megafunction only allow 16 bytes for the page write operation.

A write operation is only possible to an erased UFM block or word location. The UFM block differs from serial EEPROMs, requiring an erase operation before writing new data in the UFM block. A special erase sequence is required, as discussed in “[Erase Operation](#)”.

## Acknowledge Polling

The master can detect whether the internal write cycle is completed by polling for an acknowledgement from the slave. The master can re-send the start condition together with the slave address as soon as the byte write sequence is finished. The slave does not acknowledge if the internal write cycle is still in progress. The master can repeat the acknowledge polling and proceed with the next instruction after the slave acknowledges.

## Write Protection

The ALTUFM\_I2C megafunction includes an optional Write Protection (WP) port available on page 4 of the ALTUFM MegaWizard Plug-In Manager. In the MegaWizard Plug-In Manager, you can choose the WP port to protect either the full or upper half memory.

When WP is set to 1, the upper half or the entire memory array (depending on the write protection level selected) is protected, and the write and erase operations are not allowed. The ALTUFM\_I2C megafunction acknowledges the slave address and memory address. After the master transfers the first data byte, the ALTUFM\_I2C megafunction sends a not-acknowledge condition to the master to indicate that the instruction will not execute. When WP is set to 0, the write and erase operations are allowed.

## Erase Operation

Commercial serial EEPROMs automatically erase each byte of memory before writing into that particular memory location during a write operation. However, the MAX V UFM block is flash based and only supports sector erase operations. Byte erase operations are not supported. When using read/write mode, a sector or full memory erase operation is required before writing new data into any location that previously contained data. The block cannot be erased when the ALTUFM\_I2C megafunction is in read-only mode.

Data can be initialized into memory for read/write and read-only modes by including a memory initialization file (.mif) or hexadecimal file (.hex) in the ALTUFM MegaWizard Plug-In Manager. This data is automatically written into the UFM during device programming by the Quartus II software or third-party programming tool.

The ALTUFM\_I2C megafunction supports four different erase operation methods shown on page 4 of the ALTUFM MegaWizard Plug-In Manager:

- Full Erase (Device Slave Address Triggered)
- Sector Erase (Byte Address Triggered)
- Sector Erase ( $A_2$  Triggered)
- No Erase

These erase options only work as described if that particular option is selected in the MegaWizard Plug-In Manager before compiling the design files and programming the device. Only one option can be selected for the ALTUFM\_I2C megafunction.

Each erase option is discussed in more detail in the following sections.

### Full Erase (Device Slave Address Triggered)

The full erase option uses the  $A_2$ ,  $A_1$ ,  $A_0$  bits of the slave address to distinguish between an erase or read/write operation. This slave operation decoding occurs when the master transfers the slave address to the slave after generating the start condition. If the  $A_2$ ,  $A_1$ , and  $A_0$  slave address bits transmitted to the UFM slave equals 111 and the four remaining MSBs match the rest of the slave addresses, then the Full Erase operation is selected. If the  $A_6$ ,  $A_5$ ,  $A_4$ ,  $A_3$ ,  $A_2$ ,  $A_1$ , and  $A_0$  slave address bits transmitted to the UFM match its unique slave address setting, the read/write operation is selected and functions as expected. As a result, this erase option utilizes two slave addresses on the bus reserving  $A_6$ ,  $A_5$ ,  $A_4$ ,  $A_3$ , 1, 1, 1 as the erase trigger. Both sectors of the UFM block will be erased when the Full Erase operation is executed. This operation requires acknowledge polling. The internal UFM erase function only begins after the master generates a stop condition. Figure 7-13 shows the full erase sequence triggered by using the slave address.

If the memory is write-protected ( $WP = 1$ ), the slave does not acknowledge the erase trigger slave address ( $A_6$ ,  $A_5$ ,  $A_4$ ,  $A_3$ , 1, 1, 1) sent by the master. The master should then send a stop condition to terminate the transfer. The full erase operation will not be executed.

**Figure 7-13. Full Erase Sequence Triggered Using the Slave Address**

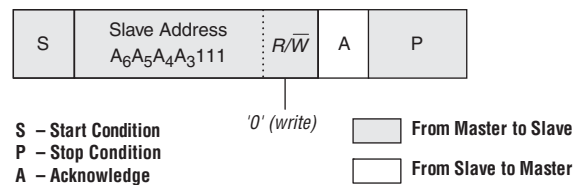

### Sector Erase (Byte Address Triggered)

This sector erase operation is triggered by defining a 7- to 10-bit byte address for each sector depending on the memory size. The trigger address for each sector is entered on page 4 of the ALTUFM MegaWizard Plug-In Manager. When a write operation is executed targeting this special byte address location, the UFM sector that contains that byte address location is erased. This sector erase operation is automatically followed by a write of the intended write byte to that address. The default byte address location for UFM Sector 0 erase is address 0x00. The default byte address location for UFM Sector 1 erase is [(selected memory size)/2]. You can specify another byte location as the trigger-erase addresses for each sector.

This sector erase operation supports up to eight UFM blocks or serial EEPROMs on the I<sup>2</sup>C bus. This sector erase operation requires acknowledge polling.

### Sector Erase (A<sub>2</sub> Triggered)

This sector erase operation uses the received A<sub>2</sub> slave address bit to distinguish between an erase or read/write operation. This slave operation decoding occurs when the master transmits the slave address after generating the start condition. If the A<sub>2</sub> bit received by the UFM slave is 1, the sector erase operation is selected. If the A<sub>2</sub> bit received is 0, the read/write operation is selected. While this reserves the A<sub>2</sub> bit as an erase or read/write operation bit, the A<sub>0</sub> and A<sub>1</sub> bits still act as slave address bits to address the UFM. With this erase option, there can be up to four UFM slaves cascaded on the bus for 1-Kbit and 2-Kbit memory sizes. Only two UFM slaves can be cascaded on the bus for 4-Kbit memory size, because A<sub>0</sub> of the slave address becomes the ninth bit (MSB) of the byte address. After the slave acknowledges the slave address and its erase or read/write operation bit, the master can transfer any byte address within the sector that must be erased. The internal UFM sector erase operation only begins after the master generates a stop condition. Figure 7-14 shows the sector erase sequence using the A<sub>2</sub> bit of the slave address.

**Figure 7-14. Sector Erase Sequence Indicated Using the A<sub>2</sub> Bit of the Slave Address**

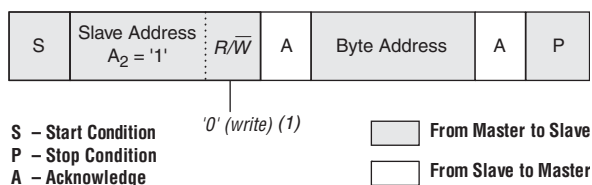

**Note to Figure 7-14:**

(1) A<sub>2</sub> = 0 indicates a read/write operation is executed in place of an erase. Here, the R/W bit determines whether it is a read or write operation.

If the ALTUFM\_I2C megafunction is write-protected (WP=1), the slave does not acknowledge the byte address (that indicates the UFM sector to be erased) sent in by the master. The master should then send a stop condition to terminate the transfer and the sector erase operation will not be executed.

### No Erase

The no erase operation never erases the UFM contents. This method is recommended when UFM does not require constant re-writing after its initial write of data. For example, if the UFM data is to be initialized with data during manufacturing using I<sup>2</sup>C, you may not require writing to the UFM again. In that case, you should use the no erase option and save LE resources from being used to create erase logic.

### Read Operation

The read operation is initiated in the same manner as the write operation except that the R/W bit must be set to 1. Three different read operations are supported:

- Current Address Read (Single Byte)
- Random Address Read (Single byte)
- Sequential Read (Multi-Byte)

After each UFM data has been read and transferred to the master, the UFM address register is incremented for all single and multi-byte read operations.

#### Current Address Read

This read operation targets the current byte location pointed to by the UFM address register. [Figure 7-15](#) shows the current address read sequence.

**Figure 7-15. Current Address Read Sequence**

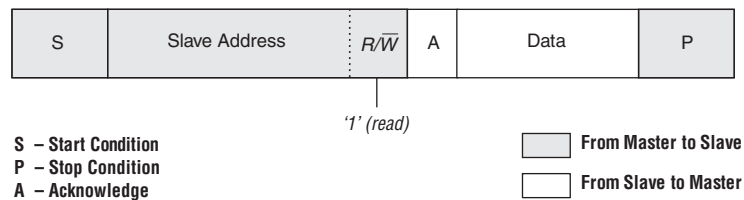

### Random Address Read

Random address read operation allows the master to select any byte location for a read operation. The master first performs a “dummy” write operation by sending the start condition, slave address, and byte address of the location it wishes to read. After the ALTUFM\_I2C megafunction acknowledges the slave and byte address, the master generates a repeated start condition, the slave address, and the R/W bit is set to 1. The ALTUFM\_I2C megafunction then responds with acknowledge and sends the 8-bit data requested. The master then generates a stop condition. Figure 7-16 shows the random address read sequence.

Figure 7-16. Random Address Read Sequence

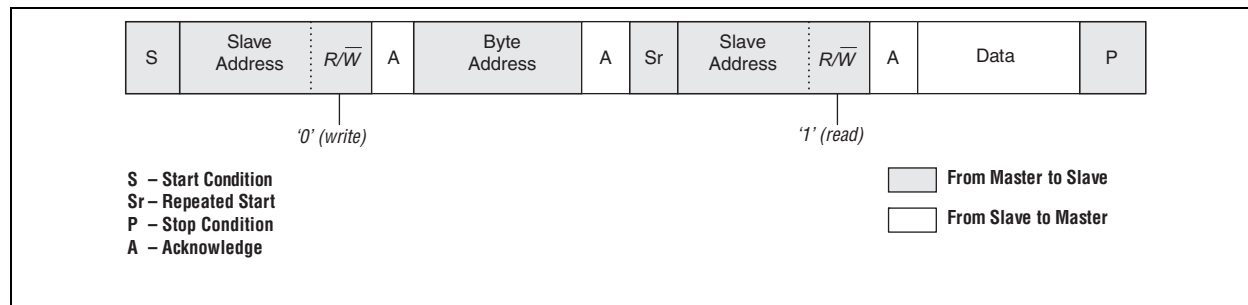

### Sequential Read

Sequential read operation can be initiated by either the current address read operation or the random address read operation. Instead of sending a stop condition after the slave has transmitted one byte of data to the master, the master acknowledges that byte and sends additional clock pulses (on the SCL line) for the slave to transmit data bytes from consecutive byte addresses. The operation is terminated when the master generates a stop condition instead of responding with an acknowledge. Figure 7-17 shows the sequential read sequence.

Figure 7-17. Sequential Read Sequence

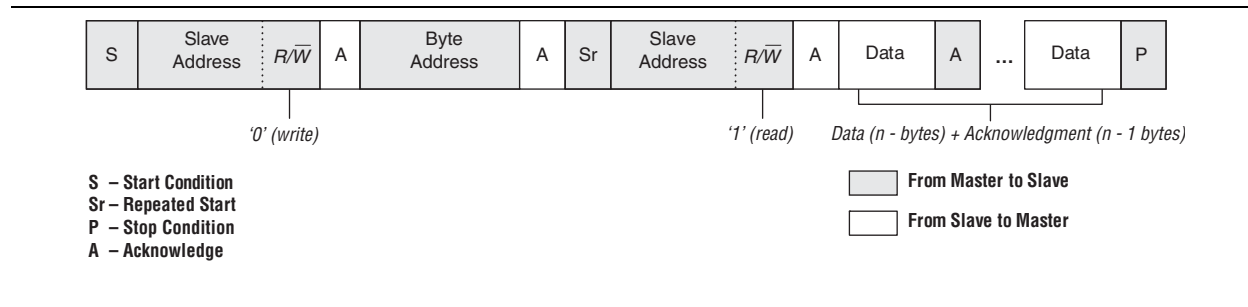

## ALTUFM\_I2C Interface Timing Specification

Figure 7-18 shows the timing waveform for the ALTUFM\_I2C megafunction read/write mode.

**Figure 7-18. Timing Waveform for the ALTUFM\_I2C Megafunction**

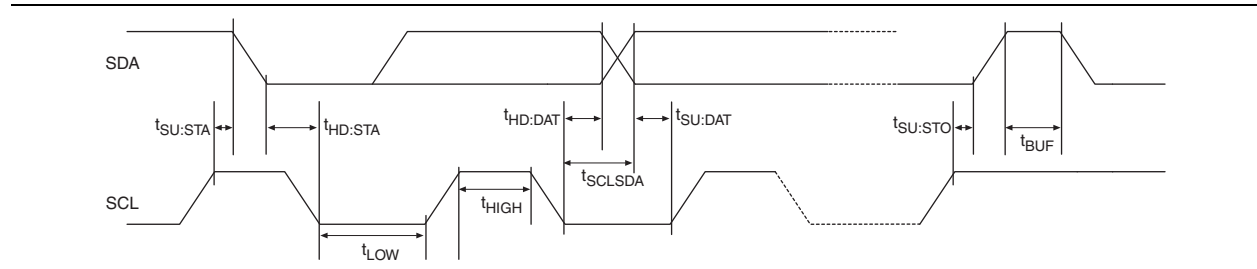

Table 7-6 through Table 7-8 list the timing specification needed for the ALTUFM\_I2C megafunction read/write mode.

**Table 7-6. I2C Interface Timing Specification**

Symbol	Parameter	Min	Max	Unit
$F_{SCL}$	SCL clock frequency	—	100	kHz
$t_{SCL:SDA}$	SCL going low to SDA data out	—	15	ns
$t_{BUF}$	Bus free time between a stop and start condition	4.7	—	$\mu$ s
$t_{HD:STA}$	(Repeated) start condition hold time	4	—	$\mu$ s
$t_{SU:STA}$	(Repeated) start condition setup time	4.7	—	$\mu$ s
$t_{LOW}$	SCL clock low period	4.7	—	$\mu$ s
$t_{HIGH}$	SCL clock high period	4	—	$\mu$ s
$t_{HD:DAT}$	SDA data in hold time	0	—	ns
$t_{SU:DAT}$	SDA data in setup time	20	—	ns
$t_{SU:STO}$	STOP condition setup time	4	—	ns

**Table 7-7. UFM Write Cycle Time**

Parameter	Min	Max	Unit
Write Cycle Time	—	110	$\mu$ s

**Table 7-8. UFM Erase Cycle Time**

Parameter	Min	Max	Unit
Sector Erase Cycle Time	—	501	ms
Full Erase Cycle Time	—	1,002	ms

## Instantiating the I<sup>2</sup>C Interface Using the Quartus II ALTUFM\_I2C Megafunction

Figure 7-19 shows the ALTUFM\_I2C megafunction symbol for a I<sup>2</sup>C interface instantiation in the Quartus II software.

**Figure 7-19. ALTUFM\_I2C Megafunction Symbol for the I<sup>2</sup>C Interface Instantiation in the Quartus II Software**

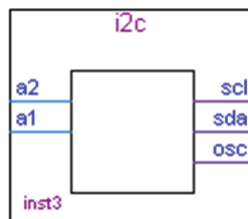

ALTUFM\_I2C megafunction is under the **Memory Compiler** folder on page 2a of the MegaWizard Plug-In Manager. On page 3, you can choose whether to implement the **Read/Write** or **Read Only** mode for the UFM. You also have an option to choose the memory size for the ALTUFM\_I2C megafunction as well as defining the four MSBs of the slave address (default 1010).

You can select the optional write protection and erase operation methods on page 4 of the ALTUFM MegaWizard Plug-In Manager.



The UFM block's internal oscillator is always running when the ALTUFM\_I2C megafunction is instantiated for both read-only and read/write interfaces.

## Serial Peripheral Interface

Serial peripheral interface (SPI) is a four-pin serial communication subsystem included on the Motorola 6805 and 68HC11 series microcontrollers. It allows the microcontroller unit to communicate with peripheral devices, and is also capable of inter-processor communications in a multiple-master system.

The SPI bus consists of masters and slaves. The master device initiates and controls the data transfers and provides the clock signal for synchronization. The slave device responds to the data transfer request from the master device. The master device in an SPI bus initiates a service request with the slave devices responding to the service request.

With the ALTUFM megafunction, the UFM and MAX V logic can be configured as a slave device for the SPI bus. The OSC\_ENA is always asserted to enable the internal oscillator when the SPI megafunction is instantiated for both read only and read/write interfaces.

The Quartus II software supports both the Base mode (uses 8-bit address and data) and the Extended mode (uses 16-bit address and data). Base mode uses only UFM sector 0 (2,048 bits), while Extended mode uses both UFM sector 0 and sector 1 (8,192 bits). There are only four pins in SPI: *SI*, *SO*, *SCK*, and *nCS*. Table 7-9 describes the SPI pins and functions.

**Table 7-9. SPI Interface Signals**

Pin	Description	Function
<i>SI</i>	Serial Data Input	Receive data serially.
<i>SO</i>	Serial Data Output	Transmit data serially.
<i>SCK</i>	Serial Data Clock	The clock signal produced from the master device to synchronize the data transfer.
<i>nCS</i>	Chip Select	Active low signal that enables the slave device to receive or transfer data from the master device.

Data transmitted to the *SI* port of the slave device is sampled by the slave device at the positive *SCK* clock. Data transmits from the slave device through *SO* at the negative *SCK* clock edge. When *nCS* is asserted, it means the current device is being selected by the master device from the other end of the SPI bus for service. When *nCS* is not asserted, the *SI* and *SCK* ports should be blocked from receiving signals from the master device, and *SO* should be in High Impedance state to avoid causing contention on the shared SPI bus. All instructions, addresses, and data are transferred with the MSB first and start with high-to-low *nCS* transition. The circuit diagram is shown in Figure 7-20.

**Figure 7-20. Circuit Diagram for SPI Interface Read or Write Operations**

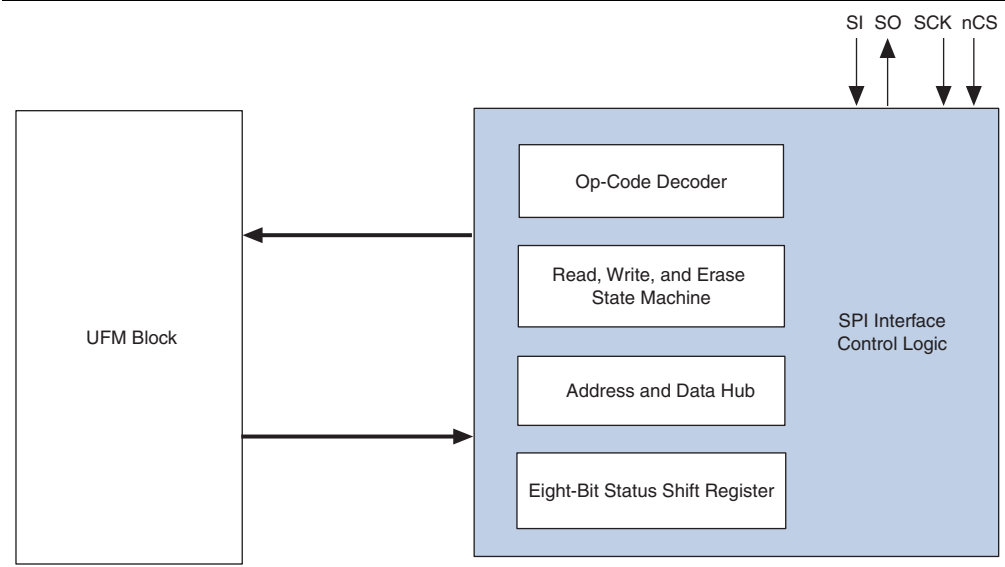

## Opcodes

Table 7-10 lists the 8-bit instruction opcodes. After nCS is pulled low, the indicated opcode must be provided. Otherwise, the interface assumes that the master device has internal logic errors and ignores the rest of the incoming signals. When nCS is pulled back to high, the interface is back to normal. nCS should be pulled low again for a new service request.

**Table 7-10. Instruction Set for SPI**

Name	Opcode	Operation
WREN	00000110	Enable Write to UFM
WRDI	00000100	Disable Write to UFM
RDSR	00000101	Read Status Register
WRSR	00000001	Write Status Register
READ	00000011	Read data from UFM
WRITE	00000010	Write data to UFM
SECTOR-ERASE	00100000	Sector erase
UFM-ERASE	01100000	Erase the entire UFM block (both sectors)

The READ and WRITE opcodes are instructions for transmission, which means the data will be read from or written to the UFM.

WREN, WRDI, RDSR, and WRSR are instructions for the status register, where they do not have any direct interaction with UFM, but read or set the status register within the interface logic. The status register provides status on whether the UFM block is available for any READ or WRITE operation, whether the interface is WRITE enabled, and the state of the UFM WRITE protection. Table 7-11 lists the status register format. For the read only implementation of ALTUFM SPI (Base or Extended mode), the status register does not exist, saving LE resources.

**Table 7-11. Status Register Format**

Position	Status	Default at Power-Up	Description
Bit 7	X	0	—
Bit 6	X	0	—
Bit 5	X	0	—
Bit 4	X	0	—
Bit 3	BP1	0	Indicate the current level of block write protection (1)
Bit 2	BP0	0	Indicate the current level of block write protection (1)
Bit 1	WEN	0	1= SPI WRITE enabled state 0= SPI WRITE disabled state
Bit 0	nRDY	0	1 = Busy, UFM WRITE or ERASE cycle in progress 0 = No UFM WRITE or ERASE cycle in progress

**Note to Table 7-11:**

(1) For more information about status register bits BP1 and BP0, refer to Table 7-12 and Table 7-13 on page 7-34.

The following sections describe the instructions for SPI.

**READ**

READ is the instruction for data transmission, where the data is read from the UFM block. When data transfer is taking place, the MSB is always the first bit to be transmitted or received. The data output stream is continuous through all addresses until it is terminated by a low-to-high transition at the nCS port. The READ operation is always performed through the following sequence in SPI, as shown in Figure 7-21:

1. nCS is pulled low to indicate the start of transmission.
2. An 8-bit READ opcode (00000011) is received from the master device. (If internal programming is in progress, READ is ignored and not accepted).
3. A 16-bit address is received from the master device. The LSB of the address is received last. Because the UFM block can take only nine bits of address maximum, the first seven address bits received are discarded.
4. Data is transmitted for as many words as needed by the slave device through SO for READ operation. When the end of the UFM storage array is reached, the address counter rolls over to the start of the UFM to continue the READ operation.
5. nCS is pulled back to high to indicate the end of transmission.

For SPI Base mode, the READ operation is always performed through the following sequence in SPI:

1. nCS is pulled low to indicate the start of transmission.
2. An 8-bit READ opcode (00000011) is received from the master device, followed by an 8-bit address. If internal programming is in progress, the READ operation is ignored and not accepted.
3. Data is transmitted for as many words as needed by the slave device through SO for READ operation. The internal address pointer automatically increments until the highest memory address is reached (address 255 only because the UFM sector 0 is used). The address counter will not roll over when address 255 is reached. The SO output is set to high-impedance (Z) when all eight data bits from address 255 have been shifted out through the SO port.
4. nCS is pulled back to high to indicate the end of transmission.

**Figure 7-21. READ Operation Sequence for Extended Mode**

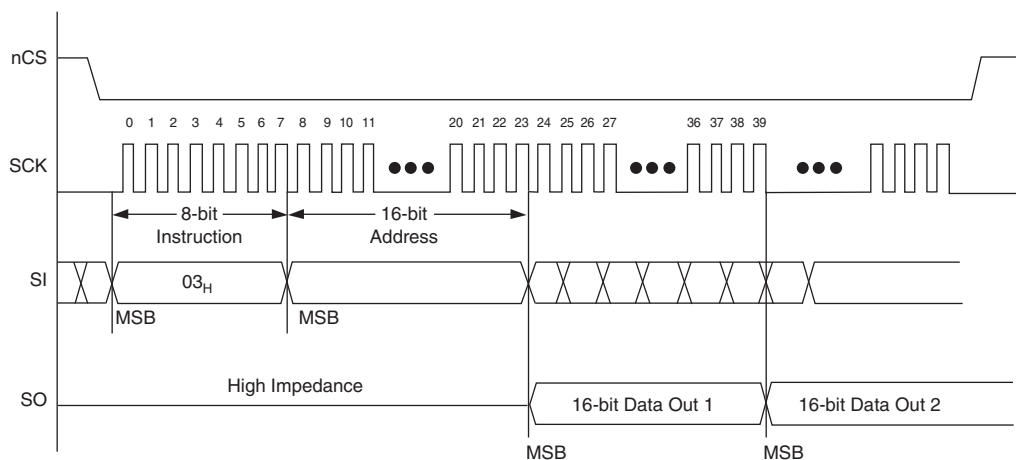
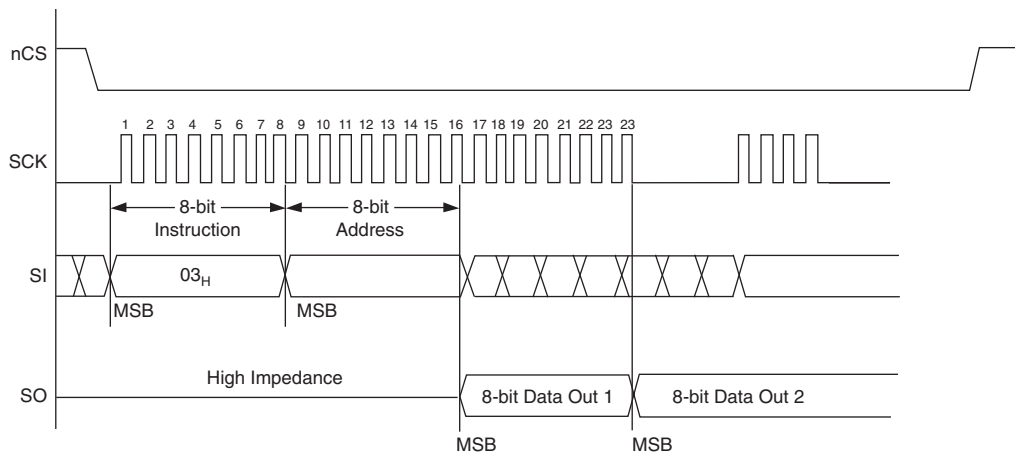

Figure 7-22 shows the READ operation sequence for Base mode.

**Figure 7-22. READ Operation for Base Mode**



### WRITE

WRITE is the instruction for data transmission, where the data is written to the UFM block. The targeted location in the UFM block that will be written must be in the erased state (FFFFH) before initiating a WRITE operation. When data transfer is taking place, the MSB is always the first bit to be transmitted or received. nCS must be driven high before the instruction is executed internally. You may poll the nRDY bit in the software status register for the completion of the internal self-timed WRITE cycle. For SPI Extended mode, the WRITE operation is always done through the following sequence, as shown in Figure 7-23:

1. nCS is pulled low to indicate the start of transmission.
2. An 8-bit WRITE opcode (00000010) is received from the master device. If internal programming is in progress, the WRITE operation is ignored and not accepted.
3. A 16-bit address is received from the master device. The LSB of the address will be received last. Because the UFM block can take only nine bits of address maximum, the first seven address bits received are discarded.
4. A check is carried out on the status register (see Table 7-11) to determine if the WRITE operation has been enabled, and the address is outside of the protected region; otherwise, Step 5 is bypassed.
5. One word (16 bits) of data is transmitted to the slave device through SI.
6. nCS is pulled back to high to indicate the end of transmission.

For SPI Base mode, the WRITE operation is always performed through the following sequence in SPI:

1. nCS is pulled low to indicate the start of transmission.
2. An 8-bit WRITE opcode (00000010) is received. If the internal programming is in progress, the WRITE operation is ignored and not accepted.
3. An 8-bit address is received. A check is carried out on the status register (see Table 7-11) to determine if the WRITE operation has been enabled, and the address is outside of the protected region; otherwise, Step 4 is skipped.

4. An 8-bit data is transmitted through SI.
5. nCS is pulled back to high to indicate the end of transmission.

**Figure 7-23. WRITE Operation Sequence for Extended Mode**

Figure 7-24 shows the WRITE operation sequence for Base mode.

**Figure 7-24. WRITE Operation Sequence for Base Mode**

### SECTOR-ERASE

SECTOR-ERASE (SE) is the instruction of erasing one sector of the UFM block. Each sector contains 256 words. WEN bit and the sector must not be protected for SE operation to be successful. nCS must be driven high before the instruction is executed internally. You may poll the nRDY bit in the software status register for the completion of the internal self-timed SECTOR-ERASE cycle. For SPI Extended mode, the SE operation is performed in the following sequence, as shown in Figure 7-25:

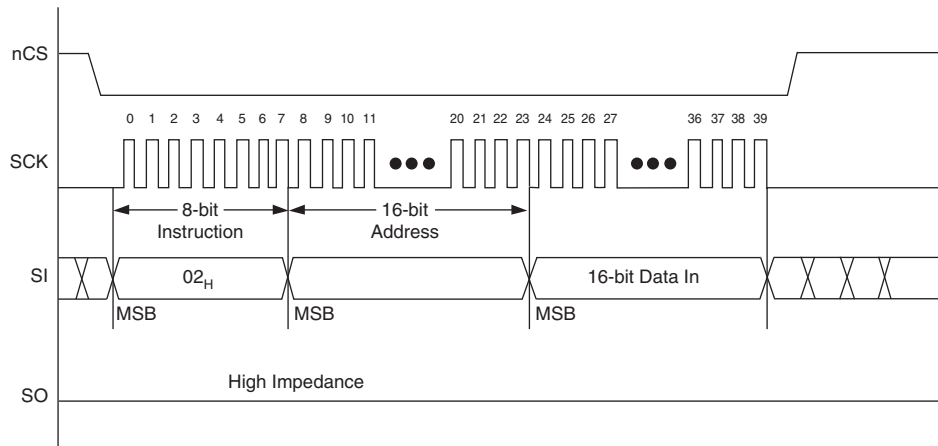
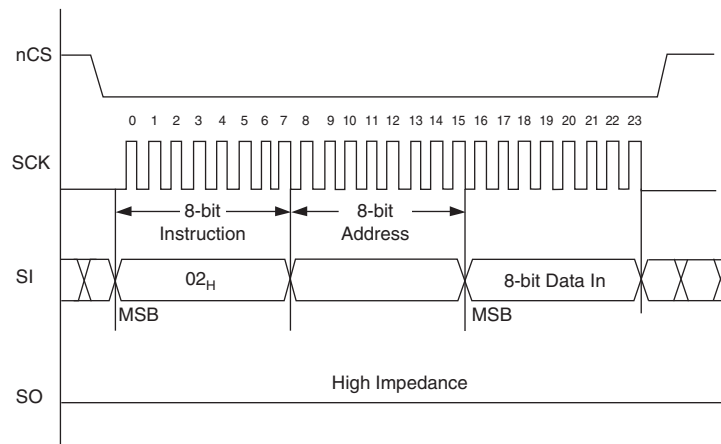
1. nCS is pulled low.
2. Opcode 00100000 is transmitted into the interface.
3. The 16-bit address is sent. The eighth bit (the first seven bits will be discarded) of the address indicates which sector is erased; a 0 means sector 0 (UFM0) is erased, and a 1 means sector 1 (UFM1) is erased.

- nCS is pulled back to high.

For SPI Base mode, the SE instruction erases UFM sector 0. Because there are no choices of UFM sectors to be erased, there is no address component to this instruction. The SE operation is always done through the following sequence in SPI Base mode:

- nCS is pulled low.
- Opcode 00100000 is transmitted into the interface.
- nCS is pulled back to high.

**Figure 7-25. SECTOR-ERASE Operation Sequence for Extended Mode**

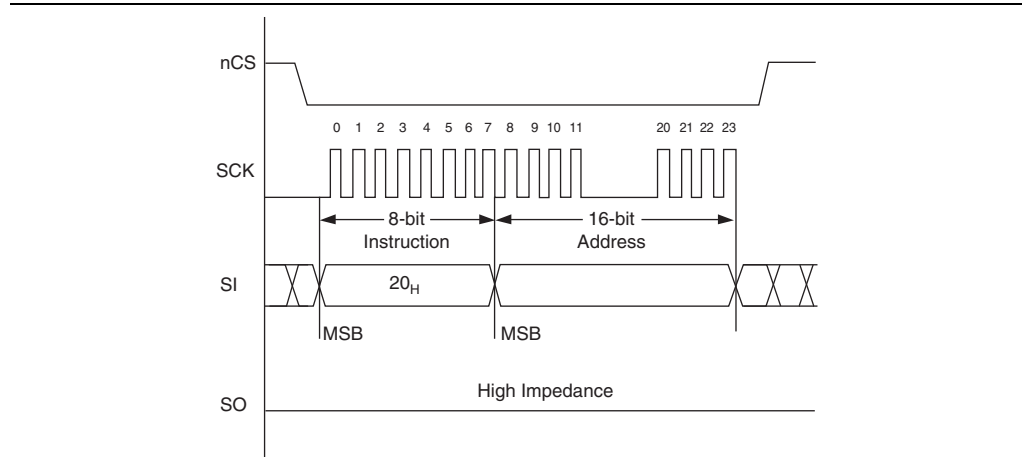
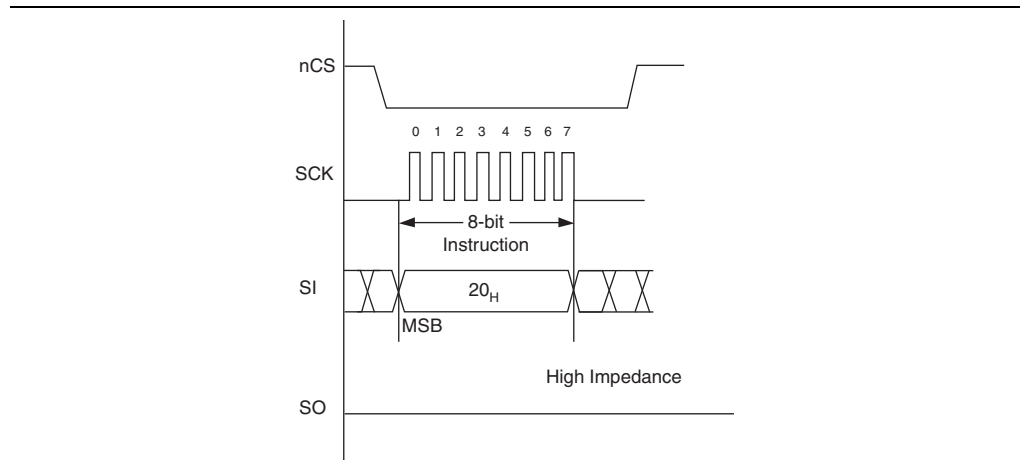

Figure 7-26 shows the SECTOR-ERASE operation sequence for Base mode.

**Figure 7-26. SECTOR\_ERASE Operation Sequence for Base Mode**



**UFM-ERASE**

The UFM-ERASE (CE) instruction erases both UFM sector 0 and sector 1 for SPI Extended Mode. While for SPI Base mode, the CE instruction has the same functionality as the SECTOR-ERASE (SE) instruction, which erases UFM sector 0 only. WEN bit and the UFM sectors must not be protected for CE operation to be successful. nCS must be driven high before the instruction is executed internally. You may poll the nRDY bit in the software status register for the completion of the internal self-timed CE cycle. For both SPI Extended mode and Base mode, the CE operation is performed in the following sequence as shown in Figure 7-27:

1. nCS is pulled low.
2. Opcode 01100000 is transmitted into the interface.
3. nCS is pulled back to high.

Figure 7-27 shows the UFM-ERASE operation sequence.

**Figure 7-27. UFM-ERASE Operation Sequence**

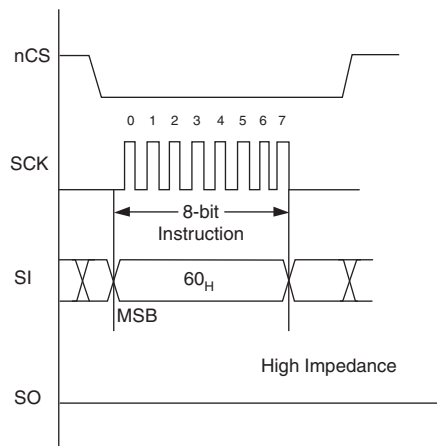

### WREN (Write Enable)

The interface is powered-up in the write disable state. Therefore, WEN in the status register (refer to Table 7-11) is 0 at power-up. Before any write is allowed to take place, WREN must be issued to set WEN in the status register to 1. If the interface is in read-only mode, WREN does not have any effect on WEN, because the status register does not exist. After WEN is set to 1, it can be reset by the WRDI instruction; the WRITE and SECTOR-ERASE instructions will not reset the WEN bit. WREN is issued through the following sequence, as shown in Figure 7-28:

1. nCS is pulled low.
2. Opcode 00000110 is transmitted into the interface to set WEN to 1 in the status register.
3. After the transmission of the eighth bit of WREN, the interface is in wait state (waiting for nCS to be pulled back to high). Any transmission after this is ignored.
4. nCS is pulled back to high.

Figure 7-28. WREN Operation Sequence

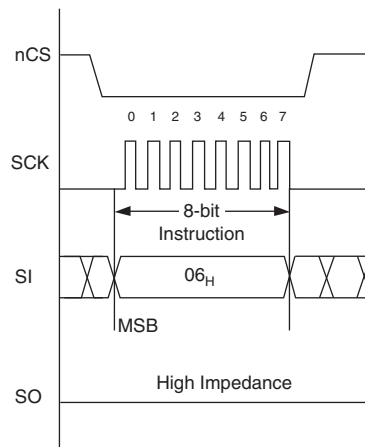

**WRDI (Write Disable)**

After the UFM is programmed, WRDI can be issued to set WEN back to 0, disabling WRITE and preventing inadvertent writing to the UFM. WRDI is issued through the following sequence, as shown in Figure 7-29:

1. nCS is pulled low.
2. Opcode 00000100 is transmitted to set WEN to 0 in the status register.
3. After the transmission of the eighth bit of WRDI, the interface is in wait state (waiting for nCS to be pulled back to high). Any transmission after this is ignored.
4. nCS is pulled back to high.

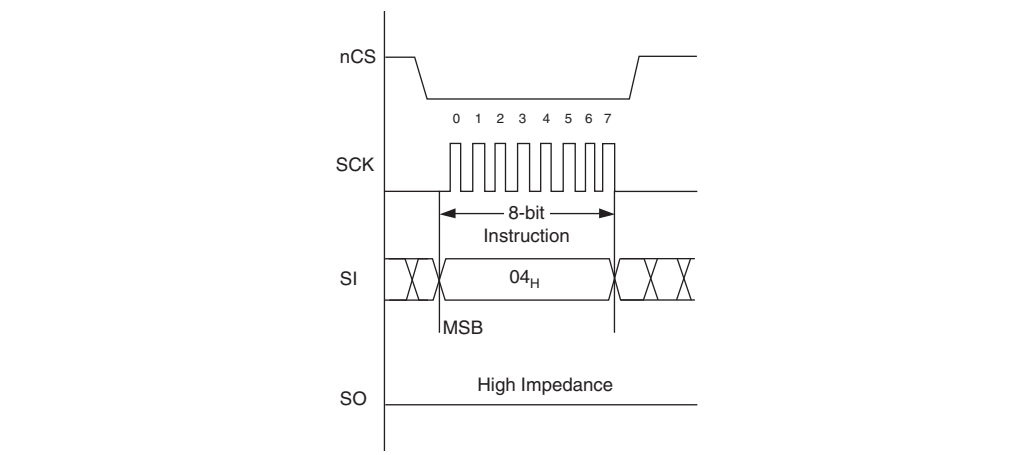
**Figure 7-29. WRDI Operation Sequence**

### RDSR (Read Status Register)

The content of the status register can be read by issuing RDSR. After RDSR is received, the interface outputs the content of the status register through the SO port. Although the four most significant bits (Bit 7 to Bit 4) do not hold valuable information, all eight bits in the status register will output through the SO port. This allows future compatibility when Bit 7 to Bit 4 have new meaning in the status register. During the internal program cycle in the UFM, RDSR is the only valid opcode recognized by the interface (therefore, the status register can be read at any time), and nRDY is the only valid status bit. Other status bits are frozen and remain unchanged until the internal program cycle is ended. RDSR is issued through the following sequence, as shown in Figure 7-30:

1. nCS is pulled low.
2. Opcode 00000101 is transmitted into the interface.
3. SI ignores incoming signals; SO outputs the content of the status register, Bit 7 first and Bit 0 last.
4. If nCS is kept low, repeat step 3.
5. nCS is pulled back to high to terminate the transmission.

**Figure 7-30. RDSR Operation Sequence**

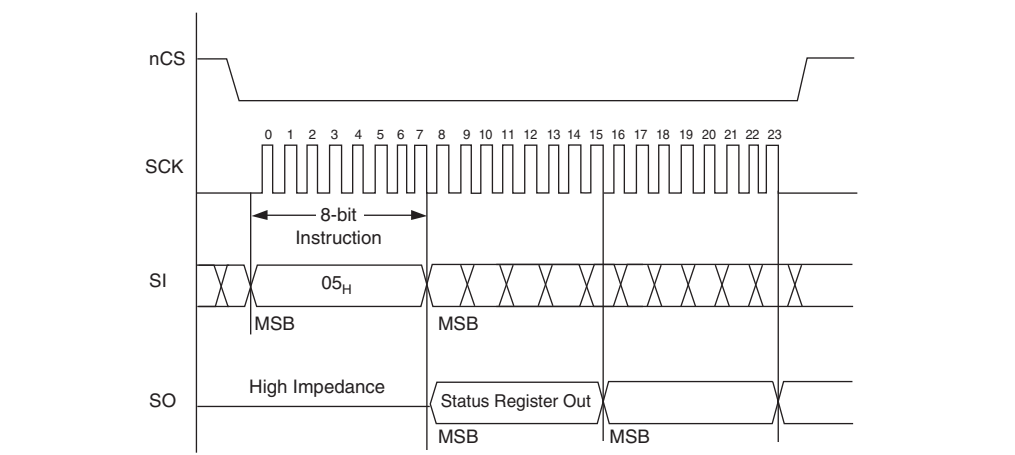

**WRSR (Write Status Register)**

The block protection bits (BP1 and BP0) are the status bits used to protect certain sections of the UFM from inadvertent write. The BP1 and BP0 status are updated by WRSR. During WRSR, only BP1 and BP0 in the status register can be written with valid information. The rest of the bits in the status register are ignored and not updated. When both BP1 and BP0 are 0, there is no protection for the UFM. When both BP1 and BP0 are 1, there is full protection for the UFM. BP0 and BP1 are set to 0 upon power-up. Table 7-12 lists the Block Write Protect Bits for Extended mode, while Table 7-13 lists the Block Write Protect Bits for Base mode. WRSR is issued through the following sequence, as shown in Figure 7-31:

1. nCS is pulled low.
2. Opcode 00000001 is transmitted into the interface.
3. An 8-bit status is transmitted into the interface to update BP1 and BP0 of the status register.
4. If nCS is pulled high too early (before all the eight bits in Step 2 or Step 3 are transmitted) or too late (the ninth bit or more is transmitted), WRSR is not executed.
5. nCS is pulled back to high to terminate the transmission.

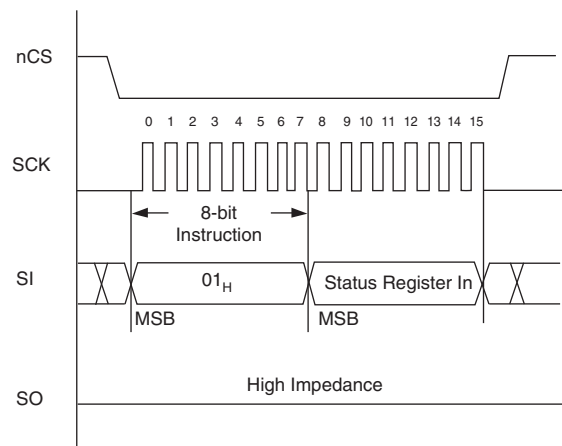
**Figure 7-31. WRSR Operation Sequence****Table 7-12. Block Write Protect Bits for Extended Mode**

Level	Status Register Bits		UFM Array Address Protected
	BP1	BP0	
0 (No protection)	0	0	None
3 (Full protection)	1	1	000 to 1FF

**Table 7-13. Block Write Protect Bits for Base Mode**

Level	Status Register Bits		UFM Array Address Protected
	BP1	BP0	
0 (No protection)	0	0	None
3 (Full protection)	1	1	000 to 0FF

## ALTUFM SPI Timing Specification

Figure 7-32 shows the timing specification needed for the SPI Extended mode (read/write). These nCS timing specifications do not apply to the SPI Extended read-only mode nor to any of the SPI Base modes. However, for the SPI Extended mode (read only) and the SPI Base mode (both read only and read/write), the nCS signal and SCK are not allowed to toggle at the same time. Table 7-14 lists the timing parameters that only apply to the SPI Extended mode (read/write).

Figure 7-32. SPI Timing Waveform

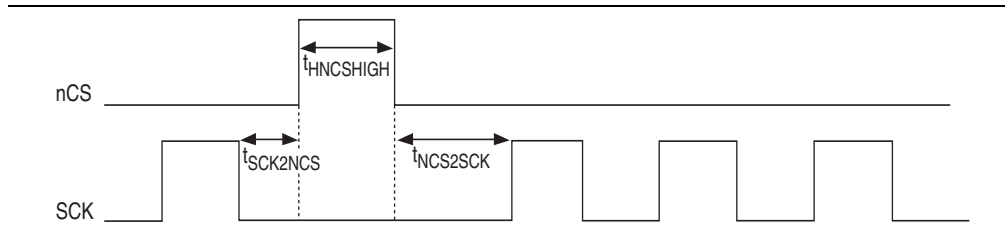

Table 7-14. SPI Timing Parameters for Extended Mode

Symbol	Description	Minimum (ns)	Maximum (ns)
$t_{SCK2NCS}$	The time required for the SCK signal falling edge to nCS signal rising edge	50	—
$t_{HNCSHIGH}$	The time that the nCS signal must be held high	600	—
$t_{NCS2SCK}$	The time required for the nCS signal falling edge to SCK signal rising edge	750	—

## Instantiating SPI Using Quartus II ALTUFM\_SPI Megafunction

Figure 7-33 shows the ALTUFM\_SPI megafunction symbol for SPI instantiation in the Quartus II software.

Figure 7-33. ALTUFM\_SPI Megafunction Symbol for SPI Instantiation

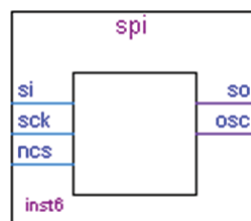

ALTUFM\_SPI megafunction is under the **Memory Compiler** folder on page 2a of the MegaWizard Plug-In Manager. On page 3, you can choose whether to implement the **Read/Write** or **Read Only** mode as the access mode for the UFM. You can also select the configuration mode (Base or Extended) for SPI on this page. You can specify the initial content of the UFM block on page of the ALTUFM MegaWizard Plug-In Manager as discussed in *“Creating Memory Content File”* on page 7-39.



The UFM block’s internal oscillator is always running when the ALTUFM\_SPI megafunction is instantiated for read/write interface. The UFM block’s internal oscillator is disabled when the ALTUFM\_SPI megafunction is instantiated for read only interface.

## Parallel Interface

This interface allows for parallel communication between the UFM block and outside logic. After the READ request, WRITE request, or ERASE request is asserted (active low assertion), the outside logic or device (such as a microcontroller) can continue its operation while the data in the UFM is retrieved, written, or erased. During this time, the nBUSY signal is driven “low” to indicate that it is not available to respond to any further request. After the operation is complete, the nBUSY signal is brought back to “high” to indicate that it is now available to service a new request. If it was the Read request, the DATA\_VALID is driven “high” to indicate that the data at the DO port is the valid data from the last read address.

Asserting READ, WRITE, and ERASE at the same time is not allowed. Multiple requests are ignored and nothing is read from, written to, or erased in the UFM block. There is no support for sequential read and page write in the parallel interface. For both the read only and the read/write modes of the parallel interface, OSC\_ENA is always asserted, enabling the internal oscillator. Table 7-15 lists the parallel interface pins and functions.

**Table 7-15. Parallel Interface Signals**

Pin	Description	Function
DI [15..0]	16-bit data Input	Receive 16-bit data in parallel. You can select an optional width of 3 to 16 bits using the ALTUFM megafunction.
DO [15..0]	16-bit data Output	Transmit 16-bit data in parallel. You can select an optional width of 3 to 16 bits using the ALTUFM megafunction.
ADDR [8..0]	Address Register	Operation sequence refers to the data that is pointed to by the address register. You can determine the address bus width using the ALTUFM megafunction.
nREAD	READ Instruction Signal	Initiates a read sequence.
nWRITE	WRITE Instruction Signal	Initiates a write sequence.
nERASE	ERASE Instruction Signal	Initiates a SECTOR-ERASE sequence indicated by the MSB of the ADDR [] port.
nBUSY	BUSY Signal	Driven low to notify that it is not available to respond to any further request.
DATA_VALID	Data Valid	Driven high to indicate that the data at the DO port is the valid data from the last read address for read request.

Even though the ALTUFM megafunction allows you to select the address widths range from 3 bits to 9 bits, the UFM block always expects a full 9 bits for the width of the address register. Therefore, the ALTUFM megafunction will always pad the remaining LSBs of the address register with '0's if the register width selected is less than 9 bits. The address register will point to sector 0 if the address received at the address register starts with a '0'. The address register will point to sector 1 if the address received starts with a '1'.

Even though you can select an optional data register width of 3 to 16 bits using the ALTUFM megafunction, the UFM block always expects full 16 bits width for the data register. Reading from the data register always proceeds from MSB to LSB. The ALTUFM megafunction always pads the remaining LSBs of the data register with 1s if the user selects a data width of less than 16-bits.

## ALTUFM Parallel Interface Timing Specification

Figure 7-34 shows the timing specifications for the parallel interface. Table 7-16 lists the parallel interface instruction signals. The nREAD, nWRITE, and nERASE signals are active low signals.

Figure 7-34. Parallel Interface Timing Waveform

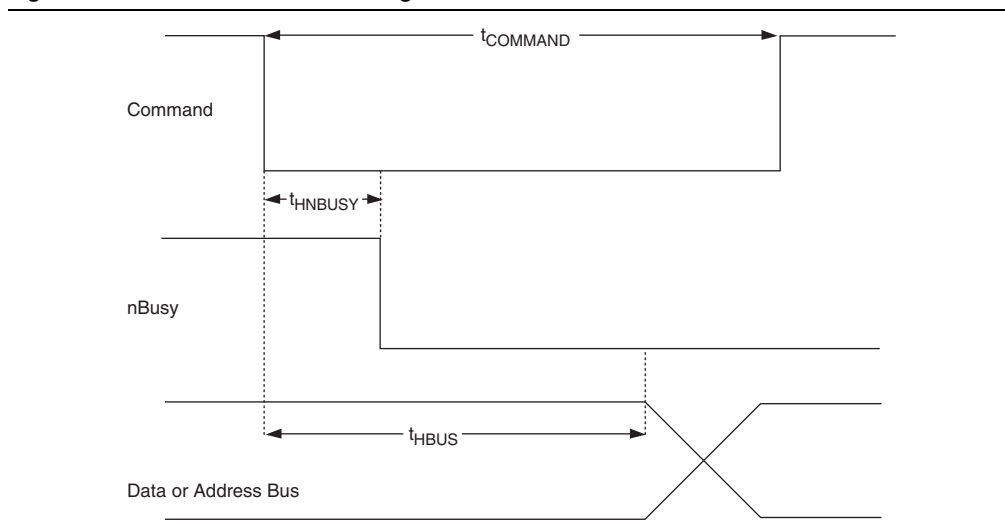

Table 7-16. Parallel Interface Timing Parameters

Symbol	Description	Minimum (ns)	Maximum (ns)
$t_{\text{COMMAND}}$	The time required for the command signal (nREAD/nWRITE/nERASE) to be asserted and held low to initiate a read/write/erase sequence	600	3,000
$t_{\text{HNBUSY}}$	Maximum delay between command signal's falling edge to the nBUSY signal's falling edge	—	300
$t_{\text{HBUS}}$	The time that the data and address buses must be present at the data input and address register ports after the command signal has been asserted low	600	—

## Instantiating Parallel Interface Using Quartus II ALTUFM\_PARALLEL Megafunction

Figure 7-35 shows the ALTUFM\_PARALLEL megafunction symbol for a parallel interface instantiation in the Quartus II software.

Figure 7-35. ALTUFM\_PARALLEL Megafunction Symbol for Parallel Interface Instantiation

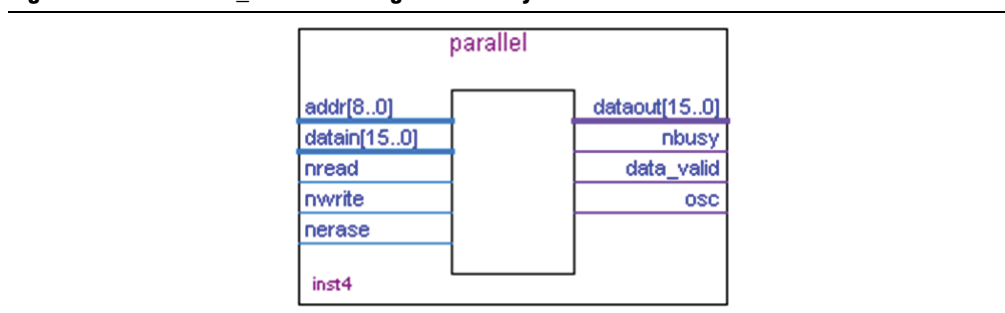

ALTUFM\_PARALLEL megafunction is under the **Memory Compiler** folder on page 2a of the MegaWizard Plug-In Manager. On page 3, you can choose whether to implement the **Read/Write** or **Read Only** mode for the UFM. You also have an option to choose the width for address bus (up to 9 bits) and for the data bus (up to 16 bits). You can specify the initial content of the UFM block on page 4 of the ALTUFM MegaWizard Plug-In Manager as discussed in [“Creating Memory Content File” on page 7-39](#).

 The UFM block’s internal oscillator is always running when the ALTUFM\_PARALLEL megafunction is instantiated for read/write interface. The UFM block’s internal oscillator is disabled when the ALTUFM\_PARALLEL megafunction is instantiated for a read only interface.

## None (Altera Serial Interface)

Select **None** for the interface protocol to use the dedicated UFM serial interface. The built-in UFM interface uses 13 pins for the communication. The functional description of the 13 pins are described in [Table 7-4 on page 7-3](#). You can produce your own interface design to communicate to/from the dedicated UFM interface and implement it in the logic array.

### Instantiating None Using Quartus II ALTUFM\_NONE Megafunction

[Figure 7-36](#) shows the ALTUFM\_NONE megafunction symbol for None instantiation in the Quartus II software.

**Figure 7-36. ALTUFM\_NONE Megafunction Symbol for None Instantiation**

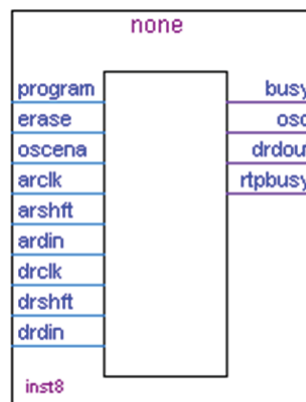

ALTUFM\_NONE megafunction is under the **Memory Compiler** folder on page 2a of the MegaWizard Plug-In Manager. You can specify the initial content of the UFM block on page 3 of the ALTUFM MegaWizard Plug-In Manager as discussed in [“Creating Memory Content File”](#).

## Creating Memory Content File

You can initialize the content of the UFM through a memory content file. The Quartus II software supports two types of initial memory content file format: Memory Initialization File (.mif) and Hexadecimal File (.hex). A new memory content file for the UFM block can be created by clicking **New** on the File menu. Select the .mif or .hex file in the **Other Files** tab.

After clicking **OK**, a dialog box appears. In this dialog box, the **Number of words** represents the numbers of address lines while the **Word size** represents the data width. To create a memory content file for the ALTUFM megafunction, enter 512 for the number of words and 16 for the word size.

The memory content is written into a .hex file. On the Tools menu, click **MegaWizard Plug-In Manager**. The memory content file (**data.hex**) is included on the respective ALTUFM MegaWizard Plug-In Manager. Click **Yes** to use this file for the memory content file. Click **Browse** to include the memory content file.

### Memory Initialization for the ALTUFM\_PARALLEL Megafunction

For the parallel interface, if a .hex file is used to initialize the memory content for the ALTUFM megafunction, you must fully specify all 16 bits in each memory address, regardless of the data width selected. If your data width is less than 16 bits wide, your data must be placed in the MSBs of the data word and the remaining LSBs must be padded with 1's.

For an example, if `address_width = 3` and `data_width = 8` are selected for the ALTUFM\_PARALLEL megafunction, the .hex file should contain eight addresses of data ( $2^3$  addresses), each word containing 16 bits. If the initial content at the location 000 is intended to be 10101010, you should specify 1010101011111111 for address 000 in the .hex file.



This specification applies only to .hex files used with the parallel interface. .mifs do not require you to fully specify 16 bits for each data word. However, both .mif and .hex files require you to specify all addresses of data according to the `address_width` selected in the megafunction.

### Memory Initialization for the ALTUFM\_SPI Megafunction

The same 16-bit data padding mentioned for ALTUFM\_PARALLEL is required for .hex files used with the SPI Base (8 bits) and Extended (16 bits) mode interface. In addition, for SPI Base and Extended modes, you must fully specify memory content for all 512 addresses (both sector 0 and sector 1) in the .mif and .hex files, even if sector 1 is not used. You can put valid data for SPI Base mode addresses 0 to 255 (sector 0), and initialize sector 1 to all ones.

## Memory Initialization for the ALTUFM\_I2C Megafunction

The MAX V UFM physical memory block contains a 16-bit wide and 512 deep (9-bit address) array. The ALTUFM\_I2C megafunction uses the following smaller array sizes:

- An 8-bit wide and 128 deep (7-bit address) mapping for 1 Kbit memory size
- An 8-bit wide and 256 deep (8-bit address) mapping for 2 Kbits memory size
- An 8-bit wide and 512 deep (9-bit address) mapping for 4 Kbits memory size
- An 8-bit wide and 1,024 deep (10-bit address) mapping for 8 Kbits memory size

Altera recommends that you pad the **.mif** or **.hex** file for both address and data width to fill the physical memory map for the UFM block and ensure the **.mif** or **.hex** file represents a full 16-bit word size and a 9-bit address space.

### Memory Map for 1-Kbit Memory Initialization

Figure 7-37 shows the memory map initialization for the ALTUFM\_I2C megafunction of 1-Kbit memory size. The ALTUFM\_I2C megafunction byte address location of 00h to 3Fh is mapped to the UFM block address location of 000h to 03Fh. The ALTUFM\_I2C megafunction byte address location of 40h to 7Fh is mapped to the UFM block address location of 1C0h to 1FFh. Altera recommends that you pad the unused address locations of the UFM block with all 1s.

**Figure 7-37. Memory Map for 1-Kbit Memory Initialization**

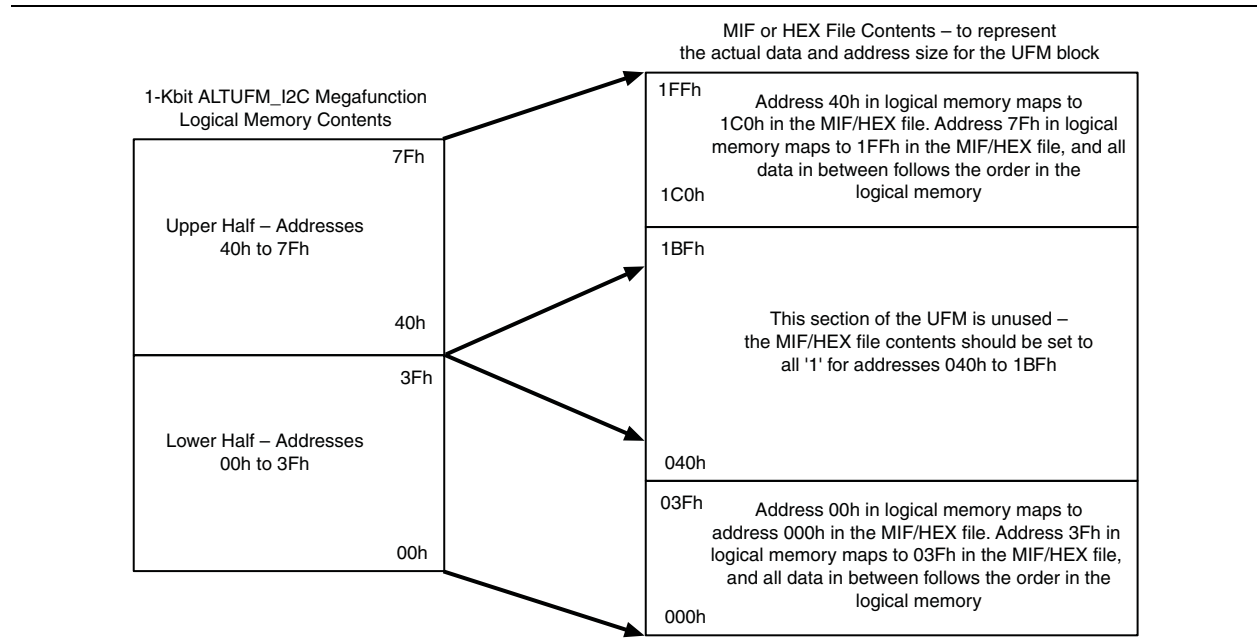

### Memory Map for 2-Kbit Memory Initialization

Figure 7-38 shows the memory map initialization for the ALTUFM\_I2C megafunction of 2 Kbits of memory. The ALTUFM\_I2C megafunction byte address location of 00h to 7Fh is mapped to the UFM block address location of 000h to 07Fh. The ALTUFM\_I2C megafunction byte address location of 80h to FFh is mapped to the UFM block address location of 180h to 1FFh. Altera recommends that you pad the unused address location of the UFM block with all 1s.

Figure 7-38. Memory Map for 2-Kbit Memory Initialization

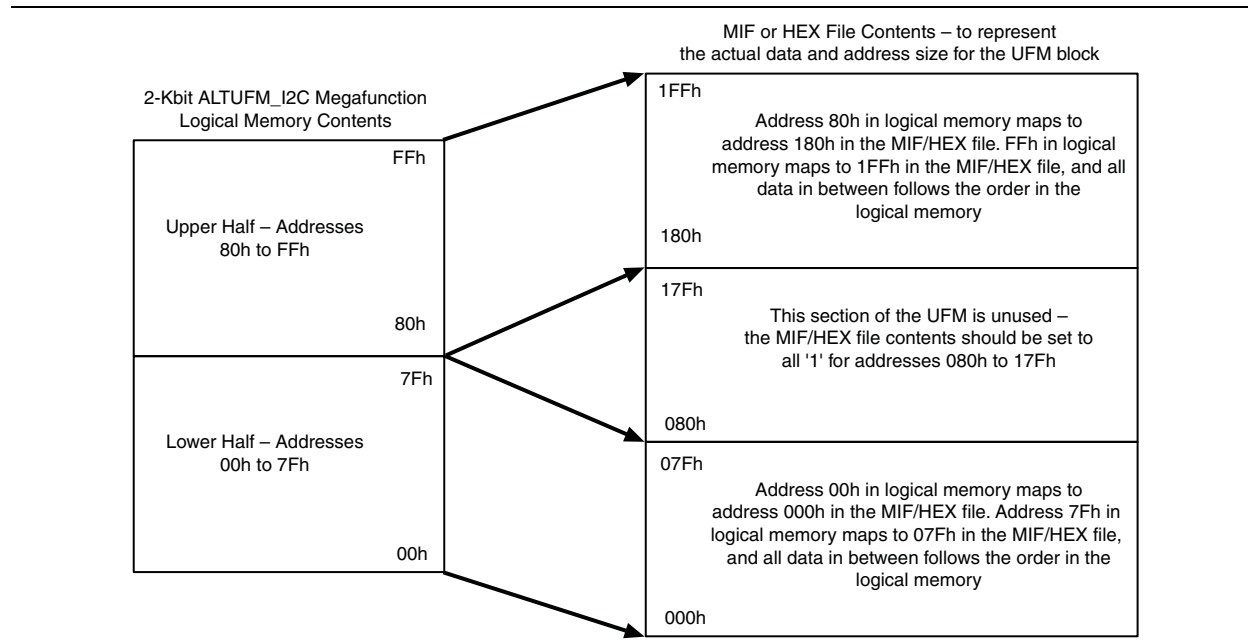

### Memory Map for 4-Kbit Memory Initialization

Figure 7-39 shows the memory map initialization for the ALTUFM\_I2C megafunction of 4-Kbit memory. The ALTUFM\_I2C megafunction byte address location of 00h to FFh is mapped to the UFM block address location of 000h to 0FFh. The ALTUFM\_I2C megafunction byte address location of 100h to 1FFh is mapped to the UFM block address location of 100h to 1FFh.

Figure 7-39. Memory Map for 4-Kbit Memory Initialization

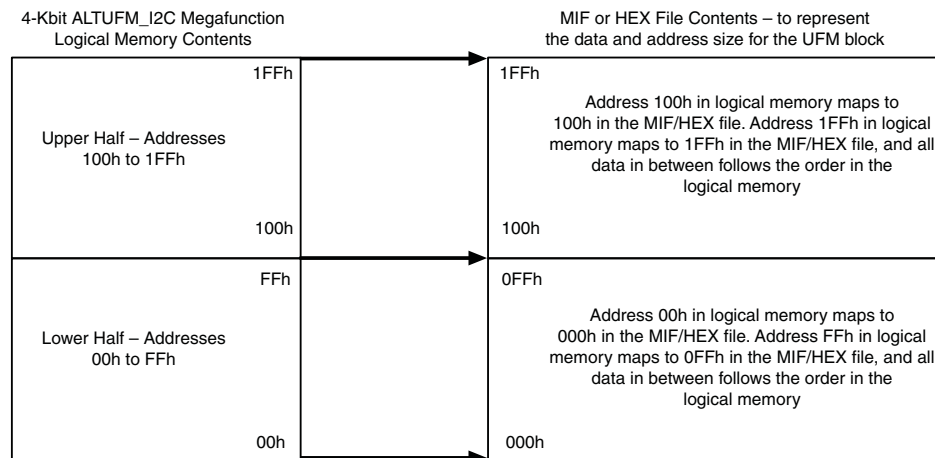

### Memory Map for 8-Kbit Memory Initialization

Figure 7-40 shows the memory map initialization for the ALTUFM\_I2C megafunction of 8-Kbit memory. The ALTUFM\_I2C megafunction of 8-Kbit memory fully utilizes all the memory locations in the UFM block.

Figure 7-40. Memory Map for 8-Kbit Memory Initialization

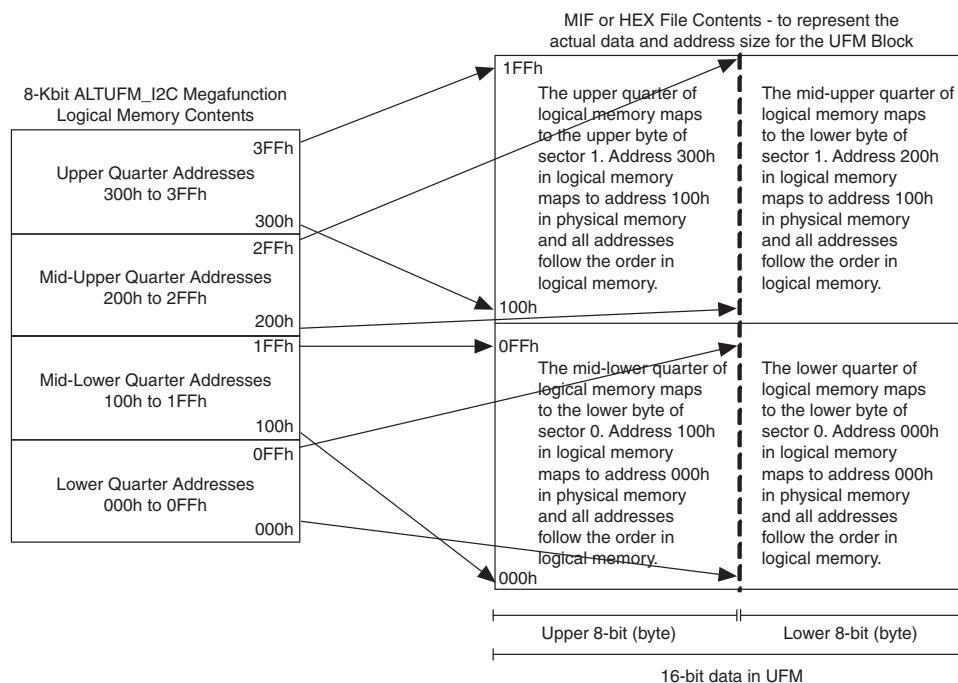

### Padding Data into Memory Map

The ALTUFM\_I2C megafunction uses the upper 8 bits of the UFM 16-bit word; therefore, the 8 least significant bits should be padded with 1s, as shown in [Figure 7-41](#).

**Figure 7-41. Padding Data into Memory Map**

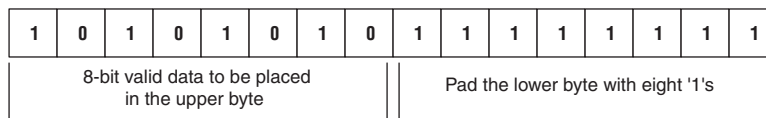

## Simulation Parameters

In the ALTUFM megafunction, you have an option to simulate the OSC output port at the maximum or the minimum frequency during the design simulation. The frequency chosen is only used as the timing parameter for the Quartus II simulator and does not affect the real MAX V device OSC output frequency.

## Document Revision History

[Table 7-17](#) lists the revision history for this chapter.

**Table 7-17. Document Revision History**

Date	Version	Changes
May 2014	1.2	Updated <a href="#">“Page Write Operation”</a> on <a href="#">page 7-17</a>
January 2011	1.1	Updated <a href="#">“Oscillator”</a> section.
December 2010	1.0	Initial release.



This chapter describes the IEEE Std.1149.1 (JTAG) boundary-scan testing for Altera® MAX® V devices. The IEEE Std. 1149.1 BST circuitry available in MAX V devices provides a cost-effective and efficient way to test systems that contain devices with tight lead spacing. Circuit boards with Altera and other IEEE Std. 1149.1-compliant devices can use EXTEST, SAMPLE/PRELOAD, and BYPASS modes to create serial patterns that internally test the pin connections between devices and check device operation.

As PCBs become more complex, the requirement for thorough testing becomes increasingly important. Advances in surface-mount packaging and PCB manufacturing have resulted in smaller boards, making traditional test methods (for example, external test probes and “bed-of-nails” test fixtures) harder to implement. As a result, cost savings from PCB space reductions are sometimes offset by cost increases in traditional testing methods.

In the 1980s, JTAG developed a specification for boundary-scan testing that was later standardized as the IEEE Std. 1149.1 specification. This boundary-scan test (BST) architecture offers the capability to efficiently test components on PCBs with tight lead spacing.

BST architecture can test pin connections without using physical test probes and capture functional data while a device is operating normally. Boundary-scan cells (BSCs) in a device can force signals onto pins, or capture data from pin or core logic signals. Forced test data is serially shifted into the BSCs. Captured data is serially shifted out and externally compared to expected results.

Figure 8–1 shows the concept of boundary-scan testing.

**Figure 8–1. IEEE Std. 1149.1 Boundary-Scan Testing**

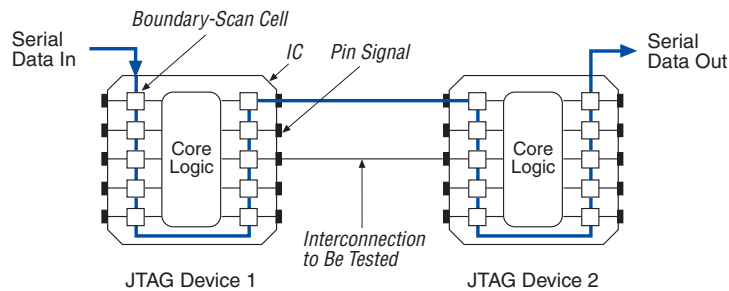

This chapter describes the following topics:

- “IEEE Std. 1149.1 BST Architecture” on page 8–2
- “IEEE Std. 1149.1 Boundary-Scan Register” on page 8–3
- “IEEE Std. 1149.1 BST Operation Control” on page 8–6
- “I/O Voltage Support in the JTAG Chain” on page 8–13
- “Boundary-Scan Test for Programmed Devices” on page 8–14

© 2010 Altera Corporation. All rights reserved. ALTERA, ARRIA, CYCLONE, HARDCOPY, MAX, MEGACORE, NIOS, QUARTUS and STRATIX are Reg. U.S. Pat. & Tm. Off. and/or trademarks of Altera Corporation in the U.S. and other countries. All other trademarks and service marks are the property of their respective holders as described at [www.altera.com/common/legal.html](http://www.altera.com/common/legal.html). Altera warrants performance of its semiconductor products to current specifications in accordance with Altera’s standard warranty, but reserves the right to make changes to any products and services at any time without notice. Altera assumes no responsibility or liability arising out of the application or use of any information, product, or service described herein except as expressly agreed to in writing by Altera. Altera customers are advised to obtain the latest version of device specifications before relying on any published information and before placing orders for products or services.

- “Disabling IEEE Std. 1149.1 BST Circuitry” on page 8–15
- “Guidelines for IEEE Std. 1149.1 Boundary-Scan Testing” on page 8–15
- “Boundary-Scan Description Language Support” on page 8–15

In addition to BST, you can use the IEEE Std. 1149.1 controller for in-system programming for MAX V devices. MAX V devices support IEEE 1532 programming, which uses the IEEE Std. 1149.1 test access port (TAP) interface. However, this chapter only describes the BST feature of the IEEE Std. 1149.1 circuitry.

## IEEE Std. 1149.1 BST Architecture

A MAX V device operating in IEEE Std. 1149.1 BST mode uses four required pins, TDI, TDO, TMS, and TCK.

Table 8–1 lists the functions of each of these pins. MAX V devices do not have a TRST pin.

**Table 8–1. IEEE Std. 1149.1 Pin Descriptions**

Pin	Description	Function
TDI (1)	Test data input	Serial input pin for instructions as well as test and programming data. Data is shifted in on the rising edge of TCK.
TDO	Test data output	Serial data output pin for instructions as well as test and programming data. Data is shifted out on the falling edge of TCK. The pin is tri-stated if data is not being shifted out of the device.
TMS (1)	Test mode select	Input pin that provides the control signal to determine the transitions of the TAP controller state machine. Transitions within the state machine occur at the rising edge of TCK. Therefore, you must set up the TMS before the rising edge of TCK. TMS is evaluated on the rising edge of TCK.
TCK (2)	Test clock input	The clock input to the BST circuitry. Some operations occur at the rising edge, while others occur at the falling edge.

**Notes to Table 8–1:**

- (1) The TDI and TMS pins have internal weak pull-up resistors.
- (2) The TCK pin has an internal weak pull-down resistor.

The IEEE Std. 1149.1 BST circuitry requires the following registers:

- The instruction register determines which action to perform and which data register to access.
- The bypass register (which is a 1-bit long data register) provides a minimum-length serial path between the TDI and TDO pins.
- The boundary-scan register that is a shift register composed of all the BSCs of the device.

Figure 8-2 shows a functional model of the IEEE Std. 1149.1 circuitry.

Figure 8-2. IEEE Std. 1149.1 Circuitry

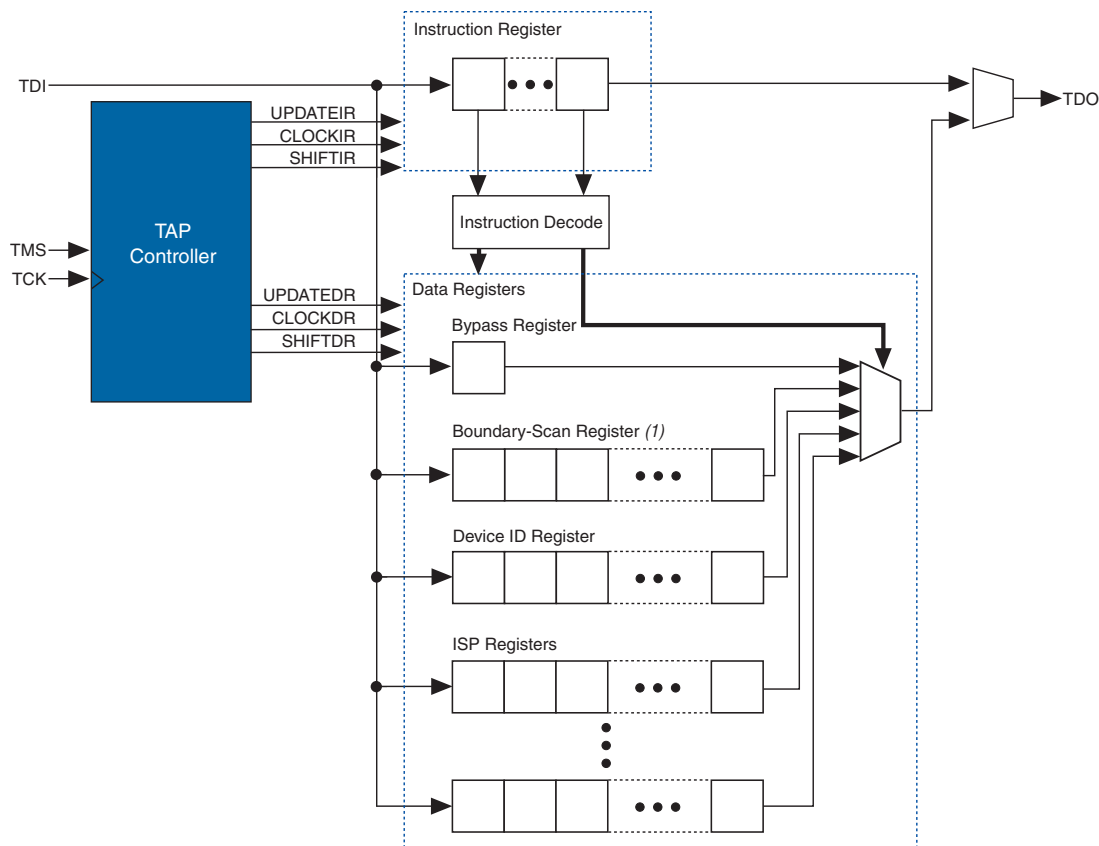

**Note to Figure 8-2:**

(1) For the boundary-scan register length in MAX V devices, refer to the *JTAG and In-System Programmability in MAX V Devices* chapter.

The TAP controller controls the IEEE Std. 1149.1 boundary-scan testing, as described in “IEEE Std. 1149.1 BST Operation Control” on page 8-6. The TMS and TCK pins operate the TAP controller and the TDI and TDO pins provide the serial path for the data registers. The TDI pin also provides data to the instruction register, which then generates the control logic for the data registers.

## IEEE Std. 1149.1 Boundary-Scan Register

The boundary-scan register is a large serial shift register that uses the TDI pin as an input and the TDO pin as an output. The boundary-scan register consists of 3-bit peripheral elements that are associated with the I/O pins of the MAX V devices. You can use the boundary-scan register to test the external pin connections or to capture internal data.



Figure 8-4 shows the user I/O BSC for MAX V devices.

Figure 8-4. User I/O BSC with IEEE Std. 1149.1 BST Circuitry for MAX V Devices

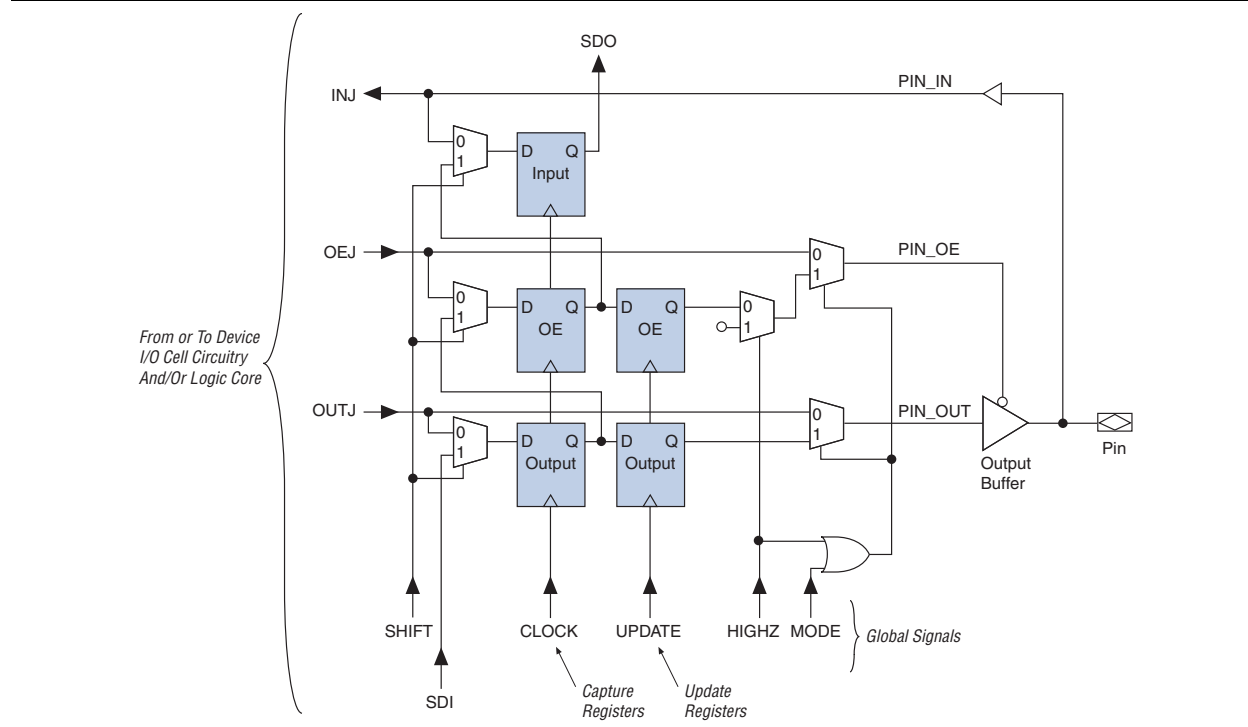

Table 8-2 lists the capture and update register capabilities of all BSC within MAX V devices.

Table 8-2. BSC Description for MAX V Devices (Note 1)

Pin Type	Captures			Drives			Notes
	Output Capture Register	OE Capture Register	Input Capture Register	Output Update Register	OE Update Register	Input Update Register	
User I/O	OUTJ	OEJ	PIN_IN	PIN_OUT	PIN_OE	—	Includes user clocks

Note to Table 8-2:

- (1) TDI, TDO, TMS, and TCK pins and all VCC and GND pin types do not have BSCs.

## JTAG Pins and Power Pins

MAX V devices do not have BSCs for dedicated JTAG pins (TDI, TDO, TMS, and TCK) and power pins (VCCINT, VCCIO, GNDINT, and GNDIO).

## IEEE Std. 1149.1 BST Operation Control

MAX V devices implement the SAMPLE/PRELOAD, EXTEST, BYPASS, IDCODE, USERCODE, CLAMP and HIGHZ IEEE Std. 1149.1 BST instructions. The length of the BST instructions is 10 bits. These instructions are described in detail later in this chapter.

For a summary of the BST instructions and their instruction codes, refer to the *JTAG and In-System Programmability in MAX V Devices* chapter.

The IEEE Std. 1149.1 TAP controller, a 16-state state machine clocked on the rising edge of TCK, uses the TMS pin to control IEEE Std. 1149.1 operation in the device.

Figure 8-5 shows the TAP controller state machine.

**Figure 8-5. IEEE Std. 1149.1 TAP Controller State Machine**

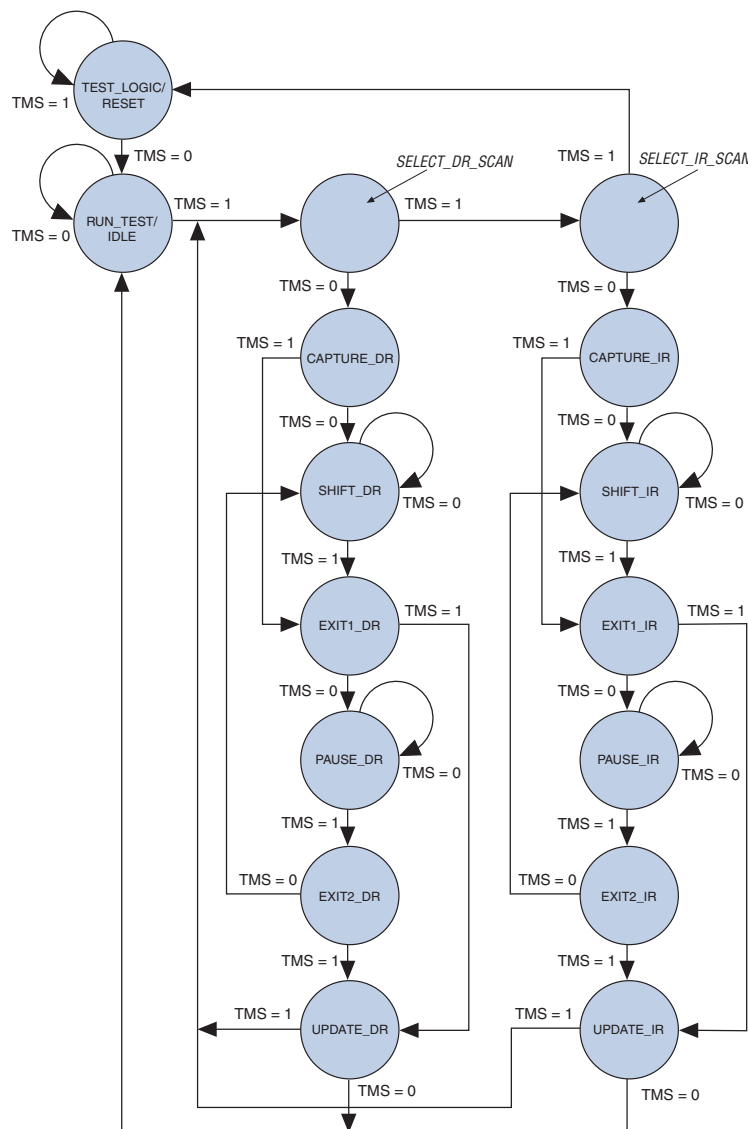

When the TAP controller is in the TEST\_LOGIC/RESET state, the BST circuitry is disabled, the device is in normal operation, and the instruction register is initialized with IDCODE as the initial instruction. During device power up, the TAP controller starts in this TEST\_LOGIC/RESET state. In addition, the TAP controller may be forced to the TEST\_LOGIC/RESET state by holding TMS high for five TCK clock cycles. After the TEST\_LOGIC/RESET state, the TAP controller remains in this state as long as TMS continues to be held high while TCK is clocked.

Figure 8-6 shows the timing requirements for the IEEE Std. 1149.1 signals.

**Figure 8-6. IEEE Std. 1149.1 Timing Waveforms (Note 1)**

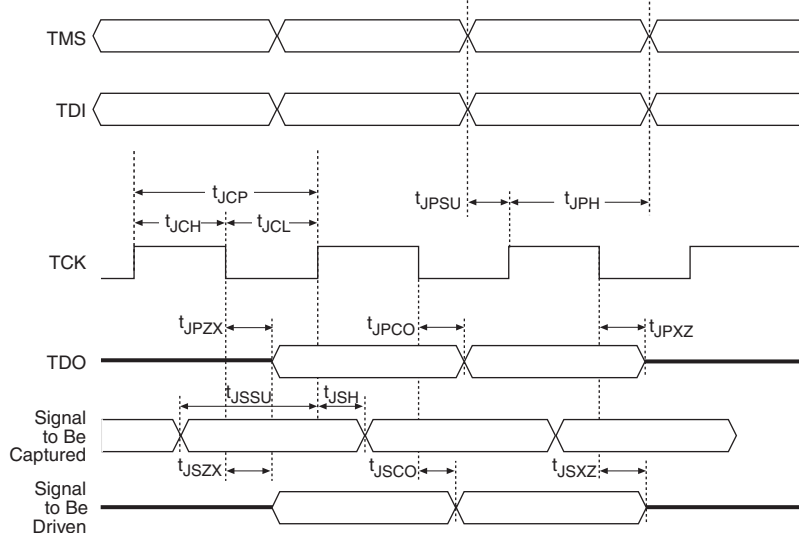

**Note to Figure 8-6:**

(1) For timing parameter values, refer to the *DC and Switching Characteristics for MAX V Devices* chapter.

To start the IEEE Std. 1149.1 operation, select an instruction mode by advancing the TAP controller to the shift instruction register (SHIFT\_IR) state and shift in the appropriate instruction code on the TDI pin.

Figure 8-7 shows the entry of the instruction code into the instruction register. From the RESET state, TMS is clocked with the pattern 01100 to advance the TAP controller to SHIFT\_IR state.

**Figure 8-7. Selecting the Instruction Mode**

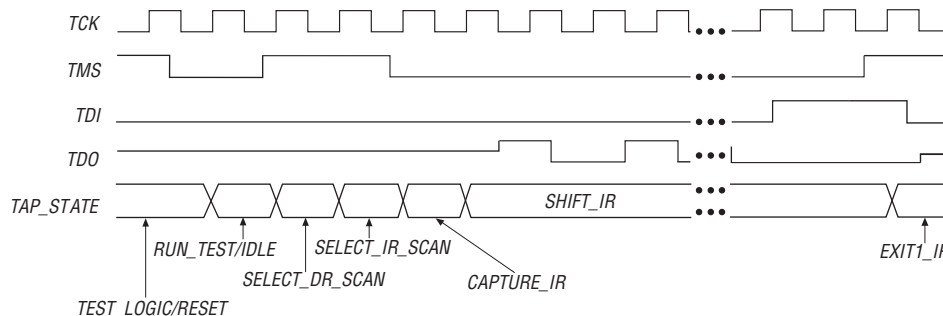

The TDO pin is tri-stated in all states except the `SHIFT_IR` and `SHIFT_DR` states. The TDO pin is activated at the first falling edge of TCK after entering either of the shift states and is tri-stated at the first falling edge of TCK after leaving either of the shift states.

When the `SHIFT_IR` state is activated, TDO is no longer tri-stated, and the initial state of the instruction register is shifted out on the falling edge of TCK. TDO continues to shift out the contents of the instruction register as long as the `SHIFT_IR` state is active. The TAP controller remains in the `SHIFT_IR` state as long as TMS remains low.

During the `SHIFT_IR` state, an instruction code is entered by shifting data on the TDI pin on the rising edge of TCK. You must clock the last bit of the `OPCODE` at the same time that the next state, `EXIT1_IR`, is activated; `EXIT1_IR` is entered by clocking a logic high on TMS. After in the `EXIT1_IR` state, TDO becomes tri-stated again. TDO is always tri-stated except in the `SHIFT_IR` and `SHIFT_DR` states. After an instruction code is entered correctly, the TAP controller advances to perform the serial shifting of test data in one of three modes (`SAMPLE/PRELOAD`, `EXTEST`, or `BYPASS`).

For MAX V devices, there are weak pull-up resistors for TDI and TMS, and pull-down resistors for TCK. However, in a JTAG chain, there might be some devices that do not have internal pull-up or pull-down resistors. In this case, Altera recommends pulling the TMS pin high (through an external 10-k $\Omega$  resistor), and pulling TCK low (through an external 1-k $\Omega$  resistor) during BST or in-system programmability (ISP) to prevent the TAP controller from going into an unintended state. Pulling-up the TDI signal externally for the MAX V device is optional.



For more information about the pull-up and pull-down resistors, refer to [AN 100: In-System Programmability Guidelines](#).

## SAMPLE/PRELOAD Instruction Mode

`SAMPLE/PRELOAD` instruction mode allows you to take a snapshot of device data without interrupting normal device operation. However, `SAMPLE/PRELOAD` instruction mode is most often used to preload the test data into the update registers before loading the `EXTEST` instruction.

During the capture phase, multiplexers preceding the capture registers select the active device data signals and clocked data into the capture registers. The multiplexers at the outputs of the update registers also select active device data to prevent functional interruptions to the device.

During the shift phase, the boundary-scan shift register is formed by clocking data through capture registers around the device periphery and then out of the TDO pin. New test data can simultaneously be shifted into TDI and replace the contents of the capture registers. During the update phase, data in the capture registers is transferred to the update registers. You can then use this data in `EXTEST` instruction mode. For more information, refer to [“EXTEST Instruction Mode” on page 8–10](#).

Figure 8-8 shows the capture, shift, and update phases of SAMPLE/PRELOAD mode.

Figure 8-8. IEEE Std. 1149.1 BST SAMPLE/PRELOAD Mode

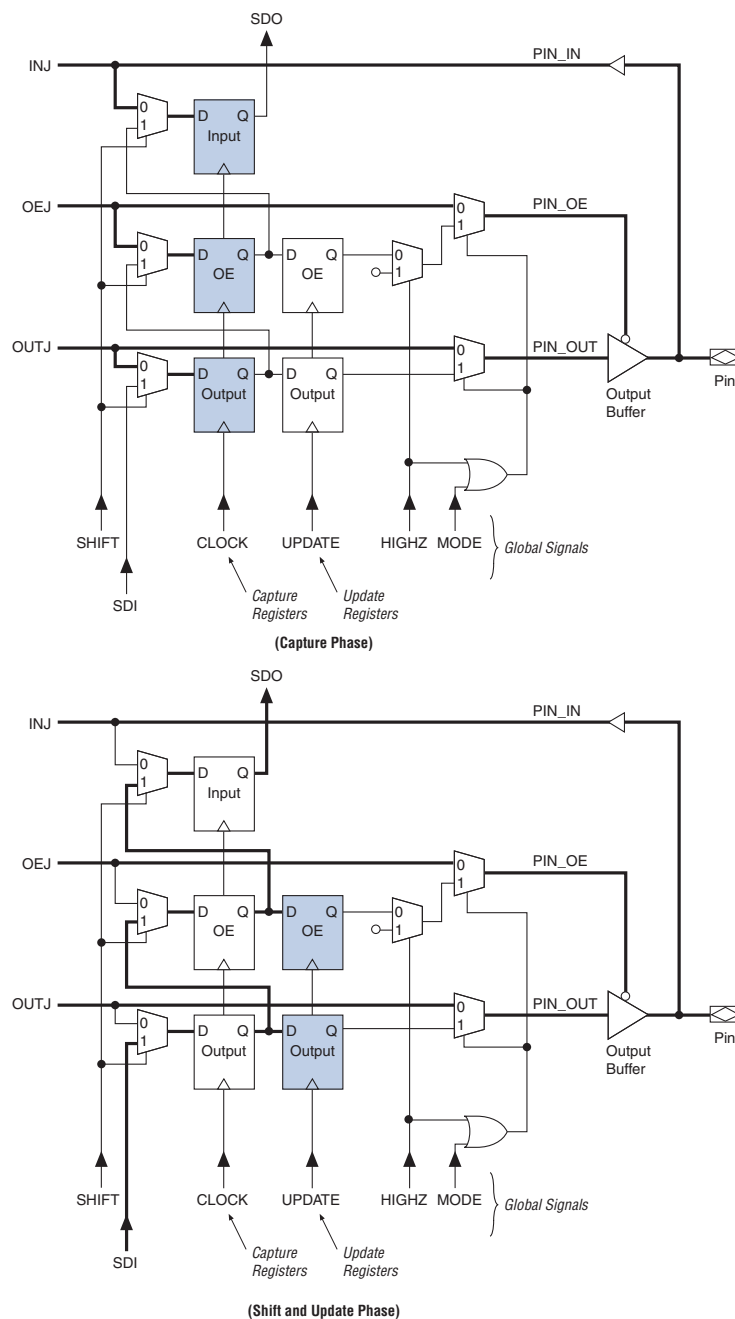

SAMPLE/PRELOAD instruction code shifts in through the TDI pin. The TAP controller advances to the CAPTURE\_DR state and then to the SHIFT\_DR state, where it remains if TMS is held low. The data shifted out of the TDO pin consists of the data that was present in the capture registers after the capture phase. New test data shifted into the TDI pin appears at the TDO pin after being clocked through the entire boundary-scan register.

Figure 8-9 shows that the test data that shifted into TDI does not appear at the TDO pin until after the capture register data that is shifted out. If TMS is held high on two consecutive TCK clock cycles, the TAP controller advances to the UPDATE\_DR state for the update phase.

If you enable the device output enable feature but the DEV\_OE pin is not asserted during boundary-scan testing, the output enable boundary-scan registers of the BSCs capture data from the core of the device during SAMPLE/PRELOAD. These values are not high impedance, although the I/O pins are tri-stated.

Figure 8-9 shows the SAMPLE/PRELOAD waveforms.

**Figure 8-9. SAMPLE/PRELOAD Shift Data Register Waveforms**

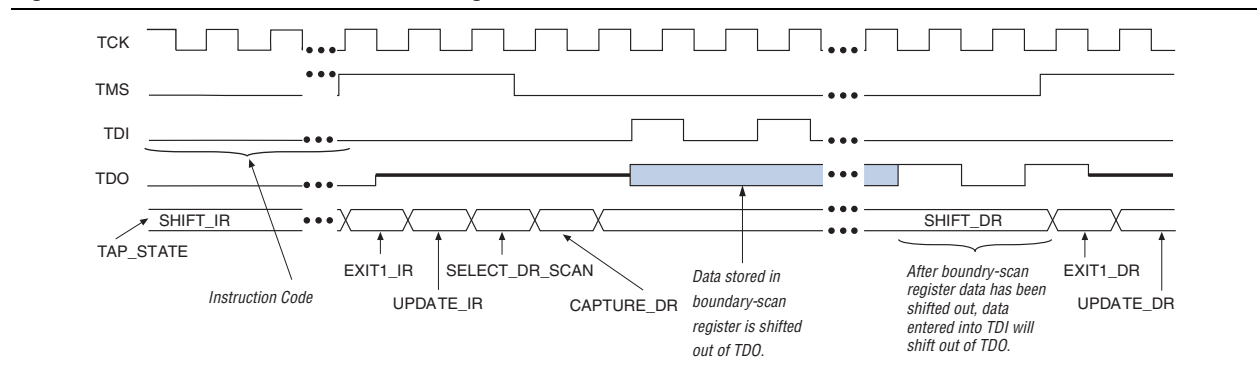

## EXTEST Instruction Mode

Use EXTEST instruction mode to check the external pin connections between devices. Unlike SAMPLE/PRELOAD mode, EXTEST allows test data to be forced onto the pin signals. By forcing known logic high and low levels on output pins, you can detect opens and shorts at pins of any device in the scan chain.

EXTEST selects data differently than SAMPLE/PRELOAD. EXTEST chooses data from the update registers as the source of the output and output enable signals. After the EXTEST instruction code is entered, the multiplexers select the update register data; thus, you can force the data stored in these registers from a previous EXTEST or SAMPLE/PRELOAD test cycle onto the pin signals. In the capture phase, the results of this test data are stored in the capture registers and then shifted out of TDO during the shift phase. You can store the new test data in the update registers during the update phase.

Figure 8-10 shows the capture, shift, and update phases of EXTEST mode.

Figure 8-10. IEEE Std. 1149.1 BST EXTEST Mode

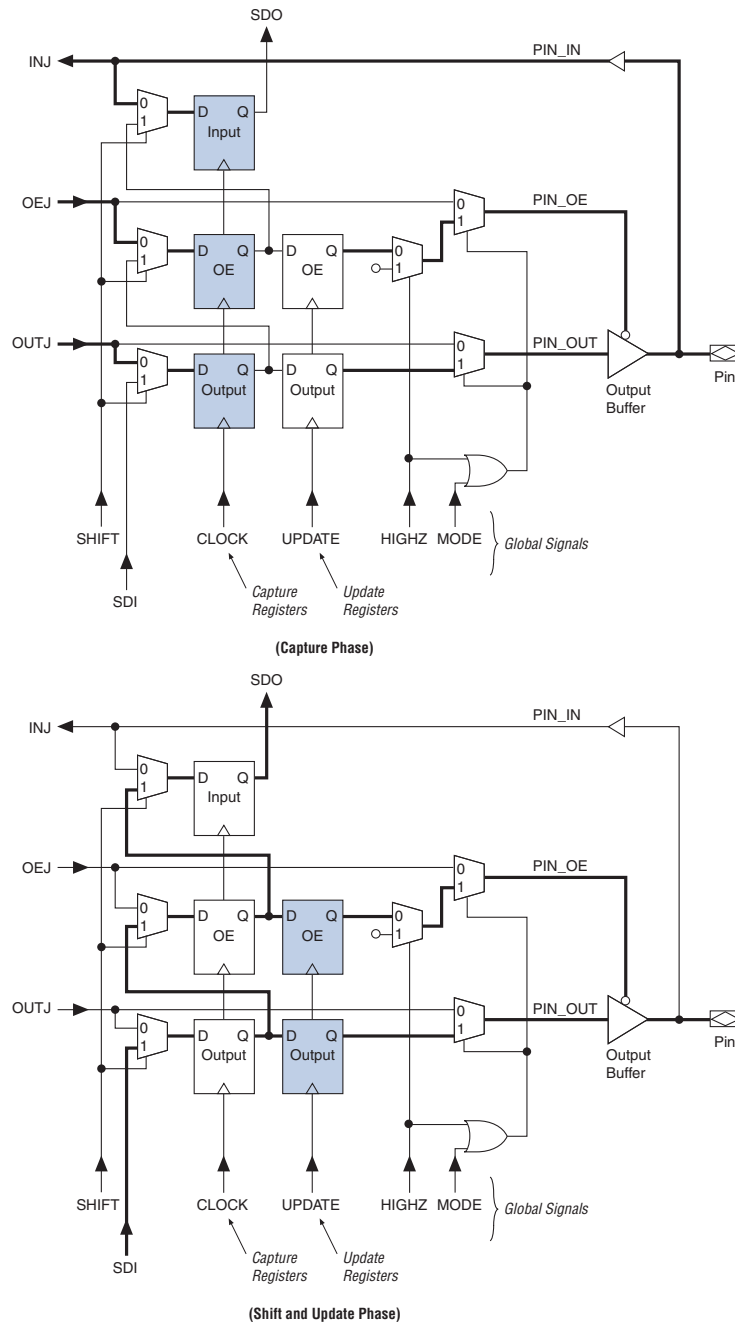
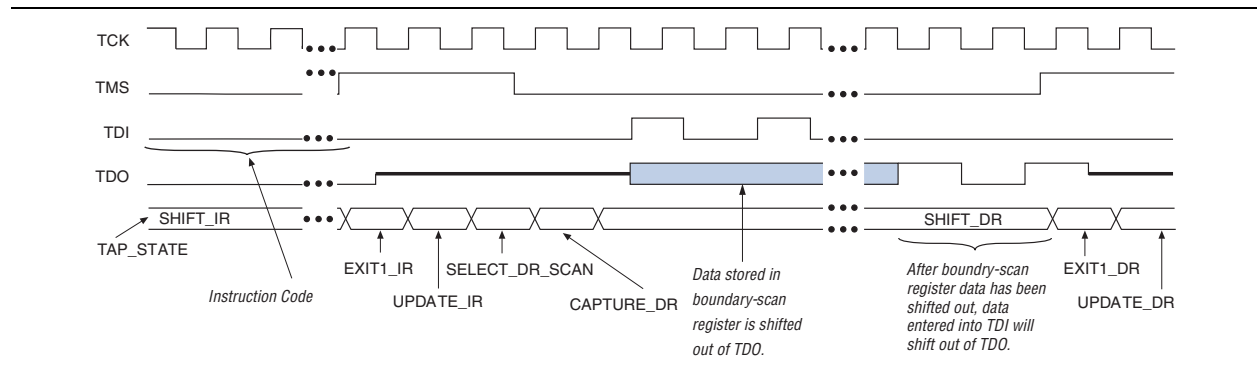

Figure 8-11 resembles the SAMPLE/PRELOAD waveform diagram, except that the instruction code for EXTEST is different. The data shifted out of TDO consists of the data that was present in the capture registers after the capture phase. New test data shifted into the TDI pin appears at the TDO pin after being clocked through the entire boundary-scan register.

**Figure 8-11. EXTEST Shift Data Register Waveforms**



## BYPASS Instruction Mode

You can activate BYPASS instruction mode with an instruction code made up of only ones. Figure 8-12 shows how scan data passes through a device after the TAP controller is in the SHIFT\_DR state. In this state, data signals are clocked into the bypass register from TDI on the rising edge of TCK and out of TDO on the falling edge of the same clock pulse.

**Figure 8-12. BYPASS Shift Data Register Waveforms**

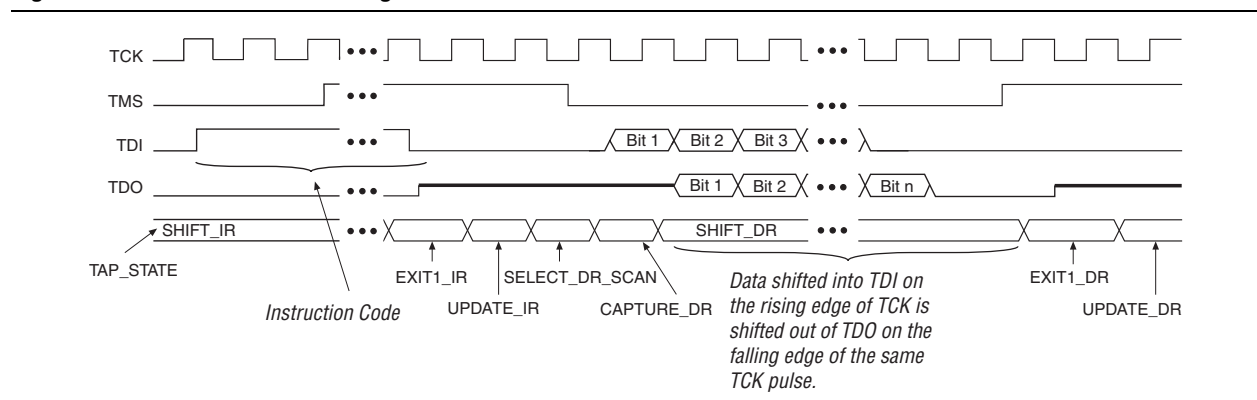

## IDCODE Instruction Mode

Use IDCODE instruction mode to identify the devices in an IEEE Std. 1149.1 chain. When you select IDCODE, the device identification register loads with the 32-bit vendor-defined identification code. The device ID register is connected between the TDI and TDO ports and the device IDCODE is shifted out.

 IDCODE instruction mode for MAX V devices are listed in the *JTAG and In-System Programmability in MAX V Devices* chapter.

## USERCODE Instruction Mode

Use USERCODE instruction mode to examine the user electronic signature (UES) within the devices along an IEEE Std. 1149.1 chain. When you select this instruction, the device identification register is connected between the TDI and TDO ports. The user-defined UES shifts into the device ID register in parallel from the 32-bit USERCODE register. The UES then shifts out through the device ID register. The USERCODE information is only available after the device is successfully configured.

Non-volatile USERCODE data is written to the configuration flash memory (CFM) block and then written to the SRAM at power up. The USERCODE instruction reads the data values from the SRAM. When you use real-time ISP to update the CFM block and write new USERCODE data, executing the USERCODE instruction returns the USERCODE of the current running design (stored in the SRAM), not the new USERCODE data. The USERCODE of the new design (stored in the CFM) can only be read back correctly if a power cycle or forced SRAM download has transpired after the real-time ISP update.

In the Quartus® II software, there is an Auto Usercode feature where you can choose to use the checksum value of a programming file as the JTAG user code. If selected, the checksum is automatically loaded to the USERCODE register.

To enable the Auto Usercode feature, follow these steps:

1. On the Assignments menu, click **Device**.
2. In the Device dialog box, click **Device and Pin Options** and click the General tab.
3. Turn on **Auto Usercode**.

## CLAMP Instruction Mode

Use CLAMP instruction mode to allow the state of the signals driven from the pins to be determined from the boundary-scan register while the bypass register is selected as the serial path between the TDI and TmV51008 . fMDO ports. Data held in the boundary-scan register completely defines the state of all signals driven from the output pins. However, CLAMP instruction mode will not override the I/O weak pull-up resistor or the I/O bus hold if you have any of them selected.

## HIGHZ Instruction Mode

Use HIGHZ instruction mode to set all of the user I/O pins to an inactive drive state. These pins are tri-stated until you execute a new JTAG instruction. When you select this instruction, the bypass register is connected between the TDI and TDO ports. HIGHZ instruction mode will not override the I/O weak pull-up resistor or I/O bus hold if you have any of them selected.

## I/O Voltage Support in the JTAG Chain

There can be several different Altera or non-Altera devices in a JTAG chain. However, you must pay attention to whether or not the chain contains devices with different  $V_{CCIO}$  levels. The TDO pin of a device drives out at the voltage level according to the  $V_{CCIO}$  of the device. For MAX V devices, the TDO pin drives out at the voltage level according to the  $V_{CCIO}$  of I/O Bank 1. Although the devices may have different  $V_{CCIO}$

levels, the devices can interface with each other. For example, a device with 3.3-V  $V_{CCIO}$  can drive to a device with 5.0-V  $V_{CCIO}$  because 3.3 V meets the minimum  $V_{IH}$  on transistor-to-transistor logic (TTL)-level input for the 5.0-V  $V_{CCIO}$  device. JTAG pins on MAX V devices can support 1.5-, 1.8-, 2.5-, or 3.3-V input levels, depending on the  $V_{CCIO}$  voltage of I/O Bank 1.

 For more information about MultiVolt I/O support, refer to the *MAX V Device Architecture* chapter.

You can interface the TDI and TDO lines of the JTAG pins of devices that have different  $V_{CCIO}$  levels by inserting a level shifter between the devices. If possible, the JTAG chain must be built such that a device with a higher  $V_{CCIO}$  level drives to a device with an equal or lower  $V_{CCIO}$  level. By building the JTAG chain in this manner, a level shifter may be required only to shift the TDO level to a level acceptable to the JTAG tester.

Figure 8–13 shows the JTAG chain of mixed voltages and how a level shifter is inserted in the chain.

**Figure 8–13. JTAG Chain of Mixed Voltages**

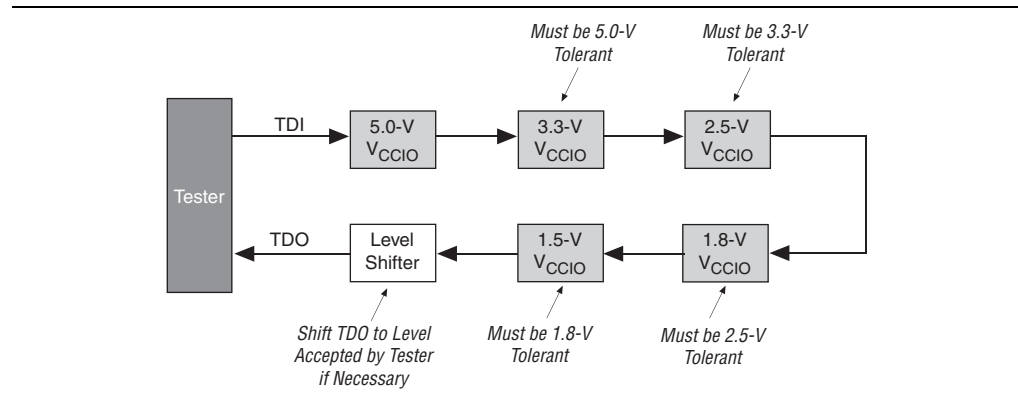

## Boundary-Scan Test for Programmed Devices

For a programmed device, the input buffers are turned off by default for I/O pins that are set as output only in the design file. You cannot sample on the programmed device output pins with the default boundary-scan description language (BSDL) file when the input buffers are turned off.

For boundary-scan testing, you can set the Quartus II software to always enable the input buffers on a programmed device so it behaves the same as an unprogrammed device, allowing sample function on output pins in the design. This aspect can cause slight increase in standby current as the unused input buffer is always on.

To enable the unused input buffers on a programmed device, follow these steps:

1. On the Assignments menu, click **Settings**.
2. Under **Category**, select **Assembler**.
3. Turn on **Always Enable Input Buffers**.

## Disabling IEEE Std. 1149.1 BST Circuitry

You can enable the IEEE Std. 1149.1 BST circuitry for MAX V devices after device powers up. You must enable this circuitry only if you use the BST or ISP features. This section describes how to disable the IEEE Std. 1149.1 circuitry to ensure that the circuitry is not inadvertently enabled when it is not required.

Table 8-3 lists the pin connections necessary for disabling JTAG in MAX V devices that have dedicated IEEE Std. 1149.1 pins.

**Table 8-3. Disabling IEEE Std. 1149.1 Circuitry for MAX V Devices**

JTAG Pins (1)			
TMS	TCK	TDI	TDO
VCC (2)	GND (3)	VCC (2)	Leave Open

**Notes to Table 8-3:**

- (1) There is no software option to disable JTAG in MAX V devices. The JTAG pins are dedicated.
- (2) VCC refers to V<sub>CCIO</sub> of Bank 1.
- (3) The TCK signal may also be tied high. If TCK is tied high, power-up conditions must ensure that TMS is pulled high before TCK. Pulling TCK low avoids this power-up condition.

## Guidelines for IEEE Std. 1149.1 Boundary-Scan Testing

When performing boundary-scan testing with IEEE Std. 1149.1 devices, use the following guidelines:

- If a pattern (for example, a 10-bit 1010101010 pattern) does not shift out of the instruction register through the TDO pin during the first clock cycle of the SHIFT\_IR state, the proper TAP controller state has not been reached. To solve this problem, try one of the following procedures:
  - Verify that the TAP controller has reached the SHIFT\_IR state correctly. To advance the TAP controller to the SHIFT\_IR state, return to the RESET state and clock the code 01100 on the TMS pin.
  - Check the connections to the VCC, GND, and JTAG pins on the device.
- Perform a SAMPLE/PRELOAD test cycle before the first EXTEST test cycle to ensure that known data is present at the device pins when EXTEST mode is entered. If the OEJ update register contains a 0, the data in the OUTJ update register will be driven out. The state must be known and correct to avoid contention with other devices in the system.
- Do not perform EXTEST and SAMPLE/PRELOAD tests during ISP. These instructions are supported before and after ISP but not during ISP.



If problems persist, contact [Technical Support](#).

## Boundary-Scan Description Language Support

The BSDL—a subset of VHDL—provides a syntax that allows you to describe the features of an IEEE Std. 1149.1 BST-capable device that can be tested. Test software development systems then use the BSDL files for test generation, analysis, failure diagnostics, and in-system programming.



For more information, or to receive BSDL files for IEEE Std. 1149.1-compliant MAX V devices, refer to the [IEEE 1149.1 BSDL Files](#) page on the Altera website.

## Document Revision History

Table 8-4 shows the revision history for this chapter.

**Table 8-4. Document Revision History**

Date	Version	Changes
December 2010	1.0	Initial release.

This chapter provides additional information about the document and Altera.

## Document Revision History

The following table shows the revision history for this document.

Date	Version	Changes
January 2011	1.1	Updated MAX V Device Family Overview, DC and Switching Characteristics for MAX V Devices, and User Flash Memory in MAX V Devices chapters.
December 2010	1.0	Initial release.

## How to Contact Altera

To locate the most up-to-date information about Altera® products, refer to the following table.

Contact (1)	Contact Method	Address
Technical support	Website	<a href="http://www.altera.com/support">www.altera.com/support</a>
Technical training	Website	<a href="http://www.altera.com/training">www.altera.com/training</a>
	Email	<a href="mailto:custrain@altera.com">custrain@altera.com</a>
Product literature	Website	<a href="http://www.altera.com/literature">www.altera.com/literature</a>
Non-technical support (General) (Software Licensing)	Email	<a href="mailto:nacomp@altera.com">nacomp@altera.com</a>
	Email	<a href="mailto:authorization@altera.com">authorization@altera.com</a>







**Note to Table:**

(1) You can also contact your local Altera sales office or sales representative.

## Typographic Conventions

The following table shows the typographic conventions this document uses.

Visual Cue	Meaning
<b>Bold Type with Initial Capital Letters</b>	Indicate command names, dialog box titles, dialog box options, and other GUI labels. For example, <b>Save As</b> dialog box. For GUI elements, capitalization matches the GUI.
<b>bold type</b>	Indicates directory names, project names, disk drive names, file names, file name extensions, software utility names, and GUI labels. For example, <b>\qdesigns</b> directory, <b>D:</b> drive, and <b>chiptrip.gdf</b> file.
<i>Italic Type with Initial Capital Letters</i>	Indicate document titles. For example, <i>Stratix IV Design Guidelines</i> .
<i>italic type</i>	Indicates variables. For example, $n + 1$ . Variable names are enclosed in angle brackets (< >). For example, <file name> and <project name>.pdf file.

Visual Cue	Meaning
Initial Capital Letters	Indicate keyboard keys and menu names. For example, the Delete key and the Options menu.
“Subheading Title”	Quotation marks indicate references to sections within a document and titles of Quartus II Help topics. For example, “Typographic Conventions.”
Courier type	Indicates signal, port, register, bit, block, and primitive names. For example, <code>data1</code> , <code>tdi</code> , and <code>input</code> . The suffix <code>n</code> denotes an active-low signal. For example, <code>resetn</code> . Indicates command line commands and anything that must be typed exactly as it appears. For example, <code>c:\qdesigns\tutorial\chiptrip.gdf</code> . Also indicates sections of an actual file, such as a Report File, references to parts of files (for example, the AHDL keyword <code>SUBDESIGN</code> ), and logic function names (for example, <code>TRI</code> ).
	An angled arrow instructs you to press the Enter key.
1., 2., 3., and a., b., c., and so on	Numbered steps indicate a list of items when the sequence of the items is important, such as the steps listed in a procedure.
	Bullets indicate a list of items when the sequence of the items is not important.
	The hand points to information that requires special attention.
?	A question mark directs you to a software help system with related information.
	The feet direct you to another document or website with related information.
 CAUTION	A caution calls attention to a condition or possible situation that can damage or destroy the product or your work.
 WARNING	A warning calls attention to a condition or possible situation that can cause you injury.
	The envelope links to the <a href="#">Email Subscription Management Center</a> page of the Altera website, where you can sign up to receive update notifications for Altera documents.

# Mouser Electronics

Authorized Distributor

Click to View Pricing, Inventory, Delivery & Lifecycle Information:

[Altera:](#)

[5M240ZT144A5N](#) [5M160ZM100I5N](#) [5M160ZM100A5N](#) [5M80ZE64C5N](#) [5M80ZT100A5N](#) [5M240ZM100C5N](#)  
[5M570ZT100A5N](#) [5M2210ZF256C4N](#) [5M1270ZF256I5N](#) [5M40ZE64I5N](#) [5M80ZM68C4N](#) [5M160ZT100C5N](#)  
[5M570ZT144I5N](#) [5M240ZM68C5N](#) [5M160ZM68I5N](#) [5M2210ZF324I5N](#) [5M570ZM100C4N](#) [5M160ZE64C4N](#)  
[5M570ZM100I5N](#) [5M160ZE64I5N](#) [5M240ZT100C4N](#) [5M2210ZF324A5N](#) [5M240ZT100I5N](#) [5M40ZE64C5N](#)  
[5M570ZT144C5N](#) [5M80ZE64C4N](#) [5M40ZM64C4N](#) [5M160ZM68C5N](#) [5M570ZT100I5N](#) [5M160ZT100C4N](#)  
[5M240ZT144I5N](#) [5M2210ZF256I5N](#) [5M570ZM100A5N](#) [5M1270ZF256C5N](#) [5M80ZM68C5N](#) [5M2210ZF324C4N](#)  
[5M160ZT100A5N](#) [5M1270ZF256C4N](#) [5M570ZT144C4N](#) [5M80ZT100C5N](#) [5M160ZE64C5N](#) [5M570ZF256A5N](#)  
[5M2210ZF256C5N](#) [5M80ZM64C5N](#) [5M1270ZF256A5N](#) [5M80ZT100C4N](#) [5M240ZT144C4N](#) [5M80ZE64I5N](#)  
[5M240ZT100C5N](#) [5M160ZM100C4N](#) [5M1270ZT144I5N](#) [5M570ZF256I5N](#) [5M240ZM68I5N](#) [5M40ZE64C4N](#)  
[5M80ZM64I5N](#) [5M570ZT100C5N](#) [5M2210ZF256I5](#) [5M240ZM100C4N](#) [5M160ZM68A5N](#) [5M570ZT144A5N](#)  
[5M1270ZT144C5N](#) [5M240ZM100A5N](#) [5M240ZT100A5N](#) [5M2210ZF324C5N](#) [5M80ZM68I5N](#) [5M80ZM64C4N](#)  
[5M80ZM68A5N](#) [5M570ZF256C4N](#) [5M40ZM64C5N](#) [5M160ZM68C4N](#) [5M240ZM68A5N](#) [5M1270ZT144A5N](#)  
[5M2210ZF256A5N](#) [5M80ZM64A5N](#) [5M40ZM64I5N](#) [5M240ZM100I5N](#) [5M570ZF256C5N](#) [5M40ZE64A5N](#)  
[5M80ZE64A5N](#) [5M1270ZT144C4N](#) [5M80ZT100I5N](#) [5M1270ZF324C5N](#) [5M1270ZF324C4N](#) [5M160ZE64A5N](#)  
[5M240ZM68C4N](#) [5M160ZM100C5N](#) [5M240ZT144C5N](#) [5M1270ZF324I5N](#) [5M570ZM100C5N](#) [5M160ZT100I5N](#)  
[5M1270ZF324A5N](#) [5M570ZT100C4N](#) [5M40ZM64A5N](#) [5M1270ZT144I5](#) [5M570ZE64I5N](#)

## Looking for pricing, stock, or lifecycle information?

Click below to explore more details on WIN SOURCE:

 [View 5M240ZM68C4N on WIN SOURCE](#)

 [Intel Information](#)

## Optimize Your Supply Chain with WIN SOURCE Solutions

-  Global Sourcing Solution
-  Obsolete Management
-  Cost Control Management
-  Shortage Management
-  Alternative Solution
-  Excess Inventory Management