



THE DATASHEET OF LM2696EVAL



AN-1410 LM2696 Demonstration Board

1 Introduction

The LM2696 is a constant on-time, buck regulator capable of delivering up to 3A into a load.

The LM2696 is capable of switching frequencies in the range of 100 kHz to 500 kHz and accepts input voltages from 4.5 V to 24 V. An internal soft-start and power-good flag are also provided to allow for simple sequencing between multiple regulators.

The operating conditions for the evaluation board are the following:

$$V_{IN} = 6 \text{ V to } 24 \text{ V}$$

$$V_{OUT} = 2.5 \text{ V}$$

$$I_{OUT} = 0 \text{ A to } 3 \text{ A}$$

$$f_{SW} = 250 \text{ kHz}$$

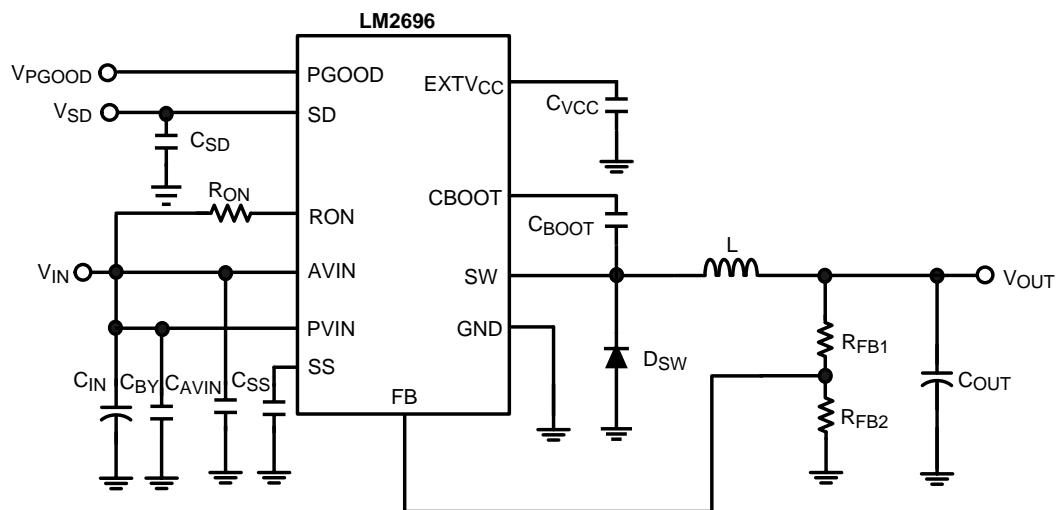

Figure 1. Evaluation Board Schematic

Table 1. Bill of Materials (BOM)

ID	Part Number	Type	Size	Parameters	Qty	Vendor
U1	LM2696	3A Constant on-time Regulator	HTSSOP-16		1	TI
L	MSS1260-682MX	Inductor	MSS1260	6.8 μ H, 4.9A ISAT	1	Coilcraft
C _{IN}	EEUFC1V181	Capacitor	8 x 11.5	180 μ F, 35 V	1	Sanyo
C _{BY}	VJ0805Y104KXAM	Capacitor	0805	0.1 μ F	1	Vishay
C _{SS}	VJ080JY103KXX	Capacitor	0805	0.01 μ F	1	Vishay
C _{VCC}	VJ0805Y105JXACW1BC	Capacitor	0805	1 μ F	1	Vishay
C _{BOOT}	VJ0805Y104KXAM	Capacitor	0805	0.1 μ F	1	Vishay
C _{AVIN}	VJ0805Y105JXACW1BC	Capacitor	0805	1 μ F	1	Vishay

All trademarks are the property of their respective owners.

Table 1. Bill of Materials (BOM) (continued)

ID	Part Number	Type	Size	Parameters	Qty	Vendor
C _{OUT}	TPSW476M010R0150	Capacitor	W	47 μF, 10 V, 150 mΩ	1	AVX
C _{SD}	VJ0805Y102KXXA	Capacitor	0805	1 nF	1	Vishay
R _{FB1}	CRCW08051001F	Resistor	0805	1 kΩ	1	Vishay
R _{FB2}	CRCW08051001F	Resistor	0805	1 kΩ	1	Vishay
R _{ON}	CRCW08051433F	Resistor	0805	143 kΩ	1	Vishay
D _{SW}	CMSH3-40M-NST	Schottky Diode	SMB	40 V @ 3A diode, V _F = 0.55 V	1	Central Semiconductor
160-1026-02 -05-00	Solder Terminals		Terminals for V _{IN} , GND and V _{OUT}		7	Wearnes

2 Performance

Benchmark data has been taken from the evaluation board using the LM2696. Figure 2 shows an efficiency measurement taken with V_{IN} at 12 V.

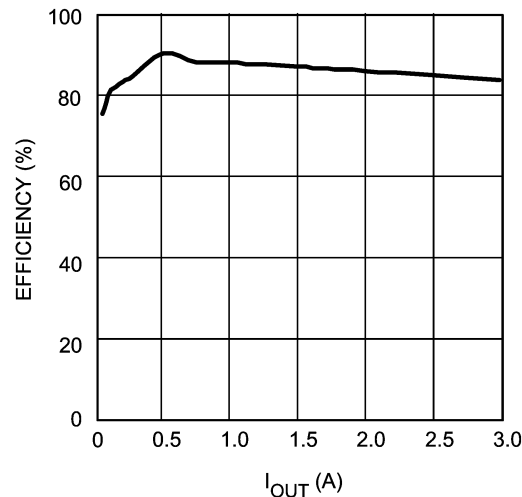
Figure 2. Efficiency with V_{IN} = 12 V

The advantage of the evaluation board is the ability to examine performance tradeoffs through substitution of parts. By careful selection of the components used, it is possible to optimize the application circuit for a given parameter. For instance, the inductor footprint has been designed to accommodate DO-3316 and MSS-1278 packages. The inductor selection would then be determined by the design constraints.

3 Frequency Selection

The resistor connected to the R_{ON} pin sets the switching frequency of the LM2696. This resistor controls the current flowing into the R_{ON} pin and is directly related to the on-time pulse. Connecting a resistor from this pin to PV_{IN} allows the switching frequency to remain constant as the input voltage changes. In normal operation this pin is approximately 0.65 V above GND. In shutdown, this pin becomes a high impedance node to prevent current flow.

The value of R_{ON} may be expressed as:

$$R_{ON} = \frac{(V_{IN} - V_D) \times V_{OUT}}{k_{ON} \times f_{SW} \times V_{IN}} \times 10^6 \quad (1)$$

Where R_{ON} is in kΩ, f_{SW} is in kHz, and k_{ON} is in μA • μs

Under no condition should a bypass capacitor be connected to the R_{ON} pin. Doing so couples any AC perturbations into the pin and prevents proper operation.

For this demo board, R_{ON} is calculated as :

$$R_{ON} = \frac{(12V - 0.65V) \times 2.5V}{66 \mu A \times \mu s \times 250 \text{ kHz} \times 12V} 10^6 = 143 \text{ k}\Omega \quad (2)$$

4 Inductor Selection

Typically an inductor is selected such that the maximum peak-to-peak ripple current is less than 30% of the maximum load current. The inductor current ripple (ΔI_L) may be expressed as:

$$\Delta I_L = \frac{(V_{IN} - V_{OUT}) \cdot D}{L \cdot f_{SW}} \quad (3)$$

The inductor for this demo board was calculated as shown in [Equation 4](#):

$$L = \frac{(12V - 2.5V) \times 0.21V}{(40\% \times 3A) \times 250 \text{ kHz}} 10^3 = 6.8 \mu H \quad (4)$$

A standard value of 10 μH may be chosen.

The other characteristics of the inductor that should be taken into account are saturation current and core material. A shielded inductor or low profile unshielded inductor is recommended to reduce EMI.

Physical orientation of the inductor effects the parts stability. The inductor should be oriented such that the magnetic flux flows down through the center of the inductor and returns through the ground plane. Simply put, the inductor should be oriented such that terminal associated with the dot or label is connected to the switchnode.

5 Output Capacitor

The output capacitor size and ESR have a direct affect on the stability of the loop. This is because the constant on-time control scheme works by sensing the output voltage ripple and switching appropriately.

The ripple voltage necessary at the feedback pin may be estimated using the following relationship:

$$\Delta V_{FB} \geq 0.057 \times f_{SW} + 35 \quad (5)$$

Where f_{SW} is in kHz and ΔV_{FB} is in mV.

This minimum ripple voltage is necessary in order for the comparator to initiate switching.

The ripple at the output may be calculated by multiplying the feedback ripple voltage by the gain seen through the feedback resistors. This gain H may be expressed as:

$$H = \frac{V_{OUT}}{V_{FB}} = \frac{2.5V}{1.25V} \quad (6)$$

For this demo board, the ripple necessary at the feedback pin is calculated as:

$$\Delta V_{FB} 21 \text{ mV} \geq 0.057 \times 250 \text{ kHz} + 35 \quad (7)$$

Therefore, the ripple at the output is:

$$\Delta V_{OUT} = 42 \text{ mV} = 21 \text{ mV} \times \frac{2.5V}{1.25V} \quad (8)$$

Since the ripple current is calculated as 798 mA, the output capacitor must have an ESR not less than:

$$ESR = 36 \text{ m}\Omega = \frac{\text{Ripple_Voltage}}{\text{Ripple_Current}} = \frac{42 \text{ mV}}{1200 \text{ mA}} \quad (9)$$

Typically the best performance is obtained using POSCAPs, SP CAPs, tantalum, Niobium Oxide, or similar chemistry type capacitors. Low ESR ceramic capacitors may be used in conjunction with the RC feed forward scheme; however, the feed forward voltage at the feedback pin must greater than 30 mV. For more information, see [Section 6](#).

6 Ripple Feed Forward

An RC network may be used to eliminate the need for high ESR capacitors. Such a network is connected as shown in Figure 3.

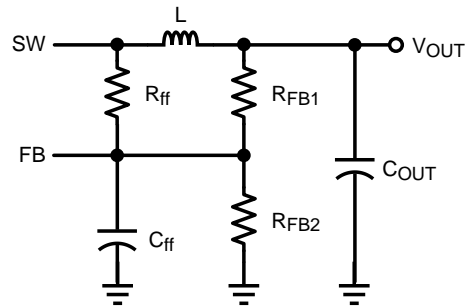

Figure 3. RC Feed Forward Network

The value of R_{ff} should be large in order to prevent any potential offset in V_{OUT} . Typically the value of R_{ff} is on the order of $1M\Omega$ and the value of R_{FB1} should be less than $10k\Omega$. The large difference in resistor values minimizes output voltage offset errors in DCM. The value of the capacitor may be selected using the following relationship:

$$C_{ff_MAX} = \frac{(V_{IN_MIN} - V_{FB}) \cdot T_{ON_MIN}}{0.03V \cdot R_{ff}} \quad (10)$$

Where the on-time (T_{ON_MIN}) is in μs , and the resistance (R_{ff}) is in $M\Omega$.

If a ceramic output capacitor is used with this demo board, C_{ff_MAX} is calculated as:

$$C_{ff_MAX} = \frac{(6V - 1.25V) \times 0.42 \mu s}{0.03V \times 1 M\Omega} = 67 \text{ pF} \quad (11)$$

A standard value of 270 pF may be chosen.

7 Feedback Resistors

In order to reduce noise at the feedback pin, R_{FB2} is typically on the order of $1k\Omega$. To calculate the value of R_{FB1} , one may use the relationship:

$$R_{FB1} = R_{FB2} \left(\frac{V_{OUT}}{V_{FB}} - 1 \right) \quad (12)$$

Where V_{FB} is the internal reference voltage (1.255 V typical).

The output voltage value can be set in a precise manner by taking into account the fact that the reference voltage is regulating the bottom of the output ripple as opposed to the average value. This relationship is shown in Figure 4.

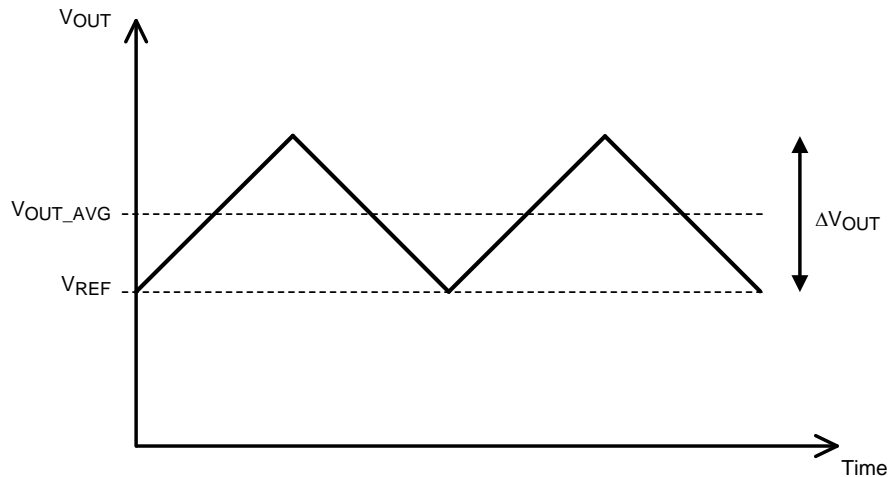

Figure 4. Average and Ripple Output Voltages

One should note that for high output voltages (>5 V), a load of approximately 15mA may be required for the output voltage to reach the desired value.

The resistors for this demo board were selected as: $R_{FB2} = 1\text{k}\Omega$

$$R_{FB1} = 1\text{k}\Omega \left(\frac{2.5\text{V}}{1.25\text{V}} - 1 \right) = 1\text{k}\Omega \quad (13)$$

8 Soft-Start Capacitor

The SS capacitor is used to slowly ramp the reference from 0 V to its final value of 1.25 V. The startup time may be calculated using [Equation 14](#):

$$t_{SS} = \frac{1.25\text{V} \times C_{SS}}{I_{SS}} \times 10^{-3} \quad (14)$$

or conversely, capacitance as a function of startup time:

$$C_{SS} = I_{SS} \frac{t_{SS}}{1.25\text{V}} \times 10^{-3} \quad (15)$$

Where I_{SS} is the soft-start pin source current (1 μA typical) in μA , C_{SS} is in μF , and t_{SS} is in ms.

The soft-start capacitor was selected such that the soft start time would be approximately 12.5 ms. The capacitor value was calculated as:

$$C_{SS} = 0.01\ \mu\text{F} = 1\ \mu\text{A} \frac{12.5\text{ms}}{1.25\text{V}} \times 10^{-3} \quad (16)$$

9 Shutdown

The state of the shutdown pin enables the device or places it in a sleep state. This pin has an internal pull-up and may be left floating or connected to a high logic level. Connecting this pin to GND will shutdown the part. This pin must be bypassed with a 1nF ceramic capacitor to ensure proper logic thresholds.

10 Layout Guidelines

Good layout for DC-DC converters can be implemented by following a few simple design guidelines:

1. Place the power components (catch diode, inductor, and filter capacitors) close together. Make the traces between them as short and wide as possible.
2. Use wide traces between the power components and for power connections to the DC-DC converter circuit.

3. Connect the ground pins of the input and output filter capacitors and catch diode as close as possible using generous component-side copper fill as a pseudo-ground plane. Then, connect this to the ground plane through several vias.
4. Arrange the power components so that the switching loops curl in the same direction.
5. Separate noise sensitive traces, such as the voltage feedback path, from noisy traces associated with the power components.
6. Ensure a low-impedance ground for the converter IC.
7. Place the supporting components for the converter IC, including frequency selection components as close to the converter IC as possible, but away from noisy traces and the power components. Make their connections to the converter IC and its pseudoground plane as short as possible.
8. Place noise sensitive circuitry such as radio or modem blocks away from the DC-DC converter.

11 PCB Layouts

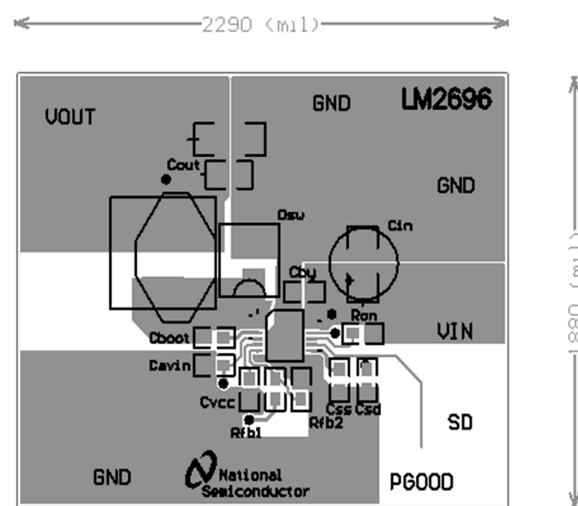

Figure 5. Top Layer

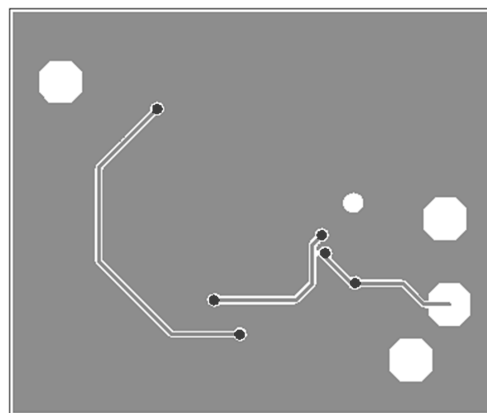

Figure 6. Bottom Layer

12 Alternate Application Circuit

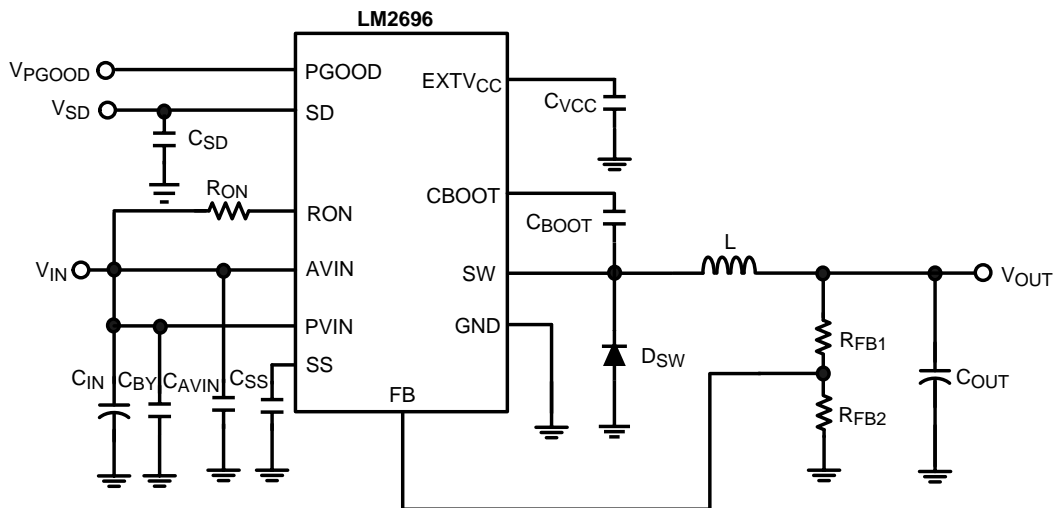

Figure 7. 5 V to 2.5 V Voltage Applications Circuit

ID	Part Number	Type	Size	Parameters	Qty	Vendor
U1	LM2696	3A Constant on-time Regulator	HTSSOP-16		1	NSC
L	MSS1260-103MX	Inductor	MSS1260	10 μ H, 4.0A ISAT	1	Coilcraft
C _{IN}	EEUFC1V181	Capacitor	10 x 12.5	180 μ F, 35 V, 90 m Ω	1	Panasonic
C _{BY}	VJ0805Y104KXAM	Capacitor	0805	0.1 μ F	1	Vishay
C _{SS}	VJ0805Y103KXX	Capacitor	0805	0.01 μ F	1	Vishay
C _{VCC}	VJ0805Y105JXACW1BC	Capacitor	0805	1 μ F	1	Vishay
C _{BOOT}	VJ0805Y104KXAM	Capacitor	0805	0.1 μ F	1	Vishay
C _{AVIN}	VJ0805Y105JXACW1BC	Capacitor	0805	1 μ F	1	Vishay
C _{OUT}	TPSC107M006R0075	Capacitor	C	100 μ F, 6 V, 75 m Ω	1	AVX
C _{SD}	VJ0805Y102KXXA	Capacitor	0805	1 nF	1	Vishay
R _{FB1}	CRCW08051651F	Resistor	0805	1.65 k Ω	1	Vishay
R _{FB2}	CRCW08051001F	Resistor	0805	1 k Ω	1	Vishay
R _{ON}	CRCW08051543F	Resistor	0805	154 k Ω	1	Vishay
D _{SW}	CMSH3-40M-NST	Schottky Diode	SMB	40 V @ 3A diode, VF = 0.55 V	1	Central Semiconductor
160-1026-02-05-00	Solder Terminals		Terminals for V _{IN} , GND and V _{OUT}		7	Wearnes

IMPORTANT NOTICE

Texas Instruments Incorporated and its subsidiaries (TI) reserve the right to make corrections, enhancements, improvements and other changes to its semiconductor products and services per JESD46, latest issue, and to discontinue any product or service per JESD48, latest issue. Buyers should obtain the latest relevant information before placing orders and should verify that such information is current and complete. All semiconductor products (also referred to herein as "components") are sold subject to TI's terms and conditions of sale supplied at the time of order acknowledgment.

TI warrants performance of its components to the specifications applicable at the time of sale, in accordance with the warranty in TI's terms and conditions of sale of semiconductor products. Testing and other quality control techniques are used to the extent TI deems necessary to support this warranty. Except where mandated by applicable law, testing of all parameters of each component is not necessarily performed.

TI assumes no liability for applications assistance or the design of Buyers' products. Buyers are responsible for their products and applications using TI components. To minimize the risks associated with Buyers' products and applications, Buyers should provide adequate design and operating safeguards.

TI does not warrant or represent that any license, either express or implied, is granted under any patent right, copyright, mask work right, or other intellectual property right relating to any combination, machine, or process in which TI components or services are used. Information published by TI regarding third-party products or services does not constitute a license to use such products or services or a warranty or endorsement thereof. Use of such information may require a license from a third party under the patents or other intellectual property of the third party, or a license from TI under the patents or other intellectual property of TI.

Reproduction of significant portions of TI information in TI data books or data sheets is permissible only if reproduction is without alteration and is accompanied by all associated warranties, conditions, limitations, and notices. TI is not responsible or liable for such altered documentation. Information of third parties may be subject to additional restrictions.

Resale of TI components or services with statements different from or beyond the parameters stated by TI for that component or service voids all express and any implied warranties for the associated TI component or service and is an unfair and deceptive business practice. TI is not responsible or liable for any such statements.

Buyer acknowledges and agrees that it is solely responsible for compliance with all legal, regulatory and safety-related requirements concerning its products, and any use of TI components in its applications, notwithstanding any applications-related information or support that may be provided by TI. Buyer represents and agrees that it has all the necessary expertise to create and implement safeguards which anticipate dangerous consequences of failures, monitor failures and their consequences, lessen the likelihood of failures that might cause harm and take appropriate remedial actions. Buyer will fully indemnify TI and its representatives against any damages arising out of the use of any TI components in safety-critical applications.

In some cases, TI components may be promoted specifically to facilitate safety-related applications. With such components, TI's goal is to help enable customers to design and create their own end-product solutions that meet applicable functional safety standards and requirements. Nonetheless, such components are subject to these terms.

No TI components are authorized for use in FDA Class III (or similar life-critical medical equipment) unless authorized officers of the parties have executed a special agreement specifically governing such use.

Only those TI components which TI has specifically designated as military grade or "enhanced plastic" are designed and intended for use in military/aerospace applications or environments. Buyer acknowledges and agrees that any military or aerospace use of TI components which have **not** been so designated is solely at the Buyer's risk, and that Buyer is solely responsible for compliance with all legal and regulatory requirements in connection with such use.

TI has specifically designated certain components as meeting ISO/TS16949 requirements, mainly for automotive use. In any case of use of non-designated products, TI will not be responsible for any failure to meet ISO/TS16949.

Products

Audio	www.ti.com/audio
Amplifiers	amplifier.ti.com
Data Converters	dataconverter.ti.com
DLP® Products	www.dlp.com
DSP	dsp.ti.com
Clocks and Timers	www.ti.com/clocks
Interface	interface.ti.com
Logic	logic.ti.com
Power Mgmt	power.ti.com
Microcontrollers	microcontroller.ti.com
RFID	www.ti-rfid.com
OMAP Applications Processors	www.ti.com/omap
Wireless Connectivity	www.ti.com/wirelessconnectivity

Applications

Automotive and Transportation	www.ti.com/automotive
Communications and Telecom	www.ti.com/communications
Computers and Peripherals	www.ti.com/computers
Consumer Electronics	www.ti.com/consumer-apps
Energy and Lighting	www.ti.com/energy
Industrial	www.ti.com/industrial
Medical	www.ti.com/medical
Security	www.ti.com/security
Space, Avionics and Defense	www.ti.com/space-avionics-defense
Video and Imaging	www.ti.com/video

TI E2E Community

e2e.ti.com

Looking for pricing, stock, or lifecycle information?

Click below to explore more details on WIN SOURCE:

 [View LM2696EVAL](#) on WIN SOURCE

 [Texas Instruments](#) Information

Optimize Your Supply Chain with WIN SOURCE Solutions

-  Global Sourcing Solution
-  Obsolete Management
-  Cost Control Management
-  Shortage Management
-  Alternative Solution
-  Excess Inventory Management