



**THE DATASHEET OF
REC16A25-201-C**



MANUAL SETTING TYPE OPTICAL ENCODERS **REC16/RES16**

FEATURES

- High resistant to electrostatic noise by using a plastic shaft
- Compact size of 16 mm square
- With mechanical ON/OFF push switch
- Long life
- RoHS compliant

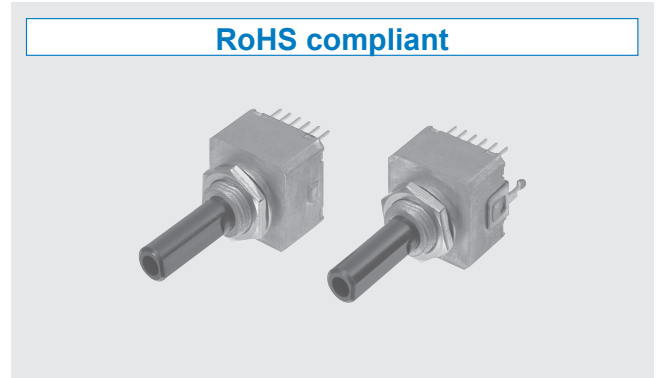

PART NUMBER DESIGNATION

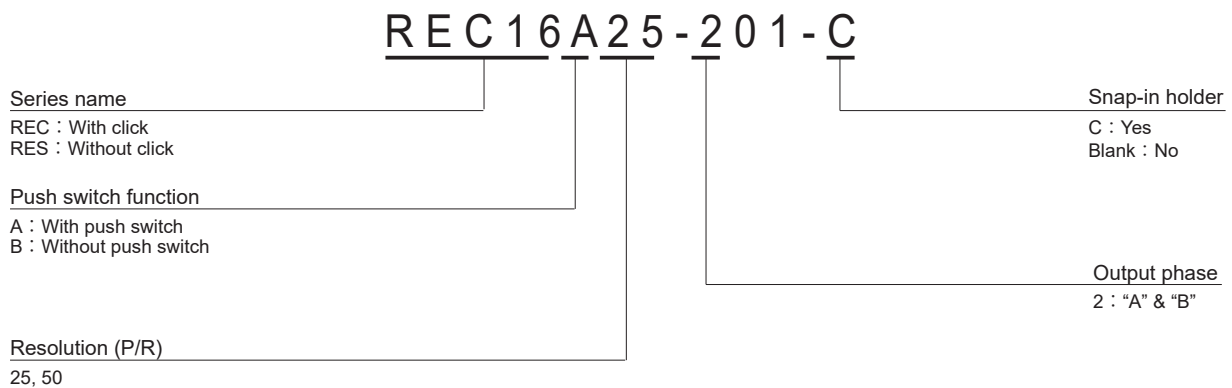

LIST OF PART NUMBERS

Resolution \ Test item	Click	Push switch function	Snap-in holder	Part number
25 (P/R)	With Click	Yes	No	REC16A25-201
			Yes	REC16A25-201-C
	Without Click	No	No	REC16B25-201
			Yes	REC16B25-201-C
			No	RES16B25-201
			Yes	RES16B25-201-C
50 (P/R)	With Click	Yes	No	REC16A50-201
			Yes	REC16A50-201-C
	Without Click	No	No	REC16B50-201
			Yes	REC16B50-201-C
			No	RES16B50-201
			Yes	RES16B50-201-C

REC16/RES16

OPTICAL ENCODERS

STANDARD SPECIFICATIONS

Electrical characteristics

Input voltage	DC5 V \pm 5 %	
Input current	30 mA maximum	
Output wave form	Square wave	
Output phases	A, B	
Resolution(P/R)	25, 50	
Phase difference of outputs A & B	90° \pm 45°	
Maximum frequency response	100 Hz	
Output signal	"1 (High)"	+ 4.5 V minimum
	"0 (Low)"	+ 0.5 V maximum
Light source	LED	
Output Sink Current	3 mA maximum	

Switch characteristics

Maximum contact rating	DC15 V, 20 mA
Contact resistance	200 m Ω maximum (Initial value)

Note) Manual setting only.

Mechanical characteristics

Starting torque	1.18 mN·m \pm 0.78 maximum (12 \pm 8 gf·cm) (RES : Without click)	
Click torque	6.87 mN·m \pm 3.43 maximum (70 \pm 35 gf·cm) (REC : With click)	
Click number	25, 50	
Shaft loading (Pull-push)	19.6 N maximum (2 kgf)	
Switch operation force	7.85 N \pm 2.94 N (800 \pm 300 gf)	
Switch stroke	0.5 mm	
Rotational life (Mechanical)	1 million cycles	
Switching life	1 million cycles	
Shaft loading (When mounting)	Radial	4.90 N maximum (500 gf)
	Axial	2.94 N maximum (300 gf)
Net weight	Approx. 10 g	
Strength of tighten screw	1 N·m {10.2 kgf·cm} maximum	

Environmental characteristics

Operating temp. range	0 ~ 50 °C
Storage temp. range	- 20 ~ 80 °C
Protection grade	IP40

OUTPUT

Click spot for 25P/R

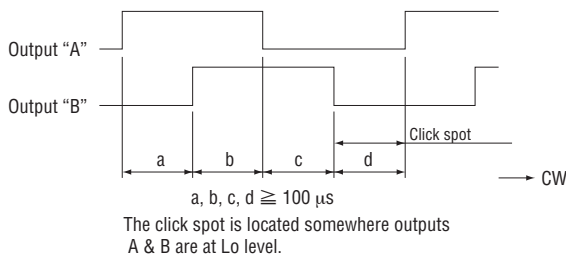

Click spot for 50P/R

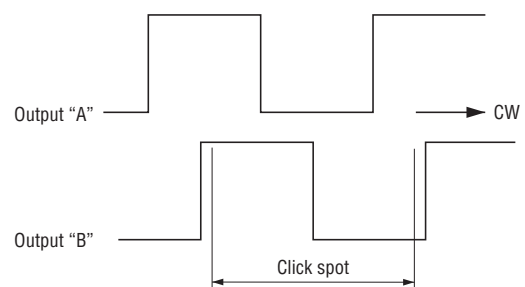

REC16/RES16

OPTICAL ENCODERS

RELIABILITY TEST

The output shall satisfy the criteria below after the following tests.

Test item		Test conditions	
Vibration	Power OFF	Amplitude : 1.52 mm or 98.1 m/s ² (10 G) whichever is smaller. 10 ~ 500 Hz excursion 15 min/cycle, 8 cycles each for X, Z, directions.	
Shock	Power OFF	3 times each in directions (X, Z) at 490 m/s ² (50 G), 11 ms.	
High temperature exposure	Power OFF	80 °C 96 h	To be measured after leaving samples for 1 h at normal temperature and humidity after the test.
	Power ON	50 °C 96 h	
Low temperature exposure	Power OFF	- 20 °C 96 h	
	Power ON	0 °C 96 h	
Humidity	Power OFF	To be measured after wiping out moisture and leaving samples for 1 h at normal temperature and humidity after the test.	
Thermal shock	Power OFF	To be done 10 cycles with the following condition (To be measured after leaving samples for 1 h at normal temperature and humidity after the test.) 80 °C 0.5 h、 - 20 °C 0.5 h	

OUTLINE DIMENSIONS

Unless otherwise specified, tolerance: ± 0.4(Unit: mm)

Without snap-in holder

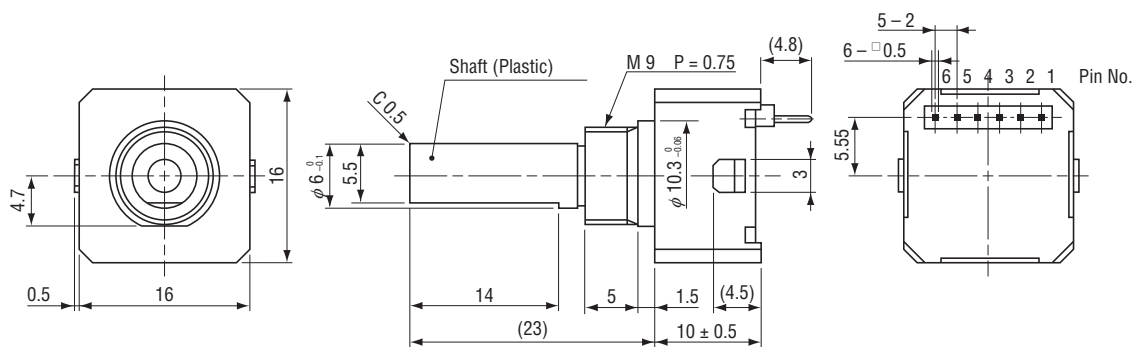

※ Connector : A4B-6PA-2DSA
Made by Hirose Electric Co., Ltd.

REC16/RES16 OPTICAL ENCODERS

OUTLINE DIMENSIONS

With snap-in holder

Unless otherwise specified, tolerance: ± 0.4 (Unit: mm)

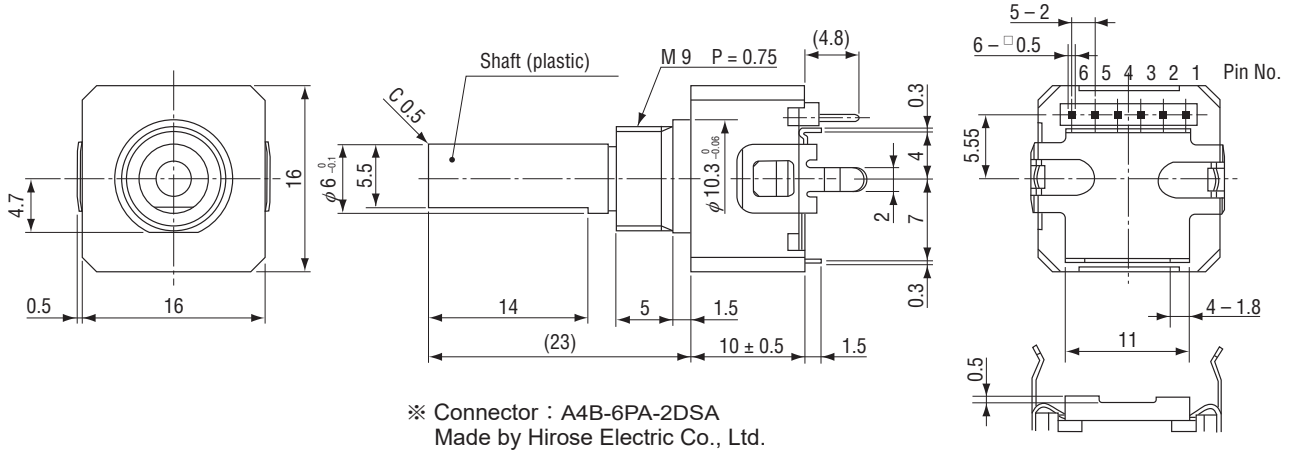

<Accessories>

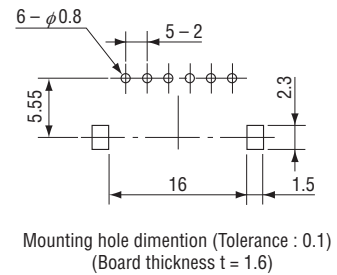
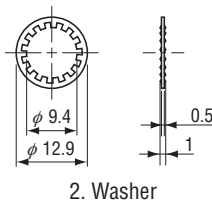
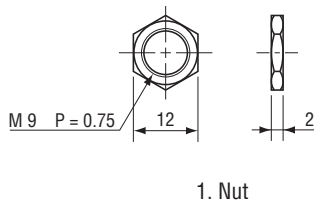

PIN ASSIGNMENT

Pin No.	With switch	Without switch
1	Power 0 (V)	Power 0 (V)
2	Output "B"	Output "B"
3	For switch	N C
4	For switch	N C
5	Power ⊕	Power ⊕
6	Output "A"	Output "A"

OUTPUT CIRCUIT

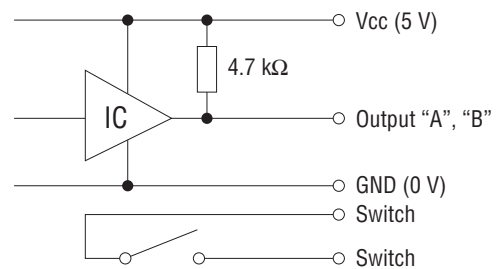

● KNOB FOR SETTING ENCODERS

The knobs are sold separately as an optional item. (Ref. P. 314)

Looking for pricing, stock, or lifecycle information?

Click below to explore more details on WIN SOURCE:

- ⊖ [View REC16A25-201-C on WIN SOURCE](#)
- ⊖ [Nidec Copal Electronics Information](#)

Optimize Your Supply Chain with WIN SOURCE Solutions

- ✓ Global Sourcing Solution
- ✓ Obsolete Management
- ✓ Cost Control Management
- ✓ Shortage Management
- ✓ Alternative Solution
- ✓ Excess Inventory Management