



**THE DATASHEET OF
TLE493DP2B6A2HTSA1**



TLE493D-P2B6

High Accuracy Low Power 3D Hall Sensor with I²C Interface

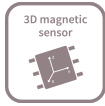

ISO26262
ready

Features

- 3D (X, Y, Z) magnetic flux density sensing of ± 160 mT
- Programmable flux resolution down to $65 \mu\text{T}$ (typ.)
- X-Y angular measurement mode
- Diagnostic measurements to check digital parts, analog parts and Hall probe of the sensor
- Wake Up function and Power down mode with 7 nA (typ.) power consumption
- 12-bit data resolution for each measurement direction plus 10-bit temperature sensor
- Variable update frequencies and power modes (configurable during operation)
- Temperature range $T_j = -40^\circ\text{C} \dots 125^\circ\text{C}$, supply voltage range = $2.8 \text{ V} \dots 3.5 \text{ V}$
- Triggering by external μC possible via I²C protocol
- Interrupt signal to indicate a valid measurement to the microcontroller



PG-TSOP6-6-8

Potential applications

The TLE493D-P2B6 is designed for a wide range of magnetic sensing, including the following:

- Gear stick position
- Control elements in the top column module and multi function steering wheel
- Multi function knobs
- Pedal/valve position sensing

Benefits

- Component reduction due to 3D magnetic measurement principle
- Wide application range addressable due to high flexibility
- Platform adaptability due to device configurability
- Supporting functional safety by means of integrated diagnostics
- Very low system power consumption due to Wake-Up mode resulting in extended battery runtime
- Disturbance of smaller stray fields are neglectable compared to the high magnetic flux measurement range

Product validation

Qualified for Automotive Applications. Product validation according to AEC-Q100.

Ordering information

Ordering information

Product type	Marking ¹⁾	Ordering code	Package	Default address write/read
TLE493D-P2B6 A0	P0	SP005557415	PG-TSOP6-6-8	6A _H / 6B _H
TLE493D-P2B6 A1	P1	SP005557413	PG-TSOP6-6-8	44 _H / 45 _H
TLE493D-P2B6 A2	P2	SP005557411	PG-TSOP6-6-8	F0 _H / F1 _H
TLE493D-P2B6 A3	P3	SP005557408	PG-TSOP6-6-8	88 _H / 89 _H

¹ Engineering samples are marked with “SA”

Table of contents

	Features	1
	Potential applications	1
	Benefits	1
	Product validation	1
	Ordering information	2
	Table of contents	3
1	Functional description	4
1.1	General	4
1.1.1	Power mode control	4
1.1.2	Sensing	5
1.1.3	Wake-Up	5
1.2	Pin configuration (top view)	5
1.3	Definition of magnetic field	6
1.4	Sensitive area	6
1.5	Application circuit	7
2	Specification	8
2.1	Absolute maximum ratings	8
2.2	Operating range	9
2.3	Electrical characteristics	10
2.4	Magnetic characteristics	11
2.5	Temperature measurement	13
2.6	Overview of modes	14
2.7	Interface and timing description	15
3	Package information	17
3.1	Package parameters	17
3.2	Package outlines	18
	Revision history	20
	Disclaimer	21

Functional description

1 Functional description

This three dimensional Hall effect sensor can be configured by the microcontroller. The measurement data is provided in digital format to the microcontroller. The microcontroller is the master and the sensor is the slave. It also provides test functions and the capability to Wake-Up a sleeping system.

1.1 General

Description of the block diagram and its functions.

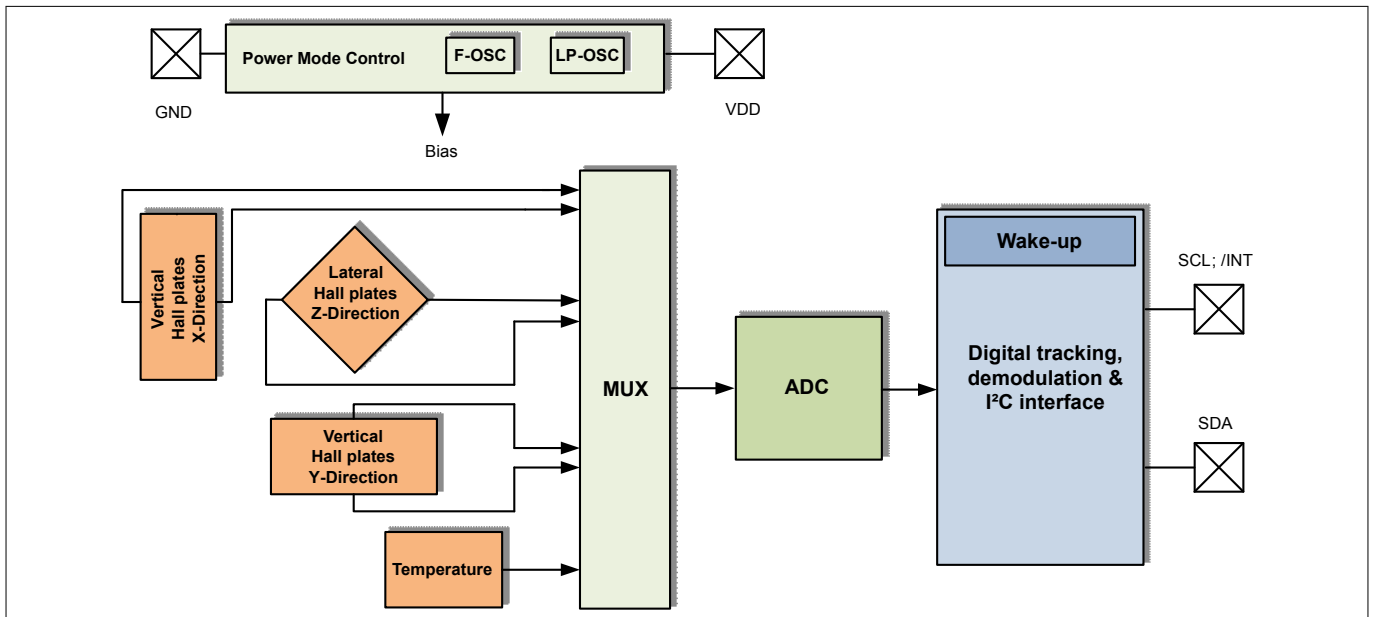

Figure 1 Block diagram

The IC consists of three main functional units containing the following building blocks:

- The power mode control system, containing a low-power oscillator, basic biasing, accurate restart, undervoltage detection and a fast oscillator.
- The sensing unit, which contains the HALL biasing, HALL probes with multiplexers and successive tracking ADC, as well as a temperature sensor is implemented.
- The I²C interface, containing the register files and I/O pads

1.1.1 Power mode control

The power mode control provides the power distribution in the IC, a power-on reset function and a specialized low-power oscillator as the clock source. It also manages the start-up behavior.

- On start-up, this unit:
 - activates the biasing, provides an accurate reset detector and fast oscillator
 - sensor enters low power mode and can be configured via I²C interface
- After re-configuration, a measurement cycle is performed, which consists of the following steps:
 - activating internal biasing, checking for the restart condition and providing the fast oscillator
 - HALL biasing
 - measuring the three HALL probe channels sequentially (including the temperature). This is enabled by default
 - reentering configured mode

Functional description

In any case functions are only executed if the supply voltage is high enough, otherwise the restart circuit will halt the state machine until the required level is reached and restart afterwards. The functions are also restarted if a restart event occurs in between (see parameter **ADC restart level**).

1.1.2 Sensing

Measures the magnetic field in X, Y and Z direction. Each X-, Y- and Z-Hall probe is connected sequentially to a multiplexer, which is then connected to an analog to digital converter (ADC). Optional, the temperature (default = activated) can be determined as well after the three Hall channels.

1.1.3 Wake-Up

For each of the three magnetic channels (X/Y/Z), the Wake-Up function has an upper and lower comparison threshold. Each component of the applied field is compared to the lower and upper threshold. If one of the results is above or below these thresholds, an interrupt pulse /INT is generated. This is called a Wake-Up function. The sensor signals a certain field strength change to the microcontroller. As long as all components of the field stay within the envelope, no interrupt signal will be provided. Note however that the /INT can also be inhibited during I²C activities, by activated collision avoidance. A Wake-Up interrupt /INT is the logical OR among all Wake-Up interrupt envelopes of the three channels.

1.2 Pin configuration (top view)

Figure 2 shows the pinout of the TLE493D-P2B6.

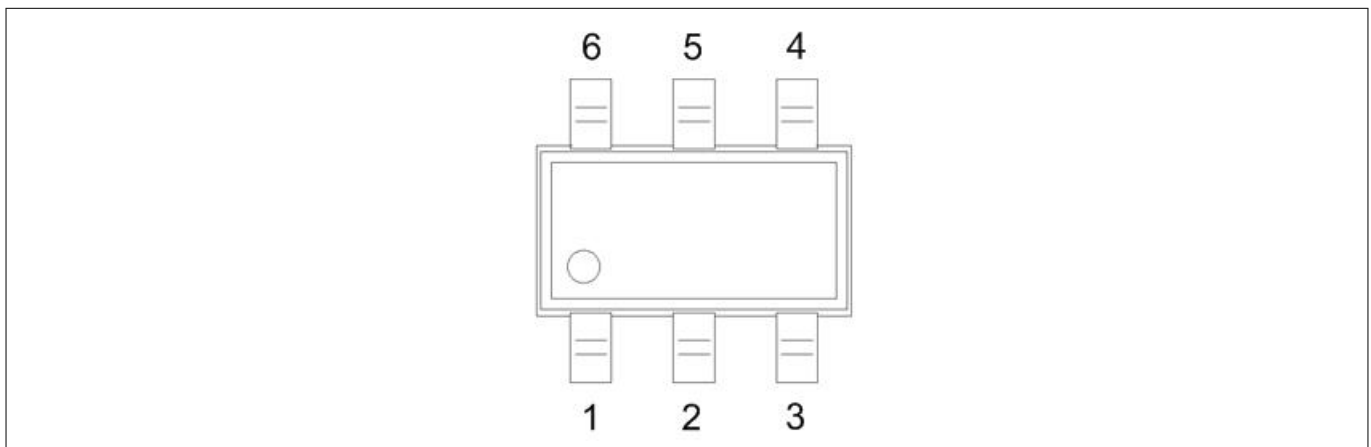

Figure 2 TLE493D-P2B6 pinout

Table 1 TSOP6 pin description and configuration (see Figure 2)

Pin no.	Name	Description
1	SCL /INT	Interface serial clock pin (input) Interrupt pin, signals a finished measurement cycle, open-drain
2	GND	Connect to GND
3	GND	Ground pin
4	VDD	Supply pin
5	GND	Connect to GND
6	SDA	Interface serial data pin (input/output), open-drain

Functional description

1.3 Definition of magnetic field

A positive field is considered as south-pole facing the corresponding Hall element.

Figure 3 shows the definition of the magnetic directions X, Y, Z of the TLE493D-P2B6.

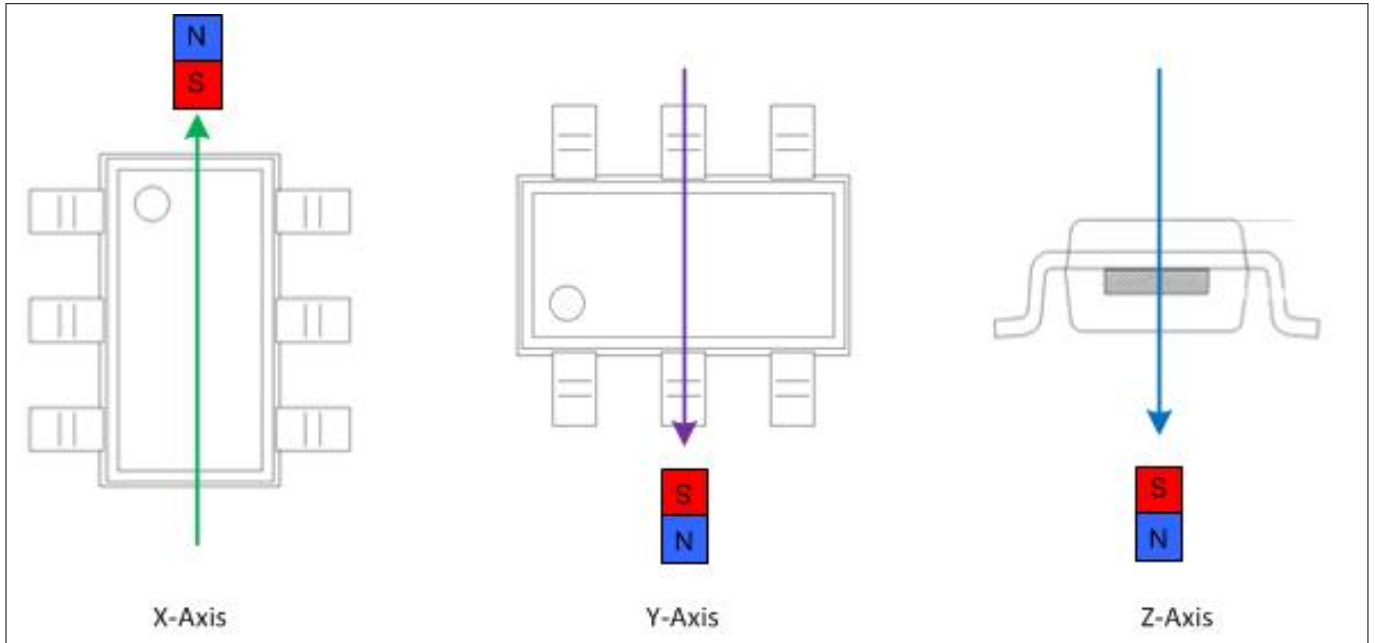

Figure 3 Definition of magnetic field direction

1.4 Sensitive area

The magnetic sensitive area for the Hall measurement is shown in *Figure 4*.

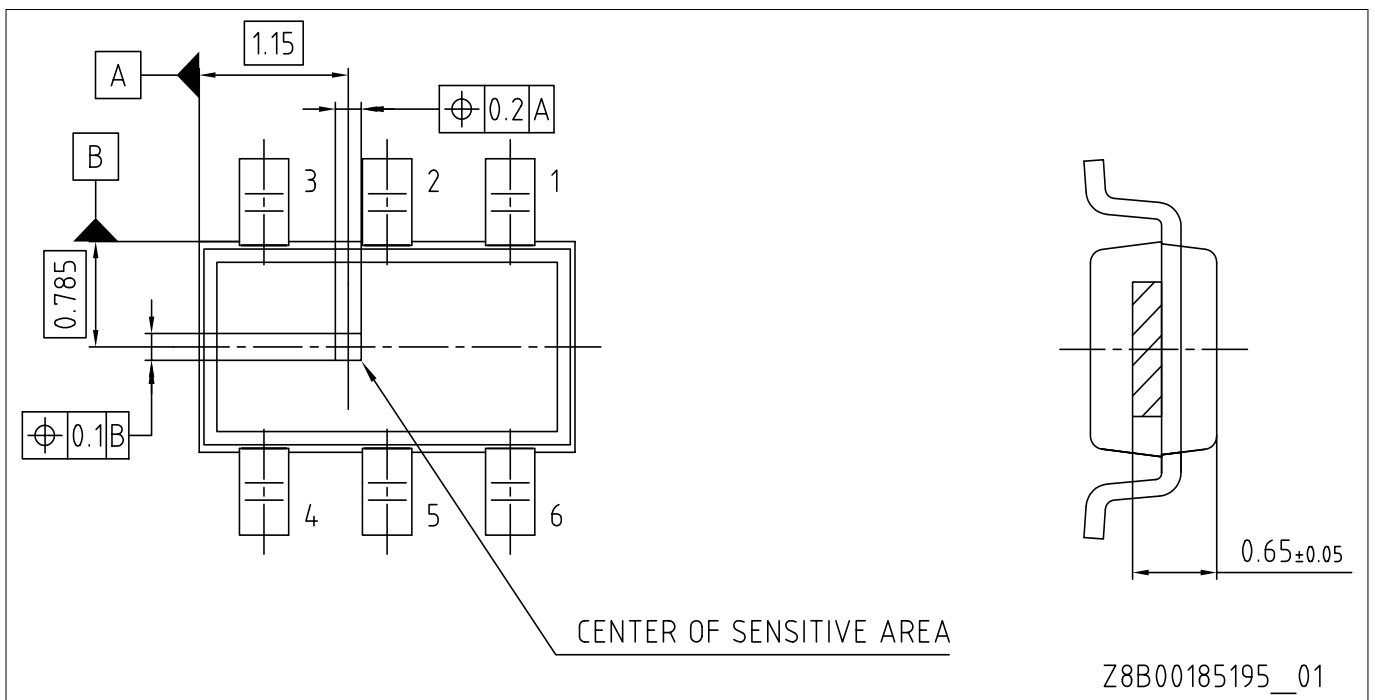

Figure 4 Center of sensitive area (dimensions in mm)

Functional description

1.5 Application circuit

The use of an interrupt line is optional, but highly recommended to ensure proper and efficient readout of the sensor data.

The pull-up resistor values of the I²C bus have to be calculated in such a way as to fulfill the rise and fall time specification of the interface for the given worst case parasitic (capacitive) load of the actual application setup.

Please note: Too small resistive R1/2 values have to be prevented to avoid unnecessary power consumption during interface transmissions, especially for low-power applications.

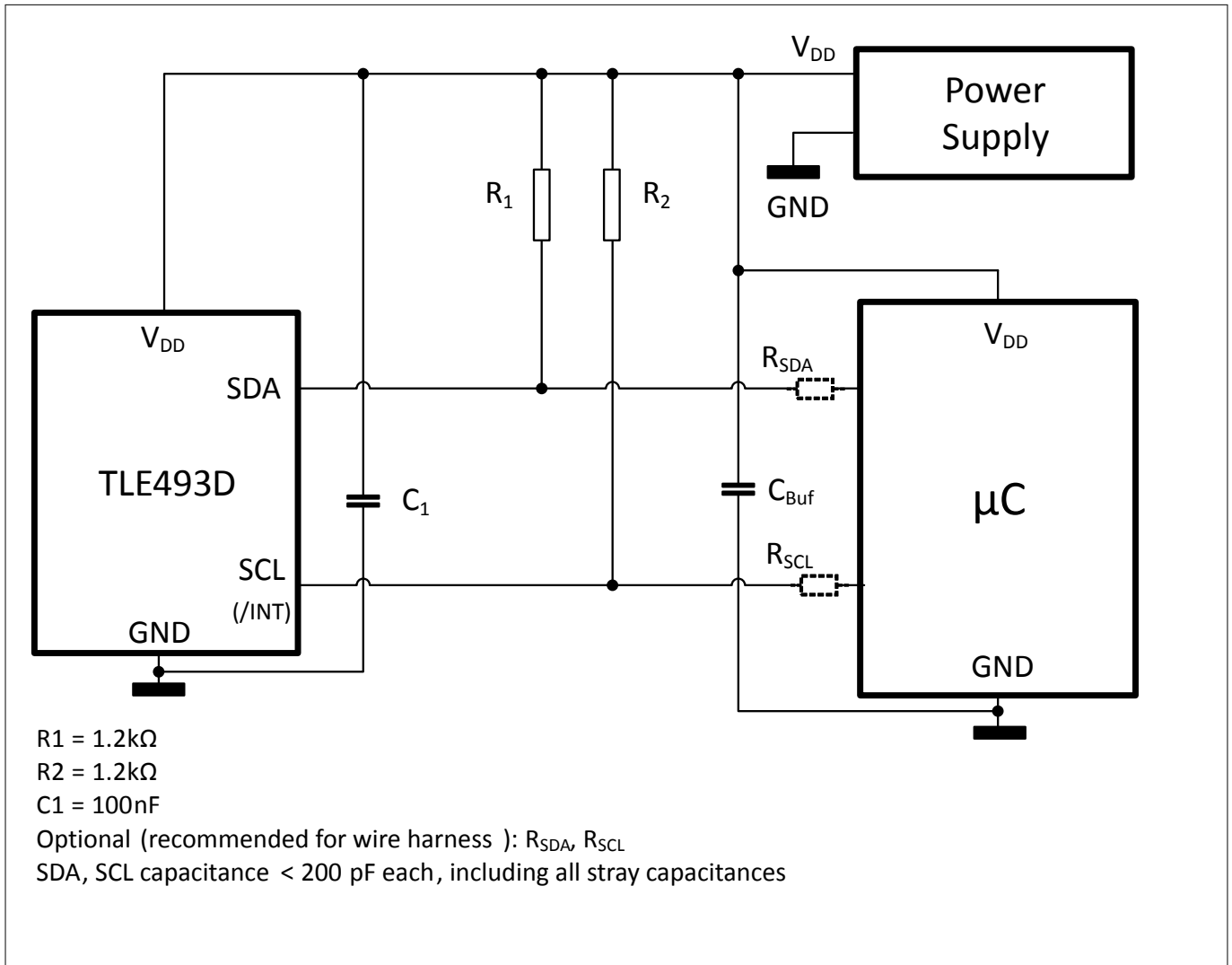

Figure 5 Application circuit with external power supply and µC

For additional EMC precaution in harsh environments, C_1 may be implemented by two 100 nF capacitors in parallel, which should be already given by C_{Buf} near the µC and/or power supply.

Specification

2 Specification

This sensor is intended to be used in an automotive environment. This chapter describes the environmental conditions required by the device (magnetic, thermal and electrical).

2.1 Absolute maximum ratings

Stresses above those listed under “Absolute maximum ratings” may cause permanent damage to the device. This is a stress rating only and functional operation of the device at these or any other conditions above those indicated in the operational sections of this specification is not implied. Furthermore, only single error cases are assumed. More than one stress/error case may also damage the device.

Exposure to absolute maximum rating conditions for extended periods may affect device reliability. During absolute maximum rating overload conditions the voltage on V_{DD} pin with respect to ground (GND) must not exceed the values defined by the absolute maximum ratings.

Table 2 Absolute maximum ratings

Parameter	Symbol	Values			Unit	Note or test condition
		Min.	Typ.	Max.		
Junction temperature	T_j	-40	–	125	°C	
Voltage on V_{DD}	V_{DD}	-0.3	–	3.5	V	
Magnetic field	B_{max}	–	–	±1	T	
Voltage range on any pin to GND	V_{max}	-0.1	–	3.5	V	open-drain outputs are not current limited.

Table 3 ESD protection²⁾

Ambient temperature $T_A = 25^\circ\text{C}$

Parameter	Symbol	Values			Unit	Note or test condition
		Min.	Typ.	Max.		
ESD voltage (HBM) ³⁾	V_{ESD}	–	–	±2.0	kV	$R = 1.5\text{ k}\Omega$, $C = 100\text{ pF}$
ESD voltage (CDM) ⁴⁾		–	–	±0.75	kV	for corner pins
		–	–	±0.5	kV	all pins

²⁾ Characterization of ESD is carried out on a sample basis, not subject to production test.

³⁾ Human body model (HBM) tests according to ANSI/ESDA/JEDEC JS-001.

⁴⁾ Charged device model (CDM), ESD susceptibility according to JEDEC JESD22-C101.

Specification

2.2 Operating range

To achieve ultra low power consumption, the chip does not use a conventional, power-consuming restart procedure. The focus of the restart procedure implemented is to ensure a proper supply for the ADC operation only. So it inhibits the ADC until the sensor supply is high enough.

Table 4 Operating range

Parameter	Symbol	Values			Unit	Note or test condition
		Min.	Typ.	Max.		
Operating temperature	T_j	-40	-	125	°C	$T_j = T_a + 3$ K in fast mode
Supply voltage	V_{DD}	2.8	3.3	3.5	V	Supply voltage must be above restart level
ADC restart level	V_{res}	2.2	2.5	2.8	V	Min. ADC operating level
ADC restart hysteresis	$V_{res-hys}$	-	50	-	mV	
Register stable level	V_{reg}	-	-	2.5	V	Register values are stable above this voltage level

The sensor relies on a proper supply ramp defined with t_{PUP} , V_{OUS} and I_{DD-PUP} , see [Figure 6](#). The I²C reset feature of the sensor shall be used by the μ C after power up. If supply monitoring is used in the system (e.g. brown-out detector etc.), it is also recommended to use the I²C reset of the sensor following events detected by this monitor.

In any case, an external supply switch (either provided by a system-basis-chip solution which includes a supply-enable feature, a Bias-resistor-transistor device, a capable μ C GPIO pin, etc.) shall allow a power-cycle of the sensor as backup for high availability applications to cope with any form of V_{DD} ramps (including potential EMC influences), see [Figure 6](#).

At power up, SDA and SCL shall be pulled to V_{DD} using R1 and R2 of [Figure 5](#) and not be driven to low by any device or μ C on SDA and SCL.

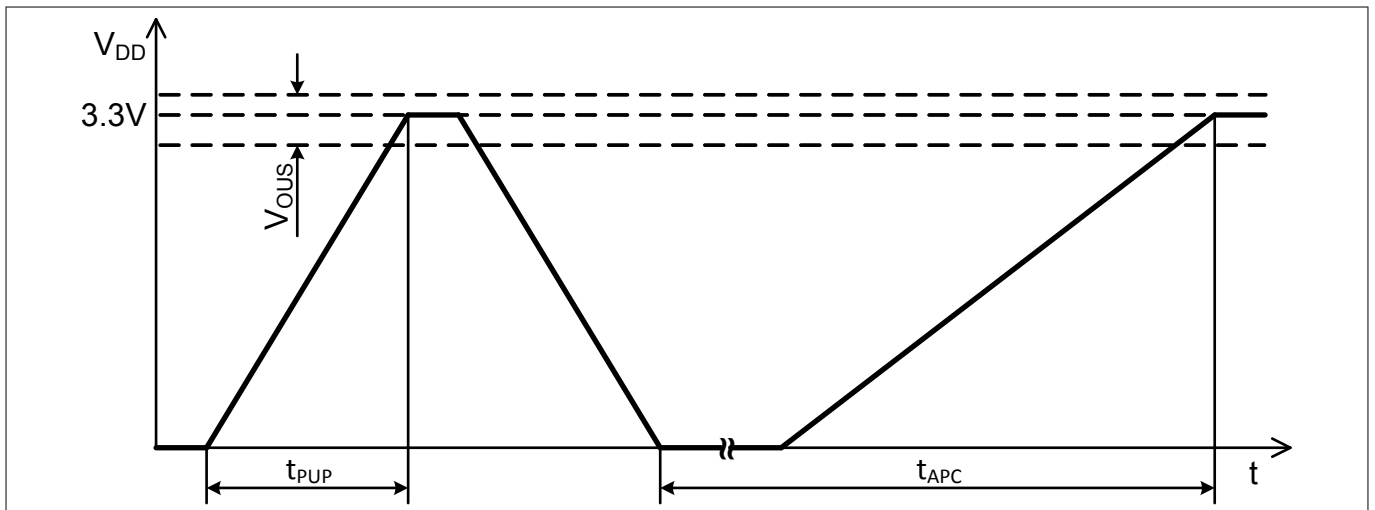

Figure 6 V_{DD} power up and power cycle for high availability

Specification

Table 5 **V_{DD} power up and power cycle**

Parameter	Symbol	Values			Unit	Note or test condition
		Min.	Typ.	Max.		
Power up ramp time	t_{PUP}	–	–	10	μs	
Availability power cycle ⁵⁾	t_{APC}	–	150	400	μs	
Power up over- undershoot	V_{OUS}	3	3.3	3.5	V	Envelope which must not be exceeded at the end of a power up.
Power up current consumption	I_{DD-PUP}	–	–	10	mA	Current consumption during t_{PUP}

2.3 Electrical characteristics

This sensor provides different operating modes and a digital communication interface. The corresponding electrical parameters are listed in [Table 6](#). Regarding current consumption more information are available in [Chapter 2.6](#).

Table 6 **Electrical setup**

Values for $V_{DD} = 3.3\text{ V} \pm 5\%$, $T_j = -40^\circ\text{C}$ to 125°C (unless otherwise specified)

Parameter	Symbol	Values			Unit	Note or test condition
		Min.	Typ.	Max.		
Supply current ⁶⁾	I_{DD_pd}	–	7	130	nA	$T_j = 25^\circ\text{C}$; power down mode
	I_{DD_fm}	1	3.4	5	mA	Fast mode
Input voltage low threshold ⁷⁾	V_{IL}	–	–	30	% V_{DD}	All input pads
Input voltage high threshold ⁷⁾	V_{IH}	70	–	–	% V_{DD}	All input pads
Input voltage hysteresis ⁷⁾	V_{IHYS}	5	–	–	% V_{DD}	All input pads
Output voltage low level @ 3 mA load	V_{OL}	–	–	0.4	V	All output pads, static load

⁵ Not subject to production test - verified by design.

⁶ Currents at pull up resistors ([Figure 5](#)) needs to be considered for power supply dimensioning.

⁷ Based on I²C standard 1995 for V_{DD} related input levels

Specification

2.4 Magnetic characteristics

The magnetic parameters are specified for an end of line production scenario and for an application life time scenario. The magnetic measurement values are provided in the two's complement with 12 bit or 8 bit resolution in the registers with the symbols B_x, B_y and B_z. Two examples, how to calculate the magnetic flux density are shown in [Table 10](#) and [Table 11](#).

Table 7 Initial magnetic characteristics⁸⁾

Values for V_{DD} = 3.3 V, T_j = 25°C (unless otherwise specified)

Parameter	Symbol	Values			Unit	Note or test condition
		Min.	Typ.	Max.		
Magnetic linear range ⁹⁾ (full range)	B _{xyz_LIN}	-160	-	160	mT	-40°C < T _j < 125°C
Magnetic linear range ⁹⁾ (short range)	B _{xyz_LINSR}	-100	-	100	mT	
Sensitivity X, Y, Z (full range)	S _x , S _y , S _z	6	7.7	10	LSB ₁₂ / mT	
Sensitivity X, Y, Z (short range)	S _{xSR} , S _{ySR} , S _{zSR}	12	15.4	20		
Z-Offset (full range and short range)	B _{0z}	-1.8	±0.2	1.8	mT	@ 0 mT
XY-Offset (full range and short range)	B _{0xy}	-0.75	±0.2	0.75	mT	@ 0 mT
X to Y magnetic matching ¹⁰⁾	M _{XY}	-5	±1	5	%	
X/Y to Z magnetic matching ¹⁰⁾	M _{X/YZ}	-19	-4	11	%	
Magnetic initial noise (rms) (full range and short range)	B _{ineff}	-	0.1	0.4	mT	rms = 1 sigma
Magnetic hysteresis ⁹⁾ (full range and short range)	B _{HYS}	-	1	-	LSB ₁₂	due to quantization effects

$$M_{XY} = 100 \cdot 2 \cdot \frac{S_x - S_y}{S_x + S_y} [\%]$$

Equation 1 Parameter “X to Y magnetic matching”

$$M_{X/YZ} = 100 \cdot 2 \cdot \frac{S_x + S_y - 2 \cdot S_z}{S_x + S_y + 2 \cdot S_z} [\%]$$

Equation 2 Parameter “X/Y to Z magnetic matching”

⁸⁾ Magnetic test on wafer level. It is assumed that initial variations are stored and compensated in the external μC during module test and calibration.

⁹⁾ Not subject to production test - verified by design/characterization.

¹⁰⁾ See the magnetic matching definition in [Equation 1](#) and [Equation 2](#).

Specification

Table 8 **Sensor drifts¹¹⁾ valid for both full range and short range (unless indicated)**

Values for $V_{DD} = 3.3 \text{ V} \pm 5\%$, $T_j = -40^\circ\text{C}$ to 125°C , static magnetic field within full magnetic linear range (unless otherwise specified)

Parameter	Symbol	Values			Unit	Note or test condition
		Min.	Typ.	Max.		
Sensitivity drift X, Y, Z	$S_{X_D}, S_{Y_D}, S_{Z_D}$	-15	± 5	15	%	TC_0
Offset drift X, Y	B_{O_DXY}	-0.45	-	0.45	mT	@ 0 mT, TC_0
Offset drift Z	B_{O_DZ}	-1.6	-	1.6	mT	@ 0 mT, TC_0
Offset drift Z	B_{O_DZ}	-0.45	-	0.45	mT	@ 0 mT, TC_0 , Z Hall spin test
X to Y magnetic matching drift ¹²⁾	M_{XY_D}	-1.9	± 0.5	1.9	%	TC_0
X/Y to Z magnetic matching drift ¹²⁾	M_{X/YZ_D}	-12	± 5	12	%	TC_0

Table 9 **Temperature compensation, non-linearity and noise¹³⁾**

Values for $V_{DD} = 3.3 \text{ V} \pm 5\%$, $T_j = -40^\circ\text{C}$ to 125°C (unless otherwise specified)

Parameter	Symbol	Values			Unit	Note or test condition
		Min.	Typ.	Max.		
Temperature compensation ¹⁴⁾ (full range and short range)	TC_0	-	± 0	-	ppm/K	Bx, By and Bz (default)
	TC_1	-	-750	-		Bx, By and Bz (option 1)
	TC_2	-	-1500	-		Bx, By and Bz (option 2)
	TC_3	-	+350	-		Bx, By and Bz (option 3)
Differential non linearity (full range)	DNL	-	± 2	-	LSB ₁₂	Bx, By and Bz
Differential non linearity (short range)	DNL_{SR}	-	± 4	-		
Integral non linearity (full range)	INL	-	± 2	-	LSB ₁₂	Bx, By and Bz
Integral non linearity (short range)	INL_{SR}	-	± 4	-		
Magnetic noise (rms)	B_{Neff}	-	-	1	mT	rms = 1 sigma
Z-magnetic noise (rms)	B_{NeffZ}	-	-	0.5	mT	rms = 1 sigma, -40°C < T_j < 85°C
XY-magnetic noise (rms)	B_{NeffXY}	-	-	0.25	mT	

¹¹⁾ Not subject to production test, verified by design/characterization. Drifts are changes from the initial characteristics **Table 7** due to external influences.

¹²⁾ See the magnetic matching definition in **Equation 1** and **Equation 2**.

¹³⁾ Not subject to production test, verified by design/characterization.

¹⁴⁾ TC_x must be set before magnetic flux trimming and measurements with the same value.

Specification

Conversion register value to magnetic field value:

Table 10 **Magnetic conversion table for 12 bit**

	MSB	Bit10	Bit9	Bit8	Bit7	Bit6	Bit5	Bit4	Bit3	Bit2	Bit1	LSB
[Dec]	-2048	1024	512	256	128	64	32	16	8	4	2	1
[Bin] e.g.	1	1	1	1	0	0	0	0	1	1	1	1

The conversion is realized by the two's complement. Please use following table for transformation:

Example for 12-bit read out: 1111 0000 1111_B: -2048 + 1024 + 512 + 256 + 0 + 0 + 0 + 0 + 8 + 4 + 2 + 1 = -241 LSB₁₂

Calculation of magnetic flux density: -241 LSB₁₂ × 0.13 mT/LSB₁₂ = -31.3 mT

Table 11 **Magnetic conversion table for 8 bit**

	MSB	Bit10	Bit9	Bit8	Bit7	Bit6	Bit5	LSB
[Dec]	-128	64	32	16	8	4	2	1
[Bin] e.g.	0	0	1	1	1	1	0	1

Example for 8-bit read out: 0011 1101_B: 0 + 0 + 32 + 16 + 8 + 4 + 0 + 1 = 61 LSB₈

Calculation of magnetic flux density (full range): 61 LSB₈ × 16 / 7.7 LSB₈/mT = 127 mT

2.5 Temperature measurement

By default, the temperature measurement is activated. The temperature measurement can be disabled if it is not needed and to increase the speed of repetition of the magnetic values.

Table 12 **Temperature measurement characteristics¹⁵⁾**

Parameter	Symbol	Values			Unit	Note or test condition
		Min.	Typ.	Max.		
Digital value @ 25°C	T ₂₅	1000	1180	1360	LSB ₁₂	
Temperature resolution, 12 bit	T _{Res12}	0.21	0.24	0.27	K/LSB ₁₂	referring to T _j
Temperature resolution, 8 bit	T _{Res8}	–	3.84	–	K/LSB ₈	referring to T _j

Table 13 **Temperature conversion table for 12 bit**

The bits MSB to Bit2 are read out from the temperature value registers. Bit1 and LSB are added to get a 12-bit value for calculation.

	MSB	Bit10	Bit9	Bit8	Bit7	Bit6	Bit5	Bit4	Bit3	Bit2
[Dec]	-2048	1024	512	256	128	64	32	16	8	4
[Bin] e.g.	0	1	0	1	0	0	1	0	1	1

Example for 12-bit calculation: 0110 1010 11_B: 0 + 1024 + 0 + 256 + 0 + 0 + 32 + 0 + 8 + 4 = 1324 LSB₁₂

Calculation to temperature: (1324 LSB₁₂ - 1180 LSB₁₂) × 0.24 K/LSB₁₂ + 25°C ≈ 60°C

¹⁵⁾ The temperature measurement is not trimmed on the sensor. An external μC can measure the sensor during module production and implement external trimming to gain higher accuracies. Temperature values are based on 12 bit resolution. Please note: only bit 11 ... 2 are listed in the bitmap registers.

Specification

2.6 Overview of modes

For a good adaptation on application requirements this sensor is equipped with different modes. An overview is listed in [Table 14](#).

Table 14 Overview of modes¹⁶⁾

Mode	Measurements	Typ. f _{Update} ¹⁷⁾	Description
Power down	No measurements	–	Lowest possible supply current I _{DD}
Low power mode (full range and short range)	Bx, By, Bz, T	0.05 Hz - 770 Hz (8 steps)	Cyclic measurements and ADC-conversions with different update rates
	Bx, By, Bz		
	Bx, By		
Fast mode (full range)	Bx, By, Bz, T	5.8 kHz	Measurements and ADC conversions are running continuously. An I ² C clock speed up to 1 MHz and use of the interrupt /INT is required.
	Bx, By, Bz	7.8 kHz	
	Bx, By	11.6 kHz	
Fast mode (short range)	Bx, By, Bz, T	4.5 kHz	
	Bx, By, Bz	5.6 kHz	
	Bx, By	8.5 kHz	
Master controlled mode (full range and short range)	Bx, By, Bz, T	Up to fast mode values	Measurements triggered by the microcontroller via I ² C
	Bx, By, Bz		
	Bx, By		

Typical I_{DD} current consumption estimation formula (e.g. full range and all channels):

$$I_{DD} \approx I_{DD_fm} \cdot f_{Update} \cdot (t_{Bx} + t_{By} + t_{Bz} + t_{Temp})$$

Equation 3 *I_{DD} estimation formula*

¹⁶ Not subject to production test - verified by design/characterization.

¹⁷ This is the frequency at which specified measurements are updated.

Specification

2.7 Interface and timing description

This chapter refers to how to set the boundary conditions in order to establish a proper interface communication.

Table 15 Interface and timing¹⁸⁾

Parameter	Symbol	Values			Unit	Note or test condition
		Min.	Typ.	Max.		
Bx, By and Bz conversion time (full range)	t_{Bx} , t_{By} , t_{Bz}	32	43	54	μs	
Bx, By and Bz conversion time (short range)	t_{Bx_SR} , t_{By_SR} , t_{Bz_SR}	44	59	74	μs	
Temp conversion time (all ranges)	t_{Temp}	32	43	54	μs	
/INT pulse width	t_{INT}	1.8	2.5	3.2	μs	
/INT delay	t_{INT_d}	1.8	2.5	3.2	μs	

I²C timings

Allowed I ² C bit clock frequency ¹⁹⁾	f_{I2C_clk}	–	400	1000	kHz	
Low period of SCL clock	t_L	0.5	–	–	μs	1.3 μs for 400-kHz mode
High period of SCL clock	t_H	0.4	–	–	μs	0.6 μs for 400-kHz mode
SDA fall to SCL fall hold time (hold time start condition to clock)	t_{STA}	0.4	–	–	μs	0.6 μs for 400-kHz mode
SCL rise to SDA rise setup time (setup time clock to stop condition)	t_{STOP}	0.4	–	–	μs	0.6 μs for 400-kHz mode
SDA rise to SDA fall hold time (wait time from stop to start cond.)	t_{WAIT}	0.4	–	–	μs	0.6 μs for 400-kHz mode
SDA setup before SCL rising	t_{SU}	0.1	–	–	μs	
SDA hold after SCL falling	t_{HOLD}	0	–	–	μs	
Fall time SDA/SCL signal ²⁰⁾	t_{FALL}	–	0.25	0.3	μs	
Rise time SDA/SCL signal ²⁰⁾	t_{RISE}	–	0.5	–	μs	R = 1.2 k Ω

The fast mode, shown in **Figure 7**, requires a very strict I²C behavior synchronized with the sensor conversions and high bit rates. In this mode, a fresh measurement cycle is started immediately after the previous cycle was completed.

Other modes are available for more relaxed timing and also for a synchronous microcontroller operation of sensor conversions. In these modes, a fresh measurement cycle is only started if it is triggered by an internal or external trigger source.

¹⁸ Not subject to production test - verified by design/characterization

¹⁹ Dependent on R-C-combination on SDA and SCL. Ensure reduced capacitive load for speeds above 400 kHz.

²⁰ Dependent on used R-C-combination.

Specification

In the default measurement configuration (Bx, By, Bz and T), shown in **Figure 7**, the measurement cycle ends after the temperature measurement.

In 3-channel measurement configuration (Bx, By and Bz), the temperature channel is not converted and updated. Thus, the measurement cycle ends after the Bz measurement.

In X/Y angular measurement configuration (Bx and By), the Bz and temperature channel are not converted and updated. Thus, the measurement cycle ends after the By measurement.

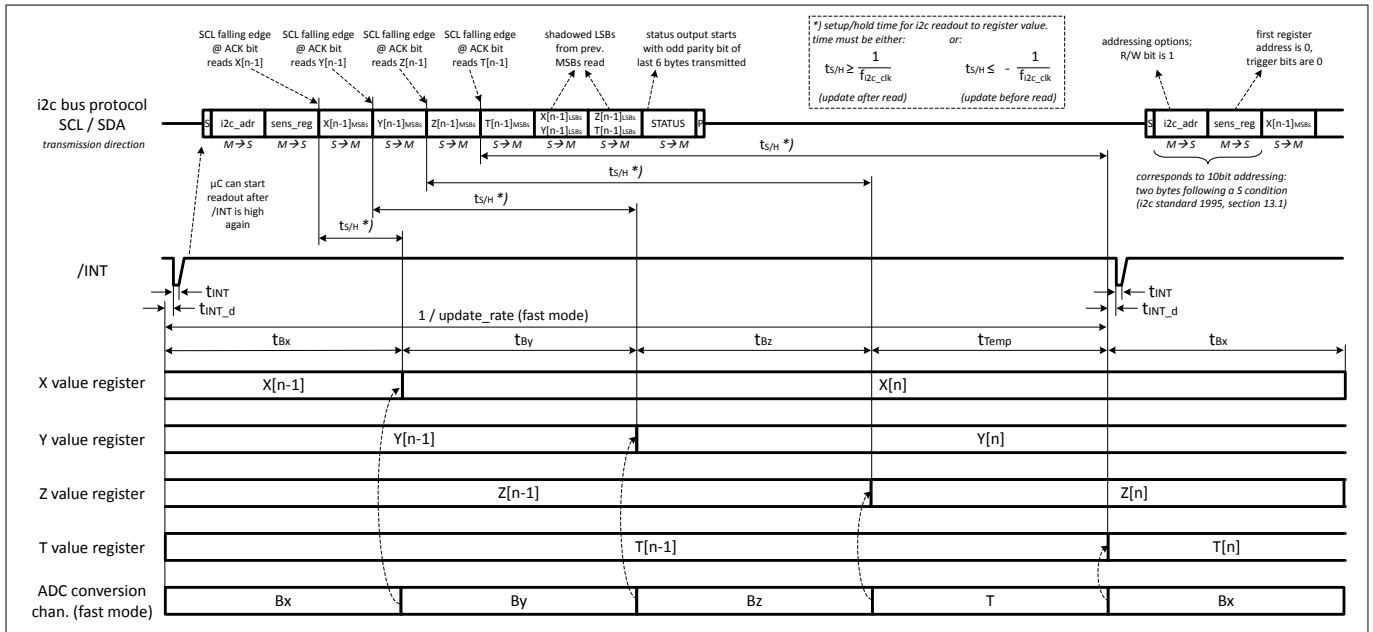

Figure 7 I²C readout frame, ADC conversion and related timing

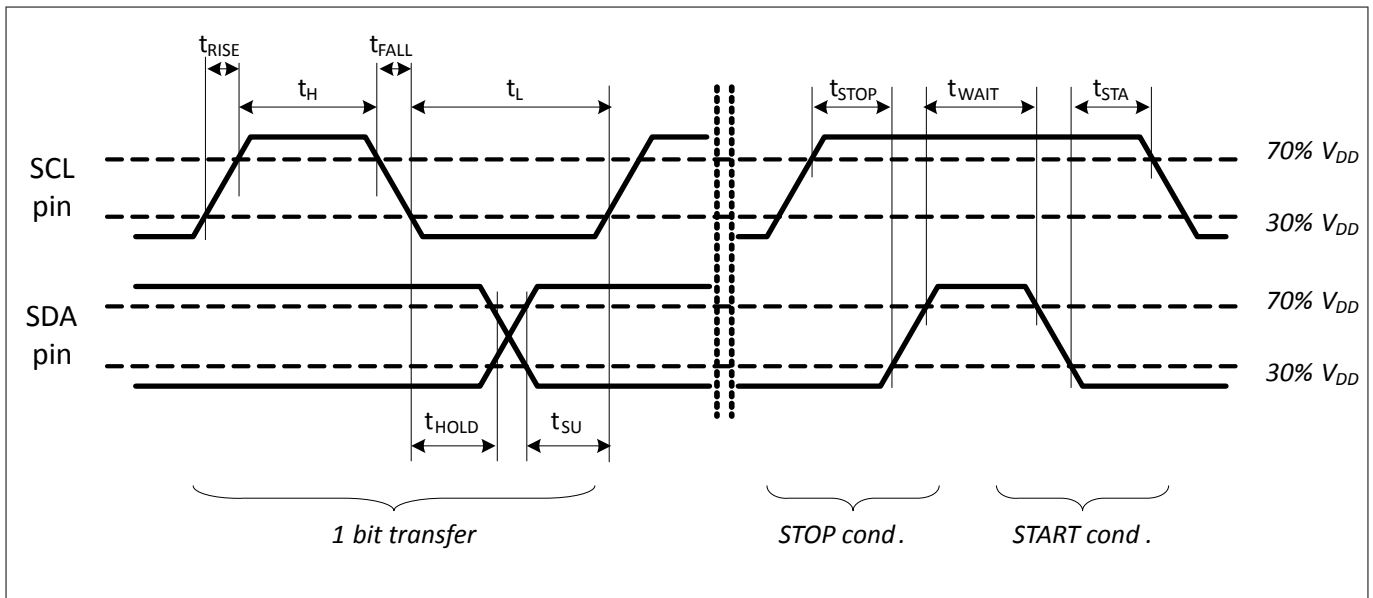

Figure 8 I²C timing specification

Package information

3 Package information

3.1 Package parameters

Table 16 Package parameters

Parameter	Symbol	Values			Unit	Notes
		Min.	Typ.	Max.		
Thermal resistance ²¹⁾ Junction ambient	R_{thJA}	–	–	200	K/W	Junction to air for PG-TSOP-6-6-8
Thermal resistance Junction lead	R_{thJL}	–	–	100	K/W	Junction to lead for PG-TSOP-6-6-8
Soldering moisture level ²²⁾	MSL 1					260°C

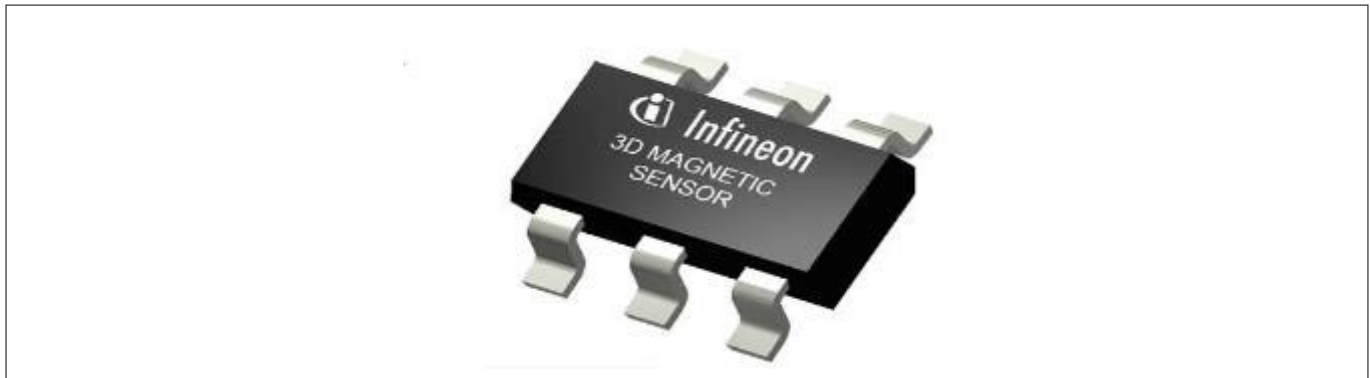

Figure 9 Image of TLE493D-P2B6 in TSOP6

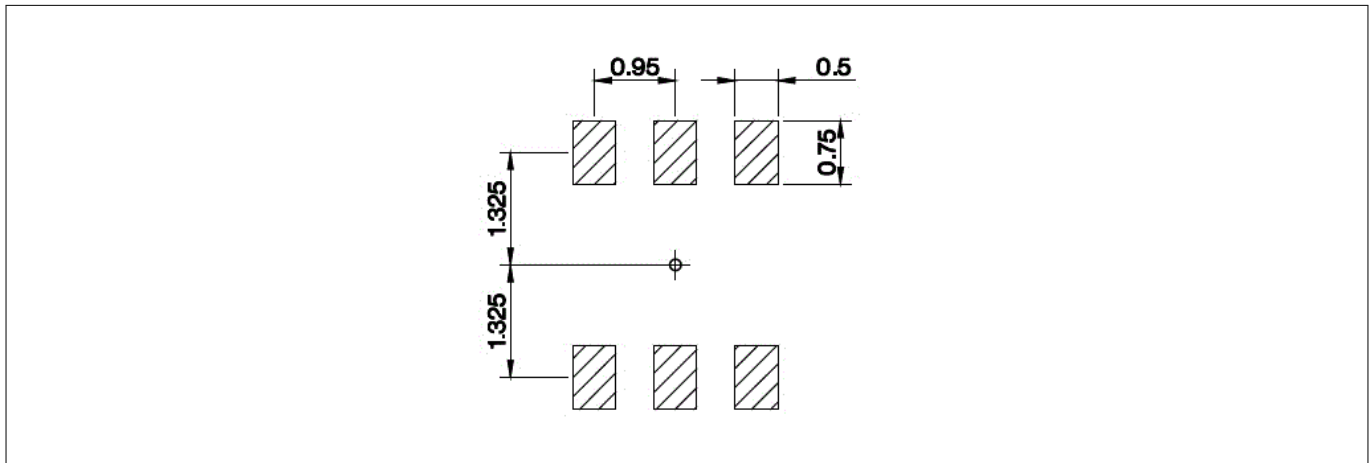

Figure 10 Footprint PG-TSOP6-6-8 (compatible to PG-TSOP6-6-5, all dimensions in mm)

²¹ According to Jedec JESD51-7

²² Suitable for reflow soldering with soldering profiles according to JEDEC J-STD-020D.1 (March 2008)

Package information

3.2 Package outlines

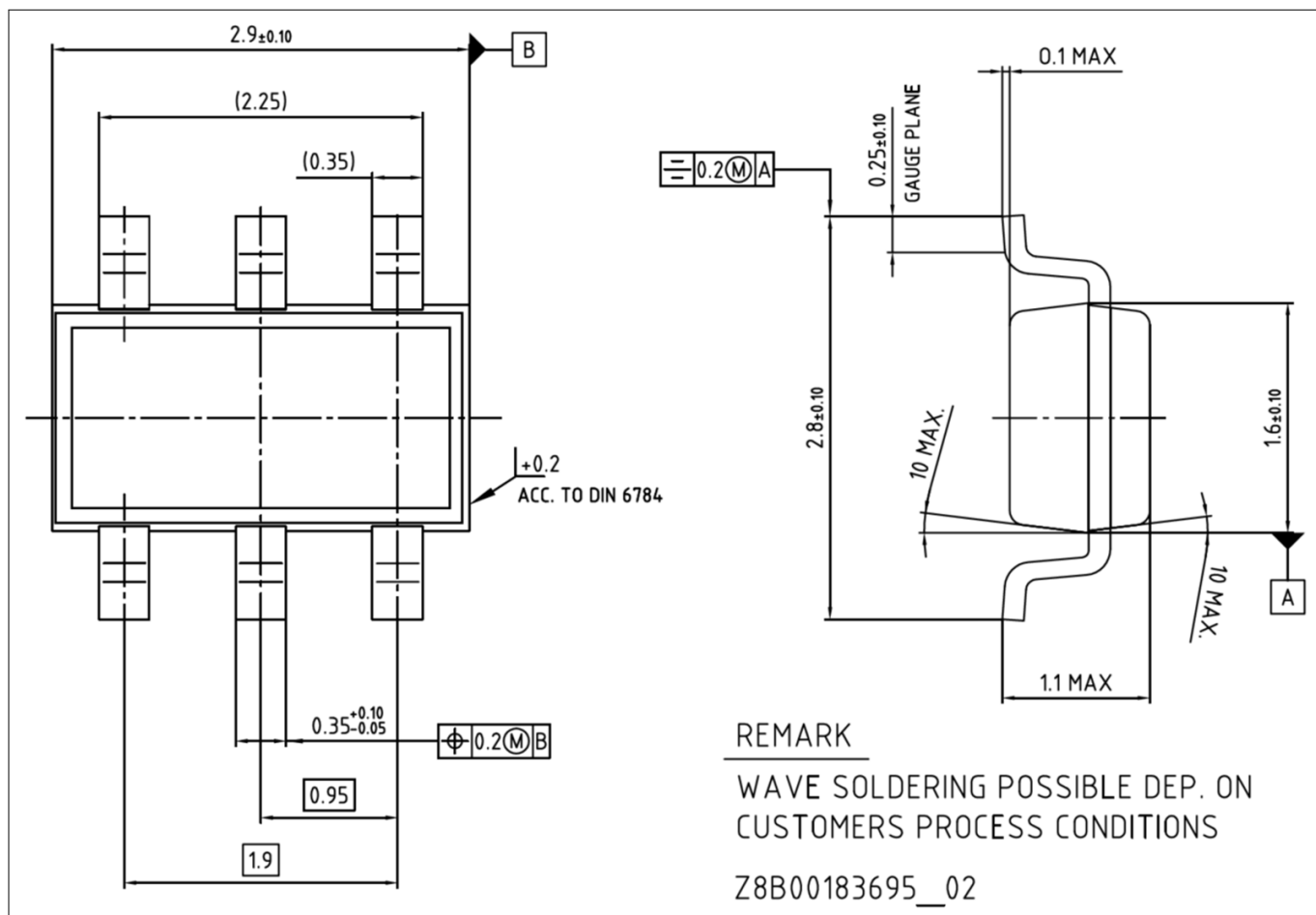

Figure 11 Package outlines (all dimensions in mm)

Revision history

Revision history

Document version	Date of release	Description of changes
V1.0	2021-01-12	Initial release

Trademarks

All referenced product or service names and trademarks are the property of their respective owners.

Edition 2021-01-12

Published by
Infineon Technologies AG
81726 Munich, Germany

© 2021 Infineon Technologies AG
All Rights Reserved.

Do you have a question about any
aspect of this document?
Email: erratum@infineon.com

Document reference
IFX-xtl1604393071312

IMPORTANT NOTICE

The information given in this document shall in no event be regarded as a guarantee of conditions or characteristics ("Beschaffenhheitsgarantie").

With respect to any examples, hints or any typical values stated herein and/or any information regarding the application of the product, Infineon Technologies hereby disclaims any and all warranties and liabilities of any kind, including without limitation warranties of non-infringement of intellectual property rights of any third party.

In addition, any information given in this document is subject to customer's compliance with its obligations stated in this document and any applicable legal requirements, norms and standards concerning customer's products and any use of the product of Infineon Technologies in customer's applications.

The data contained in this document is exclusively intended for technically trained staff. It is the responsibility of customer's technical departments to evaluate the suitability of the product for the intended application and the completeness of the product information given in this document with respect to such application.



WARNINGS

Due to technical requirements products may contain dangerous substances. For information on the types in question please contact your nearest Infineon Technologies office.

Except as otherwise explicitly approved by Infineon Technologies in a written document signed by authorized representatives of Infineon Technologies, Infineon Technologies' products may not be used in any applications where a failure of the product or any consequences of the use thereof can reasonably be expected to result in personal injury.

Looking for pricing, stock, or lifecycle information?

Click below to explore more details on WIN SOURCE:

-  [View TLE493DP2B6A2HTSA1 on WIN SOURCE](#)
-  [Infineon Technologies Information](#)

Optimize Your Supply Chain with WIN SOURCE Solutions

-  Global Sourcing Solution
-  Obsolete Management
-  Cost Control Management
-  Shortage Management
-  Alternative Solution
-  Excess Inventory Management