



**THE DATASHEET OF
SP4001511XTMA1**



SP40T

Tire Pressure Monitoring Sensor

Quality Requirement Category: Automotive

Features

- Patented Glass-Silicon-Glass MEMS pressure sensor with best-in-class media compatibility
- Calibrated pressure sensor for absolute air pressure measurement
- Z-axis accelerometer for motion detection and angular measurement
- Temperature and supply voltage sensors
- Industry-standard 8051 microcontroller with 14K of Flash memory
- System Controller with flexible wake-up and power management features
- RF Transmitter with fractional-N sigma-delta PLL
- Unique firmware functions for determination of angular wheel position, supporting tire localization (APS)
- LF Receiver allows carrier detection and modulated telegram reception

Variants

- SP40Truck (order code SP400-15-11, product code 0015_H) with pressure range up to 1400 kPa

Applications

- Valve based TPMS-Modules
- OEM
- Aftermarket
- Retrofit
- In Tire TPMS Modules

Description

The SP40T provides a very high level of integration, and is optimized to perform all of the functions necessary to implement a state-of-the-art Tire Pressure Monitoring System (TPMS) sensor module. With its integrated micro controller, sensors, and convenient peripherals, the SP40T needs the addition of only a few passive components and a battery to form a complete TPMS sensor assembly.

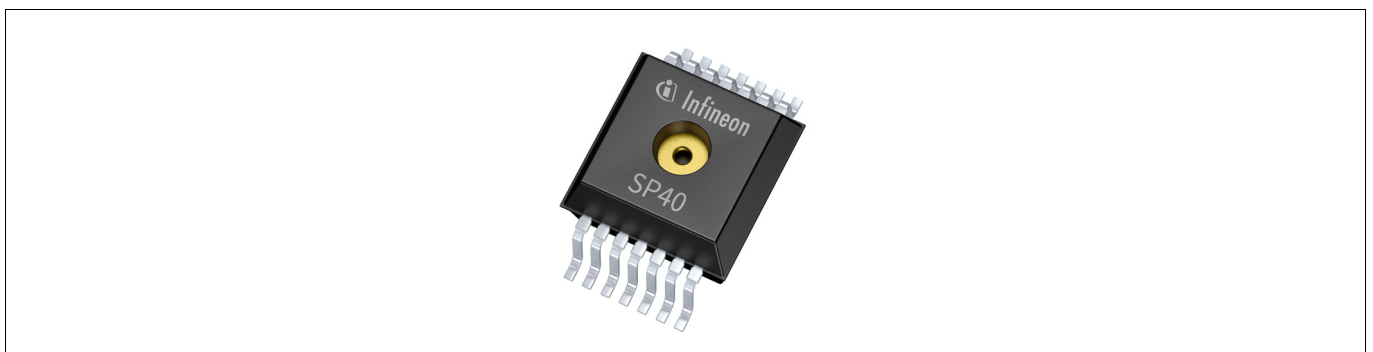

Figure 1 PG-DSOSP-14-82

Table of Contents

	Features	1
	Applications	1
	Description	1
	Table of Contents	2
1	Introduction	4
2	Specification	5
2.1	Absolute Maximum Ratings	5
2.2	Operating Range	7
2.3	Characteristics	8
2.3.1	Pressure Sensor	8
2.3.2	z-axis Acceleration Sensor	9
2.3.3	Temperature Sensor	10
2.3.4	Battery Sensor	10
2.3.5	Thermal Shutdown	10
2.3.6	General Purpose Digital I/O Pins	11
2.3.7	Voltage Monitoring and Power On	12
2.3.8	Flash memory	12
2.3.9	Supply Currents	13
2.3.10	LF-Receiver	14
2.3.11	RF-Transmitter	15
2.3.12	RC Oscillators	16
2.3.13	Wake-up and power-on timing	16
3	Pin Description	18
3.1	Pin Configuration	18
3.2	Pin Description	18
4	Special Features of the SP40PLUS	21
4.1	Operating Modes	21
4.2	Device states	21
4.3	State Transitions	22
5	Functional Descriptions	25
5.1	SP40PLUS Block Diagram	25
5.2	Wake-up Controller	25
5.2.1	Interval Timer	26
5.2.2	LF ON-OFF Timer	27
5.2.3	LF receiver wake-up/resume events	27
5.2.4	General purpose I/O PP2 wake-up/resume event	27
5.2.5	Power-on and under-voltage reset	28
5.2.6	Software reset, watchdog reset and flash error reset	28
5.2.7	Thermal Shutdown	29
5.3	System Controller	29
5.3.1	Sampling Timer	30
5.4	Clock Generators	31
5.5	Core	32
5.5.1	Timer Module	33
5.5.2	Watchdog	34

5.5.3	Hardware CRC	35
5.5.4	I ² C Controller	35
5.5.5	UART Interface	37
5.6	Memories	38
5.6.1	Extended code sector	38
5.6.2	Lock-byte concept overview	39
5.6.3	Flash programming	39
5.6.4	Retention RAM	40
5.6.5	Data RAM and SFRs	40
5.6.6	Retention SFRs	40
5.7	Power Supply and Reset Generator	41
5.7.1	TX battery voltage detector	41
5.8	Measurement Interface	41
5.9	RF transmitter	41
5.9.1	Manchester/Biphase Encoder	42
5.9.2	SD-PLL	44
5.9.3	FSK Modulator	44
5.9.4	Gaussian filter	44
5.9.5	RF Power Amplifier	45
5.9.6	ASK modulator and ASK ramping	45
5.9.7	Crystal Oscillator	46
5.9.8	RF Baud-Rate Generator	47
5.10	RF Transmission Controller	47
5.10.1	SOM and EOM Feature	49
5.10.2	Voltage measurement at end of transmission	50
5.11	LF Receiver	50
5.11.1	LF Analog Front End (AFE)	51
5.11.2	LF Digital baseband (DBB)	51
5.11.3	LF Telegram	54
5.11.4	LF state machine	54
5.12	I/O-Port	58
6	Application Circuit	59
7	Data Sheet Reference Board	61
8	Package Information	65
8.1	Package Outline	65
8.2	Marking	66
8.3	Package axis definition	67
	References	68
	Terminology	69

Introduction**1 Introduction**

Measurements of pressure, acceleration, temperature, and battery voltage are performed under software control, allowing the application software to format and prepare the data for RF transmission. An intelligent system controller provides flexible wake-up capability in order to reduce energy usage. A calibrated Interval Timer is included to permit periodic wake-up of the CPU, which in turn can then perform measurements and transmit data to a receiver. The integrated Z-axis accelerometer may be used by the application software to detect motion and distinguish between parking and driving situation.

The integrated microcontroller is instruction set compatible to the standard 8051 processor and is supported by commercially available C compilers and IDE tool chains. The microcontroller core is supplemented with various peripherals (e.g. hardware Manchester/BiPhase Encoder/Decoder, CRC Generator/Checker, I2C- and UART-interface) that enable an easy implementation of TPMS application software.

For user specific application code the SP40T includes 12k of on-chip flash memory.

Another 2K of on-chip flash in a separated sector (extended code sector) is available, too. The main 12K code sector can be erased independently from the extended sector which allows for boot-loader functionality.

The RF Transmitter block covers both 315 and 434 MHz UHF bands and supports FSK and ASK modulation. The transmitter contains a fractional-N sigma-delta PLL synthesizer which allows for precise control of carrier frequency and accurate FSK frequency modulation. A flexible baseband encoder and advanced power management techniques are used to hold the peak current consumption during RF transmission to a minimum. An integrated autonomous LF Receiver allows the SP40T to receive diagnostic or operating state commands, supporting application features such as pressure-on-demand or tire position localization.

Finally, a comprehensive firmware library supports using all above mentioned hardware blocks effectively. Especially a unique set of Angular Position Sensing (APS) functions allows calculating the instantaneous angular position of the TPMS module relative to the car chassis which may be used for wheel localization on system level.

Specification

2 Specification

2.1 Absolute Maximum Ratings

Table 2-1 Absolute Maximum Ratings

Parameter	Symbol	Values			Unit	Note or Test Condition	Number
		Min.	Typ.	Max.			
Max. Supply Voltage	V_{DDmax}	-0.3		+3.8	V		1.1
ESD robustness HBM	V_{ESD_HBM}	-2000		2000	V	All pins according to EIA/JESD22-A114-B	1.2
		-4000		4000	V	PAOUT pin according to EIA/JESD22-A114-B	1.3
ESD robustness CDM	V_{ESD_CDM}	-500		500	V	All pins (According to ESDA STM 5.3.1)	1.4
		-750		750	V	Corner pins (According to ESDA STM 5.3.1)	1.5
Latch up	I_{LU}	-100		+100	mA	AEC-Q100 (transient current)	1.6
Input voltage	V_{In}	-0.3		$V_{DD} + 0.3$	V	PP0, PP1, PP2, PP3	1.7
		-0.3		+1.8	V	LFP, LFN, XIN	1.8
	V_{In_LF}	-0.3		+0.3	V	Differential input at LFP and LFN	1.9
Peak voltage at PAOUT pin	V_{PAOUT_peak}			8	V	The matching network must be designed such that the peak-voltage at PA does not exceed this value	1.10
Output short-circuit capability ¹⁾	V_{SC}	0		3.8	V	Short to VDD, GND or neighbor pin for max. 10min at VDD=3.8V. Note: VDDREG and XOUT must not be shorted to VDD	1.11
DC current	I_{DC}	-10		10	mA	all pins	1.13
Over pressure	p_{max}			2000	kPa	static load	1.14
Burst pressure	p_{burst}	2000			kPa	10 times 1 sec	1.15
Static acceleration	a_{static}			3000	g	Device unpowered. Tested in z-direction.	1.16

Specification

Table 2-1 Absolute Maximum Ratings

Parameter	Symbol	Values			Unit	Note or Test Condition	Number
		Min.	Typ.	Max.			
Mechanical shock	a_{shock}			6000	g	0.3 ms half sine pulses. 5 shocks in +/- x,y,z-direction, respectively. Device unpowered.	1.17
Storage temperature	T_{storage}	-50		+150	°C	Maximal 1000 hours accumulated over lifetime between 125°C and 150°C. Device not powered. Temperature cycling only allowed between -40°C and 125°C.	1.18

1) Refers to following pins: PP0 to PP3 if configured as output, XOUT, VDDREG, PAOUT and VDDPA. For input pins see parameter input voltage.

Note: **Absolute maximum ratings are values beyond recommended operating conditions. They describe those conditions which the device can withstand for some limited time. After exposure to maximum ratings the device will remain functional, but the reliability is no longer ensured.**

Specification

2.2 Operating Range

The operating range defines the ambient conditions where the device operates as specified. Certain specified parameters in this data sheet may depend on additional operating conditions. These additional conditions are indicated in the corresponding sections.

Table 2-2 Operating Range

Parameter	Symbol	Values			Unit	Note or Test Condition	Number
		Min.	Typ.	Max.			
Supply Voltage ¹⁾	V_{DD}	VUVRA	–	3.6	V	Device not in power down state	3.1
		VUVRPD	–	3.6	V	Device in power down state	3.2
Ambient Temperature	$T_{Operating}$	-40	–	125	°C	Normal Operation	3.3
	T_{Flash}	-20	–	90	°C	FLASH programming/erasing	3.4
Extended Temperature Range	T_{EXT}	-50		150	°C	Thermal shutdown functional. $V_{DD} = V_{UVRA}$ to 3.6 V. Exposure to 125°C...150°C maximal 24h over lifetime	3.5
z-axis Acceleration	$a_{Operating}$	-1600	–	1600	g	Exceeding this acceleration will result in a higher pressure error as specified.	3.6

1) Supply voltage must be connected to VDDBAT pin.

Specification

2.3 Characteristics

2.3.1 Pressure Sensor

Table 2-3 Pressure Sensor 1400kPa Range¹⁾²⁾

Parameter	Symbol	Values			Unit	Note or Test Condition	Number
		Min.	Typ.	Max.			
Input Pressure Range	p_{in}	100		1400	kPa		5.1
Random Error	p_{random}	-1.37		1.37	kPa	95% of all measurements	5.2
ADC resolution	p_{ADC_res}			1	kPa/ LSB	1 LSB of a raw measurement corresponds to 1 kPa or less	5.3
Measurement Error ³⁾	$p_{Error\ 100-1100}$	-19		19	kPa	0°C to +60°C	5.4
		-25		25	kPa	-20°C to 0°C +60°C to +100°C	5.5
		-30		30	kPa	-40°C to -20°C +100°C to +125°C	5.6
	$p_{Error\ 1100-1400}$	-25		25	kPa	0°C to +60°C	5.10
		-30		30	kPa	-20°C to 0°C +60°C to +100°C	5.11
		-35		35	kPa	-40°C to -20°C +100°C to 125°C	5.12

- 1) Based on averaging two raw values for each measurement
- 2) Exceeding the maximum z-axis acceleration (parameter 3.6) as defined in the operating range will result in a higher pressure measurement error than specified
- 3) The measurement error is understood as total error, including random error (noise)

Specification

2.3.2 z-axis Acceleration Sensor

Table 2-4 z-axis Acceleration Sensor

Parameter	Symbol	Values			Unit	Note or Test Condition	Number
		Min.	Typ.	Max.			
Input acceleration Range	a_{in}	-20		355	g	Selectable by firmware function	12.1
		-355		20	g		12.2
Total Acceleration Error ¹⁾	a_{err_tot}	-6.5 (-3.0)		+6.5 (+3.0)	g	$ a_{in} =0g \dots 20g$ $T = -40^{\circ}C \dots 90^{\circ}C$	12.3
		-8.5 (-5.0)		+8.5 (+5.0)	g	$ a_{in} =0g \dots 20g$ $T = 90^{\circ}C \dots 125^{\circ}C$	12.4
		-8.5 (-5.0)		+8.5 (+5.0)	g	$ a_{in} >20g \dots 100g$ $T = -40^{\circ}C \dots 90^{\circ}C$	12.5
		-10.5 (-7.0)		+10.5 (+7.0)	g	$ a_{in} >20g \dots 100g$ $T = 90^{\circ}C \dots 125^{\circ}C$	12.6
		-12.5 (-9.0)		+12.5 (+9.0)	g	$ a_{in} >100g \dots 200g$ $T = -40^{\circ}C \dots 90^{\circ}C$	12.7
		-14.5 (-11.0)		+14.5 (+11.0)	g	$ a_{in} >100g \dots 200g$ $T = 90^{\circ}C \dots 125^{\circ}C$	12.8
		-22.5 (-19.0)		+22.5 (+19.0)	g	$ a_{in} >200g \dots 355g$ $T = -40^{\circ}C \dots 90^{\circ}C$	12.9
		-24 (-20.5)		+24 (+20.5)	g	$ a_{in} >200g \dots 355g$ $T = 90^{\circ}C \dots 125^{\circ}C$	12.10
Random error of acceleration compensated values	$a_{rnd_comp_16}$	-0.35		+0.35	g	99.7% of all measurements. Averaging of 16 ADC-samples. No external noise sources present.	12.11
ADC resolution	a_{ADC_res}	0.057		0.175	g/ LSB	1 LSB of a raw measurement corresponds to minimal 0.057g and maximal 0.175g	12.14
Random error of acceleration raw values	$a_{rnd_raw_16}$	-4		+4	LSB	99.7% of all measurements. Averaging of 16 ADC-samples. No external noise sources present.	12.16
Accelerometer resonance frequency	f_{res_acc}	5.1	6	6.9	kHz	Mechanical excitation of the SP40T in this frequency range must be avoided (e.g. PCB sawing process)	12.17

1) Total error specifications are based on averaging 16 raw values for each measurement and they include random error (noise). The total error may be reduced by 3.5g by periodically, at least every 3 months, using the automatic acceleration offset compensation function `Lib_Comp_Auto_Acc_Offset()`. The reduced errors are put into brackets.

Specification

2.3.3 Temperature Sensor

Table 2-5 Temperature Sensor

Parameter	Symbol	Values			Unit	Note or Test Condition	Number
		Min.	Typ.	Max.			
Measurement range	T_{range}	-40		+125	°C		14.1
Measurement error ¹⁾	T_{Error}	-3		+3	°C		14.2
Random error	T_{random}	-1		+1	°C	95% of all measurements	14.4

1) The measurement error is understood as total error, including random error (noise)

2.3.4 Battery Sensor

Table 2-6 Battery Sensor

Parameter	Symbol	Values			Unit	Note or Test Condition	Number
		Min.	Typ.	Max.			
Measurement range	V_{range}	VUVRA		3.6	V	see Table 2-10 for V_{UVRA}	15.1
Measurement error ¹⁾	V_{Error}	-3	-	+3	%	percentage of measurement value	15.2

1) The measurement error is understood as total error, including random error (noise)

2.3.5 Thermal Shutdown

Table 2-7 Thermal Shutdown

Parameter	Symbol	Values			Unit	Note or Test Condition	Number
		Min.	Typ.	Max.			
Thermal Shutdown HOT threshold	$T_{\text{HOT TH}}$	119	122	125	°C		16.1
Thermal Shutdown HOT release	$T_{\text{HOT RE}}$	115	120	123.5	°C		16.2
Hysteresis	T_{HYST}	1.5		4	°C		16.3
Thermal Shutdown COLD threshold	$T_{\text{COLD TH}}$	-40	-37	-34	°C		16.4
Thermal Shutdown COLD release	$T_{\text{COLD RE}}$	-38.5	-35	-30	°C		16.5

Specification

2.3.6 General Purpose Digital I/O Pins

Table 2-8 Digital I/O Pins - Operating Range

Parameter	Symbol	Values			Unit	Note or Test Condition	Number
		Min.	Typ.	Max.			
Digital Pin Output Current	$I_{out\ DIG}$	-4		4	mA	Pins PP0 to PP3	17.1
Digital Pin Input High Voltage	V_{IH}	$0.8V_{DD}$			V	functional	17.2
		$V_{DD} - 0.05$			V	for lowest current consumption ¹⁾	17.3
Digital Pin Input Low Voltage	V_{IL}			$0.2V_{DD}$	V	functional	17.4
				50	mV	for lowest current consumption	17.5

1) If the digital I/O pins are left open and the internal pull resistors are activated the +/-50mV criterion is fulfilled

Table 2-9 Digital I/O Pins - Electrical Characteristics

Parameter	Symbol	Values			Unit	Note or Test Condition	Number
		Min.	Typ.	Max.			
Digital Pin-Output High Voltage	V_{OH}	$V_{DD} - 0.3$			V	at 1 mA load current	18.1
Digital Pin-Output Low Voltage	V_{OL}			0.3	V		18.2
Digital Pin Input Capacitance	C_{in}			10	pF	PP0, PP1 and PP3	18.3
				20	pF	PP2	18.4
Digital Pin Input current (PP0, PP1, PP3)	$I_{in_PP0_1_3}$	-1		1	μA	PP0, PP1, PP3 configured as input	18.5
Digital Pin Input current (PP2)	I_{in_PP2}	-1		1	μA	PP2 configured as input T = -40°C...+90°C	18.6
		-1.5		1.5	μA	PP2 configured as input T = +90°C...+125°C	18.7

Specification

2.3.7 Voltage Monitoring and Power On

Table 2-10 Voltage Monitoring and Power On

Parameter	Symbol	Values			Unit	Note or Test Condition	Number
		Min.	Typ.	Max.			
Under Voltage Reset (measured at VDDBAT pin)	V_{UVRA}	1.6		1.7	V	applies in run- and idle-state and if RF transmission is ongoing ¹⁾	19.1
	V_{UVRPD}	1.2		1.6	V	applies in all other device states	19.2
Reset Release Threshold ²⁾	V_{THR}	1.8		1.9	V	applies for a reset triggered by under voltage and power-on reset	19.3
RF Undervoltage ³⁾ Warning Level	V_{MIN}	1.8		1.9	V		19.4
Brown-out Detection Threshold ⁴⁾	V_{THR_BOD}	1.15		1.25	V		19.5

1) During TX-interframe in TX-low-power, when the analog circuits are switched off, 19.1 does not apply

2) The device will be released from undervoltage reset or power-on reset only if voltage at VDDBAT pin exceeds V_{THR}

3) A flag is set if voltage at VDDBAT pin falls below V_{MIN} during RF transmission

4) The brown-out detector monitors the internal 1.5V domain

2.3.8 Flash memory

Table 2-11 Flash Memory¹⁾

Parameter	Symbol	Values			Unit	Note or Test Condition	Number
		Min.	Typ.	Max.			
Flash memory data retention time	$t_{Ret\ Flash}$	10			y	Defect rate < 1ppm over lifetime.	20.1
Flash write cycles	N_{write}			100			20.2
Flash line write time	t_{write_line}			6	ms	Including time for verification. I ² C Baud-rate = 400 kbit/s	20.3

1) Endurance, data retention, and operational life qualified according AEC-Q100-005D1

Specification

2.3.9 Supply Currents

Table 2-12 Supply Currents at 3.0V supply voltage

Parameter	Symbol	Values			Unit	Note or Test Condition	Number
		Min.	Typ.	Max.			
Supply current in power down state ¹⁾	I_{PVD_3V}		245	540	nA	+25°C	21.1
			8.5		μA	+125°C	21.2
			0.15		μA	-40°C	21.3
Supply current in idle state (CPU gated off)	I_{IDLE_3V}		280	400	μA	+25°C	21.4
			400		μA	+125°C	21.5
			280		μA	-40°C	21.6
Supply current in run state ²⁾	I_{RUN_3V}		0.85	1.05	mA	+25°C	21.7
			0.95		mA	+125°C	21.8
			0.83		mA	-40°C	21.9
Supply current at thermal shutdown ³⁾	I_{TSD_3V}		85	116	μA	+125°C	21.10
			62	110	μA	-40°C	21.11
LF-receiver supply current in LF carrier detection mode (digital filter off) ⁴⁾	I_{LFCD_3V}		3.3	4	μA	+25°C	21.12
			10		μA	+125°C	21.13
			3.5		μA	-40°C	21.14
LF-receiver supply current in LF carrier detection mode (digital filter on) ⁴⁾	$I_{LFCDFilter_3V}$		4	6	μA	+25°C	21.15
			11		μA	+125°C	21.16
			4		μA	-40°C	21.17
LF-receiver supply current in LF data reception mode ⁴⁾	I_{LF_3V}		3.85	6	μA	+25°C	21.18
			11		μA	+125°C	21.19
			4		μA	-40°C	21.20
Supply current at RF-transmission CW or FSK CPU off ⁵⁾	I_{RFTX_3V}		5.5	7	mA	315MHz, -40...+125°C	21.21
			5.7	7	mA	434MHz, -40...+125°C	21.22
Supply current during RF interframe timing (CPU off)	I_{TXIF_3V}		2.1	12	μA	+25°C	21.24
			34		μA	+125°C	21.25
			1.8		μA	-40°C	21.26
Supply current in deep idle state	I_{DEEP_3V}		2.1	12	μA	+25°C	21.27
			25	100	μA	+125°C	21.28
			1.7		μA	-40°C	21.29

1) PP0, PP1, PP2, PP3 not connected

2) Measured while code is running from flash, executing a mix of read/write operations on retention RAM, SFRs and RAM

3) I_{TSD} is the always ON current. Average current for clocked operation is $I_{TSD_avg} = I_{PVD} + (I_{TSD} - I_{PVD}) * 2.9 / 16 / Interval_Mul_16ms$

4) The LF-receiver supply currents at each temperature are measured by subtracting the power down current with LF-Receiver being turned off from the power down current with LF-Receiver being activated in the specific mode.

Specification

5) Measured with the Data Sheet Reference Board, 50 Ohm RF output terminated with 50Ohm, VDDPA = 2.1V

2.3.10 LF-Receiver

Table 2-13 LF Receiver Operating Conditions

Parameter	Symbol	Values			Unit	Note or Test Condition	Number
		Min.	Typ.	Max.			
LF Carrier Frequency ¹⁾	f_{LF}	115	125	135	kHz		22.1
LF Data Rate	DR_{LF}	3.8	3.9	4.2	kbit/s		22.2
LF Data Duty Cycle	DC_{LF}	45	50	55	%		22.3
LF Data amplitude change speed	AC_{SLF}			1.5	Vpp/s	Valid for input signals up to 10mVpp	22.4

1) LF sensitivity levels are only valid for the specified carrier frequency range.

Table 2-14 LF Receiver Characteristics

Parameter	Symbol	Values			Unit	Note or Test Condition	Number
		Min.	Typ.	Max.			
Input differential capacitance	$C_{LF\ diff}$	2.5	3.9	10	pF	at 125kHz	23.1
Input differential resistance	$R_{LF\ diff}$	1			MOhm	at 125kHz, AGC inactive, -40°C to 90°C	23.4
		$1-(T/°C -90)/70$			MOhm	at 125kHz, AGC inactive, 90°C ≤ T ≤ 125°C	23.5
LF Receiver settling time after power on	$t_{ON_Set.}$			3.9	ms	After receiver power-on	23.6

Table 2-15 LF Receiver Characteristics (Data Reception Mode)¹⁾²⁾

Parameter	Symbol	Values			Unit	Note or Test Condition	Number
		Min.	Typ.	Max.			
LF Data Threshold settling time	$t_{Settling}$			2	ms	During LF- telegram preamble	24.1
LF Telegram Detection Sensitivity	S_{nodet}	0.1			mVpp		24.2
	S_{det}			1.3	mVpp	-20°C to 90°C	24.3
				2.5	mVpp	-40°C to 125°C	24.4

1) LF telegram detection sensitivity specified for 100% modulation depth.

2) Specified sensitivities require calling Lib_LF_Sensitivity() in application code, [1].

Specification

Table 2-16 LF Receiver Characteristics (Carrier Detection Mode)¹⁾

Parameter	Symbol	Values			Unit	Note or Test Condition	Number
		Min.	Typ.	Max.			
LF Carrier Detection Sensitivity	S_{nodet}	0.33			mVpp		25.1
	S_{det}			3.35	mVpp		25.2
Carrier Detector Filter Time ²⁾	$t_{\text{CD}1}$	140	200	240	μs		25.9
	$t_{\text{CD}2}$	350	500	650	μs		25.10
	$t_{\text{CD}3}$	700	1000	1300	μs		25.11

1) Specified sensitivities require calling Lib_LF_Sensitivity() in application code, [1].

2) Specified carrier detector filter times require calling Lib_LF_Pulse_Width() in application code, [1].

2.3.11 RF-Transmitter

Table 2-17 RF Transmitter Characteristics¹⁾

Parameter	Symbol	Values			Unit	Note or Test Condition	Number
		Min.	Typ.	Max.			
Transmit Frequency	f_{TX}	314		316	MHz		28.1
		433		435	MHz		28.2
RF Data Rate	DR_{RF}			20	kbit/s	Manchester Coded	28.3
RF Data Rate tolerance ²⁾	$DR_{\text{RF TOL}}$	-1		1	%		28.4
RF Output Power ³⁾	P_{RF}	4	5	6	dBm	$2.5\text{V} \leq V_{\text{DD}} \leq 3.6\text{V}$ +25 to +60 °C	28.5
		3		7	dBm	$1.8\text{V} \leq V_{\text{DD}} < 2.5\text{V}$ -40 to 0 °C	28.6
		3		7	dBm	$2.5\text{V} \leq V_{\text{DD}} \leq 3.6\text{V}$ -40 to +25 °C	28.7
		3		6	dBm	$2.5\text{V} \leq V_{\text{DD}} \leq 3.6\text{V}$ +60 to +125 °C	28.8
		2		6	dBm	$1.8\text{V} \leq V_{\text{DD}} < 2.5\text{V}$ 0 to +125 °C	28.9
FSK frequency shift		0	+/-40	+/-75	kHz	programmable see [2]	28.10
RF Data Duty Cycle	DC_{RF}	45	50	55	%	valid for FSK ⁴⁾ and ASK ⁵⁾	28.11
ASK Modulation depth	MD_{RF}	90			%		28.12

1) Parameters have been measured with the Data Sheet Reference Board at the 50 Ohm RF output.

2) Specification applies for following data-rates: 4096, 4200, 9600, 10000 and 19200 Baud. For other data-rates the tolerance may increase to up to +/- 1.5%.

3) Valid for voltage at pin VDDPA = 2.1V

4) FSK duty cycle is characterized by eye-diagram evaluation

5) ASK duty cycle is defined at -3dB of the maximum RF power during ASK on

Specification

Table 2-18 RF Crystal Oscillator

Parameter	Symbol	Values			Unit	Note or Test Condition	Number
		Min.	Typ.	Max.			
Crystal Frequency	f_{XTAL}	25.920	26	26.080	MHz		29.1
Crystal oscillator drive current	I_{Xtal_drive}	1.5			mA	This parameter reflects the driving capability of the crystal oscillator	29.2
Crystal Oscillator startup time	t_{Xtal_start}			1	ms	For crystals recommended by IFX	29.3

2.3.12 RC Oscillators

Table 2-19 RC Oscillator Characteristics

Parameter	Symbol	Values			Unit	Note or Test Condition	Number
		Min.	Typ.	Max.			
Temperature drift of 2.2kHz oscillator	TD2k	-0.075		+0.075	%/K		30.1
Total tolerance of 2.2kHz oscillator ¹⁾	TOL2k _{tot}	-30		30	%	-40 to +125°C and over lifetime	30.2
Temperature drift of 90kHz oscillator	TD90k	-0.05		+0.05	%/K		30.4
Total tolerance of 90kHz oscillator ²⁾	TOL90k _{tot}	-5		5	%	-40 to +125°C and over lifetime	30.5
Temperature drift of 12MHz oscillator	TD12M	-0.05		+0.05	%/K		30.7
Total tolerance of 12MHz oscillator	TOL12M _{tot}	-8		8	%	-40 to +125°C and over lifetime	30.8

- 1) The 2.2kHz oscillator is the clock source for the interval timer and the ON-OFF timer. The timers can be calibrated with firmware functions. The calibration error is reported in the description of the FW function. This error is only valid if temperature stays constant.
- 2) The 90kHz oscillator is the clock source for the sampling timer and the interframe timer. The timers can be calibrated with firmware functions. The calibration error is reported in the description of the FW function. This error is only valid if temperature stays constant.

2.3.13 Wake-up and power-on timing

Specification

Table 2-20 Wake-up and power-on timing

Parameter	Symbol	Values			Unit	Note or Test Condition	Number
		Min.	Typ.	Max.			
Power on time	t_{ini}			10.2	ms	Time after exceeding V_{THR} until start of I2C handler	31.1
Normal mode delay time	t_{NM_delay}			110	μ s	Time after I2C command for normal mode sent until application code execution start	31.2
Resume from deep idle time	t_{resume}			750	μ s	Time from resume event during deep-idle to application code execution start.	31.3
Mode selection time	t_{MS}	2.1	2.8	4.2	s	see Chapter 5.2.5	31.4
LF Wake-up time ¹⁾	$t_{LF\ wake-up}$			5.3	ms	Time from LF wake-up event during power-down to application code execution start.	31.5
IT Wake-up time ¹⁾	$t_{IT\ wake-up}$			6	ms	Time from interval timer elapsed during power-down to application code execution start.	31.6
PP2 Wake-up time ¹⁾	$t_{PP2\ wake-up}$			6	ms	Time from level-change detected at PP2 during power-down to application code execution start.	31.7

1) Note: the device stays in power-down most of the wake-up time and only 550 μ s(max) in run-state before application code execution starts

Pin Description

3 Pin Description

3.1 Pin Configuration

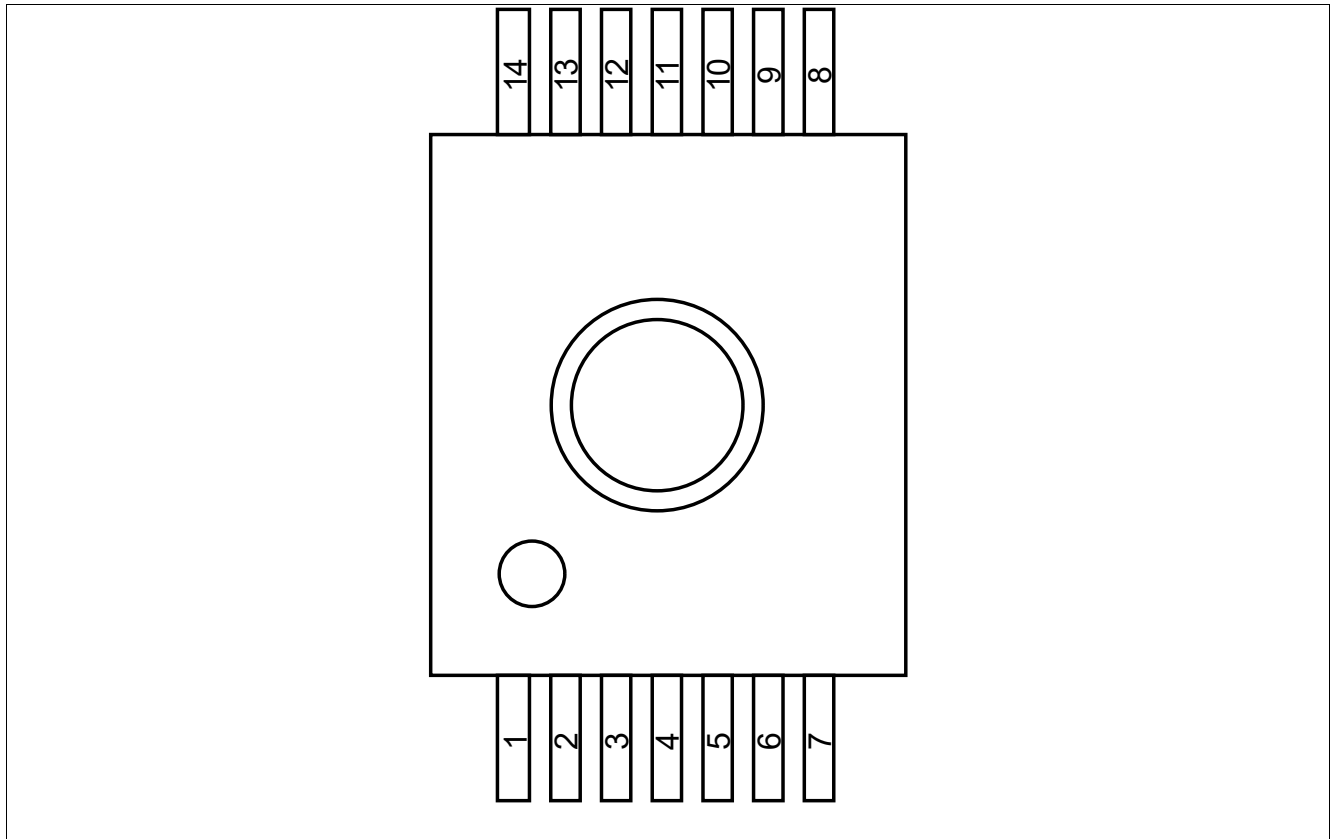

Figure 2 Pin Configuration

3.2 Pin Description

Table 3-1 Pin Description

Pin No.	Name	Pin Type	Buffer Type	Function
1	SCL/PP0	Digital I/O		General Purpose-I/O I²C Clock
2	SDA/PP1	Digital I/O		General Purpose-I/O I²C Data
3	PP2	Digital I/O		General Purpose-I/O UART RX data

Pin Description

Table 3-1 Pin Description (cont'd)

Pin No.	Name	Pin Type	Buffer Type	Function
4	GNDD ¹⁾	Supply		Digital Ground
5	PP3	Digital I/O		General Purpose-I/O UART TX data
6	XIN	Analog		Crystal oscillator input
7	XOUT	Analog		Crystal oscillator output
8	LFN	Analog		LF receiver negative input
9	LFP	Analog		LF receiver positive input

Pin Description

Table 3-1 Pin Description (cont'd)

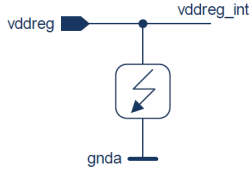
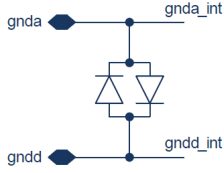
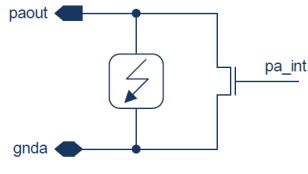
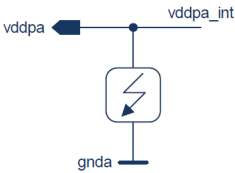
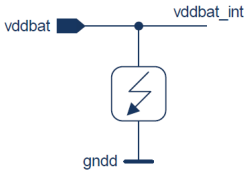
Pin No.	Name	Pin Type	Buffer Type	Function
10	VDDREG	Supply		Regulated voltage output (1.5V)²⁾
11	GND ¹⁾	Supply		Analog Ground
12	PAOUT	Analog output		RF power amplifier output
13	VDDPA	Analog output		Regulated voltage for PA
14	VDDBAT	Supply		Power supply

1) GNDD and GNDA are shorted internally via leadframe

2) Note: this pin is only intended for stabilization of the internal voltage of the SP40T by an external capacitor. It must not be used as external current source.

Special Features of the SP40T

4 Special Features of the SP40T

4.1 Operating Modes

Apart from normal operating mode the SP40T provides additional operating modes for debugging and programming purposes. These additional operating modes can be selected by sending a proper I²C command within a specified time interval after power on reset (POR). The I²C command starts with the device address (6C_H) followed by a code for the operating mode to be selected. If the SP40T does not receive any I²C command after POR or a wrong command it starts up in normal operating mode (“Normal mode”).

Table 4-1 Operating Modes Overview

Operating mode	Device controlled by	Short Description	I ² C command ¹⁾
Normal mode	application code	Normal operating mode for TPMS application	9876 _H
Program mode	external I ² C-Master	Used for programming application code and user configuration data. Additional I ² C commands allow reading sensor measurement values.	1F5A _H
Debug mode	external I ² C-Master	Used for application code development. Commands for RAM read/write, program counter manipulation, execute single step and run until breakpoint/interrupt are available.	FEDC _H

1) The complete I²C sequence is: [0x6C] [command high byte] [command low byte]

4.2 Device states

In normal operation mode the SP40T can be switched into several device states which differ in the number of enabled circuit blocks. For lowest power consumption unused blocks are disconnected from power supply, hence not even idle currents remain.

Table 4-2 Device states overview

Device state	Short description	Important activated blocks
Run state	application code execution.	<ul style="list-style-type: none"> • CPU with 12 MHz RC-oscillator • All other blocks can be activated if needed
Idle state ¹⁾	No code execution. Device is waiting for a wake-up/resume event. Fast recovery on wake-up/resume event.	<ul style="list-style-type: none"> • 12 MHz CPU clock and CPU timer (CPU disabled) • Optional: ADC • Optional: TX-state machine, RF-transmitter • Optional: Timer 0/1 • Optional: LF Receiver with 90 kHz oscillator
Deep idle state ²⁾	No code execution. Device is waiting for a resume event from sampling timer or wake-up event. Intended for equidistant acceleration raw measurements.	<ul style="list-style-type: none"> • Wake-up controller with 2.2kHz RC-oscillator • 90 kHz oscillator • System controller • Optional: LF-receiver
Power-down state	No code execution. Device is waiting for a wake-up event. Lowest current consumption.	<ul style="list-style-type: none"> • Wake-up controller with 2.2kHz RC-oscillator • Optional: LF-receiver with 90 kHz oscillator

Special Features of the SP40T

Table 4-2 Device states overview (cont'd)

Device state	Short description	Important activated blocks
TX low power state	Power-down state where TX state-machine can be operated. Device wakes-up/resumes on interval-timer elapsed or transmission end. Other events are postponed.	<ul style="list-style-type: none"> Wake-up Controller with 2.2kHz RC-oscillator Optional: LF Receiver with 90 kHz oscillator 90kHz oscillator TX state machine RF-transmitter when needed by TX state machine
Thermal shutdown state ³⁾	Almost all circuits shut off. Resume only if temperature returns to normal operating range.	<ul style="list-style-type: none"> Temperature detector Wake-up Controller with 2.2kHz RC-oscillator

- 1) In idle state the CPU is halted. When device resumes from idle code execution immediately continues behind the point of entering idle state.
- 2) In deep idle the CPU is shut off. When device resumes from deep idle code execution restarts from reset vector.
- 3) In thermal shutdown the CPU is shut off. When device resumes from thermal shutdown code execution restarts from reset vector.

4.3 State Transitions

Figure 4-1 shows the possible state transitions in normal mode. The central device state is run state because only in run state the state transitions can be configured. Entering other states from run state is controlled by application code, either by calling firmware functions [1] or setting control bits [2]. State transitions from other states are controlled by hardware events, e.g. timer events or LF receiver events.

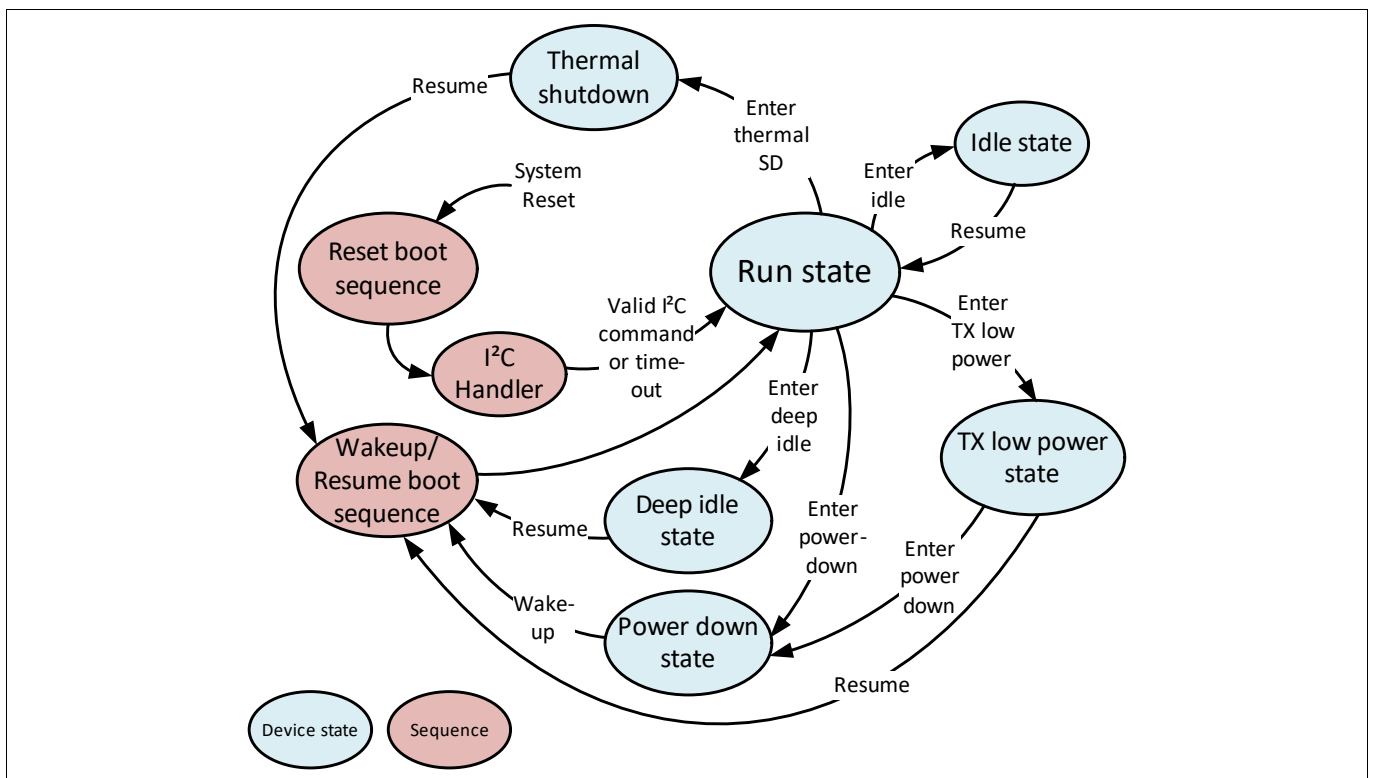

Figure 4-1 State transitions in normal mode

Table 4-3 gives an overview of the event sources and the corresponding indicator flags. For each indicator flag there is an accordant masking flag. However, it does not matter if an event is masked out or not, the indicator flag will always be set if the event occurs, provided that the indicator register is powered. The masking flag only

Special Features of the SP40T

determines if the event generates a wake-up/resume. Because not all event sources and all registers are powered in all power states the actual event indicator flag behavior depends on power state. This behavior is also reported in [Table 4-3](#). Furthermore the table shows if the event will generate a resume/wake-up from the respective power state. Especially in TX low power state certain wake-up/resume events are blocked by hardware in order not to interrupt a running RF transmission.

(The flag SYSST.TDET, which indicates resume from thermal shutdown, works somewhat differently than the other wake-up /resume flags. Therefore it is not reported in [Table 4-3](#) but in [Table 4-4](#), instead.)

Table 4-3 Event sources and indicator flags for all device states

Event	Event indicator flag	Power down	Deep idle	TX low power	Idle state	Run state
		indicator flag behavior / event generates wake-up/resume				
Interval timer elapsed	WUF.ITIM_FLAG	raised / yes	raised / yes	raised / yes	raised / yes	raised / n.a.
External signal at PP2	WUF.EXT_FLAG	raised / yes	raised / yes	raised / no	raised / yes	raised / n.a.
LF carrier detected	WUF.CD_FLAG	raised / yes	raised / yes	raised / no	raised / yes	raised / n.a.
LF sync match	WUF.SYNC_FLAG	raised / yes	raised / yes	raised / no	raised / yes	raised / n.a.
LF pattern 0 match	WUF.PM0_FLAG	raised / yes	raised / yes	raised / no	raised / yes	raised / n.a.
LF pattern 1 match	WUF.PM1_FLAG	raised / yes	raised / yes	raised / no	raised / yes	raised / n.a.
LF end of message	WUF.EOM_FLAG	raised / yes	raised / yes	raised / no	raised / yes	raised / n.a.
LF buffer full	WUF.BF_FLAG	raised / yes	raised / yes	raised / no	raised / yes	raised / n.a.
Timer 0 underflow	REF.RET0	cleared / no	unchanged / no	unchanged / no	raised / yes	raised / n.a.
Timer 1 underflow	REF.RET1	cleared / no	unchanged / no	unchanged / no	raised / yes	raised / n.a.
TX encoder buffer empty	REF.RERFU	cleared / no	unchanged / no	undefined ¹⁾ / no	raised / yes	raised / n.a.
TX encoder shift register empty	REF.RERFF	cleared / no	unchanged / no	undefined ²⁾ / no	raised / yes	raised / n.a.
ADC end of conversion	(reserved)	cleared / no	unchanged / no	raised / no	raised / yes	raised / n.a.
Sampling timer elapsed	REF.RESTF	cleared / no	unchanged / no	unchanged / no	raised / yes	raised / n.a.
Sampling timer power-up	(reserved)	n.a. / no	n.a. / yes	n.a. / no	n.a. / no	n.a. / n.a.

1) Bit RERFU is only used for CPU transmission mode. It has no meaning if the transmission controller ist used.

2) Bit RERFF is only used for CPU transmission mode. It has no meaning if the transmission controller ist used.

Complementary to the flags in [Table 4-3](#) there are four additional flags which indicate from which power state the device woke-up/resumed. Further there is a flag which is set if any unmasked wake-up event was detected and another flag which is set if any unmasked resume event was detected. These six flags and their behavior are listed in [Table 4-4](#). [Figure 4-2](#) shows how all the flags from [Table 4-3](#) and [Table 4-4](#) are connected.

Table 4-4 Additional wake-up/resume indicator flags

Condition for raising the flag	Flag name	Power down	Thermal SD	Deep idle	TX low power	Idle	Run state
Wake-up from power down	SYSST.WUPDWN	raised					
Resume from thermal shutdown	SYSST.TDET		raised				
Resume from deep idle	RESYSCF.REDIDLE			raised			
Resume from TX low power	RESYSCF.RETXLP				raised		
A non-masked wake-up event	DSR0.WUPEND	raised	raised	raised	raised	raised	raised
A non-masked resume event	DSR1.REPEND				raised	raised	raised

Special Features of the SP40T

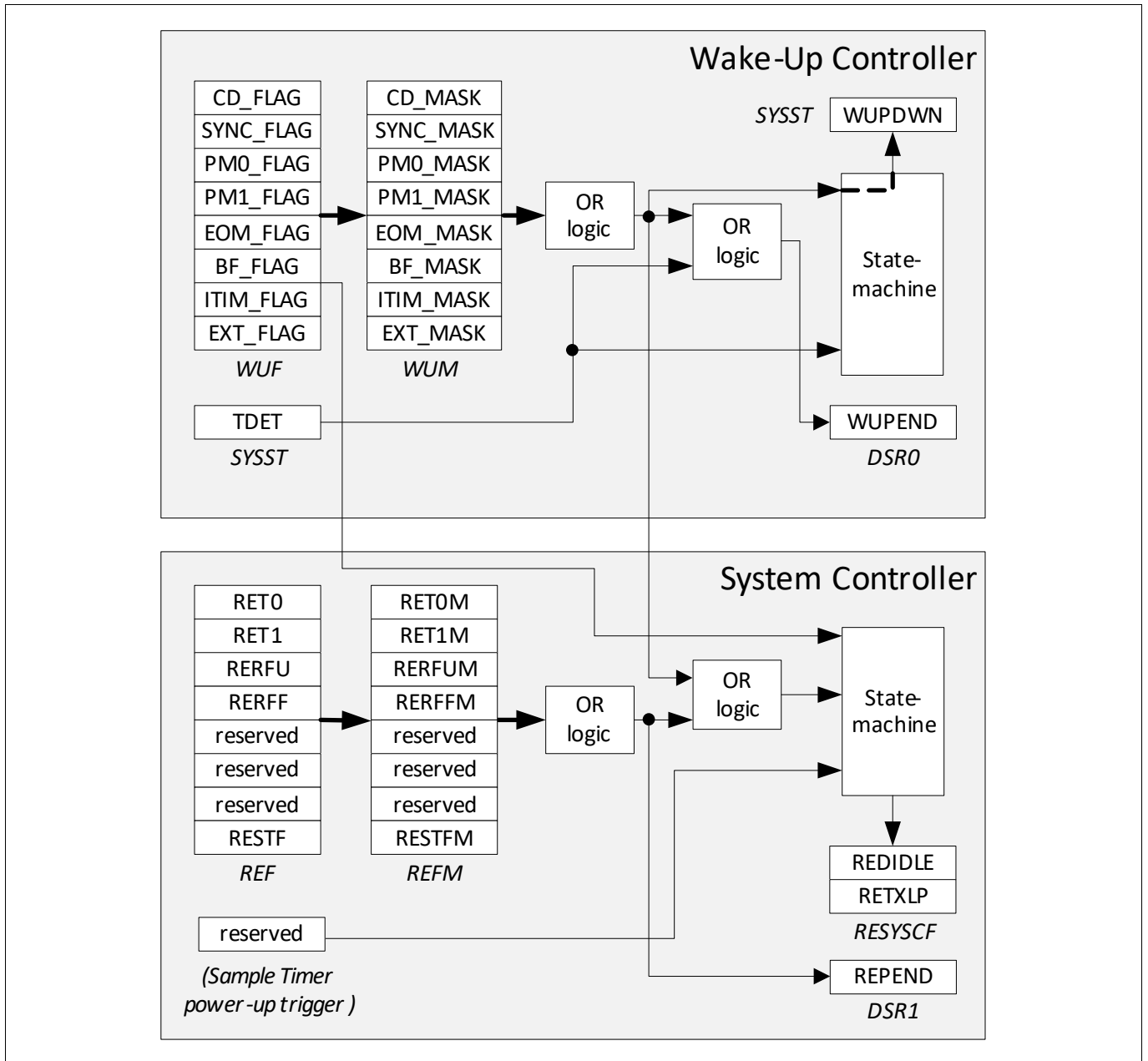

Figure 4-2 Connection between all wake-up/resume related flags

5 Functional Descriptions

5.1 SP40T Block Diagram

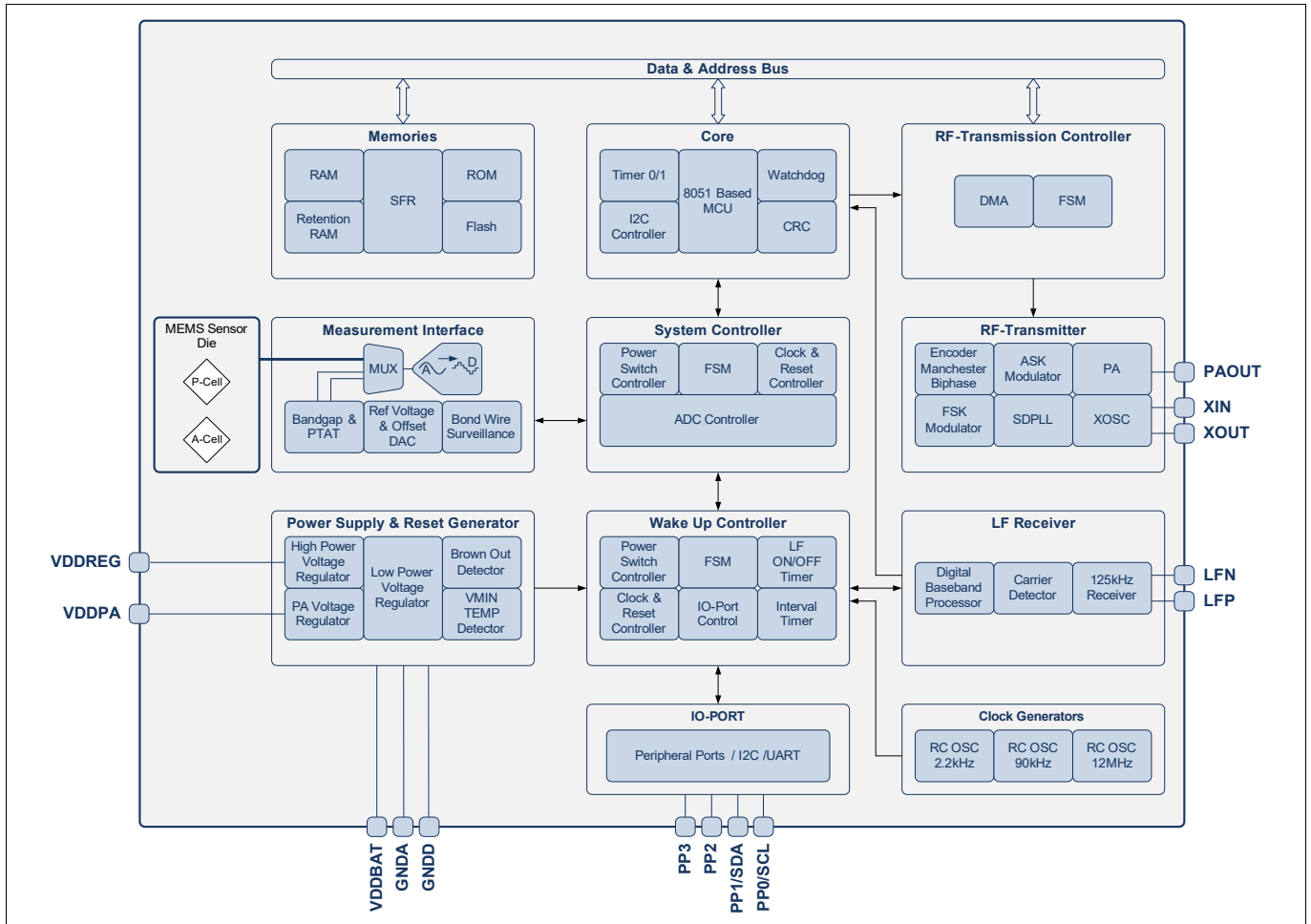

Figure 5-1 SP40T Block Diagram

5.2 Wake-up Controller

In a typical TPMS application the SP40T is in power-down state most of its operating lifetime. In power-down state, which is triggered by calling the firmware function `Lib_Serv_Low_Power(2)`, the device is controlled only by the wake-up controller. The wake-up controller is the block with highest priority in terms of power management. It is always powered and waits for a wake-up event from different sources. For lowest power consumption the wake-up controller is clocked by the 2.2 kHz oscillator. If a wake-up event happens and the event is not masked then the wake-up controller powers on the system controller which takes over device control. The device wakes up in the same mode (normal- or debug- mode) from which power-down was called. Before code execution starts the CPU runs a firmware boot sequence and all registers are initialized with their wake-up values. In case of normal mode the time from wake-up event occurrence until start of application code execution is in the range of several milliseconds (see [Table 2-20](#)). The implemented wake-up sources are:

- Interval timer
- LF-Receiver: carrier detector
- LF-Receiver: sync pattern detector

Functional Descriptions

- LF-Receiver: data pattern matching circuit
- LF-Receiver: data buffer full
- LF-Receiver: end of message
- General purpose I/O PP2
- Temperature detector when device is in thermal shutdown

The second main function of the wake-up controller is reset handling. The reset signals themselves are generated in the block “power supply & reset generator”. A system-reset may be triggered by:

- Brown out (internal regulated voltage drops below a certain threshold)
- Power on
- Under voltage (battery voltage below a certain threshold, see [Table 2-10](#))
- Software
- Watchdog
- Flash Error (detected via error correction code, ECC)

Apart from the flash error all other system-reset events are not maskable. The register SYSST indicates the reset source after restart of the device and can be read in application code. After reset release a firmware boot sequence is executed, the registers are initiated with their reset values, and an I²C handler is called. The handler waits a certain time (see “mode selection time”, [Table 2-20](#)) for a valid I²C mode selection command [2]. If no valid I²C signal is received the device starts application code execution after mode selection time elapses.

Although **thermal shutdown state** is not identical with power-down state, thermal shutdown release event behaves like a wake-up and all registers are initiated with their wake-up values.

The flag WUPEND allows to distinguish if a wake-up or another restart, i.e. reset or resume, occurred. In case of thermal shutdown release WUPEND indicates the wake-up, too.

For identification each wake-up source has its own flag in register WUF (only flag TDET is located in SYSST.) Several flags may be set in WUF if more than one wake-up event occur before reading WUF. Since WUF is cleared on read, it is recommended not to read single bits but copy WUF into RAM before analyzing it. The flags in the corresponding WUM register are used for masking individual wake-up sources. Although there is a masking flag for the interval-timer this flag has no effect: the interval-timer wake-up is not maskable for fail-safe reasons. Note that if masking a wake-up event in the WUM register the corresponding wake-up is not triggered when the event occurs, but the corresponding flag in the WUF register is always set, independent of the WUM setting and independent on device state (low power, run state etc.). This way it is possible to check the WUF for events that did not trigger a wake-up in order to process these events at a later point in time.

Furthermore the wake-up controller comprises the LF ON-OFF timer that allows operating the LF-receiver with a configurable duty cycle for power saving reasons. Details see [Chapter 5.11](#).

Important registers associated with the wake-up controller are:

- DSR0 (bit WUPEND. This bit indicates a pending wake-up event)
- SYSST (indicates the system reset source)
- RMASK (Reset mask register)
- WUF (indicates the wake-up source)
- WUM (for masking certain wake-up sources)
- CFG0 (bit SRESET for triggering software reset)

5.2.1 Interval Timer

The purpose of the interval timer is to periodically wake-up the device from power down. The timer is active in any low power state and is clocked by the 2.2kHz oscillator. The interval timer is counting down, a wake-up event

Functional Descriptions

is triggered upon timer underflow. Although there is a masking bit available in WUM register for the interval timer, the wake-up event cannot be masked in normal mode. Especially when using the TX-low-power or deep-idle state it must be made sure by proper timing setting that the interval timer does not interrupt the telegram transmission or the data acquisition.

The interval timer is separated into a 12 bit pre-counter (SFRs IT0 and IT1) and a 12 bit post-counter (SFRs IT2 and IT3). For calibrating the pre-counter a firmware function is provided. The post-counter is set by directly writing to IT2/IT3. This concept allows for quick changing of the timer interval by just changing IT2/3 without running the calibration routine. Note that writing to IT0/1/2/3 is setting the pre- and post-counter preload value, reading IT0/1/2/3 provides the current counter reading. The timer is automatically reloaded after underflow.

In thermal shutdown the interval timer is used for periodically checking the temperature detector.

The associated registers are:

- IT0, IT1: interval timer pre-counter (also referred to as tick counter)
- IT2, IT3: interval timer post-counter (also referred to as period counter)
- CFG0.ITINIT: Setting this bit initializes the interval timer with the preload value

5.2.2 LF ON-OFF Timer

The ON-OFF timer is used for switching on and off the LF receiver with a low duty cycle in order to save energy. Consequently the timer supports long OFF-times of up to 5.7 sec and shorter ON-times of maximal 0.36 sec. Note that the LF reception is inhibited 3.9 ms by design after being switched on because the LF receiver needs some time to settle, i.e. the effective On-time is accordingly shorter.

Here are the minimum ON-times for some use cases:

- Carrier Detection for LF-CW signal: minimum ON-time = 3.9 ms + 0.1 ms = 4 ms
- Carrier detection for pulsed LF carrier: minimum ON-time = 3.9 ms + 4.75 ms = 8.7ms
- Data reception mode for periodic repetition of LF-telegram: minimum ON-time = 3.9 ms + period time

The user does not need to directly access the ON-OFF timer registers since the firmware function Lib_Serv_OnOff_Timer_Calib() can be used for configuration. Setting bits ENLFRX and ENOOTIM activates the ON-OFF timer. The current count value of the ON-OFF timer cannot be read by software.

Associated registers:

- LFRXC, bits ENTOOM and ENLFRX

5.2.3 LF receiver wake-up/resume events

All wake-up events generated by the LF receiver are maskable. The events are:

- Carrier detected
- Sync pattern detected
- Wake-up pattern match
- Data buffer full detected
- End of message

Refer to [Chapter 5.11](#) for more details.

5.2.4 General purpose I/O PP2 wake-up/resume event

I/O Port PP2 allows maskable wake-up from an external source. In order to use this wake-up source, PP2 needs to be configured as input (Flag PPD2=1), the corresponding pull resistor must be enabled (Flag PPO2 = 1) and the corresponding wake-up must be enabled (Flag EXT_MASK = 0).

Functional Descriptions

The flag PPS2 is used to define whether the wake-up is triggered on high or low level. If PPS2 = 1 wake-up is triggered on high level at PP2 pin.

5.2.5 Power-on and under-voltage reset

Figure 5-2 shows the device behavior depending on voltage at VDDBAT pin. If the voltage falls below a certain threshold V_{UVRA} a system-reset is triggered. The device stays in reset until the voltage at VDDBAT pin exceeds the reset release threshold V_{THR} . After reset release the device initialization is started which takes a certain time, t_{ini} . After the initialization phase the operation mode of the device can be selected by sending an I²C command. The mode selection is only possible during the time interval t_{MS} . If t_{MS} elapses without reception of any valid I²C command, the device goes into normal mode. If a valid I²C command is received during t_{MS} the device starts up in the corresponding mode right after command reception. **Table 5-1** shows the behavior of the device during t_{MS} depending on received I²C command.

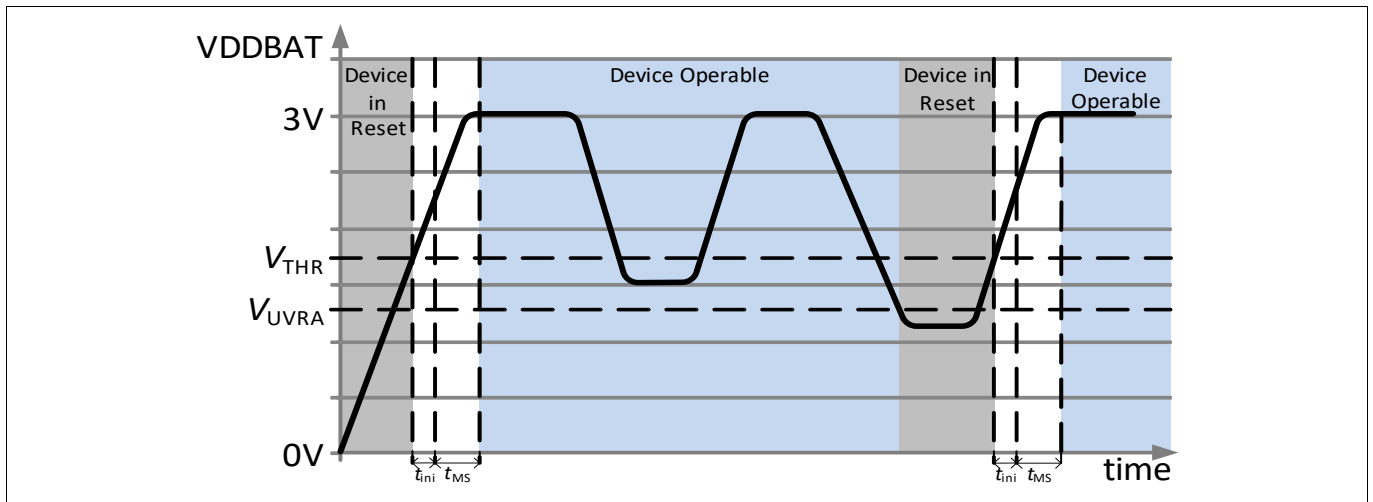

Figure 5-2 Power-on and under-voltage behavior

Table 5-1 SP40T behavior during mode selection phase

I ² C Command	Device behavior
None	Start with normal mode after t_{MS} elapsed
Wrong I ² C address	Start with normal mode after t_{MS} elapsed
Invalid mode selection command	Start with normal mode after t_{MS} elapsed
Valid mode selection command	Start with selected mode immediately after command reception

5.2.6 Software reset, watchdog reset and flash error reset

After a reset triggered by software, watchdog or flash-error the device runs through the reset boot sequence and the mode selection phase.

The software reset can be triggered by setting the bit SRESET (located in register CFG0) in application code.

A flash-error reset occurs if the flash error correction logic (ECC) detects a non-correctable double bit error (ECC2) when reading a byte from flash.

Register SYSST is used to identify the reset source after a system reset.

Functional Descriptions

5.2.7 Thermal Shutdown

Thermal shutdown is triggered by calling the firmware function `Lib_Serv_Thermal_Shutdown()` in application code. This firmware function brings the SP40T into shutdown if the temperature is either above the hot temperature threshold T_{HOT_TH} or below the cold temperature threshold T_{COLD_TH} by using a dedicated temperature detector. Once in thermal shutdown the device is only released if the on-chip temperature detector indicates a temperature below the hot release temperature T_{HOT_RE} or above the cold release temperature T_{COLD_RE} . In order to save energy during thermal shutdown the temperature detector is not powered continuously but switched on periodically by the interval-timer. The period is defined by function parameter when calling `Lib_Serv_Thermal_Shutdown()`.

After release from thermal shutdown a wake-up is performed and flag WUPEND is set. However, in this case the wake-up source is not indicated by WUF register, but by bit SYSST.TDET.

5.3 System Controller

Main function of the system controller is power management after device wake-up from power-down or device resume from idle, deep idle state or TX-low-power state. Unlike the wake-up controller most other circuits can be disconnected from power individually. Depending on the device state the system controller connects the required blocks to the power domain. Here the device states are listed, ordered by current consumption, starting with the state with highest current consumption:

- TX low power state during RF transmission
- Run state
- Idle state (run state with CPU disconnected from system clock)
- TX low power state during interframe time
- Deep idle state
- Power-down state (optional with LF receiver enabled)¹⁾

Important registers associated with the system controller are:

- REF (maskable resume event flag register)
- RESYSCF (indicates resume from deep-idle and TX-low-power)
- REFM (resume event mask register)
- DSR1 (bit REPEND. This bit indicates a pending resume event)
- CLKCFG (field DIVIC for selecting an optional system clock division factor)

1) The power-down state is controlled by the wake-up controller and not by the system controller

Functional Descriptions

5.3.1 Sampling Timer

In certain applications periodic acceleration measurements must be carried out over a longer period of time. There are two major requirements for this application: low power consumption and exact keeping of time (sampling interval) between two acceleration measurements. In order to meet these requirements a timer is needed which runs in a device state with very low power consumption, namely the deep idle state. Unlike in power-down, in deep idle the 90 kHz oscillator is running for providing the needed timing accuracy.

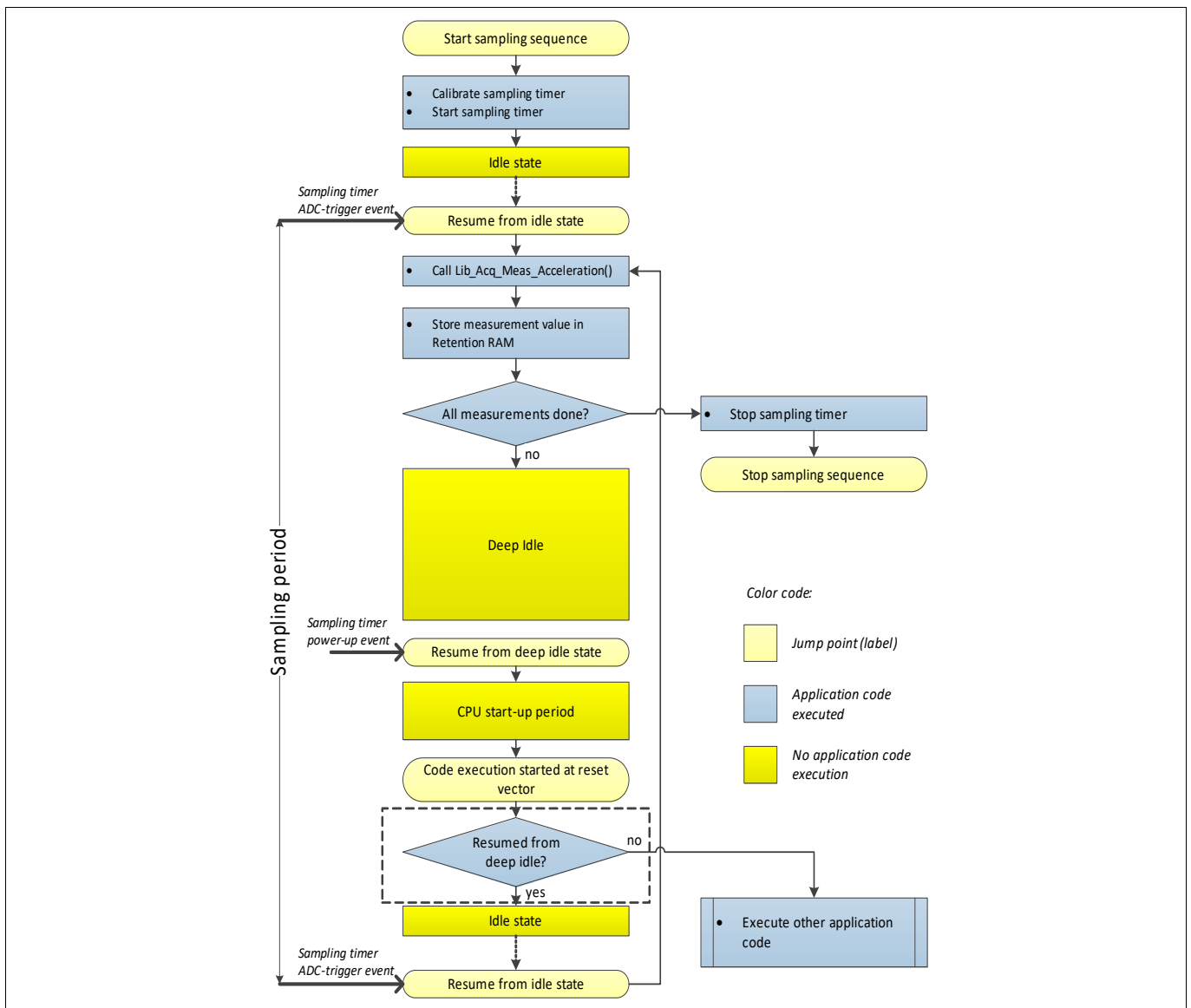

Figure 5-3 Sampling timer application flow

In order to use the sampling timer it needs to be calibrated and started in application code (see flow diagram in [Figure 5-3](#)). Subsequently idle state must be entered immediately because resume from idle (ADC triggered event) occurs only a few 10µs after starting the timer. After resume from idle, when application code execution continues, the acceleration acquisition function should be called at first. Thereafter additional application code can be carried out in order to store measurement values in retention RAM.

If more samples must be acquired, application code then enters deep idle state in order to save energy; otherwise the sampling timer can be stopped and the sequence is terminated. The sampling timer resumes the device from deep idle state by power-up event. The CPU is re-started and code execution starts from the reset vector. Here the application code must decide if the device was restarted from deep idle state or not. If yes, idle state is

Functional Descriptions

entered and the next sample is measured when idle state ends. If not, the CPU was restarted due to another event and the corresponding application code must be executed.

The implementation of the two trigger events allows exact keeping of sampling period because resuming from idle state occurs without time delay and the idle state period buffers possible variations of the start-up time. In order to save energy the idle period should be kept as short as possible.

There is no need to configure the sampling timer registers directly because the library function `Lib_Serv_Sample_Timer_Calib()` is available for this purpose [1]. The execution time of the application code marked by the dashed rectangle in **Figure 5-3** is an input parameter for this function. The function calculates the point of time for resume from deep idle by considering the code run time and the power-up time (the power-up time is composed of hardware start-up time and firmw are boot sequence, for the exact value see **Table 2-20**). This way the idle period is kept no longer than necessary because power consumption in idle state is higher than in deep idle state.

Note that the deep idle state can be terminated by LF-receiver events, interval-timer or PP2 event. Hence it must be made sure in application that sampling phase is not affected by one of these event sources, e.g. by masking the corresponding flags.

Associated registers:

- STIMCFG0 (sampling timer low byte)
- STIMCFG1 (bit EN for enabling sampling timer and sampling timer high bits)
- STIMCFG2 (power up period configuration)

5.4 Clock Generators

The SP40T comprises three on-chip RC oscillators in order to fulfill the extremely different requirements in terms of power consumption and cycle time for different operating states. A 2.2 kHz oscillator is operated in power-down for lowest power consumption. A 90 kHz oscillator is implemented for clocking the system controller, the interframe timer, the sampling timer, and the digital part of the LF receiver. Finally a 12 MHz oscillator is used for the CPU. This clock may be divided (controlled by bit field DIVIC) and is called system clock. The 90 kHz and 12 MHz clock sources are switched on by the wake-up controller and the system controller, respectively, and only if needed. The 90 kHz and 12 MHz oscillators are trimmed in production.

For RF transmission and calibration purposes a crystal oscillator is implemented as well. Details about the implementation of the crystal oscillator are described in **Chapter 5.9.7**.

Figure 5-4 shows a fundamental clock distribution diagram, i.e. which clock source is used for which digital block. The white triangles (gates) indicate for which blocks the clock can be gated in order to save energy. For most blocks the gating is done automatically. In some cases gating can be controlled by application code. In this case the corresponding control bit is drawn next to the gate.

Most SFRs are always clocked by system clock if the CPU is running. But there are some exceptions which are depicted in **Figure 5-4**, namely registers RFD, RFS and RFENC. Clock distribution to these registers is controlled by internal control bits TXMASTER and RFENC. These control bits are configured by firmware function `Lib_Serv_Config_RF_Transmission`. The bits are mentioned for information only.

Functional Descriptions

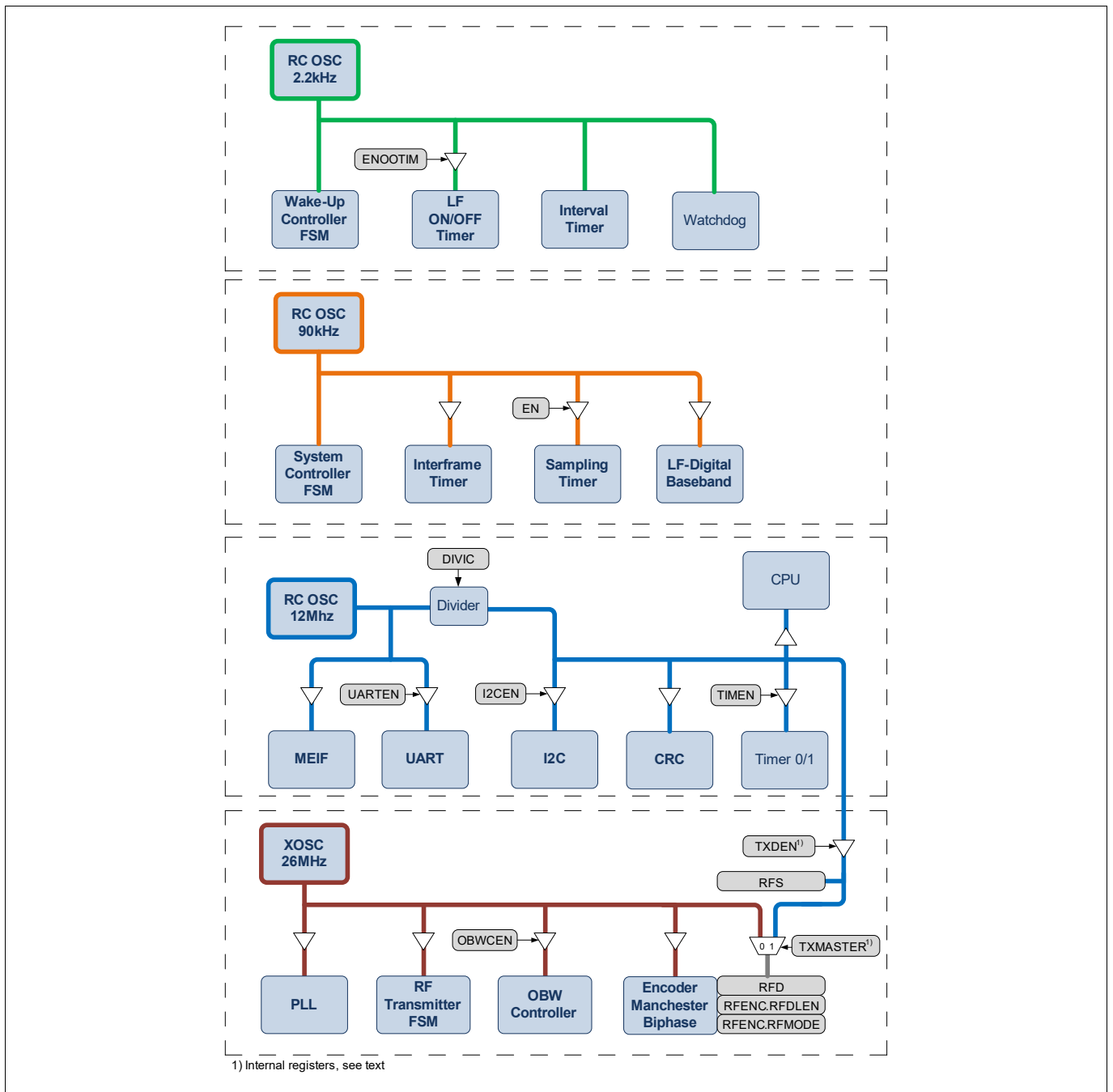

Figure 5-4 Clock distribution diagram

5.5 Core

The Core comprises a 8051 based MCU and the following peripherals:

- Timer Module
- Watchdog
- Hardware CRC
- I²C Controller
- UART interface

Functional Descriptions

5.5.1 Timer Module

The timer module consists of six registers TCON, TMOD, TL0, TH0, TL1 and TH1. The timer module enable bit TIMEN is located in register CFG2. Those firmware routines that are using timers disable the timer module prior to returning to application code. Therefore generally TIMEN should be set before timer module is configured and started in application code. TIMEM should be cleared if the timers are no longer used in order to reduce power consumption.

The timer module can be configured to 8 different modes (mode 0 to 7) by setting the three TM bits accordingly. The modes differ in timer length (8 bit or 16 bit) and timer behavior (timer stops on underflow or timer reloads and restarts on underflow). The four registers are either used as down counter or for holding the reload value. In principle following timer modes are supported:

- Two 16 bit timers without reload (single run)
- Two 8 bit timers with reload
- One 16 bit timer with reload
- One 16 bit timer without reload plus one 8 bit with reload
- Three 8 bit timers, one with reload.

Table 5-2 and **Table 5-3** show in detail how the registers are configured in each mode. Timer mode 7 is not reported because this mode is not available in application code, but is used by firmware for calibration purposes.

The timer module does not allow CPU interrupt. Instead of that the timer underflow bits need to be polled in application code. The timer module can be clocked from different clock sources thus providing a wide range of timing cycles and allowing for calibrating internal clock sources with the crystal oscillator. The clock source for timer 0/1 depends on the clock source select bits T0CLK and T1CLK and on the timer module crystal clock enable bit TCLKM. Following clock sources are selectable:

- 12 MHz RC oscillator divided by 1, 8, 32, 128 or 512 (independent from DIVIC)
- 4.4 kHz, derived from 2.2 kHz low power RC oscillator
- Timer 0 only: clocked by timer 1 underflow
- Timer 1 only: rising edge at PP2
- Crystal clock divided by 6
- Timer 0 only: Crystal clock divided by 512
- Timer 0 only: 90 kHz RC divided by 8

Note: the timer clock source must not be mixed up with the system clock used for loading the timer registers. The timer module system clock is always 12MHz with a division factor defined by DIVIC (see **Figure 5-4**).

Timer configured without reload

If a timer is configured to work without reload it stops on underflow and must be restarted by software. Prior to starting the timer it can be loaded with an initial value. When started by setting the timer run bit the timer counts down from the initial value to zero. When the timer has reached zero the underflow event is triggered on the next clock cycle. The timer run bit is cleared on underflow; the timer full flag is set on underflow.

Timer configured with reload

If a timer is configured to operate with reload it is automatically reloaded from a reload register and restarted on underflow. Prior to starting the timer it can be loaded with an initial value different from the reload value. A timer full flag indicates underflow and must be cleared by software. The timer is started by setting a timer run bit and stopped by clearing this bit.

Functional Descriptions

Table 5-2 Timer Modes 0 to 2

Register or Flag Name	Mode 0	Mode 1	Mode 2
TL0	timer 0: 16 bit timer with reload	timer 0: 16 bit timer without reload	timer 0: 8 bit timer with reload
TH0			timer 0 reload value
TL1	timer 0 reload value	timer 1: 8 bit timer with reload	timer 1: 8 bit timer with reload
TH1		timer 1 reload value	timer 1 reload value
T0RUN	timer 0 run bit	timer 0 run bit	timer 0 run bit
T0FULL	timer 0 full bit	timer 0 full bit	timer 0 full bit
T1RUN	not used	timer 1 run bit	timer 1 run bit
T1FULL	not used	timer 1 full bit	timer 1 full bit

Table 5-3 Timer Modes 3 to 6

Mode 3	Mode 4	Mode 5	Mode 6
timer 0.1: 8 bit timer w/o reload	timer 1 reload value	timer 0: 8 bit timer with reload	timer 0: 16 bit timer without reload
timer 0.2: 8 bit timer w/o reload		timer 0 reload value	
timer 1: 8 bit timer with reload	timer 1: 16 bit timer with reload	timer 1: 16 bit timer without reload	timer 1: 16 bit timer without reload
timer 1 reload value			
timer 0.1 run bit	not used	timer 0 run bit	timer 0 run bit
timer 0.1 full flag	not used	timer 0 full flag	timer 0 full flag
timer 0.2 run bit	timer 1 run bit	timer 1 run bit	timer 1 run bit
timer 0.2 full flag	timer 1 full flag	timer 1 full flag	timer 1 full flag

Note that in timer modes 1, 2 and 3 timer 1 is used as Baud-rate generator for RF transmission. Hence, for RF transmission, the timer module must be configured to one of the three mentioned modes.

With timer module associated registers:

- TCON
- TH0
- TH1
- TL0
- TL1
- TMOD
- CFG2 (bit TIMEN)

5.5.2 Watchdog

The watchdog timer is clocked by the 2.2 kHz oscillator. It is active in all run states and in idle state and cannot be disabled. The nominal time-out occurs after 2048/2.2 kHz ~ 1sec. In order to avoid a watchdog reset event the watchdog timer must be reset in application code by setting the flag WDRES periodically. In all low power states, except from idle state, the watchdog timer is disabled and has no effect. On wake-up or resume from a low power state, except from idle state, the watchdog is reset automatically.

Functional Descriptions

In program- and debug-mode where the device is controlled by I²C the firmware I²C handler resets the watchdog. Since in idle state no application code can be executed, idle state must not take longer than the watchdog time-out period.

Associated register:

- CFG2 (bit WDRES for resetting watchdog)

5.5.3 Hardware CRC

The SP40T comes with a hardware CRC module. This module calculates a 16 bit CRC value of an arbitrary sequence of bytes in accordance with the CRC-CCITT (CRC16) standard, i.e. using the polynomial 0x1021. As start value for CRC calculation 0xFFFF should be used, however the CRC module may be initialized with other start values as well.

The CRC module is used by the firmware I²C handler which checks the CRC value of incoming I²C commands and calculates the CRC value for outgoing telegrams.

CRC of a sequence of data bytes

The CRC module can be used in application code as well. For this end the start value 0xFF must be loaded into the two CRC registers CRC1 and CRC0, respectively. Then the data bytes are written subsequently into the CRC data register CRCD. After processing all data bytes registers CRC1 and CRC0 hold the result.

The flag CRCVALID is set automatically if the result is zero, i.e. CRC1 and CRC0 are both zero. This flag can be used for simply checking the CRC of incoming telegrams by initializing CRC1 and CRC0 with 0xFF, then subsequently writing the data bytes and the two CRC bytes of the telegram to the CRC data register. If there is no bit error in the telegram the result is zero and CRCVALID is set.

CRC of a serial bit-stream

The CRC hardware can also be used for calculation of the CRC of a serial bit-stream. The bit CRCSD is the input for the serial bit-stream. The bit CRCSS is the corresponding strobe signal.

As for byte processing the result registers CRC1 and CRC0 must be initialized with 0xFF, respectively. After writing a bit into CRCSD, bit CRCSS has to be set and reset by software. Then the next bit is written into CRCSD and so on.

If a bit-stream is longer than 8 bit, serial and byte-wise CRC encoding can be mixed. As long as more than 8 bits are left, data can be written byte-wise into the CRC data register. Finally, the residual bits are processed using CRCSD and CRCSS.

With hardware CRC associated registers:

- CRCC (bits CRCSD, CRCSS, CRCVALID)
- CRCD
- CRC0
- CRC1

5.5.4 I²C Controller

The SP40T features a slave hardware I²C interface with the fixed device address 0x6C. When the I²C is activated, pin PP0 is configured as input and serves as clock line (SCL). Pin PP1 is initialized as input, too, and serves as data line (SDA). Both lines need a pull-up resistor, either an external resistor or by activating the internal pull-up resistors. The active device transmits data by pulling the data line low.

In program- and debug- mode the I²C interface is managed by a firmware I²C handler. Only certain I²C commands are available in these modes, no application code can be executed. The internal pull-up resistors are enabled by the I²C handler.

Functional Descriptions

In power-down state the I²C is disabled and PP0 and PP1 stay in the state configured by application code. In program- or debug- mode is not possible to switch the SP40T into power-down by I²C command.

In normal mode the I²C (if needed) must be managed by application code. For activating the I²C interface the bit I²CEN must be set. If internal pull-up resistors shall be used the bits PPI0 and PPO0 must be set in order to enable the pull-up resistors of pin PP0. Bits PPI1 and PPO1 must be set in order to enable the pull-up resistor of pin PP1. The port direction register is managed automatically by the I²C interface.

Receiving data from master in normal mode

Once activated, the I²C register waits for a start condition. The following 8 bits are interpreted as device address and compared to 0x6C. If the received address matches, acknowledge (ACK) is generated, i.e. the data line is pulled down on the 9th clock pulse. The address match is indicated by the flag AM. Polling this flag may be used to branch into a data reception subroutine.

The next 8 bits are interpreted as data bits and are also acknowledged by pulling the data line low. The complete reception of a data byte is indicated by the flag I²C_RBF. The application code needs to poll this flag and fetch the data from the register I²CD. I²C_RBF is cleared automatically when reading I²CD. This procedure is repeated for incoming data bytes until a stop condition is received. The flag I²C_S indicates that a stop condition has been received.

Transmitting data from SP40T to master in normal mode

The LSB of the device address serves as a read-write indicator. Thus, in order to put the SP40T in data transmission mode, the master must send the device address 0x6D. The flag I²C_RNW indicates to the software that the read-write indicator bit is set and that data can be transmitted from SP40T to the master. The software can poll this flag for branching into a data transmission subroutine. In this subroutine data bytes can be written into the I²CD register when the flag I²C_TBF does not indicate a full transmit buffer. This procedure can be repeated for outgoing data bytes until a stop condition is received.

The I²C interface also provides a data overflow flag. This flag is set if new data is received before reading I²CD or data is written to I²CD before transferring the previous data byte to the I²C shift register.

The principle I²C data transfer is shown in **Figure 5-5**. The shaded areas indicate when SDA line is controlled by the master, the non-shaded areas when the SDA line is controlled by the sensor.

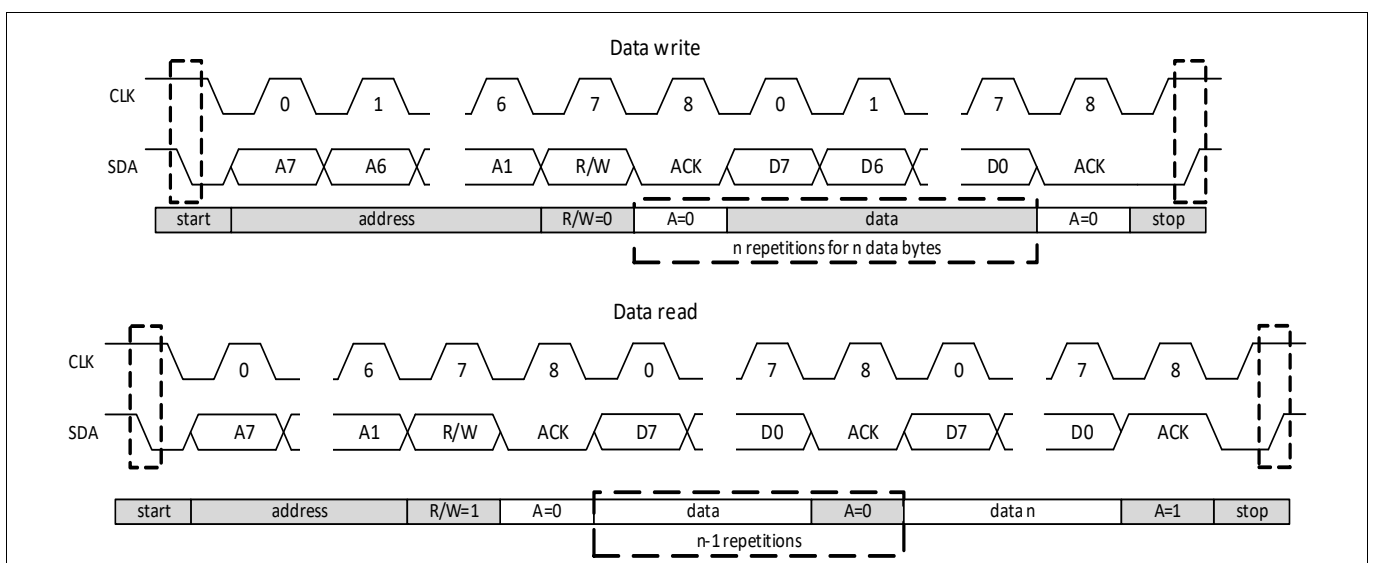

Figure 5-5 Data transfer on the I²C bus

Functional Descriptions

With the I²C controller associated register:

- CFG2 (bits I²CEN and I²CGCEN)
- I²CD
- I²CS

5.5.5 UART Interface

The SP40T has a hardware UART interface. If enabled, pin PP2 serves as UART-RX and PP3 as UART-TX. (Note that the port direction, i.e. PP2 as input and PP3 as output, must be configured in application code.) The UART port is half-duplex, i.e. data transmission and reception must not occur simultaneously. The port is receive buffered, i.e. a second byte can be received before the previous byte is read from the receive register.

Although there are separate shift registers for reception and transmission, both registers are accessed via the same special function register UASBUF. Reading UASBUF accesses the receive buffer and writing to UASBUF accesses the transmission shift register.

The UART interface supports an 8 bit data mode with 1 stop bit which is added automatically. The transmission is activated by a write operation to UASBUF. End of byte transmission is indicated by flag TI. This flag must be cleared by software. The receive flag RI indicates that a byte can be read from the receive buffer. This flag must be cleared by software, too.

The UART interface has a Baud-rate generator which is clocked by the system clock, i.e. by the 12 MHz oscillator. The Baud-rate generator consists of a prescaler, a timer and a fractional divider. The prescaler divides system clock, the division factor is selected by a three bit value BRPRE. The timer is counting downwards; it is loaded with the value BR_VALUE on underflow. The fractional divider provides an output clock that is given by the input clock divided by 256 and multiplied by the 8 bit value UASFDSTEP.

Table 5-4 shows possible Baud rates and the corresponding register settings.

Table 5-4 UART Baud-rate selection

Baud-rate	BRPRE	BR_VALUE	UASFDSTEP
19200	000 _B	35	236
28800	000 _B	23	236
38400	000 _B	17	236
56000	000 _B	8	172
57600	001 _B	5	236
115200	000 _B	5	236

Following registers are associated with the UART interface:

- UASCFG (bits RCLKEN and TCLKEN for enabling the receive and transmit clock)
- UASCON (indicator flags RI and TI and receiver enable bit REN)
- UASBUF (for accessing receive buffer and transmit shift register)
- UASBCON (containing the Baud-rate generator enable bit R and the prescaler control bits BRPRE)
- UASBG (containing the Baud-rate timer reload value BR_VALUE)
- UASFDCON (with the fractional divider enabling bit FDEN)
- UASFDSTEP (containing the fractional divider configuration value UASFDSTEP)
- UASFDRES (serial port fractional divider result register)
- CFG2 (bit UARTEN)

Functional Descriptions

5.6 Memories

The 8051 based microcontroller core is able to address a 64kB wide range of code memory. In the SP40T this address range is used for the following types of memory:

- 40 kB ROM for firmware
- 1 kB Flash memory for factory configuration data (IFX configuration sector)
- 12 kB Flash memory for application code (user code sector)
- 2 kB Flash for extended code (extended code sector)
- 256 byte Flash memory for user configuration data (user configuration sector)
- 5x32 byte Retention RAM

Figure 5-6 shows the corresponding memory mapping. The content of the ROM sector and IFX configuration sector cannot be changed. Both sectors are protected against reading by lock-byte 1, which is factory set.

Each flash byte is secured by a five bit error correction code (ECC). The ECC bits are generated automatically when the flash byte is programmed. When a flash byte is read, the error correction unit can correct all single bit errors and detect all double bit errors.

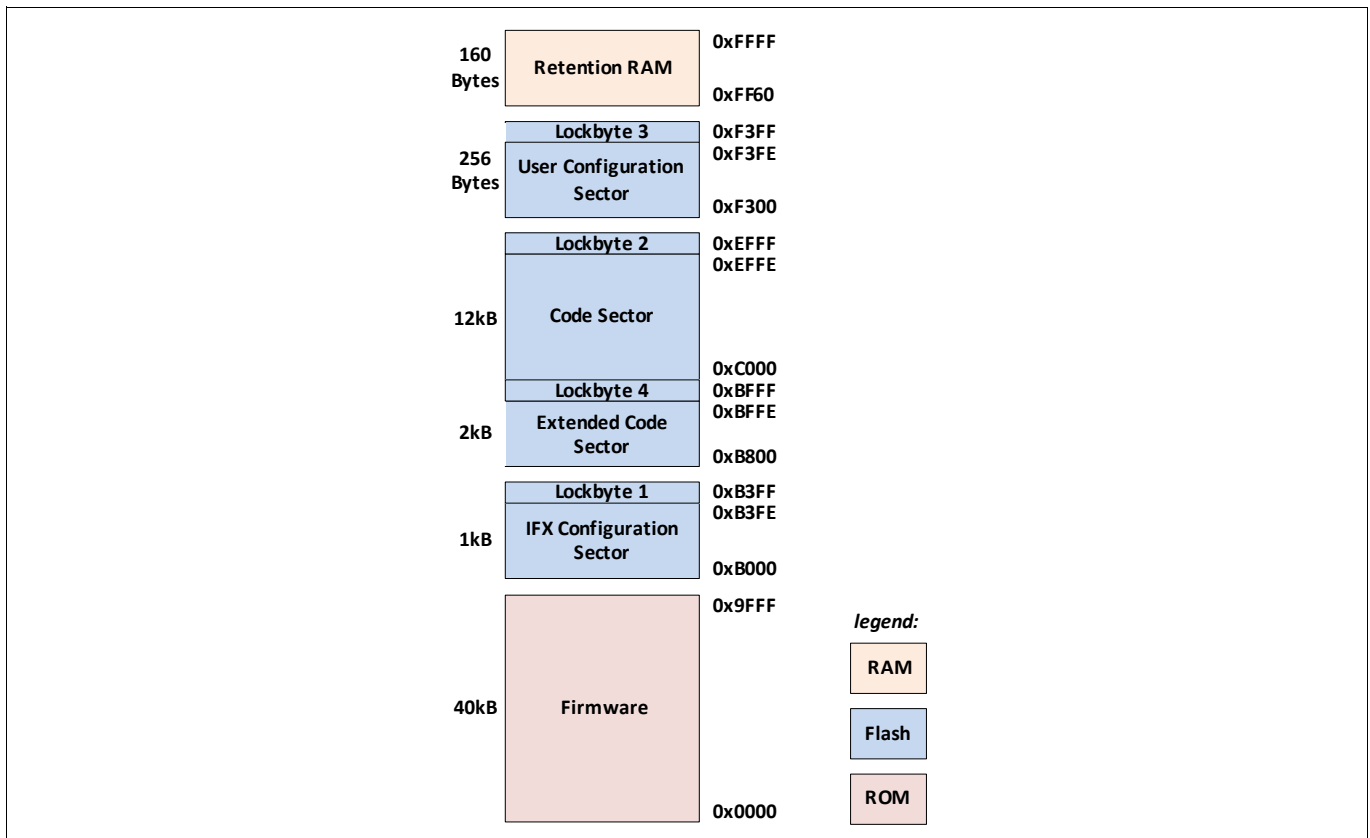

Figure 5-6 Code memory organization

5.6.1 Extended code sector

The extended code sector is intended for a bootloader routine. This routine may receive data from the LF receiver and re-program the user code sector. For this purpose the functions Lib_Fl_Erase_Code_Sector and Lib_Fl_Write_Line can be called from code located in the extended code sector in order to erase and re-program the user code sector. The extended code sector is separately protected by a lock-byte.

Functional Descriptions

5.6.2 Lock-byte concept overview

At the end of each flash sector there is a lock-byte, which may be enabled by the user in order to protect the sector against overwriting and reading. In order to activate a lock-byte it must be written with the value 0x69. However, for security reasons, other lock-byte values with a Hamming distance from 0x69 of up to 3 are also considered as valid. The lock-bytes are not independent from each other. There is a certain priority for each lock-byte:

- Priority 1: lock-byte 4 (for extended code sector)
- Priority 2: lock-byte 2 (for user code sector)
- Priority 3: lock-byte 3 (for user configuration sector)

Note that an enabled lock-byte with a lower priority only becomes effective if all higher prioritized lock-bytes are already enabled. Furthermore enabling lock-bytes only becomes effective after device reset.

Figure 5-7 shows the possible lock-byte settings and their effect on the flash sectors for program mode and normal mode. Debug-mode cannot be used if lock-byte 2 is active.

Protected Flash Sectors	LB 2	LB 3	LB 4	Normal Mode			Programming Mode		
				Extended Code	User Code	User Config	Extended Code	User Code	User Config
none	0x00	0x00	0x00	Read: yes* Write: no Erase: no	Read: yes* Write: yes Erase: yes	Read: yes* Write: yes Erase: yes	Read: yes Write: yes Erase: yes	Read: yes Write: yes Erase: yes	Read: yes Write: yes Erase: yes
Extended Code	0x00	0x00	0x69	Read: yes* Write: no Erase: no	Read: yes* Write: yes Erase: yes	Read: yes* Write: yes Erase: yes	Read: no Write: no	Read: yes Write: yes	Read: yes Write: yes
Ext. Code + User Code	0x69	0x00	0x69	Read: yes* Write: no Erase: no	Read: yes* Write: no Erase: yes	Read: yes* Write: yes Erase: yes	Read: no Write: no	Read: no Write: no	Read: yes Write: yes
Ext. Code + User Code + User Config	0x69	0x69	0x69	Read: yes* Write: no Erase: no	Read: yes* Write: no Erase: yes	Read: yes* Write: no Erase: yes	Read: no Write: no	Read: no Write: no	Read: no Write: no
							Erase all sectors at once: yes		
							Erase all sectors at once: yes		
							Erase all sectors at once: yes		

*no firmware support, read flash by using CPU commands MOVX or MOVC

Figure 5-7 Lock-byte settings and effects in program- and normal- mode

5.6.3 Flash programming

For programming the user code sector or the user configuration sector **in program mode** there are two I²C commands available. The command Erase-Sectors for deleting the sectors as a whole and the command Flash-Write-Line for programming a 32 byte long flash line. For enabling the lock-bytes LB2 or LB3 the value of the lock-byte location must be defined as 0x69 when writing to the corresponding line with the Flash-Write-Line command. If a lock-byte shall remain disabled, its value must be defined as 0x00. The I²C command Set-User-Config-Sector-Lock also allows enabling LB3 after writing the last line. There is no such I²C command for LB2.

For programming the user configuration sector **in normal mode**, i.e. during runtime, the firmware functions Lib_FL_Erase_User_Config_Sector, Lib_FL_Write_Line and Lib_FL_Change_UCS_Line() are available. For setting the user configuration lock-byte (LB 3) the value of the last byte must be defined as 0x69 when writing or changing the last line of the user configuration sector.

Note: IFX recommends shutting off the flash using I²C command PM Flash Shut Down before disconnecting the device from supply voltage.

Functional Descriptions

5.6.4 Retention RAM

In order to save information when the device is in a low power state or in thermal shutdown there are 5 blocks of 32 bytes of retention RAM available. Via five configuration bits (RETMEM) each retention RAM block can be enabled individually for staying always powered. The retention RAM is mapped to the external RAM address space of the 8051 controller. Hence, in a C environment, the directive XDATA must be used to define a variable located in retention RAM area.

The retention RAM has random values after power-on, i.e. after being connected to a battery. Enabled retention RAM will keep its values in all device states as long as the device is connected to the battery.

Associated registers:

- MEMCFG, bits RETMEM

5.6.5 Data RAM and SFRs

The SP40T microcontroller core has a 256 Byte address space for data RAM that can be used in application code. The address space 0x80 to 0xFF of the upper 128 Bytes of data RAM is shared with the Special Function Register (SFR) bank. The two register banks are selected via addressing method. If direct addressing is used a SFR is selected, if indirect addressing is used data RAM is selected. The RAM in the lower addressing range can be accessed either by direct or indirect addressing. This is illustrated in Figure 5-8.

The SFR bank consists of three pages. There are two control bits, PAGING0 and PAGING1, for switching between the three pages. These bits are located in the special function register CPUSYS which is mapped to all pages.

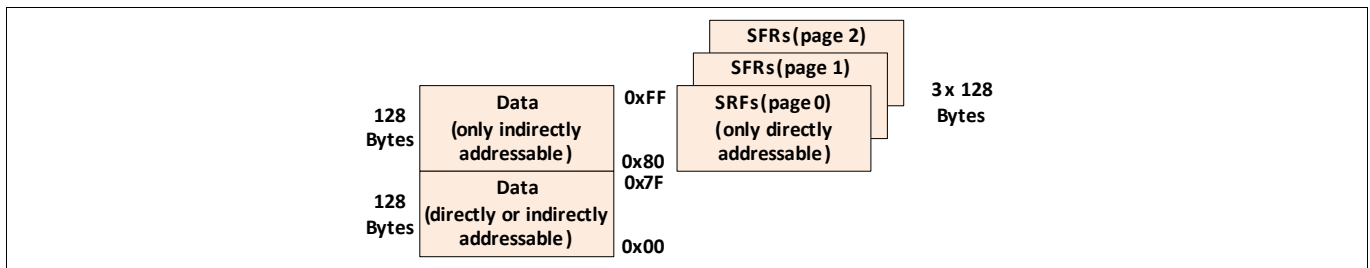

Figure 5-8 RAM organization

There are some restrictions in using the data RAM. Firmware library functions use certain RAM locations for internal operations (see ROM Library Guide). Furthermore the upper 128 byte of RAM are used exclusively by the transmission state machine during RF transmission. Unlike the retention RAM, the data RAM is not powered in power-down state and deep-idle state. The lower RAM bank is not powered in TX-low-power state.

Memory mapped RAM

There are 3 additional bytes of RAM which are mapped to the code memory range. These bytes are not belonging to the retention RAM area. Address of the first byte is 0xAFF8. The three RAM locations are intended for executing a user defined OpCode in order to address SFR indirectly, for instance. See [2] for details.

Associated registers:

- CPUSYS (PAGING0/1 for SFR bank switching)
- MMR0/1/2 (Memory Mapped Registers for execution of runtime programmable OpCode)

5.6.6 Retention SFRs

Many of the SFRs are implemented as retention registers, i.e. they are keeping their values in low power states like retention RAM. However, other than retention RAM they are all initialized by firmware after a system reset. Some internal retention SFRs are loaded with values from the Infineon config sector. They are refreshed after each device wake-up or resume as well.

Functional Descriptions

5.7 Power Supply and Reset Generator

The Power Supply and Reset Generator provides the voltage for different voltage domains:

- Analog domain
- Digital domain
- Voltage domain for retention RAM and SFRs
- Regulated voltage for RF power amplifier

Furthermore this functional block provides a reset signal on power-on and under-voltage for the wake-up controller (see [Chapter 5.2.5](#)).

Note: an external capacitor must be connected to VDDREG-pin in order to stabilize the internal voltage. This pin must not be used as voltage supply for external devices.

5.7.1 TX battery voltage detector

Part of the power supply block is the TX battery voltage detector. This detector monitors the battery voltage during RF transmission, i.e. when a frame is transmitted, but not during interframe delay. The detector is activated automatically by the transmission controller. If battery voltage drops below V_{MIN} (see [Table 2-10](#)) then flag BATTXOK is immediately set without time delay (apart from the analog signal propagation delay which is in the μs range). The bit may be checked by application code after resuming run state.

Associated register:

- DSR1 (bit BATTXOK)

5.8 Measurement Interface

The measurement interface block is the interface between the analog sensor signals and the digital signal conditioning domain of the SP40T. A multiplexer selects one of the following input signals for the 13 bit analog to digital converter:

- Pressure Sensor (located on separate MEMS chip)
- Accelerometer (located on separate MEMS chip)
- Temperature Sensor
- Battery Voltage Sensor

This block also includes a bond wire surveillance circuit which checks the integrity of the connections to the MEMS chip after each measurement.

5.9 RF transmitter

[Figure 5-9](#) shows a block diagram of the RF transmitter with associated SFRs. The transmission may be either controlled by the CPU (CPU mode) or by the transmission controller (TX-FSM). Some registers and bits only need to be accessed in CPU mode. They are marked with * in [Figure 5-9](#). The CPU mode is only implemented for the sake of compatibility with prior products. Since the CPU clock can cause spurs in the transmitted spectrum, in CPU mode transmission should only take place when the CPU is in idle state. Otherwise RF standards like ETSI and FCC may not be met. See chapter “User instructions” in the User Manual how to use CPU mode. This following description focuses on transmission using the transmission controller.

The RF transmitter receives data from the RF transmission controller via the data register RFD (in CPU mode RFD is directly loaded by application code for single byte transmission). As soon as a data byte is loaded into RFD, the RF power amplifier is activated and the Manchester/biphase encoder starts encoding. For carrier frequency generation the RF transmitter has a PLL circuit and a crystal oscillator operated with a 26 MHz standard quartz. The PLL is a Sigma-Delta (SD) fractional-N type which allows frequency modulation (FSK) by directly changing the PLL frequency. The transmitter also allows amplitude modulation (ASK) by modulating the VDDPA voltage.

Functional Descriptions

The transmitter supports the 315MHz and the 434MHz band. Part of the PLL is a VCO whose frequency depends on selected frequency-band, carrier frequency and temperature. Hence the VCO must be tuned prior to transmission. For this purpose the firmware function Lib_Serv_VCO_Tuning is available. The frequency band is selected via input parameter of Lib_Serv_VCO_Tuning and the carrier frequency registers must be set before calling this function.

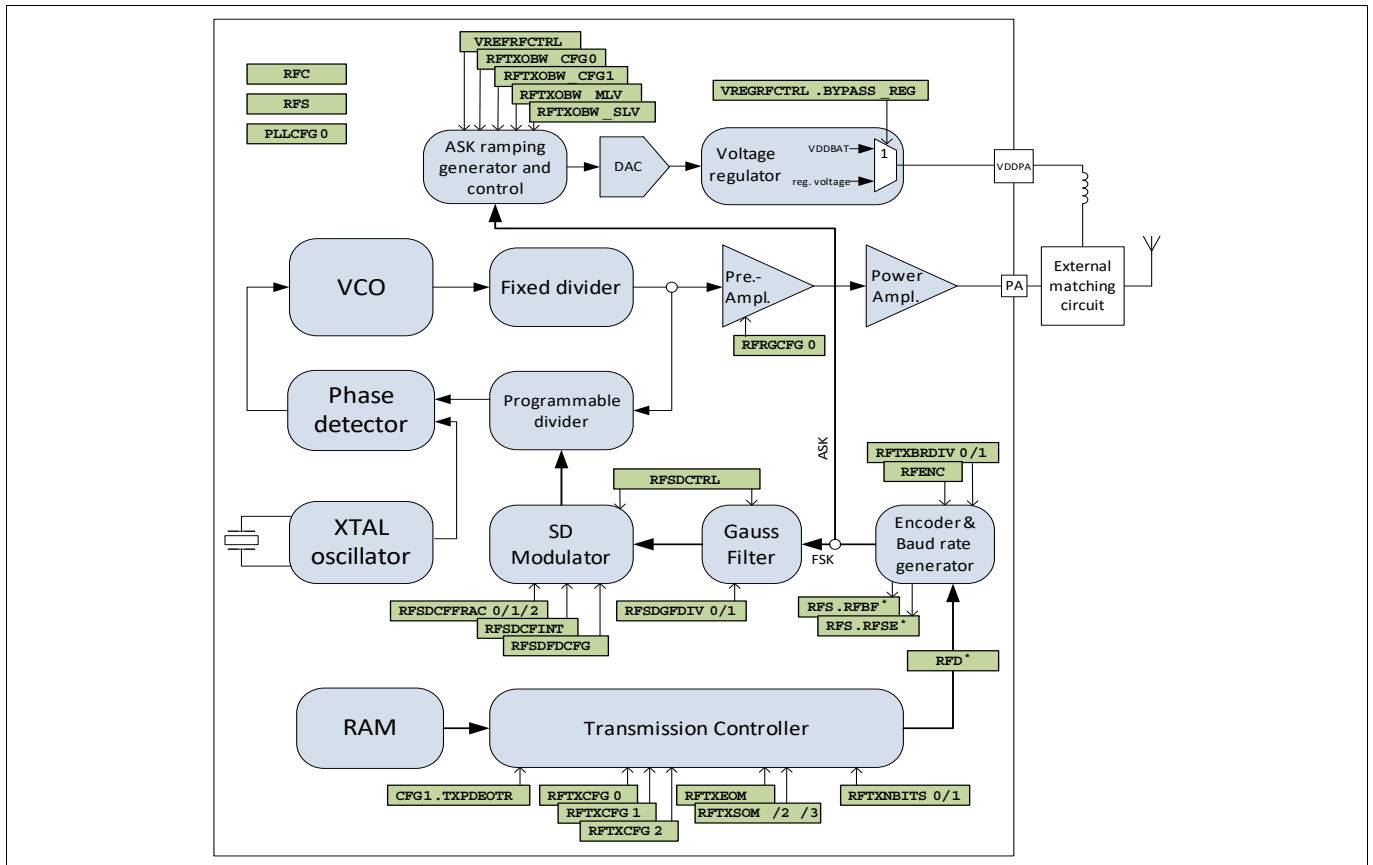

Figure 5-9 RF Transmitter block diagram

5.9.1 Manchester/Biphase Encoder

The Manchester/Biphase encoder automatically encodes data bytes to a Manchester or Biphase bit-stream beginning with the MSB. Encoding starts when a byte is loaded into the encoder TX data register (RFD). Also, if the bit ENPA is cleared, the encoder automatically switches on the RF power amplifier when the encoded data is shifted out. The encoder needs a clock signal which is provided by the Baud-rate generator, see [Chapter 5.9.8](#).

The encoder can be either used directly in application code by feeding data to RFD or indirectly by using the transmission controller. In this second case the RF data must be stored in a dedicated RAM location and the transmission controller manages the transfer of the RF data to the RFD register. Details see [Chapter 5.10](#).

There are several control bits that determine how the data is treated by the encoder. The three bits RFMODE determine the encoding scheme:

- Manchester
- Inverted Manchester
- Differential Manchester
- Biphase 0
- Biphase 1
- Chip Mode (NRZ)

Functional Descriptions

Chip Mode means that the data bits are not encoded, but sent directly to the modulator. This feature allows user defined encoding schemes, preambles and intended code violations. Note that in chip mode the bit time is only half time as in the other modes. Therefore the transmission of one byte in chip mode is completed already after 4 clock cycles. An example of the encoder output signal for the different modes is shown in **Figure 5-10**.

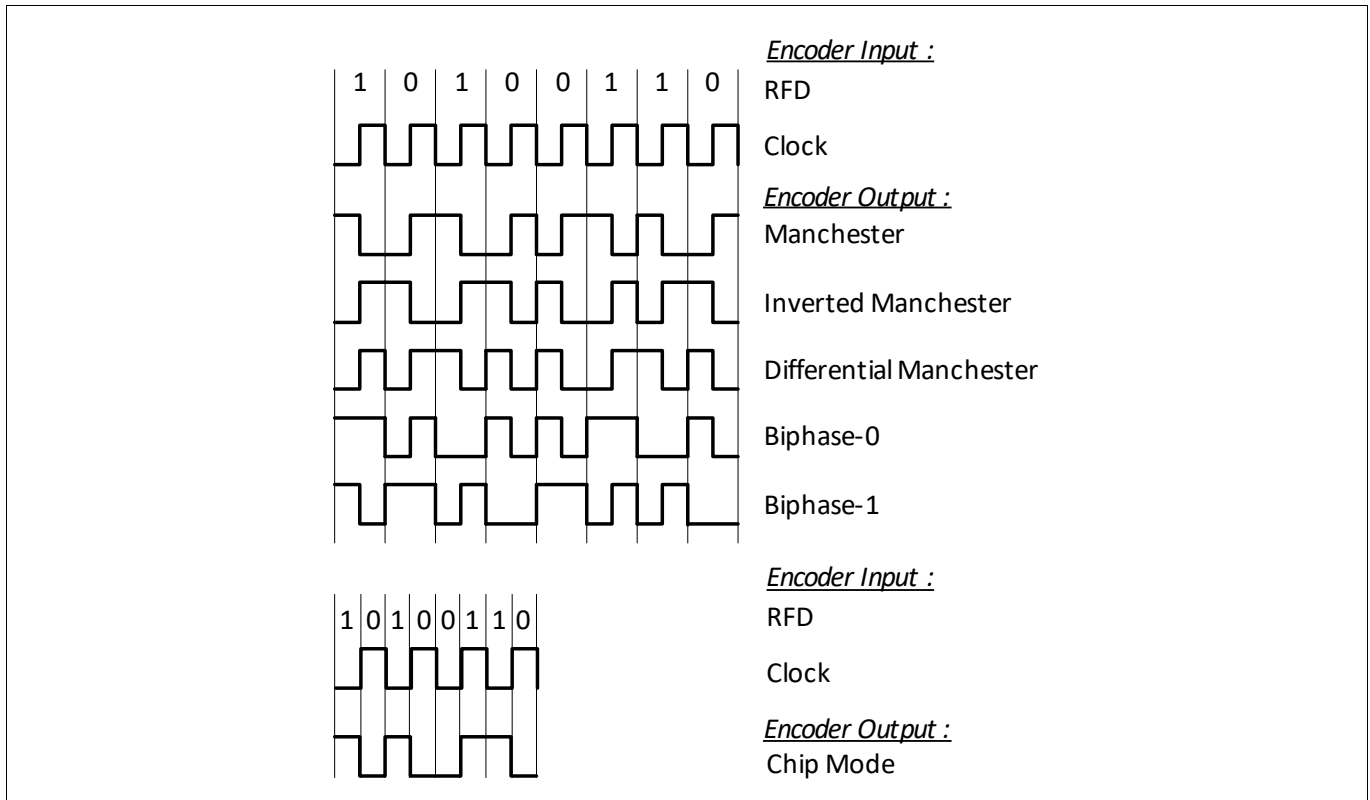

Figure 5-10 RF encoding schemes

The bit TXDD determines the output of the encoder before or after transmission. This bit only applies when ENPA is set, otherwise the RF power amplifier is automatically deactivated after transmission and the encoder output is meaningless. If the bit ITXD is set the encoder output is inverted. Finally, the 3 bits RFDLEN determine the number of bits of the RFD data byte to be transmitted beginning with the MSB. Default setting for RFDLEN is 7 meaning that all 8 bits are transmitted.

The encoder unit provides two status bits. The bit RFBF indicates that RFD is full. If this flag is set no data must be written to RFD. The bit RFSE indicates that all bits have been transmitted.

The encoder supports a monitoring function that automatically disables the RF power amplifier during transmission if the PLL goes out of lock (indicated by flag OOL) or the crystal oscillator is unstable (indicated by XFAIL). This function avoids out of band transmission. The status bit PADIS is set automatically if the RF amplifier is disabled either by PLL or XTAL fail. Note that these monitoring functions are disabled by default and should be enabled by setting bits ENPLLMON and XOSCPLLMON in order to avoid out-of-band emission.

Special function registers associated with the encoder are:

- RFD
- RFENC (fields RFMODE and RFDLEN, bits TXDD and ITXD)
- RFS (bits RFBF, RFSE, PADIS)
- RFC (bits ENPLLMON, XOSCPLLMON and ENPA)

Functional Descriptions

5.9.2 SD-PLL

For generation of the RF frequency the SP40T comes with a fractional-N Sigma-Delta-PLL (SD-PLL). A conventional PLL circuit has a divider with a fixed ratio for dividing down the output frequency in order to make it exactly the same as the reference frequency. In contrary to that, a fractional-N SD-PLL has a divider with a certain range of divider ratios. The selection of the divider ratio is carried out by a sigma delta modulator. The sigma delta modulator provides a data stream where each data word means a certain divider ratio. Due to the integrative behavior of the PLL loop the output frequency becomes the reference frequency multiplied with the average divider ratio determined by the SD data stream.

The advantage of this method is that the output frequency can be adjusted with a very high resolution. Furthermore the ratio of output and reference frequency does not need to be an integer value. Hence it is possible to use the same crystal for different frequency bands, namely the 315 band and the 434 MHz band.

The SP40T allows setting the RF center frequency with a 12 Hz resolution. An eight bit value PLLINT[7:0] is used for determining the integer part of the frequency and a 21 bit value PLLFRAC[20:0] for the fractional part according to **Equation (5.1)**.

$$f_{RF_center} = f_{XTAL} \left(PLLINT + \frac{PLLFRAC}{2^{21}} \right) \tag{5.1}$$

Registers used for frequency setting are:

- RFSDCFINT (PLLINT)
- RFSDCFFRAC0 (PLLFRAC)
- RFSDCFFRAC1 (PLLFRAC)
- RFSDCFFRAC2 (PLLFRAC)

Other registers:

- RFS (Status bits OOL , XFAIL and PADIS)
- RFC (bits XOSCPLLMON and ENPLLMON)

5.9.3 FSK Modulator

The FSK modulator is part of the SD-PLL. The SD modulator generates a data stream that corresponds to the FSK low frequency if the FSK data line is low and a data stream that corresponds to the FSK high frequency if the data line is high. FSK high frequency and FSK low frequency are determined by an 8 bit value FDEV according to **Equation (5.2)**.

$$\begin{aligned}
 FSK_{HIGH} &= f_{RF_center} + FDEV \frac{95 f_{XTAL}}{2^{23}} \\
 FSK_{LOW} &= f_{RF_center} - FDEV \frac{95 f_{XTAL}}{2^{23}}
 \end{aligned}
 \tag{5.2}$$

Related register:

- RFSDFDCFG (FDEV)

5.9.4 Gaussian filter

In order to reduce the occupied bandwidth (OBW) in case of FSK-modulation a Gaussian filter for mitigating the steps between the two FSK-frequencies is implemented. The Gaussian filter is enabled by choosing GFSK option when calling Lib_Serv_Config_RF_Transmission. The filter effect decreases with increasing filter oversampling rate in relation to signal chip-rate. The sample-rate is determined by the 12 bit value GFDIV. A good compromise

Functional Descriptions

between modulation shaping and RF sensitivity loss is an oversampling rate of 16. [Equation \(5.3\)](#) provides the value of GFDIV for a fixed oversampling rate of 16 and a given value of BRDIV. For the relation between BRDIV and Baud-rate / chip-rate see [Chapter 5.9.8](#).

(5.3)

$$\text{GFDIV} = \frac{(\text{BRDIV} + 1)}{4} - 1$$

Associated registers are:

- RFSDBGFDIV0 (GFDIV)
- RFSDBGFDIV1 (GFDIV)

5.9.5 RF Power Amplifier

The power amplifier is intended to be operated as class-E amplifier which has a higher efficiency than class C operation. The operation mode is mainly determined by the matching network. (See [Chapter 6](#) for a matching network proposal.) In order to provide a constant RF output power independent from battery voltage, a voltage regulator for the RF amplifier is implemented. The voltage is available at VDDPA pin. However, by setting bit BYPASS_REG, it is still possible to operate the transmitter with unregulated battery voltage.¹⁾

If the transmission controller is used (FSM mode, [Chapter 5.10](#)) then the RF power amplifier (PA) is automatically switched on and off for transmission. If the transmission is controlled by application code (CPU mode) then the power amplifier needs to be controlled by switching bit ENPA (see User Manual, chapter User Instructions).

For the sake of low occupied bandwidth the RF power should not be instantly switched, but ramped. In case of ASK modulation the voltage at VDDPA pin is ramped for this purpose, see [Chapter 5.9.6](#). In case of FSK modulation a different power shaping mechanism is used. Here the impedance of the PA is ramped. Ramping time for PA power on and off for FSK is controlled by bitfield RTIME.

Important registers associated with the PA are:

- RFC (bit ENPA, only for CPU mode)
- VREFRCTRL (supply voltage for PA pin)
- VREGRCTRL.BYPASS_REG (enables battery voltage at VDDPA)
- RFRGCFG0 (RTIME, only for FSK modulation)

Attention: In order to prevent electrical overstress of the PA stages the transmitter supply voltage must always be taken from VDDPA pin. It is not allowed to directly connect the transmitter to an external voltage (=battery voltage).

5.9.6 ASK modulator and ASK ramping

The regulator for the VDDPA voltage is controlled by a DAC which allows exact voltage adjustment. In case of FSK or OOK modulation a constant voltage is generated at VDDPA pin during transmission. This constant voltage is controlled by register VREFRCTRL. In the case of ASK modulation the voltage at VDDPA pin is trapezoidal modulated. The trapezoid voltage is controlled by the RFTXOBW registers; VREFRCTRL has no function for ASK modulation.

1) Note that all RF-related parameters in this datasheet apply when using the voltage regulator (BYPASS_REG = 0). When setting the bit BYPASS_REG the user has to make sure that all parameters can still be met.

Functional Descriptions

Register RFTXOBW_SLV defines the VDDPA voltage during ASK-low phase, RFTXOBW_MLV the voltage during ASK-high phase. It is recommended always to set the voltage in ASK-low phase to zero. Registers RFTXOBW_CFG0/1 are used for defining the ramp between ASK-low and ASK-high level. The ramping slope should be chosen such that the occupied band width (OBW) requirements are fulfilled.

The formula for calculation of the ramp up or ramp-down time is as follows:

(5.4)

$$t_{r_up} = t_{r_down} = \frac{(HLEVEL - LLEVEL)}{f_{XTAL} (SLOPE + (RATE_DIV + 1) / 16)}$$

Following registers are used for ASK level and ramping control:

- RFTXOBW_CFG0 (field RATE_DIV)
- RFTXOBW_CFG1 (field SLOPE)
- RFTXOBW_MLV (field HLEVEL defines voltage level of ASK high)
- RFTXOBW_SLV (field LLEVEL defines voltage level of ASK low)

5.9.7 Crystal Oscillator

The SP40T has a Pierce oscillator for generating the reference frequency for RF transmission. The oscillator comprises an amplitude regulation circuit in order to overcome the tradeoff between oscillator current consumption and oscillator stability. The amplitude regulation circuits controls the oscillator’s bias current. The oscillator features an optional boost circuit which minimizes the duration and tolerance of start-up time. Although it is disabled by default, it is recommended to always enable the boost circuit.

With a Pierce oscillator the crystal is operated in parallel mode. This means that the external load capacitor C_L acts as a parallel capacitance. Hence the resonance frequency of the oscillator is given by following formula:

$$f_{res} = \frac{1}{2\pi \sqrt{L \frac{C(C_0 + C_L)}{C + C_0 + C_L}}} \tag{5.5}$$

L , C and C_0 are the equivalent lumped elements of the crystal which are available from the crystal manufacturer. For the ideal circuit in **Figure 5-11** the load capacitance is calculated as $C_L = C_{ext} / 2$. Note that in a real circuit the PCB- and pin-capacitances need to be considered for the total load capacitance as well.

Functional Descriptions

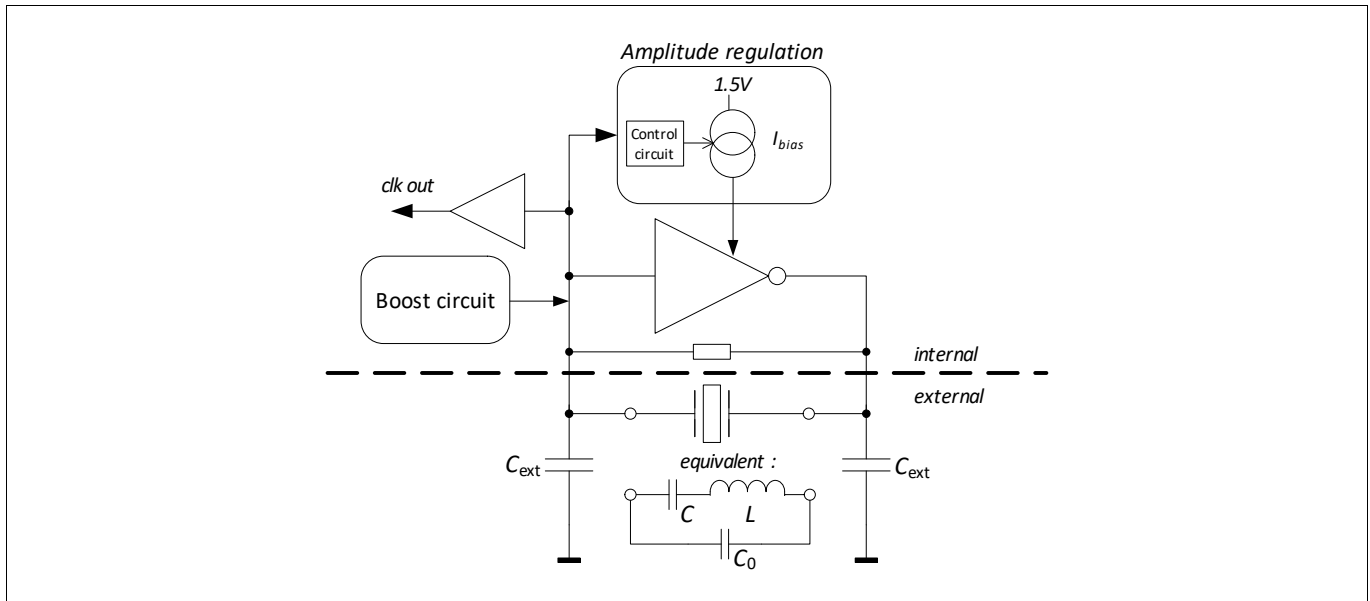

Figure 5-11 Pierce Oscillator

Associated registers are:

- CLKCFG.XSTABLE
- CLKCFG.XBOOST (set this bit in order to enable the boost circuit)
- RFTXCFG2.RFSTUPTIME (crystal oscillator start-up time for transmission controller)

5.9.8 RF Baud-Rate Generator

The RF Baud-rate generator is a programmable divider that directly generates the Baud-rate by dividing down the crystal clock. Variable Baud-rates from 4000 to 20000 bit/s are supported. The Baud-rate is determined by a 16 bit value BRDIV[15:0] according to **Equation (5.6)**. (See also [2]).

(5.6)

$$\text{Baud rate} = \frac{f_{XTAL}}{8(\text{BRDIV} + 1)}$$

Note: throughout this document Baud-rate means bit-rate of a Manchester coded signal. For a Manchester coded signal the chip-rate is twice the bit-rate. Hence, switching from Manchester to NRZ coding for a fixed value of BRDIV means same chip-rate, but doubling the bit-rate.

Associated registers are:

- RFTXBRDIV0
- RFTXBRDIV1

5.10 RF Transmission Controller

The RF transmission controller is a state machine (FSM) for handling RF transmission without CPU support. For telegram transmission the payload of the RF telegram needs to be generated in application code and stored in the upper RAM bank, starting at address 0x80. Then the RF transmission controller must be enabled and the device can be switched into TX low power state for power saving. In this state the CPU is disabled, the RF state machine directly accesses to the RAM, and automatically transfers the data bytes of the payload to the

Functional Descriptions

Manchester/Biphase encoder. The RF transmission controller also carries out the power management for RF transmission by controlling the PLL circuit, the crystal oscillator and the encoder.

The transmission controller allows sending of telegram frames consisting of a start of message header, then a defined number of repetitions of the payload and finally an end of message terminator. Then, depending on configuration settings, the device resumes run state or goes into power-down state.

The transmission controller supports sending a sequence of such telegram frames separated by a precisely defined delay (interframe delay). For this purpose an interframe delay time can be defined in application code and the transmission controller can be configured for resuming run state after telegram frame transmission. In this case the interframe timer is started automatically after frame transmission and in parallel the device resumes run state (i.e. the interframe timer is still running in the background). Now payload and interframe delay can be modified and thereafter the device is switched back into TX low power state by application code. (It is mandatory that the device goes back into TX low power before the interframe-delay elapses.)

Note that modifying interframe delay time does not affect the current interframe delay cycle. It will be effective only for the next interframe delay cycle. When the current interframe time elapses the modified telegram frame is transmitted automatically and the loop starts again.

For leaving this loop either the interframe time can be set zero by application code after resuming run state. In this case one more telegram frame will be transmitted before the loop is exited. Alternatively the bit FSMSTOP can be set by application code. In this case the state machine is stopped immediately.

The described flow is shown in [Figure 5-12](#). The procedure for configuration of the transmission controller and transmitter is described in [\[1\]](#).

Registers associated with the transmission controller are:

- CFG1.TXPDEOTR (selects device state after transmission completed)
- RFTXCFG0 (start/stop TX-FSM and control of end-of-message pattern)
- RFTXCFG1 (control of start-of-message pattern)
- RFTXCFG2 (field NFRAMES: number of payload repetitions)
- RFTXEOM (definition of end-of-message pattern)
- RFTXIFD0/1 (set via Lib_Serv_Interframe_Timer_Calib, but may be cleared by direct access)
- RFTXNBITS0/1 (telegram bit length)
- RFTXSOM / RFTXSOM2 / RFTXSOM3 (definition of start-of-message pattern)

Functional Descriptions

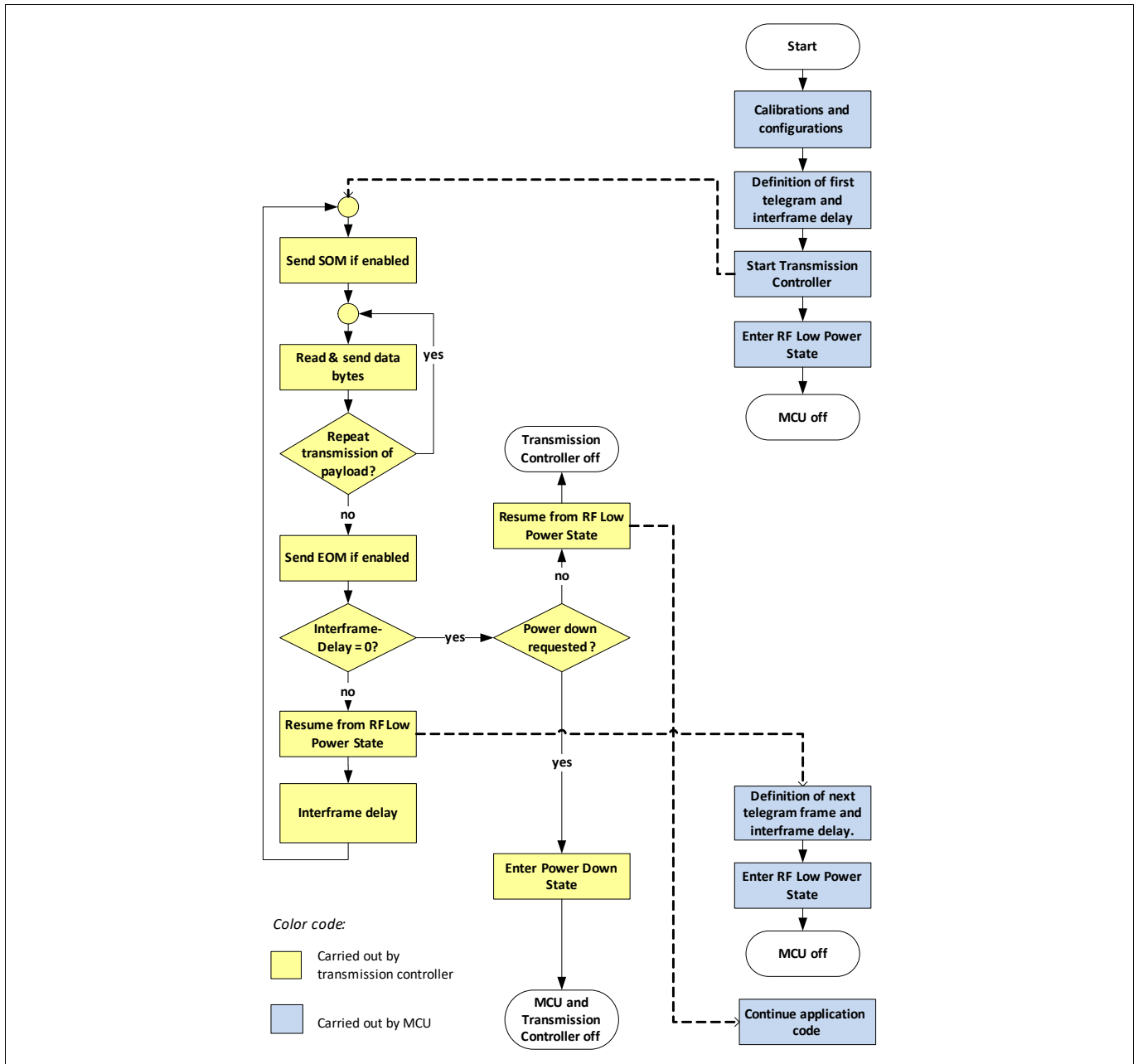

Figure 5-12 RF Transmission Controller flow diagram

5.10.1 SOM and EOM Feature

The transmission controller can be configured for sending an 1 to 24 bit long start of message (SOM) pattern prior to transmitting the payload and for appending an 1 to 8 bit long end of message (EOM) terminator at the end of the telegram. These bits are transmitted uncoded (NRZ) with the chip-rate, i.e. twice the selected Baud-rate.

Figure 5-13 shows an example of a 9.6 kBaud transmission of a telegram consisting of a 3 bit SOM pattern, followed by one Manchester coded data byte, and terminated by a 3 bit EOM pattern. In this example the SOM and the EOM generate intended Manchester code violations.

Functional Descriptions

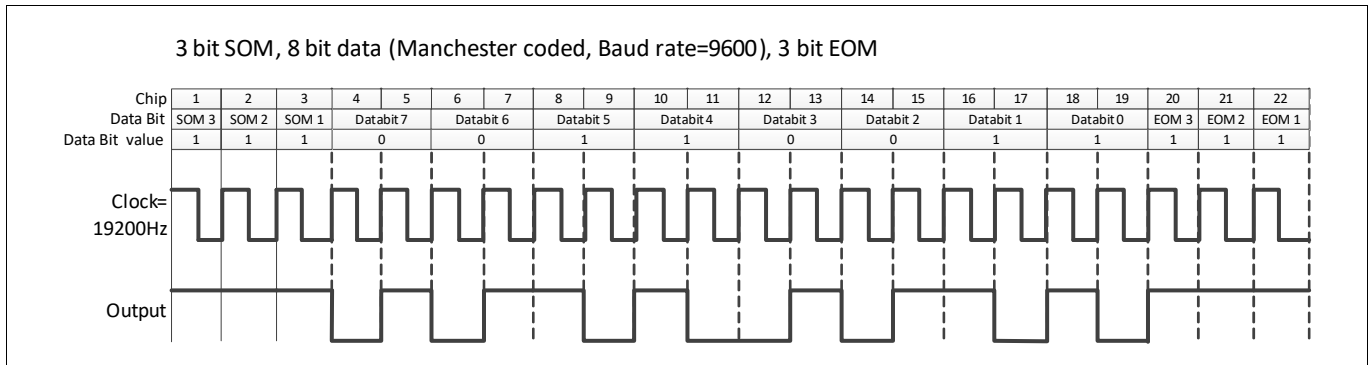

Figure 5-13 Example for RF Transmission with SOM and EOM

5.10.2 Voltage measurement at end of transmission

The transmission controller can be configured for automatic battery voltage measurement at the end of the RF telegram, i.e. during the last transmitted byte. If the telegram consists of several frames separated by interframe delays then the voltage measurement is only possible at the end of the last frame. The last frame is recognized by the transmission controller by checking the interframe delay time for zero. As can be seen in [Figure 5-12](#) the multi frame loop is aborted if the interframe delay is zero. Therefore the last frame can be identified by zero interframe delay.

Consequently, if voltage measurement during transmission is required, multi-frame telegrams must not be aborted by setting bit FSMSTOP after resume from TX-low power but only by setting interframe delay zero prior to the last frame.

In order to read the voltage value the ROM library function `Lib_Acq_Meas_Supply_Voltage()` must be called right after resuming from TX low power after the last frame. Therefore voltage measurement at end of transmission is not possible if the transmission controller is configured for entering power-down after transmission. See also [\[1\]](#) and [\[2\]](#) for more details.

5.11 LF Receiver

The LF Receiver is designed for a carrier frequency of 125 kHz and for receiving Manchester encoded data telegrams with a typical Baud-rate of 3900 bit/s. It is used for wake-up of the SP40T from power-down either by carrier detection (carrier wave detection mode) or telegram pattern match (telegram reception mode) for the following reasons:

- Triggering a pressure measurement (pressure on demand function)
- Triggering the transmission of a unique ID number (wheel localization feature)
- Triggering of operation modes, e.g. diagnosis modes for production and maintenance
- Update of user configuration data via LF

The LF receiver can be configured for carrier detection with different detection ranges that have specified no-detection and always-detection thresholds. If no further filtering is configured (e.g. carrier pulse width measurement) then in this configuration only the analog part of the LF Receiver is activated. Upon carrier detection the LF Receiver generates a maskable wake-up.

Alternatively the LF receiver can be configured for telegram detection. In this configuration the digital baseband is activated. The digital baseband decodes the received Manchester telegrams and generates a wake-up either on synchronization pattern match, on wake-up pattern match or on data reception (i.e. data buffer full or end of message). All three wake-up events have dedicated wake-up flags and are independently maskable.

Functional Descriptions

The LF receiver can be active in all device states, apart from thermal shutdown state. In TX low power the device will not resume due to any LF event in order to assure continuous RF transmission. In case of an LF event during TX low power it will only be stored in WUF register.

5.11.1 LF Analog Front End (AFE)

Figure 5-14 shows the analog front end of the LF receiver. The differential LF input (pins LFP and LFN) are protected by standard ESD structures. It is followed by a variable attenuator which is part of an active amplitude gain control (AGC). A high pass filter is implemented for blocking DC signals from the previous stages. The subsequent RSSI generator provides a signal with a logarithmic dependency on the envelope of the LF signal. For modulated LF signals this stage serves as demodulator. In the carrier detector the RSSI signal is compared to a certain threshold. The output signal of the carrier detector is fed to the digital baseband for further processing. If amplitude modulated signals are received, a data slicer is used for converting the RSSI signal into a data stream for baseband processing. The data slicer threshold is adapted automatically to the signal level.

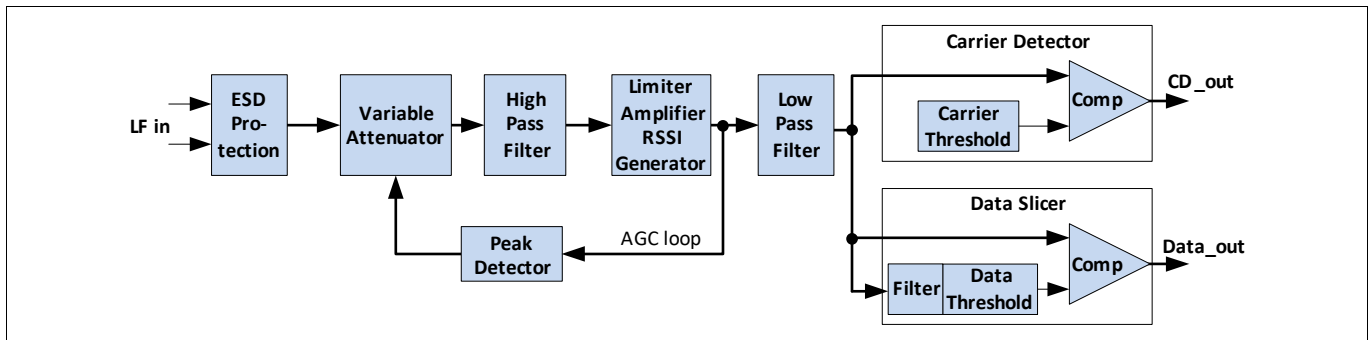

Figure 5-14 Analog front end of LF receiver

Several special function registers for adjusting the receiver sensitivity are implemented. Nevertheless the user does not need to care for these registers since they are set by a dedicated firmware function (Lib_LF_Sensitivity). This function loads register settings from the IFX configuration sector which contains manufacturer calibration data and just needs to be called in application code with the desired sensitivity level as parameter [1].

5.11.2 LF Digital baseband (DBB)

Part of the LF receiver is the digital baseband which processes the output signals from the detector blocks of the analog front end. **Figure 5-15** provides an overview of the digital part. It is clocked with the 90 kHz oscillator and performs following tasks:

- Carrier pulse width detection
- LF carrier frequency measurement
- Synchronization sequence recognition
- LF wake-up pattern match recognition
- LF data reception including Manchester decoding

Functional Descriptions

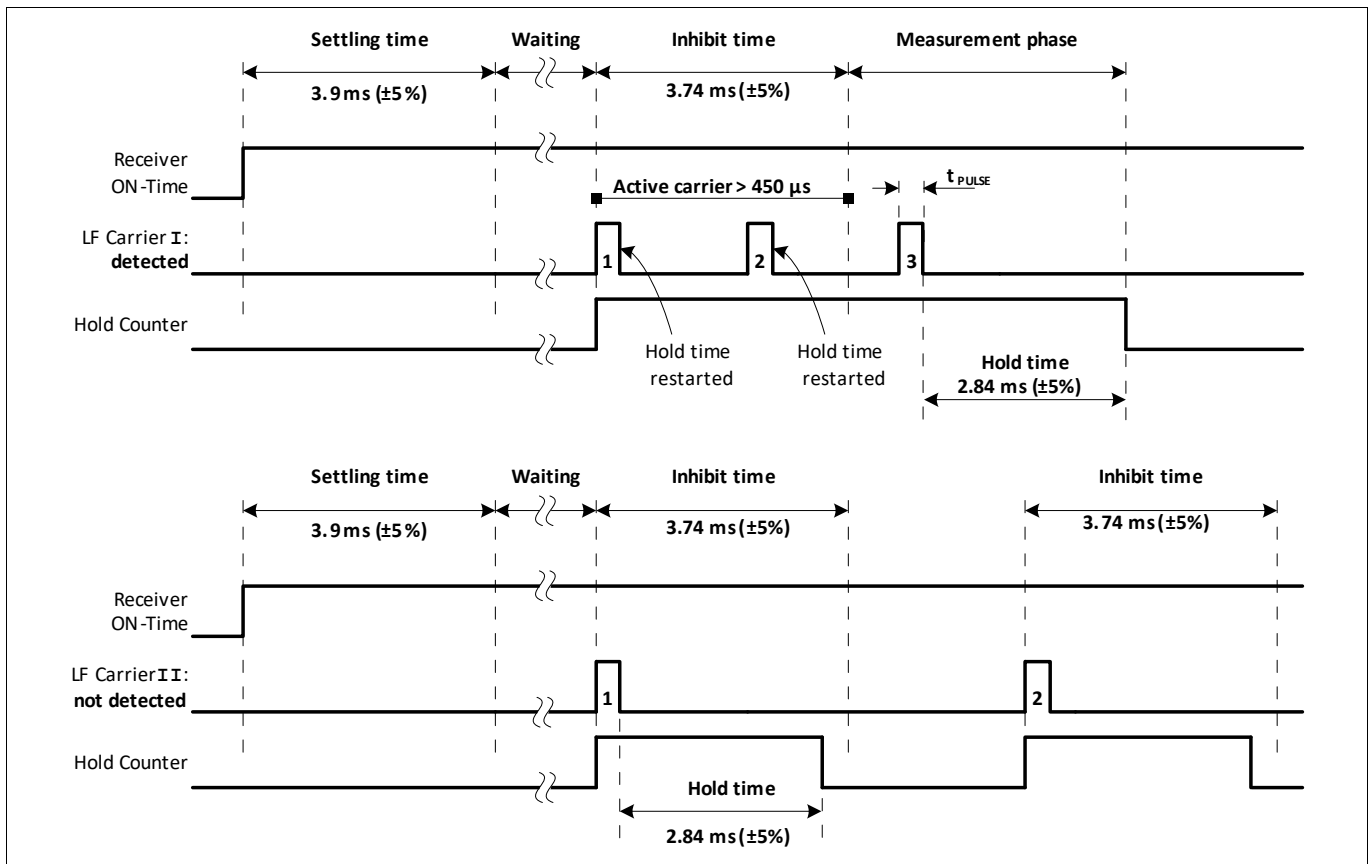

Figure 5-16 Carrier pulse detection timing

LF wake-up pattern recognition

The LF receiver can be configured for recognition of one or two different wake-up patterns. The pattern length is either 8 or 16 bit. Following registers are associated with this function:

- LFDPCFG (for definition of pattern number (one or two) and pattern length)
- LFDPOL and LFDP0H (definition of pattern 0)
- LFDP1L and LFDP1H (definition of pattern 1)

Synchronization pattern

The LF receiver expects a fixed synchronization pattern which cannot be changed. It is shown in [Figure 5-17](#). The synchronization pattern contains code violations with regard to Manchester coded data in order not to be mixed up with data bytes.

LF data reception

The LF receiver can receive Manchester coded data bytes. The data is stored in a 7 byte data buffer. If more than 7 bytes are received the buffer is overwritten (ring buffer). The receiver can be configured for wake-up after a data byte has been written into a user-defined address of the data buffer.

Following registers are associated with data reception:

- LFDRXBYTE0 to LFDRXBYTE6 (data buffer)
- LFDERRORFLAGS (indicates overwriting condition for each data register)
- LFDSTATUSFLAGS (indicates pending data for each data register)

Functional Descriptions

- LFDBUF CFG (definition of data-buffer address for wake-up)

5.11.3 LF Telegram

LF telegrams must start with a preamble in order to let the receiver establish an appropriate threshold for data demodulation. Preamble length must match LF Data Threshold settling time (parameter 23.7). It is followed by a defined synchronization pattern. Following the sync pattern comes an optional 8 or 16 bit long wake-up ID and an arbitrary number of data bytes. Wake-up ID and data bytes are Manchester encoded.

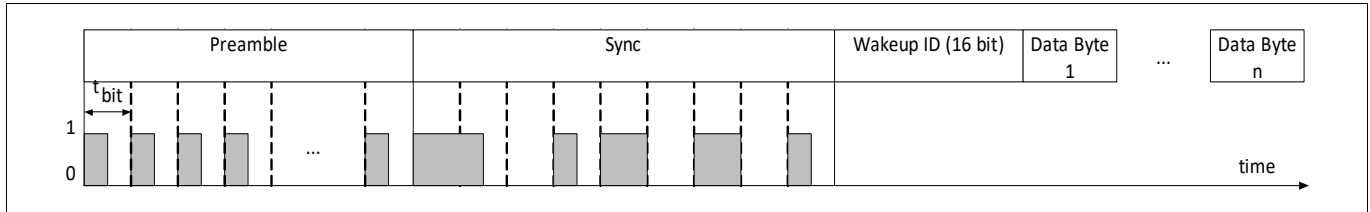

Figure 5-17 LF telegram modulated on a 125 kHz carrier (shaded areas)

5.11.4 LF state machine

The LF receiver is controlled by a state machine. [Figure 5-18](#) shows the corresponding flow diagram and how the receiver behaves for the different operating modes:

- Carrier wave detection mode (CWDM)
- Data reception mode (DRM)
- Toggle mode (toggle between CWDM and DRM)

The modes are selected in application code by setting bits LFBBM accordingly [\[2\]](#).

If the LF receiver is deactivated, the state machine waits for activation in loop (1) in the flow diagram. The condition for activating the LF receiver is described in [Table 5-5](#).

Table 5-5 Activation of LF Receiver

Bit ENLFRX	Bit ENOOTIM	ON-OFF Timer	LF Receiver
0	0	disabled	always deactivated
1	0	disabled	always activated
1	1	ON phase	activated
1	1	OFF phase	not activated

In many applications the LF receiver is controlled by the ON-OFF-Timer in order to reduce current consumption. Since LF signals are asynchronous to LF receiver timing, certain actions are not simply interrupted when the ON-time elapses. Other actions are immediately terminated. This is illustrated in [Figure 5-18](#) by different colors.

If the LF receiver is switched on first time in application code by setting bit ENLFRX the LF state machine is automatically initialized. As can be seen in [Figure 5-18](#) after certain LF wake-up events the state machine waits for initialization (“Wait for init”). In this case application code needs to re-initialize the LF state machine by setting bit LFINIT before switching the device back into power-down. Without re-initializing the LF receiver will not trigger any more wake-up event. LFINIT is cleared automatically after initialization. If the ON-OFF timer is used the re-initialization will be carried out automatically during the OFF cycle. Note that all wake-up events of the data reception mode disable the ON-OFF timer by clearing ENOOTIM. Hence, if the ON-OFF timer is used, ENOOTIM and LFINIT must both be set in order to fully re-initialize the LF receiver configuration after wake-up.

Associated register:

Functional Descriptions

- LFDRXCFG (bits LFBBM for selection of LF receiver mode)
- LFRXC (bits ENOOTIM, ENLFRX and LFINIT)

Carrier wave detection mode (CWDM)

In this mode a wake-up is generated if a received LF carrier fulfills all of the following criteria:

- I. Amplitude criterion, i.e. amplitude must exceed a selectable level
- II. Duration criterion, i.e. carrier duration must exceed a selectable level
- III. A valid carrier according to criteria I to II is detected in a selectable number of consecutive ON periods

The CWDM is depicted by the middle branch of the flow diagram. After activation of the receiver and if CWDM is selected the state machine waits in loop (2) for a valid carrier amplitude. As soon as the amplitude criterion is fulfilled, measurement of carrier-duration is started, and in parallel amplitude is still monitored. If one of the two criteria is violated the state machine restarts searching valid amplitude, loop (3). If the ON time elapses during loop (2) or (3) the Carrier Detection Counter (CDC) for criterion III is cleared and the state machine returns to loop (1). If during the On-time both criteria I and II are fulfilled, the CDC is incremented. Then the counter is checked if criterion III is met. If yes, an LF-carrier-detect wake-up is triggered and the state machine waits for initialization by application code or On-time elapsing (4a). If not, the LF receiver is deactivated in order to save energy and the state machine waits in loop (4b) until remaining ON time elapses. In both cases the state machine returns to loop (1) after ON-time elapses. Loop (4b) is implemented in order to make sure that only one carrier detection occurs during ON time.

Associated register:

- LFDCCOUNT (Threshold value for carrier detection counter)

Data reception mode (DRM)

In this mode a wake-up is generated if a received LF carrier fulfills the following criteria:

- I. Synchronization (sync) sequence detected
- II. User defined Wake-Up pattern detected
- III. Optional: Data buffer filled with a selectable number of bytes
- IV. Optional: Code violation detected during data reception

Criterion I must always be fulfilled for wake-up. Criteria II to IV are optional.

The DRM is illustrated in the right branch of the diagram in [Figure 5-18](#). This mode starts with sync pattern search, loop (5). This loop is terminated as soon as the ON time elapses. After a valid sync pattern has been detected, a sync event is triggered and the receiver stays activated in order to check for the other criteria II to IV, even if the ON time elapses. Next, the wake-up pattern search starts. This search terminates if a certain time, depending on Baud-rate and pattern length, elapses. In this case sync search restarts, loop (8). Wake-up pattern search is also terminated by a Manchester code violation, loop (6). If a valid wake-up pattern is detected the maskable LF-Pattern wake-up is triggered. If no data reception is required the LF receiver can be deactivated in application code after this wake-up. If still activated, the receiver proceeds with data reception.

During data reception the 7 byte data buffer is filled with data in a ring buffer manner. Data reception terminates if a Manchester code violation is detected, i.e. if no more valid data is received. Then a corresponding end of message (EOM) wake-up is triggered (if not masked out), the ON-OFF timer is disabled and the receiver waits for initialization by application code. Back in run state the data buffer can now be read out. If the EOM wake-up is masked out and ON time remains, the receiver restarts sync search, loop (7).

The optional LF-Buffer-Full wake-up allows wake-up upon writing to a selectable address of the data buffer. This wake-up is intended for reception of more than 7 bytes. After LF-Buffer-Full wake-up the data buffer can be read out continuously by application code because the receiver stays active and data reception continues, loop (9).

Functional Descriptions

Associated register:

- LFDRXS0 (bit DECERR indicates a Manchester code violation)

Toggle Mode

In this mode the receiver toggles between DRM and CWDM from ON cycle to ON cycle (see left branch of the flow diagram). The DRM and CWDM can be operated with different sensitivity levels. Therefore, for configuring toggle mode, the function Lib_LF_Sensitivity() needs to be called twice, once with parameter Type=0 for CWDM and once with Type=1 for DRM.

Functional Descriptions

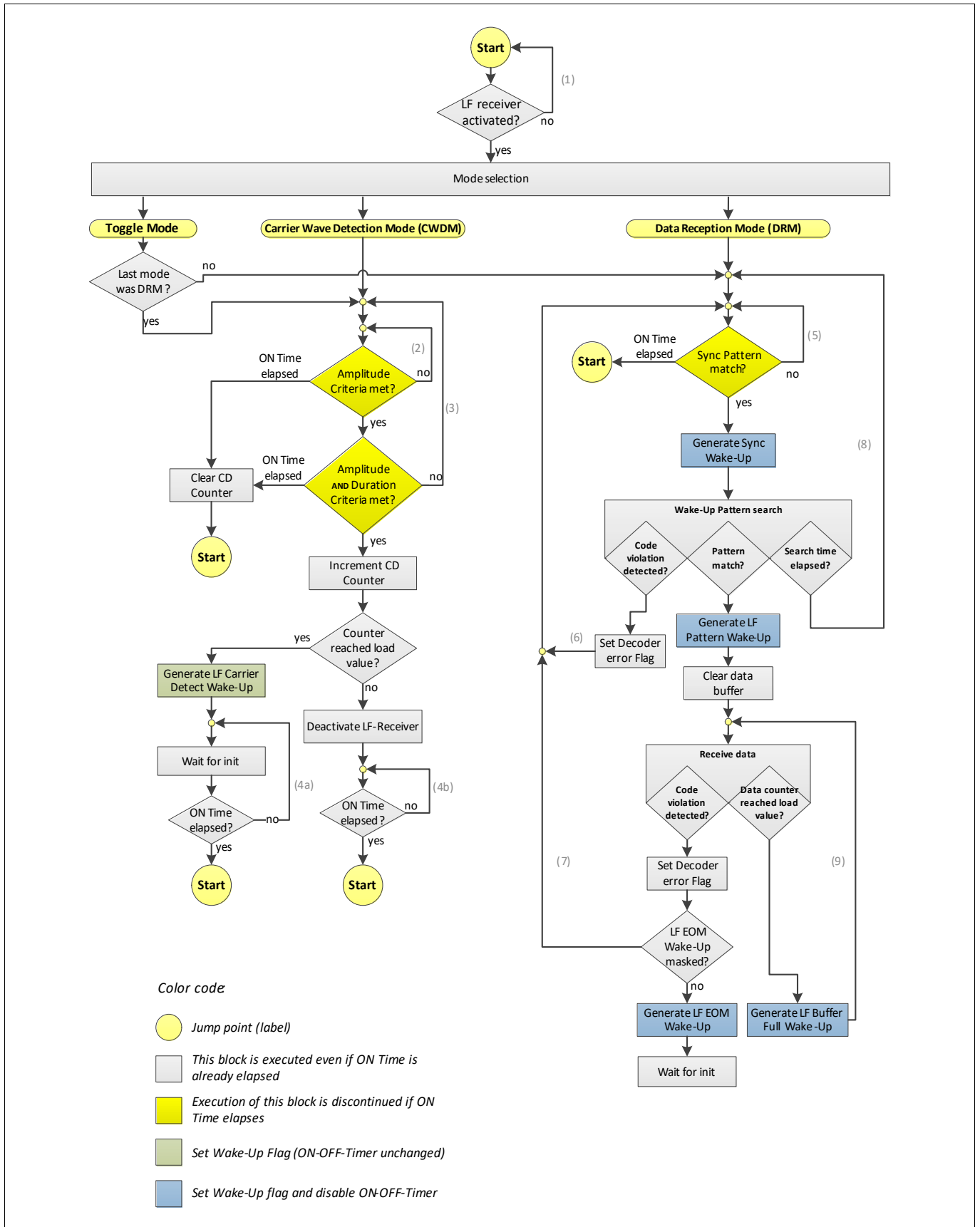

Figure 5-18 LF receiver flow diagram

Functional Descriptions

5.12 I/O-Port

The SP40T features four general purpose I/O ports that can be accessed in application code via SFR. The ports PP0 and PP1 are shared with the two I²C lines, SCL and SDA, respectively. The I²C interface is compatible with Fast-Mode standard. The device powers on with I²C interface enabled. Hence, within a limited time interval right after power on, the operating mode of the SP40T can be selected by sending a certain I²C command for selecting normal mode, program mode, debug mode or a manufacturer reserved test mode, respectively. If no I²C command is received before the time interval ends the device powers on in normal mode.

Furthermore port PP2 can be configured for device wake-up from power-down state or resume from idle state by an external digital signal. PP2 wake-up may be configured as high- or low-level sensitive. However, it is strongly recommended to use only high-level triggered wake-up and use low-level for quiescent state in a battery powered application. This is because the leakage current into PP2 is much higher for high-level than for low-level. For optimal immunity to external electromagnetic fields it is recommended not to connect unused general purpose I/O pins and configure it as output with output level "1". Used pins should be blocked with a 10pF ceramic capacitor, placed as close as possible to the pin.

If the hardware UART is enabled PP2 is used for the RX signal and PP3 for the TX signal.

Registers associated with the I/O port are:

- P1DIR
- P1OUT
- P1SENS
- P1IN

Application Circuit

6 Application Circuit

A typical application circuit is shown in **Figure 6-1**. The external LF circuit connected to pins 8 and 9 needs to be adjusted to the LF antenna actually used and to the desired LF Baud-rate. In this example an LF ferrite coil from Coilcraft has been chosen and an LF Baud-rate of 3900 bit/s (Manchester encoded) has been assumed.

The RF matching network connected to pin 12 amongst others strongly depends on employed antenna type, PCB material and layout. Hence in this example only the network topology for matching the output to an electrical antenna is proposed but no values are given. In practice an estimation of the component values of the matching network are derived using simulation tools. With these starting values the matching circuit is assembled on final PCB. Subsequently an iterative tuning of the values is performed where the emitted RF power is monitored with a spectrum analyzer.

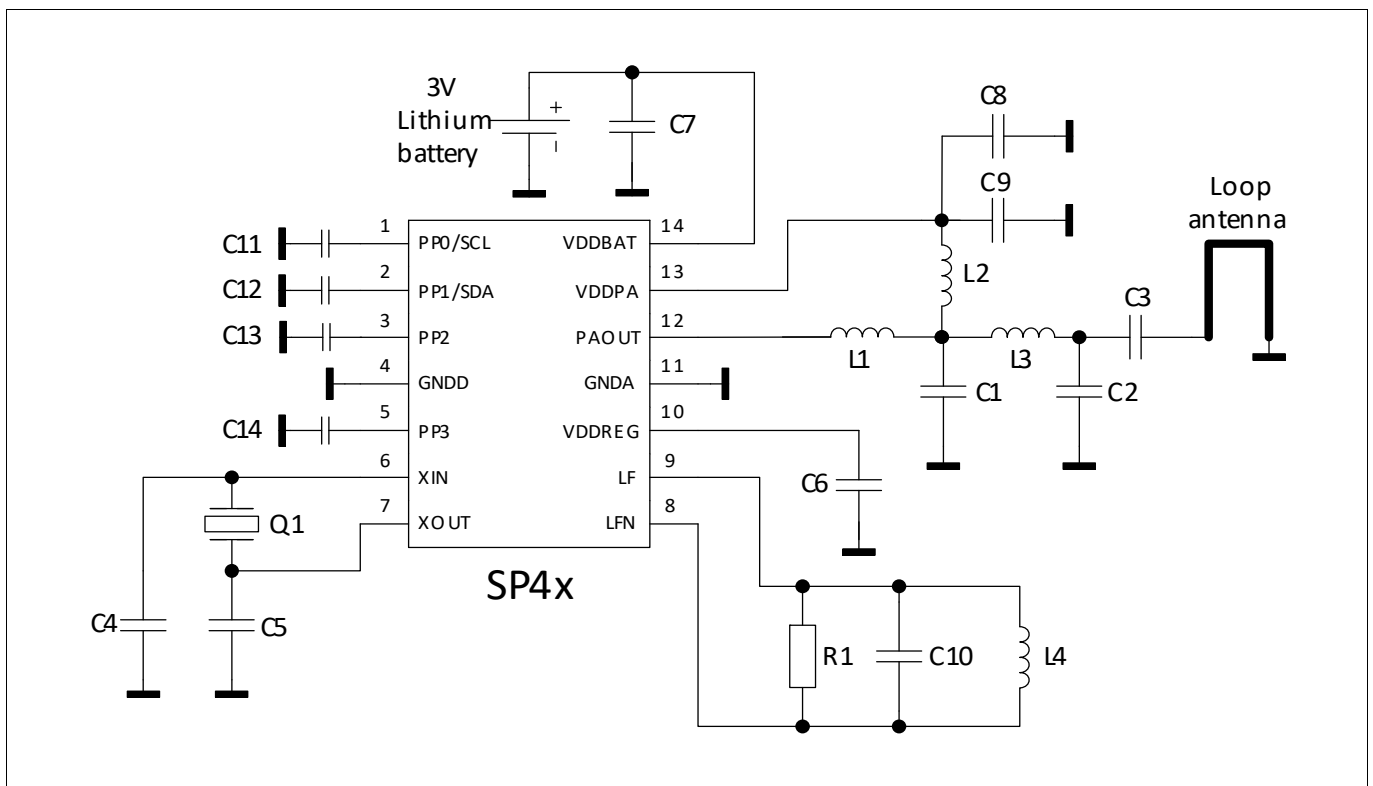

Figure 6-1 SP40T Application Circuit

Table 6-1 Application circuit component values

Unit	Min	Nom	Max	Unit	Comment
C1, C2, C3, L1, L2, L3	-	-	-	-	These components are forming the matching network. The values depend on antenna impedance and required RF power
C4		16		pF	These values are taking pin capacitances into account and are valid for a crystal that requires 10 pF load capacitance.
C5		16		pF	
C6	70	100	130	nF	Place as close as possible to the pin
C7	470			nF	
C8	7	10	13	nF	
C9 ¹⁾		100		pF	

Application Circuit

Table 6-1 Application circuit component values (cont'd)

Unit	Min	Nom	Max	Unit	Comment
C10 ²⁾		218		pF	
C11		10		pF	Optional capacitors, only used if EMC performance, which depends on PCB layout, needs to be improved. Typically not needed if PPx pins are not connected. If used, place as close as possible to the pins.
C12		10		pF	
C13		10		pF	
C14		10		pF	
L4 ²⁾		7.1		mH	e.g. Coilcraft 4513TC-715XGL (Q=51)
R1 ²⁾		41		kOhm	
Q1		26.000		MHz	e.g. NX3225SA

- 1) A capacitor with a minimum impedance at RF center frequency should be chosen. The value for this optimal capacitor depends on capacitor material, size etc. Please refer to manufacturer documentation.
- 2) The Q-factor of this antenna circuit is 6.2. However, application may require another Q-factor. Hence the LF antenna circuit is understood as example.

7 Data Sheet Reference Board

The RF performance parameters have been verified with the data sheet reference board (DS Ref Board). The board can be ordered from Infineon. Order number for 315MHz variant is SP001330434, for 434MHz variant it is SP001330438.

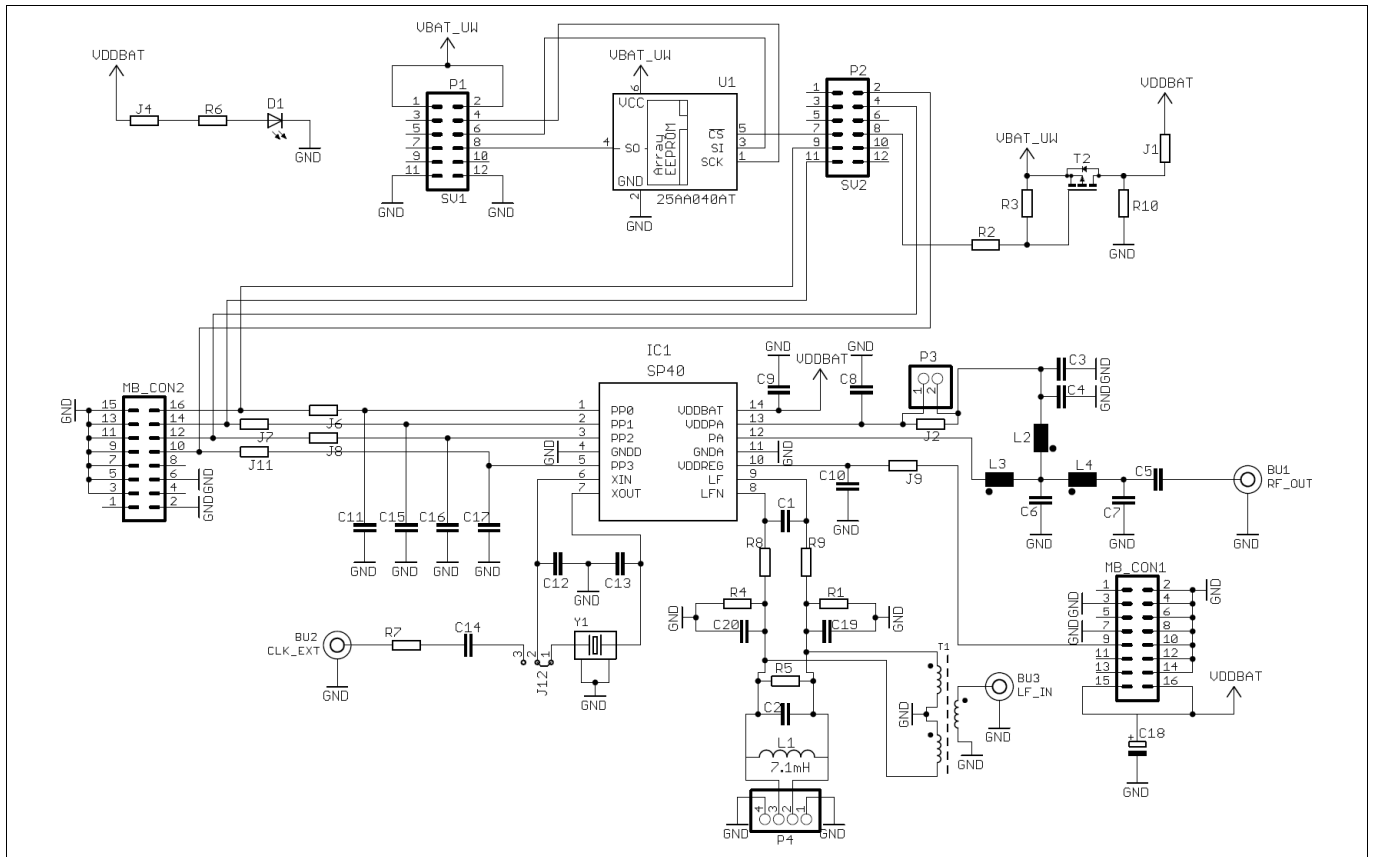

Figure 7-1 DS Ref Board schematic

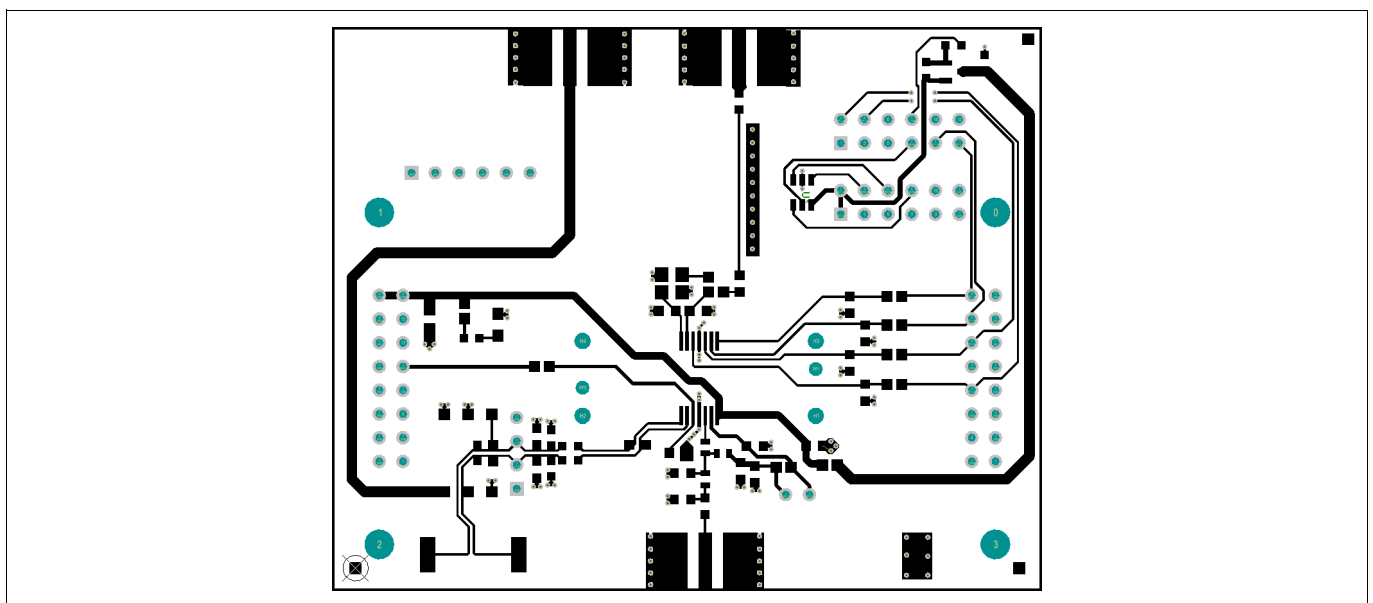

Figure 7-2 DS Ref Board top layer

Data Sheet Reference Board

Table 7-1 DS Ref Board component values

Unit	Value	Unit	Comment
C1, C2, C3, C1, C15, C16, C17, C19, C20			not placed
C4, C5, C6, C7			see Table 7-2
C8	10	nF	capacitor 0603, +/-5%
C9	1	μF	capacitor 0603, +/-5%
C10	100	nF	capacitor 0603, +/-5%
C12, C13	15	pF	capacitor 0603, +/-5%
C14	1	nF	capacitor 0603, +/-5%
C18	10	μF	tantal capacitor , 3.2 x 1.6 mm, +/-10%
R1, R4	100	Ohm	resistor 0603, +/-1%
R2, R7	1	kOhm	resistor 0603, +/-1%
R3	100	kOhm	resistor 0603, +/-1%
R5			not placed
R6	330	Ohm	resistor 0603, +/-1%
R8, R9	0	Ohm	resistor 0603
R10	10	kOhm	resistor 0603, +/-1%
T1	B78304-B1032-A3		Transformer EPCOS
T2	BSS315P		SOT23 P-CHANNEL MOSFET
L1			not placed
L2, L3, L4			see Table 7-2
U1	25AA040AT-I/OT		SOT23-6L, Mircochip EEPROM 4KB
BU1, BU2, BU3	RS526-5757		SMA connector
P1, P2	2x6		Molex pin header, Grid 2.54 mm
P3	1x2		Molex pin header, Grid 2.54 mm
P4	1x4		Molex pin header, Grid 2.54 mm
MB_CON1, MB_CON2	2x8		Pin header, Grid 2.54 m, not placed
GND	1x6		Molex pin header, Grid 2.54 mm
D1	yellow		chip LED 0805
Y1	NX3225SA-10P		crystal 26MHz
J1, J2, J4, J6, J7, J8, J11, J12	0R		resistor 0603
J9			not placed
IC1	SP40T		

Table 7-2 DS Ref Board matching network components

Component	434 MHz	315 MHz	Unit	Comment
C4	30	56	pF	capacitor 0603, +/-2%
C5	68	68	pF	capacitor 0603, +/-2%
C6	8.2	12	pF	capacitor 0603, +/-2%
C7	8.2	8.2	pF	capacitor 0603, +/-2%
L2	100	110	nH	Coilcraft 0603CS series, +/-2%
L3	56	100	nH	Coilcraft 0603CS series, +/-2%
L4	15	27	nH	Coilcraft 0603CS series, +/-2%

Package Information

8 Package Information

The SP40T package is a special development for the TPMS application. The name of the package is PG-DSOSP-14-82. The green package fulfills the solder condition for Pb-free assembly. The moisture sensitivity is MSL 1, the solder profile is according to JDEC-J-STD-020D, with a peak temperature of 250°C.

8.1 Package Outline

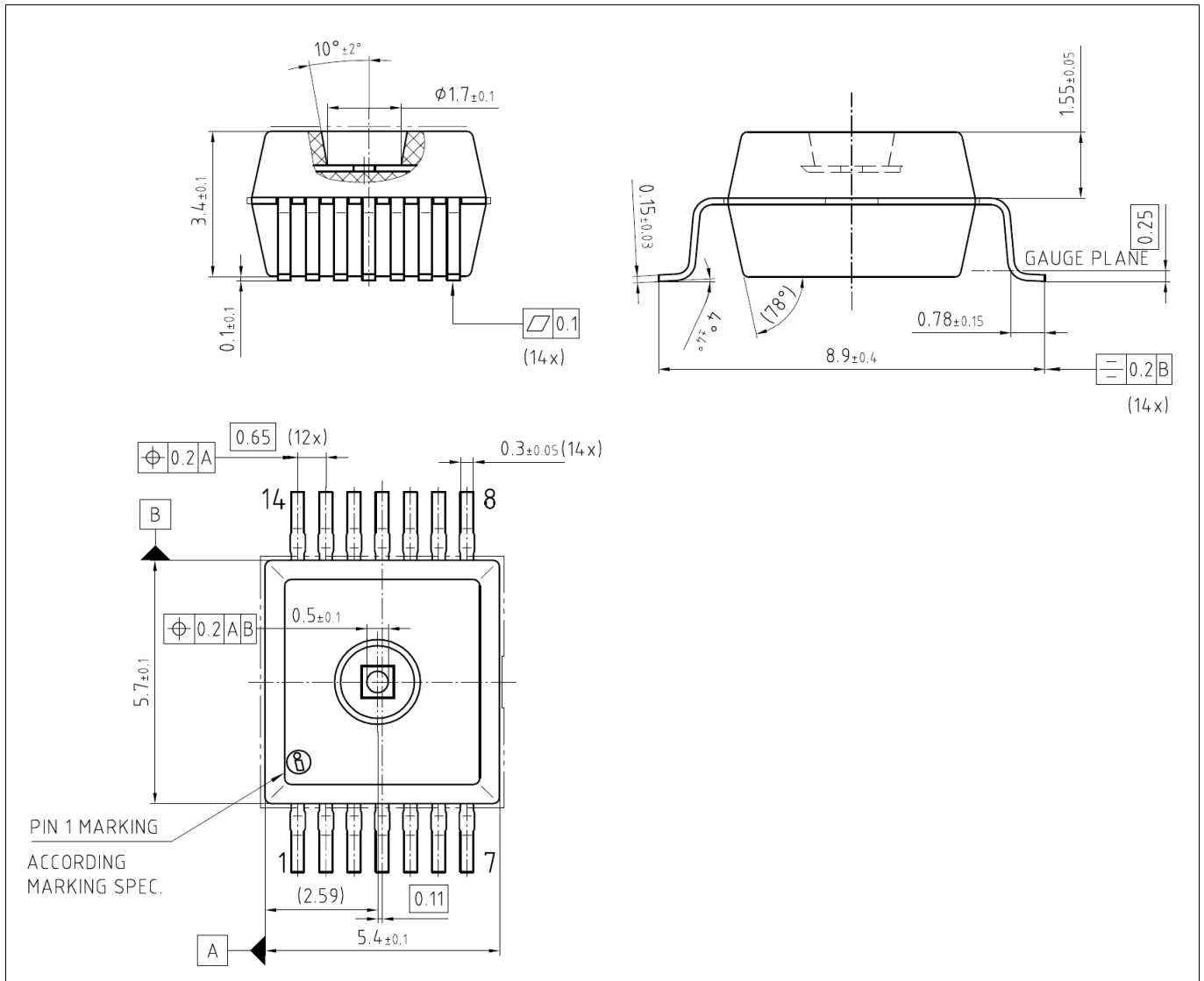

Figure 8-1 Package Outline

For further information on alternative packages, please visit our website:
<http://www.infineon.com/packages>.

Dimensions in mm

Package Information

8.2 Marking

The laser-marking consists of five fields:

- Pin 1 marking by Infineon logo
- Product code
- Date code (GYWW), where YY is the year and WW is the week)
- Lot code
- Six digit for optional marking

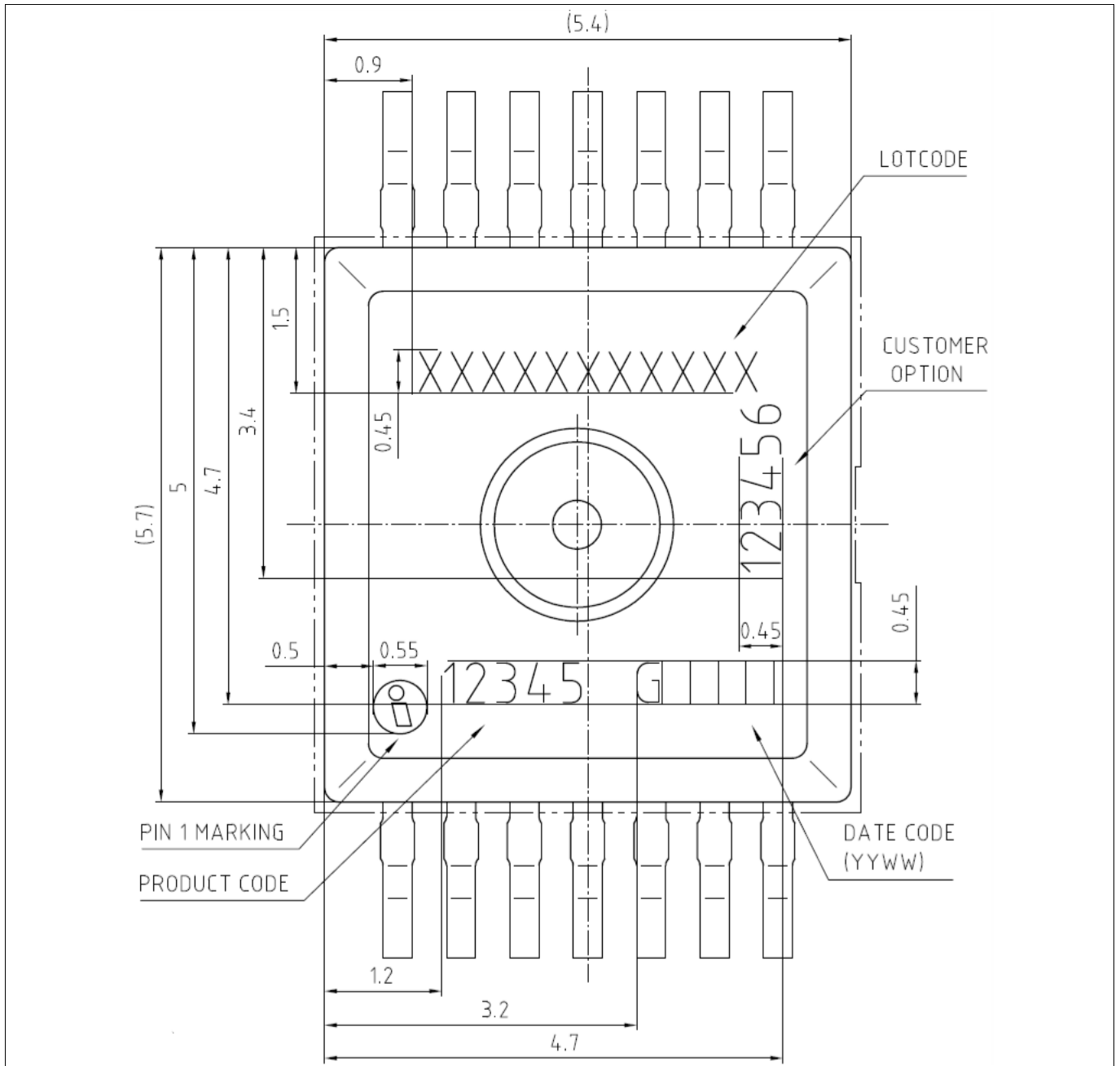

Figure 8-2 Marking information

Package Information

8.3 Package axis definition

Figure 8-3 shows the definition of the X-, Y- and Z-axis of the package. All axes mentioned in this document refer to this definition.

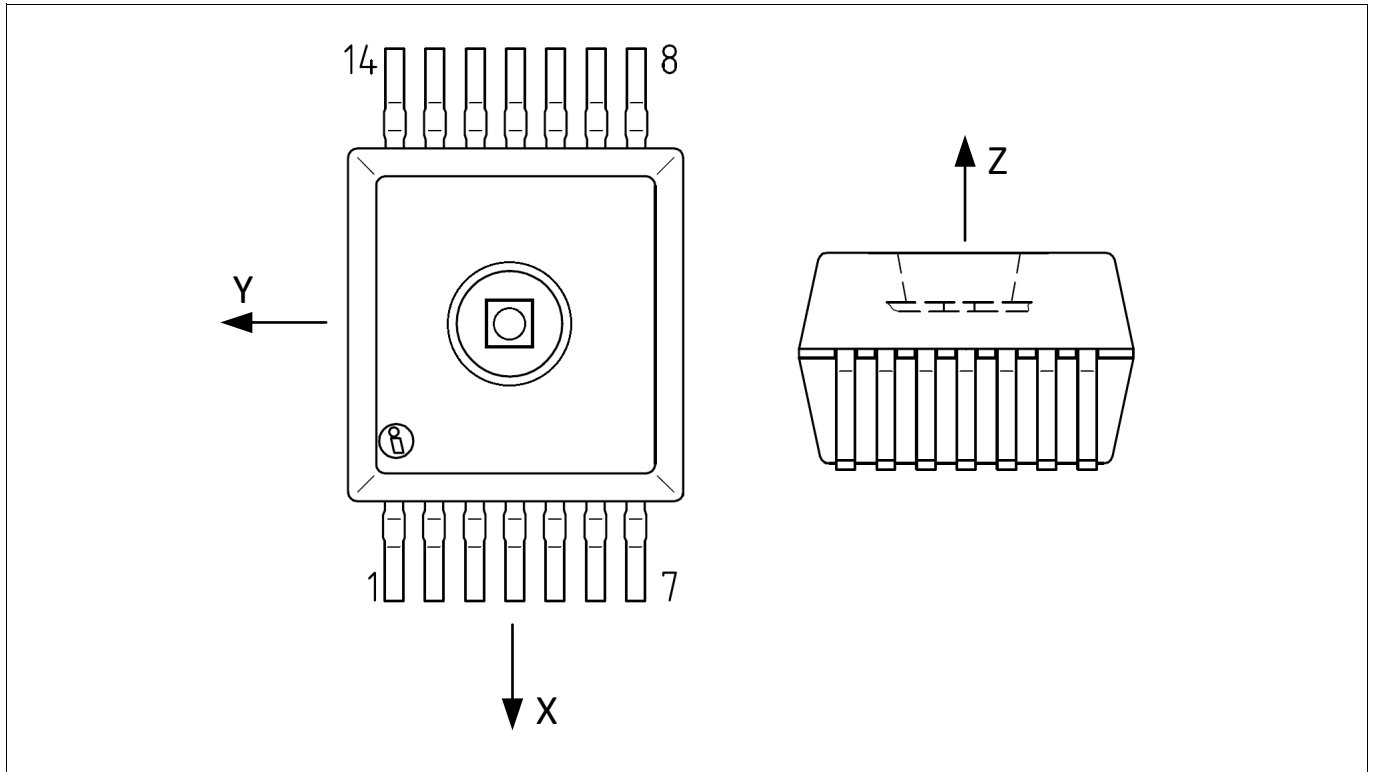

Figure 8-3 Package axis definition

Figure 8-4 shows the standard mounting position relative to the wheel. In this position the accelerometer output signal due to wheel rotation is positive for the positive acceleration measurement range.

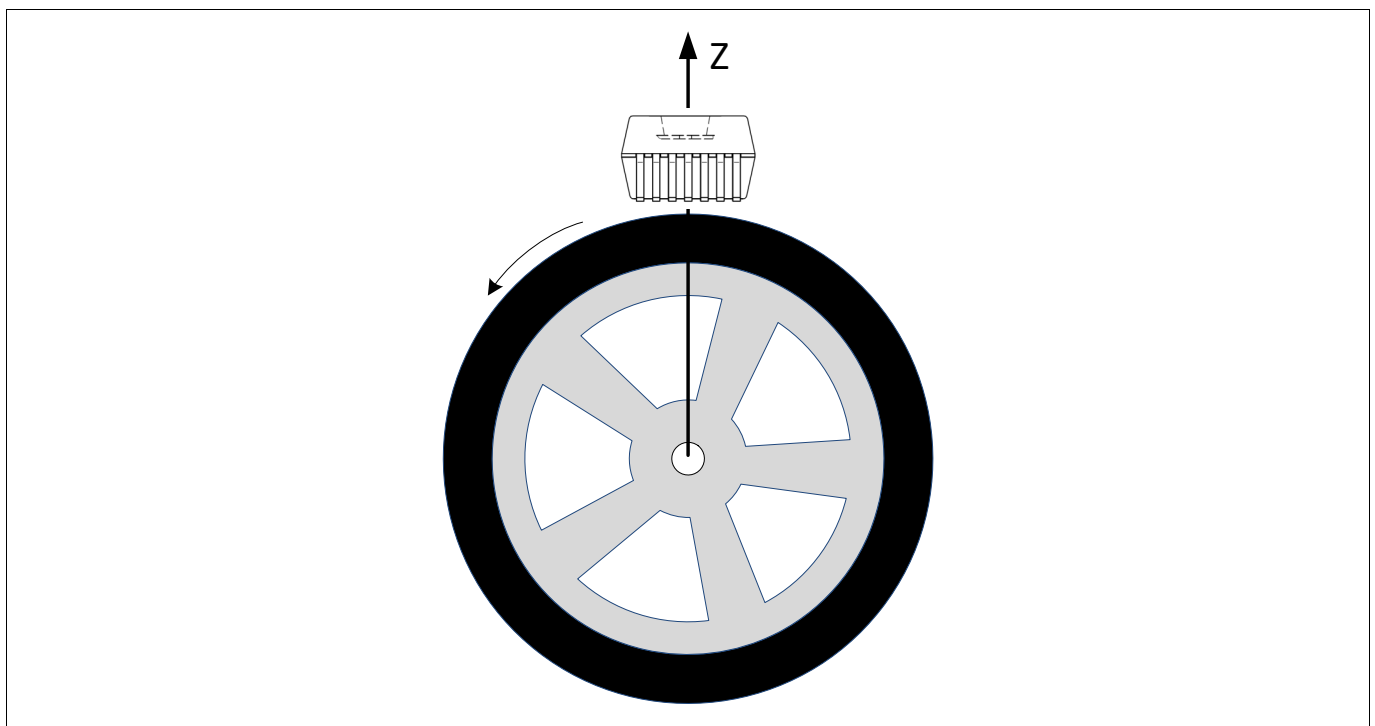

Figure 8-4 Standard mounting situation

References

- [1] SP40T ROM Library Guide
- [2] SP40T User Manual
- [3]
- [4]
- [5]
- [6]

Terminology

Bit Rate	Data bits transmitted per second
Baud-rate	Synonym with bit rate
Chip rate	A chip is the shortest rectangular pulse in a data stream. Chip rate is the reciprocal of the chip duration. For a Manchester coded data stream the chip rate is twice the bit rate.
Payload	The payload is the part of the transmission that is carrying information and may change from transmission to transmission. In contrast to payload, start / end of message does not carry information but is used for transmission recognition.
Frame	A frame is a sequence of start of message bits, payload bits and end of message bits.
Telegram	A telegram is a sequence of frames separated by interframe delays. In TPMS applications an RF telegram typically consists of a number of identical frames separated by interframe delays of different length. The purpose is to mitigate the effect of telegram collision.

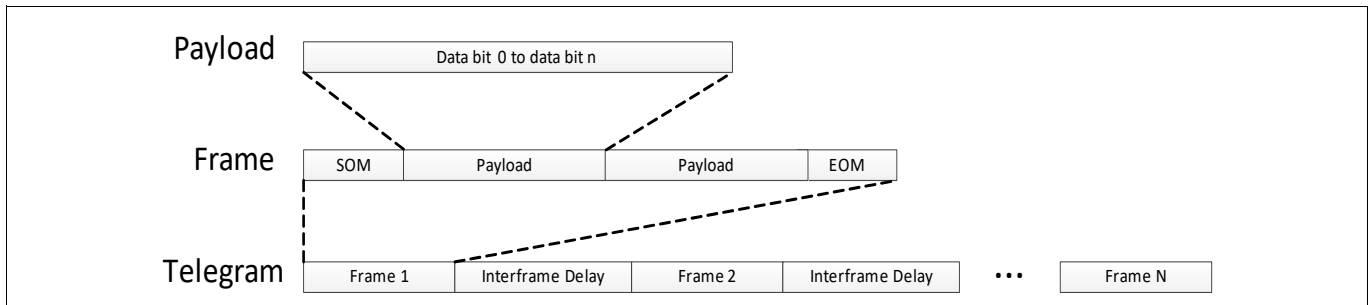

Figure 8-5 Definition of Payload, Frame and Telegram

Revision History

Page or Item	Subjects (major changes since previous revision)
Revision 1.1, 2020-05-14	
All pages	Non-confidential release

Trademarks of Infineon Technologies AG

AURIX™, C166™, CanPAK™, CIPOS™, CoolGaN™, CoolMOS™, CoolSET™, CoolSiC™, CORECONTROL™, CROSSAVE™, DAVE™, DI-POL™, DrBlade™, EasyPIM™, EconoBRIDGE™, EconoDUAL™, EconoPACK™, EconoPIM™, EiceDRIVER™, eupec™, FCOS™, HITFET™, HybridPACK™, Infineon™, ISOFACE™, IsoPACK™, i-Wafer™, MIPAQ™, ModSTACK™, my-d™, NovalithIC™, OmniTune™, OPTIGA™, OptiMOS™, ORIGA™, POWERCODE™, PRIMARION™, PrimePACK™, PrimeSTACK™, PROFET™, PRO-SIL™, RASIC™, REAL3™, ReverSave™, SatRIC™, SIEGET™, SiPMOS™, SmartLEWIS™, SOLID FLASH™, SPOC™, TEMPFET™, thinQ!™, TRENCHSTOP™, TriCore™.

Trademarks updated August 2015

Other Trademarks

All referenced product or service names and trademarks are the property of their respective owners.

Edition 2020-05-14

Published by

Infineon Technologies AG

81726 Munich, Germany

© 2020 Infineon Technologies AG.

All Rights Reserved.

Do you have a question about any aspect of this document?

Email: erratum@infineon.com

Document reference

IMPORTANT NOTICE

The information given in this document shall in no event be regarded as a guarantee of conditions or characteristics ("Beschaffungsgarantie").

With respect to any examples, hints or any typical values stated herein and/or any information regarding the application of the product, Infineon Technologies hereby disclaims any and all warranties and liabilities of any kind, including without limitation warranties of non-infringement of intellectual property rights of any third party.

In addition, any information given in this document is subject to customer's compliance with its obligations stated in this document and any applicable legal requirements, norms and standards concerning customer's products and any use of the product of Infineon Technologies in customer's applications.

The data contained in this document is exclusively intended for technically trained staff. It is the responsibility of customer's technical departments to evaluate the suitability of the product for the intended application and the completeness of the product information given in this document with respect to such application.

For further information on technology, delivery terms and conditions and prices, please contact the nearest Infineon Technologies Office (www.infineon.com).

WARNINGS

Due to technical requirements products may contain dangerous substances. For information on the types in question please contact your nearest Infineon Technologies office.



Except as otherwise explicitly approved by Infineon Technologies in a written document signed by authorized representatives of Infineon Technologies, Infineon Technologies' products may not be used in any applications where a failure of the product or any consequences of the use thereof can reasonably be expected to result in personal injury.

Looking for pricing, stock, or lifecycle information?

Click below to explore more details on WIN SOURCE:

-  [View SP4001511XTMA1 on WIN SOURCE](#)
-  [Infineon Technologies Information](#)

Optimize Your Supply Chain with WIN SOURCE Solutions

-  Global Sourcing Solution
-  Obsolete Management
-  Cost Control Management
-  Shortage Management
-  Alternative Solution
-  Excess Inventory Management