



**THE DATASHEET OF
IMC101TF048XUMA1**



IMC100 - iMOTION™ motor controller

High-performance turnkey motor control IC

IMC100

Features

- Motion Control Engine (MCE) as a ready-to-use control solution for variable speed drives
- Integrated script engine for application control customization
- Integrated drive and system protection features
- Field oriented control (FOC) for permanent magnet synchronous motor (PMSM)
- Flexible space vector PWM for sinusoidal voltage control
- Current sensing via single or leg shunt
- Sensorless operation
- Hall sensor operation using analog or digital Hall
- Integrated analog comparators for over-current protection
- Built-in temperature sensor
- Power factor correction (PFC) control (optional)
- Flexible control input options: UART, Frequency, duty cycle or analog signal
- Certified drive safety functions according to IEC/UL 60730-1 'Class B'

Potential applications

- Small and major home appliances
- Fans, Pumps, Compressors
- General purpose variable speed drives

Product validation

Qualified for industrial applications according to the relevant tests of JEDEC47/20/22.

Description

Description

iMOTION™ IMC100 is a family of highly integrated ICs for the control of variable speed drives. By integrating both the required hardware and software to perform control of a permanent magnet synchronous motor (PMSM) they provide the shortest time to market for any motor system at the lowest system and development cost.

The motor controller uses the Motion Control Engine (MCE) to create a ready-to-use solution to perform control of a permanent magnet synchronous motor (PMSM) providing the shortest time to market for any motor system at the lowest system and development cost. The integrated script engine allows to add application flexibility without interfering with the motor control algorithm.

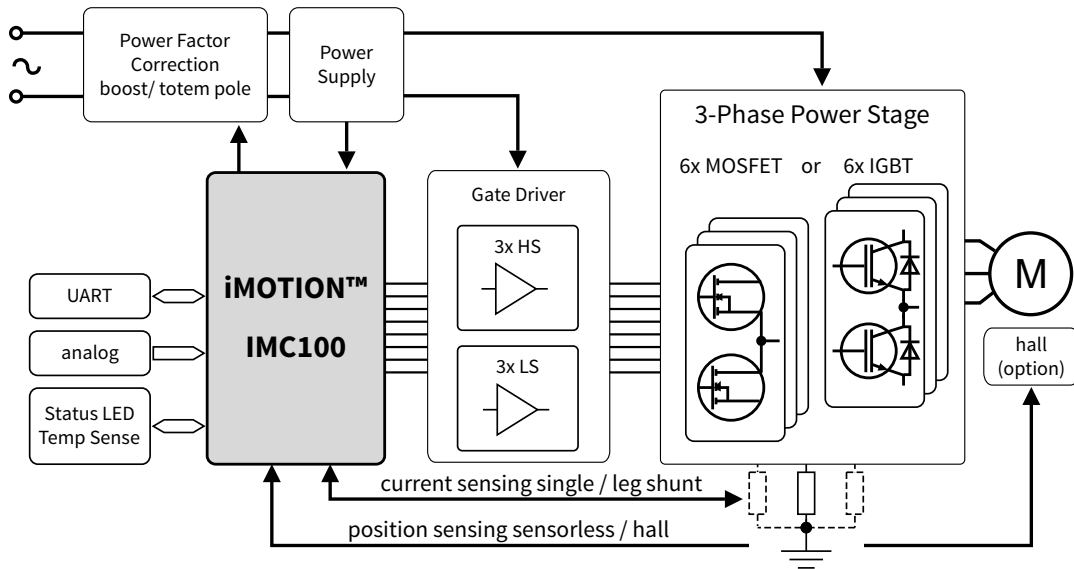

Ordering information

Product Type	Application	Package
IMC099T-T038	single motor, no scripting, no class B	TSSOP-38
IMC101T-T038	single motor	TSSOP-38
IMC101T-Q048		QFN-48
IMC101T-F048		LQFP-48
IMC101T-F064		LQFP-64
IMC102T-F048	single motor + PFC (boost, totem pole)	LQFP-48
IMC102T-F064		LQFP-64

Table of contents

	Features	1
	Potential applications	1
	Product validation	1
	Description	2
	Table of contents	3
1	Block diagram reference	5
2	Pin configuration	6
2.1	Pin types and pad structure	6
2.2	Pin configuration IMC099T/ IMC101T	7
2.3	Pin configuration drawing IMC099T/ IMC101T	10
2.4	Pin configuration IMC102T	14
2.5	Pin configuration drawing IMC102T	17
3	Functional description	19
3.1	Overview	19
3.2	Application schematic motor control single shunt	19
3.3	Application schematic motor control leg shunt	20
3.4	Application schematic motor control plus boost PFC	21
3.5	Application schematic motor control plus totem pole PFC	22
4	Electrical characteristics and parameters	23
4.1	General parameters	23
4.1.1	Parameter Interpretation	23
4.1.2	Absolute maximum ratings	23
4.1.3	Pin Reliability in Overload	24
4.1.4	Operating Conditions	25
4.2	DC characteristics	26
4.2.1	Input/Output Characteristics	26
4.2.2	Analog to Digital Converter (ADC)	28
4.2.3	Analog comparator characteristics	28
4.2.4	Power Supply Current Controller	29
4.2.5	Flash Memory Parameters	29
4.3	AC characteristics	30
4.3.1	Testing Waveforms	30
4.3.2	Power-Up and Supply Threshold Characteristics	30
4.3.3	On-Chip Oscillator Characteristics	32
4.4	Motor Control Parameters	33
4.4.1	PWM Characteristics	33
4.4.2	Current Sensing	33

Table of contents

4.4.3	Fault Timing	34
4.5	Power Factor Correction (PFC) parameters	35
4.5.1	Boost PFC characteristics	35
4.5.2	Totem Pole PFC characteristics	35
4.5.3	PFC Current Sensing	35
4.5.4	PFC Fault Timing	35
4.6	Device Interfaces	37
4.6.1	UART Interface	37
4.6.2	Analog Speed Input	38
4.6.3	Frequency Input	39
4.6.4	Duty Cycle Input	40
4.6.5	Over Temperature Input	41
4.6.6	Pulse Output	41
4.6.7	LED Output	41
5	Device and package specifications	42
5.1	Quality declaration	42
5.2	SBSL and Chip-IDs	42
5.3	Thermal Characteristics	43
5.4	Package Outlines	44
5.4.1	Package Outline PG-TSSOP-38-9	44
5.4.2	Package Outline PG-VQFN-48-73	45
5.4.3	Package Outline PG-LQFP-48-10	46
5.4.4	Package Outline PG-LQFP-64-26	47
5.5	Part marking information	48
	Revision history	49
	Disclaimer	50

1 Block diagram reference

1 Block diagram reference

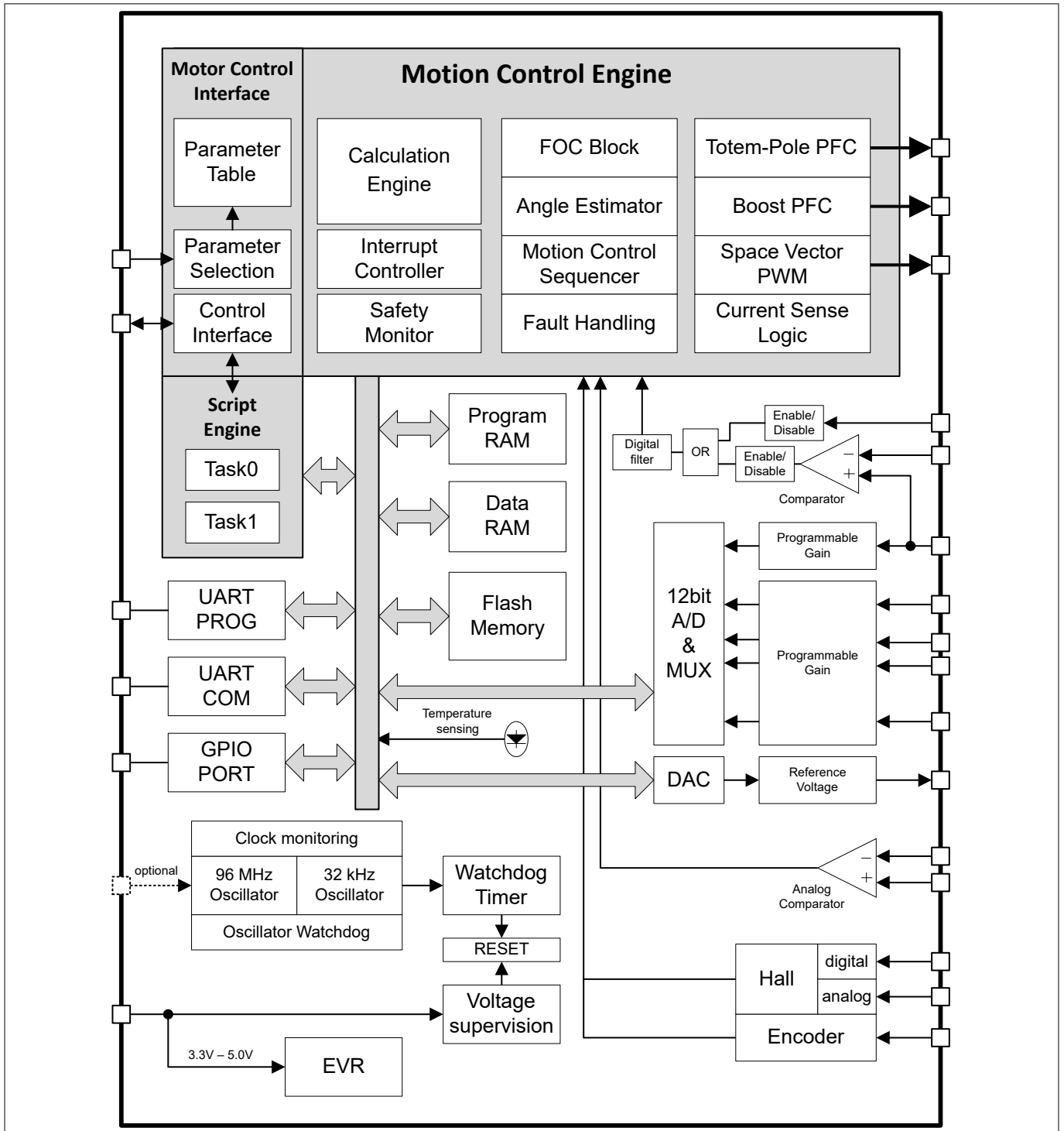

Figure 1 Block diagram reference

2 Pin configuration

2 Pin configuration

2.1 Pin types and pad structure

The pin type is specified as follows:

- P - power
- I - digital input
- O - digital output
- IO – digital input or output
- AIN - analog input
- AO - analog output

Figure 2 shows the pad structure and pin function control configuration for the input and output pins of the controller integrated.

The pin function, type and pull up/pull down circuit configuration are all controlled by the Motion Control Engine. Digital input, output or analog input signals that are not assigned to MCE functions can be assigned to the script engine.

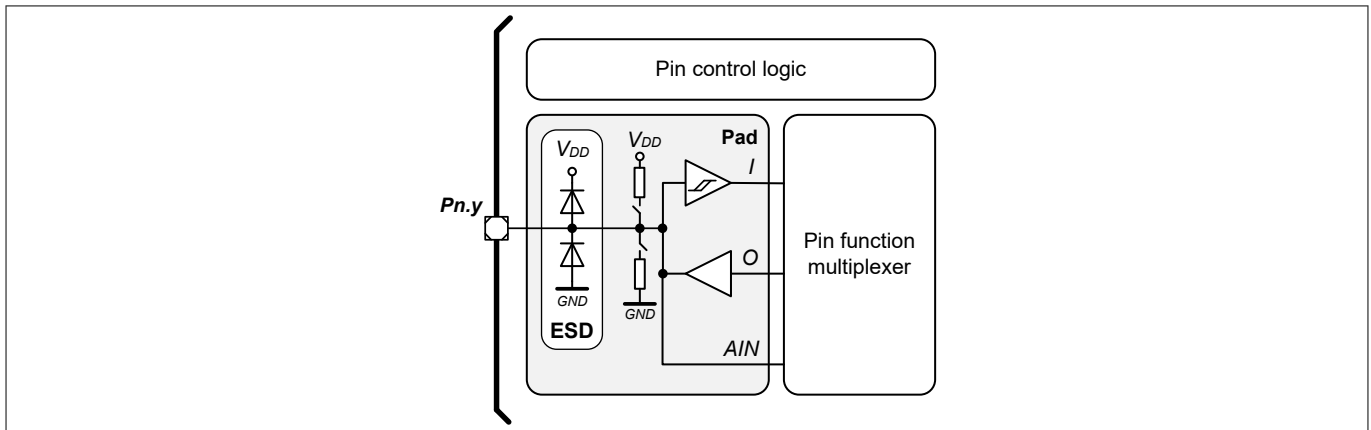

Figure 2 Pin Pad and Function Configuration

The pin function table given below refers to the standard configuration. The pin control or interface functions are defined by the version of software downloaded to the device and may change. Some of the input pins can be configured to have pull up or pull down resistor and some output pins can be configured to push-pull or open drain. This is described in the respective software reference manual.

Pins can serve multiple functions and have to be configured accordingly. Please also refer to the respective pin configuration drawings in this data sheet and the description in the MCE software reference manual.

Pins that do not have any signal assigned are reserved for future use. These pins should be left unconnected and neither be connected to ground nor to the positive supply.

Note: All required reference voltages are generated by an internal DAC, therefore the AO pins like IREF, REFU, REFV, and REFW only require a blocking capacitor.

2 Pin configuration

2.2 Pin configuration IMC099T/ IMC101T

Note: IMC099T-T038 does not support scripting. Therefore the scripting pins given below for the TSSOP-38 package only apply to the IMC101T-T038.

Table 1 Pin list

Signal	Type	LQFP-64	VQFN-48	LQFP-48	TSSOP-38	Description
Supply						
VDD	Power	2, 24, 25, 35, 50	18, 19, 27, 38	21, 28, 38	10, 26	Supply Voltage
VSS	Power	1, 23, 49	17, 37	20, 37	9, 25	Ground
Motor control						
PWMUL	O	29	21	22	11	PWM output phase U low side
PWMUH	O	30	22	23	12	PWM output phase U high side
PWMVL	O	31	23	24	13	PWM output phase V low side
PWMVH	O	32	24	25	14	PWM output phase V high side
PWMWL	O	33	25	26	15	PWM output phase W low side
PWMWH	O	34	26	27	16	PWM output phase W high side
GK	I	36	28	29	18	Motor gate kill input
VDC	AIN	14	8	11	2	DC bus sensing input
ISS/IU	AIN	18	12	15	6	Current sense input single shunt / phase U
IV	AIN	15	9	12	3	Current sense input phase V / analog input
IW	AIN	11	5	8	37	Current sense input phase W / analog input
REFU	AIN	17	11	14	5	Itrip phase U reference / analog input
REFV	AIN	16	10	13	4	Itrip phase V reference / analog input
REFW	AIN	10	4	7	36	Itrip phase W reference / analog input
Hall sensor inputs						
AHALL1+	AIN	10	4	7	36	Analog hall 1 positive input
AHALL1-	AIN	11	5	8	37	Analog hall 1 negative input
AHALL2+	AIN	16	10	13	4	Analog hall 2 positive input
AHALL2-	AIN	15	9	12	3	Analog hall 2 negative input
HALL1	I	26	44	47	1	Digital hall input 1
HALL2	I	27	45	48	38	Digital hall input 2
HALL3	I	28	46	1	8	Digital hall input 3
Interface						
DIR	I	52	40	40	28	Direction input
DUTYFREQ ¹⁾	I	55	43	43	31	Duty/Frequency input

(table continues...)

2 Pin configuration

Table 1 (continued) Pin list

Signal	Type	LQFP-64	VQFN-48	LQFP-48	TSSOP-38	Description
VSP	AIN	9	3	6	35	Analog speed reference input
PGOUT	O	42	30	34	21	Pulse output
PARAM	AIN	20	14	17	8	Parameter table selection, analog
PAR0	I	3	33	2	22	Parameter page select 0
PAR1	I	4	34	3	23	Parameter page select 1
PAR2	I	5	35	4	24	Parameter page select 2
PAR3	I	6	36	5	27	Parameter page select 3
NTC	AIN	13	7	10	7	External thermistor input
LED	O	41	29	35	17	Status LED

Communication

RX0	I	57	45	45	33	Serial port 0, device programming, receive input
TX0	O	58	46	46	34	Serial port 0, device programming, transmit output
RX1	I	63	47	30	20	Serial port 1, user communication, receive input
TX1	O	64	48	31	19	Serial port 1, user communication, transmit output

Scripting

AIN0	AIN	9	3	6	35	Analog input 0
AIN1	AIN	10	4	7	36	Analog input 1
AIN2	AIN	11	5	8	37	Analog input 2
AIN3	AIN	12	6	9	38	Analog input 3
AIN4	AIN	13	7	10	1	Analog input 4
AIN7	AIN	16	10	13	4	Analog input 7
AIN8	AIN	17	11	14	5	Analog input 8
AIN10	AIN	19	13	16	7	Analog input 5
AIN11	AIN	20	14	17	8	Analog input 6
GPIO2	IO	3	33	2	22	Digital input/output 2
GPIO3	IO	4	34	3	23	Digital input/output 3
GPIO4	IO	5	35	4	24	Digital input/output 4
GPIO5	IO	6	36	5	27	Digital input/output 5
GPIO6	IO	52	40	40	28	Digital input/output 6
GPIO7	IO	7	1	1	29	Digital input/output 7
GPIO8	IO	8	2	32	30	Digital input/output 8
GPIO9	IO	26	20	33	32	Digital input/output 9

(table continues...)

¹ Function not available when used with Hall sensor mode (i.e. AHALL1+/- and AHALL2+/- or HALL1/2/3 are used)

2 Pin configuration

Table 1 (continued) Pin list

Signal	Type	LQFP-64	VQFN-48	LQFP-48	TSSOP-38	Description
GPIO10	IO	27	31	36		Digital input/output 10
GPIO11	IO	28	32	39		Digital input/output 11
GPIO12	IO	37	39	41		Digital input/output 12
GPIO13	IO	38	41	42		Digital input/output 13
GPIO14	IO	39	42	44		Digital input/output 14
GPIO15	IO	40	44	47		Digital input/output 15
GPIO16	IO	43	15	48		Digital input/output 16
GPIO17	IO	44	16	18		Digital input/output 17
GPIO18	IO	45		19		Digital input/output 18
GPIO19	IO	46				Digital input/output 19
GPIO20	IO	47				Digital input/output 20
GPIO21	IO	48				Digital input/output 21
GPIO22	IO	51				Digital input/output 22
GPIO23	IO	53				Digital input/output 23
GPIO24	IO	54				Digital input/output 24
GPIO25	IO	56				Digital input/output 25
GPIO26	IO	59				Digital input/output 26
GPIO27	IO	60				Digital input/output 27
GPIO28	IO	61				Digital input/output 28
GPIO29	IO	62				Digital input/output 29
TRIN0	I	52	40	40	28	TRIAC control input 0
TRIN1	I	44	32	33	20	TRIAC control input 1
TROUT0	O	8	14	17	8	TRIAC control output 0
TROUT1	O	62	-	-	-	TRIAC control output 1
SCL	O	51	39	31	27	I2C interface serial clock
SDA	IO	48	36	30	24	I2C interface serial data
IR0	I	57	45	45	33	IR interface 0
IR1	I	63	47	30	20	IR interface 1
IR2	I	9	3	6	35	IR interface 2

2 Pin configuration

2.3 Pin configuration drawing IMC099T/ IMC101T

The following drawings give the position of the functional pins for the available packages.

Note: IMC099T-T038 does not support scripting. Therefore the scripting pins given in the drawing below for the TSSOP-38 package only apply to the IMC101T-T038.

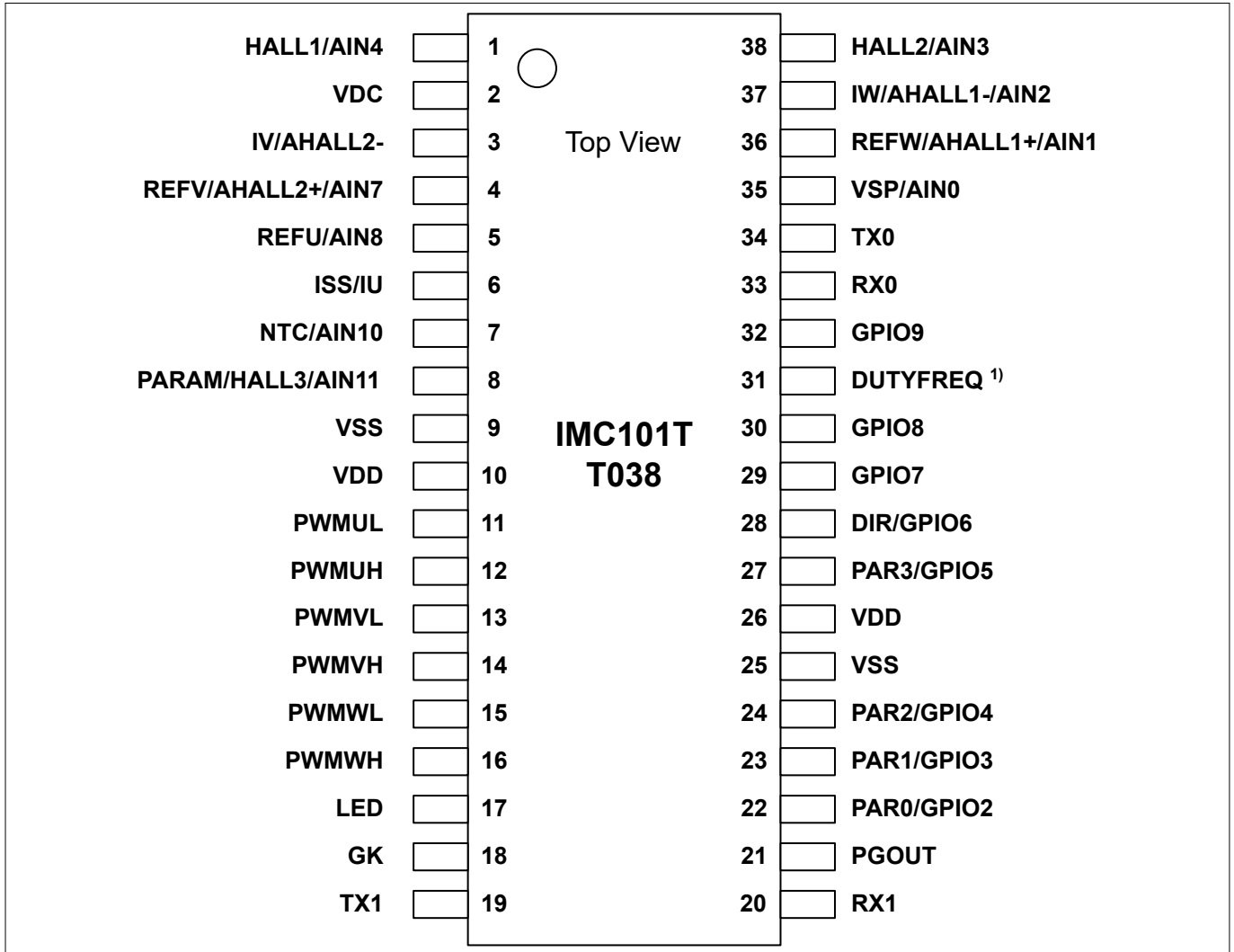

Figure 3 IMC099T-T038, IMC101T-T038

Pins that do not have any signal assigned are reserved for future use. These pins should be left unconnected and neither be connected to ground nor to the positive supply.

2 Pin configuration

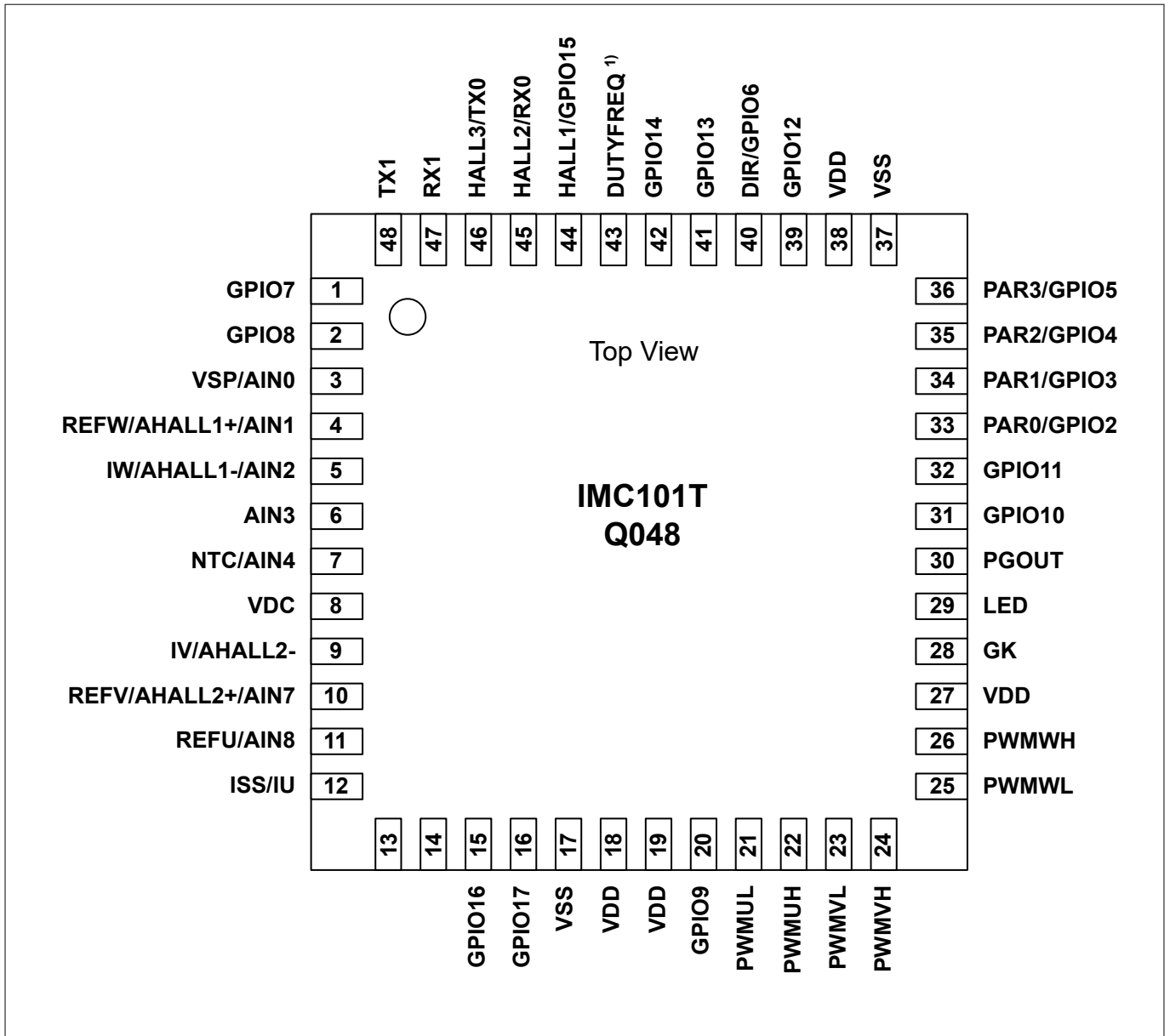

Figure 4 IMC101T-Q048

Pins that do not have any signal assigned are reserved for future use. These pins should be left unconnected and neither be connected to ground nor to the positive supply.

2 Pin configuration

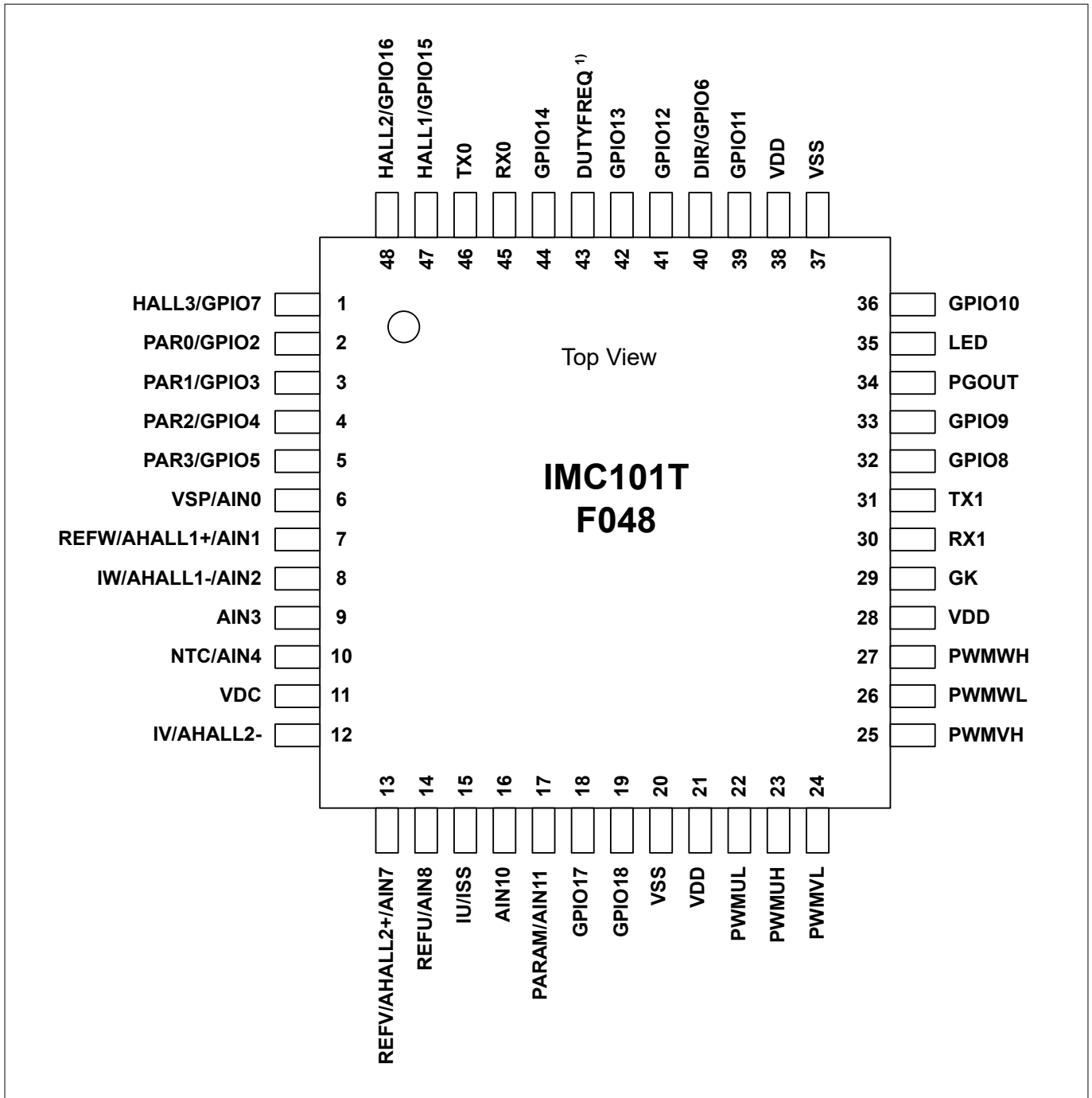

Figure 5 IMC101T-F048

Pins that do not have any signal assigned are reserved for future use. These pins should be left unconnected and neither be connected to ground nor to the positive supply.

2 Pin configuration

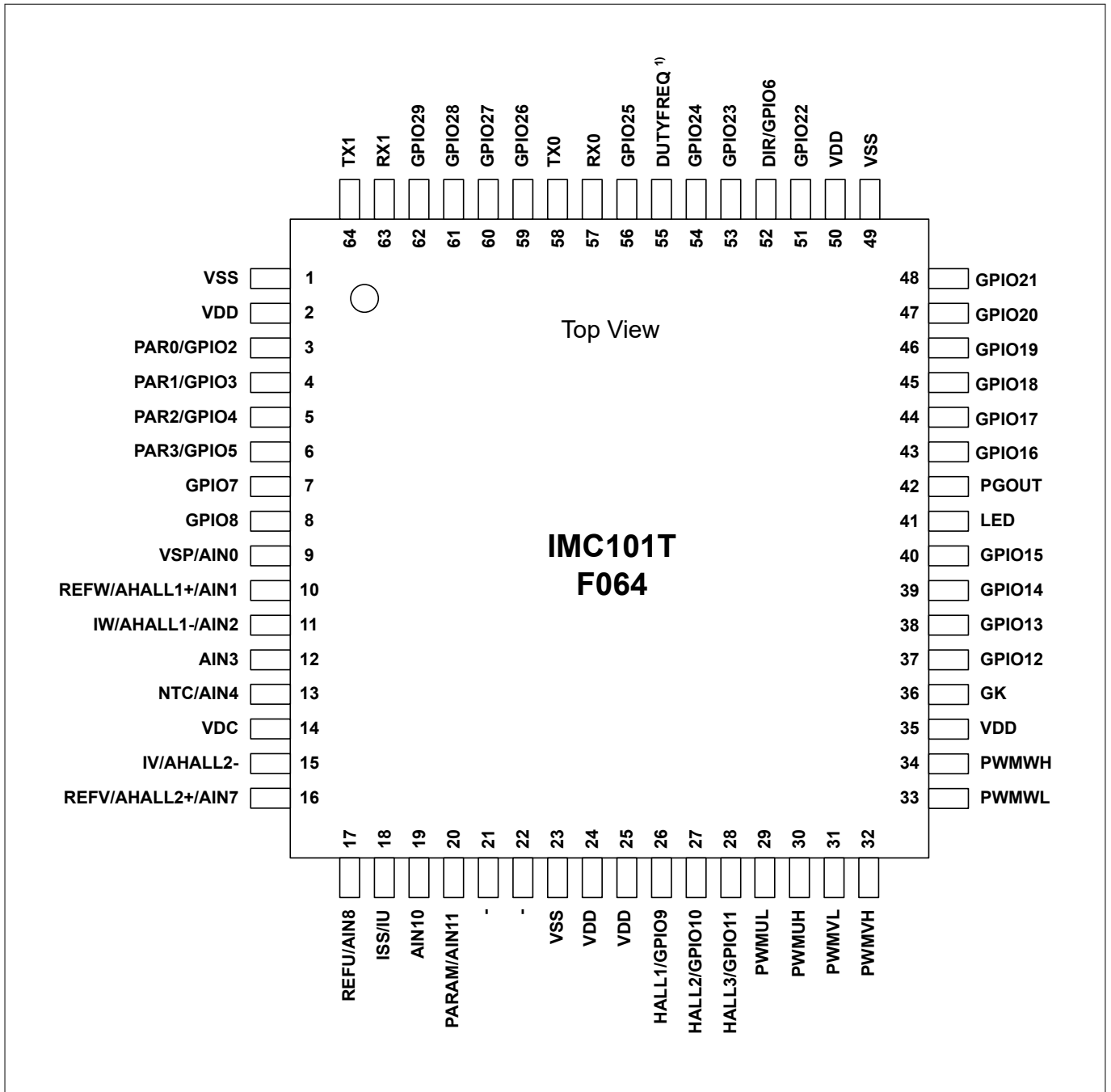

Figure 6 IMC101T-F064

Pins that do not have any signal assigned are reserved for future use. These pins should be left unconnected and neither be connected to ground nor to the positive supply.

2 Pin configuration

2.4 Pin configuration IMC102T

Table 2 Pin list Motion Control Engine

Signal	Type	LQFP-64	LQFP-48	Description
Supply				
VDD	Power	2, 24, 25, 35, 50	21, 28, 38	Supply Voltage
VSS	Power	1, 23, 49	20, 37	Ground
Motor control				
PWMUL	O	29	22	PWM output phase U low side
PWMUH	O	30	23	PWM output phase U high side
PWMVL	O	31	24	PWM output phase V low side
PWMVH	O	32	25	PWM output phase V high side
PWMWL	O	33	26	PWM output phase W low side
PWMWH	O	34	27	PWM output phase W high side
GK	I	36	29	Motor gate kill input
VDC	AIN	14	11	DC bus sensing input
ISS/IU	AIN	18	15	Current sense input single shunt / phase U
IV	AIN	15	12	Current sense input phase V / analog input
IW	AIN	11	8	Current sense input phase W / analog input
REFU	AIN	17	14	Itrip phase U reference / analog input
REFV	AIN	16	13	Itrip phase V reference / analog input
REFW	AIN	10	7	Itrip phase W reference / analog input
Hall sensor inputs				
AHALL1+	AIN	10	7	Analog hall 1 positive input
AHALL1-	AIN	11	8	Analog hall 1 negative input
AHALL2+	AIN	16	13	Analog hall 2 positive input
AHALL2-	AIN	15	12	Analog hall 2 negative input
HALL1	I	26	47	Digital hall input 1
HALL2	I	27	48	Digital hall input 2
HALL3	I	28	1	Digital hall input 3
Power factor correction				
PFCG0	O	44	33	PFC gate drive 0
PFCG1	O	43	32	PFC gate drive 1 (totem pole only - high side switch)
PFCI	AIN	12	9	PFC current sensing
PFCREF	AIN	21	18	Itrip PFC reference input
PFCITRIP	AIN	22	19	Itrip PFC input
VAC1	AIN	20	17	VAC sense input line 1

(table continues...)

2 Pin configuration

Table 2 (continued) Pin list Motion Control Engine

Signal	Type	LQFP-64	LQFP-48	Description
VAC2	AIN	19	16	VAC sense input line 2
Interface				
DIR	I	52	40	Direction input
DUTYFREQ ²⁾	I	55	43	Duty/Frequency input
VSP	AIN	9	6	Analog speed reference input
PGOUT	O	42	34	Pulse output
PAR0	I	3	2	Parameter page select 0
PAR1	I	4	3	Parameter page select 1
PAR2	I	5	4	Parameter page select 2
PAR3	I	6	5	Parameter page select 3
NTC	AIN	13	10	External thermistor input
LED	O	41	35	Status LED
Communication				
RX0	I	57	45	Serial port 0, device programming, receive input
TX0	O	58	46	Serial port 0, device programming, transmit output
RX1	I	63	30	Serial port 1, user communication, receive input
TX1	O	64	31	Serial port 1, user communication, transmit output
Scripting				
AIN0	AIN	9	6	Analog input 0
AIN1	AIN	10	7	Analog input 1
AIN2	AIN	11	8	Analog input 2
AIN4	AIN	13	10	Analog input 4
AIN7	AIN	16	13	Analog input 7
AIN8	AIN	17	14	Analog input 8
GPIO2	IO	3	2	Digital input/output 2
GPIO3	IO	4	3	Digital input/output 3
GPIO4	IO	5	4	Digital input/output 4
GPIO5	IO	6	5	Digital input/output 5
GPIO6	IO	52	-	Digital input/output 6
GPIO7	IO	7	1	Digital input/output 7
GPIO8	IO	8	-	Digital input/output 8
GPIO9	IO	26	-	Digital input/output 9
GPIO10	IO	27	36	Digital input/output 10
GPIO11	IO	28	39	Digital input/output 11
GPIO12	IO	37	41	Digital input/output 12

(table continues...)

² Function not available when used with Hall sensor mode (i.e. AHALL1+/- and AHALL2+/- or HALL1/2/3 are used)

2 Pin configuration

Table 2 (continued) Pin list Motion Control Engine

Signal	Type	LQFP-64	LQFP-48	Description
GPIO13	IO	38	42	Digital input/output 13
GPIO14	IO	39	44	Digital input/output 14
GPIO15	IO	40	47	Digital input/output 15
GPIO18	IO	45	48	Digital input/output 18
GPIO19	IO	46		Digital input/output 19
GPIO20	IO	47		Digital input/output 20
GPIO21	IO	48		Digital input/output 21
GPIO22	IO	51		Digital input/output 22
GPIO23	IO	53		Digital input/output 23
GPIO24	IO	54		Digital input/output 24
GPIO25	IO	56		Digital input/output 25
GPIO26	IO	59		Digital input/output 26
GPIO27	IO	60		Digital input/output 27
GPIO28	IO	61		Digital input/output 28
GPIO29	IO	62		Digital input/output 29
TRIN0	I	52	-	TRIAC control input 0
TROUT0	O	8	-	TRIAC control output 0
TROUT1	O	62	-	TRIAC control output 1
SCL	O	51	31	I2C interface serial clock
SDA	IO	48	30	I2C interface serial data
IR0	I	57	45	IR interface 0
IR1	I	63	30	IR interface 1
IR2	I	9	6	IR interface 2

2 Pin configuration

2.5 Pin configuration drawing IMC102T

The following drawings give the position of the functional pins for the available packages.

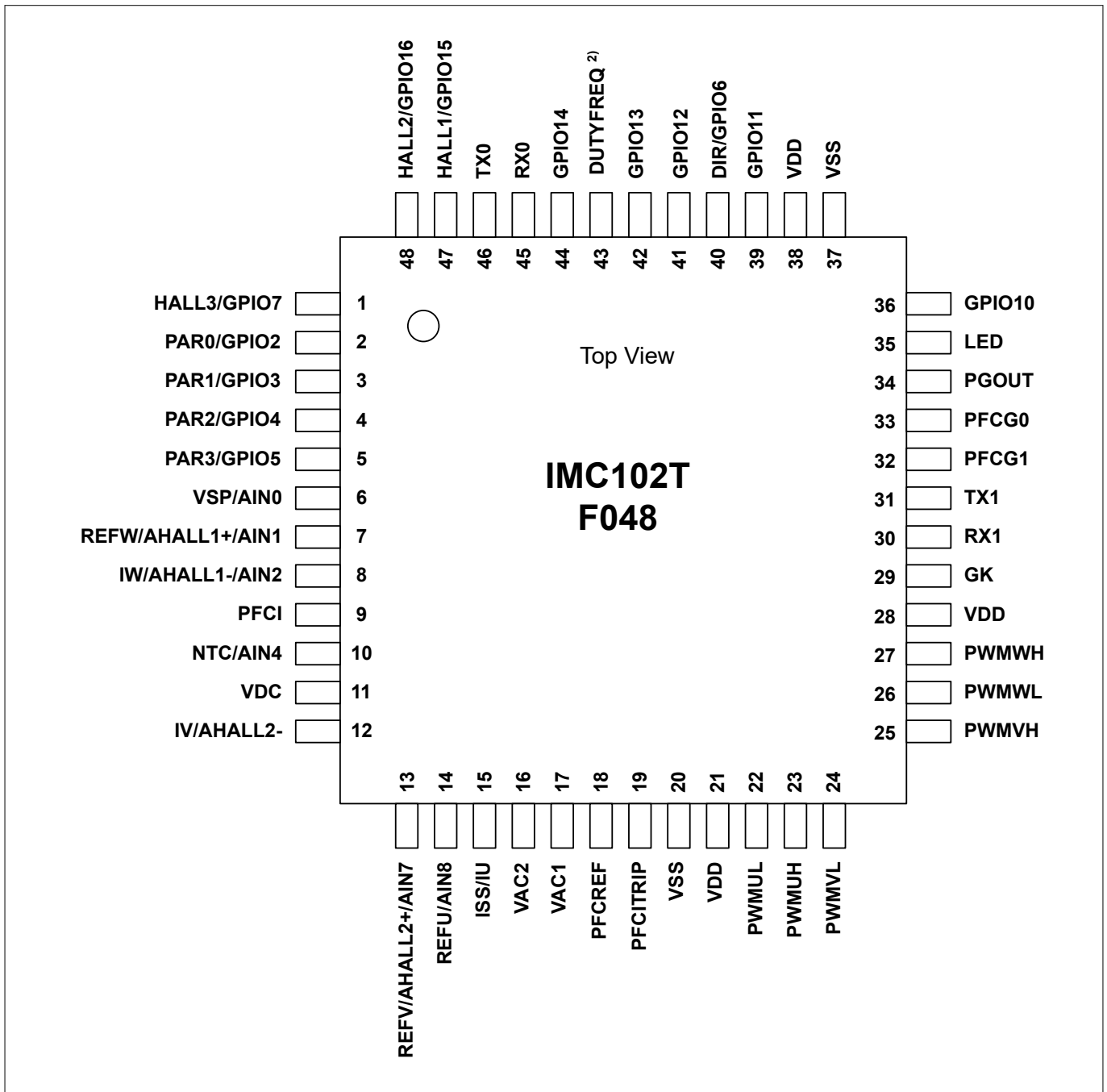

Figure 7 IMC102T-F048

Pins that do not have any signal assigned are reserved for future use. These pins should be left unconnected and neither be connected to ground nor to the positive supply.

2 Pin configuration

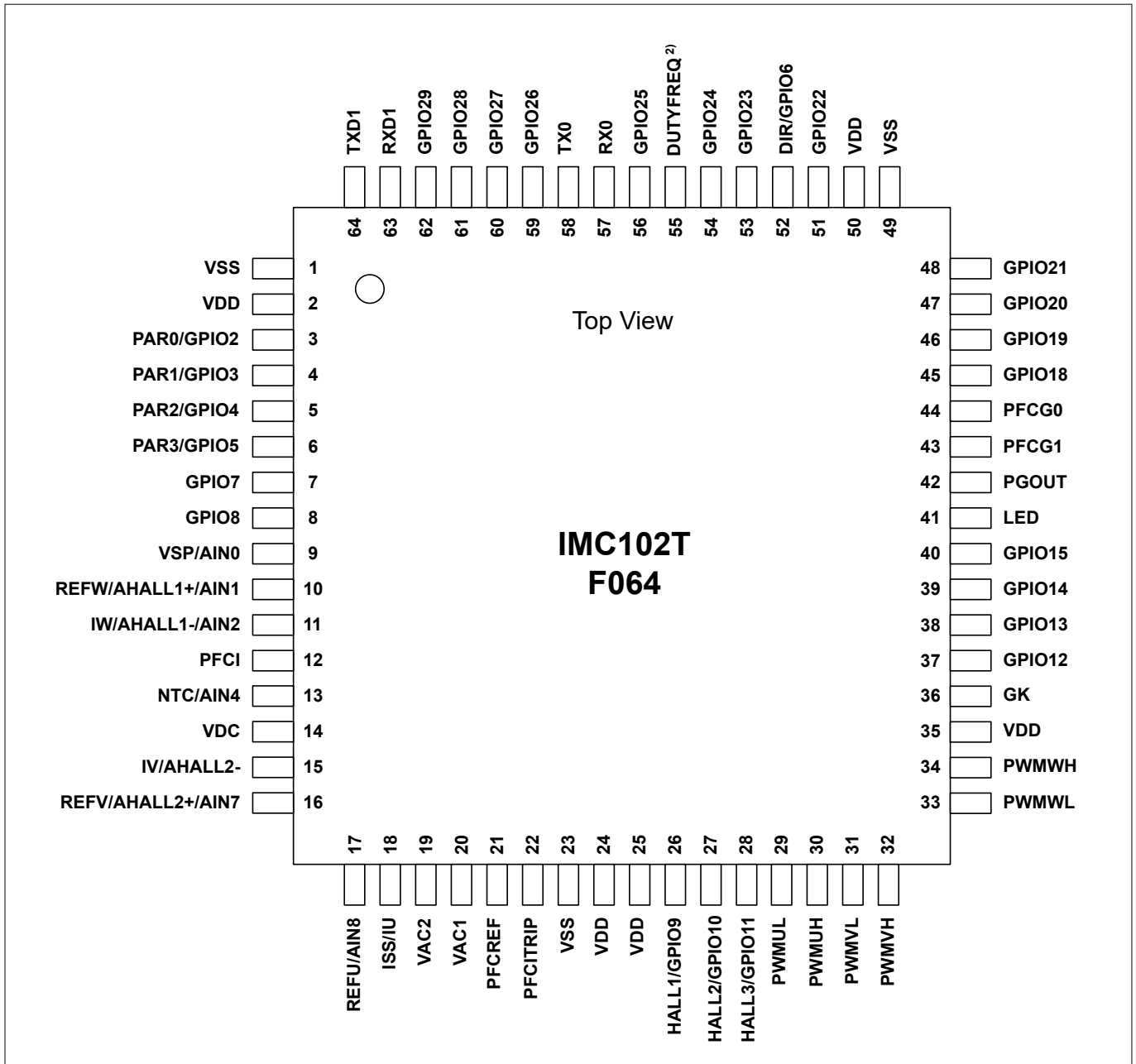

Figure 8 IMC102T-F064

Pins that do not have any signal assigned are reserved for future use. These pins should be left unconnected and neither be connected to ground nor to the positive supply.

3 Functional description

3 Functional description

3.1 Overview

iMOTION™ IMC100 is a series of highly integrated ICs for the control of a Permanent Magnet Synchronous Motor (PMSM). IMC101T devices provide control of a single motor and the IMC102 devices control the motor and additionally a boost or totem pole power factor correction (PFC).

The IMC100 series takes advantage of a new hardware platform that is based on a comprehensive set of innovative analog and motor control peripherals. The high level of integration both in terms of hardware modules and software algorithms results in a minimum number of external components required for the implementation of the inverter control.

3.2 Application schematic motor control single shunt

Figure 9 gives the schematic diagram for a motor control system using the IMC101T in sensorless operation and single shunt current sensing mode. As an option analog hall elements or digital hall switches can be used to improve low speed performance.

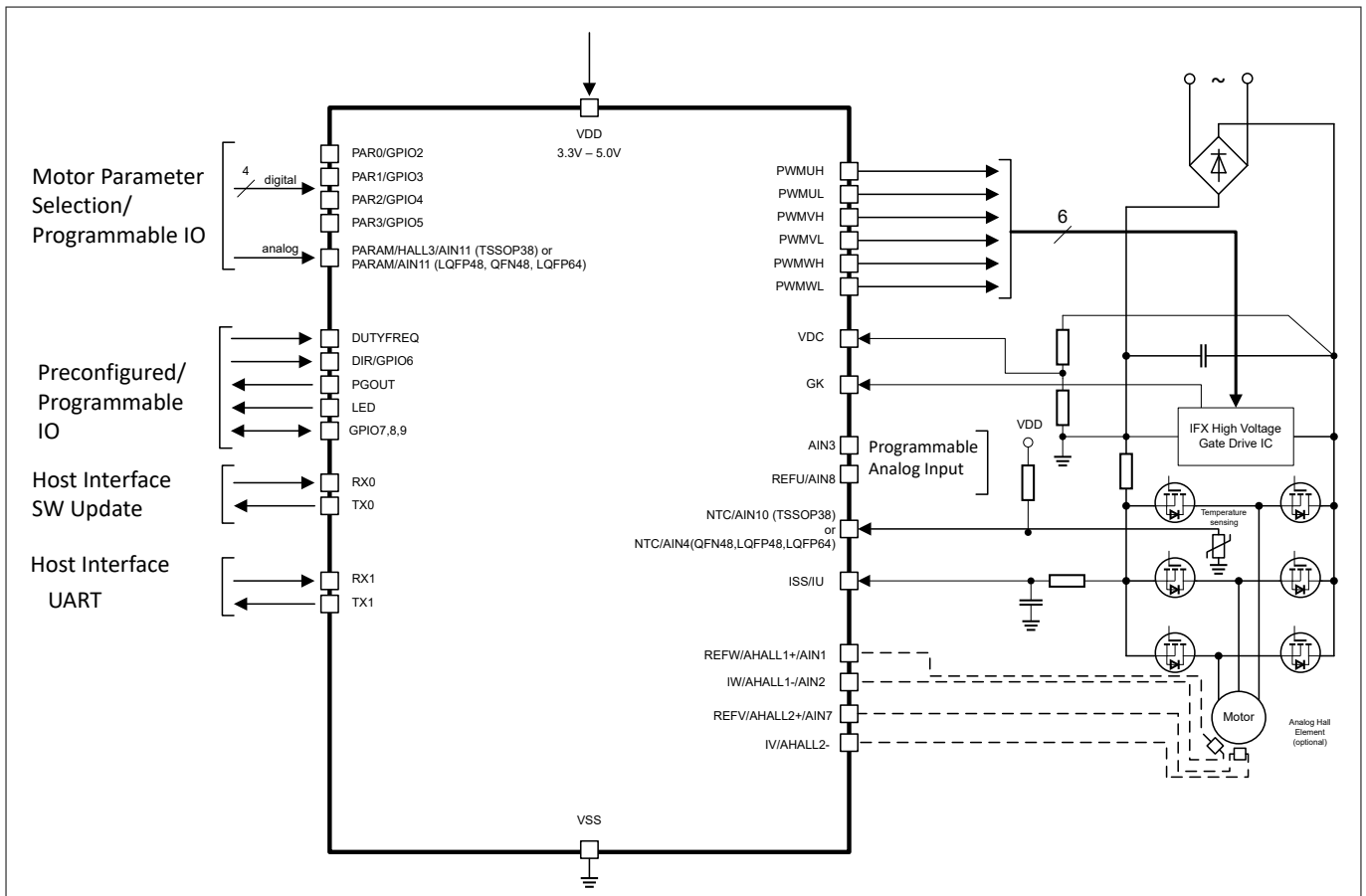

Figure 9 IMC101T in single shunt configuration

3 Functional description

3.3 Application schematic motor control leg shunt

Figure 10 gives the schematic diagram for a motor control system using the IMC101T in sensorless operation and leg shunt current sensing mode. An NTC can be used for temperature sensing at the power stage.

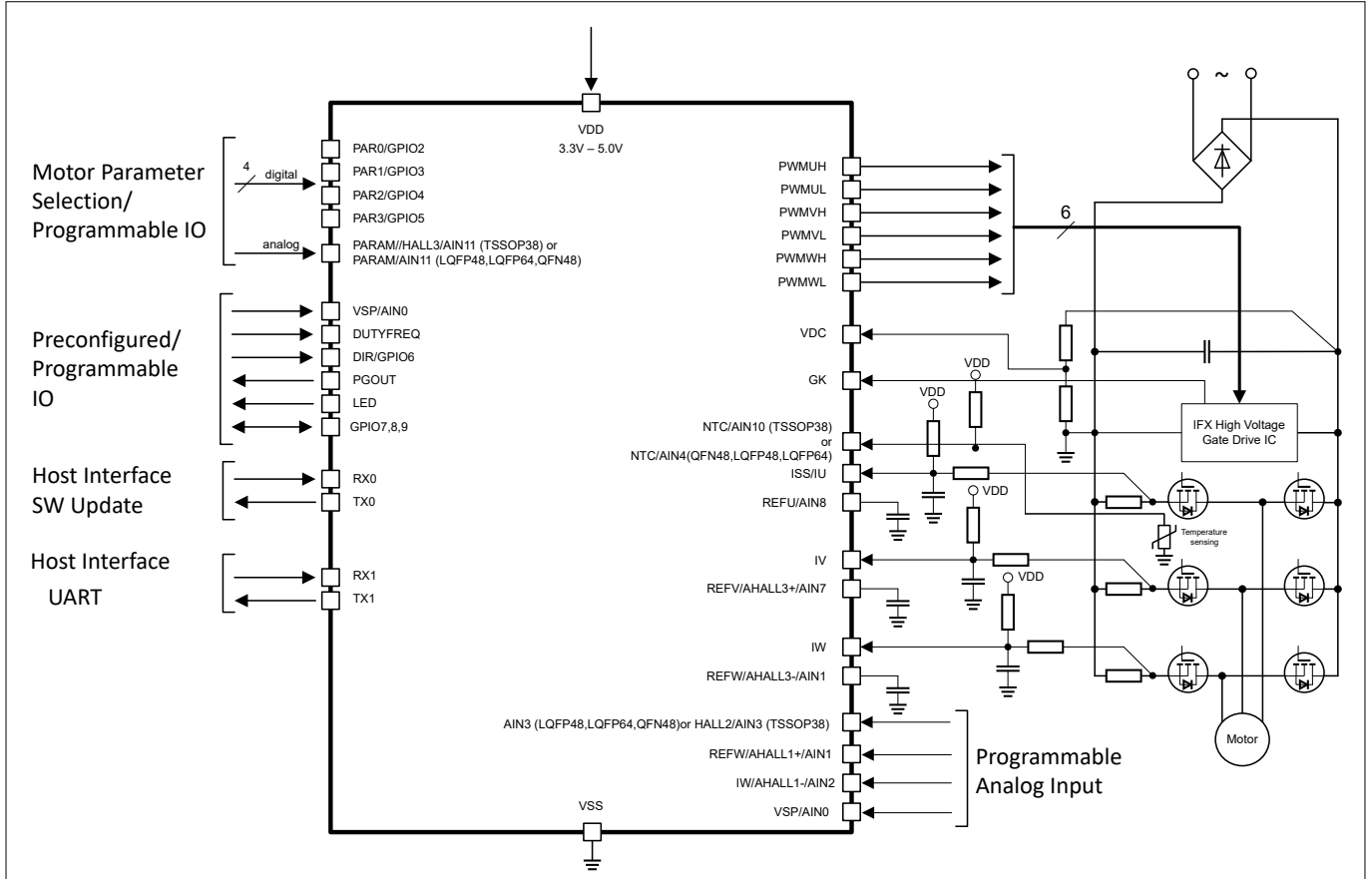

Figure 10 IMC101 in leg shunt configuration

3 Functional description

3.4 Application schematic motor control plus boost PFC

Figure 11 gives the schematic diagram for a motor control system with boost PFC using the IMC102 in sensorless operation and single shunt mode. An NTC can be used for temperature sensing at the power stage.

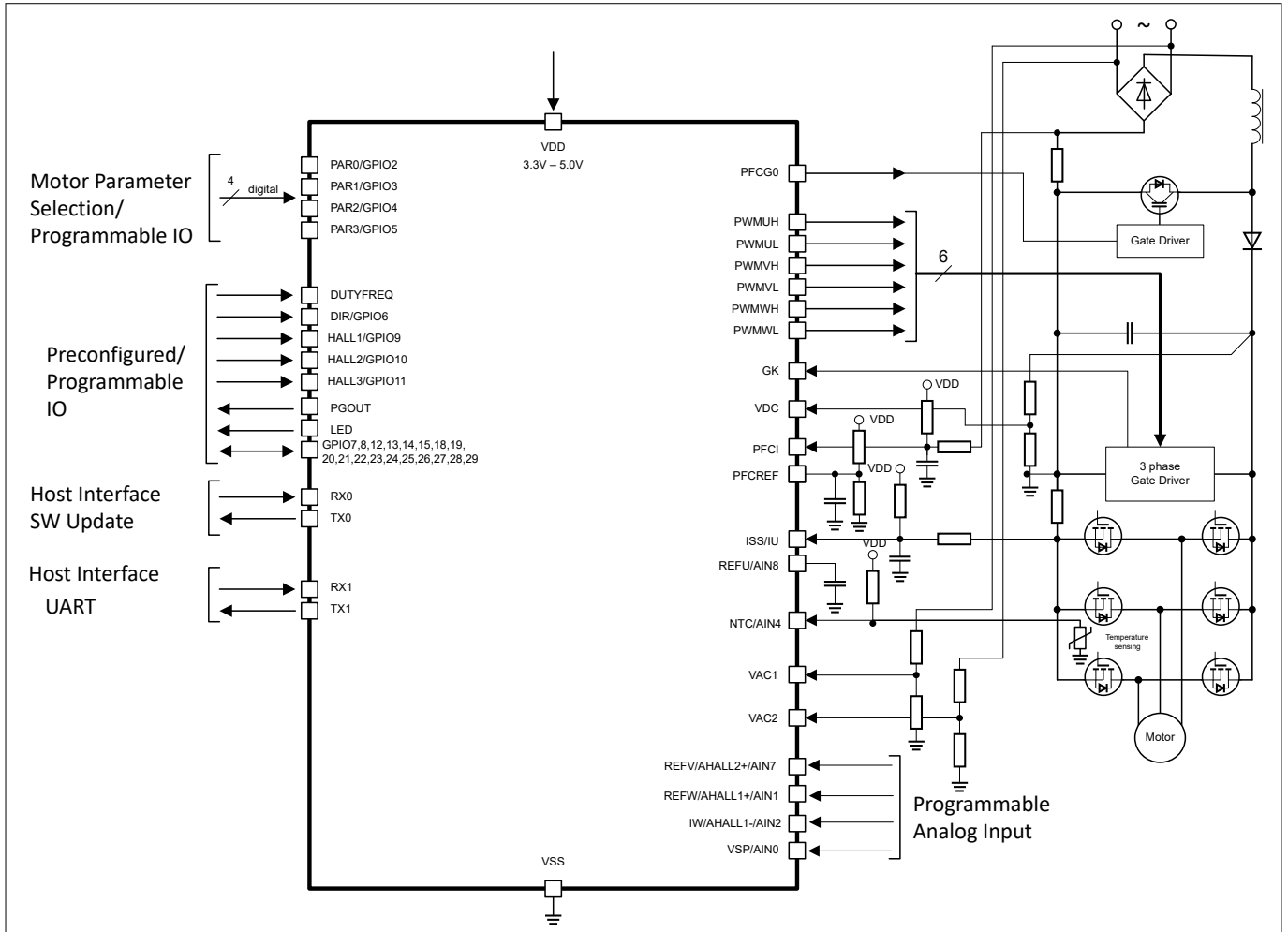

Figure 11 IMC102 in single shunt configuration with boost PFC control

3 Functional description

3.5 Application schematic motor control plus totem pole PFC

Figure 12 gives the schematic diagram for a motor control system with totem pole PFC using the IMC102 in sensorless operation and single shunt mode.

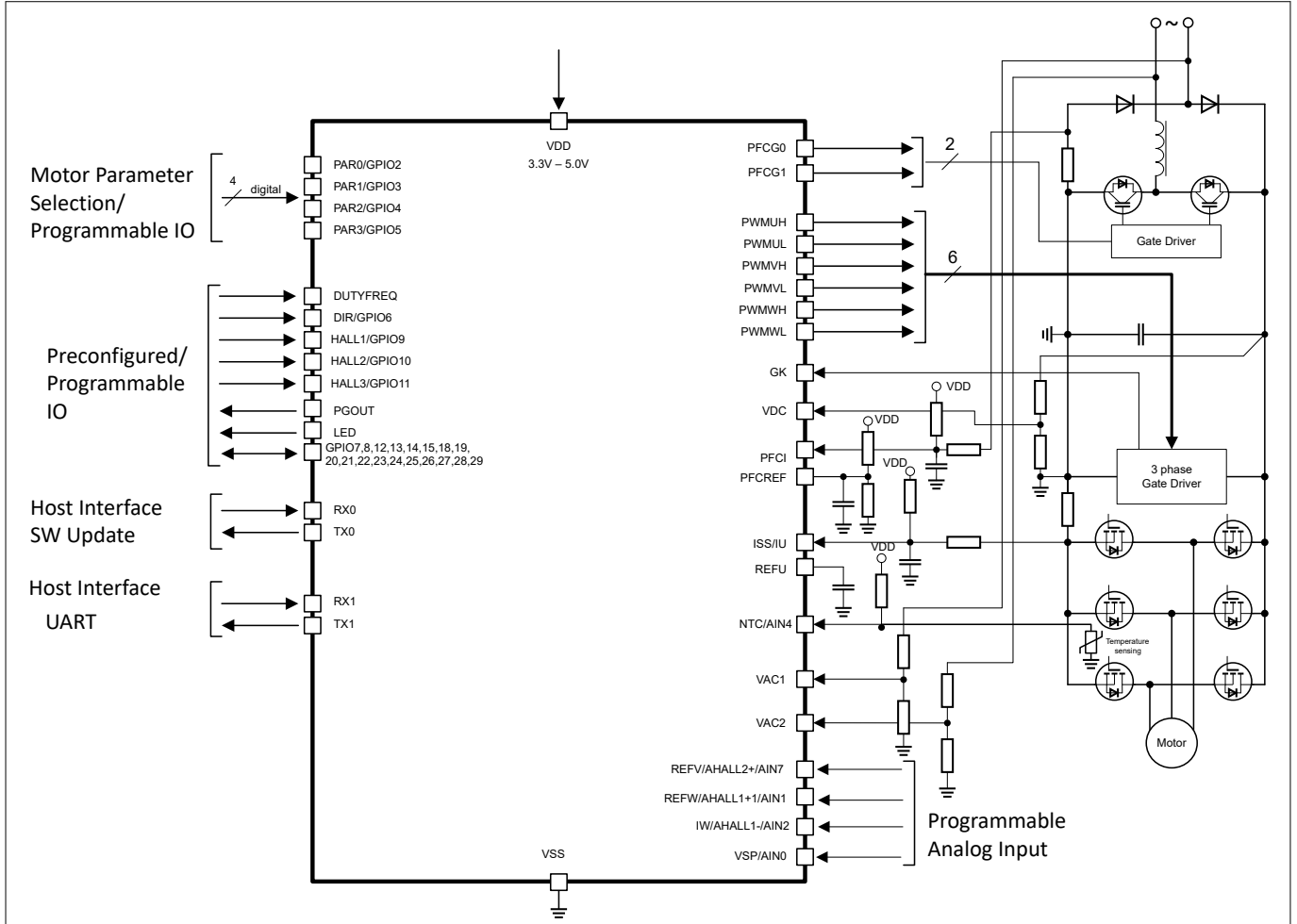

Figure 12 IMC102 in single shunt configuration with totem pole PFC

4 Electrical characteristics and parameters

4 Electrical characteristics and parameters

4.1 General parameters

4.1.1 Parameter Interpretation

The parameters listed in this section represent partly the characteristics of the IMC100 and partly its requirements on the system. To aid interpreting the parameters easily when evaluating them for a design, they are indicated by the abbreviations in the “Symbol” column:

- **CC**
Such parameters indicate **C**ontroller **C**haracteristics, which are distinctive feature of the IMC100 and must be regarded for a system design.
- **SR**
Such parameters indicate **S**ystem **R**equirements, which must be provided by the application system in which the IMC100 is designed in.

4.1.2 Absolute maximum ratings

Stresses above the values listed under “Absolute Maximum Ratings” may cause permanent damage to the device. This is a stress rating only and functional operation of the device at these or any other conditions above those indicated in the operational sections of this specification is not implied. Exposure to absolute maximum rating conditions may affect device reliability.

Table 3 Absolute maximum ratings

Parameter	Symbol	Values		Unit	Note or Test Condition
		Min.	Max.		
Ambient temperature	T_A SR	-40	105	°C	
Junction temperature	T_J SR	-40	115	°C	Digital controller
Storage temperature	T_{ST} SR	-40	125	°C	
Lead temperature (soldering, 30 seconds)	T_L SR	---	260	°C	
Digital Controller voltage	V_{DD} SR	-0.3	6	V	
Controller digital and analog pin voltage	V_{ID} SR	-0.3	$V_{DD}+0.3$	V	
Input current on any controller pin during overload condition	I_{IN} SR	-10	10	mA	
Absolute sum of all controller input currents during overload condition	ΣI_{IN} SR	-50	50	mA	

Note: Characterized, not tested at manufacturing.

Note: Voltages referenced to V_{SS} if not stated otherwise

4 Electrical characteristics and parameters

4.1.3 Pin Reliability in Overload

When receiving signals from higher voltage devices, low-voltage devices experience overload currents and voltages that go beyond their own IO power supplies specification.

The table below defines overload conditions that will not cause any negative reliability impact if all the following conditions are met:

- full operation life-time is not exceeded
- **Operating Conditions** are met for
 - pad supply levels (V_{DD})
 - temperature

If a pin current is outside of the **Operating Conditions** but within the overload conditions, then the parameters of this pin as stated in the Operating Conditions can no longer be guaranteed. Operation is still possible in most cases but with relaxed parameters.

Note: An overload condition on one or more pins does not require a reset.

Note: A series resistor at the pin to limit the current to the maximum permitted overload current is sufficient to handle failure situations like short to battery.

Table 4 Overload Parameters

Parameter	Symbol	Values			Unit	Note or Test Condition
		Min.	Typ.	Max.		
Input current on analog port pins during overload condition	I_{OVA} SR	-3	-	3	mA	
Input current on any port pin during overload condition	I_{OV} SR	-5	-	5	mA	
Absolute sum of all input currents during overload condition	I_{OVS} SR	-	-	25	mA	

Figure 13 shows the path of the input currents during overload via the ESD protection structures. The diodes against V_{DD} and ground are a simplified representation of these ESD protection structures.

4 Electrical characteristics and parameters

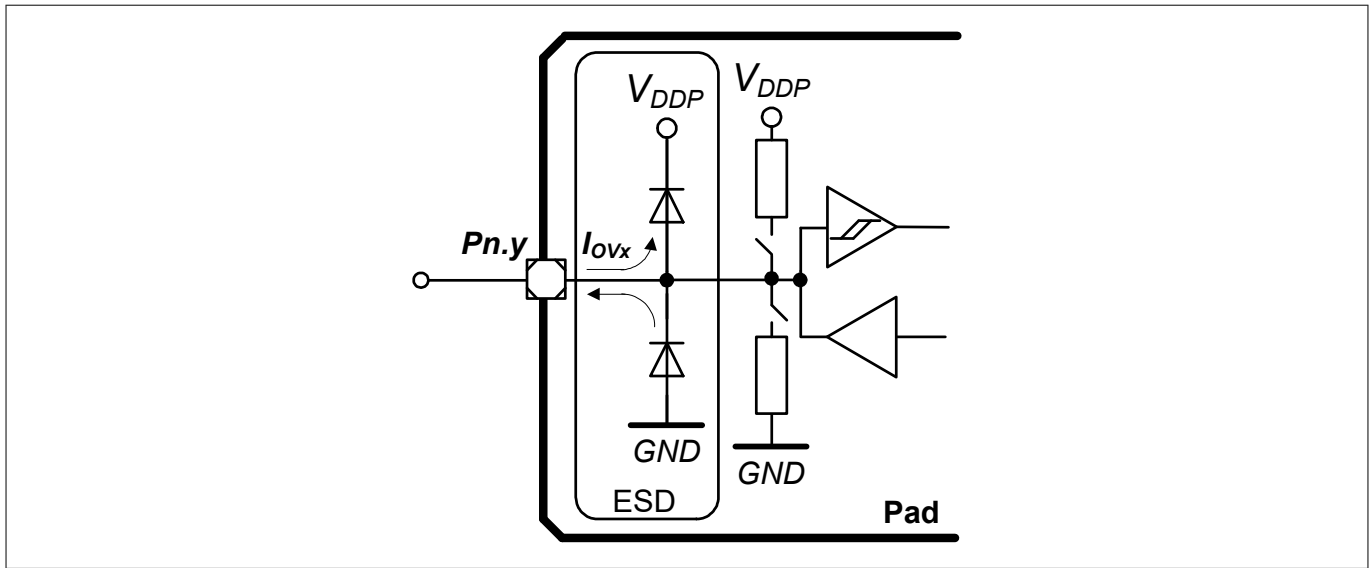

Figure 13 Input Overload Current via ESD structures

Table 5 and Table 6 list input voltages that can be reached under overload conditions. Note that the absolute maximum input voltages as defined in the Absolute maximum ratings must not be exceeded during overload.

Table 5 PN-Junction Characteristics for positive Overload

Pad Type	$I_{OV} = 5 \text{ mA}$
Standard, High-current, AN/DIG_IN	$V_{IN} = V_{DD} + (0.3 \dots 0.5) \text{ V}$ $V_{AIN} = V_{DD} + 0.5 \text{ V}$ $V_{AREF} = V_{DD} + 0.5 \text{ V}$

Table 6 PN-Junction Characteristics for negative Overload

Pad Type	$I_{OV} = 5 \text{ mA}$
Standard, High-current, AN/DIG_IN	$V_{IN} = V_{SS} - (0.3 \dots 0.5) \text{ V}$ $V_{AIN} = V_{SS} - 0.5 \text{ V}$ $V_{AREF} = V_{SS} - 0.5 \text{ V}$

4.1.4 Operating Conditions

The following operating conditions must not be exceeded in order to ensure correct operation and reliability of the IMC100. All parameters specified in the following tables refer to these operating conditions, unless noted otherwise.

Table 7 Recommended Operating Conditions

Parameter	Symbol	Values			Unit	Note or Test Condition
		Min.	Typ.	Max.		
Ambient Temperature	T_A SR	-40	-	105	°C	
Junction temperature	T_J SR	-40	-	115	°C	
Digital supply voltage ³⁾	V_{DD} SR	3.0	3.3	5.5	V	

³⁾ All supply pins must be driven with the same voltage.

4 Electrical characteristics and parameters

4.2 DC characteristics

4.2.1 Input/Output Characteristics

The table below provides the characteristics of the input/output pins of the controller.

Note: These parameters are not subject to production test, but verified by design and/or characterization.

Note: Unless otherwise stated, input DC and AC characteristics, including peripheral timings, assume that the input pads operate with the standard hysteresis.

Table 8 Input/Output Characteristics (Operating Conditions apply)

Parameter	Symbol		Limit Values		Unit	Test Conditions
			Min.	Max.		
Input low voltage on port pins (Standard Hysteresis)	V_{ILPS}	SR	–	$0.19 \times V_{DD}$	V	CMOS Mode
Input high voltage on port pins (Standard Hysteresis)	V_{IHPS}	SR	$0.7 \times V_{DD}$	–	V	CMOS Mode
Input low voltage on port pins (Large Hysteresis, scripting pins only)	V_{ILPL}	SR	–	$0.08 \times V_{DD}$	V	CMOS Mode
Input high voltage on port pins (Large Hysteresis, scripting pins only)	V_{IHPL}	SR	$0.85 \times V_{DD}$	–	V	CMOS Mode
Output low voltage on port pins	V_{OLP}	CC	–	1.0	V	$I_{OL} = 11 \text{ mA (5 V)}$ $I_{OL} = 7 \text{ mA (3.3 V)}$
			–	0.4	V	$I_{OL} = 5 \text{ mA (5 V)}$ $I_{OL} = 3.5 \text{ mA (3.3 V)}$
Output low voltage on PWM outputs	V_{OLP1}	CC	–	1.0	V	$I_{OL} = 50 \text{ mA (5 V)}$ $I_{OL} = 25 \text{ mA (3.3 V)}$
			–	0.32	V	$I_{OL} = 10 \text{ mA (5 V)}$
			–	0.4	V	$I_{OL} = 5 \text{ mA (3.3 V)}$
Output high voltage on port pins	V_{OHP}	CC	$V_{DD} - 1.0$	–	V	$I_{OH} = -10 \text{ mA (5 V)}$ $I_{OH} = -7 \text{ mA (3.3 V)}$
			$V_{DD} - 0.4$	–	V	$I_{OH} = -4.5 \text{ mA (5 V)}$ $I_{OH} = -2.5 \text{ mA (3.3 V)}$
Output high voltage on PWM outputs	V_{OHP1}	CC	$V_{DD} - 0.32$	–	V	$I_{OH} = -6 \text{ mA (5 V)}$
			$V_{DD} - 1.0$	–	V	$I_{OH} = -8 \text{ mA (3.3 V)}$
			$V_{DD} - 0.4$	–	V	$I_{OH} = -4 \text{ mA (3.3 V)}$
Rise/fall time on PWM outputs ⁴⁾	t_{HCPR} , t_{HCPF}	CC	–	9	ns	50 pF @ 5 V

(table continues...)

4 Electrical characteristics and parameters

Table 8 (continued) Input/Output Characteristics (Operating Conditions apply)

Parameter	Symbol		Limit Values		Unit	Test Conditions
			Min.	Max.		
			-	12	ns	50 pF @ 3.3 V
Rise/fall time on standard pad	t_R, t_F	CC	-	12	ns	50 pF @ 5 V
			-	15	ns	50 pF @ 3.3 V.
Pin capacitance (digital inputs/outputs)	C_{IO}	CC	-	10	pF	
Pull-up/-down resistor on port pins (if enabled in software)	R_{PUP}	CC	20	50	kΩ	$V_{IN} = V_{SS}$
Input leakage current ⁵⁾	I_{OZP}	CC	-1	1	μA	$0 < V_{IN} < V_{DD}$, $T_A 105^\circ\text{C}$
Maximum current per pin standard pin	I_{MP}	SR	-10	11	mA	-
Maximum current per PWM outputs pins	I_{MP1A}	SR	-10	50	mA	-
Maximum current into V_{DD} / out of V_{SS}	I_{MVDD} / I_{MVSS}	SR	-	260	mA	

⁴ Rise/Fall time parameters are taken with 10% - 90% of supply.

⁵ An additional error current (I_{INJ}) will flow if an overload current flows through an adjacent pin.

4 Electrical characteristics and parameters

4.2.2 Analog to Digital Converter (ADC)

The following table shows the Analog to Digital Converter (ADC) characteristics. This specification applies to all analog input including the analog Hall sensor interface input (AHALLx+/AHALLx-, where x=1,2) as given in the pin configuration list.

Note: These parameters are not subject to production test, but verified by design and/or characterization.

Table 9 ADC Characteristics (Operating Conditions apply)⁶⁾

Parameter	Symbol	Values			Unit	Note or Test Condition
		Min.	Typ.	Max.		
Supply voltage range	V _{DD} SR	3.0	–	5.5	V	
Analog input voltage range	V _{AIN} SR	V _{SS} - 0.05	–	V _{DD} + 0.05	V	
Conversion time	t _{C12} CC	–	1.0	–	μs	Defined by SW
Total capacitance of an analog input	C _{AIN} CC	–	–	10	pF	
Total capacitance of the reference input	C _{AREFT} CC	–	–	10	pF	
Sample time	t _{sample} CC	–	333	–	ns	Defined by SW
RMS noise	EN _{RMS} CC	–	1.5	–	LSB12	
DNL error	EA _{DNL} CC	–	±2.0	–	LSB12	
INL error	EA _{INL} CC	–	±4.0	–	LSB12	
Gain error	EA _{GAIN} CC	–	±0.5	–	%	
Offset error	EA _{OFF} CC	–	±8.0	–	mV	

4.2.3 Analog comparator characteristics

The table below shows the Analog Comparator characteristics.

Note: These parameters are not subject to production test, but verified by design and/or characterization.

Table 10 Analog Comparator Characteristics (Operating Conditions apply)

Parameter	Symbol		Values			Unit	Note or Test Conditions
			Min.	Typ.	Max.		
Input Voltage	V _{CMP}	SR	-0.05	–	V _{DDP} + 0.05	V	includes common mode and differential input voltages
Input Offset	V _{CMPOFF}	CC	–	+/-3	–	mV	High power mode ΔV _{CMP} < 200 mV
Input Hysteresis	V _{HYS}	CC	–	+/-15	–	mV	Defined by SW

⁶⁾ All parameters are defined for the full supply range if not stated otherwise.

4 Electrical characteristics and parameters

4.2.4 Power Supply Current Controller

The total power supply current defined below consists of a leakage and a switching component for the controller through the V_{DD} pin.

Application relevant values are typically lower than those given in the following tables, and depend on the customer's system operating conditions (e.g. thermal connection or used application configurations).

Note: These parameters are not subject to production test, but verified by design and/or characterization.

Table 11 Power supply parameter table $V_{DD}= 5.0V$

Parameter	Symbol	Values			Unit	Note or Test Condition
		Min.	Typ.	Max.		
Active mode current motor control only	$I_{DD1\ CC}$	–	10	20	mA	$T_a = 25^\circ C$
Active mode current motor control plus PFC	$I_{DD2\ CC}$	–	16	20	mA	$T_a = 25^\circ C$

4.2.5 Flash Memory Parameters

Note: These parameters are not subject to production test, but verified by design and/or characterization.

Table 12 Flash Memory Parameters

Parameter	Symbol	Values			Unit	Note or Test Condition
		Min.	Typ.	Max.		
Data Retention Time	$t_{RET\ CC}$	10			years	Max. 100 erase / program cycles
Erase Cycles	$N_{ECCY\ CC}$			$5 \cdot 10^4$	cycles	Sum of page and sector erase cycles a page sees
Total Erase Cycles	$N_{TECCY\ CC}$			$2 \cdot 10^6$	cycles	

4 Electrical characteristics and parameters

4.3 AC characteristics

4.3.1 Testing Waveforms

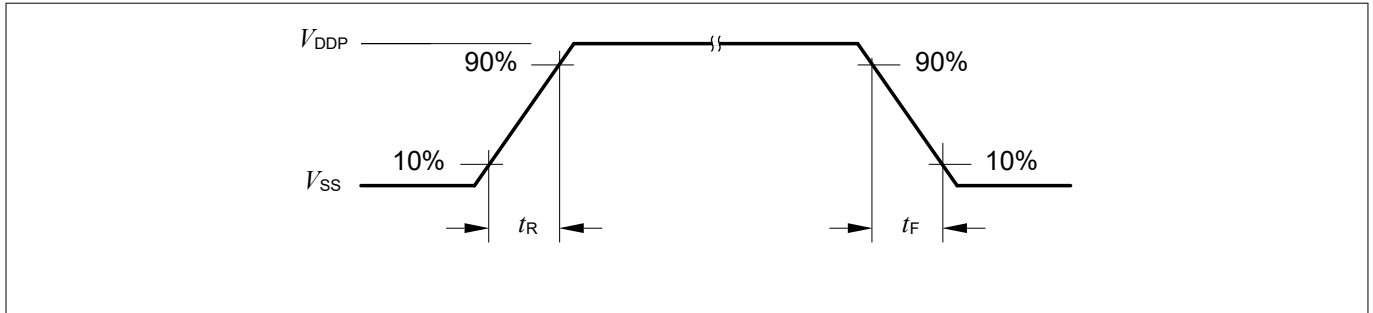

Figure 14 Rise/Fall Time Parameters

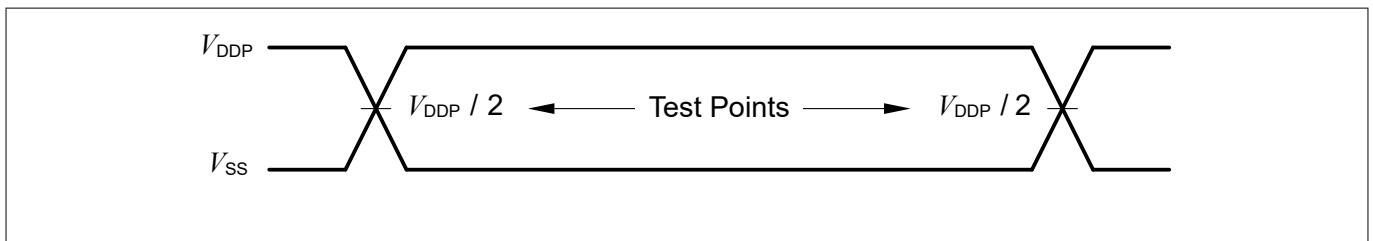

Figure 15 Testing Waveform, Output Delay

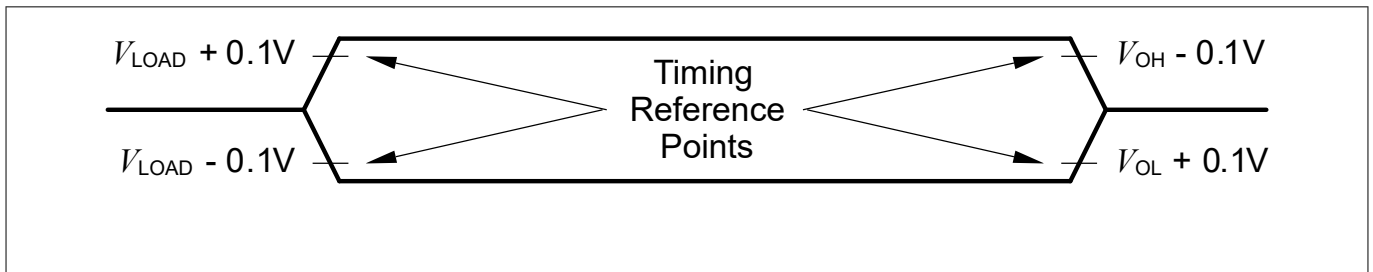

Figure 16 Testing Waveform, Output High Impedance

4.3.2 Power-Up and Supply Threshold Characteristics

This chapter provides the characteristics of the supply threshold for the controller.

The guard band between the lowest valid operating voltage and the brownout reset threshold provides a margin for noise immunity and hysteresis. The electrical parameters may be violated while V_{DD} is outside its operating range.

The brownout detection triggers a reset within the defined range. The prewarning detection can be used to trigger an early warning and issue corrective and/or fail-safe actions in case of a critical supply voltage drop.

Note: These parameters are not subject to production test, but verified by design and/or characterization.

Note: Operating Conditions apply.

4 Electrical characteristics and parameters

Table 13 Power-Up and Supply Threshold Parameters

Parameter	Symbol	Values			Unit	Note or Test Condition
		Min.	Typ.	Max.		
V_{DD} ramp-up time	t_{RAMPUP} SR	$V_{DD}/S_{VDDrise}$	–	10^7	μs	
V_{DD} slew rate	S_{VDDOP} SR	0	–	0.1	$V/\mu s$	Slope during normal operation
	S_{VDD10} SR	0	–	10	$V/\mu s$	Slope during fast transient within +/-10% of V_{DD}
	$S_{VDDrise}$ SR	0	–	10	$V/\mu s$	Slope during power-on or restart after brownout event
	$S_{VDDfall}^{7)}$ SR	0	–	0.25	$V/\mu s$	Slope during supply falling out of the +/-10% limits ⁸⁾
V_{DD} prewarning voltage	V_{DDPW} CC	2.1	2.25	2.4	V	ANAVDEL.VDEL_SELECT = 00 _B
		2.85	3	3.15	V	ANAVDEL.VDEL_SELECT = 01 _B
		4.2	4.4	4.6	V	ANAVDEL.VDEL_SELECT = 10 _B
V_{DD} brownout reset voltage	V_{DDBO} CC	1.55	1.62	1.75	V	calibrated, before user code starts running
V_{DD} voltage to ensure defined pad states	V_{DDA} CC	–	1.0	–	V	
Start-up time from power-on reset	t_{SSW} CC	–	260	–	μs	Time to the first user code instruction ⁹⁾
Start-up time to PWM on	t_{PWMON} CC	5.2	–	360	ms	Time to PWM enabled



Figure 17 Supply Threshold Parameters

⁷ A capacitor of at least 100 nF has to be added between VDD and VSS to fulfill the requirement as stated for this parameter.
⁸ Valid for a 100 nF buffer capacitor connected to supply pin where current from capacitor is forwarded only to the chip. A larger capacitor value has to be chosen if the power source sink a current.
⁹ This values does not include the ramp-up time. During startup firmware execution, MCLK is running at 48 MHz and the clocks to peripheral as specified in register CGATSTAT0 are gated.

4 Electrical characteristics and parameters

4.3.3 On-Chip Oscillator Characteristics

Table 14 provides the characteristics of the 96 MHz digital controlled oscillator DCO1. The DCO1 is used as the time base during normal operation.

Note: These parameters are not subject to production test, but verified by design and/or characterization.

Table 14 96 MHz DCO1 Characteristics

Parameter	Symbol	Limit Values			Unit	Test Conditions
		Min.	Typ.	Max.		
Nominal frequency	$f_{\text{NOM CC}}$	-	96	-	MHz	under nominal conditions after trimming
Accuracy with adjustment algorithm ¹⁰⁾ based on temperature sensor	$\Delta f_{\text{LTTS CC}}$	-0.6	-	+0.6	%	with respect to $f_{\text{NOM}}(\text{typ})$, T_A from 0°C to 105°C
		-1.9	-	+1.0	%	with respect to $f_{\text{NOM}}(\text{typ})$, T_A from -25°C to 105°C
		-2.6	-	+1.3	%	with respect to $f_{\text{NOM}}(\text{typ})$, T_A from -40°C to 105°C
Accuracy	$\Delta f_{\text{LT CC}}$	-1.7	-	+3.4	%	with respect to $f_{\text{NOM}}(\text{typ})$, T_A from 0°C to 85°C
		-3.9	-	+4.0	%	with respect to $f_{\text{NOM}}(\text{typ})$, T_A from -40°C to 105°C

Table 15 provides the characteristics of the 32 kHz digital controlled oscillator used internally as a secondary clock source for the internal watchdog.

Table 15 32 kHz DCO2 Characteristics

Parameter	Symbol	Limit Values			Unit	Test Conditions
		Min.	Typ.	Max.		
Nominal frequency	$f_{\text{NOM CC}}$	-	32.75	-	kHz	under nominal conditions ¹¹⁾ after trimming
Accuracy	$\Delta f_{\text{LT CC}}$	-1.7	-	+3.4	%	with respect to $f_{\text{NOM}}(\text{typ})$, T_A from 0°C to 85°C
		-3.9	-	+4.0	%	with respect to $f_{\text{NOM}}(\text{typ})$, T_A from -40°C to 105°C

¹⁰⁾ MCE version newer or equal to V1.03.00, clock adjustment algorithm for improved accuracy enabled

¹¹⁾ The deviation is relative to the factory trimmed frequency at nominal V_{DC} and $T_A = +25^\circ\text{C}$.

4 Electrical characteristics and parameters

4.4 Motor Control Parameters

The following values are given for reference only. Concrete parameters are defined in the iMOTION™ Motion Control Engine (MCE) software.

4.4.1 PWM Characteristics

Table 16 Electrical characteristics

Parameter	Symbol	Values			Unit	Note or test condition
		Min.	Typ.	Max.		
Motor PWM Frequency ¹²⁾	f _{PWM}	5	16	40	kHz	

4.4.2 Current Sensing

Table 17 Motor Current Sensing

Parameter	Symbol	Values			Unit	Note or test condition
		Min.	Typ.	Max.		
Input range	I _{PWM}	V _{SS} -0.05	-	V _{DD} +0.05	V	
Configurable analog gain		-	1/ 3/ 6/ 12	-		
Itrip input range	I _{PWMTRIP}	V _{SS} -0.05	-	V _{DD} +0.05	V	
Itrip offset		-	±8	-	mV	
Input capacitance	C _{REF}	-	-	10	pF	REFU, REFV, REFW capacitor

¹²⁾ Actual min. and max. limits defined in resp. software version

4 Electrical characteristics and parameters

4.4.3 Fault Timing

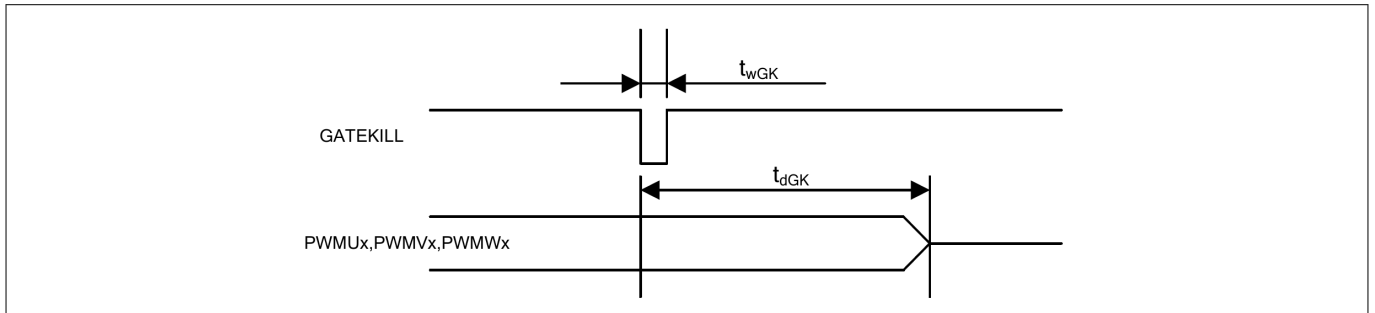

Figure 18 Fault timing

Table 18 Gatekill timing

Parameter	Symbol	Values			Unit	Note or test condition
		Min.	Typ.	Max.		
GK pulse width	t_{wGK}	1	-	-	μs	
GK input to PWM shutoff	t_{dGK}	-	1.3	-	μs	
Motor Fault reset timing	t_{RESET}	-	1.84	-	ms	fault reset command via UART to PWM reactivation
MCE digital ITRIP filter window	t_{PWWOFF}	0.075	1.0	10	μs	Configurable in software

Note: The ITRIP filter window must be configured according to the rated short circuit withstand time of the respective power stage taking into consideration any delay in external circuitry. For iMOTION™ devices with integrated power stage the value is specified in the Absolute maximum ratings of the device.

4 Electrical characteristics and parameters

4.5 Power Factor Correction (PFC) parameters

The parameters specified for the power factor correction only refer to products that have the respective control algorithm integrated. The PFC switching frequency is configurable and the range depends on the concrete firmware version.

4.5.1 Boost PFC characteristics

Table 19 Electrical characteristics

Parameter	Symbol	Values			Unit	Note or test condition
		Min.	Typ.	Max.		
PFC frequency	f_{PFC}	-	20	50	kHz	MCE rev. 1.3
		-	40	120		MCE rev. 5.1

4.5.2 Totem Pole PFC characteristics

Table 20 Electrical characteristics

Parameter	Symbol	Values			Unit	Note or test condition
		Min.	Typ.	Max.		
PFC frequency	f_{PFC}	-	40		kHz	Max defined by SW

4.5.3 PFC Current Sensing

The current sensing specification applies to both PFC algorithms, boost mode and totem pole.

Table 21 PFC Current Sensing

Parameter	Symbol	Values			Unit	Note or test condition
		Min.	Typ.	Max.		
Input range	I_{PFC}	$V_{SS} - 0.05$	-	$V_{DD} + 0.05$	V	$V_{DD} = 3.3$ or 5.0 V
Configurable analog gain		-	1/ 3/ 6/ 12	-		
PFC Itrip input range	$I_{PFCTRIP}$	$V_{SS} - 0.05$	-	$V_{DD} + 0.05$	V	$V_{DD} = 3.3$ or 5.0 V
Itrip offset		-	± 3	-	mV	Input voltage difference > 200mV
Input capacitance	C_{REF}	-	-	10	pF	PFCREF capacitor

4.5.4 PFC Fault Timing

Table 22 PFC Fault timing

Parameter	Symbol	Values			Unit	Note or test condition
		Min.	Typ.	Max.		
Itrip to PFC PWM shutoff	t_{PFCOFF}	-	1.18	-	μ S	

(table continues...)

4 Electrical characteristics and parameters

Table 22 (continued) PFC Fault timing

Parameter	Symbol	Values			Unit	Note or test condition
		Min.	Typ.	Max.		
PFC fault reset timing	t_{RESET}	-	1.0	-	ms	fault reset command via UART to PWM reactivation

4 Electrical characteristics and parameters

4.6 Device Interfaces

iMOTION™ devices provide several interfaces to either control the motor drive in the application or report back its status. The availability of a specific interface depends upon the concrete device chosen as well as the version of the Motion Control Engine (MCE) applied. The following sections and tables specify these interfaces as well as the respective limits. The configuration settings for these interfaces are described in the MCE Reference Manual.

Note: These parameters are not subject to production test, but verified by design and/or characterization. Operating conditions apply.

4.6.1 UART Interface

The UART interface is configured as given below.

Table 23 Electrical characteristics

Parameter	Symbol	Values			Unit	Note or test condition
		Min.	Typ.	Max.		
UART baud rate		1200	57600	-	Bps	
UART mode		-	8-N-1	-		data-parity-stop bit
UART sampling filter period ¹³⁾	$T_{UARTFIL}$	-	1/16	-	T_{BAUD}	

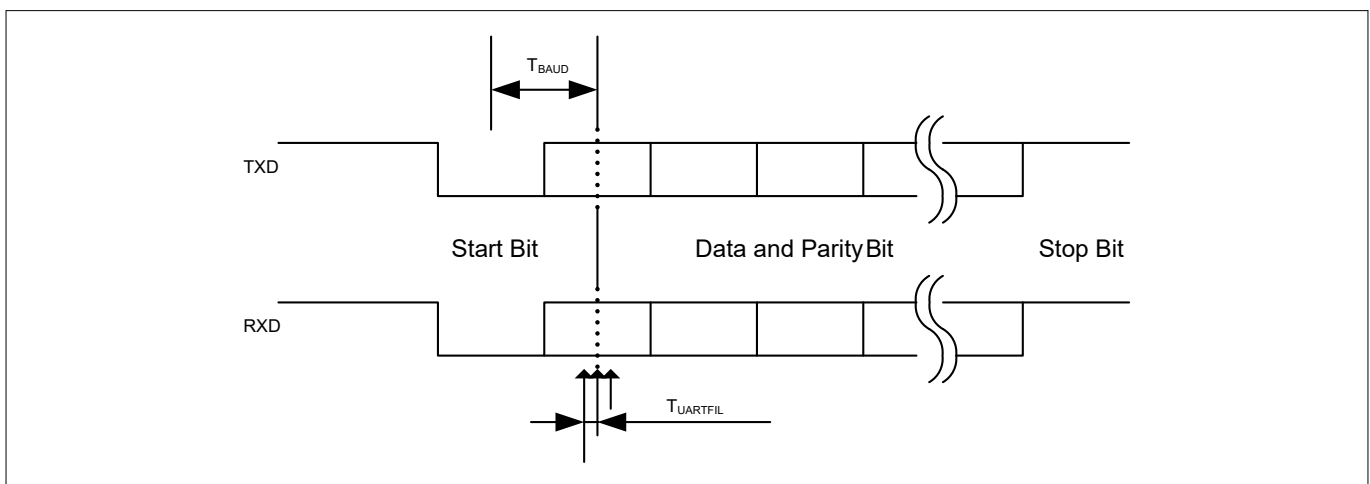

Figure 19 UART timing

¹³⁾ Each bit including start and stop bit is sampled three times at center of a bit at an interval of $1/16 T_{BAUD}$. If three sampled values do not agree, then UART noise error is generated.

4 Electrical characteristics and parameters

4.6.2 Analog Speed Input

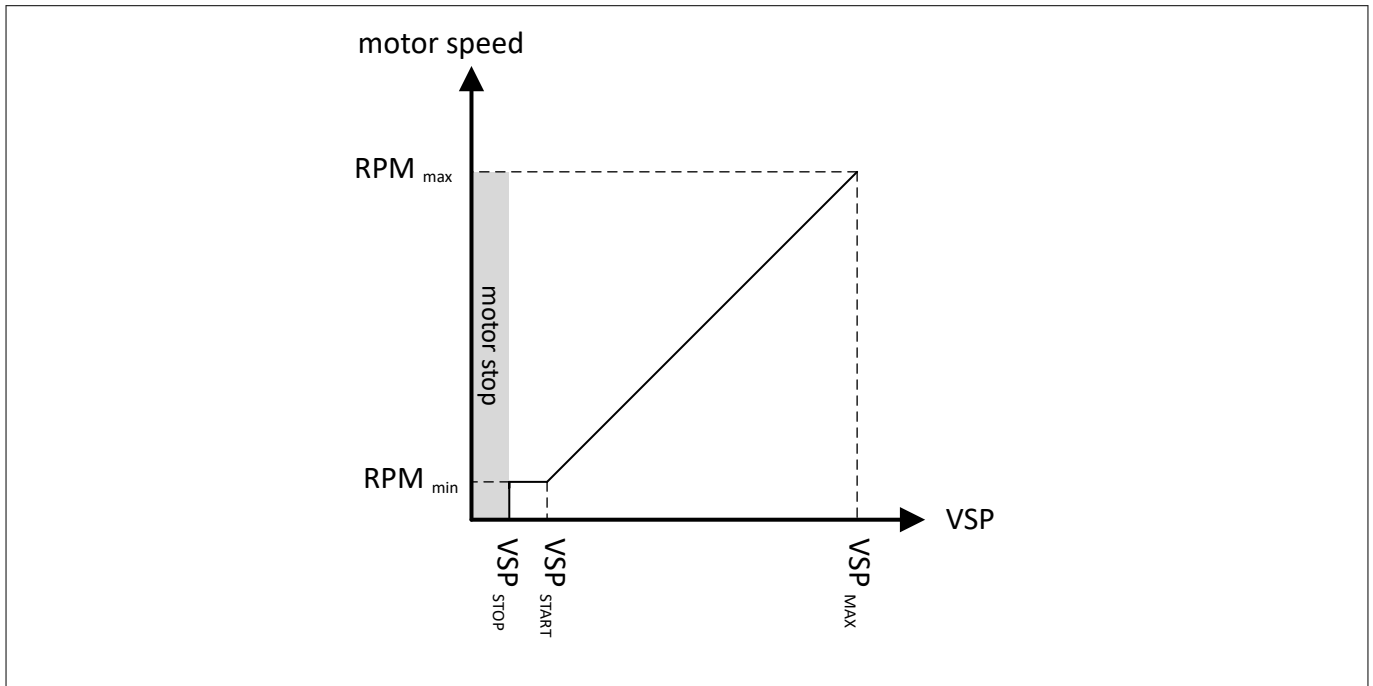

Figure 20 VSP analog control mode

Table 24 Analog Speed Control Voltage (VSP)

Parameter	Symbol	Values			Unit	Note or test condition
		Min.	Typ.	Max.		
Motor start voltage	VSP_{START}	-	1.2	-	V	Configured $VSP_{START}=1.0V$
Motor stop voltage	VSP_{STOP}	-	1.0	-	V	Configured $VSP_{STOP}=1.0V$
Motor max voltage	VSP_{MAX}	-	4.9	4.95	V	$V_{DD}=5.0V$
VSP active to PWM start	t_{START}	-	44	-	ms	
VSP inactive to PWM stop	t_{STOP}	-	16	-	ms	

4 Electrical characteristics and parameters

4.6.3 Frequency Input

In frequency input control mode, the motor operations like motor start, motor stop and speed change are controlled by applying a square wave frequency signal on a digital input pin.

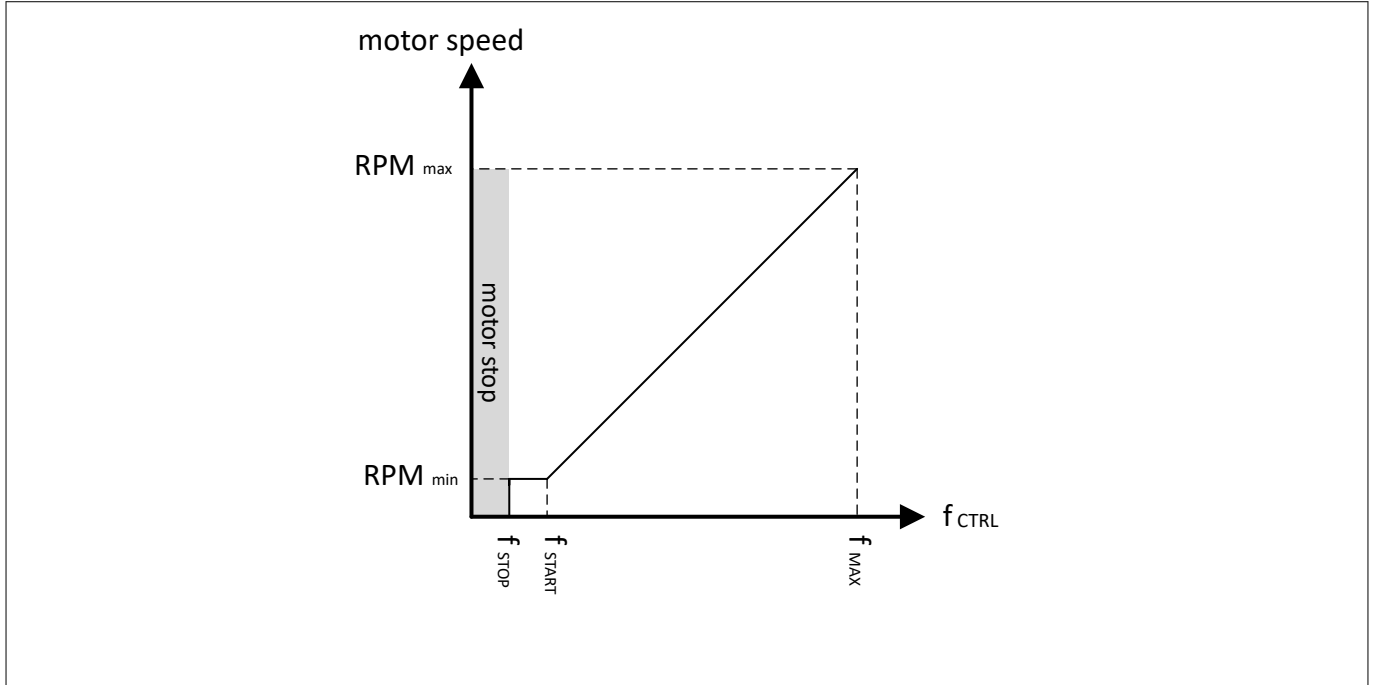

Figure 21 Frequency input control mode

Table 25 Frequency Control Mode

Parameter	Symbol	Values			Unit	Note or test condition
		Min.	Typ.	Max.		
Motor start frequency	f_{START}	-	100	360	Hz	$f_{START} > f_{STOP}$
Motor stop frequency	f_{STOP}	-	50	-	Hz	
Motor max speed frequency	f_{MAX}	-	-	1000	Hz	
Frequency input duty cycle	T_{DUTY}	10	-	90	%	

4 Electrical characteristics and parameters

4.6.4 Duty Cycle Input

In duty cycle input control mode, the motor operations like motor start, stop and speed change are controlled by varying the duty cycle of a rectangular wave signal on a digital input pin.

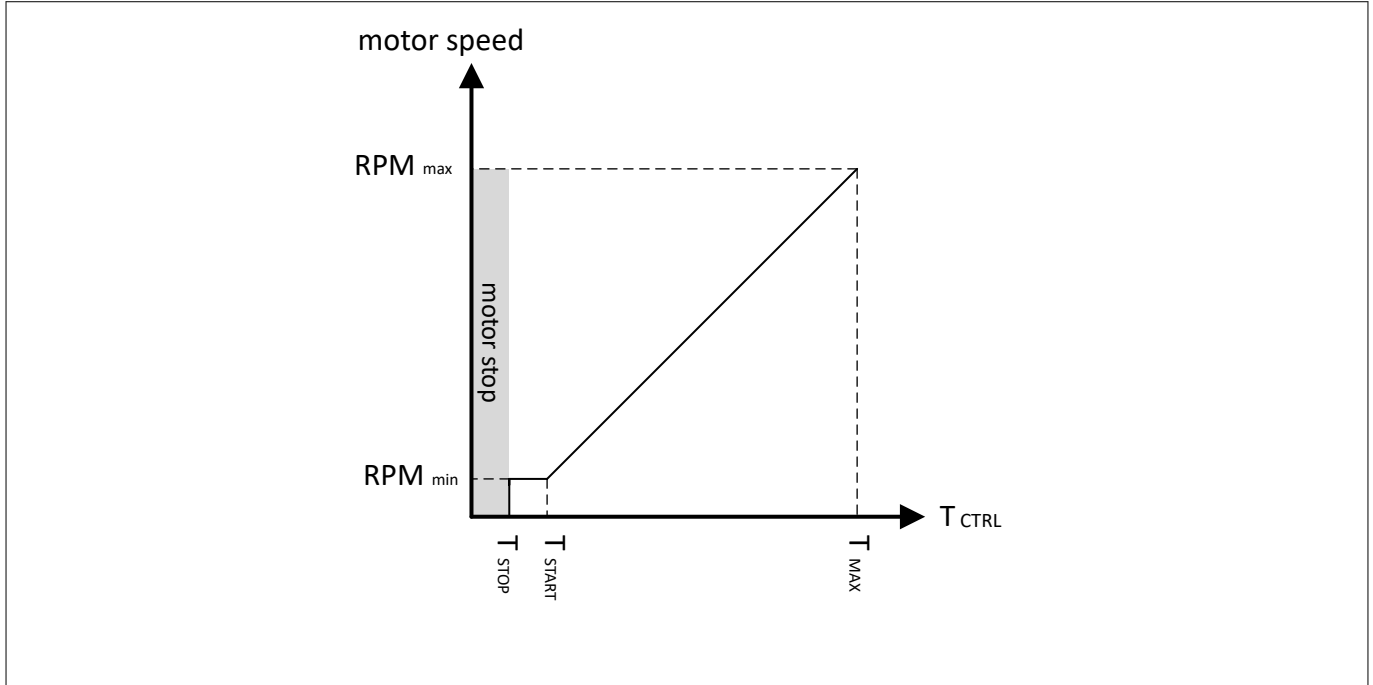

Figure 22 Duty cycle input control mode

Table 26 Duty Cycle Control Mode

Parameter	Symbol	Values			Unit	Note or test condition
		Min.	Typ.	Max.		
Input signal frequency	f_{DUTY}	5	1000	20000	Hz	
Motor start duty cycle	T_{START}	-	10	-	%	$T_{START} > T_{STOP}$
Motor stop duty cycle	T_{STOP}	-	5	-	%	
Motor max duty cycle	T_{MAX}	-	95	-	%	

4 Electrical characteristics and parameters

4.6.5 Over Temperature Input

The over temperature input can be used to continuously monitor an external temperature sensor like an NTC.

Table 27 Over Temperature Input

Parameter	Symbol	Values			Unit	Note or test condition
		Min.	Typ.	Max.		
Over Temperature to PWM shutdown	t_{OT}		1.0	2.1	ms	

4.6.6 Pulse Output

The IMC100 series can generate a square wave pulse output in sync with the motor rotation which can be used to monitor the motor speed. The number of pulses to be generated for a full rotation can be configured.

Table 28 Pulse Output

Parameter	Symbol	Values			Unit	Note or test condition
		Min.	Typ.	Max.		
Pulses per Rotation	PPR	4	-	24		
Pulse duty cycle	t_{PPR}	-	50	-	%	

4.6.7 LED Output

The IMC100 series provides an output that can be connected to an LED to give a visual indication of the status of the motor drive.

Table 29 LED Output

Parameter	Symbol	Values			Unit	Note or test condition
		Min.	Typ.	Max.		
Fault to LED delay	$t_{LEDFault}$	-	53	-	ms	
Fault reset to LED delay	$t_{LEDRESET}$	-	1.84	-	ms	
LED blinking frequency	f_{LED}	1		1000	Hz	
LED blinking duty cycle	t_{LED}	5		95	%	

5 Device and package specifications

5 Device and package specifications

5.1 Quality declaration

Table 30 Quality Parameters

Parameter	Symbol	Limit Values		Unit	Notes
		Min.	Max.		
ESD susceptibility according to Human Body Model (HBM)	V_{HBM} SR	–	2000	V	ANSI/ESDA/JEDEC-JS-001
ESD susceptibility according to Charged Device Model (CDM) pins	V_{CDM} SR	–	500	V	ANSI/ESDA/JEDEC-JS-002
Moisture sensitivity level	MSL CC	–	3	–	JEDEC J-STD-020D
Soldering temperature	T_{SDR} SR	–	260	°C	JEDEC J-STD-020D

5.2 SBSL and Chip-IDs

The table below gives the IDs for the individual devices in the IMC100 family. Depending upon the mode either the SBSL-ID (secure boot loader) or the Chip-ID should be used to identify the device. For details refer to the Reference Manual or the iMOTION™ Programming Manual.

Table 31 SBSL-IDs and Chip-IDs

Product Type	Package	Chip-ID	SBSL-ID
IMC099T-T038	TSSOP-38	0x10990005	02af86dbe4df1c3471cd41bfae101928
IMC101T-T038	TSSOP-38	0x11010005	02270f1fccdf57c333d31abd78f960b0
IMC101T-Q048	QFN-48	0x11010008	0244e4486f613c04e6539585aec5d311
IMC101T-F048	LQFP-48	0x11010006	023443609d83afdd5bbda261eb9469b4
IMC101T-F064	LQFP-64	0x1101000B	02a5cdc6d93bbfba0e3617fd7be5df07
IMC102T-F048	LQFP-48	0x11020006	02fc84949a9e41a3043571111137bffb
IMC102T-F064	LQFP-64	0x1102000B	0289426daa14293ab31828d8341ad4ef

5 Device and package specifications

5.3 Thermal Characteristics

Table 32 Thermal Characteristics of the Packages

Parameter	Symbol	Limit Values		Unit	Package Types
		Min.	Max.		
Exposed Die Pad Dimensions	Ex × Ey CC	-	4.2 x 4.2	mm	PG-VQFN-48-73
Thermal resistance Junction-Ambient ¹⁴⁾	R _{ΘJA} CC	-	86.0	K/W	PG-TSSOP-38-9
		-	44.9	K/W	PG-VQFN-48-73
		-	t.b.d.	K/W	PG-LQFP-48-10
		-	66.7	K/W	PG-LQFP-64-26

Note: For electrical reasons, it is required to connect an exposed pad to the board ground V_{SSP}, independent of EMC and thermal requirements.

When operating the IMC100 in a system, the total heat generated in the chip must be dissipated to the ambient environment to prevent overheating and the resulting thermal damage.

The maximum heat that can be dissipated depends on the package and its integration into the target board. The “Thermal resistance R_{ΘJA}” quantifies these parameters. The power dissipation must be limited so that the average junction temperature does not exceed 115 °C.

The difference between junction temperature and ambient temperature is determined by

$$\Delta T = (P_{INT} + P_{IOSTAT} + P_{IODYN}) \times R_{\Theta JA}$$

The internal power consumption is defined as

$$P_{INT} = V_{DD} \times I_{DDP} \text{ (switching current and leakage current).}$$

The static external power consumption caused by the output drivers is defined as

$$P_{IOSTAT} = \Sigma((V_{DD} - V_{OH}) \times I_{OH}) + \Sigma(V_{OL}I_{OL})$$

The dynamic external power consumption caused by the output drivers (P_{IODYN}) depends on the capacitive load connected to the respective pins and their switching frequencies.

If the total power dissipation for a given system configuration exceeds the defined limit, countermeasures must be taken to ensure proper system operation:

- Reduce V_{DD}, if possible in the system
- Reduce the system frequency
- Reduce the number of output pins
- Reduce the load on active output drivers

¹⁴⁾ Device mounted on a 4-layer JEDEC board (JESD 51-5); exposed pad of VQFN soldered.

5 Device and package specifications

5.4 Package Outlines

All dimensions in mm.

You can find complete information about Infineon packages, packing and marking in our Infineon Internet Page “Packages”: www.infineon.com/packages

5.4.1 Package Outline PG-TSSOP-38-9

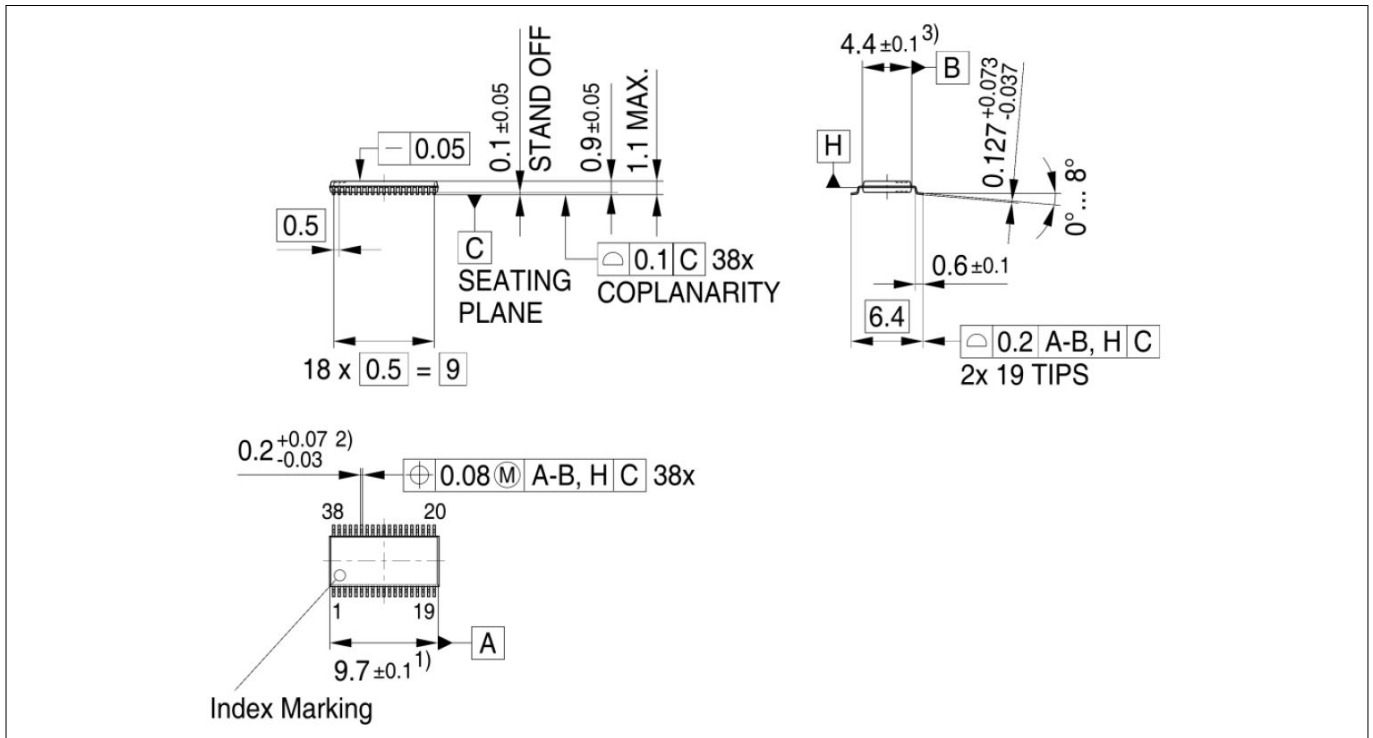

Figure 23 PG-TSSOP-38-9

5 Device and package specifications

5.4.2 Package Outline PG-VQFN-48-73

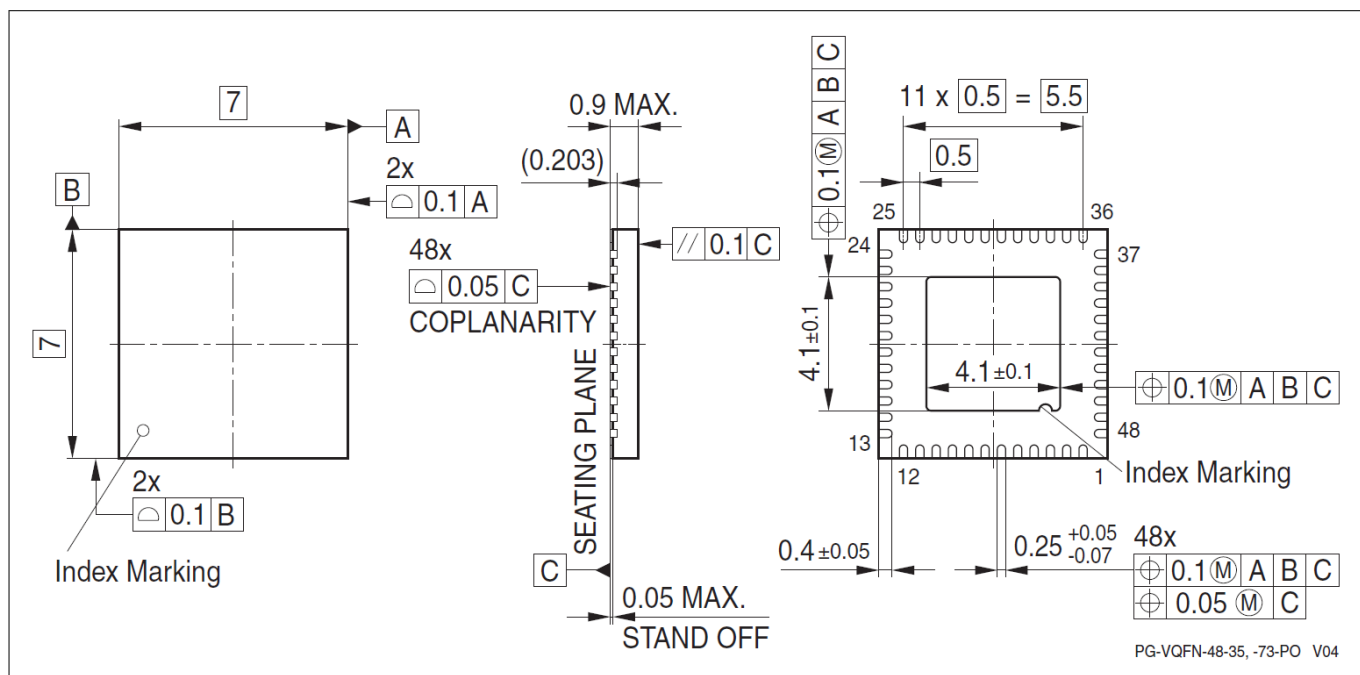

Figure 24 PG-VQFN-48-73

5 Device and package specifications

5.4.4 Package Outline PG-LQFP-64-26

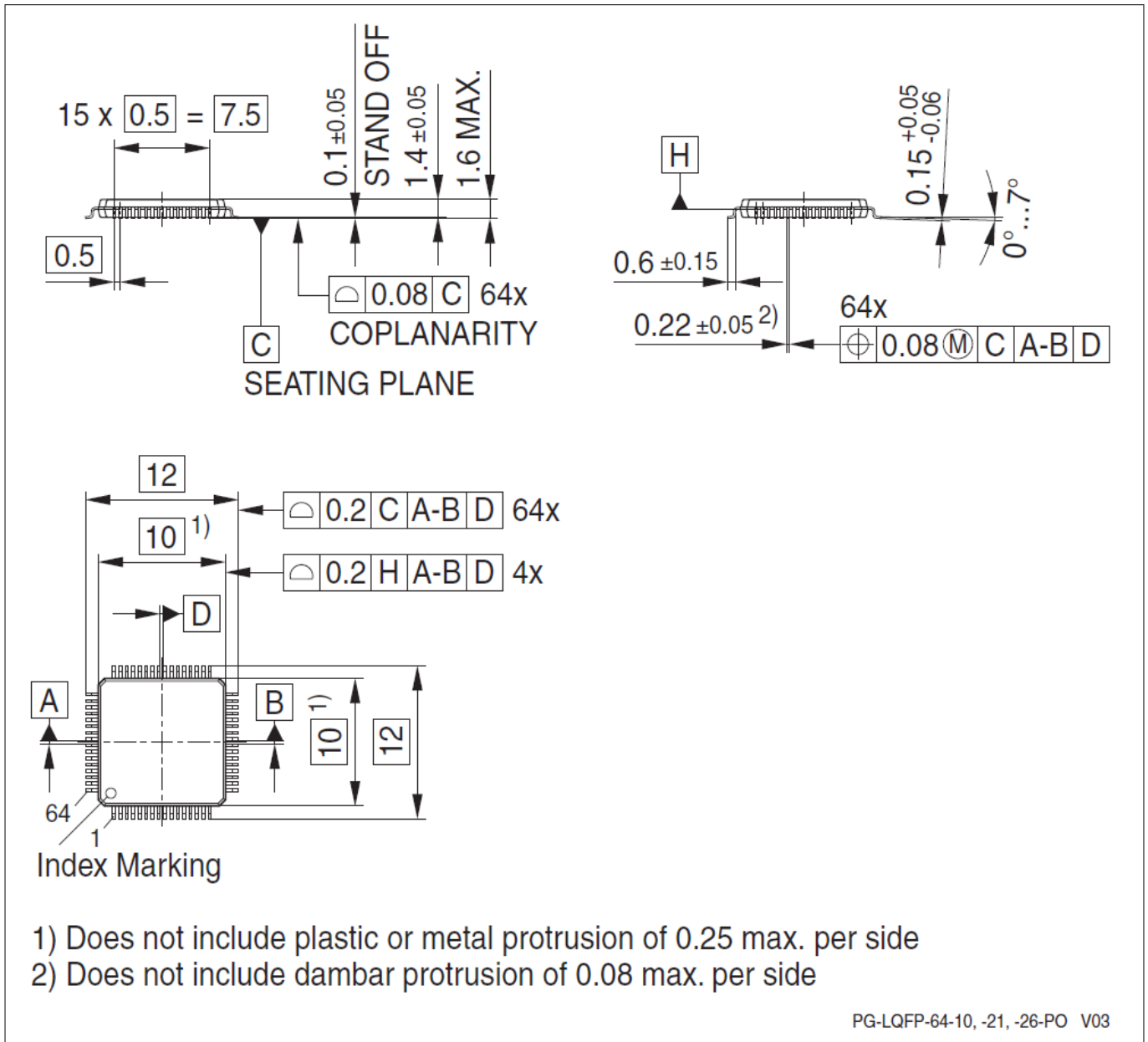

Figure 26 PG-LQFP-64-26

5 Device and package specifications

5.5 Part marking information

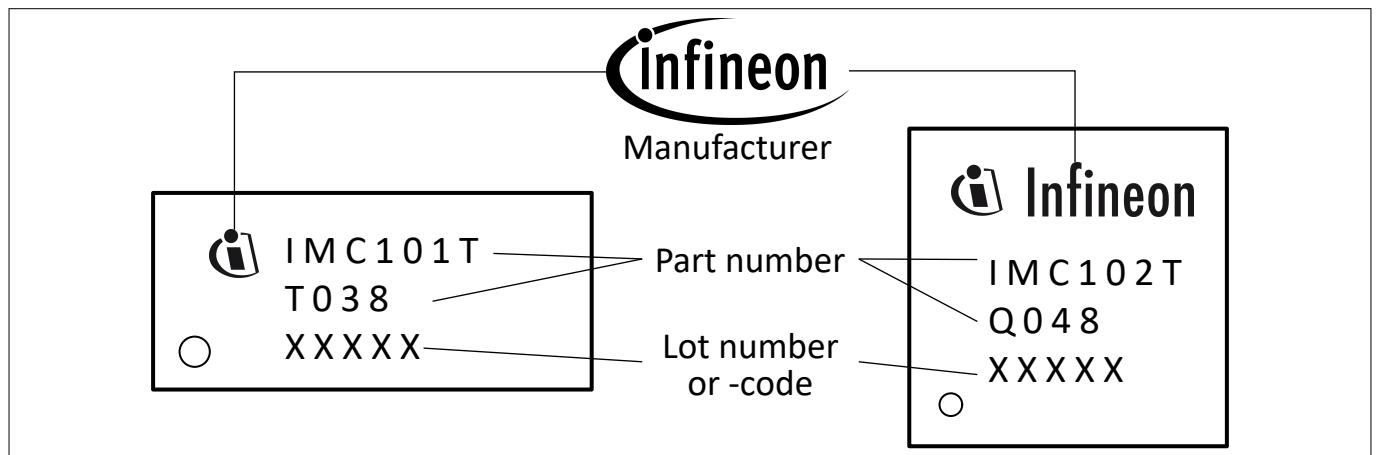

Figure 27 Part marking

Revision history

Revision history

Document version	Date of release	Description of changes
1.0	2018-02-09	<ul style="list-style-type: none">Initial version
1.1	2018-02-20	<ul style="list-style-type: none">Corrected RX1, TX1 in QFN-48, QFP-48 and LQFP-64
1.2	2018-07-24	<ul style="list-style-type: none">Added pins for scripting engineAdded SBSL-IDs and Chip-IDsAdded input voltage specificationSeveral minor corrections
1.3	2019-02-14	<ul style="list-style-type: none">Added the IMC099T-T038
1.4	2019-07-09	<ul style="list-style-type: none">Added IMC102T-F048, IMC102T-F048Corrected position of hall pinsCorrected min/max pin input voltageAdded GPIO16/GPIO17/GPIO18 to QFN-48 and QFP-48
1.5	2020-04-15	<ul style="list-style-type: none">Added clarification on DUTYFREQ vs. Hall sensor availabilityAdded DCO accuracy with calibrationIncreased maximum motor PWM to 40 kHz
1.6	2020-06-18	<ul style="list-style-type: none">Added GPIO6, GPIO7 to pin table for LQFP-48Corrected pin drawing for IMC101F-F048
1.7	2022-09-06	<ul style="list-style-type: none">Removed operating conditions for gate driver
1.8	2023-09-13	<ul style="list-style-type: none">New features pin mapping of TRIAC/I2C/IR added

Trademarks

All referenced product or service names and trademarks are the property of their respective owners.

Edition 2022-09-13

Published by

Infineon Technologies AG

81726 Munich, Germany

© 2023 Infineon Technologies AG

All Rights Reserved.

Do you have a question about any aspect of this document?

Email: erratum@infineon.com

Document reference

IFX-fbd1667478700210

Important notice

The information given in this document shall in no event be regarded as a guarantee of conditions or characteristics ("Beschaffheitsgarantie").

With respect to any examples, hints or any typical values stated herein and/or any information regarding the application of the product, Infineon Technologies hereby disclaims any and all warranties and liabilities of any kind, including without limitation warranties of non-infringement of intellectual property rights of any third party.

In addition, any information given in this document is subject to customer's compliance with its obligations stated in this document and any applicable legal requirements, norms and standards concerning customer's products and any use of the product of Infineon Technologies in customer's applications.

The data contained in this document is exclusively intended for technically trained staff. It is the responsibility of customer's technical departments to evaluate the suitability of the product for the intended application and the completeness of the product information given in this document with respect to such application.



Warnings

Due to technical requirements products may contain dangerous substances. For information on the types in question please contact your nearest Infineon Technologies office.







Except as otherwise explicitly approved by Infineon Technologies in a written document signed by authorized representatives of Infineon Technologies, Infineon Technologies' products may not be used in any applications where a failure of the product or any consequences of the use thereof can reasonably be expected to result in personal injury.

Looking for pricing, stock, or lifecycle information?

Click below to explore more details on WIN SOURCE:

-  [View IMC101TF048XUMA1 on WIN SOURCE](#)
-  [Infineon Technologies Information](#)

Optimize Your Supply Chain with WIN SOURCE Solutions

-  Global Sourcing Solution
-  Obsolete Management
-  Cost Control Management
-  Shortage Management
-  Alternative Solution
-  Excess Inventory Management