



**THE DATASHEET OF
NXS0102DC-Q100H**





NXS0102-Q100

Dual supply translating transceiver; open drain;
auto direction sensing

Rev. 3 — 16 November 2023

Product data sheet

1. General description

The NXS0102-Q100 is a 2-bit, dual supply translating transceiver with auto direction sensing, that enables bidirectional voltage level translation. It features two 2-bit input-output ports (An and Bn), one output enable input (OE) and two supply pins ($V_{CC(A)}$ and $V_{CC(B)}$). $V_{CC(A)}$ can be supplied at any voltage between 1.65 V and 3.6 V and $V_{CC(B)}$ can be supplied at any voltage between 2.3 V and 5.5 V, making the device suitable for translating between any of the voltage nodes (1.8 V, 2.5 V, 3.3 V and 5.0 V). Pins An and OE are referenced to $V_{CC(A)}$ and pins Bn are referenced to $V_{CC(B)}$. A LOW level at pin OE causes the outputs to assume a high-impedance OFF-state. This device is fully specified for partial power-down applications using I_{OFF} . The I_{OFF} circuitry disables the output, preventing the damaging backflow current through the device when it is powered down.

This product has been qualified to the Automotive Electronics Council (AEC) standard Q100 (Grade 1) and is suitable for use in automotive applications.

2. Features and benefits

- Automotive product qualification in accordance with AEC-Q100 (Grade 1)
 - Specified from -40 °C to +85 °C and from -40 °C to +125 °C
- Wide supply voltage range:
 - $V_{CC(A)}$: 1.65 V to 3.6 V and $V_{CC(B)}$: 2.3 V to 5.5 V
- Maximum data rates:
 - Push-pull: 24 Mbps
- I_{OFF} circuitry provides partial Power-down mode operation
- Inputs accept voltages up to 5.5 V
- Latch-up performance exceeds 100 mA per JESD 78B Class II
- ESD protection:
 - HBM: ANSI/ESDA/JEDEC JS-001 class 2 exceeds 2500 V for A port
 - HBM: ANSI/ESDA/JEDEC JS-001 class 3B exceeds 8000 V for B port
 - CDM: ANSI/ESDA/JEDEC JS-002 class C3 exceeds 1500 V

3. Applications

- Desktop PC
- Handset
- Smartphone
- Tablet

4. Ordering information

Table 1. Ordering information

Type number	Package			Version
	Temperature range	Name	Description	
NXS0102DC-Q100	-40 °C to +125 °C	VSSOP8	plastic very thin shrink small outline package; 8 leads; body width 2.3 mm	SOT765-1

5. Marking

Table 2. Marking

Type number	Marking code
NXS0102DC-Q100	m2

6. Functional diagram

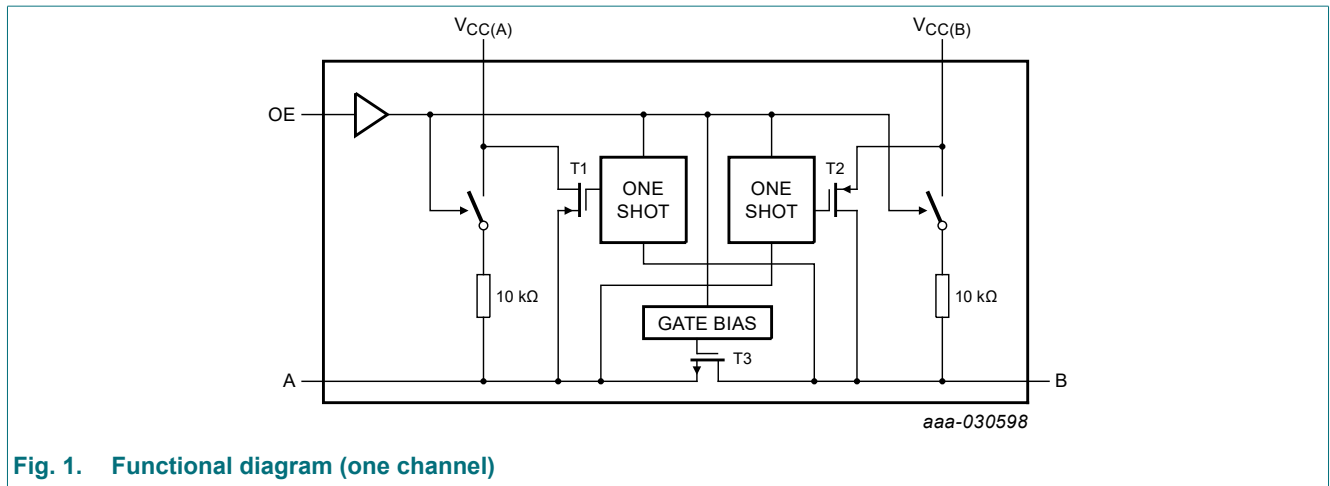
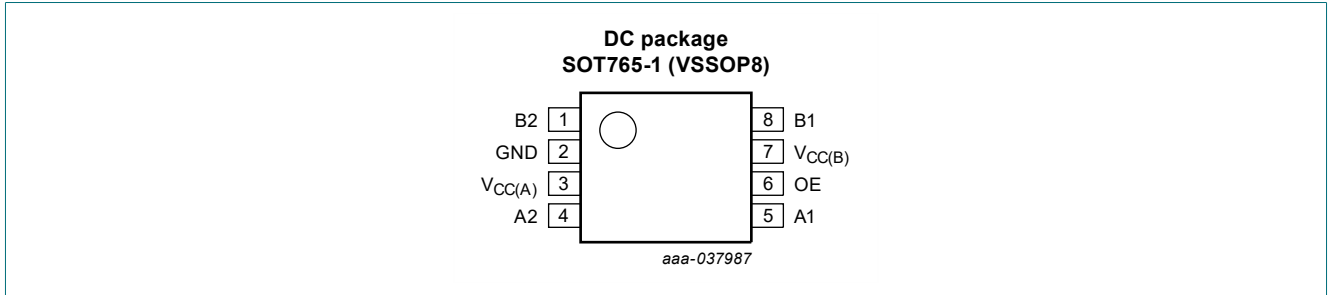

Fig. 1. Functional diagram (one channel)

7. Pinning information

7.1. Pinning



7.2. Pin description

Table 3. Pin description

Symbol	Pin	Description
B2, B1	1, 8	data input or output (referenced to $V_{CC(B)}$)
GND	2	ground (0 V)
$V_{CC(A)}$	3	supply voltage A
A2, A1	4, 5	data input or output (referenced to $V_{CC(A)}$)
OE	6	output enable input (active HIGH; referenced to $V_{CC(A)}$)
$V_{CC(B)}$	7	supply voltage B

8. Functional description

Table 4. Function table

H = HIGH voltage level; L = LOW voltage level; X = don't care; Z = high-impedance OFF-state.

Supply voltage		Input	Input/output	
$V_{CC(A)}$ [1]	$V_{CC(B)}$	OE	An	Bn
1.65 V to 3.6 V	2.3 V to 5.5 V	L	Z	Z
1.65 V to 3.6 V	2.3 V to 5.5 V	H	input or output	output or input
GND	2.3 V to 5.5 V	X	Z	Z
1.65 V to 3.6 V	GND	X	Z	Z

[1] $V_{CC(A)}$ must be less than or equal to $V_{CC(B)}$.

9. Limiting values

Table 5. Limiting values

In accordance with the Absolute Maximum Rating System (IEC 60134). Voltages are referenced to GND (ground = 0 V).

Symbol	Parameter	Conditions	Min	Max	Unit
$V_{CC(A)}$	supply voltage A		-0.5	+6.5	V
$V_{CC(B)}$	supply voltage B		-0.5	+6.5	V
V_I	input voltage	OE [1]	-0.5	+6.5	V
		Power-down or 3-state mode			
		A, B [1]	-0.5	+6.5	V
		Active mode			
		A, B [1] [2] [3]	-0.5	$V_{CCI} + 0.5$	V
V_O	output voltage	Power-down or 3-state mode			
		A, B [1]	-0.5	+6.5	V
		Active mode			
		A, B [1] [3] [4]	-0.5	$V_{CCO} + 0.5$	V
I_{IK}	input clamping current	$V_I < 0$ V	-50	-	mA
I_{OK}	output clamping current	$V_O < 0$ V	-50	-	mA
I_O	output current	$V_O = 0$ V to V_{CCO} [4]	-	± 50	mA
I_{CC}	supply current	$I_{CC(A)}$ or $I_{CC(B)}$	-	100	mA
I_{GND}	ground current		-100	-	mA
T_{stg}	storage temperature		-65	+150	°C
P_{tot}	total power dissipation	$T_{amb} = -40$ °C to +125 °C [5]	-	250	mW

[1] The minimum input and minimum output voltage ratings may be exceeded if the input and output current ratings are observed.

[2] V_{CCI} is the supply voltage associated with the input.

[3] $V_{CCI} + 0.5$ V or $V_{CCO} + 0.5$ V should not exceed 6.5 V.

[4] V_{CCO} is the supply voltage associated with the output.

[5] For SOT765-1 (VSSOP8) package: P_{tot} derates linearly with 4.9 mW/K above 99 °C.

10. Recommended operating conditions

Table 6. Recommended operating conditions [1] [2]

Symbol	Parameter	Conditions	Min	Max	Unit
$V_{CC(A)}$	supply voltage A		1.65	3.6	V
$V_{CC(B)}$	supply voltage B		2.3	5.5	V
V_I	input voltage	OE	0	5.5	V
		Power-down or 3-state mode			
		A	0	3.6	V
		B	0	5.5	V
		Active mode A, B [3]	0	V_{CCI}	V
V_O	output voltage	Power-down or 3-state mode			
		A	0	3.6	V
		B	0	5.5	V
		Active mode A, B [4]	0	V_{CCO}	V
		T_{amb}	ambient temperature		-40
$\Delta t/\Delta V$	input transition rise and fall rate	A or B port; push-pull driving			
		$V_{CC(A)} = 1.65\text{ V to }3.6\text{ V};$ $V_{CC(B)} = 2.3\text{ V to }5.5\text{ V}$	-	10	ns/V
		OE input			
		$V_{CC(A)} = 1.65\text{ V to }3.6\text{ V};$ $V_{CC(B)} = 2.3\text{ V to }5.5\text{ V}$	-	10	ns/V

[1] The A and B sides of an unused I/O pair must be held in the same state, both at V_{CCI} or both at GND.

[2] $V_{CC(A)}$ must be less than or equal to $V_{CC(B)}$.

[3] V_{CCI} is the supply voltage associated with the input.

[4] V_{CCO} is the supply voltage associated with the output.

11. Static characteristics

Table 7. Typical static characteristics

At recommended operating conditions; voltages are referenced to GND (ground = 0 V); $T_{amb} = 25\text{ }^{\circ}\text{C}$. [1]

Symbol	Parameter	Conditions	Min	Typ	Max	Unit
I_I	input leakage current	OE input; $V_{CC(A)} = 1.65\text{ V to }3.6\text{ V}$; $V_{CC(B)} = 2.3\text{ V to }5.5\text{ V}$	-	-	± 1	μA
I_{OZ}	OFF-state output current	A or B port; $V_{CC(A)} = 1.65\text{ V to }3.6\text{ V}$; $V_{CC(B)} = 2.3\text{ V to }5.5\text{ V}$; $OE = 0\text{ V}$	-	-	± 1	μA
I_{OFF}	power-off leakage current	A port; $V_{CC(A)} = 0\text{ V}$; $V_{CC(B)} = 0\text{ V to }5.5\text{ V}$	-	-	± 1	μA
		B port; $V_{CC(B)} = 0\text{ V}$; $V_{CC(A)} = 0\text{ V to }3.6\text{ V}$	-	-	± 1	μA
C_I	input capacitance	OE input; $V_{CC(A)} = 3.3\text{ V}$; $V_{CC(B)} = 3.3\text{ V}$	-	2.0	-	pF
$C_{I/O}$	input/output capacitance	A port; $V_{CC(A)} = 3.3\text{ V}$; $V_{CC(B)} = 3.3\text{ V}$				
		enabled	-	10	-	pF
		disabled	-	4	-	pF
		B port; $V_{CC(A)} = 3.3\text{ V}$; $V_{CC(B)} = 3.3\text{ V}$				
		enabled	-	10	-	pF
	disabled	-	7	-	pF	

[1] $V_{CC(A)}$ must be less than or equal to $V_{CC(B)}$.

Table 8. Typical supply current

At recommended operating conditions; voltages are referenced to GND (ground = 0 V); $T_{amb} = 25\text{ }^{\circ}\text{C}$.

$V_{CC(A)}$	$V_{CC(B)}$						Unit
	2.5 V		3.3 V		5.0 V		
	$I_{CC(A)}$	$I_{CC(B)}$	$I_{CC(A)}$	$I_{CC(B)}$	$I_{CC(A)}$	$I_{CC(B)}$	
1.8 V	0.1	0.5	0.1	1.5	0.1	4.6	μA
2.5 V	0.1	0.1	0.1	0.8	0.1	3.8	μA
3.3 V	-	-	0.1	0.1	0.1	2.8	μA

Dual supply translating transceiver; open drain; auto direction sensing

Table 9. Static characteristics

At recommended operating conditions; voltages are referenced to GND (ground = 0 V).[1]

Symbol	Parameter	Conditions	-40 °C to +85 °C		-40 °C to +125 °C		Unit
			Min	Max	Min	Max	
V _{IH}	HIGH-level input voltage	A port					
		V _{CC(A)} = 1.65 V to 1.95 V; V _{CC(B)} = 2.3 V to 5.5 V	V _{CC(A)} - 0.2	V _{CC(A)}	V _{CC(A)} - 0.2	V _{CC(A)}	V
		V _{CC(A)} = 2.3 V to 3.6 V; V _{CC(B)} = 2.3 V to 5.5 V	V _{CC(A)} - 0.4	V _{CC(A)}	V _{CC(A)} - 0.4	V _{CC(A)}	V
		B port					
		V _{CC(A)} = 1.65 V to 3.6 V; V _{CC(B)} = 2.3 V to 5.5 V	V _{CC(B)} - 0.4	V _{CC(B)}	V _{CC(B)} - 0.4	V _{CC(B)}	V
		OE input					
		V _{CC(A)} = 1.65 V to 3.6 V; V _{CC(B)} = 2.3 V to 5.5 V	0.65V _{CC(A)}	V _{CC(A)}	0.65V _{CC(A)}	V _{CC(A)}	V
V _{IL}	LOW-level input voltage	A or B port					
		V _{CC(A)} = 1.65 V to 3.6 V; V _{CC(B)} = 2.3 V to 5.5 V	0	0.15	0	0.15	V
		OE input					
		V _{CC(A)} = 1.65 V to 3.6 V; V _{CC(B)} = 2.3 V to 5.5 V	0	0.35V _{CC(A)}	0	0.35V _{CC(A)}	V
V _{OH}	HIGH-level output voltage	A port; I _O = -20 μA; V _I ≥ V _{CC(B)} - 0.4 V					
		V _{CC(A)} = 1.65 V to 3.6 V; V _{CC(B)} = 2.3 V to 5.5 V	0.67V _{CC(A)}	-	0.67V _{CC(A)}	-	V
		B port; I _O = -20 μA; V _I ≥ V _{CC(A)} - 0.2 V					
		V _{CC(A)} = 1.65 V to 3.6 V; V _{CC(B)} = 2.3 V to 5.5 V	0.67V _{CC(B)}	-	0.67V _{CC(B)}	-	V
V _{OL}	LOW-level output voltage	A or B port; I _O = 1 mA; V _I ≤ 0.15 V					
		V _{CC(A)} = 1.65 V to 3.6 V; V _{CC(B)} = 2.3 V to 5.5 V	-	0.4	-	0.4	V
I _I	input leakage current	OE input; V _{CC(A)} = 1.65 V to 3.6 V; V _{CC(B)} = 2.3 V to 5.5 V	-	±2	-	±12	μA
I _{OZ}	OFF-state output current	A or B port; V _{CC(A)} = 1.65 V to 3.6 V; V _{CC(B)} = 2.3 V to 5.5 V	-	±2	-	±12	μA
I _{OFF}	power-off leakage current	A port; V _{CC(A)} = 0 V; V _{CC(B)} = 0 V to 5.5 V	-	±2	-	±12	μA
		B port; V _{CC(B)} = 0 V; V _{CC(A)} = 0 V to 3.6 V	-	±2	-	±12	μA

Dual supply translating transceiver; open drain; auto direction sensing

Symbol	Parameter	Conditions	-40 °C to +85 °C		-40 °C to +125 °C		Unit
			Min	Max	Min	Max	
I _{CC}	supply current	OE = 0 V or V _{CC(A)} ; An, Bn open					
		I _{CC(A)}					
		V _{CC(A)} = 1.65 V to 3.6 V; V _{CC(B)} = 2.3 V to 5.5 V	-	2.4	-	15	μA
		V _{CC(A)} = 3.6 V; V _{CC(B)} = 0 V	-	2.2	-	15	μA
		V _{CC(A)} = 0 V; V _{CC(B)} = 5.5 V	-	-1	-	-8	μA
		I _{CC(B)}					
		V _{CC(A)} = 1.65 V to 3.6 V; V _{CC(B)} = 2.3 V to 5.5 V	-	12	-	30	μA
		V _{CC(A)} = 3.6 V; V _{CC(B)} = 0 V	-	-1	-	-5	μA
		V _{CC(A)} = 0 V; V _{CC(B)} = 5.5 V	-	1	-	6	μA
		I _{CC(A)} + I _{CC(B)}					
V _{CC(A)} = 1.65 V to 3.6 V; V _{CC(B)} = 2.3 V to 5.5 V	-	14.4	-	30	μA		

[1] V_{CC(A)} must be less than or equal to V_{CC(B)} and V_{CC(A)} must not exceed 3.6 V.

12. Dynamic characteristics

Table 10. Dynamic characteristics for temperature range -40 °C to +85 °C

Voltages are referenced to GND (ground = 0 V); for test circuit see Fig. 5; for waveforms see Fig. 2 to Fig. 4.

Symbol	Parameter	Conditions	V _{CC(B)}						Unit
			2.5 V ± 0.2 V		3.3 V ± 0.3 V		5.0 V ± 0.5 V		
			Min	Max	Min	Max	Min	Max	
V_{CC(A)} = 1.8 V ± 0.15 V									
t _{PHL}	HIGH to LOW propagation delay	A to B	-	5.3	-	5.4	-	6.8	ns
t _{PLH}	LOW to HIGH propagation delay	A to B	-	7.1	-	7.1	-	7.5	ns
t _{PHL}	HIGH to LOW propagation delay	B to A	-	4.4	-	4.5	-	4.7	ns
t _{PLH}	LOW to HIGH propagation delay	B to A	-	5.3	-	4.5	-	0.5	ns
t _{en}	enable time	OE to A, B	-	200	-	200	-	200	ns
t _{dis}	disable time	OE to A, B; no external load [1] [2]	-	35	-	35	-	35	ns
		OE to A	-	140	-	140	-	145	ns
		OE to B	-	125	-	175	-	125	ns
t _{TLH}	LOW to HIGH output transition time	A port	3.2	9.5	2.3	9.3	1.8	7.6	ns
		B port	3.3	10.8	2.7	9.1	2.7	7.6	ns
t _{THL}	HIGH to LOW output transition time	A port	2.0	5.9	1.9	6.0	1.7	13.3	ns
		B port	2.9	7.6	2.8	7.9	2.8	10.5	ns
t _{sk(o)}	output skew time	between channels [3]	-	0.7	-	0.7	-	0.7	ns
t _W	pulse width	data inputs	41	-	41	-	41	-	ns
f _{data}	data rate		-	24	-	24	-	24	Mbps

Dual supply translating transceiver; open drain; auto direction sensing

Symbol	Parameter	Conditions	$V_{CC(B)}$						Unit
			$2.5\text{ V} \pm 0.2\text{ V}$		$3.3\text{ V} \pm 0.3\text{ V}$		$5.0\text{ V} \pm 0.5\text{ V}$		
			Min	Max	Min	Max	Min	Max	
$V_{CC(A)} = 2.5\text{ V} \pm 0.2\text{ V}$									
t_{PHL}	HIGH to LOW propagation delay	A to B	-	3.2	-	3.7	-	3.8	ns
t_{PLH}	LOW to HIGH propagation delay	A to B	-	3.5	-	4.4	-	4.6	ns
t_{PHL}	HIGH to LOW propagation delay	B to A	-	3.0	-	3.6	-	4.3	ns
t_{PLH}	LOW to HIGH propagation delay	B to A	-	2.5	-	1.6	-	1.0	ns
t_{en}	enable time	OE to A, B	-	200	-	200	-	200	ns
t_{dis}	disable time	OE to A, B; no external load [1] [2]	-	35	-	35	-	35	ns
		OE to A	-	105	-	105	-	105	ns
		OE to B	-	125	-	175	-	120	ns
t_{TLH}	LOW to HIGH output transition time	A port	2.8	7.5	2.6	6.6	1.8	6.5	ns
		B port	3.2	8.5	2.9	7.9	2.4	6.8	ns
t_{THL}	HIGH to LOW output transition time	A port	1.9	5.7	1.9	5.5	1.8	5.3	ns
		B port	2.2	7.8	2.4	6.7	2.6	6.9	ns
$t_{sk(o)}$	output skew time	between channels [3]	-	0.7	-	0.7	-	0.7	ns
t_W	pulse width	data inputs	41	-	41	-	41	-	ns
f_{data}	data rate		-	24	-	24	-	24	Mbps
$V_{CC(A)} = 3.3\text{ V} \pm 0.3\text{ V}$									
t_{PHL}	HIGH to LOW propagation delay	A to B	-	-	-	2.4	-	3.1	ns
t_{PLH}	LOW to HIGH propagation delay	A to B	-	-	-	4.2	-	4.4	ns
t_{PHL}	HIGH to LOW propagation delay	B to A	-	-	-	2.5	-	3.3	ns
t_{PLH}	LOW to HIGH propagation delay	B to A	-	-	-	2.5	-	2.6	ns
t_{en}	enable time	OE to A, B	-	-	-	200	-	200	ns
t_{dis}	disable time	OE to A, B; no external load [1] [2]	-	-	-	35	-	35	ns
		OE to A	-	-	-	150	-	150	ns
		OE to B	-	-	-	170	-	120	ns
t_{TLH}	LOW to HIGH output transition time	A port	-	-	2.3	6.2	1.9	6.3	ns
		B port	-	-	2.5	6.9	2.1	7.4	ns
t_{THL}	HIGH to LOW output transition time	A port	-	-	2.0	5.4	1.9	5.0	ns
		B port	-	-	2.3	7.4	2.4	7.6	ns
$t_{sk(o)}$	output skew time	between channels [3]	-	-	-	0.7	-	0.7	ns
t_W	pulse width	data inputs	-	-	41	-	41	-	ns
f_{data}	data rate		-	-	-	24	-	24	Mbps

[1] t_{dis} is the same as t_{PLZ} and t_{PHZ} .

[2] The disable time with no external load indicates the delay between when OE goes LOW and when outputs actually become disabled.

[3] Skew between any two outputs of the same package switching in the same direction.

Dual supply translating transceiver; open drain; auto direction sensing

Table 11. Dynamic characteristics for temperature range -40 °C to +125 °C

Voltages are referenced to GND (ground = 0 V); for test circuit see Fig. 5; for waveforms see Fig. 2 to Fig. 4.

Symbol	Parameter	Conditions	V _{CC(B)}						Unit
			2.5 V ± 0.2 V		3.3 V ± 0.3 V		5.0 V ± 0.5 V		
			Min	Max	Min	Max	Min	Max	
V_{CC(A)} = 1.8 V ± 0.15 V									
t _{PHL}	HIGH to LOW propagation delay	A to B	-	5.8	-	5.9	-	7.3	ns
t _{PLH}	LOW to HIGH propagation delay	A to B	-	8.5	-	8.5	-	8.8	ns
t _{PHL}	HIGH to LOW propagation delay	B to A	-	5.5	-	5.7	-	5.9	ns
t _{PLH}	LOW to HIGH propagation delay	B to A	-	6.7	-	5.7	-	0.7	ns
t _{en}	enable time	OE to A, B	-	200	-	200	-	200	ns
t _{dis}	disable time	OE to A, B; no external load [1] [2]	-	45	-	45	-	45	ns
		OE to A	-	140	-	140	-	145	ns
		OE to B	-	125	-	175	-	125	ns
t _{TLH}	LOW to HIGH output transition time	A port	3.2	11.9	2.3	11.7	1.8	9.5	ns
		B port	3.3	13.5	2.7	11.4	2.7	9.5	ns
t _{THL}	HIGH to LOW output transition time	A port	2.0	7.4	1.9	7.5	1.7	16.7	ns
		B port	2.9	9.5	2.8	9.4	2.8	12.5	ns
t _{sk(o)}	output skew time	between channels [3]	-	0.8	-	0.8	-	0.8	ns
t _W	pulse width	data inputs	50	-	41	-	41	-	ns
f _{data}	data rate		-	20	-	24	-	24	Mbps
V_{CC(A)} = 2.5 V ± 0.2 V									
t _{PHL}	HIGH to LOW propagation delay	A to B	-	4.0	-	4.2	-	4.3	ns
t _{PLH}	LOW to HIGH propagation delay	A to B	-	4.4	-	5.2	-	5.5	ns
t _{PHL}	HIGH to LOW propagation delay	B to A	-	3.8	-	4.5	-	5.4	ns
t _{PLH}	LOW to HIGH propagation delay	B to A	-	3.2	-	2.0	-	0.9	ns
t _{en}	enable time	OE to A, B	-	200	-	200	-	200	ns
t _{dis}	disable time	OE to A, B; no external load [1] [2]	-	45	-	45	-	45	ns
		OE to A	-	105	-	105	-	105	ns
		OE to B	-	125	-	175	-	120	ns
t _{TLH}	LOW to HIGH output transition time	A port	2.8	9.3	2.6	8.3	1.8	7.8	ns
		B port	3.2	10.4	2.9	9.7	2.4	8.3	ns
t _{THL}	HIGH to LOW output transition time	A port	1.9	7.2	1.9	6.9	1.8	6.7	ns
		B port	2.2	9.8	2.4	8.4	2.6	8.3	ns
t _{sk(o)}	output skew time	between channels [3]	-	0.8	-	0.8	-	0.8	ns
t _W	pulse width	data inputs	50	-	41	-	41	-	ns
f _{data}	data rate		-	20	-	24	-	24	Mbps

Dual supply translating transceiver; open drain; auto direction sensing

Symbol	Parameter	Conditions	V _{CC(B)}						Unit
			2.5 V ± 0.2 V		3.3 V ± 0.3 V		5.0 V ± 0.5 V		
			Min	Max	Min	Max	Min	Max	
V_{CC(A)} = 3.3 V ± 0.3 V									
t _{PHL}	HIGH to LOW propagation delay	A to B	-	-	-	3.0	-	3.9	ns
t _{PLH}	LOW to HIGH propagation delay	A to B	-	-	-	5.3	-	5.5	ns
t _{PHL}	HIGH to LOW propagation delay	B to A	-	-	-	3.2	-	4.2	ns
t _{PLH}	LOW to HIGH propagation delay	B to A	-	-	-	3.2	-	3.3	ns
t _{en}	enable time	OE to A, B	-	-	-	200	-	200	ns
t _{dis}	disable time	OE to A, B; no external load [1] [2]	-	-	-	45	-	45	ns
		OE to A	-	-	-	150	-	150	ns
		OE to B	-	-	-	170	-	120	ns
t _{TLH}	LOW to HIGH output transition time	A port	-	-	2.3	7.0	1.9	7.4	ns
		B port	-	-	2.5	8.0	2.1	9.3	ns
t _{THL}	HIGH to LOW output transition time	A port	-	-	2.0	6.8	1.9	6.3	ns
		B port	-	-	2.3	9.3	2.4	9.5	ns
t _{sk(o)}	output skew time	between channels [3]	-	-	-	0.8	-	0.8	ns
t _W	pulse width	data inputs	-	-	41	-	41	-	ns
f _{data}	data rate		-	-	-	24	-	24	Mbps

- [1] t_{dis} is the same as t_{PLZ} and t_{PHZ}.
- [2] The disable time with no external load indicates the delay between when OE goes LOW and when outputs actually become disabled.
- [3] Skew between any two outputs of the same package switching in the same direction.

12.1. Waveforms and test circuit

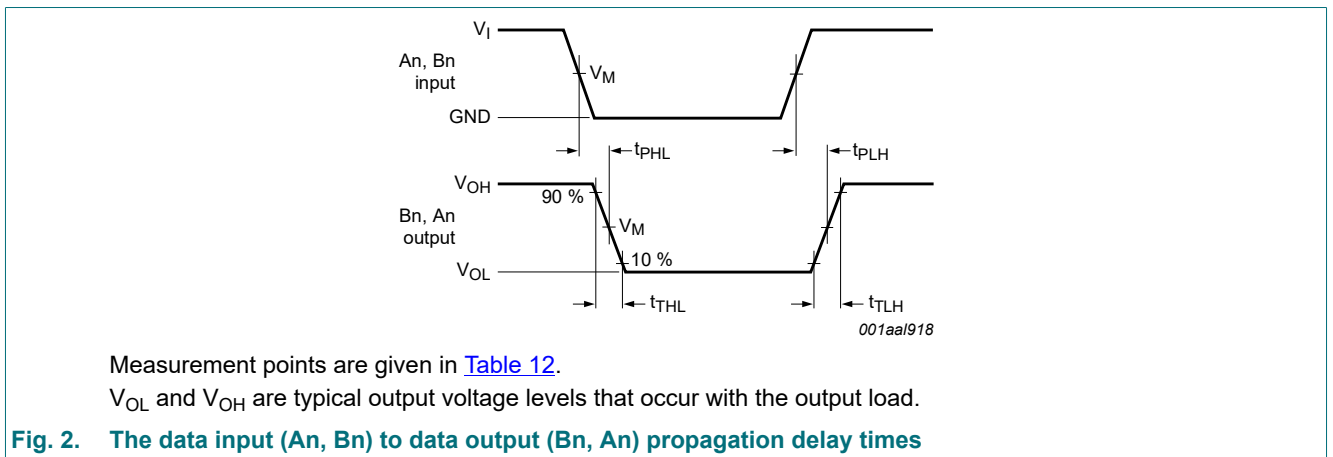

Dual supply translating transceiver; open drain; auto direction sensing

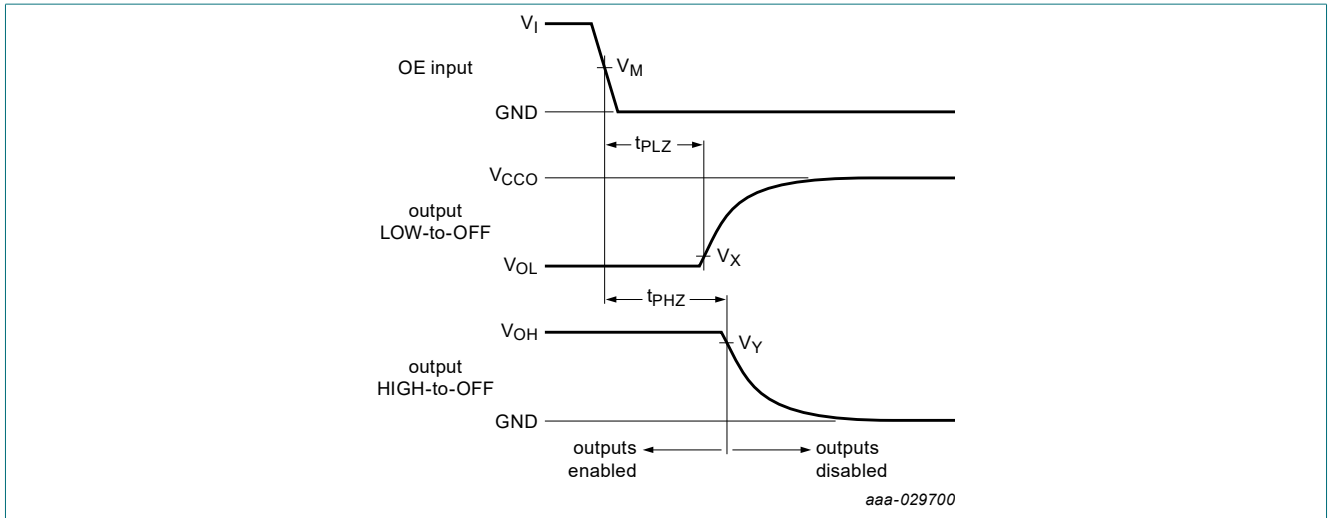

Measurement points are given in [Table 12](#).
 V_{OL} and V_{OH} are typical output voltage levels that occur with the output load.
 V_{CCO} is the supply voltage associated with the output.

Fig. 3. Disable times

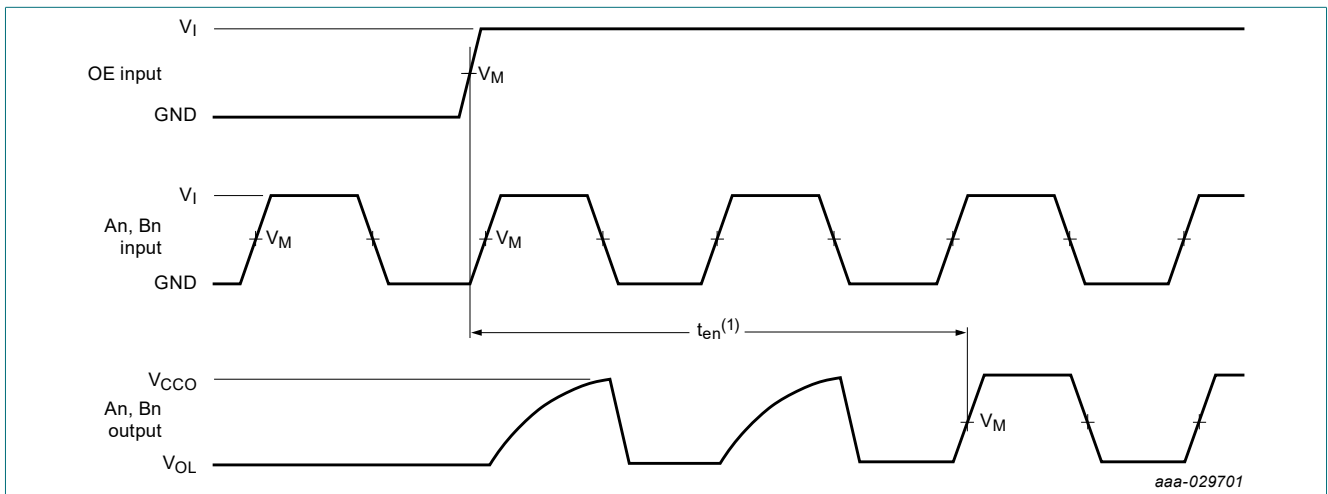

(1) The enable time (t_{en}) indicates the amount of time the user must allow for one one-shot circuitry to become operational after OE is taken HIGH. See also [Section 13.6](#).
 Measurement points are given in [Table 12](#).
 V_{OL} is a typical output voltage level that occur with the output load.
 V_{CCO} is the supply voltage associated with the output.

Fig. 4. Enable times

Table 12. Measurement points

Supply voltage	Input	Output		
V_{CCO}	V_M [1]	V_M [2]	V_X	V_Y
1.8 V ± 0.15 V	0.5 V_{CCI}	0.5 V_{CCO}	$V_{OL} + 0.15$ V	$V_{OH} - 0.15$ V
2.5 V ± 0.2 V	0.5 V_{CCI}	0.5 V_{CCO}	$V_{OL} + 0.15$ V	$V_{OH} - 0.15$ V
3.3 V ± 0.3 V	0.5 V_{CCI}	0.5 V_{CCO}	$V_{OL} + 0.3$ V	$V_{OH} - 0.3$ V
5.0 V ± 0.5 V	0.5 V_{CCI}	0.5 V_{CCO}	$V_{OL} + 0.3$ V	$V_{OH} - 0.3$ V

[1] V_{CCI} is the supply voltage associated with the input.
 [2] V_{CCO} is the supply voltage associated with the output.

Dual supply translating transceiver; open drain; auto direction sensing

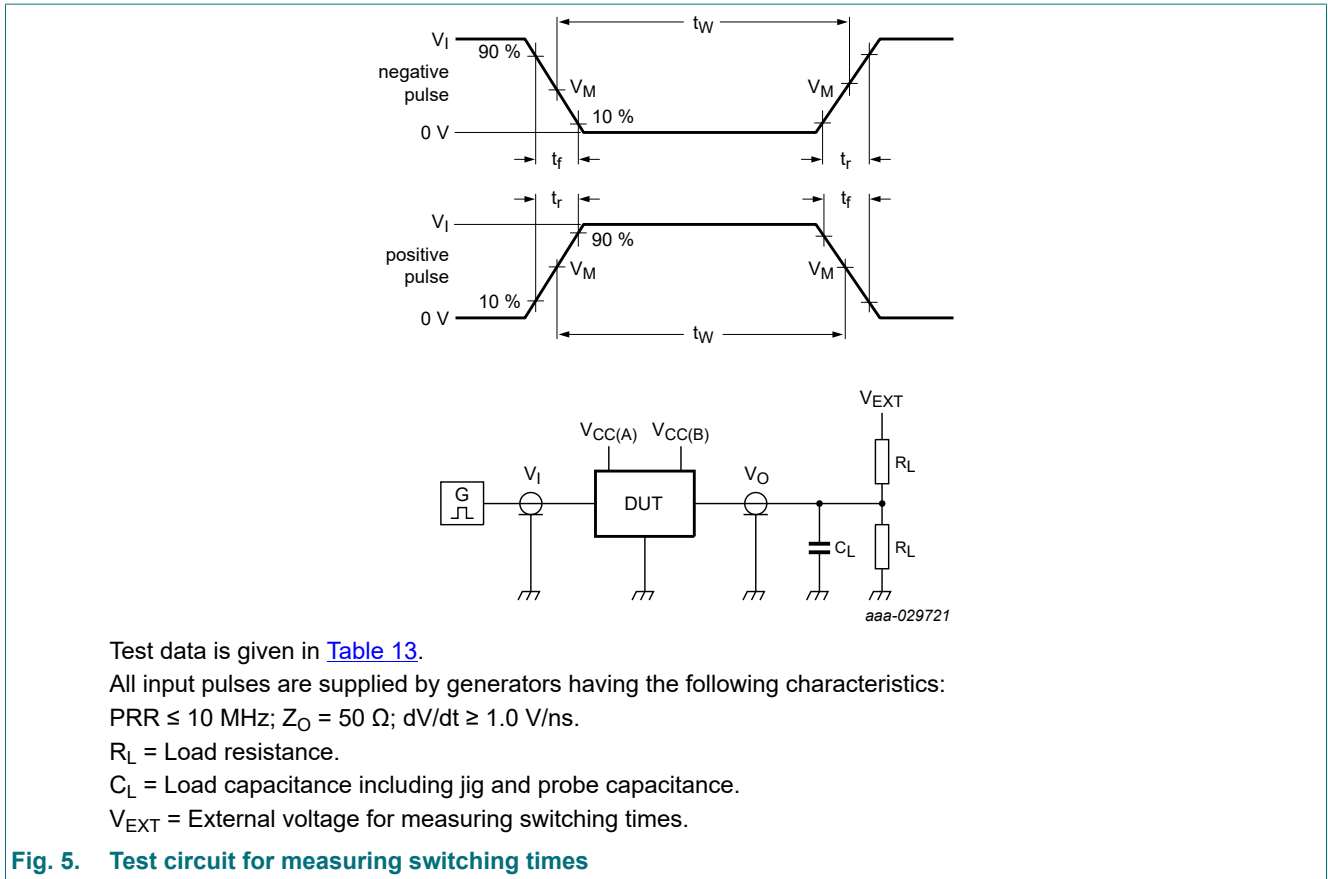

Table 13. Test data

Supply voltage		Input		Load		V_{EXT}		
$V_{CC(A)}$	$V_{CC(B)}$	V_I [1]	$\Delta t/\Delta V$	C_L	R_L [2]	t_{PLH} , t_{PHL}	t_{PZH} , t_{PHZ}	t_{PZL} , t_{PLZ} [3]
1.65 V to 3.6 V	2.3 V to 5.5 V	V_{CCI}	$\leq 1.0 \text{ ns/V}$	15 pF	50 k Ω , 1 M Ω	open	open	$2V_{CCO}$

- [1] V_{CCI} is the supply voltage associated with the input.
- [2] For measuring data rate, pulse width, propagation delay and output rise and fall measurements, $R_L = 1 \text{ M}\Omega$;
 for measuring enable and disable times, $R_L = 50 \text{ k}\Omega$.
- [3] V_{CCO} is the supply voltage associated with the output.

13. Application information

13.1. Applications

Voltage level-translation applications. The NXS0102-Q100 can be used in point-to-point applications to interface between devices or systems operating at different supply voltages. The device is primarily targeted at I²C or 1-wire which use open-drain drivers, it may also be used in applications where push-pull drivers are connected to the ports, however the NXB0102-Q100 may be more suitable.

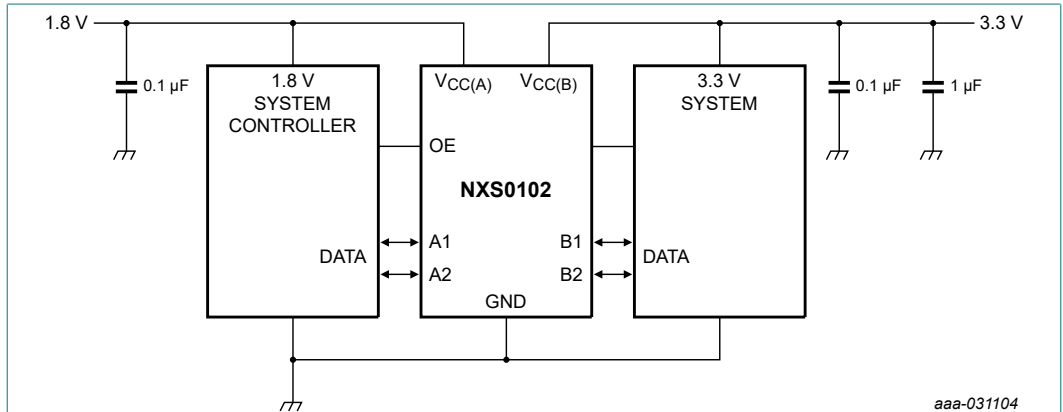

Fig. 6. Typical operating circuit

13.2. Architecture

The architecture of the NXS0102-Q100 is shown in Fig. 7. The device does not require an extra input signal to control the direction of data flow from A to B or B to A.

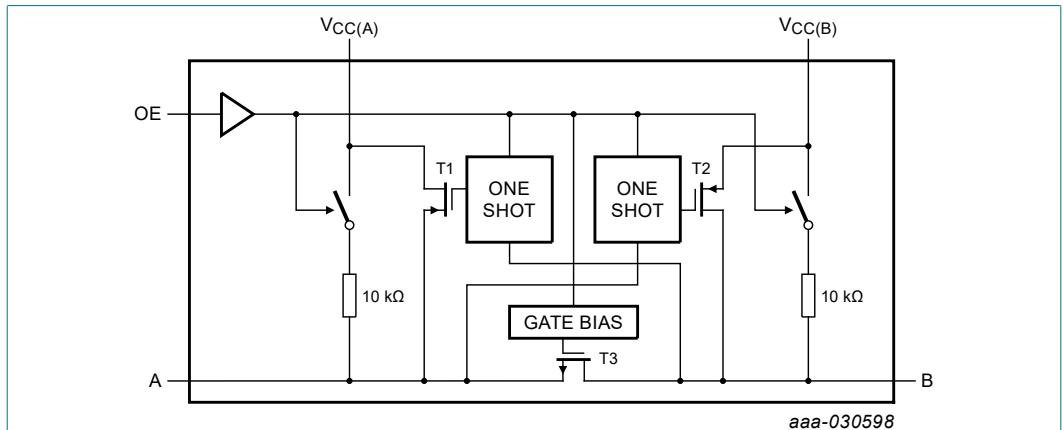

Fig. 7. Architecture of NXS0102-Q100 I/O cell (one channel)

The NXS0102-Q100 is a "switch" type voltage translator, it employs two key circuits to enable voltage translation:

1. A pass-gate transistor (N-channel) that ties the ports together.
2. An output edge-rate accelerator that detects and accelerates rising edges on the I/O pins.

The gate bias voltage of the pass gate transistor (T3) is set at approximately one threshold voltage above the $V_{CC(A)}$ level of the low-voltage side. During a rising edge, the one shots turn on the PMOS transistors (T1, T2) for a short duration, accelerating the low-to-high transition. The one-shot is activated once the input transition reaches approximately $0.5V_{CC1}$. During the acceleration time the driver output resistance is between approximately 50 Ω and 70 Ω. To avoid signal contention

Dual supply translating transceiver; open drain; auto direction sensing

and minimize dynamic I_{CC} , the user should wait for the one-shot circuit to turn-off before applying a signal in the opposite direction. Pull-up resistors are included in the device for DC current sourcing capability.

13.3. Input driver requirements

As the NXS0102-Q100 is a switch type translator, properties of the input driver directly effect the output signal. The external open-drain or push-pull driver applied to an I/O determines the static current sinking capability of the system. The max data rate, HIGH-to-LOW output transition time (t_{THL}) and propagation delay (t_{PHL}) are dependent upon the output impedance and edge-rate of the external driver. The limits provided for these parameters in the datasheet assume a driver with output impedance below $50\ \Omega$ is used.

13.4. Output load considerations

The maximum lumped capacitive load that can be driven is dependant upon the one-shot pulse duration. In cases with very heavy capacitive loading there is a risk that the output will not reach the positive rail within the one-shot pulse duration. To avoid excessive capacitive loading and to ensure correct triggering of the one-shot it's recommended to use short trace lengths and low capacitance connectors on NXS0102-Q100 PCB layouts. To ensure low impedance termination and avoid output signal oscillations and one-shot re-triggering, the length of the PCB trace should be such that the round trip delay of any reflection is within the one-shot pulse duration.

13.5. Power up

During operation $V_{CC(A)}$ must never be higher than $V_{CC(B)}$, however during power-up $V_{CC(A)} \geq V_{CC(B)}$ does not damage the device, so any power supply can be ramped up first. There is no special power-up sequencing required. The NXS0102-Q100 includes circuitry that disables all output ports when either $V_{CC(A)}$ or $V_{CC(B)}$ is switched off.

13.6. Enable and disable

An output enable input (OE) is used to disable the device. Setting OE to LOW causes all I/Os to assume the high-impedance OFF-state. The disable time (t_{dis} with no external load) indicates the delay between when OE goes LOW and when outputs actually become disabled. The enable time (t_{en}) indicates the amount of time the user must allow for one one-shot circuitry to become operational after OE is taken HIGH. To ensure the high-impedance OFF-state during power-up or power-down, pin OE should be tied to GND through a pull-down resistor, the minimum value of the resistor is determined by the current-sourcing capability of the driver.

13.7. Pull-up or pull-down resistors on I/O lines

Each A port I/O has an internal $10\ k\Omega$ pull-up resistor to $V_{CC(A)}$, and each B port I/O has an internal $10\ k\Omega$ pull-up resistor to $V_{CC(B)}$. If a smaller value of pull-up resistor is required, an external resistor must be added parallel to the internal $10\ k\Omega$, this will effect the V_{OL} level. When OE goes LOW the internal pull-ups of the NXS0102-Q100 are disabled.

14. Package outline

VSSOP8: plastic very thin shrink small outline package; 8 leads; body width 2.3 mm

SOT765-1

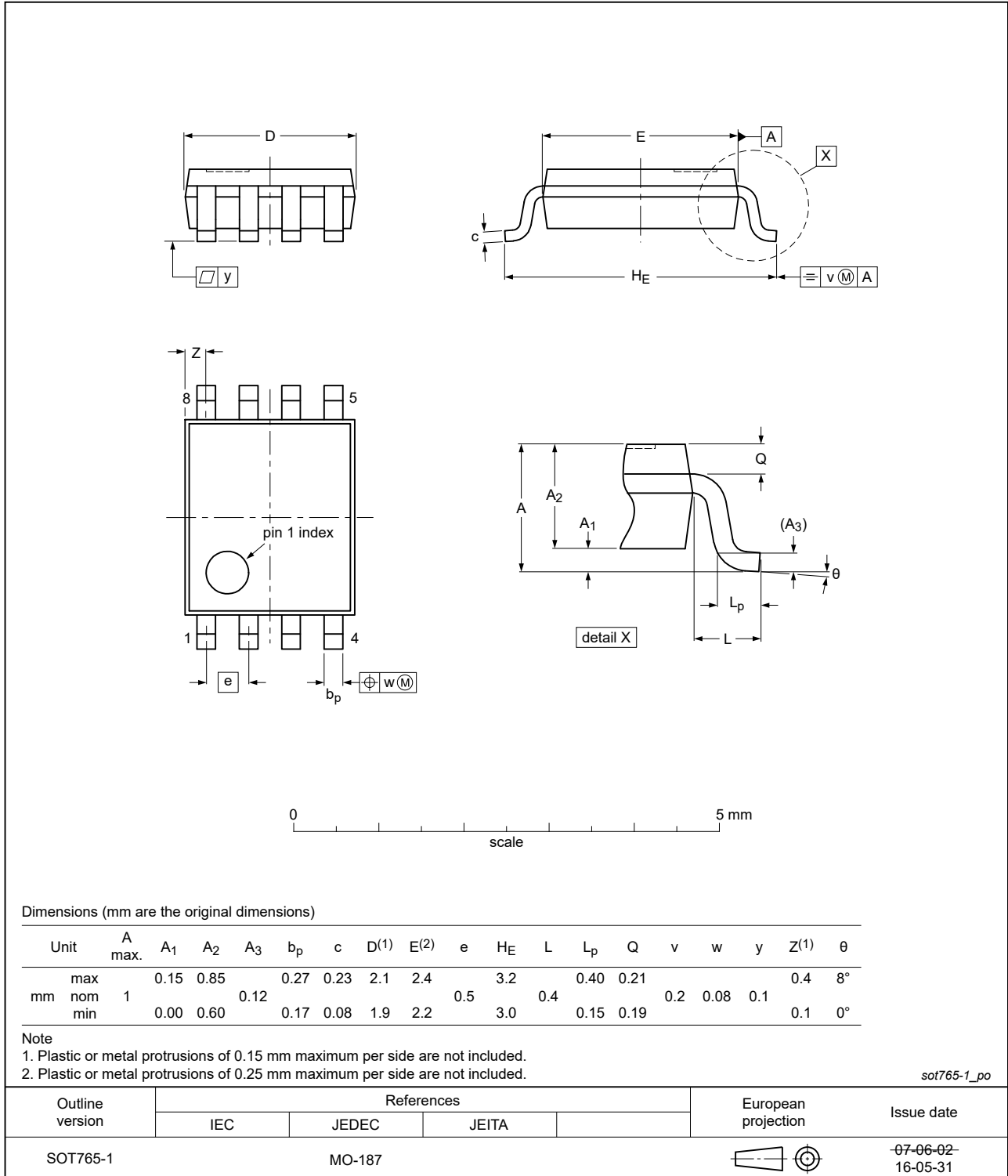

Fig. 8. Package outline SOT765-1 (VSSOP8)

15. Abbreviations

Table 14. Abbreviations

Acronym	Description
CDM	Charged Device Model
DUT	Device Under Test
ESD	ElectroStatic Discharge
HBM	Human Body Model
I ² C	Inter-Integrated Circuit
PCB	Printed Circuit Board
PRR	Pulse Rate Repetition

16. Revision history

Table 15. Revision history

Document ID	Release date	Data sheet status	Change notice	Supersedes
NXS0102_Q100 v.3	20231116	Product data sheet	-	NXS0102_Q100 v.2
Modifications:	<ul style="list-style-type: none"> Section 2: ESD specification updated according to the latest JEDEC standard. 			
NXS0102_Q100 v.2	20201113	Product data sheet	-	NXS0102_Q100 v.1
Modifications:	<ul style="list-style-type: none"> Table 10 and Table 11: Disable times updated. 			
NXS0102_Q100 v.1	20200923	Product data sheet	-	-

17. Legal information

Data sheet status

Document status [1][2]	Product status [3]	Definition
Objective [short] data sheet	Development	This document contains data from the objective specification for product development.
Preliminary [short] data sheet	Qualification	This document contains data from the preliminary specification.
Product [short] data sheet	Production	This document contains the product specification.

- [1] Please consult the most recently issued document before initiating or completing a design.
- [2] The term 'short data sheet' is explained in section "Definitions".
- [3] The product status of device(s) described in this document may have changed since this document was published and may differ in case of multiple devices. The latest product status information is available on the internet at <https://www.nexperia.com>.

Definitions

Draft — The document is a draft version only. The content is still under internal review and subject to formal approval, which may result in modifications or additions. Nexperia does not give any representations or warranties as to the accuracy or completeness of information included herein and shall have no liability for the consequences of use of such information.

Short data sheet — A short data sheet is an extract from a full data sheet with the same product type number(s) and title. A short data sheet is intended for quick reference only and should not be relied upon to contain detailed and full information. For detailed and full information see the relevant full data sheet, which is available on request via the local Nexperia sales office. In case of any inconsistency or conflict with the short data sheet, the full data sheet shall prevail.

Product specification — The information and data provided in a Product data sheet shall define the specification of the product as agreed between Nexperia and its customer, unless Nexperia and customer have explicitly agreed otherwise in writing. In no event however, shall an agreement be valid in which the Nexperia product is deemed to offer functions and qualities beyond those described in the Product data sheet.

Disclaimers

Limited warranty and liability — Information in this document is believed to be accurate and reliable. However, Nexperia does not give any representations or warranties, expressed or implied, as to the accuracy or completeness of such information and shall have no liability for the consequences of use of such information. Nexperia takes no responsibility for the content in this document if provided by an information source outside of Nexperia.

In no event shall Nexperia be liable for any indirect, incidental, punitive, special or consequential damages (including - without limitation - lost profits, lost savings, business interruption, costs related to the removal or replacement of any products or rework charges) whether or not such damages are based on tort (including negligence), warranty, breach of contract or any other legal theory.

Notwithstanding any damages that customer might incur for any reason whatsoever, Nexperia's aggregate and cumulative liability towards customer for the products described herein shall be limited in accordance with the Terms and conditions of commercial sale of Nexperia.

Right to make changes — Nexperia reserves the right to make changes to information published in this document, including without limitation specifications and product descriptions, at any time and without notice. This document supersedes and replaces all information supplied prior to the publication hereof.

Suitability for use in automotive applications — This Nexperia product has been qualified for use in automotive applications. Unless otherwise agreed in writing, the product is not designed, authorized or warranted to be suitable for use in life support, life-critical or safety-critical systems or

equipment, nor in applications where failure or malfunction of an Nexperia product can reasonably be expected to result in personal injury, death or severe property or environmental damage. Nexperia and its suppliers accept no liability for inclusion and/or use of Nexperia products in such equipment or applications and therefore such inclusion and/or use is at the customer's own risk.

Quick reference data — The Quick reference data is an extract of the product data given in the Limiting values and Characteristics sections of this document, and as such is not complete, exhaustive or legally binding.

Applications — Applications that are described herein for any of these products are for illustrative purposes only. Nexperia makes no representation or warranty that such applications will be suitable for the specified use without further testing or modification.

Customers are responsible for the design and operation of their applications and products using Nexperia products, and Nexperia accepts no liability for any assistance with applications or customer product design. It is customer's sole responsibility to determine whether the Nexperia product is suitable and fit for the customer's applications and products planned, as well as for the planned application and use of customer's third party customer(s). Customers should provide appropriate design and operating safeguards to minimize the risks associated with their applications and products.

Nexperia does not accept any liability related to any default, damage, costs or problem which is based on any weakness or default in the customer's applications or products, or the application or use by customer's third party customer(s). Customer is responsible for doing all necessary testing for the customer's applications and products using Nexperia products in order to avoid a default of the applications and the products or of the application or use by customer's third party customer(s). Nexperia does not accept any liability in this respect.

Limiting values — Stress above one or more limiting values (as defined in the Absolute Maximum Ratings System of IEC 60134) will cause permanent damage to the device. Limiting values are stress ratings only and (proper) operation of the device at these or any other conditions above those given in the Recommended operating conditions section (if present) or the Characteristics sections of this document is not warranted. Constant or repeated exposure to limiting values will permanently and irreversibly affect the quality and reliability of the device.

Terms and conditions of commercial sale — Nexperia products are sold subject to the general terms and conditions of commercial sale, as published at <http://www.nexperia.com/profile/terms>, unless otherwise agreed in a valid written individual agreement. In case an individual agreement is concluded only the terms and conditions of the respective agreement shall apply. Nexperia hereby expressly objects to applying the customer's general terms and conditions with regard to the purchase of Nexperia products by customer.

No offer to sell or license — Nothing in this document may be interpreted or construed as an offer to sell products that is open for acceptance or the grant, conveyance or implication of any license under any copyrights, patents or other industrial or intellectual property rights.

Export control — This document as well as the item(s) described herein may be subject to export control regulations. Export might require a prior authorization from competent authorities.

Translations — A non-English (translated) version of a document is for reference only. The English version shall prevail in case of any discrepancy between the translated and English versions.

Trademarks

Notice: All referenced brands, product names, service names and trademarks are the property of their respective owners.

Contents



1. General description	1
2. Features and benefits	1
3. Applications	1
4. Ordering information	2
5. Marking	2
6. Functional diagram	2
7. Pinning information	3
7.1. Pinning.....	3
7.2. Pin description.....	3
8. Functional description	3
9. Limiting values	4
10. Recommended operating conditions	5
11. Static characteristics	6
12. Dynamic characteristics	8
12.1. Waveforms and test circuit.....	11
13. Application information	14
13.1. Applications.....	14
13.2. Architecture.....	14
13.3. Input driver requirements.....	15
13.4. Output load considerations.....	15
13.5. Power up.....	15
13.6. Enable and disable.....	15
13.7. Pull-up or pull-down resistors on I/O lines.....	15
14. Package outline	16
15. Abbreviations	17
16. Revision history	17
17. Legal information	18

© Nexperia B.V. 2023. All rights reserved

For more information, please visit: <http://www.nexperia.com>
 For sales office addresses, please send an email to: salesaddresses@nexperia.com
 Date of release: 16 November 2023

Looking for pricing, stock, or lifecycle information?

Click below to explore more details on WIN SOURCE:

-  [View NXS0102DC-Q100H on WIN SOURCE](#)
-  [Nexperia USA Inc. Information](#)

Optimize Your Supply Chain with WIN SOURCE Solutions

-  Global Sourcing Solution
-  Obsolete Management
-  Cost Control Management
-  Shortage Management
-  Alternative Solution
-  Excess Inventory Management